



3 1761 06706032 7

UNIV. OF
TORONTO
LIBRARY

Digitized for Microsoft Corporation
by the Internet Archive in 2007.

From University of Toronto.

May be used for non-commercial, personal, research,
or educational purposes, or any fair use.

May not be indexed in a commercial service.

S. D
E 568.2

AMERICAN SUPPLEMENT
TO
ENCYCLOPÆDIA BRITANNICA.

(NINTH EDITION.)

A DICTIONARY

OF

ARTS, SCIENCES, AND GENERAL LITERATURE.

ILLUSTRATED.

VOLUME IV.

PHILADELPHIA AND NEW YORK:
HUBBARD BROTHERS, PUBLISHERS.

1889.

58
1713100

Entered, according to Act of Congress, in the year 1889, by
HUBBARD BROTHERS,
In the Office of the Librarian of Congress, at Washington.

ENTERED AT STATIONERS' HALL.

Vol. IV.

PREFACE TO VOLUME IV.

WITH the present volume the American Supplement to the Ninth Edition of the *Encyclopædia Britannica* is brought to a close soon after the completion of the original work. This Supplement was commenced in 1882 at the earnest request of a large number of the American subscribers to the *Britannica*. A dozen volumes, forming one-half of that great work, had then appeared and its circulation in the United States was steadily increasing. Prof. Robert Ellis Thompson, Ph. D., was selected as editor-in-chief of the new undertaking and under his supervision the plan was drafted and the greater part of the first two volumes was prepared for the press. The original publishers having then relinquished the work Prof. Thompson retired and was succeeded by Rev. Howard Crosby, D. D., LL. D. Prof. John P. Lamberton, as associate editor, has had constant and direct charge of the work throughout its progress.

It had been announced that the Supplement should be comprised in four volumes of size similar to those of the *Britannica*. The First volume corresponds to Volumes I.-IV. of that work; the Second to Volumes V.-VIII.; the Third to Volumes IX.-XVII., and this concluding volume to Volumes XVIII.-XXIV. It is a fact manifest to all who have made the comparison that since this American work has been under way the successive volumes of the *Britannica* have given evidence of increasing attention to American subjects. Especially the several States and cities of this country have been more carefully described by American writers. Some of these, therefore, whose names fall within the limits of this volume, it has been deemed unnecessary to treat again.

The *Encyclopædia Britannica* has also furnished in its Twenty-third Volume a compact article on the "United States," in which American authorities of the first rank have discussed our country's history, geography, climate, vegetation, mineral resources, population, commerce, etc. This elaborate treatise seemed at once to render it superfluous to discuss this subject again in a similar way. The reader should remember, however, that numerous topics, there briefly considered within the compass of one article, have been treated more fully under appropriate titles throughout the Supplement.

The greater fulness of the *Encyclopædia Britannica* on American topics in its later volumes has enabled the editors of the Supplement to traverse the corresponding ground more rapidly. They have still found abundant room for judicious enlargement and addition to the original work. American biography, the careers and works of living persons of note at home and abroad, the political, legal, religious and social institutions of our country, its natural history and resources, are here exhibited at such length as their interest to Americans seemed to demand.

The important subjects relating to the Bible, which have been treated in the *Britannica* in an extremely rationalistic spirit (the later volumes in this regard exceeding the earlier), have been discussed in this Supplement in a reverent manner by American scholars of acknowledged ability. The views here presented, so far as they controvert the assertions of the English and German writers in the *Britannica*, will be found to be based on an equally thorough knowledge of the original languages and to show a more thorough sifting of evidence.

In concluding their labors in connection with this work the publishers and editors render their hearty thanks to the contributors who have diligently assisted them in their endeavor to amend, enlarge, perfect and adapt to American ideas the marvellous treasury of information to be found in the *Encyclopædia Britannica*. They trust that the American public which has shown a kind appreciation of the former volumes will receive this concluding volume with the same generous favor

LIST OF CONTRIBUTORS.

VOLUME IV.

This list embraces the names of those contributors whose names are signed (by their initials) to articles in the present volume.

Where two or more contributors have the same initials, a distinction has been made in printing them, which will enable the reader to assign to each his own work.

The writers whose names are marked with an asterisk (*) have exercised more or less editorial supervision in their respective departments.

HOWARD CROSBY, D. D., LL. D., *Editor-in-Chief.*

Prof. JOHN P. LAMBERTON, A. M., *Associate Editor.*

- | | |
|---|--|
| Prof. CLEVELAND ABBÉ, U. S. Signal Service Bureau, Washington, D. C.
Signal Service. | Col. JAMES A. COLVIN, New York.
Paper. |
| H. G. ADAM, Editor <i>Oil, Drug and Paint Review</i> , New York.
Oils, Petroleum, Pipe Lines, | ELLIOTT COUES, M.D., National Museum, Washington, D.C.
Night Hawk, Partridge. |
| WILLIAM B. ATKINSON, M. D., Secretary American Medical Association, Philadelphia.
Obstetrics. | Rev. JOSEPH CUMMINGS, D. D., LL. D., Evanston, Ill.
Northwestern University. |
| Surg. PRESTON H. BAILHACHE, U. S. Marine Hospital Service.
Sanitary Science, Sewerage, Vaccination, | MADISON DAVIS, Post-Office Department, Washington, D. C.
Postal Service. |
| Hon. KEMP P. BATTLE, LL. D., Chapel Hill, N. C.
North Carolina, North Carolina University. | Rev. D. D. DEMAREST, D. D., New Brunswick, N. J.
Reformed Church in America. |
| * Prof. WILLIS J. BEECHER, D. D., Auburn Theological Seminary, N. Y.
Pentateuch, Philistines, Prophets, Psalms, Ruth, Book of Samaria, | Hon. JOHN M. DOANE, State Librarian, Columbus, Ohio. |
| Hon. CHARLES H. BELL, Exeter, N. H.
New Hampshire. | Rev. T. S. DOOLITTLE, D. D., New Brunswick, N. J.
Rutgers College. |
| REV. FREDERIC M. BIRD, South Bethlehem, Pa.
Sanitary Commission, Strikes, Theological Seminaries, and other biographical articles. | Pres. JULIUS H. DREHER, Ph. D., Salem, Va.
Roanoke College. |
| JOHN BIRKINBINE, M. E., Philadelphia.
Rolling Mills. | Rev. J. H. DUBES, D. D., Lancaster, Pa.
Reformed Church in the United States. |
| Col. R. BRINKERHOFF, Ohio State Board of Charities, Mansfield, Ohio.
Prison Discipline, Reformatories. | WILLIAM H. EGGLE, M. D., State Librarian, Harrisburg, Pa.
Pennsylvania. |
| R. W. D. BRYAN, Esq., Albuquerque, N. M.
New Mexico. | J. H. ESTILL, Editor <i>Savannah News</i> , Savannah. |
| Rev. H. C. CAMERON, D. D., Princeton, N. J.
College of New Jersey. | WALTER M. FERRISS, Bay Ridge, L. I.
Patents, Polygamy, Riots, State Militia. |
| Rev. ELMER H. CAPEN, D. D., College Hill, Mass.
Tufts College, Universallum. | Prof. G. M. FORBES, Rochester, N. Y.
Rochester, University of. |
| Rev. TALBOT W. CHAMBERS, D. D., New York.
Resurrection. | MASON F. GALLAGHER, U. S. Pension Bureau, Washington, D. C.
Pension System. |
| Hon. THOS. V. COOPER, Chairman of Pennsylvania Republican State Committee, Media, Pa.
Republican Party. | Rev. HERVEY D. GANSE, D. D., Chicago.
Sabbath. |
| | Rev. T. A. K. GESSLER, D. D., New York.
Rationalism, Socialism. |
| | * CHARLES W. GREENE, M. D., Merchantville, N. J.
Neat Cattle, New Jersey, and articles in Natural History, Prairie, Snakes. |
| | Prof. SAMUEL HART, Hartford, Conn.
Trinity College. |
| | S. S. HERRICK, M. D., Secretary Board of Health, New Orleans, La.
Small-Pox. |

FREDERICK HESS, Fort Dodge, Iowa.

Notenaka

Major-General OLIVER O. HOWARD, U. S. A.

Revolutionary War, War of 1812

* JAMES HUNTER, Lynchburg, Va.

Pentecostal Campaign, McClellan's, Stuart, Gen. J. E. B.,
Savanna, Battle of, Thomas, Gen. George H.,
Shenandoah Valley, Verrazano, Greenwich,
South Mountain and Antietam, Vicksburg, Siege of,
Stone River, Battle of.

Prof. THOMAS HUNTER, New York.

Normal Schools

HOWARD M. JENKINS, Jenkintown, Pa.

Quakers

Mrs. C. B. KILGORE, Philadelphia.

Women, Law Relating to.

* Prof. JOHN P. LAMBERTON, Philadelphia.

Newman, John Henry, Sloux,
Nativism, American, Stanley, Henry Morton,
Farnell, Charles Stewart, Taine, Hippolyte A.,
Pamphletting, Tammany Society,
Phillips, Wendell, Thurman, Allen G.,
Pennsylvania, University of, Time, Standard,
Rennan, Ernest, United Presbyterian Church.

Rev. B. B. LEACOCK, D. D., Baltimore.

Reformed Episcopal Church.

Rev. H. M. MCCracken, D. D., New York.

University of the City of New York.

WILLIAM F. MACLENNAN, U. S. Treasury Department,
Washington, D. C.

Treasury of the United States.

FREDERIC G. MATHER, Albany, N. Y.

New York, Reciprocity,
New York City, Sports, Athletic,
Niagara, Stoves,
Ontario, Lake, Street Railroads,
Opium, Taxidermy,
Political Conventions, Telegraph,
Public Lands, Thanksgiving,
Receivers, Whig Party.

JOHN P. MEANY, Editor *Poor's Manual of Railroads*.

Railroads.

THOMAS MEEHAN, Philadelphia.

Manusculas.

JOSEPH C. MOORE, San Francisco.

Nevada,

Oregon.

* CHARLES MORRIS, Academy of Natural Sciences, Philadelphia.

Ocean Life, Sheep,
Oleostearine, Silk,
Opater, Silver,
Parks, Societies, Mutual Aid,
Belmud, Grant's Siege of, Soils,
Ruskin, John, Spencer, Herbert,
Salmon, Stones, Building and Precious,
Salt, Sugar,
Sequoia, Tornado,
Sewing-Machines, Viticulture,
Shael, Volapuk.

Rev. THOMAS B. NEELY, Ph. D., D. D., Philadelphia.

Parliamentary Practice.

* Lieut. LEWIS NIXON, Assistant Naval Constructor, U. S. N.

Ordnance,
Shipbuilding,

Steel.

HAMILTON PELTZ, *The Press*, Philadelphia.

Typography.

SAMUEL C. PERKINS, Esq., Philadelphia.

Property

THOMAS BEATH, Esq., Philadelphia.

Negligence, Receipt,
Neutrality, Urury,
Partnership, Will,
and other legal articles.

* Rev. MATTHEW B. RIDDLE, D. D., Western Theological
Seminary, Allegheny, Pa.

New Testament, Peter,
Pastoral Epistles, Revelation, Book of,
Paul, Romans, Epistle to.

Prof. C. V. RILEY, Smithsonian Institution, Washington,
D. C.

Phylloxera.

Rev. E. G. ROBINSON, D. D., President of Brown University,
Providence, R. I.

Rhode Island, Sears, Barnas.

HENRY R. ROSE, College Hill, Mass.

Sports, Athletic.

Rev. JOHN RUSSELL, Albion, Mich.

Prohibition Party.

Rev. L. CLARK SEELYE, D. D., Northampton, Mass.

Smith College.

JOHN GILMARY SHEA, LL. D., Elizabeth, N. J.

Roman Catholic Church.

Prof. E. G. SHULER, New York.

Seyfarth, Gustav.

Rev. LUCIUS E. SMITH, D. D., Editor of *The Watchman*,
Boston, Mass.

Religious Liberty, Temperance Reform.

Rev. WILLIAM M. TAYLOR, D. D., Poughkeepsie, N. Y.

Vassar College.

Prof. JAMES R. TRUAX, Schenectady, N. Y.

Union College.

Prof. ROBERT ELLIS THOMPSON, Ph. D., D. D., University
of Pennsylvania.

Political Economy, Taxation,
Tariff.

COLIN K. URQUHART, Lockwood Press, New York.

Pen, Pencil.

NOBMAN WALKER, *The New Orleans Times-Democrat*,
New Orleans, La.

New Orleans.

CHARLES E. WASHBURN, M. D.

Tennyson, Lord Alfred, Swinburne, Algernon Charles.

* FRANK WEITENKAMPF ("Frank Linatow White"), Astor
Library, New York.

Opera, Piano,
Organ, Rogers, Randolph,
Painting, Sculpture in America,
and biographical sketches of artists.

EDGAR A. WERNER, Esq., Editor *Civil List*, Albany, N. Y.

Savings Banks, Trust Companies,
Safe Deposit Companies.

J. WILLIAM WHITE, M. D., University of Pennsylvania.

Physical Education, Surgery, American.

* Hon. A. J. WILLARD, late Chief-Justice of South Carolina,
Washington, D. C.

Nullification, Sedition,
Petition, Right of, Slavery,
Reconstruction, States' Rights,
Representation, Territory,
Repopulation, Treason,
Revolution, American, Treaty,
Search, Right of, Veto,
Secession, Walte, Morrison B.

Col. GEORGE W. WILLIAMS, Worcester, Mass.

Negro in America.

J. WYLLIE WILLIAMS, Philadelphia.

Virchow, Rudolf, Youmans, Edward L.,
and other biographical sketches.

Rev. DAVID B. WILLSON, D. D., Allegheny, Pa.

Reformed Presbyterian Church.

CHARLES F. WINGATE, Sanitary Engineer, New York.

Sewerage.

WILLIAM C. WINLOCK, U. S. Naval Observatory, Wash-
ington, D. C.

Observatories, Telescopes.

HORATIO C. WOOD, M. D., University of Pennsylvania.

Poisons.

AMERICAN SUPPLEMENT TO ENCYCLOPÆDIA BRITANNICA.

NEAGLE—NEAT CATTLE.

NEAGLE, JOHN (1799–1865), painter, was born at Boston, Nov. 4, 1799. He was apprenticed to a coach-painter in Philadelphia, and about 1818 began to paint landscapes. In 1826 he painted Patrick Lyon the Blacksmith, and afterwards Gilbert Stuart, both of which are now in the Boston Athenæum. He married the daughter of the artist Thomas Sully, who gave him much encouragement and help. He lived for a time at New Orleans, but spent most of his life in Philadelphia. Among his notable portraits are Washington, Henry Clay, Henry C. Carey. He died at Philadelphia in 1865.

NEAL, DAVID, an American-German artist, was born at Lowell, Mass., in 1837. He went to Munich in 1861, and while studying there married the daughter of Chevalier Aimmuller. In 1869 he entered the studio of Piloty, and afterwards devoted himself entirely to figure-painting. Among his earlier works were *The Chapel of the Kings*, Westminster Abbey, and *The Interior of St. Mark's*, Venice. In 1876 his noted painting, *The First Meeting of Queen Mary Stuart and Rizzio*, obtained the grand medal of the Bavarian Academy. Among his other pictures are *The Return from the Chase*, James Watt, and several portraits.

NEAL, JOHN (1793–1876), author, was born at Portland, Maine, Aug. 25, 1793. After a varied experience of business life he studied law, but decided to obtain his living by his pen. In 1817 he published his first novel, *Keep Cool*, and about the same time was disowned by the Society of Friends, in which he had been brought up. He published a volume of poems, a tragedy, and wrote the *History of the American Revolution*, to which Paul Allen's name was prefixed. He prepared an index to the 50 volumes of *Niles' Register*, and wrote *Seventy-Six* and other novels. Going to England in 1824, he wrote for *Blackwood's Magazine* and other periodicals, and lived for a time with Bentham. Returning to America in 1827, he settled at Portland, and wrote diligently for the newspapers, practised law, and taught sparring and fencing. He gave up his profession in 1850, but continued to write. He died at Portland, Me., June 20, 1876. Among his works are *Brother Jonathan* (1825); *Rachel Dyer* (1828); *Bentham's Morals and Legislation* (1830); *Down-Easters* (1833); *True Womanhood* (1859), and finally his *Wandering Recollections of a Somewhat Busy Life* (1870).

NEAL, JOSEPH CLAY (1807–1847), humorist, was born at Greenland, N. H., Feb. 3, 1807. His father

had been principal of a school in Philadelphia, and after his death the family returned to that city. Joseph became connected with newspapers, and in 1831 was editor of the *Pennsylvanian*, which he conducted for several years, until his health failed. He went abroad in 1841, and in 1844 established *Neal's Saturday Gazette*. He died at Philadelphia, July 18, 1847. To his papers he had contributed sketches which were collected under the title, *Charcoal Sketches, or Scenes in a Metropolis* (1837). These were republished in London by Dickens. Neal also wrote *Peter Ploddy* (1844), and a new series of *Charcoal Sketches*.

NEAT CATTLE. What are called the "native cattle" of the United States are of no definite breed or strain, and are descended from animals coming from various parts of Europe. During the colonial period settlers coming from different parts of England naturally took with them the live-stock of their own districts. The British Islands, even from early times, had cattle of various types, although little pains were taken to keep the breeds distinct, or to rear stock having any special points of excellence. As a consequence the importations to this country were of varied character, and in many parts the stock assumed a mongrel type. The Dutch carried to New York their own excellent races of cattle; the French took theirs to Canada and Louisiana; cattle of Spanish breeds were imported to Texas, California, and Florida. There were also importations made later of large, yellow cattle from Denmark. Such and so various were the ancestors of the horned cattle of North America.

But the methods and conditions of early American agriculture had their effects on the live-stock kept in the colonies. In New England the cattle were remarkable for hardiness and for activity under the yoke, and not a few cows possessed excellent milking qualities. In this part of the country oxen are still largely employed for labor on farms. Throughout the lumbering districts, both in the North-west and in the South, oxen are much employed in drawing logs from the forests, being serviceable in rough and roadless places where the less patient horse cannot be employed to advantage. For like reasons oxen are also esteemed for work in stone-quarries, and generally in mountainous districts. In the Southern States many of the poorer class of farmers employ steers, or even cows, for draught purposes, often fastening a single animal by a rude harness to the shafts of a little cart. Elsewhere oxen are com-

monly worked in pairs, being yoked together by the neck. The head-yoke, so commonly used on the continent of Europe, is sometimes seen in this country, and its general use has found some earnest advocates among intelligent agricultural writers.

Hardly anywhere in the United States have there been stocks of cattle produced worthy of distinction as new breeds. An exception might be made in favor of the Texans and of a race of small cattle reared in the swampy regions of Florida. These diminutive Florida animals have latterly acquired a good reputation as generous producers of milk, and in the Southern States there has been awakened a considerable demand for them, not as true dairy animals, but rather as suppliers of milk for family use in villages and suburban places, much as Kerry cows are kept in the British Islands. It is not a little remarkable that in some marshy districts of the Gulf States the cattle have adopted some of the habits of the oriental buffalo, often submerging themselves in water to escape the heat of the sun and the attacks of insects, and plunging the head under water while browsing on aquatic and floating plants. In eating this kind of food the cattle devour also great numbers of insect larvae and of other small water-animals of low type.

What are called Texan and Cherokee cattle are descendants of early Spanish importations. They are extensively bred in the South-west, where they live in a more than half wild state, cared for by mounted herders and cowboys, and knowing nothing of shelter nor, as a rule, of artificial feeding. A very large proportion of the stock on Western cattle-ranches is of this Texan race, wholly or in part. The reasons why they are still reared are these: they are very hardy, they are very cheap, and they already have the field. Intrinsically, the Texan steer is of little worth. The cows have very little of the milking quality. The form is lean and lank, the bones prominent, the horns of enormous size, the beef is of inferior quality, the fat very scanty. Yet many thousands of these cattle are marketed all over the country. The best are sometimes selected for corn-feeding, and are then partially fattened before being taken to the shambles. Many thousands of these bulls and cows come to us from Mexico, being driven across the line as "breeding animals," and thus escaping duty at the custom-house. The chief value of the Texan cows is as the mothers of grade Short-horn or Hereford heeves. The first cross with a blooded bull will produce steers and cows which, when three years old, will be worth double what a Texan animal of the same age is worth, besides being much more tractable in disposition. Half-blooded Texans, when well cared for, are often handsome animals.

The business of cattle-ranching has become a great feature of American enterprise. Vast fortunes have been made in it with small original capital, and the occupation has in itself many points of attraction for young men of adventurous and enterprising spirit. The life of ranchmen and cowboys is marked, indeed, with much of hardship and excitement, and some of its heroes have already found their way into dime novel literature and the weekly story-papers. But as hitherto conducted, there is as much or more to repel as to attract a sober-minded business man. The risk of losing stock from winter storms and scanty pasture is very great. Wealthy and unscrupulous ranchmen well understand the art of ruining the prospects of young and inexperienced aspirants. More than all, the field, or the best of it, is already well occupied, and the business is taking on new features. Many capitalists now have their own cattle-ranges instead of feeding their stock on the public lands. The fencing-in of such ranges interferes with the old practice of shifting the feeding ground with the change of seasons; and many breeders who have irrigable or arable lands find it to their advantage to grow winter forage for their stock.

The personnel of the cattle-ranges presents many

points of interest. Not a few cattle-men are college-bred gentlemen, with a taste for literature and society, but naturally, many frontiersmen of almost savage habits, and men from the Eastern States and from Europe with no character and doubtful record, have drifted into the business, the latter chiefly taking subordinate places.

The cattle-ranching business in the United States is carried on in all the unsettled districts between the Mississippi River and the Pacific, from the "Bad Lands" of the Upper Missouri southward to the Gulf of Mexico. Indeed, the "Bad Lands" have some good points for the cattle-men, for in their "draws," or ravines, the stock are sheltered from the winter storms, and in many spots good pasturage is to be found. Even the elevated mountain valleys and the desolate wastes of Arizona and Nevada are, to a great extent, covered with cattle-ranges. Such an unpromising native plant as the "white sage" (*Eurotia lanata*, called "winter-fat" in some places) is highly esteemed for its property of keeping the cattle fat in winter.

Among the improved breeds seen in the United States, the first place in point of popularity and in the money value of stock must undoubtedly be given to the Short-horns. The eastern and north-eastern counties of England were the original home of this race, which appears to have an alliance with the Dutch and Holstein breeds. As early as 1785 cattle of this stock were taken to what is now West Virginia, a State which to this day breeds many excellent beef-cattle, and others about the same time were sent into the State of New York. The first Short-horns were taken to Kentucky in 1800. Col. Lewis Sanders, of Kentucky, in 1817 made further importations. Col. John Hare Powl, of Philadelphia, was another early Short-horn importer of note. From year to year many high-priced animals of the best Short-horn families have been introduced into this country, until now the best American Short-horn stock is fully equal to any in the world, and some of our best animals have been sent to Great Britain for breeding purposes. The Short-horns are hardy in habit, of good constitution, and are of high excellence as beef-producers. The cows often prove good milkers. But this race is chiefly valued in this country for grading up unimproved herds of native stock. For this purpose no bulls but those of pure Short-horn race should be employed. The half-breed grade Short-horns are often animals of great beauty and excellence, but the males should not be used for breeding purposes. Short-horns make strong and willing oxen, but are considered too slow for general farm-use. For this purpose the more active *North Devons* are much preferred. This race of beautiful and gentle animals is of English origin. Many of them have been from time to time imported into this country, and there are many districts to which they are well adapted. The cows are fair milkers, the milk is rich, and the beef is excellent, though the steers are not so early fit for the butcher's use as are those of the Short-horn blood. The *Hereford* breed has many excellent qualities. It is a good beef-producing family, but the cows are seldom of much use in the dairy, and many breeders consider that the steers are less hardy and require more skill than Short-horns need in order to be bred to a profit. The *Ayrshires* are a handsome Scottish race with strong Short-horn alliances. They are splendid and copious milkers, and are justly valued by dairymen. Their milk is less rich in butter than that of the Channel Island cows, but they are more profitable when the milk is sold in the cities, and their milk is inferior to none for use in the cheese-factory. There are "butter families" and "cheese families" among cattle of this breed. The *Jersey* and *Guernsey* breeds are the two principal stocks of Channel Island cattle, for the true *Alderneys* are scarcely known to the general breeder. These relatively small and very beautiful animals are greatly prized for the richness of their

milk and the excellence of their butter. They are often kept for family use, and many American butter-producers keep them in considerable herds. Their peculiar excellence is often transmitted to their grade offspring, which frequently excel their mothers in the quantity of their milk. The bulls of this race are often singularly fierce and treacherous. For the shambles, the Channel Island cattle have little to recommend them. Many *Dutch*, *North Holland*, and *Holstein* cattle are now bred in this country. Practically, they may be considered as all of one breed. They produce enormous quantities of milk and are every year increasing in favor with dairymen. They are of large size, and when past the age of service make good beef. For producing butchers' steers, it is believed that this breed and its grades will not rank far below the Short-horns. The *hornless Scotch* breeds (the Aberdeen, polled Angus, and Galloway) are very thrifty and hardy animals, producing a good flow of rich milk. They afford excellent beef steers, and are of late attracting much attention in this country. The nations of Continental Europe have a great many well-marked breeds of cattle. Several of these are worthy of trial in this country. A few breeders have turned their attention to Swiss cows, of which there are several pretty distinct stocks. Some strains of Swiss cows have proved extremely profitable as milk-producers, while for hardness and activity they are not surpassed. These latter qualities ought to fit them well for ranch life. On the plains an active, independent animal that can shift for itself, and does not fear wolves or wild dogs, and has the courage to graze far away from water-holes, is highly valued, and is set down as "a good rustler," the highest title of commendation that a beast or a man can receive on the plains.

The subject of *transportation* of cattle has received great attention in this country, and the trunk-lines of railway have invested large sums of money in cattle-cars and the other appliances needed in the business. Near most of the large cities of the country extensive *stock-yards* have been established for the reception and marketing of cattle. Much capital has been employed in the shipment of live-stock to European markets, but the recent invention of cheap systems of refrigeration, by means of which dressed beef can be shipped in perfect condition from New Zealand or Australia to London, has interfered with American shipments of living cattle and made capitalists very cautious in their ventures in such enterprises.

For an account of the cattle-ranch business in its palmiest days see Gen. J. S. Brisbin's *The Beef Bonanza* (1880). The U. S. Census Report of Mr. Clarence Gordon on *Meat Production* (1880, published in 1883) is a very elaborate and careful one, but its statistics have already gone out of date, so rapidly has the business been developed since that report was made. (See MEATS.) (C. W. G.)

NEBRASKA. Since 1883 the following changes have been made in the counties of this State. Sioux county has been divided into three, the most western retaining the original name; the middle is Dawes county, with county-seat at Chadron; the eastern is Sheridan, with county-seat at Rushville. Keya Paha county has been formed from that part of Brown north of the Niobrara river, and has Springview as its county-seat. From the part formerly unorganized have been formed the counties of Blaine, with county-seat at Brewster, and Logan, with county-seat at Gandy.



There still remain 112 townships unorganized.

The population of the State is estimated, in 1888, at 750,000. At the State election in November, 1886, the total vote was 138,239. There are many unnatur-

alized foreigners domiciled here. The total area is about 52,000,000 acres. Much still belongs to the public domain, and is subject to entry under the U. S. land laws at the government land offices at Beatrice, Lincoln, Niobrara, Grand Island, North Platte, and Neligh. Investigation is being carried on in regard to entries in the western half of the State, and final action on these is deferred until their character is proved.

Of the 12,370,497 acres of land granted by Congress to the Union Pacific Railroad, and of the 2,315,864 acres to the Burlington and Missouri Railroad, to which the State also gave an additional 50,000 acres, much remains as yet unsold within the State, and can be had at reasonable prices and on easy terms; while the State still owns 2,786,527 acres, subject to sale at not less than \$7 per acre, or to lease for terms of 20 years, at an annual rental of 6 per cent, on an average valuation of \$2.50 per acre, with the privilege to purchase at any time for not less than \$7 per acre, and subject to forfeiture of rents paid and improvements made on the land if the terms of the lease are not strictly complied with.

The total valuation of taxable property within the State as assessed for 1886-87 was \$133,418,699, of which \$18,534,789 was represented by 2,765 miles of railway, and the remainder by real estate and personal property in the hands of private owners. But for such property there is no standard of value fixed by law, and the biennial assessments for tax levies are no index whatever to its market value, which depends wholly upon the caprice or necessity of the private owner, the supply of and demand for money, and is purely a matter of speculation.

Within a few years Omaha was transformed from a provincial town of muddy streets and rickety frame buildings into a beautiful city of magnificent dimensions, with miles upon miles of excellent pavement lined on each side with grand structures of brick, iron, and stone in the latest styles of noble architecture, heated by steam and lighted by electricity and provided with all modern improvements.

Nebraska has been struggling with the problem of taxation and of just equalization of land values. As yet taxes on real estate are much lighter there than in other States; her tax laws do not essentially differ from those of other Western States. The Legislature in 1887 commenced the work of revenue and land tenure reform in good earnest. A law was passed looking toward the abolition of alien ownership of land, the limitation of private land ownership in general to actual use and occupation, and the raising of revenue by taxation of products rather than of the means of production.

The act of May 30, 1854, creating the Territory of Nebraska, abrogated the Missouri Compromise, making the line of 36° 30' N. lat. a boundary to the extension of African slavery on this continent, and while it was declared to be the true intent and meaning of that act "not to legislate slavery into any Territory or State, nor to exclude it therefrom, but to leave the people thereof perfectly free to form and regulate their domestic institutions in their own way," etc., the real design of the promoters of that act was to open all the western country to the introduction of negro slavery wherever profitable. The long and bloody struggle that ensued ought to be a warning to both sides in the present conflict between capital and labor over the means of existence. Otherwise Nebraska has profited by the experience of her elder sisters, and has shown greater wisdom in the prudent management of her munificent endowments by the national government for educational purposes and public buildings.

The new State capitol at Lincoln, in process of construction, is to be completed in December, 1889, at a cost of \$439,187, according to the contract made in 1883, and when completed it will be of more imposing appearance and better adapted to its uses than other more costly buildings of the kind.

The new *Insane Asylum*, at Norfolk, is a substantial brick building with a stone basement, 244 feet by 75. It has four stories, the top of its main tower being 120 feet high. It was erected at a total cost of \$65,772, but has not been opened as yet for the reception of patients.

The *State Reform School* for juvenile offenders, located on a farm of 320 acres, near the city of Kearney, in Buffalo county, has been enlarged by the addition of two new family buildings and a workshop at a cost of \$25,600. Instruction and labor under thorough discipline, which is that of the family, the school, the workshop, and the farm, rather than that of the prison, are the means employed for the reformation of those committed to its charge. Lately, instruction in military tactics has been introduced there with good results. The library contains 520 volumes of well-selected books. Besides an abundance of wholesome food for the inmates, the farm last year yielded a surplus for sale amounting to \$800. The total number of youths committed to the care of this institution from its opening in 1883 until 1886 was 208, of which 166 were boys and 42 girls.

The *State Penitentiary*, at Nobesville, is a solid stone structure, containing three tiers of eighty cells each, to which another tier of cells is to be added. Wooden buildings in the prison yard are used for workshops. The prison library contains over 3000 volumes of choice literature. The total number of prisoners received since its foundation in 1869 is 1146, of which 328 remained in prison at the beginning of the present year. Of these 307 were white, 16 colored, and 5 Indians.

The *Nebraska Institute for the Blind* is located at Nebraska City, and has now entered upon the twelfth year of its existence. During that time 73 blind children have received instruction, and 9 have completed the prescribed course. The enrolment in 1886 was 38.

A *Home for the Friendless* has been erected at Lincoln, costing \$10,000, but is not yet open.

An *Asylum for Feeble-Minded Children and Adults*, costing \$15,444, has been established near the city of Beatrice. It is a substantial two-story brick building with stone basement, 141 feet long by 91 feet wide, provided with all modern improvements, and will afford comfortable quarters for all of the 614 idiotic and imbecile persons thus far discovered within the State.

The *Institute for the Deaf and Dumb*, at Omaha, has been much improved. There are now 144 pupils at this institution, of which 83 are males and 61 females, from 7 to 22 years old.

The *Hospital for the Insane*, at Lincoln, has been renovated and enlarged, and the grounds around the buildings have been greatly beautified by the laying out of drives, walks, grass-plats, and flower-beds, and many other improvements have been made about the premises; 747 patients have been received there for treatment in 1886-87, and the present enrolment is 374, of which 227 are males and 147 females. A carefully selected library of some 450 volumes has been added to the hospital.

The *State University and Agricultural College*, at Lincoln, has been repaired and remodelled, and a new building of fine proportions has been erected at a cost of \$23,700 for the use of the industrial and scientific department. A complete equipment made to order in Europe has been procured for the Chemical Laboratory; 3000 volumes have been added to the general library; 325 to the Botanical Library; 1497 specimens to the Botanical Cabinet; 15,000 specimens to the Herbarium; and 1792 specimens to the Geological Cabinet. The fine arts school acquired a valuable collection of casts from the French exhibit at New Orleans. The total number of students is now 313, of which 31 attend the college of medicine, 135 the industrial and scientific school, 126 the Latin school, and 71 the school of fine arts.

The *State Normal School*, at Peru, has been enlarged by the addition of a substantial brick structure 94 by

56 feet, two stories high and a basement, and many other improvements have been made at a total cost of \$20,000. Its library now contains about 5000 volumes. Attendance increased from 274 students in 1881 to 478 in 1887.

The appropriations for the current expenses of these State institutions for the years 1887 and 1888 amount in the aggregate to \$2,722,897.

The Common Schools of the State are most liberally provided for. The total expenditures for these schools during the years 1885-86, including \$244,081 on hand at the close of 1886, amounted to \$6,357,624. The permanent common school fund, arising from a munificent endowment in lands yielding a large sum annually, had increased to \$4,904,119 at the close of the year 1886, and it is estimated that this fund will reach full \$20,000,000 when the lands are all sold. In the 4400 school districts of the State there are now enumerated 252,006 school children of both sexes, of which 180,059 are enrolled with an average attendance of 107,945 in 4369 school-houses, valued at \$3,821,317, and provided with \$122,675.33 worth of books and apparatus. During 1886 teachers' institutes were held in 66 counties, lasting on an average 11 days each, with an average daily attendance of 4225 teachers out of 5359 enrolments, at a total cost of \$11,947. The average monthly wages of male teachers is \$42.68, and of female teachers, \$34.70.

In 1843 districts lists of uniform text-books have been adopted which the pupils are required to purchase; 422 districts select their own text-books and furnish them free of cost to the children, while the remainder of the districts have as yet adopted no settled policy in this respect. The uniform experience in the districts which have adopted the free text-book system is, that it saves time and money, that school attendance is increased, that children of poor parents are kept at school longer, that the cost of books has been reduced one-third, and that of other supplies about one-half, and that in no case have contagious diseases been communicated thereby. "Arbor Day" (April 22) is generally observed in all the schools as a holiday, devoted to the planting of trees, with appropriate ceremonies and discourses on memorable persons and events. Besides these public schools there are a number of colleges and private schools devoted to higher education. Prominent among these are Creighton College, a Catholic institution at Omaha, for young men alone, and Brownell Hall, an Episcopal Seminary for young ladies alone, also at Omaha; the Methodist Episcopal College of Nebraska at York; the Nebraska Central College, another Methodist institution, at Central City; Gates College, established by the Columbus Association of Congregational Ministers and Churches, at Neligh; and Doano College at the beautiful town of Crete, another Congregational institution and the oldest of the kind in the State, having been founded in 1872; Merrill Hall was added in 1879, Boswell Observatory in 1883, and Ladies' Hall in 1884. These are for both sexes. Omaha and other towns of the State are also justly proud of their Public High Schools, where the eight years' course of common school studies is supplemented by a four years' course of instruction in the higher branches.

The growth of churches of all denominations has been co-equal with the general progress of the State, and many fine edifices have been and are being erected in every city and throughout the country generally.

Railroads.—The total number of miles operated within the State by the various railroad companies in 1886 was 3051 miles, of which 1633 miles were composed of steel rails and the rest of iron rails. The capital stock of these roads is estimated by the Railway Commissioners at \$66,292,832, or an average of \$21,722 per mile, and their aggregate debt at \$83,122,813. Their gross earnings for the year ending June 30, 1886, were \$15,720,747.95, an increase of \$1,571,429.25 over the previous year. The total amount of taxes paid by

the various lines was \$647,210, being over 8 per cent. on their net earnings within the State.

The total number of persons directly employed in the operation of the roads was 12,190, who earned \$6,745,454, or an average of \$582 each, during the year.

The main trunk lines traversing the length and breadth of the State are competing with each other for new territory, and pushing out branch lines in every direction, so that the total mileage of railroads will soon be greatly augmented.

The building of railroads and telegraph lines, the turning of the sod, and the planting of groves has had a marked ameliorating influence on the climate of the State, increasing the moisture and modifying the conditions of the atmosphere.

The observing traveller on a second summer's journey through the State, after an interval of a few years, cannot fail to be impressed with the changed appearance of the country, and notice that verdure and showers of blessings follow the star of empire in its westward course.

There is a marked difference in the water of streams heading on the Divide running east and west through the State about 25 miles south of its northern boundary. The waters flowing southward into the Platte River are all strongly alkaline, while those flowing northward into the Niobrara River are all soft-water streams from springs gushing out of the hillsides all along the northern side of the Divide, until the gypsum country of the Black Hills is reached. This northern part of the State gradually rises from an altitude of 1000 feet at the Missouri River to 3500 feet at the western boundary, giving a very good mean altitude for health and freedom from miasmatic troubles.

Agriculture and stock-raising are the chief industries of the State. The staple products of the farm are corn, wheat, oats, rye, barley, flax, broom-corn, sorghum, millet, all the common garden vegetables and the products of the dairy, the total value of which, produced during 1887, is estimated at \$60,000,000. The abundance of summer and winter pasture and the great corn product has made Nebraska one of the best meat-producing States of the West, and there is no other interest more prominent to-day than that of cattle-raising and fattening for market, as well as growing young stock for breeding purposes, in which business a vast amount of capital is profitably invested. Horticulture too has progressed far enough in the eastern part of the State to sustain a number of fruit-canning establishments.

The wholesale trade of the State is concentrated at Omaha, and carried on by about 200 firms.

For further detailed information see the biennial reports of the several State officers, the maps and descriptive pamphlets issued by the various railroad companies, and *The Industries of Omaha*. (F. II.)

NEEDLES. The needle is by no means a modern invention, but has been in use from pre-historic times, probably before the era of woven fabrics. These early needles were clumsy implements, made of wood, bone, or bronze, and even of gold, though these materials have long since been superseded by steel. Steel needles seem to have been introduced into Europe by the Moors, though it is not probable that they were the first inventors, since the Chinese claim to have used them from time immemorial. The first knowledge we have of the manufacture of needles in England is by a so-called "Indian," probably a Moor, who established this art in London in 1545, but it died out with him. The art of needle-making was then practiced in France and Germany, whence it had come from Spain, the home of the Moorish artificers. It was revived in England in the reign of Elizabeth, and by 1650 there was a numerous body of needle-makers established in London. They formed one of the London trade companies, having for their first crest the

tree of knowledge of good and evil, with a serpent twined round it. Afterwards a wreathed Moor's head was adopted.

At that period and until long afterwards the needles were made with square eyes, but this style of needle is now extinct. They were scoured by being wrapped in buckram, with emery-dust and oil, and rolled back and forth under the feet of the workmen. In 1700 a horse-mill was established for scouring and pointing, water-power not being used for this purpose till later. In the early period the needle-makers drew their own wire, cut it to length, flattened the eye end and punched the hole, a square punch being used as the easiest form. In 1793 drilled-eye needles were made, but these proved too expensive, and the old method was resumed. In 1800 stamps and dies to pierce the eyes of needles came into use, and in 1826 the drill was successfully applied, but it left the edge of the hole so sharp as to cut the thread. This was overcome by the burnishing process, which came into use about 1838. The needles were threaded in rows on hard steel wire, on which they were made to revolve rapidly by steam-power.

Up to 1840 needles had been hardened in water, which made many of them crooked. This was obviated by hardening in oil, which then came into use. The needle-pointing machine is an English invention. The pointing is done by a grooved grindstone, which is made to revolve at great speed, the needles being fed to it from an inclined plane. By the use of a revolving disc the wires are fed continuously and made to turn while pointing.

It is an interesting fact that round-eyed needles were made and used in China long before even the square-eyed ones were in use in Europe. In England the centre of the needle trade is the small town of Red-ditch—for no particular reason except that needles happened to be first made there. Aix-la-Chapelle in Prussia is the centre of the continental trade. Needles are now made in a great variety of shapes and applied to many different purposes, and the trade has become a very extensive and important one. The manufacture, as now carried on, is a remarkable instance of the division of labor, each needle having to pass through seventy pairs of hands before completion. The needle manufacture in America is not a particularly important one. It is classed in the census reports with the pin industry, there being in 1880 forty establishments for the manufacture of pins and needles, with a total product valued at \$1,378,023. (C. M.)

NEFF, FÉLIX (1798-1829), a Swiss missionary, was born at Geneva, Oct. 8, 1798. In early life he was a soldier, but in 1819 he engaged in missionary labors in neglected valleys of the higher Alps. He extended his work into similar districts in France, where he greatly improved the religious, moral, and physical condition of the inhabitants. In order to carry out his plan more effectually he obtained ordination in England in 1823 as an Independent minister. He died at Geneva, April 12, 1829, at the early age of thirty, worn out by his toil and hardships.

NEGLIGENCE. In American as in English law it is generally for the jury to say whether there has been negligence on the part of the defendant or not; there must, however, be evidence upon which intelligent men could reasonably and properly find the fact of negligence, or the court will withdraw the case from the jury and dismiss the complaint.

The burden of proof is upon the plaintiff, and when he has raised a presumption of negligence he is entitled to recover unless the defendant produces evidence sufficient to rebut that presumption.

The strict English rule in regard to contributory negligence has recently been modified in the courts of that country. There it was formerly held that a passenger in train of A. Company, though having no control over the driver, was so far identified with him

See Vol. XVII. p. 313 (p. 322 Am. Rep.).

See Vol. XVII. p. 315 (p. 324 Am. Rep.).

that he could not recover against B. Company for an injury caused by an accident to which the negligence of A. Company's driver contributed. This rule has been followed by the courts of Pennsylvania and one or two other States only, but has recently been repudiated in England.

The rule that negligence of a parent or guardian in permitting an infant to become exposed to danger is to be imputed to the infant so as to bar its right of action for injury resulting therefrom has been followed in New York, Massachusetts, Illinois, Indiana, Nebraska, and California, but repudiated in Pennsylvania, Vermont, Ohio, and Alabama.

A master is liable for the negligent acts of his servants in the course of their employment. He is not responsible for any such act with respect to matters unconnected with the general business in which they serve him.

The general rule in England, as well as in America, has been that a master is not liable to a servant for injuries received by reason of the negligence of a fellow-servant. In the case of one servant being put in command of others the English courts, as well as those of some of the United States, have held that the master was not liable for injury to a fellow-servant resulting from his negligence. In the U. S. courts and the great majority of the State courts the contrary rule has been followed. (T. R.)

NEGRO. For anthropological treatment of this race the reader is referred to the *ENCYCLOPEDIA BRITANNICA*. The present article is confined to the "Negro Race in America: its history, present condition, and future prospects."

In the year 1565 Don Pedro de Menendez, the founder of a Spanish colony at St. Augustine, Florida, introduced the first African slaves into territory subsequently included in the United States of America. But prior to this Sir John Hawkins, in October, 1562, organized the first expedition of English-speaking people to engage in the African slave-trade. Associated with him in this ignoble enterprise were Sir Lionel Ducket, Sir Thomas Lodge, M. Gunston, his father-in-law, Sir William Winter, M. Bronfield, and about 100 men as well able to fight as to perform the functions of sailors. The expedition went forward in three vessels: the *Salomon*, 120 tons burthen; the *Swallow*, 100 tons; the *Jonas*, a bark of forty tons. Hawkins landed his expedition at Tagarin, on the coast of Guinea, and by sword and torch secured 300 African captives, whom he subsequently bartered in Hispaniola at the ports of Isabella, Porto de Plata, and Monte Christo. In exchange for his living chattels he received from the Spaniards sugar, ginger, hides, pearls, etc.

Hawkins performed two other voyages as an importer of slaves, voyages characterized by great cruelties to the African villages he set upon and burned, and many of whose inhabitants he slew with the sword or bore away into captivity. His second slave-voyage was begun on the 18th day of October, 1564, and the expedition was composed of the same vessels with the exception of the *Jonas*, whose place was filled by the *Jesus*, of Lubeck, 700 tons burthen. The third voyage was begun on Oct. 2, 1567, and, after many hardships and perils, ended Jan. 25, 1568. All the slaves secured by the three slave-hunting voyages of Sir John Hawkins were stealthily disposed of in the northern ports of the Spanish-American colonies, because the Spanish government, jealous of the increasing fame and power of the English upon the seas, had issued orders to its colonial governors to exclude all British ships from their ports. Notwithstanding official opposition Hawkins found the Spaniards eager to purchase his stolen Africans; and thus did an Englishman open up the slave-trade between Africa and America.

In August, 1619, a Dutch man-of-war fell in with an

English vessel, the *Treasurer*, Captain Elfred, in the West Indies, and, having recaptured from her twenty slaves previously taken from a Spanish vessel, sold them to planters in the colony of Virginia. The *Treasurer* was owned by the Earl of Warwick and Gov. Samuel Argall, and had been sent out by the earl with an old commission from the Duke of Savoy authorizing her to seize Spaniards as lawful prize. The twenty negroes were a part of 100 Africans whom the *Treasurer* found in a Spanish vessel. The Dutch man-of-war was not engaged in the slave-trade, but, being short of provisions, exchanged the recaptured Africans for food. The Dutch introduced slaves into Manhattan (New York) in 1625; and the first lot landed in the Eastern colonies was brought to Massachusetts in the ship *Desire*, Capt. Peirce, Feb. 26, 1637-38.

In 1631 an African Company was chartered for thirty-one years to trade on the coast of Guinea between Cape Blanco and the Cape of Good Hope; and all other persons and traders were strictly prohibited from trespassing upon the exclusive rights of the patentees. The English colonies in the West Indies and America were now to be supplied with African slaves; and in order to facilitate its business of stealing Africans the company erected forts and factories on the coast of Guinea at great expense.

In 1662 Charles II. granted letters of incorporation for an African Company with exclusive rights; and it undertook to supply the British West Indies with 3000 African slaves annually. The king's brother, the Duke of York, and other gentlemen of quality, became enthusiastic members of the company. In 1672 the company surrendered its charter to the crown, when the "Royal African Company" was incorporated upon a joint stock. This company included among its members the king, the Duke of York, and other persons of rank and quality. Its capital stock was £111,000 sterling, and the grant embraced the territory between Port Sallee, in South Barbary, to the Cape of Good Hope. It did a thriving business for a while; but by the "Declaration of Right" in 1688, with other royal companies, it was compelled to surrender its charter. However, in the following year it entered into a contract to supply the Spanish West Indies with slaves from Jamaica. By the close of the seventeenth century Brazil and the West Indies had been well stocked with African slaves, and the British colonies in America were exchanging rum and fish for slaves in the Spanish-American colonies or importing them direct from the west coast of Africa.

Convinced as to the value of African slaves in its North American colonies, the British government began to take official notice of the slave-trade and inaugurated the eighteenth century by encouraging the traffic in human flesh. In 1702 "her most gracious majesty," Queen Anne, in a letter of instructions to her colonial governors, directed that her subjects "take especial care that God Almighty be devoutly and duly served," and that the "Royal African Company of England" "take especial care that the said province may have a constant and a sufficient supply of merchantable negroes at moderate rates." Having opened up the slave-trade in North America the English now proposed to levy a tax upon all slaves imported into British colonies. On April 18, 1707, the Board of Trade, in a circular letter to the English-American colonies, urged that a light tax upon slaves was the best means for "the well supplying of the plantations and the colonies with a sufficient number of negroes at reasonable prices." The board maintained that the chief point to be considered was that it was "absolutely necessary that a trade so beneficial to the kingdom should be carried on to the greatest advantage."

Stimulated by the British government and by the rivalry of the Portuguese, Spanish, French, and Dutch adventurers, the slave-trade grew to enormous proportions. Between the years 1679 and

1689 the annual importation was about 4500; and between 1698 and 1707 about 25,000 slaves were landed annually. But notwithstanding the large number of interloping vessels of all nations engaged in the slave-trade, England was the only power that clothed the action of its seamen with the majesty of national authority. Her slave-ships increased until she could undertake to steal Africans for other nations. The service that France had once performed for Spain England now undertook. In 1713 Queen Anne, of England, entered into a contract with King Philip V. of Spain, to import 144,000 negroes into Spanish America within the space of thirty years, and she advanced to Philip 200,000 crowns for the franchise, and agreed to pay a duty of 33½ crowns upon each slave. The agreement was known as "The Assiento," and was as follows: "Her Britannic Majesty did offer and undertake, by persons whom she shall appoint, to bring into the West Indies of America belonging to his Catholic Majesty, in the space of thirty years, 144,000 negroes, at the rate of 4800 in each of the said thirty years." The Assiento was considered of such great importance that it became the subject of stipulation in the preliminaries of the treaty of peace at Utrecht; and it was solemnly confirmed as the sixteenth article of that treaty. This enterprise, which constituted the Queen of England and the King of Spain the largest slave-traders in the world, seemed to promise great financial gain. Philip took one-quarter of the stock and gave his note for it; Anne reserved to herself one-quarter, and the remaining one-half she left for her loyal subjects. For twenty years the annual importation of slaves was about 15,000, divided between the Spanish and English colonies; and for the last twenty years there were imported in English ships 20,000 slaves per annum. The number of slaves imported continued to increase until just before the passage of the "Non-importation Act," when it had reached 41,000 per annum for the British-American colonies, and 97,000 carried to the Spanish-American colonies. Between 1680 and 1700 the African Company and private traders exported about 300,000 slaves from Africa; and from 1700 to 1786 from Africa to Jamaica alone 610,000.

The total number imported into the West Indies and British colonies from 1680 to 1786 may be carefully stated at 2,130,000, an annual average of 20,095. The loss at sea was about one-eighth of the entire 2,130,000 slaves imported. The fleet that was engaged in the slave-trade was without a parallel in the history of the world. In 1771 there were 192 slave-ships sailing from London, Liverpool, and Bristol, with a capacity for carrying 47,000 slaves. There were 107 ships from Liverpool alone, with a capacity for 29,250 slaves. From 1771 to 1776 the average annual slave-fleet was 150 vessels sailing from English ports alone, in addition to those vessels employed by the subjects of other nations and by the British colonists in America. For the half century of the slave-trade to America, from 1700 to 1750, the estimated loss of life upon the ocean was 250,000 Africans, who were cast into the deep. The loss upon the land from hunger, disease, overwork, and cruel treatment was about one-sixteenth of the entire number landed, which was, in the English West Indies, American colonies, Spanish and French possessions, about 3,000,000 souls.

The rapid increase of slaves in the British-American colonies led to the enactment of special laws regulating the new system of labor in vogue. The laws varied in the different colonies. In the Southern colonies, where many whites had sold their service for a specified period, the law of bondage recognized two classes, "servants for a term of years, and servants for life;" while in Massachusetts and other Eastern colonies slavery was established by statute. In those colonies where there was no statute legalizing slavery it existed in contemplation of law; and many laws were enacted

recognizing negro slaves as real, personal, and mixed property. Slaves were bought and sold at private and public sales; were disposed of by will, and, sometimes, manumitted under certain declaratory and restraining statutes. The slave codes of the colonies were quite similar. The slaves were excluded from the ecclesiastical, civil, and militia establishments. They were not competent to testify in any criminal or judicial proceeding, unless all the parties to the cause were negroes. In some colonies the master's power over the slave extended to life and limb; in others the correction was restricted to moderate corporal punishment. As a class the colonial slaves were governed rigorously: being overworked, underfed, thinly clad, and wretchedly housed. When old and infirm they were usually manumitted, and then sent forth to earn their own living. This was practiced to such an alarming extent that some of the colonial Legislatures required that masters emancipating old slaves should furnish a bond that they should not become a charge upon the community. The slaves were not allowed to receive instruction of any kind in schools or from private individuals. In rare instances they were received into the communion of the Christian church; but the custom was to abandon them to the most degrading and destroying ignorance. Their marriages were by common consent without the presence or official sanction of a clergyman. Their immorality was due to the system under which they were constrained to languish. In sickness they were without nursing, and rarely secured the service of a physician, and when they died they were thrown into the common ditch. The free negroes and mulattoes were taxed, without representation. They were admitted to the church, but were without a voice in ecclesiastical government. They were compelled to train with the militia of the parish in which they resided, and yet they were assigned to fatigue duty alone. They could not stand for any civil office; could not cast a ballot for any candidate for office. They were denied social intercourse with the whites, and were forbidden to consort with slaves. They were constrained to furnish their own instruction, since there was no provision made by the colonies for the education of their children. The opportunities for young men to secure remunerative positions were rare; and thus the free negroes of the colonies were confined to servile employments.

Notwithstanding the painfully obscure position the free negroes and mulattoes of the colonies occupied, many of them attained to a high degree of intelligence and virtue, and some of them accumulated considerable property. During the colonial period there were some able representatives of these people. Phillis Wheatley (1753-1794), the poetess; Paul Cuffee [q. v.] (1759-1817), navigator, merchant, and philanthropist; Prima Hall (1756-1789), soldier, politician, and grand-master of the first lodge of negro masons; Benjamin Banneker (1731-1806), astronomer, philosopher, and author; James Durlam (1762-1804), physician and chemist; Richard Fuller (1749-1829), mathematician, and others, were persons whose talents have attracted attention. They were not indifferent to the hardships under which their less fortunate brethren suffered, and their talents and character pleaded eloquently the cause of the oppressed.

Although slavery existed in all the British-American colonies, there was at all times more or less opposition to the system. A few years prior to the war of the revolution the agitation of the slavery question began to take definite shape. Letters of protest appeared in the colonial newspapers; the town meetings passed resolutions condemnatory of slavery, and instructed the representatives to the general courts to secure such legislation as would put an end to slavery. The movement assumed several aspects. An attempt was made to tax the slave-trade to its death; but this only gave the trade legal recognition, and emboldened the traffickers in human flesh. Nor was a tax levied against the

colonial slave-trade, as such. Slavery had been fostered by the crown; and every royal governor sent to the British-American colonies was strictly charged to give his official aid to the slave-trade. Until the "Stamp Act" and "Tea Tax" the people were loyal to the mother-country; and, therefore, the colonial agitation found few prominent adherents. From 1750 till the war of the revolution some efforts were put forth for the liberation of the slaves. James Otis, James Swan, and Nathaniel Appleton were the practical leaders of the agitation. The impending revolution was favorable to the enslaved blacks, and the free negroes and mulattoes lost no opportunity of making converts to the cause of universal freedom.

Although the free negroes of the colonies were exempted from militia service, they patriotically rallied with the colonists at the outbreak of the revolution. At the battle of Bunker Hill Peter Salem and Salem Poor distinguished themselves. When the army was reorganized, in the summer of 1775, both the "Committee of Safety" and the "Council of War" at Gen. Washington's head-quarters were averse to the employment of negroes as soldiers. But public sentiment was not friendly to such conduct on the part of a people who claimed to be struggling for liberty, and, after a few months of agitation, negro soldiers were incorporated into the "Continental Army." They shared the hardships, conflicts, and victories of the Continental troops. They were engaged in the battles of Rhode Island, Point Bridge, Germantown, Saratoga, Yorktown. Nor were the English indifferent to the value of the negro as a soldier. They offered him freedom and the pay and bounty of a British soldier as an inducement to enlist in the royal army. Some few hundred accepted the offer, and faithfully served in the English army till it was withdrawn by Sir Guy Carlton, when they sailed away with the retiring troops. The Americans acted with the same fidelity towards the negroes who had supported their standard in the war. In most of the colonies slaves as well as free negroes had been accepted as soldiers; and, while the slaves were manumitted, the masters were compensated.

Notwithstanding the anti-slavery feeling—which was almost wholly confined to the Northern colonies—before and during the war of the revolution, slavery was not checked to any considerable extent. Such slaves as had served as soldiers were *ipso facto* free; but the thousands who had performed agricultural labor, while they had been loyal to the American cause, were still in bondage. The slave-trade from the West Indies and Africa had practically ceased since the war of the revolution; but the inter-colonial trade in slaves continued. In the New England colonies there sprang up a movement among the people to rid themselves of an institution that had been established by the British government. Slavery was not extinct until nearly a generation after the Declaration of Independence. But while the Northern colonies desired the abolition of the institution of slavery, and sought to effect it by legislation and voluntary manumission, the Southern colonies clung to it as a basis of their present and future prosperity.

In the Constitutional Convention of 1787 the slavery question occupied a large place in the debates. The delegates from the Northern colonies were not more zealous for free ships than the Southern delegates were for slaves. Four questions were to be decided—the legal status of the slave; the right to reclaim fugitives from labor and service; the basis of Southern political representation, and the prohibition of the slave-trade. The delegates from the Northern States made some show of opposition to the slavery question, but finally yielded to the demands of the Southern delegates. An attempt to abolish the slave-trade by law was defeated by the Southern members; and the representatives of the Northern colonies effected a compromise by which the South was to have twenty years of the foreign slave-trade, and the North the

exclusive right to enact navigation laws. The Southern delegates insisted upon having the slaves of their section counted as three-fifths of their ratio of representation in Congress. They won their point; and the negro slave made his appearance in the Constitution as "a person;" and authority was secured to return any such person who might be a fugitive from "labor and service" to those to whom such labor and service were due.

Before the opening of the nineteenth century the Quakers of the Eastern and Middle States had shown their opposition to slavery. On Nov. 9, 1789, Benjamin Franklin, President of the "Pennsylvania Society for Promoting the Abolition of Slavery, and the Relief of Free Negroes unlawfully held in Bondage," had addressed a memorial to Congress praying that body to enact some law abolishing slavery. In 1800 Congress received a petition from Quakers, asking redress for some free negroes who had been unlawfully enslaved. Abolition societies were then forming. Public sentiment was being created in favor of liberty, and the triumph of the movement seemed to be but a question of time.

By the "Ordinance of 1787" slavery had been excluded from the "Territory of the North-west;" and all States formed out of that territory were expected to prohibit slavery by their constitution. In March, 1818, the citizens of Missouri petitioned Congress for permission to form a constitution and be admitted into the Union as a State. The question as to whether the fundamental principle of the republic was liberty or slavery was now for the first time raised. Missouri wanted a constitution establishing and protecting slavery; and after a struggle of nearly two years the cause of slavery triumphed, and the Missouri compromise was enacted.

On the part of the South the compromise was a gain by the extension of slavery and the admission of a new slave State. On the part of the North it was a guarantee of a prohibition of slavery in future States. But the Southern statesmen fought the battle for slavery over again when other States asked to be admitted into the Union. Kansas was saved to liberty only by the eternal vigilance of patriots, and by the expenditure of much treasure and blood.

The anti-slavery movement of the colonial period, and the consistent efforts of the Quakers, had at length aroused the public conscience that had nodded over this question for so long. At the very time the struggle between slavery and freedom was in progress in Missouri, Benjamin Lundy, the chief apostle of universal emancipation, was at St. Louis. Already in 1815 he had organized an anti-slavery society, "the Union Humane Society," at St. Clairsville, Va. In 1828 he made the acquaintance of William Lloyd Garrison, who subsequently became associated with him as editor of the *Genius of Universal Emancipation*, at Baltimore, Md. The free negroes of the United States began early to write and speak in behalf of their enslaved kinsmen; and the service they rendered the cause of freedom was both creditable to their brain and heart. Many of them served as conductors on the "Under-Ground Railroad," and made sacrifices to aid their escaping brothers to Canada, where they would be beyond the reach of United States marshals. During the period of the anti-slavery agitation more than 30,000 fugitive slaves found homes in Canada, while at least 21,000 were established in their freedom in the Northern States and territory.

The Abolitionists and negroes of the North were opposed by a violent and mobocratic spirit in all sections of the country. Anti-slavery papers and books, when sent South, were taken from the mail-pouches and burned. Persons travelling in the South were frequently suspected of anti-slavery sentiments and consequently cast into prison. In the North Garrison had been thrown into jail at Baltimore; Lovejoy's

press had been burned at Alton and his life taken ; Pennsylvania Hall had been destroyed at Philadelphia ; Abolition meetings had been broken up, and the right of free speech and free press generally denied to the friends of freedom.

In some parts of the South the free negroes were considerable in numbers, and while they might legally acquire property and secure to themselves the blessing of education, they were denied intercourse with the slaves lest they should incite them to acts of violence and bloodshed. And although the slaves were docile and tractable they were, nevertheless, capable of bitter resentment at times. Denmark Vesey, in South Carolina, "General" Gahiel and Nat Turner, in Virginia, with other negro insurrectionists, between 1797 and 1831, had taught the slaveholders the danger of underestimating negro courage. In 1839 an intelligent and brave African captive, named Cinque, led a number of his fellow-countrymen, who were being conveyed from Cuba to another Spanish island on board the ship *Amistad*, in a desperate effort for liberty, in which they slew their captors. The whites, whose lives they spared, were imprisoned, and, ignorant of navigation, they placed a Spaniard at the wheel with orders to sail for Africa. He obeyed in the daytime, but at night turned about and steered for the United States. Capt. Gedney, U. S. brig *Washington*, discovered the *Amistad* and brought her to New London, Conn. After a long and exciting trial the Africans were liberated. In 1841 an American slaver, the *Creole*, with 135 slaves on board, sailed from Richmond. In the early part of November, when the *Creole* was near the Bahamas, one Madison Washington, an intelligent and intrepid negro, led eighteen of his fellow-slaves in a revolt against their owners. They killed a slave-trader and wounded the captain and several other whites, and then put into Nassau, New Providence, where, after some waiting and much bitter diplomatic correspondence between the United States and England, they all obtained their freedom. The free negroes of the Northern States were excluded from the militia and denied, quite generally, the right to vote, although taxed. Their schools were separate, few in number, and poorly conducted. Frequently they were the objects of cruel and murderous mobs who sought them out in the seclusion of their homes and maltreated them. They were excluded from churches, confined to the galleries of theatres, denied entertainment at hotels, and were not permitted to travel as first-class passengers upon land or water. Nearly every State constitution contained the word "white" as a restriction of civil rights ; nearly every common-carrier company had special rules to apply to the negro ; nearly every community contained men and women who were always ready to denounce and abuse the blameless and inoffensive blacks.

In 1850 the original Fugitive Slave law of 1793 was altered by Congress so that a master could go into a free State and, without any regard to the laws of that State, claim a negro as his property and take him South. The negro was denied the writ of *habeas corpus* ; he could not testify in court, nor could he demand a trial by jury. The U. S. marshal of the district in which the alleged fugitive "from labor and service" was discovered was required to deliver him up, and was empowered to call the *posse comitatus* if the exigencies of the case required it. Citizens who attempted to aid the fugitive were liable to heavy fines. The slaveholders did not hesitate to avail themselves of the wide-sweeping provisions of this law, and its enforcement soon fanned the flame of anti-slavery sentiment of the free States into a blaze of indignation. Shadrach, a fugitive slave, had been rescued from a U. S. court-room at Boston by the friends of freedom ; and Thomas M. Sims, another fugitive, would have been rescued from slave-hunters had he not been arrested upon a charge of theft and then held as a fugitive slave. The rendition of An-

thony Burns by the U. S. marshal at Boston ; the *posse comitatus* of 100 respectable citizens of Boston ; the company of U. S. marines and artillery with shotted cannon ; the U. S. revenue cutter at the wharf, sent by the order of Pres. Pierce to convey the heavy-hearted and manacled slave back to the bondage from whence he had escaped, were the chief features of one of the most dramatic events in the history of the slave-power in America.

Next in historical importance was the DRED SCOTT CASE (*q. v.*). The opinion of the court was delivered by the Chief-Justice, Roger B. Taney, March 6, 1857. He maintained that neither persons of African descent, imported into the United States, nor the descendants of such persons, were citizens of the United States under the Constitution ; that the framers of that instrument never intended to confer upon them such a right ; that the only two references to them in the Constitution relate to them as property ; that a negro could not become a citizen, and that Dred Scott was not a citizen of Missouri, and, therefore, dismissed the case. From this opinion Justices McLean and Curtis dissented ; but the Chief-Justice spoke for the slave-power. The confusion, alarm, and dissatisfaction created in the North by the decision was unprecedented ; and the people, through public meetings called to denounce the decision of the court, and through the newspapers, defied the bold attempt to prostitute the Constitution for the destruction of human freedom.

During the administration of Pres. Buchanan the attention of the whole country was riveted on Kansas, where a desperate struggle for the extension of slavery over territory declared free by the Missouri Compromise was then taking place. Hardly had it closed in favor of freedom than the irrepressible conflict seemed to be transferred to the soil where slavery had first been planted in the limits of the United States. On Oct. 16, 1859, Capt. John Brown, at the head of 21 men, captured the U. S. arsenal at Harper's Ferry, Virginia, and held it until the 18th, when it was retaken by a company of U. S. marines. Brown's object was to emancipate the slaves of the States of Virginia and Maryland and not to take life except in self-defence. With five of his men he was tried by a court of Virginia, convicted, and hanged on Dec. 2. Though his attempt was thus easily quelled, it sent a thrill of terror through the slaveholding States.

Southern leaders insisted on new constitutional guarantees for the safety of their peculiar institution, while a majority of the people of the North demanded the perpetual exclusion of slavery from territory repeatedly dedicated to freedom. The Republican party organized to carry out this policy triumphed at the polls in November, 1860, and elected Abraham Lincoln to the presidency. The heated and unscrupulous partisans of slavery urged forward their States to secession and rebellion without waiting for his inauguration.

Although the war of the rebellion was brought on by the slavery question, both the Union and Confederate governments strove, during the early months of the conflict, to avoid it as an issue. The Union army surrendered fugitive slaves to rebel masters who were permitted to come within the lines in pursuit of their chattels. Gen. B. F. Butler shrewdly declared such fugitives contraband of war, but a great majority of Union officers surrendered the slaves who sought shelter in their camps from their masters. In Louisiana, South Carolina, and Kansas negroes were mustered into the military service of the United States as early as 1862, and before the spring of 1863 the U. S. government published a plan by which negroes, free and bond, were to be employed as soldiers. By the end of autumn 50,000 troops of this character were under arms. From the beginning to the close of the war there were 178,975 negro troops in the ser-

vice of the nation, who participated in 449 engagements and sustained a loss of 36,847. At Fort Wagner, Port Hudson, Chapin's Farm, Nashville, and upon other fields they won the confidence and approval of the military and civil leaders of the cause they so gallantly served. Doubtful and discriminated against in respect to their pay, bounty, and clothing, they were subsequently placed upon the same footing with their more favored white comrades. The war had propounded several difficult problems that the government was, at first, unprepared to solve; but history pointed to the past annals of the nation for guidance in the war of the rebellion. The exigencies of a war between Great Britain and her colonies in North America gave the negro his position as a soldier in the war of the revolution. In the second war between America and England the services of the free negroes of Louisiana had been secured upon the same terms as other troops. Their valor received the official notice of Gen. Andrew Jackson, and the applause of the national Congress. But in the war of the rebellion it became necessary to emancipate 4,000,000 slaves to save the Union. Pres. Lincoln's preliminary proclamation of emancipation was issued Sept. 22, 1862. He warned certain States, engaged in armed rebellion against the government and authority of the United States, that if they should be still engaged in rebellion on Jan. 1, 1863, he would then issue a final proclamation emancipating their slaves. On that date, accordingly, the President, by virtue of the war power, proclaimed the slaves of the enemies of the Union forever free.

After the war was over the government was charged with the grave and difficult work of reconstructing the insurgent States. Before the war had come to a close a Bureau of Refugees, Freedmen, and Abandoned Lands (see FREEDMEN'S BUREAU) had been established by an act of Congress. It made provision for needy and deserving white refugees and freedmen, and encouraged and fostered a system of education and agricultural industry. Pres. Andrew Johnson, who had succeeded Lincoln, at first posed as the "Moses of the negro," but later opposed the giving of the right of franchise to the black race. He vetoed every measure passed by Congress calculated to give protection and political rights to the freedmen. Congress passed over his vetoes the Thirteenth and Fourteenth Amendments to the Constitution, and all the legislation necessary to restore order, justice, and political government to the insurgent States. Slavery was rendered forever impossible, and the negro was made a citizen and a voter by amendments to the Constitution.

Pres. Johnson's defiant attitude towards Congress and his opposition to the enfranchisement of the negro, as well as his sympathy with and support of the rebel element of the South, led to great disorder and bloodshed in the insurgent States. Encouraged by the recognition from the President, and from the Northern politicians that supported him, some people of the South entered into a conspiracy against the legal results of the great war as engrafted upon the Constitution. A secret organization, called the "Ku-Klux-Klan," began a series of barbarous outrages. Negroes and loyal white men were whipped and their property burned. Hundreds were murdered in cold blood, and the larger Southern cities were the scenes of frequent riots. All the laws of Congress respecting the rights of the freedmen were set at naught and the work of reconstruction greatly embarrassed, if not defeated. The Legislatures of the insurgent States, controlled by men still possessed with the very ideas which had led to rebellion, passed laws that practically disfranchised the freedmen, and the acts regulating negro laborers made them the merest vassals of the soil.

The speedy failure of Pres. Johnson's policy of restoration left an open field for Congress to operate in. The insurgent States, being divided into five mil-

itary districts, all persons who took an oath of allegiance were registered as voters. New elections were ordered for State constitutional conventions; new constitutions were submitted to a vote of the people, and State officers were elected who were friendly to the amendments to the Constitution of the United States. These States were subsequently admitted to the Union and allowed representation in Congress. This was the beginning of the political career of the Southern negro. Inexperienced, ignorant, and pliable, he soon became the foot-ball of political parties, and the local administrations with which he identified himself were notorious for their imbecility and corruption. The negro, however, sinned less than he was sinned against, and the Republican State governments of the South were ultimately extinguished by tissue ballots and assassins' bullets.

During the period of reconstruction negroes were in the majority in the Senate and House of Representatives of some Southern States, while two became U. S. senators and a dozen were members of the House of Representatives. Fourteen held positions in the diplomatic and consular service of the government. The U. S. marshal for the District of Columbia, the tax-collector, the recorder of deeds, and the register of the treasury were, at one time, negroes, and all of them ex-slaves save one. There were about 600 negroes in the departments at Washington, D. C., and several thousand of them in the postal, revenue, and customs service in various sections of the country.

The negro is not so prominent in American politics now (1888) as he formerly was when the Republican party was in power. But there are unfailling signs that he is accumulating property and rapidly acquiring knowledge. In the District of Columbia, where the government emancipated the slaves by compensating their masters, the negro citizens pay taxes upon about \$8,000,000 of real property; in Georgia they are taxed for about \$11,000,000; in Louisiana, for about \$25,000,000; and in other States in an almost proportional amount. Their morals are improved, their social life more elevated, their deportment more correct, and their tastes more chaste and elegant.

The ninth census of the population of the United States seemed to indicate that the negro race in America was doomed to speedy extinction. From a population of about 4,500,000 in 1860 it had risen, according to the ninth census, to but 4,886,378 in ten years. But the census of 1880 exhibited that the race had reached 6,580,793, an increase of 34.67 per cent. in ten years. At present (1888) the negro school population of the former slave States is 2,020,219, and the enrolment is 1,048,659, a percentage of 55.8. They have 281 normal schools with 6207 students; 270 institutions for secondary instruction with 9970 students; 238 universities and colleges with 5119 students; 110 schools of theology with 1297 students; 16 law schools with 98 students; 22 schools of medicine, dentistry, and pharmacy with 208 students; 40 schools for the deaf, dumb, and blind with 139 students; and, adding the 661 schools for negroes in the Northern States to the 18,794 for the freedmen, there are 19,455 public schools with a total enrolment for the race, as far as reported, of 1,127,839. But this does not include the negroes and mulattoes in the schools of the North where no discrimination is made as to color or nationality. There are more signs of improvement among persons heretofore held in bondage and the descendants of such persons than in the small communities of Northern negroes, who, contented with their condition, make little effort to improve their opportunities. They are the servant class as a rule, although there are worthy exceptions, and make little or no progress. However, in the larger cities of the Northern States negroes have branched out into lucrative business enterprises, and by industry, frugality, and ability have attained to high and honorable business standing. Prejudice is yielding to a better feeling toward this race among the

more enlightened, and wherever character and talent are exhibited they have been appreciated and applauded. It is different in the old slave States, since the prejudices and customs of centuries will not yield to nobler sentiments in a few decades. When the freedman acquires both education and property he will return to politics as a potent but peaceful factor; and his rights, so long denied, will be accorded him as the irresistible logic of civilization. Meanwhile, the friends of humanity, in all sections of a common country, will create a public sentiment friendly to the negro as a citizen, as a laborer, and as a man. Within two centuries the black race will have been merged into a composite American nationality, and the legends of its wrongs will have been wrought into a literature that will thrill the heart of the civilized world with passionate grief.

List of Authorities Consulted:—Hakluyt's Voyages; Holmes' American Archives; Court and Times of James First; Chalmers' American Colonies; Hildreth's History of the United States; Palfrey's History of New England; Force's American Archives; Voyages of the Elizabethan Seamen; Some Account of the Trade in Slaves from Africa, as Connected with Europe and America; Astley's Voyages; Eward's West Indies; Josselyn's Voyages; The Hutchinson Papers; The Madison Papers; The Journals of Congress; Elliot's Debates; Hurd's Bondage and Freedom; Mott's Sketches, etc. (G. W. W.)

NEHLIG, VICTOR, a French-American painter, was born at Paris in 1830. He studied under Abel de Pujol and Cogniet. He settled at New York in 1856, and was made a member of the National Academy in 1870. Several of his pictures relate to American history and romance. Among these are Gertrude of Wyoming, Hiawatha and Minnehaha, and Pocahontas.

NÉLATON, AUGUSTE (1807-1873), a French surgeon, was born at Paris, June 17, 1807, being son of a captain of the Imperial guard, killed at Wagram. He studied medicine and surgery under Dupuytren, and received his degree in 1836. He became adjunct professor in the faculty of Paris in 1839, and after a competitive examination in 1851, professor of clinical surgery. In 1844 he published his *Eléments de pathologie chirurgicale*, which established his reputation as an expositor. The work was enlarged by his pupils and passed through many editions. In 1856 Nélaton was admitted to the Academy of Medicine, and in 1867 to the Academy of Sciences. His professional practice extended throughout France and even beyond its borders. In 1862 he astonished the world by his cure of Garibaldi's wound, received at Aspromonte two months before Nélaton reached him. In 1866 he was made surgeon to Napoleon III., and having effected a remarkable cure in the case of the prince imperial, he was made grand officer of the Legion of Honor, and senator. He died at Paris, Sept. 22, 1873. His lectures were noted for their clearness and his operations for their almost magical success. With the simplest possible means he seemed to achieve the most important results. His improvements in surgery were happy modifications of pre-existing methods rather than entirely original processes. He assisted in the *Rapport sur les Progrès de la Chirurgie* (1867), and published some special treatises.

NELSON, DAVID (1793-1844), clergyman, was born near Jonesborough, Tenn., Sept. 24, 1793. He graduated at Washington College, Va., in 1810, and studied medicine at Danville, Ky., and at the Philadelphia Medical School. He was surgeon of a Kentucky regiment in the war of 1812. For a time he was a skeptic, but, returning to the religious belief in which he had been trained, gave up his medical practice and became a Presbyterian minister in 1825. After preaching in various parts of Tennessee and Kentucky, he removed in 1830 to Marion co., Mo., where he established a college. He was an advocate of emancipation and in 1836, on account of disturbances arising from this cause, he removed to Quincy, Ill., where for a time he

conducted a training school for missionaries. He died at Oakland, Ill., Oct. 17, 1844. He was the author of *The Cause and Cure of Infidelity*, which had an extensive circulation.

NELSON, THOMAS (1738-1789), a signer of the Declaration of Independence, was born in York co., Va., Dec. 26, 1738. He was educated at Trinity College, Cambridge, England, and while on his way home in 1759 was elected to the house of burgesses. He was member of provincial conventions in 1774-75, and was made colonel of the Second Virginia regiment, but resigned on being elected to the Continental Congress. Here he signed the Declaration of Independence. He opposed the sequestration of British property; he made large advances from his private property for the benefit of the State, and was thereby greatly embarrassed. In 1781 he was governor of Virginia, and called out the militia to oppose the British, who were then ravaging the State. He died at Yorktown, Va., Jan. 4, 1789. Two of his brothers were officers in the revolutionary army.

NELSON, WILLIAM (1825-1862), general, was born at Maysville, Ky., in 1825. He entered the navy in 1840, and commanded a naval battery at the siege of Vera Cruz in 1847. He rose to the rank of lieutenant, and in 1858 was on board the Niagara, which carried back to Africa the negroes taken from the slaver Echo. At the outbreak of the civil war he was on ordnance duty in Washington, and was sent to command the gunboats on the Ohio. Being placed under the authority of the Secretary of War, he organized camps in Kentucky for the mustering of Union troops. He was made brigadier-general Sept. 16, 1861, and commanded the second division of Buell's army at the battle of Shiloh. He took command of Louisville when it was threatened by Gen. Bragg. He was made major-general of volunteers, July 17, 1862. In a personal quarrel with Gen. Jefferson C. Davis, occasioned by his overbearing disposition, he was shot and killed, Sept. 29, 1862.

NEMOURS, LOUIS CHARLES PHILIPPE RAPHAEL D'ORLEANS, DUC DE, was born at Paris, Oct. 25, 1814. He was the second son of King Louis Philippe, but was educated as one of the people at the Collège Henri IV., and gave especial attention to science. In 1834, after he had served two campaigns in the field, he was made marshal. In 1836 he went to Algeria, where he rose to the rank of lieutenant-general. In 1840 he married the Duchess of Coburg-Gotha (1822-1857). The premature death of his elder brother gave him increased importance, but though he was diligent in performing public duties his popularity was never great. At the outbreak of the revolution of February, 1848, he was in command of a body of troops and he accompanied the Duchess of Orleans when she made an ineffectual appeal to the chamber of deputies. After assisting the royal family to escape to England, he fixed his residence at Claremont. He remained quiet during the reign of Napoleon III., but after his downfall in 1870 obtained permission to return to France, and was soon restored to the list of generals. Even then he did not busy himself in the attempts at a fusion of the monarchical factions. In September, 1873, with his nephew, the Duc de Chartres, he visited the Comte de Chambord at Frohsdorf. In 1879 he was placed on the retired list.

His son, Louis, Comte d'Eu, born April 28, 1842, married the eldest daughter of Dom Pedro II., Emperor of Brazil, and is a marshal of the Brazilian army. His second son, Ferdinand, Duc d'Alençon, was born July 12, 1844, and became a captain in the French artillery. He married Sophia, daughter of Duke Maximilian of Bavaria. In 1886 republican jealousy required him to leave the army and depart from France.

NETTLETON, ASAHEL (1783-1844), evangelist, was born at North Killingworth, Conn., April 21, 1783. He graduated at Yale College in 1809, studied theology

at New Haven, and was licensed to preach in 1811. He was ordained in 1817, but still continued the work of revival preaching to which he had devoted himself. After laboring with great success in Massachusetts, New York, and Connecticut, he went to Virginia in 1827, and to Great Britain in 1831. He was appointed professor of pastoral theology in the seminary founded at East Windsor, Conn., in 1832, and without accepting the chair delivered lectures to the students. He died at East Windsor, Conn., May 16, 1844. Rev. Dr. B. Tyler edited his *Remains and Sermons* and published a *Memoir* (1844), but he was most widely known by the collection of hymns bearing his name.

NEUKOMM, SIGISMUND (1778-1858), a German composer, was born in Salzburg, July 10, 1778. He was partly instructed by Haydn, and in 1804 became director of the German opera at St. Petersburg, but retired on account of ill health. He taught music at Vienna and Paris, and in 1816 went to Rio de Janeiro. In 1821 he returned to Paris, living at Talleyrand's house, and went with him to England in 1830. Towards the end of his life he became blind. He produced about 800 compositions of all kinds—operas, cantatas, symphonies, songs, etc. His most noted works are his oratorios *Mount Sinai* (1831) and *David* (1834), which are still performed. He died at Paris April 3, 1858.

NEUMANN, KARL GOTTFRIED, a German mathematician, was born May 7, 1812, at Königsberg, where his father, Franz Neumann, was professor of physics and mineralogy in the university. Here he was trained, but in 1838 he became privat-docent in mathematics at Halle, and in 1863 professor extraordinary. He afterwards held professorships at Basle, Tübingen and Leipzig. He has given special attention to mathematical problems connected with heat, light, and electricity. Among his publications are *Theorie der Electricitäts- und Wärmeverteilung in einem Ringe* (1864); *Theorie der elektrischen Kräfte* (1873); *Hydrodynamische Untersuchungen* (1863).

NEUTRALITY. The rules formulated by the Treaty of Washington, 1871, have added to the duties of England and the United States as neutrals, but, owing to a difference of opinion as to their interpretation, other nations have not been invited to accede to them.

A government may not sell munitions of war to a belligerent, but its subjects may, provided they sell indifferently to both parties, and the transaction is a purely commercial one. A belligerent has the right of seizing such goods as contraband, when on their way from the neutral state to the enemy. The *bona fide* sale of a ship intended for war, by citizens of a neutral power, is a commercial venture and is not forbidden by international law, but the difficulty of distinguishing between such a sale and the organizing of a hostile expedition has led England to prohibit such sales to belligerents altogether.

In the case of the ship *Alabama*, built at Liverpool, England, during the American civil war, for the Confederate States, the British authorities were notified of the purpose for which she was being constructed, but allowed her to sail, without armament, which she subsequently received by two other English vessels from the same port. A great deal of damage was done by this vessel to American commerce, the claims for which were subsequently submitted to arbitration, the award being in favor of the United States, on the grounds that Great Britain had failed to use due diligence, and that after the escape of the vessel the measures taken for its pursuit and arrest were so imperfect as to lead to no result, and therefore could not be considered sufficient to release Great Britain from the responsibility already incurred; also that the ship was on several occasions freely admitted into the ports of the colonies of Great Britain, instead of being processed against, as it ought to have been. (See ALABAMA CLAIMS.)

There are well-known exceptions to the general free-

dom of neutral commerce with belligerent powers. Certain articles are said to be contraband of war. A complete list of goods always to be deemed contraband, and therefore liable to seizure, has never been made. The main point is whether the article is intended or would probably be applied to military purposes. In England and America the court before which the goods are brought will inquire into all the circumstances of the case and condemn or release them accordingly. Any treaty stipulations will of course be taken into consideration. The Supreme Court of the United States has said that articles manufactured and primarily or ordinarily used for military purposes in time of war are always contraband, while articles which may be and are used for purposes of war or peace may or may not be contraband. Of the same nature with the carrying of contraband goods is the transportation of military persons or despatches in the service of the enemy: a neutral vessel transporting the forces or despatches of one belligerent is liable to confiscation, if captured by the other. The United States have contended that this applies to diplomatic agents, the contrary, however, being maintained by England and the Continental nations. Where the ship and cargo do not belong to the same person, the contraband articles only are confiscated. The articles must, however, be taken *in delicto*, in the actual prosecution of the voyage to an enemy's port.

Another exception to the general freedom of neutral commerce in time of war is as to the trade to ports blockaded by one of the belligerents. While a neutral subject is under no positive duty imposed by the law of nations to abstain from blockade-running, he is yet exposed to the chance of losing his ship and cargo if unsuccessful. The duty of a neutral state consists simply in letting its subjects engage in such traffic at their own risk, and abandoning them to the prize courts of the belligerent who may capture them. A blockade must actually exist and be carried on by an adequate force, and not merely declared by proclamation, to render commercial intercourse with neutrals unlawful. Notification of the existence of the blockade, however, is essential, unless actual knowledge thereof can be proved against the person charged with its violation. An act of violation is essential to a breach of blockade; as either going in or coming out of the port with a cargo laden after the beginning of the blockade. A mere intention to violate is not sufficient ground for condemnation. The intent must exist, however, to constitute the *delictum*, and must be inferred from the ship's papers, acts of the owners, officers, etc. (T. R.)

NEUVILLE, ALPHONSE MARIE ADOLPHE DE (1836-1885), French painter, was born at St. Omer, May 31, 1836. Though his predilection was always for art, he studied law in accordance with the wishes of his family. He passed his examinations successfully, but still devoted his time to drawing. He received some lessons from Picot, but soon left his studio. His first painting, *A Scene from the Siege of Sebastopol*, was exhibited in 1859 and received a medal. Delacroix gave the young artist advice and encouragement. He illustrated Guizot's *History of France* and some other works, but soon devoted himself to paintings of battles and soldier-life. In 1864 he achieved marked success with his *Chasseurs and Zouaves in the Streets of Magenta*; in 1866 with his *Zouave Sentinel*. In the war of 1870 De Neuville was commissioned as an engineer officer and took part in some engagements, but his chief object was to obtain material for his art. His *Bivouac before Le Bourget* (1872) was purchased for the museum at Dijon, and his *Last Cartridges* (1873) obtained for him admission to the Legion of Honor. Among his latest works were *The Cemetery of St. Privat* (1880), *The Dispatch-Carrier* (1881), and *Rorke's Drift*, a scene from the *Zulu war*. He died at Paris May 19, 1885. His works are strongly realistic, yet full of romantic

suggestions. They have been popularized by photographs and engravings.

NEVADA. This State lies east of California and extends to the 114th meridian W. from Greenwich. Its remarkable geological features have been largely discussed under **GREAT BASIN** (*q. v.*). In spite of the manifest sterility of a large part of its surface

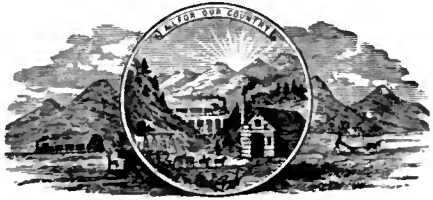

there was a time when it was thought to give promise of rivaling California in prosperity. In 1858 its rich silver mines were discovered and in 1861 it was separated from Utah, of which it had formed a part, and organized as a Territory. In 1864 it was admitted as a State, though still having much less than the full ratio of population required for a single representative in Congress. The population, which by the census of 1860 was only 6857, had probably quadrupled, and it was expected to increase rapidly. In 1870 it was 42,491, and in 1880 it reached 62,266, showing an increase of 46 per cent. for the decade. In the presidential election of 1880 the total vote was 18,343, the Democratic majority being 879. In the presidential election of 1884 the total vote fell off to 12,771, the Republican majority being 1615. In November, 1886, the total vote for governor was 12,362, the Republican majority being 594. These returns indicate that the present population scarcely exceeds that of 1880. It is certainly less than half of the average required for a representative in Congress (154,325).

The failure of Nevada to realize its early expectations is due not merely to the aridity of the larger portion of its surface, which prevents profitable agriculture, but also to the diminution in amount and value of the products of its mines. Their enormous output for several years had astonished the world. The sudden excess of silver violently disturbed the ratio of the precious metals and so alarmed the nations of Europe that they joined in demonetizing silver. The depression of the silver market of the world reacted disastrously on the "Silver State." Congress, however, has endeavored to sustain its interests, not only by maintaining the double metallic standard which other nations have discarded, but by ordering the secretary of the U. S. treasury to coin \$2,000,000 or more of silver each month. This law still holds in spite of protests of more than one secretary of the national treasury. But physical causes also contributed to the depression of the people of Nevada. The bonanzas of the Comstock mines were exhausted. The ores, taken from great depths at greatly increased expense, showed a very low average assay. Deep mining was finally abandoned and all the interests of the State suffered in common with the one which had given Nevada its early promise and bright prospects.

Since 1885, however, in the upper levels of the famous Comstock mines there have been discovered valuable deposits of ore, which were overlooked while the search was directed chiefly to bonanzas, or masses of almost pure silver. Some of these mines, after an interval of five or six profitless years, have again begun to pay dividends. Mines were discovered and opened in other parts of the State. In 1887 the bullion from the Comstock mines exceeded \$5,000,000, more than twice the amount for 1885. In 1888 the total output for the State was estimated at \$8,000,000.

Live-Stock.—Grazing is the next most important

interest to mining. Sheep-walks and cattle-ranges have become numerous in the northern counties, though less than a fourth of the total area is devoted to this purpose. The counties of Washoe, Elko, and Humboldt take the lead, but others are advancing in this respect. While the native bunch-grass, and even some varieties of the sage brush which everywhere abounds, have been found excellent food for cattle, the nutritious alfalfa has been largely introduced for this purpose. In the peculiar climate of the Great Basin the grass is cured on the soil without human aid. In 1887 there were in Nevada 17,683 milch-cows, valued at \$638,256; 317,059 oxen and other cattle, valued at \$6,949,933; 674,486 sheep, valued at \$1,153,371; 14,543 hogs, valued at \$77,339; 44,654 horses, valued at \$2,461,449; and 1657 mules, valued at \$121,251. There has been no loss in Nevada from pleuropneumonia, which has made such ravages elsewhere. Cattle from Nevada are largely shipped to San Francisco.

Agriculture.—Although the greater part of the soil is unfit for agriculture, there are fertile regions, especially in the valleys. Here the climate and soil are well adapted to the raising of cereals and vegetables. The fruits of Nevada are of excellent flavor and quality. At the New Orleans Industrial Exposition in 1884-5 Nevada made a very creditable display of productions, mineral and vegetable. To this State were awarded the first premiums for wheat and for potatoes, and the silver medal for apples.

Irrigation.—A proper system of irrigation and legal regulations for the use of water are greatly needed in Nevada. While there are in some places corporation ditches and several Legislatures have discussed the subject and passed various laws, the State has not yet undertaken to provide storage reservoirs in which water could be collected during the flood season and be distributed as needed during the dry season. Until this is thoroughly and effectually done, nine-tenths of the water will continue, as at present, to run to waste.

Constitutional Amendments.—The State Constitution requires that an amendment shall be passed by two successive Legislatures, and then be submitted to a vote of the people and ratified by them before becoming part of the organic law. As the population is still fluctuating and their needs and desires are rapidly changing, these restrictions on their legislative action have been found too severe for their circumstances. It has, therefore, been proposed to alter the Constitution so that a proposed amendment, if passed by a two-thirds vote of the Legislature, may then be submitted to the people. This amendment is to be voted on at the election in November, 1888. Ten other amendments are pending at various stages. One abolishes the office of lieutenant-governor, others relate to the power of the Legislature and its time of meeting, and one imposes on the State instead of the several counties the duty of providing for infirm and indigent citizens. Another proposed amendment is to make women eligible for school-officers, while another is to deprive Mormons of the elective franchise. There is a general tendency, in the interest of economy, to diminish the number of State and county officers, and to lessen public expenses.

Finances.—The total assessed valuation of real and personal property, and of the net proceeds of mines during the year 1887, was \$27,997,339. From this the State obtained, by a tax of 90 cents on \$100, a revenue of \$251,976. The amount paid by all the counties (save one) was \$225,374. The total State receipts for year ending Jan. 1, 1887, were \$794,702.58. The expenditures for the same time were \$702,670.52. The total amount raised by taxation was \$537,499. The State debt was \$484,484, funded partly at 4 and partly at 5 per cent.

Railroads.—There are in Nevada altogether 922 miles of railroad. The Central Pacific is the grand trunk line of the State. It has 450 miles of main line;

its chief branches are the Virginia and Truckee, running south from Reno to Virginia City, 52 miles; the Nevada and Oregon, running north from Reno, has 28 miles in Nevada; the Nevada Central, running south from Battle Mountain to Ledy, 93 miles; the Eureka and Palisade, running south to Eureka, 90 miles. Some of these have also smaller local branches. On all railroads in the State Indians are allowed to ride free.

Education.—In 1887 the total number of children under 21 was stated to be 14,537, of whom 14,236 were white. The attendance in the public schools was reported at 9828, but four districts failed to report. From the State school fund over \$63,000 was apportioned among the districts. This fund contained \$147,632.53 in cash, while State and U. S. bonds swell the total to \$281,256. Part of the school fund was used in building the State Insane Asylum, at Reno. In 1885 the Nevada State University was transferred from Elko in the eastern, to Reno in the western part of the State. In February, 1886, the new building, costing about \$20,000, was opened with two instructors and 56 students, chiefly in the preparatory department. There is a State Orphans' Home in Carson City, with 52 inmates.

Indians.—There are in Nevada about 9500 Indians; 4500 Pah-Utes, 300 Pi-Utes; Shoshones, 4200, and Washoes, 500. About 1300 remain permanently on the three Indian Reservations, Pyramid Lake, Walker Lake, and Duck Valley. Nearly 9000 of them wear citizens' dress. About 900 speak English, and about 400 can read. On the reservations the schools are well attended, but elsewhere there is no provision for their instruction. The Indians are generally industrious laborers, but they live around the towns and rely on the white population for employment and support.

(J. C. M.)

NEVIN, JOHN WILLIAMSON (1803-1886), theologian, was born at Shippensburg, Pa., Feb. 20, 1803. He was of Scotch-Irish ancestry, and graduated at Union College, 1821, but on account of feeble health spent the next two years at home. Then entering on the study of theology at Princeton, he became so well versed in Hebrew that when Dr. Charles Hodge went to Europe in 1826, Nevin was appointed to supply the chair of Oriental and Biblical Literature. His handbook of *Biblical Antiquities*, then prepared, had a wide circulation. On being licensed to preach in 1828 he was called to the newly established Presbyterian Theological Seminary, at Allegheny, Pa., as assistant professor of Hebrew and Biblical Literature. Ten years were spent here, during which his character as a leader of religious thought was manifested. On the one hand he opposed slavery, infidelity, and worldly tendencies in the church; on the other he opposed the increasing tendency to individualism in religion. He was thus led to give prominence to the historical church as a divine institution. Regarding the German Reformed Church as more true to the principles and usages of the Reformation he joined that denomination in 1839. He was then made professor of theology in its seminary at Mercersburg, Pa., and in 1840 he succeeded Dr. F. A. Rauch as president of Marshall College there. His tractate on *The Anxious Bench* (1843) caused a brisk controversy within and beyond the Reformed Church. In 1844 Dr. Nevin received as his colleague Dr. Philip Schaff, whose *Principle of Protestantism* he had already translated into English. In 1846 he published *The Mystical Presence*, which set forth the doctrine of the Reformed Church in regard to the Lord's Supper. The theological views here presented met with opposition even in the Reformed Church, but Dr. Nevin earnestly and ably maintained them as the historical creed of the church. With his friends he established in 1849 the *Mercersburg Review*, for the defence and exposition of this theology, and conducted it with ability for four years, when he relinquished the task to others. In 1851 Marshall College had been re-

moved to Lancaster, Pa., and united with Franklin College, and Dr. Nevin retained the presidency until 1853. He then retired from professorial work, but continued to preach and to write. He had also much to do with the preparation of a new English liturgy for the Reformed Church. In 1861 he undertook the duties of professor of history in Franklin and Marshall College, and in 1866 again became its president, and held the office for ten years. Thereafter he lived in retirement at Lancaster until his death on June 6, 1886. Dr. Nevin was one of the foremost theologians of America. He set forth the person of Christ as the true centre of theology, the visible church as his body, and its ministers and ordinances as the appointed channel of divine grace. His views were not summed up in any single work adequate to his reputation, but were given in occasional treatises and discourses and in his contributions to the *Mercersburg Review*. Besides *The Mystical Presence* may be mentioned *The Apostles' Creed: Its Origin, Constitution, and Plan* (1849); *Revelation and Redemption* (1870); *The Revelation of God in Christ* (1871); *Christ and His Spirit* (1872).

His son, **ROBERT JENKINS NEVIN**, during the civil war commanded a battery of artillery, and afterwards took orders in the Protestant Episcopal Church. He has been for some years rector of the American Church of St. Paul's within the walls at Rome, Italy.

NEW ALBANY, a city of Indiana, county-seat of Floyd co., is on the N. bank of the Ohio River, nearly opposite Louisville, on the Louisville, New Albany, and Chicago, the Louisville, Evansville, and St. Louis, and the Jeffersonville, Madison, and Indianapolis Railroads. Two other railroads are in process of construction. The city has a court-house, U. S. government building, 4 national banks, 1 daily and 4 weekly newspapers, 18 churches and 10 schools, and De Pauw Female College. New Albany is the largest manufacturing city in Indiana, having 142 industrial establishments, comprising iron and brass foundries, rolling-mills, flour, woollen, and cotton-mills, tanneries, shoe, chair, basket, and box factories, potteries, stone and brick yards. The glass-works are the largest west of Pittsburgh. New Albany is lighted with gas, and has water-works with 3 reservoirs. Its property is valued at \$9,000,000, and its public debt is \$400,000. Settled in 1814, it was incorporated in 1846. In 1880 it had a population of 16,423, but it is now estimated to have over 20,000.

NEWARK, the principal city of New Jersey, county-seat of Essex co., is on the Passaic River, 3 miles above Newark p. 370 (p. 379 Bay and 9 miles W. of New York. Am. Rep.).

Four railroads maintain frequent communication with the metropolis. The city, excellently laid out with well-paved, shady, and well-drained streets, and several small parks, has somewhat of a rural appearance in spite of its abundant factories, which entitle it to be called the "Birmingham of America." It occupies a site about five miles long by five broad, and on the river front there is a line of docks over a mile long. It has public buildings for city, county, and government purposes, 11 national banks, 5 savings banks, and other financial and insurance companies, 120 churches, a high-school, and 30 public schools, besides excellent private schools. Over 400 manufactories here produce a great variety of articles, including brass- and iron-work, machinery, carriages, saddlery, harness, trunks, hats, hardware, and jewelry. The annual product is valued at \$60,000,000. The city has gas and electric lights, a good supply of water from the upper Passaic, and a paid fire department. Newark was settled in 1666 by a Puritan colony from Connecticut, and the inhabitants have long maintained a high moral and religious character. It received a city charter in 1836, and soon afterward the foreign element largely increased, as it still continues to do. The population in 1880 was 136,508, and is now estimated to exceed 150,000. Its suburbs extend west to Orange, and south nearly to Elizabeth.

NEWARK, a city of Ohio, the county-seat of Licking co., is on the Licking River, 33 miles N. E. of Columbus, on the Baltimore and Ohio, the "Panhandle," and other railroads. The North Fork of the Licking is here crossed by four iron bridges. Newark has a court-house, 5 hotels, 2 national banks, 1 other bank, 2 daily and 4 weekly newspapers, 20 churches, and 5 school-buildings, besides 2 commercial colleges. The industries comprise 3 foundries, making stoves and furnaces, 5 wagon-factories, 2 machine-shops, 4 flouring-mills, 3 planing- and woollen-mills. Newark, one of the early settlements of Ohio, was incorporated in 1826. It has a park, gas-, and water-works. Its property is valued at \$6,000,000, its public debt is \$125,000, and the public expenses \$19,000 yearly. It carries on a good trade in coal, grain, and live-stock. The population in 1880 was 9600.

NEW BEDFORD, a city and port of entry of Massachusetts, half-shire town of Bristol co., is on the estuary of Acushnet River, 3 miles from Buzzard's Bay, 56 miles from Boston, and 31 from Providence. It is the terminus of the New Bedford and Taunton branch of Old Colony Railroad. The New Bedford bridge, 4000 feet long, crosses the estuary to Fairhaven. It has a Doric granite city-hall, court-house, U. S. government building, public library, 3 hotels, 5 national and 2 savings banks, 2 daily and 4 weekly newspapers, 30 churches, a high-school, with fine building, and many public schools. Several of the churches have fine edifices. New Bedford ranks third among the American cities in cotton manufacture. There are 5 corporations, owning 12 mills, running 475,000 spindles. There are also 2 foundries and manufactories of twist-drills for boring metals, cordage, glass, silver-plated ware, carriages, boots, and shoes. The whale-fishery, commenced in 1755, was the principal pursuit of the citizens for a century, but since its decline their attention has been turned to manufactures. At one time over 300 whaling vessels belonged to this port, but the number is now reduced to 80. There are several refineries of sperm and whale oil. New Bedford was settled about 1650 chiefly by Quakers. It was incorporated in 1787, and received a city charter in 1847. It was originally part of the town of Dartmouth, which was incorporated in 1664. The city is regularly laid out, has gas- and water-works, and a park of seven acres, and is noted for the elegance of its private residences. A broad drive of four miles around Clark's Point leads to a strong U. S. fort of granite, and commands a fine view of the sea. The assessed valuation of property is over \$32,000,000; the public debt is \$1,250,000, and the yearly expenses about \$475,000. The population of New Bedford in 1880 was 26,485, and by the State census of 1885 it was 33,393.

NEW BERNE, a city and port of entry of North Carolina, the seat of Craven co., N. C., is at the junction of the Neuse and Trent Rivers, on the Atlantic and North Carolina Railroad, about 90 miles N. E. of Wilmington. The Neuse is here 2 miles wide, and navigable for steamboats. Across the Trent there is a bridge half a mile long. New Berne has a court-house, 2 hotels, 2 banks (1 national), 2 daily and 3 weekly newspapers, 15 churches, and 8 schools. There are railroad-car-shops, 2 machine-shops, wood-pulp-factory, cottonseed-oil-mills, 5 saw-mills, and an oyster-canning establishment. New Berne was settled in 1710 by Swiss immigrants, and was for a time capital of the State. It ships early vegetables to the Northern markets. Its property is valued at \$1,500,000. The population in 1880 was 6443.

NEWBERRY, JOHN STRONG, geologist, was born at Windsor, Conn., Dec. 22, 1822. Two years later his father removed with his family to Cuyahoga Falls, Ohio. The son graduated at Western Reserve College in 1846, and at Cleveland Medical College in 1848. After spending a year in Europe he began practice at Cleveland in 1851. His strong inclination for natural science led him to become assistant surgeon and geolo-

gist of the U. S. Survey of Northern California and Oregon in 1855. He also joined Lieut. Ives, in 1857, in exploring the Colorado River for 500 miles from its mouth, and in 1859, under Capt. Macomb, he completed the exploration of this river and its branches. During the civil war Dr. Newberry was connected with the U. S. Sanitary Commission, and directed its operations in the Mississippi Valley. In 1866 he was made professor of geology in the School of Mines, Columbia College, N. Y. While still holding this position he was made, in 1869, State geologist of Ohio. Prof. Newberry has been president of the American Association for the Advancement of Science, and is connected with the principal scientific societies of the country. As a geologist and palæontologist he holds a foremost place. His publications include *The Geology, Botany, and Zoology of Northern California and Oregon; Geology of the Colorado Expedition; Geology of the San Juan Expedition; Reports of the Geological Survey of Ohio; Iron Resources of the United States*, and other works on geology and palæontology.

NEW BRITAIN, a city of Connecticut, in Hartford co., is on the New York and New England Railroad, 102 miles from New York and 8 miles from Hartford, with which it is connected by a branch of New York, New Haven, and Hartford Railroad. It has handsome streets and residences, and two parks, the larger containing 40 acres, and a good supply of water from a reservoir of 175 acres. There are 2 national banks, 1 savings bank, 1 daily and 5 weekly newspapers, 10 churches, and 13 public school-buildings. The high school, State normal school, State armory, Masonic temple, and institute library are fine buildings. The manufactures are builders' hardware, cutlery, hooks and eyes, harness-trimmings, knit-goods, hosiery, etc. Settled in 1634, it was originally part of Farmington, and was incorporated as a city in 1872. In 1880 the population of the city was 11,800, and of the townships 13,979.

NEW BRUNSWICK, a city of New Jersey, county-seat of Middlesex co., is at the head of navigation on the Raritan River, 33 miles S. W. of New York, on the New York division of the Pennsylvania Railroad. It is the terminus of the Delaware and Raritan Canal, which is 75 feet wide and 7 feet deep. Besides the court-house and county buildings, it has a city hospital, orphans' home, a free library, 4 large hotels, an opera-house, a Masonic hall, 2 national banks, a savings bank, a Catholic cathedral, 17 churches, 4 weekly and 3 daily newspapers. It is noted for its educational facilities, being the seat of Rutgers College, which was founded in 1771, and is under the patronage of the Reformed Church. Connected with it is the theological seminary of that denomination, an observatory, and a State agricultural college, with a model farm of 100 acres. The industrial establishments comprise 3 iron-foundries, a brass-foundry, and manufactories of India-rubber, hosiery, paper, shoes, lamps, bronzes, fruit-jars, needles, paper-boxes, carriages, doors, sash and blinds. The town site rises rapidly from the river. It is lighted with gas and electricity, and has water-works. The municipal debt is \$1,516,000, and the annual expenses in recent years exceed \$400,000. The town was settled in 1681, and received its first charter in 1730, but the present charter dates from 1784. The population in 1880 was 17,166.

NEWBURGH, a city of New York, the seat of Orange co., is situated on the W. bank of the Hudson River, 60 miles N. of New York and 83 miles S. of Albany, 41° 20' N. lat. and 74° W. long. In front, for about 8 miles, the river is 1½ mile wide and from 30 to 60 feet deep. This body of water, known as Newburgh Bay, is protected by mountains, which form a semicircle. The city, as it recedes from the river-front, rises in terraces until a height of 300 feet is reached. Here on a plateau are the finest residences, while the whole furnishes an attractive view from the river. The New York Central and the New York and

New England Railroads on the opposite side of the river maintain communication by means of a steam-ferry from Fishkill. The Erie Railroad has two branches terminating in Newburgh, and the New York, West Shore, and Buffalo Railroad passes through the city. The Ontario and Western and the Lehigh and Hudson River bring large amounts of coal to be shipped here. Newburgh has 3 national banks, a savings bank, a hospital, a free library of 16,000 volumes, 24 churches, a high-school, and other public and private schools, 2 daily and 4 weekly newspapers. It is supplied with water from a lake 3 miles distant, has gas and electric light, and a volunteer fire department of 8 companies. The manufactures comprise woollen and cotton goods, carpets, agricultural implements, soap, oil-cloth, paints, brushes, plaster, tiles, flour, and beer. There are also foundries, boiler-works, and ship-building-works. Orange county is noted for its extensive dairies and excellent butter. The Orange powder-works are noted for the excellence of their product. Newburgh was noted during the revolutionary war, and at its close the American army was disbanded here June 23, 1783. The old Hasbrouck house, since known as the "Washington Headquarters," is owned by the State of New York, and is open to visitors. Newburgh was incorporated as a city in 1865. Its property is assessed at about \$9,000,000, and there is a debt of \$350,000. Population in 1870 was 17,014; in 1880 was 17,327.

NEWBURYPORT, a city of Massachusetts, and a shire-town of Essex co., is on the estuary of the Merrimack River, 35 miles N. E. of Boston. It has 4 national and 3 savings banks, 18 churches, a free library, Putnam Free School, a high-school, and other schools. The industrial works comprise an iron-foundry, 6 large cotton-factories, 9 shoe-factories, and manufactories of pumps, carriages, hats, combs, and silverware. There are 1 weekly and 2 daily newspapers published here. Shipbuilding has been long carried on here, and many vessels are owned in the city. Plum Island, which helps to form the harbor, has a hotel. Dummer Academy is in the town of Newbury, from which Newburyport was separated in 1764. The latter was chartered as a city in 1851, and, in 1880, had 13,538 inhabitants.

NEWCOMB, SIMON, astronomer, was born at Wallace, Nova Scotia, March 12, 1835. He removed to the United States at an early age, and while teaching school in Maryland was employed in 1857 as a computer for the *Nautical Almanac*. In 1861 he was appointed professor of mathematics in the navy and stationed at the naval observatory. He superintended the construction and erection of the telescope now used there, which was then the largest in the world. In 1874 he was secretary of the U. S. commission for the observation of the transit of Venus, and he organized the several expeditions then sent out. In 1877 he was made superintendent of the *American Ephemeris and Nautical Almanac*. In 1884 he was also made professor of mathematics and astronomy in Baltimore. His astronomical researches have had reference to the orbits of the asteroids, solar parallax, action of the planets on the sun, etc. The results have been published partly by the Smithsonian Institution and partly in the *Ephemeris*. His *Popular Astronomy* (1878) is an excellent treatise. He has since published textbooks on *Algebra* (1881); *Geometry* (1881), and *Trigonometry* (1882). He has also given much attention to political economy and finance, and has published *A Critical Examination of the Financial Policy during the Southern Rebellion* (1865); *The A B C of Finance* (1877), and many articles in periodicals.

NEW HAMPSHIRE is well known as the "Granite State" from its famous White Mountains. It had by the U. S. census of 1880 a population of 246,391. According to the same authority its land area

is 9005 square miles, thus giving a density of 383.4 per mile.

Finance.—The number of savings banks in New Hampshire in 1886 was 67; the number of depositors was 125,273, an increase of 4037 within a year. The amount of deposits was \$46,631,913, an increase of \$2,804,557. The laws of the State respecting the taxation and supervision of savings banks are unchanged.

The State debt is (approximately) \$2,838,000, and was reduced about \$160,000 in 1887. The debts of the several counties, so far as returned, amounted in 1886 to \$44,086.49; but the assets of the counties, in cash and other property, far exceeded that sum. The total indebtedness of cities and towns (including village precincts) is \$4,171,673.61, a decrease of \$214,467.11 since the preceding year. The total net State and local indebtedness amounts to \$7,009,673, and as the assessed valuation of the State is \$173,658,499, and the population (assuming that it has increased in the same ratio since 1880 as in the decade preceding that date) is 367,000, the entire debt, of every description, amounts to a trifle over 4 per cent. of the taxable property of the State, and to about \$19 per head of the population. The taxes assessed for all purposes in 1886 were \$2,646,526.33, being \$1.52 on each \$100 of taxable property.

Religion and Education.—The Congregational denomination is the most numerous in the State, having 188 churches, and the Presbyterians, affiliating with the Congregationalists, 6 churches. The Congregational ministers number 184, and the Presbyterian 5. The members of both these denominations aggregate 20,749; and there are, connected with the Sabbath-schools as instructors and pupils, 21,660. The Methodists have 125 churches, and 12,879 members. They have 107 pastors in charge of churches, and 76 local preachers. Their Sunday-schools number 136; the officers and teachers of same, 1823; the scholars, 13,739; probationers, 1400. The Baptists have 80 churches, and 8782 members; 75 Sunday-schools; 1111 officers and teachers of same, and 8502 scholars. Their ordained ministers number 82, and licentiates 11. The Free-will Baptists constitute an important sect in New Hampshire, where it took its rise about the year 1780. It now embraces within the State 109 churches, 129 ministers, and 8893 members.

In 1885 the "district system" of common schools, which had prevailed in the State for two generations, was abolished by law and what is known as the "town system" was established in its place. Boards of education, the members of which serve for three years, are now chosen by the towns and have the entire supervision of their schools. They have authority "to provide schools at such places and times as in their judgment shall . . . give all the scholars of the town as nearly equal advantages as may be practicable." There had been complaint that the pupils in the small and remote districts, under the former system, sometimes fared poorly in respect to facilities for instruction, and one chief purpose of the new law was to place all pupils, so far as may be, on the same footing.

The "literary fund," derived from the tax on bank capital and on savings bank deposits of non-residents and divided for the support of schools among the several towns of the State, according to their apportionment of the State tax, amounted in 1886 to \$38,833.21. The whole amount raised for public education was \$617,472.16. The number of schools was 2770, including 526 grade and 57 high-schools. The whole number of scholars enrolled was 64,221, and the number attending private schools, not registered in the public schools, was 5832.



State Institutions.—The State prison is situated in Concord and has 132 inmates. They are employed in the manufacture of bedsteads under a contract. The expenses of the prison exceed the earnings by about \$2500 annually. The Industrial School (formerly State Reform School) is situated in Manchester and is intended for the reformation and instruction of juvenile and female offenders, in which design it has been fairly successful. The number of inmates in 1886 was 112. The Asylum for the Insane has been from its inception growing yearly in extent and value. The number of patients in April, 1886, was 317, of whom nearly three-fifths were females.

Industry.—A new and productive employment has grown up in New Hampshire, to large dimensions, within a few years past. This is the entertainment of "summer visitors," who resort thither for health or pleasure. For this purpose not only all available points on the sixteen miles of sea-coast, but a multitude of airy and commanding positions among the mountains and around the lakes are covered with hotels and boarding-houses, which are kept open between June and October and are thronged during July and August and a part of September. It is, of course, the cool atmosphere and the fine scenery that offer such attractions to visitors, and these fully compensate the inhabitants for their rough and sterile soil. The agriculture of New Hampshire had fallen to a low ebb. In raising cereals she could not compete with the States and Territories of the West, whose easily-grown products were transported to the sea-board at the lowest rate of expense. A small number of farmers in the vicinity of the cities and larger towns could supply the markets with other products which brought in a fair return, but considerable quantities of outland, which had once been cultivated, had been abandoned to weeds and bushes. Now that the summer hotels and boarding-houses have become so numerous, and even hundreds of farmers' houses are filled with boarders, the demand for the products of agriculture is greatly increased and new encouragement is offered for the cultivation of the soil. A market is found at the farmer's door for every esculent that he can raise. The effect of this new industry cannot fail to be widely beneficial to the State, and is already visible in the improved agriculture and general prosperity of the inhabitants of certain localities. No careful estimate has been made of the value of this business, in a year, but it is safe to say that it amounts to millions, and is still increasing, with every prospect of continuing for an indefinite period.

History.—As Belknap's *History* is referred to as especially trustworthy in its account of the early transactions in New Hampshire, it is proper to state that since the last issue of that valuable work, in 1831, several ancient documents have been discovered which throw new light upon some of those transactions. Belknap states that John Mason, the patentee of New Hampshire, sent out at his own charges the first colony which was planted there, at Little Harbor, in 1623. But recently-found evidence indicates that David Thomson, the leading man of that colony, had himself obtained a grant of land and brought out the colonists at the expense of three merchants of Plymouth in England, and though it is probable that Mason was cognizant of the grant and adventure, yet that he expended no money in settling his American grants until six or seven years later. Belknap, and most other historians, represent that Mason's patents gave him simply the ownership of the soil and no authority to set up a government upon it. But in April, 1887, a copy of a patent was unearthed, purporting to have been issued by King Charles I., of England, to John Mason, dated in 1635, and confirming to him and his heirs the territory of New Hampshire, and adding thereto the power of government. The existence of this royal grant had

been asserted early in the last century, but was doubted, mainly on the ground that no action was known to have been taken or attempted under it. New Hampshire is doing much for the preservation of the materials of her early history. There have been already published fifteen volumes of her MS. records, eight of province and State papers, four of town papers and three of revolutionary records, and more are to follow. The Legislature has also made appropriation to procure copies of the documents in the British archives illustrative of her early history. (C. H. B.)

NEW HAVEN, the largest city of Connecticut and county-seat of New Haven co., is See Vol. XVII. on a sandy plain at the head of New p. 394 (p. 403 Am. Rep.) Haven harbor, into which the small rivers Quinnipiac, Mill, and West flow. It is 74 miles N. E. of New York, on the New York, New Haven, and Hartford, and the Shore Line. There are three railroads to Boston and three other railroads. Across the rivers are several bridges, the largest being that over the Quinnipiac near its mouth. The city is now co-extensive with the original "town," but each has its own administration. On the public green of 16 acres, in the centre of the city, stands the building used as a state-house down to 1873, while New Haven was, jointly with Hartford, the capital of the State. Opposite the green is the city-hall, an imposing structure, the county court-house, the U. S. government building, and various churches. Other important buildings are those of Yale College (*q. v.*) and the Sheffield Scientific School, the hospital, two orphans' asylums, the public high-school, and the Hopkins Grammar School. There are altogether 34 schools, 61 churches, 7 national banks, 3 savings banks, and 3 other banks. Seven daily and 10 weekly newspapers are published here. Of the more important publications *Silliman's Journal of Science* is famous in its department, and the *New Englander* is of high repute as a literary periodical.

New Haven is largely engaged in manufacturing. According to the U. S. Census of 1880 it had altogether 587 manufacturing establishments, with a capital of \$9,793,737, employing 15,156 hands, and producing to the value of \$24,040,225 yearly. The chief products are hardware, wire, locks, clocks, corsets, carriages, guns, pistols, rubber goods, paper, matches, furniture. The harbor is shallow, yet a large coasting trade is carried on, especially in coal and iron, but the foreign trade, formerly extensive, has been transferred in great measure to New York city. Long Wharf is 3480 feet in length; the U. S. government has constructed a breakwater surmounted by a lighthouse. A jetty has been built at the entrance of the harbor. New Haven is finely laid out, and the streets are beautifully shaded with elms and other trees. It is bounded on the north by two ranges of hills, terminating in the East and West Rocks, which present precipitous faces towards the city. Besides the public green it has ten small parks or squares, the Yale College Athletic grounds, and a private park. On the border of the town is the picturesque East Rock Park, containing 350 acres, which has been improved partly by the liberal gifts of private citizens. On the highest part of the rock stands a soldiers' monument, 125 feet high. The city is lighted with gas and well supplied with water. The assessed valuation of city property is \$50,000,000, the public debt of town and city is about \$1,500,000, and the yearly expenses about \$950,000.

New Haven was settled in 1638 by wealthy London merchants, who desired to found a colony to be governed by Bible laws. This colony was united in 1662 to that of Connecticut, but New Haven was recognized as a capital of the State until 1874. It was incorporated as a city in 1784. Its population in 1880 was 62,882, but as the city bounds have since been enlarged it now exceeds 77,000.

NEW JERSEY by the U. S. census of 1880 had 1,131,116 inhabitants, and thus ranked as the nineteenth State. In 1887 there were reported 374,011 children between 5 and 18 years of age; of these 224,109 were enrolled at schools, but the schools had actually accommodations for 200,000 only.



For this reason the compulsory educational act of 1885 cannot be enforced. There were 825 male teachers with an average monthly salary of \$64, and 3177 female teachers with average salary of \$41. The State Normal School had a total enrolment of 239, with an average attendance of 206. The school fund in 1888 was reported at \$2,267,455; in addition to which there are riparian leases (for lands now under water) valued at \$1,009,759, and an agricultural college fund of \$116,000 (see RUTGERS COLLEGE). The income from the school fund for 1888 was \$275,512. Besides this there were school taxes amounting to \$1,511,820, of which \$1,465,268 were expended.

The State Insane asylum at Morristown had 1073 patients for the year 1887, of whom 873 remained at the close. The asylum at Trenton had 865 patients for the year, 707 remaining at the close. The expense of these asylums in 1888 was \$165,328.45. The expense of the county lunatic asylums for that year was \$78,742. The State supported 89 feeble-minded children in 1887, mostly at Elwyn, Pa., at an expense of \$23,492, but in 1888 an asylum was opened at Vineland, N. J., for this class. The State school for the deaf has over 100 scholars. Provision is made for the blind at asylums in New York city and Philadelphia, there being 31 at the former and 10 at the latter, for whom the State appropriated \$14,689.

The State Soldiers' Home has 328 inmates, the total since its establishment being 14,725. Its receipts for 1888 were \$33,814, and its expenditures \$33,593. In 1887 the Legislature appropriated \$125,000 for a home for disabled soldiers at Kearny, on the Passaic River. The cost of this home was reported at the end of 1888 to be \$113,305.55. The militia of the State comprises 53 companies of infantry, forming 7 regiments, 2 Gatling gun companies and 1 of sea-coast artillery. They have altogether 306 officers and 3693 men. A camp for practice has been formed at Sea Girt, containing 119 acres. The annual expenditure for militia in 1888 was \$114,968.

The State prison contained in 1888 a total of 1380 prisoners, the average number being 877, of whom 857 were males. The receipts for the year were \$65,617 and the expenses \$162,859. Since 1885 the prisoners have been employed on piece-work. This system has not proved so economical as that of hiring out the labor by contract, the State having now the responsibility for both quality and quantity of work. The governor has recommended the imposing of indeterminate sentences (see PRISON DISCIPLINE). The Reform School at Jamesburg had 441 inmates during the year, there being 269 at the close. The State Industrial School for Girls had 67 inmates.

In 1884 the Legislature passed an act to compel all corporations to pay on real estate the same tax as individuals, the rate being limited to 1 per cent., and the main stem of railroads and the waterway of canals being exempted. Taxes were also allowed to be assessed on the real estate of railroads and canals for local purposes. The corporations resisting, the courts decided most of the provisions of the act to be constitutional. Under this act the State revenue derived from railroads increased from \$717,562 in 1884 to \$1,075,000 in 1886, besides local taxation amounting to \$372,364. There were altogether 97 railroad and

canal companies, whose property was valued at \$192,980,343.

On Nov. 1, 1888, the receipts of the State fund for the year were reported at \$1,504,124, and the State held stocks, bonds, and other securities to the amount of \$1,027,487. The amount of outstanding loan on the State war-bonds was \$1,169,300.

In 1886 a State Board of Health and Bureau of Vital Statistics was formed, and local boards of health were required to be formed in each city and township. A State Board of Agriculture was also established.

Considerable interest attaches to the recent movements looking toward the settlement and cultivation of the great tracts of waste and sandy plain land which cover nearly one-third of the State's area, principally towards the south-east. The natural features of this plain are much as follows: The surface has not generally a dead level, but is for the most part marked by a succession of low ridges of sand running parallel to the coast, and presenting much the appearance of old, yet not very old, sea-beaches. The whole region is well supplied with flowing streams; and its lower depressions are generally swampy. The swamps are generally overgrown with the white cedar (*Cupressus thyoides*), which affords valuable timber, and after being cleared the swamp-lands are often profitably utilized in the culture of cranberries. Some of the swamps are underlaid with well-preserved stores of timber from coniferous trees. The extraction and working of this long-buried supply of sound and still very useful wood form an important industry at certain places (as at Dennisville). Another industry of this region was formerly the extraction and working of the abundant, but somewhat uncertain, supply of bog iron-ores or limonites. These ores, though poor in iron, are easily smelted and make excellent castings. The once numerous iron-works of this region were all abandoned on account of the failure of the local supply of charcoal, due to the cutting of the main part of the forest growth. The ores, however, when worked out locally are reputed to have the quality of self-restoration, due largely to the growth in them of those species of diatoms which incorporate in their siliceous frustules a large percentage of iron, which they extract from the waters which flow into the ore-beds. The abundance and tractibility of these ores, and the excellent finish assumed by the castings made from them, may yet restore to the old workings some of their former value. There are locally found good supplies of peat, which is a useful fertilizer and may yet become valuable as fuel. Certain of the peaty deposits are reputed to make excellent brown mineral paints, presumably those which combine iron with their peaty constituents. At many points the sand of this region is extensively utilized in the manufactures of glass-ware. There are large supplies of a dark and coarse brown sand-stone which is extensively used for foundations and occasionally for general building purposes. This stone is easily wrought and becomes very hard on exposure to the weather. Several navigable streams penetrate the region, and there are not a few good water-powers already developed. The old stock of pine belonged chiefly to the dwarfish Jersey or scrub-pine (*Pinus inops*); comparatively little of it is now found, since the charcoal-burners have made great havoc with it, and the largest trees have for many years been cut and sawed into a coarse and strong description of lumber. Great forest-fires prevail almost every spring and summer; and the suppression of these is the first requisite to the restoration of the old woodland growth.

The soil of the so-called "pines" of New Jersey is for the most part far better than a stranger would suppose from its appearance. There are large tracts which are sparsely settled, yet which are naturally good grass-lands and are capable of supporting a large agricultural population. Still, as a rule, considerable

skill is required to manage these light lands profitably. The Vineland tract, centring in the town of the same name, has been the most noted and in some ways the most successful of the attempts at colonizing the waste lands of this State. The Hammonton colony affords another instructive example of what thrift and intelligence can do with unpromising materials. The town of Lakewood, in the extreme north-east of the comparatively unsettled region of the State, has become noted as a health-resort, and is especially frequented in winter. The principal element among the settlers in the best known of the recent colonies in this section is made up of native Americans, chiefly from New England and the State of New York. Egg Harbor City is a German colony, where the making of light wines is a specialty. Near Estellville and at Alliance, near Vineland, are experimental colonies of expatriated Russian Jews, driven to this country by the anti-semitic movements in their native land. The principal crops of this region are the small fruits—grapes, blackberries, raspberries, strawberries, cranberries, with potatoes, sweet-potatoes, and other hoed crops, and the garden vegetables. Rye does extremely well in some parts. Dr. J. E. Garretson, in his *Brushland* (1882), gives interesting notes of the creation of a profitable farm in this region out of a tract which, though of very unpromising appearance, must have contained in itself to an unusual degree the elements needed to foster success in any agricultural enterprise. The region above discussed is for the most part bounded landwards by very fertile light lands; and in some parts the line of demarcation is very plain and unmistakable between smiling fertile grass-lands and fields of sand covered with a relatively scanty herbage. It is noteworthy, however, that the unfertile region is singularly rich in plant-species, it being the habitat of many Southern forms which nowhere else occur so far to the northward. This region is traversed by nearly all the lines of railway which reach the many seaside resorts of New Jersey. There are other parts of the State which are quite as unpromising in an agricultural point of view as this. The extensive clay-region in the central portion of the State, so important for its terra-cotta, its fine pottery, and its excellent fire-brick, is in part almost inarable.

The *seaside resorts* of New Jersey are very numerous and important. Almost from Sandy Hook to Cape May its sea-bathing places form a nearly continuous succession of towns and villages, of which there are more than 50 in 100 miles of coast. South of Sandy Hook the coast is everywhere sandy. The beach in Monmouth county is generally elevated and even bluff, and is backed by a fertile region; southward the New Jersey coast is much lower and is made up chiefly of a succession of sand-spits and low islands which shield from the open sea a succession of shallow bays, much resorted to by sportsmen for game-birds and fish. The more southern bathing-places are generally safer, having a more shelving beach with but little undertow. The largest of the seaside resorts are Long Branch, Asbury Park, Ocean Grove, Atlantic City, and Cape May City.

The old boards of the proprietors of East Jersey and West Jersey still exist, the former having its head-quarters at Perth Amboy and the latter at Burlington, but both long ago surrendered all except their proprietary rights. The East Jersey proprietors have latterly laid claim to large tracts of unoccupied lands over which other parties have in some cases exercised the rights of ownership for 200 years, on the ground that no transfer of title is now on record. This has led to costly litigation, and has strengthened a movement to have the old proprietary rights finally adjudicated, thus terminating all disputes as to claims founded upon any defect of the registration of title-deeds during the colonial period.

(C. W. G.)

NEW JERSEY, COLLEGE OF. This institution of learning, commonly called Princeton College, was founded in 1746. Like all our early colleges it was primarily established to raise up an educated ministry, "to be a seminary of true religion and sound learning," especially for the Presbyterian Church. Prominent ministers and laymen of the Presbytery of New York, which then included a large part of New Jersey, after various ineffectual efforts, succeeded in obtaining a charter. The only record of this charter is in Book C., p. 137, of the Colonial Commissions and Charters, and is as follows: "Mem. of a Charter for a Colledge. A charter to incorporate sundry persons to found a colledge passed the great seal of this province of New Jersey, tested by John Hamilton, Esq., president of His Majesty's council and commander-in-chief of the province of New Jersey, the 22d day of October, 1746." This charter was never recorded, but under it the Rev. Jonathan Dickinson, pastor of the Presbyterian Church in Elizabethtown, N. J., where he also had a flourishing academy, was appointed president and the college was established at Elizabethtown, the first session beginning in the fourth week of May, 1747.

President Dickinson died Oct. 7, 1747, and the students, about twenty in number, were placed under the care of the Rev. Aaron Burr, pastor of the Presbyterian Church in Newark, to which place the institution was now removed. An enlarged and more liberal charter was granted by his Excellency, Jonathan Belcher, Esq., the Governor of New Jersey, to which the "Great Seal of the Province of New Jersey" was affixed Sept. 13 and the charter was issued Sept. 14, 1748. The trustees named in it, who with two exceptions were Presbyterians, accepted the charter in a meeting held at New Brunswick, N. J., Oct. 13, 1748. At Newark, Gov. Belcher presiding, the trustees unanimously elected the Rev. Aaron Burr president, Nov. 9, 1748. His inauguration took place upon the same day, and at a later hour the first commencement was held. Of the six members of the first class five became ministers of the gospel. The sixth was Richard Stockton, one of the signers of the Declaration of Independence. The first honorary degree was that of A. M., conferred upon Gov. Belcher.

Liberal subscriptions were obtained, but the contributions were wholly inadequate to the execution of the designs of the trustees. Rev. Samuel Davies and Rev. Gilbert Tennent were sent to Great Britain and Ireland to solicit additional benefactions. Their mission was very successful, many hundreds of pounds having been contributed by persons of different denominations and in various walks of life. The General Assembly of the Church of Scotland even ordered a national collection, and among the contributors were the Bishop of Durham and a descendant of Oliver Cromwell.

The second commencement had been held at New Brunswick on the last Wednesday of September, 1749, but for the next seven years "the academical exercises were generally performed in the county courthouse" at Newark. The funds obtained by Messrs. Davies and Tennent were devoted to the erection of a college edifice. As the site of this "the little village of Princeton was fixed upon as the most convenient situation, being near the center of the colony on the public road between *New York* and *Philadelphia*, and not inferior in the salubrity of its air to any village upon the continent."

The people of Princeton made liberal contributions in land and money, "200 acres of woodland, 10 acres of cleared land, and one thousand pounds proc. money (\$2400)." By suggestion of Gov. Belcher "the edifice sacred to liberty and revolution principles," which was erected at Princeton, 1754-57, was named *Nassau Hall*, in honor of King William III., "a branch of the illustrious House of Nassau." Hence the institution itself is often called *Nassau Hall*. This building, 176

feet long and 54 wide, with slight central projections in front and rear, was the largest edifice in the colonies at the time of its erection. It was three stories high with a basement, and was surmounted by a cupola. It contained sixty rooms for all purposes, public and private, chapel, library, recitation rooms, dining-room, and chambers, of which there were 49 to accommodate 147 students. It was constructed of stone, and the president's house in the vicinity was of brick. Although burned down in 1802 and again in 1855, its main walls still stand, and, except for the unsightly towers at the ends, it presents substantially its original appearance.

The curriculum of studies was equal to that of any of its sister colleges, consisting of Latin, both written and spoken, Greek, to be translated into both Latin and English, French, Hebrew, geography, algebra, geometry, navigation and astronomy, natural philosophy, ontology, logic, rhetoric, and ethics, together with theology for those who intended to become ministers of the gospel. The president, assisted by two tutors and an occasional lecturer, was expected to give instruction in all these branches in addition to his regular services as a minister. So varied were the accomplishments of President Burr, as had been those of President Dickinson, that he was equal to the work.

When the college was removed to Princeton in 1756 there were about 70 students, and the number increased rapidly. Gov. Belcher died Aug. 31, 1757. President Burr prepared and preached the funeral sermon while very unwell himself. Prostrated by his great labors, he never rallied, but died Sept. 24, 1757, just two days before the commencement.

Rev. Jonathan Edwards, perhaps the greatest mind this country has produced, was elected to succeed Mr. Burr, his son-in-law. Inaugurated Feb. 16, 1758, he had just entered upon his work when he died of inoculation, March 22, 1758. Thus the prospects of Nassau Hall appeared darker than before.

After a vacancy of eighteen months Rev. Samuel Davies was chosen president, entered upon his duties July 26, 1759, and was inaugurated Sept. 26, 1759. But the bright hopes he had excited were doomed to disappointment; for on Feb. 4, 1761, "this brilliant genius, in the midst of his rising reputation and growing usefulness, suddenly resigned his breath, to the inconsolable grief of the whole society and universal lamentation of all good men."

Rev. Dr. Samuel Finley was now elected president, entered upon his duties in July, 1761, and was inaugurated Sept. 30, 1761. The college rapidly increased in numbers, and was flourishing in all respects. The classes of 1765-66 each contained 31 students. Again were expectations bitterly disappointed. A peculiar fatality seemed to attend the office of president. Dr. Finley died July 17, 1766. Thus within the space of twenty years the college had been called to mourn the loss of five presidents—Dickinson, Burr, Edwards, Davies, Finley—an array of the most eminent ministers our country had yet produced.

The college had graduated nearly 300 students and had obtained considerable reputation on both sides of the Atlantic. The Rev. Dr. John Witherspoon, of Scotland, was now elected president, but at first declined, and the Rev. Samuel Blair, an alumnus of high promise, was chosen in his place. He magnanimously declined when he learned that Dr. Witherspoon would accept the appointment if again offered. This was done, and Dr. Witherspoon began his long and successful administration, Aug. 17, 1768. Strenuous had been the efforts made to increase the inadequate funds by subscriptions, lotteries, and in other ways. Yet in 1767 the college had only £2815 in proclamation money (\$7500). Gov. Belcher had left 474 volumes to the library, which in 1764 had been increased to 1200. Dr. Witherspoon obtained large gifts for it from his friends in Great Britain, and subscriptions were made in the colonies from Massachusetts to Georgia, so

that nearly £8000 were collected by 1775, of which the Phillips family in Boston gave £500. Mr. John Williamson, of Virginia, had given £100 sterling to found a professorship of theology, to which Rev. John Blair was elected in 1767. This was the first chair endowed, but owing to the inadequacy of the funds he resigned in 1769 and Dr. Witherspoon discharged these duties in addition to his many others. He was assisted by three tutors. In 1771 Wm. C. Houston was appointed professor of mathematics and natural philosophy. In 1779 the Rev. Samuel Stanhope Smith was made professor of moral philosophy and subsequently of theology.

Dr. Witherspoon was very active and energetic, and extended the course of study. The number of students, which had fallen off directly after Dr. Finley's death, now began to increase, and from this time until the outbreak of the revolution in 1775 the average of the classes graduated was 22. The exercises of the college were greatly interrupted by the war and no commencement was held from 1775 to 1779, although the examinations took place and the degrees were conferred by the trustees as soon after as a quorum of that body could meet. Dr. Witherspoon was a member of the Continental Congress from 1775 to 1782, and along with Richard Stockton and Benjamin Rush, alumni of the college, signed the Declaration of Independence. Nassau Hall was occupied as a barrack and a hospital by both the British and American troops from 1776 to 1781. It still bears the mark of a cannon-ball fired in the battle of Princeton, Jan. 3, 1777. Another ball destroyed the portrait of George II., a present from Gov. Belcher, which hung in the chapel, now a part of the geological museum.

The Continental Congress met in the library in the second story of Nassau Hall in 1783, and the army lay at Rocky Hill, a short distance from Princeton. Congress was present at the celebration of the Fourth of July by the American Whig and Closophic Societies, the two literary societies of the college. Not only the Congress but the ambassadors of France and Holland and Gen. Washington himself were present at the commencement in September, 1783, when Ashbel Green, the valedictorian, afterwards president of the college, paid a handsome compliment in his address to the Father of his Country. The trustees requested Washington to sit for his portrait, to which he consented. It was painted by Charles W. Peale, and is an admirable likeness of Washington as he looked at that time. In the picture is also a portrait of Gen. Mercer, who was mortally wounded at the battle of Princeton, which is represented in the background. The picture occupies the frame which formerly contained the portrait of George II. Washington, through President Witherspoon, presented 50 guineas to the trustees as a "testimony of his respect for the college."

From Nassau Hall the Continental Congress sent forth its Proclamation of Peace and Thanksgiving in 1783, and Washington dated his Farewell Address to the Army at Princeton.

The college had suffered in all respects from the war; its buildings were devastated, its funds impaired, and its numbers reduced. In 1782 there were only 40 students and 11 graduates, the average number of graduates having been only six for the previous five years. By dint of great effort the buildings were repaired and funds were obtained to pay the salaries. Dr. Smith had conducted the college while Dr. Witherspoon was attending Congress, and was the vice-president during the close of his administration, which was the longest and most arduous in the history of the institution. Dr. Witherspoon had done a great work despite the ravages of war, yet at his death, in 1794, the number of the students and the resources of the college were no greater than they had been at the beginning of his administration in 1768, but it was gradually regaining its old position. Under him 454 students were graduated, \$13 under his predecessors.

Dr. Smith now became president, and with such professors as Dr. Walter Minto, a distinguished mathematician, and Dr. John Maclean, who introduced the "new chemistry" into this country, and at that time had few equals in his special branches of study, a career of prosperity seemed to be opening for the institution. But again was the prospect blighted, for on March 6, 1802, Nassau Hall was destroyed by fire. Friends soon rallied around her. Dr. Smith and others visited the Middle and Southern States and succeeded in collecting funds sufficient to rebuild Nassau Hall, and to erect two other buildings for recitation and lecture-rooms, library, and refectory.

In consequence of impaired health Dr. Smith resigned in 1812. His administration was very successful and his influence upon the students remarkable. There was trouble at times, but the number of students increased and about 30 were graduated annually, 534 in the 18 years of his administration.

He was succeeded by the Rev. Dr. Ashbel Green, an active trustee and very prominent in the Presbyterian Church. Some of the old troubles remained and were increased, but they finally disappeared and the prosperity of the college under him is shown by the large increase of students. He did much for their religious instruction, and in 1815 occurred a most remarkable revival of religion. Under his administration 356 students were graduated, about 36 annually.

He resigned in 1822 and was succeeded in 1823 by the Rev. Dr. James Carnahan, an excellent scholar and administrator. From various causes there was a diminution in the number of students in 1828-29, and several of the professors resigned. Prof. John Maclean, a man of remarkable energy and executive ability, alone remained. Chiefly through his efforts and with the hearty co-operation of the president a new faculty of remarkable ability was formed, which gave great reputation to the college. In it were Profs. Henry, Torrey, Vethake, Dod, J. A. and J. W. Alexander, Jaeger, Hart, and S. Alexander. The policy of enlargement proved to be a wise one, the number of students increased and new buildings were added, notably East and West Colleges, Whig and Clio Halls, and finally a new chapel. Dr. Carnahan's administration, beginning inauspiciously, was the longest and most successful in the history of the college hitherto. When he resigned in 1854 the faculty, the number of students and of the college buildings had been doubled, and an endowment had been begun in the form of scholarships.

Rev. Dr. John Maclean, who had been the vice-president for 25 years, was now elected president. He began his administration by at once enlarging the faculty, bringing in such eminent men as Profs. Atwater and Guyot, and promoting the younger men, extending the curriculum, and increasing the endowment. The college again sustained a most serious loss. Nassau Hall was destroyed by fire for the second time, March 10, 1855. The insurance and contributions of friends defrayed one-half of the cost of its restoration, the other half was derived from the income of the college. The original walls still remain, and the noble building still stands almost substantially as of old.

The college contained the largest number of students (317) in its history when the rebellion broke out in 1861. It had always had a large number of students from the South. After the firing upon Fort Sumter 90 students left in a body to return home. No college in the North probably felt the effects of the war more severely than Princeton. Of her alumni and students 150 entered the Union army and a large number of course were found in the Confederate ranks. The number of students was reduced to 221, and the income of the college was greatly diminished. Appeals were made to friends and the result was large contributions from Mr. James Lenox and his sisters, Mr. John I. Blair, Mr. John C. Green, and many others. Dr. Atwater was especially active in obtaining an endowment. Legacies were received from Mr. Silas Holmes,

Dr. John Woodhull, and Prof. George M. Giger, and were promised by others. The college was placed on a firm basis, the salaries were increased, and the number of students in 1867 was 264; in that year it received 117 new students, the largest accession in its history. In the same year the corner-stone of the fine observatory was laid. This building, the gift of Gen. N. Norris Halstead, cost \$50,000. Mr. John C. Green also gave \$100,000, the beginning of his munificence to the college.

After faithful service for 50 years Dr. Maclean determined to resign. The destruction of Nassau Hall and the civil war had been severe blows, but the college was now stronger and more prosperous than ever. Nearly \$500,000 had been received under his administration, a sum larger than the receipts during all the previous history of the college.

As his successor the trustees selected one of the ablest philosophers of the present age. Dr. Witherspoon had been chosen in 1768; the Rev. Dr. James McCosh, another Scotchman, was chosen in 1868. As history thus repeated itself at the end of a century in this election the old régime passed away and a new era began. The new president entered upon his work with the greatest energy, which was crowned with remarkable success in all respects. New friends presented themselves, liberal gifts were made, beautiful and needed buildings were erected, new studies were introduced into the curriculum, and the faculty was much enlarged. Mr. John C. Green founded the School of Science, erected the building, furnished it with apparatus, and endowed its various chairs. He also erected Dickinson Hall and the Chancellor Green Library. After his death the trustees of his estate erected Witherspoon Hall, Edwards Hall, the small observatory, and made other large contributions. Probably \$1,500,000 were thus contributed from this one source.

Mr. William Libbey erected and furnished University Hall at an expense of \$200,000, and gave the E. M. Museum of Geology so admirably arranged by Prof. Arnold Guyot. Messrs. H. G. Marquand and Robert Bonner erected a fine gymnasium. Mr. Marquand also erected a beautiful chapel, costing \$125,000, and from his brother's estate came \$60,000 to found a School of Art, while other friends of the college contributed \$42,000 to erect an art-building destined to receive the splendid ceramic collection of Dr. William C. Prime. Messrs. R. L. and A. Stuart presented the elegant president's house and grounds, and Mrs. R. L. Stuart gave \$154,000 to found the School of Philosophy. Mrs. E. Stevens and the Rev. S. B. Dod endowed the chair of mathematics in memory of their father, and Mr. J. S. Kennedy endowed the chair of Latin. Murray Hall, for the meetings of the Philadelphia Society, a religious society among the students, was a legacy from a young graduate, Hamilton Murray, who perished in the steamship *Ville du Havre*. Fellowships, scholarships, and prizes were founded and numerous other donations were made. At least \$3,000,000 have been contributed to the college under the administration of Dr. McCosh.

Not only was the curriculum of study enlarged, but a wise system of elective studies was introduced, carefully guarded so as not to lower the standard of education. Post-graduate courses leading to higher degrees through examination were introduced, thus contemplating ultimately a university.

The faculty has been enlarged from 16 members to 40, and the number of students, including post-graduates, has more than doubled, rising from 264 to 604.

This has been the most brilliant and successful administration in the history of the college, and after 20 years of arduous service Dr. McCosh has retired with the admiration and gratitude of all the friends and alumni of Princeton.

While the College of New Jersey has never been under ecclesiastical control yet nearly all its trustees and professors have always been Presbyterians, while

"equal liberties and privileges are secured to every denomination of Christians." It has ever been "a seminary of true religion and sound learning." Daily public worship is obligatory, and the Bible and the evidences of Christianity constitute important parts of its curriculum.

The whole number of its graduates is about 6200. Of this number 1250 have become ministers of the gospel, 400 physicians, and a large number entered the legal profession. About 400 have held high civil office and 250 have become professors. Space forbids the enumeration of those who have held conspicuous positions from James Madison, the fourth President of the United States, down through almost every other honorable office in the National and State governments.

At the last commencement of the college, June 20, 1888, under the most auspicious circumstances, the Rev. Dr. Francis L. Patton was inaugurated the twelfth president of the college. (H. C. C.)

NEW LONDON, a city of Connecticut, and half-shire town of New London co., is on the W. bank of the Thames River, three miles above Long Island Sound, in 41° 22' N. lat., and 72° 01' W. long. The harbor, averaging thirty feet deep, is one of the best in the United States. The city is built on a declivity partly occupied by granite rocks. Railroads connect it with New York, 126 miles distant, and there is also daily steamboat communication. The New London Northern Railroad has here a granite wharf, 1125 feet long. The city has a court-house, a granite custom-house, brownstone city-hall, 5 national banks, 2 savings banks, 12 churches, a high-school and other schools, a daily and a weekly newspaper. The manufactures include woollen goods, cotton-gins, agricultural machines, hardware, and sewing-silk. Fruit-canning and cracker-baking are also carried on. The inhabitants were formerly interested in the whale-fishery, and now in the seal and other fisheries. The U. S. navy-yard is on the E. side of the Thames, above the city. Forts Trumbull and Griswold were built for the defence of the city, but are not effective now. New London was settled in 1645, though not so named until 1658. During the revolution many privateers were fitted out here, and Benedict Arnold captured and burnt it in 1781. In the war of 1812 Decatur was long blockaded in this harbor. The vicinity has now become a popular summer resort. The population of New London in 1880 was 10,537.

NEWMAN, EDWARD (1801-1876), an English naturalist, was born at Hampstead, May 13, 1801. He was a member of the Society of Friends, which his ancestors had joined at the time of its rise. He became a printer in London, but his strong love of natural history led him to devote much time to its study. In 1833 he founded the *Entomological Magazine*, which was merged in the *Entomologist* in 1840. He also established the *Zoologist* in 1843, and to other periodicals he was also a frequent contributor on his favorite subjects. Among his works are *History of British Ferns* (1840); *Introduction to the History of Insects* (1841); *Insect-Hunters* (1858); *Birds-nesting* (1861); *Dictionary of British Birds* (1866); *British Moths* (1869); and *British Butterflies* (1871). He died June 12, 1876.

NEWMAN, FRANCIS WILLIAM, an English author, was born at London, June 27, 1805, being a younger brother of Cardinal Newman. Educated at Ealing School and at Worcester College, Oxford, he graduated in 1826 as a double first-class. He was fellow of Balliol until 1830, when he resigned, because unable conscientiously to sign the Thirty-nine Articles for the Master's degree. He had been trained as an Evangelical, but gradually diverging in an opposite direction to that which his brother had taken, he became a rationalist and eventually simply a deist. His change of views is set forth in his *Phases of Faith* (1850), with which may be compared his previous work, *The Soul, its Sor-*

rows and Aspirations (1849), and a later one on *Theism, Doctrinal and Practical* (1858). After leaving Oxford he spent three years in travel in the East, and on his return became classical tutor in Bristol College. He held a similar position in Manchester New College, 1840-46, and was afterwards professor of Latin in University College until 1863. Among his numerous publications are *History of the Hebrew Monarchy* (1847); *Contrasts of Ancient and Modern History* (1847); *Regal Rome* (1852); *English Institutions and their Reform* (1865); *Miscellaneous, Academic and Historical* (1869); *Europe of the Near Future* (1871). He also translated the *Odes of Horace* and the *Iliad* of Homer in unrhymed metre, the choice of which he defended in a subsequent treatise on Homeric translation. Among his philological works are essays on the languages of ancient Italy, a hand-book of modern Arabic, and an English-Arabic dictionary. Other publications were discussions of public events and social questions of the time.

NEWMAN, JOHN HENRY, Cardinal, was born in London, Feb. 21, 1801. The son of a banker, he was educated at Ealing School. His marked religious temperament led him at first to accept the views of the Evangelical school, whose spirituality had been quickened by the Methodist movement. Having entered Trinity College, Oxford, he graduated in 1820, and soon came in contact with Dr. (afterwards Archbishop) Whately, who, as Newman says, "opened my mind and taught me to think and to use my reason." Whately, when made principal of St. Alban's Hall in 1825, showed his esteem for Newman by appointing him vice-principal. But the place was given up in the next year, when he was elected fellow of Oriel College. In 1828 he was made incumbent of the Church of St. Mary the Virgin, at Oxford. Through Hurrell Froude he formed a friendship with Keble, who had published his *Christian Year* in 1827. Having parted from the Evangelicals, Newman turned to the study of the Church Fathers. His first literary work was *The Arians of the Fourth Century* (1833), a history which grew out of a call to write an account of the Council of Niceæ. His health being impaired by the labor, he made a visit to the shores of the Mediterranean, and during his stay in Rome called on Rev. Dr. (afterwards Cardinal) Wiseman. When he returned the Oxford movement had been inaugurated by Keble's sermon on "National Apostasy." Newman at once began the publication of the *Tracts for the Times*, to set forth what he maintained as Anglican doctrine, and to establish its historical basis. In a few months Rev. Dr. E. B. Pusey (see *ENCYCLOPEDIA BRITANNICA*) joined in the new movement, and his ability, learning, and social prominence gave it such a powerful impulse that it received his name. He, as well as others, contributed to the *Tracts*, whose publication extended over seven years, yet Newman remained the chief author and responsible editor. Following Pusey's advice and example, he engaged also in the preparation of more elaborate works, the first of which was *The Prophetic Office of the Church, Viewed Relatively to Romanism and Popular Protestantism* (1836). The Church of England was held to be identical throughout its history and to furnish in modern times the safe *Via Media*. Next appeared his *Essay on Justification* (1837), in which he controverted Luther's fundamental doctrine of justification by faith alone. In his *University Sermons* the Church was exhibited as a divine institution, "the source of all spiritual power and jurisdiction and the channel of all grace." From 1838 to 1841 Newman was also editor of the *British Critic*, a monthly magazine which upheld these views, though not to the exclusion of other topics. In 1838 Bishop Bagot, of Oxford, in his charge made some animadversions on the *Tracts*, whose Romeward tendency was now plain. Newman at once offered to stop them, but was not then required to do so. At last, in 1841, *Tract No. 90* explained the Thirty-nine Articles so as to remove all

opposition to characteristic Roman doctrine. At this definite conclusion a violent outcry arose. The University authorities condemned the *Tract*. Newman refused to withdraw it, but he discontinued the series, and even consented to refrain from defending the *Tracts*, though many bishops now directed charges against them and the movement they represented. An ecclesiastico-political event, however, induced Newman to break his silence. In 1841 the British government joined with the Prussians in establishing a bishopric at Jerusalem. The scheme had originated with Chevalier Bunsen, who hoped that the unity of Protestantism would thereby be exhibited and promoted. Newman protested openly against the countenance thus given to Lutheranism. In September, 1843, finding he could no longer hold an official position in the English Church, he resigned his charge of St. Mary's and retired to Littlemore, where he had formed a kind of convent. Having lost faith in the catholicity of the Church of England, he formally retracted his earlier attacks on the Church of Rome. For two years he and his associates busied themselves with translations from Athanasius and with writing *Lives of the English Saints*. In 1845, as a chart of the direction of his thoughts, he drew up his *Essay on the Development of Doctrine*; but before it was finished he was received into the Roman Catholic Church (October 9). In the following February he left Littlemore, going first to Oscott, and thence to Rome. Here he was ordained priest, and on returning to England, in 1848, he became head of the Oratory of St. Philip Neri, at Birmingham. The Oratory was afterwards transferred to Edgbaston, where a convent, church, and schools were erected. Besides his labors in conducting the affairs of this order, Father Newman was busy in lecturing and preparing works for publication. Among these were his *Sermons to Mixed Congregations* (1849); *Lectures on Difficulties Felt by Anglicans in Submitting to the Catholic Church* (1850); and two religious novels, *Loss and Gain* (1848), and *Callista* (1856). In 1854 Dr. Newman was appointed rector of the newly founded Catholic University of Dublin, in which he delivered several courses of lectures. Though he seemed eminently fitted for this position by his gifts of mind and character, the institution did not achieve the success that was anticipated. After four years, devoted to organizing and conducting the university, he returned to his former work in the Oratory. The Roman Catholic Church in England owes to him a change in its attitude. Among its members he promoted some freedom of opinion, and diminished the alien proclivities which had formerly characterized them. In 1864 Rev. Charles Kingsley provoked a noted controversy by charging Dr. Newman, in common with other Catholics, with depreciating veracity as a virtue of the natural order, in comparison with spiritual virtues. Newman replied, and as the controversy bore a personal aspect, he published the *Apologia pro Vita Sua*, giving a history of his religious opinions. He endeavored to prove a consistency in his career in spite of the changes in his belief. When the heat of conflict had cooled he regained some favor with those from whom he had separated. Eventually Oxford so far forgave the secession of her distinguished son that in December, 1877, he was elected an honorary fellow of Trinity College. Newman was among those who deprecated the promulgation of papal infallibility by the Vatican Council in 1870. When Gladstone, however, five years later made an attack on Vaticanism, Newman contented himself with pointing out the narrow limits within which infallibility was declared to exist. After the accession of Leo XIII. to the papacy, Dr. Newman was raised to the dignity of cardinal-deacon, May 12, 1879. He resides at Edgbaston, near Birmingham, where he conducts a school for the education of sons of the Roman Catholic gentry, and still supervises the affairs of his order.

A uniform edition of Cardinal Newman's works has

been issued, with some annotations indicating the change in his views since their original publication. Besides the works already mentioned, they include *An Essay in Aid of a Grammar of Assent*, a treatise on faith and reason; *Discourses on the Nature and Work of Universities*, and other educational treatises, and many sermons. He is also the author of several admirable poems and hymns, among which is "Lead, Kindly Light." His writings are noted for the beauty of their style and the purity of their English, as well as for their philosophic treatment of all subjects. Never content with the mere aspect of things, he probes their being until he seems at times to unsettle their reality. Yet his genius is able to present the results of his meditations in most attractive forms. Turning his back on modern criticism and progress, he sympathizes deeply with mediæval scholasticism. His circumstances placed him for a time in the van of a religious movement, but his vocation was always rather that of a teacher, influencing individuals, than that of the leader of a movement. The opposition to liberalism which had been strong in Oxford from 1833 to 1845 lost its importance after his withdrawal. Comparatively few followed him into the Roman Catholic Church, and his subsequent influence was limited almost entirely to that church. (J. P. L.)

NEW MEXICO. Prior to the advent of the Atchison, Topeka, and Santa Fé Railroad, in 1879, the Territory of New Mexico was a comparatively unknown region. The laborious journey over the

plains with ox-teams offered few inducements to emigrants or tourists. Although a part of the United States and under control of the government for 30 years it had received but little attention, and its wonderful natural resources were either unknown or neglected. Delays in settling questions touching the ownership of land and in adjusting conflicts between the races served to retard the progress of the Territory.

With the railroad came an army of active, energetic Americans, who peopled the towns and villages, developed mines, attacked the forests, covered the plains with cattle, and proved the amazing fertility of the soil. Their enterprise has impressed the native Mexican and the Indian, and stimulated the older settlers.

The increase in population has, however, been only about 33 per cent., the population of the Territory at present being about 200,000. The delightful climate and the incentives to fortune-seekers in mining, stock-raising, and farming would have brought many more into the Territory had the land questions or the Indian troubles been settled. Within the years 1886-88 all the hostile Indians have been subdued, and under a firm and enlightened management of Indian affairs no serious trouble is to be apprehended. Many questions affecting the rights of peaceable Indians require the attention and action of the government before full justice is done.

The settlement of the land claims is now being considered by Congress, and it is certainly time that definite action should be taken to carry out the terms of the treaty made by our government with Mexico in 1848. Over 10,000,000 acres are claimed under grants from the Spanish government. The vast majority of these claims are for small holdings, and comprise the best land in the Territory, which has been cultivated for hundreds of years.

Under the treaty of Guadalupe-Hidalgo the United States agreed to protect the holders of property, but their title cannot be made perfect until the land is surveyed by authority of the United States, and the



grants thus located and defined confirmed expressly by Congress.

The Pueblo Indians, 12,000 in number, occupy 19 villages, and own nearly 1,000,000 acres of land. They have herds of horses and cattle, flocks of sheep, cultivate large areas, and raise wheat, barley, oats, corn, fruit, and vegetables. They are steadily improving in their manner of living: leaving the villages and settling on their individual farms, introducing modern agricultural implements and adopting the American dress. The Navajoes number 25,000 and occupy over 8,000,000 acres. They are self-sustaining, but depend upon the sale of horses and wool, cultivating but little land. They have not advanced materially in civilization. The Mesclero Apaches number less than 600 and occupy nearly half a million acres of land. They are making commendable progress. The Jicarilla Apaches have in 1888 been located near Amargo, on a reservation embracing 75,000 acres. The tribe has a population of 900, and under suitable control and guidance will become useful members of society.

The Mexican population in the Territory exceeds 100,000. They engage in mining, stock-raising, and farming. The wealthier class are well educated and vie with the progressive Americans in public enterprises. The poorer classes are steadily improving their condition. The opening of markets for their products has increased the raising of vegetables 1000 per cent. in the past five years. This increased income has enabled them to improve their stock, the furniture of their homes, and the quality of their clothing.

Water ditches have been constructed in Laos, Colfax, Lincoln, San Juan, and Mora counties, which have materially increased the area of productive land. Large ditches are contemplated in different parts of the Territory, and if capital for their construction is secured, immense bodies of fertile land will be open to successful occupancy.

The debt of the Territory is about 70 cents per capita, which is less than that of any State or Territory in the Union.

During the years 1884-88 the annual production of gold has increased 200 per cent., and that of silver 30 per cent.; the government has disposed of nearly one million acres of land to settlers, and the area of agricultural products has been increased as follows: corn 3331 acres, wheat 16,649, oats 3889, barley 500, potatoes 600, hay 16,300.

The public school system, owing to the small amount realized from taxes, imperfect administration, and defective laws, is in a backward condition. The mass of the people are, however, awakening to the necessity of popular education, and in a short time will frame their desires in suitable legislative action. During the years 1883-8 at least 10 public school-houses have been built, a few of which are creditable structures. The laws are administered with more rigor, and a larger proportion of the money actually raised is honestly expended. Boarding- and day-schools under private auspices have increased greatly.

The Indian children are now instructed in 1 boarding- and several day-schools under the control of the Interior department of the government; in 2 boarding- and 8 day-schools conducted by orders connected with the Roman Catholic Church; in 1 boarding- and 4 day-schools under the Home Mission Board of the Presbyterian Church; and in 1 boarding-school controlled by the American Missionary Association.

The youths of the Mexican population are cared for in 3 boarding- and 17 day-schools under the Home Mission Board of the Presbyterian Church; in 4 day-schools under the New West Educational Commission; in 1 boarding-school under the Methodist Church, and in several day-schools under the Roman Catholic Church. In some of these the public money pays part of the expense. A school for deaf-mutes has recently been established.

There are several academies and colleges under the

auspices of religious denominations, but the standard is low. They are doing good work, however, and gaining ground every year.

In numbers, wealth, and influence the Roman Catholic Church leads all the religious organizations in the Territory. During the past five years it has displayed commendable activity in erecting fine church edifices and in establishing schools and hospitals. The Jesuits are in strong force, and the Christian Brothers, the Sisters of Loretto, and the Sisters of Charity and other orders are represented. Some of the orders own extensive ranches, gardens, and fruit orchards, and secure a large income by the sale of their products and in the manufacture of fine wines and brandies.

The Presbyterians, the Methodists, the Congregationalists, the Baptists, the Episcopalians, and the Lutherans have churches in nearly every town in the Territory. They have evangelists preaching and working from village to village and from house to house, and are increasing steadily and rapidly.

The only Young Men's Christian Association in the Territory is located at Albuquerque. The Women's Christian Temperance Union has organizations in every large town. A Father Mathew temperance society is also doing good work. Civic societies are represented in Masonry, Odd Fellowship, Good Templars, Knights of Pythias, Grand Army of the Republic, Woman's Relief Corps, American Order United Workmen, Benai Berith, Ancient Order of Hibernians, Catholic Knights of America, and Knights of Labor.

In the larger towns are regular city governments, gas-works, water-works, electric-light-works, street railroads, and telephone exchanges. Seven daily and over twenty newspapers are published in the Territory.

(R. W. D. B.)

NEW ORLEANS, the metropolis of Louisiana, which had by the U. S. census of 1880 a population of 216,190, was estimated by the State Board of Health to have, in 1888, 248,000, of whom 180,000

were white and 68,000 colored. The disproportion of sexes has been steadily increasing for some years; in 1880 the excess of females was 14,318; in 1888 it had grown to 18,623. The race mixture in the population is great, giving the city a very cosmopolitan appearance. Of people of Anglo-American blood there are but 43,124, or about one-sixth of the total; the French and Creoles (descendants of the original French settlers) number 41,720; the Germans and their descendants, 40,346; the Irish, 37,032; Spaniards and Spanish Creoles from Mexico, Cuba, and South America, 6147; Italians, 4226; Jews, 4118; and other white races, mainly Scandinavians, Poles, Hungarians, and Portuguese, 3287. Of the colored or negro population 22,168 are mulattoes or mestizoes, half or more than half white, some of them being seven-eighths white, but classed nevertheless as "negro" or "colored"; and 44,612 are negroes, although a majority of the latter also contain some white or Indian blood. The Indians and half-breeds number 420, and the Chinese, Malays, and other dark races, 800.

The French language, spoken generally by one-third the population ten years ago, is disappearing, although still used by many. German, Spanish, and Italian survive in general use. The "Creole" or African-French spoken by the negroes is now practically extinct.

While the French and Creole influence which formerly dominated the city has latterly perceptibly waned, New Orleans is still largely French in its ideas and customs. The opera is a success as it is nowhere else in America; the public holidays, as Mardi Gras and All Saints' day, when the graves are decorated, are those handed down from the original French settlers, and the social customs and usages are generally of French or Creole origin instead of English or American.

Since the great epidemic of 1878 New Orleans has escaped its former scourge, yellow fever, and has become a far healthier city than formerly. The improve-

ment is largely due to the establishment of an efficient quarantine system, which has exploded the idea, formerly entertained, that yellow fever originated here. The annual death-rate is now 26.45 per thousand, but very unequally distributed, being nearly twice as great among the negroes (39.03 per thousand), who take no sanitary precautions, as among the whites (21.89 per thousand). The Auxiliary Sanitary Association, supported by popular subscriptions, co-operates with the city and health authorities in cleaning the streets and gutters and in caring for the public health.

The diseases carrying off the greatest number of people are consumption, pneumonia, bronchitis, and other diseases of the respiratory organs, which are frequent in winter in consequence of the humidity of the atmosphere; malarial fevers, which, however, prevail mainly in the outskirts of the city, and diseases of the stomach and bowels. On the other hand most zymotic diseases are generally rarer than in other American cities, scarlet fever unfrequent, typhoid fevers very rare, croup seldom, and cholera infantum almost unknown. The summer has, for the past ten years, been the healthiest season of the year, and the worst the beginning of winter when rains are frequent. The most agreeable weather is from the beginning of February to June, when it is dry, clear, cool, and comfortable.

The drainage of the city, which plays an important part in determining its health, is defective, the original plans never having been carried out to completion. Being without sewers, the drainage is all on the surface, the rain water being carried off in open gutters and canals to the rear of the city, where it is pumped over a levee and thence carried to Lake Pontchartrain, while the garbage and sewage are carried to the river in carts and dumped into it. Steps are being taken to improve the drainage by the construction of a new canal running through the centre of the city, and additional drainage machines. Since 1880 the system of flushing the gutters by pumping water from the Mississippi into them has been practiced, and has resulted in keeping them cleaner and improving the public health.

New Orleans, being spread over a large area of territory, 155 square miles, with 450 miles of streets, has paved but a small proportion of them, the rest being "dirt" streets, wholly unpaved. Since 1883 there has been a decided improvement in this respect, 22 miles of pavement having been laid, of which 9 are in asphaltum, 5 in stone, mainly granite, and 8 in iron gravel.

No public buildings of any importance have been latterly erected in New Orleans. The Shakespeare Almshouse, which accommodates 125 paupers, was erected in 1880, on Carondelet street. Additions have been made to the famous Charity Hospital, and an ambulance service established in connection with it. Other late additions to the already numerous charitable institutions of New Orleans are the Touro Infirmary and Hospital and the Asylum of the Little Sisters of the Poor (Catholic), on Prytania street, and the Jewish Widows' and Orphans' Home on St. Charles avenue. The latter institution is established for the benefit of the Jews of all the Southern States.

The educational advantages of New Orleans have improved greatly since 1880. The donation by Mr. Paul Tulane of \$2,000,000 to the University of Louisiana, the name of which was, in his honor, changed to Tulane University, enabled that institution to greatly extend its operations. An industrial school was established in 1883, and a museum in 1885, and a series of free lectures has been since delivered each winter. Including the medical, law, academical, and industrial departments the college will now average 1200 students in attendance each year. The Sophie Newcombe College for Girls, a branch of Tulane College, was established in 1886 with a donation of \$200,000 from a lady of Louisville.

The colored people of New Orleans have the advantage of four colleges: Straight University (Congregational), Leland University (Baptist), New Orleans University (Methodist), and the Southern University, undenominational and supported by the State. All four are open to both sexes and have an average annual attendance of 1250, about equally divided between males and females. The College of the Immaculate Conception (Catholic), with 450 students, is also authorized to grant degrees.

The Howard Memorial Library, with 125,000 volumes, was erected in 1888 by Miss Annie Howard. The only other public libraries are the Louisiana State Library, 30,000 volumes, and the Fisk or Tulane Library, 12,000.

The commerce of New Orleans has undergone important changes in the last ten years with the construction of railroads. Formerly the trade was almost wholly done on the Mississippi, and "the levee," as the river front of the city is called, became the most active commercial point in the world. As late as 1882 the steamboats and barges handled the greater bulk of the receipts from the interior, but since then the railroads have surpassed them, as shown by the following table of value of receipts of produce:

Year (ending Aug. 31).	Receipts by river.	Receipts by rail.	Total value.
1880.....	\$120,006,300	\$59,765,300	\$179,771,600
1881.....	132,278,425	65,499,750	197,758,175
1882.....	97,187,406	62,329,323	159,516,729
1883.....	117,998,950	82,019,95	200,018,645
1884.....	80,390,194	80,878,843	161,269,037
1885.....	72,803,594	90,920,226	163,723,810
1886.....	65,986,453	104,681,456	170,667,909
1887.....	59,326,765	104,901,839	164,228,601
1888.....	61,420,251	107,054,142	168,474,393

There were three trunk railroad lines reaching New Orleans in 1882. A fourth was built that year, a fifth in 1883, and a sixth in 1885. There are in addition two local railroad lines, the New Orleans, Terre-aux-Bœufs, and Gulf, and the New Orleans and East Louisiana Railroad.

The effect of railroads upon the river traffic is seen in the arrival of steamboats and barges:

	Steamboats.	Barges.	River tonnage.
1880.....	2,658	857	2,609,950
1881.....	2,562	838	2,427,439
1882.....	2,413	857	2,331,528
1883.....	2,335	876	2,261,409
1884.....	2,175	835	2,167,858
1885.....	2,162	932	2,260,400
1886.....	1,954	987	2,184,840
1887.....	1,908	1,099	2,211,350

On the other hand the railroads have increased their tonnage steadily, as follows:

	Received.	Shipped.	Total Tons.
1880.....	543,076	455,712	998,788
1881.....	558,261	474,275	1,132,536
1882.....	685,020	555,639	1,240,659
1883.....	884,223	597,510	1,481,733
1884.....	894,371	623,618	1,517,989
1885.....	1,003,185	619,784	1,622,969
1886.....	1,125,809	635,418	1,761,227
1887.....	1,344,430	746,146	2,090,576

While the commerce of New Orleans has changed much in the last ten years, the volume has increased, the loss in foreign imports and the coastwise trade with the Gulf towns being more than compensated for by the improved trade with New York. The following

shows the value and distribution of the entire commerce of the city for 1886.

<i>Ocean Commerce.</i>			
	Foreign.	Coastwise.	Total.
Imports.....	\$8,115,171	\$51,412,628	\$59,527,799
Exports.....	82,560,198	38,264,984	120,825,182
Total	\$90,675,369	\$89,707,612	\$180,382,981

Receipts of Produce from Interior.

	Tons.	Value.
By river.....	2,337,226	\$61,914,534
By rail.....	1,344,430	106,622,320
Total.....	3,681,656	\$168,533,854

Shipments to the Interior.

	Tons.	Value.
By river.....	1,390,538	\$35,826,230
By rail.....	746,146	62,488,920
Total.....	2,136,684	\$98,315,150

Total Trade.

	Tons.	Value.
With interior.....	5,818,340	\$266,849,004
Total ocean trade.....	2,198,575	180,382,981

Grand Total of Trade.

	Tons.	Value.
For 1886	8,016,915	\$447,231,985
For 1887	8,324,372	462,211,178

New Orleans up to 1870 was almost wholly a commercial city, but since then, and particularly since 1880, it has been forced by trade changes more and more to manufactures, in order to find employment for its working classes. From 1870 to 1880 there were 12,000 men employed in handling cotton in the compresses and placing it aboard ship; while in 1888 the number was reduced one-half. On the other hand there has been a large increase in the number of persons engaged in manufactures. The following table gives the manufacturing statistics:

Year.	Estab-lish-ments.	Capital.	No. hands Employed.	Wages paid.	Value of Products.
1870	554	\$5,429,140	4,411	\$1,204,254	\$8,450,439
1880	696	6,430,303	7,841	3,317,777	18,052,596
1888	2,185	21,667,670	23,865	8,242,599	41,508,646

The chief industries are, boots and shoes (products, \$2,227,500), bread and bakery (products, \$1,923,750), clothing (\$4,424,500), machinery (\$1,485,200), beer (\$1,277,210), lumber, etc. (\$1,484,146), cotton-seed oil and fertilizers (\$3,187,100), rice cleaning and polishing (\$2,792,750), sugar refining (\$7,335,000), and tobacco and cigars (\$1,898,500). There were, in 1888, 3840 women engaged in factory work against only 120 in 1880.

With these new factories important changes have come over New Orleans industrially, socially, and otherwise. Many buildings formerly devoted to commerce have been fitted up as factories. The long period, from May to October, formerly known as "the dull season," when the city went to sleep and business was generally suspended, has disappeared, the factories remaining open and in operation throughout the year.

The control of the city debt is in the hands of a "Board of Liquidation," under whose administration it is being reduced at the rate of \$275,000 a year. The bonded and floating debt amounts to \$17,491,546.

The streets, squares, and public buildings of New Orleans are lighted altogether by electricity, the tower system prevailing in the suburbs. For drinking water the inhabitants are dependent almost wholly on cisterns

and rain, the water-works supplying only the muddy water from the Mississippi, which has to be filtered before use. Latterly a dozen or more artesian wells have been sunk in the city limits, and have struck an abundant supply of water, excellent for drinking or manufacturing purposes, at a depth of 1000 feet.

The history of New Orleans since 1880 has been uneventful, the most important item being the International Exposition held there in 1884-1885, and continued during 1885-1886.

This exposition, known as the World's Industrial and Cotton Centennial Exposition, opened in December, 1884. The United States contributed \$1,000,000 towards its expenses, besides \$350,000 to enable the several Federal departments to make displays. The grounds covered 249 acres. The principal buildings were: the Main Building, 1378 by 905 feet, or 33 acres, the Music Hall in its centre having a seating capacity for 13,000 people; the U. S. Building, in which the United States and the several States had their exhibits, 885 by 565 feet; the Art Gallery; Horticultural Hall, wholly of glass; Factory and Mill Building, for the exhibition of machinery; and the Mexican National Building, where the Mexican display was exhibited. All the States and Territories had exhibits, and of foreign powers there were represented Mexico, all the Central American states, Brazil, England, France, Italy, Russia, Germany, China, Japan, Siam, and other countries. Although the amount of space covered and the number of exhibitors were greater than at any previous World's Exhibition, the attendance was not so large, falling short of 3,000,000. (N. W.)

NEWPORT, a city of Kentucky, the county-seat of Campbell co., is on the Ohio River, at the mouth of the Licking River, 1 mile from Cincinnati, on a branch of the Louisville and Nashville Railroad and the Elizabethtown and Big Sandy Railroad. It has a fine courthouse, post-office, and Masonic temple, 5 hotels, 2 national banks, 1 tri-weekly and 3 weekly newspapers, 20 churches, and 5 schools. The industrial establishments comprise large iron-rolling-mills, bolt-works, pipe-foundry, flour-, saw-, and planing-mills, tool- and tile-works. It has gas- and water-works, a paid fire department, and a park. Its property is valued at \$7,000,000, its public debt is \$1,042,000, and the yearly expenses are \$143,000. It is connected with Covington by a suspension bridge over the Licking River, and with Cincinnati by a railroad bridge with roadways and footways (see BRIDGES, fig. 40). There is also a steam ferry to Cincinnati, and a line of street cars to Covington. Newport, settled in 1791, had in 1880 a population of 15,693.

NEWPORT, one of the capitals of the State of Rhode Island, is on the west shore of See Vol. XVII. Rhode Island, in Narragansett Bay, 5 p. 406 (p. 416 miles from the ocean and 22 miles south of Providence. It has a spacious and commodious harbor, which is defended by Fort Adams, 1½ miles from the city. The U. S. torpedo station is on an island in the harbor. The city contains a state house, U. S. custom house, city hall, 2 libraries, 5 national, 3 State, and 3 savings banks, 15 churches, a high school and other schools, 1 daily and 2 weekly newspapers. The industrial works comprise a brass foundry, 2 cotton-mills, and lead-works. Newport has daily steamboat communication with New York and Providence. It is now chiefly noted as a summer resort, the whole southern part of the island being occupied with hotels and villas. The beach is one of the finest in the United States for bathing and for promenades. Bellevue avenue and Ocean drive are noted for their fine equipages during the summer season. Newport was settled in 1638 by William Coddington, who had separated from Roger Williams' colony. Before the American Revolution the town had become noted for its commercial enterprise. The Redwood Library and several of the public buildings belong to this period. During the revolutionary war the island was occupied

by 8000 British and Hessian troops, who inflicted great injury on the town. The commerce then transferred to New York was never regained. But the excellence of the beach and harbor has made Newport a famous summer resort.

NEW TESTAMENT. This name is applied to the twenty-seven books, originally written in Greek, which are recognized as authoritative among Christians. The term is derived from *Testamentum*, the Latin equivalent for the Greek *διαθήκη*, which usually means "covenant," a more appropriate and significant title. But usage will not now permit an alteration of the name. The articles on the BIBLE in the *ENCYCLOPÆDIA BRITANNICA* and in this SUPPLEMENT treat with much fulness of the main questions respecting the New Testament. The articles on the GOSPELS and on the respective Epistles deal with the special topics connected with the separate books. But a supplementary article is necessary: (1) There has been some addition to our knowledge of the literature of the earlier Christian centuries since the article BIBLE was prepared for the *BRITANNICA*; (2) The treatment in that article suggests doubts to an unnecessary extent; (3) The several books having been discussed by different authors representing a variety of opinion, there is a lack of unity in the other articles referred to. The point of view in the later volumes of the *BRITANNICA* is more rationalistic than that taken by the authors who write on the New Testament books in the earlier volumes.

The topics properly belonging to this article are three: I. The origin of the New Testament books. II. The preservation of this literature. III. The collection of it as a body of writings claiming authority among Christians. These topics are named respectively: Higher criticism of the New Testament; Textual criticism of the New Testament; Canon of the New Testament. The last has been adequately treated in the articles CANON in the *BRITANNICA* and this SUPPLEMENT. It will only be necessary to discuss the first and second.

I. *The Origin of the New Testament Books.*—(1) After protracted discussion, it seems more positively proven than ever before, since the question has been formally raised, that all of the books were written in the first century, between A. D. 53 and 97, that each one is the work of its reputed author (the case of the anonymous Epistle to the Hebrews being an isolated one), that the historical books are trustworthy histories, and that each presents characteristics distinguishing it from all other literature outside this collection, and that taken together the collection forms the authoritative rule of faith for believers in Jesus Christ. The Old Testament writings also constitute a part of this rule of faith, but the fuller and complete revelation is made in the New Testament. The unique character and authority of these writings is due to inspiration, which our Lord expressly attributed to the Old Testament, and which becomes all the more necessary in connection with the records which present to us Jesus Christ himself, since he says of the Old Testament Scriptures, "These are they which bear witness of me" (John v. 39).

2. The earliest books written were six of the Epistles of Paul, namely, 1 and 2 Thessalonians, Galatians, 1 and 2 Corinthians, and Romans (A. D. 53-58). The four last named are "undoubted," no critic, however destructive in his theories, has denied that they were written by the apostle, and near the date given above. It follows, therefore, that in A. D. 58 the belief in Jesus Christ was widely extended throughout the Roman Empire; that the personal object of this widely extended faith was held to be a historical person who had lived and taught in Judea a short time before. It was also held that he had been put to death and risen from the dead on the third day, sending down the Holy Spirit to work spiritual life in those who trusted in him. These are the facts assumed throughout in the

"undoubted" Pauline epistles. We have other literature bearing the name of Paul, other letters purporting to come from other apostles, and five books of a historical character, telling the story of this same Jesus Christ whom Paul preached, one of them narrating the early efforts of the preachers. The question then arises: Are these books what they purport to be? or can we account for them as forgeries or as later "manipulations" of earlier (and truer) documents? The latter view is suggested again and again in the *BRITANNICA*; the former has all the positive evidence to support it. Moreover, when the leading Pauline epistles have been accepted, the rejection of the other New Testament writings cannot be readily justified. (1) If any books, the Gospels for example, are objected to, because they contain statements that imply the exercise of supernatural power by Jesus Christ and his apostles, then the Pauline epistles are open to the same objection. But these epistles cannot be denied; hence a book is not necessarily spurious or "manipulated" if it narrates miracles. Yet many of the historical-critical school argue for the later origin of the Gospels on the assumption just stated. (2) Since the undoubted Pauline epistles prove the existence of a widespread belief in Jesus Christ as early as A. D. 58, it is exceedingly probable that other Christian literature would soon be penned. The belief in Christ was of such a character that it would be impossible to leave the story unrecorded. (3) The only records that have come down with any claim to historical accuracy are those included in the New Testament. In fact there is no proof that any books were written in the first century, other than the four canonical Gospels, that attempted to narrate the history of Jesus Christ. It has often been assumed and asserted that many such Gospels existed, but there is no proof of it. Those who believed in Jesus Christ as Paul did would desire some succinct and truthful records, and when such records were made they would be carefully preserved. Luke, it is true, refers to "many" who had made attempts to write on this subject (i. 1), but his language does not imply that these writings were full histories. He rather suggests that they were unsatisfactory. At all events we have no material of any consequence outside the canonical New Testament respecting the history of Jesus Christ, and no positive evidence exists that any full accounts were written at the same time with our canonical Gospels. It seems certain that some Gospel histories would be written, since the belief in Jesus Christ was so widespread. From the earliest times these four canonical Gospels have been accepted as veritable histories of the person in whom Christians believed. (See below.)

3. The twenty-seven books constituting the New Testament were all written in the first century, between A. D. 53 and 97. The minor details of date and order are open to doubt; but the repeated attempts to prove that some of the books were written in the second century have utterly failed. The evidence in favor of the earlier date, always strong, has been augmented during this generation. The probable chronological order of the books is as follows:

A. D. 53-58: Pauline Epistles, first group (1 and 2 Thessalonians, Galatians, 1 and 2 Corinthians, Romans).

A. D. 61-64: Pauline Epistles, second group (Colossians, Ephesians, Philemon, Philippians).

A. D. 60-70: Matthew, Mark, Luke, Acts, James, 1 Peter.

Uncertain date, but before A. D. 67: 1 Timothy, Titus, 2 Timothy, Hebrews, 2 Peter, Jude.

Toward the close of the century: Gospel of John, Epistles of John and Revelation (an earlier date for the last is assigned by many).

The points open to discussion respecting the time of composition are treated of in the articles upon the several books. The genuineness of the epistles may be accepted as established, since the most serious ob-

jections raised against the Pastoral epistles and 2 Peter have been repeatedly answered. (See articles PASTORAL EPISTLES and PETER.) The important questions respecting the Apocalypse are fully discussed in the article REVELATION. But the most persistent attacks have been made upon the genuineness of the four Gospels. While Dr. E. A. Abbott, in the BRITANNICA, has given an elaborate statement of many of the questions respecting the Gospels, the positions taken are far from satisfactory, and the evidence presented is not convincing. It is, therefore, necessary to discuss more fully the origin of the Gospels.

4. The four canonical Gospels are all of them genuine, that is, the work of their reputed authors. Despite the common matter found in three of them, these three (Matthew, Mark, and Luke) are in all probability independent of each other (in a literary sense), the common matter being derived from the substance of the oral preaching of the apostles and early disciples. The positions of Dr. Abbott, to which most serious exceptions must be taken, are: (1) his theory of the origin of the synoptic Gospels; (2) his denial of the genuineness of the Fourth Gospel.

5. The *origin and relation* of the synoptic Gospels. The problem has been discussed most vigorously, but is still far from a satisfactory solution on any theory other than that of independence. It still seems most probable (as Canon Westcott, Godet, and others hold) that no one of these three writers borrowed matter from the Gospel written by either of the others. It is not probable that any one of them ever saw the work of the other. There is no internal evidence of any one of them having written (or modified) his narrative to supplement, correct, or adapt the work of another. Nor can the theory of a common document as the basis of all three be established. Dr. Abbott "passes his pen through all that is not common to the three synoptists, and offers us the residuum as the closest approximation we possess to the original narrative from which each of the three was derived" (Dod's *Introd. to the New Testament*). The same theory has been most beautifully illustrated in a printed edition of the Greek Testament, called *Synopticon*, of which Dr. Abbott is one of the editors. But a careful study, with this convenient help, does not convince the writer that we are thus brought nearer to the original source of the narrative. It is true, and has long been remarked, that the Gospel of Mark bears greater evidence of originality than either of the others, and that were there an original Gospel as a common basis of all three, Mark most nearly represents that original. But further than this we can scarcely go, nor is there anything to be gained by going further. Either our canonical Gospels are true or they are full of later additions. As a literary problem we may discuss the literary origin of the different forms of the same story as recorded by two or more of the evangelists. But the unfairness of most of the critics consists in this, that they suggest and imply what they will not assert. They claim that the discussion is a purely literary one, and presently we discover that it is a historical one. The truthfulness of the various narratives is assailed under cover of a literary problem. The Tübingen school was entirely honest in its attitude. It attempted to solve the literary problem by a certain historical theory (*Tendenz-theorie*), to the effect that there were two opposing parties in the early Christian Church, and that the Gospels arose in the second century as the result of these conflicts and attendant compromises. This theory has been disproved; all more recently discovered evidence controverts it, though much deference is paid to it in some of the articles in the BRITANNICA. The present "critical" school does not accept this theory, but seeks to discover the original historical basis of the Gospels. Sometimes this is done without denying the truthfulness of our Gospels, but oftener it is implied that all the matter which cannot be traced to some assumed "original source" is less trustworthy. Against

the entire method it may be urged that no positive results have yet been firmly established, despite the immense amount of labor bestowed upon the problem. Twenty distinct theories could be cited, each differing from the others, and some of them destructive of each other. For example, Meyer and Weiss, two of the most distinguished German commentators, agreeing in many respects, differ in regard to the relation of the synoptic Gospels, Meyer holding Mark to be the earlier, Weiss stoutly contending for Matthew, while they differ as to the "original source" lying back of the synoptists. Weiss accepts a large amount of narrative matter in the "apostolic source" which he assumes to lie back of the Gospel of Matthew. To this Meyer responds in substance: "If there is so much narrative, why not accept the Gospel of Matthew itself as the original source?" Indeed the attempt to separate the "discourses" from the history can only prove a sorry failure; many of the most striking sayings derive their pertinence from the occasion (often a miracle) that suggested them. The height of absurdity was reached in this discussion by Ewald, who, in his analysis, finds ten distinct books, seven of them going to make up in differing combinations the three synoptical Gospels. It is, of course, an interesting literary problem, and in discussing it there is room for great ingenuity. But thus far one man's guess has proved as good as another's.

In order to find room for all this literary development it is necessary to place the date of writing at a time which, on other grounds, seems too late. The three synoptical Gospels bear every mark of having been written before the destruction of Jerusalem (A. D. 70). Dr. Abbott makes a labored plea for a later date in the case of Luke. But the only argument of any special force is that from Luke's specific references to the details of the destruction of Jerusalem (chaps. xix. 43; xxi. 24). It is urged that such plain statements could have been written only after the event. That amounts to this position: because Luke represents Jesus Christ as making a distinct prediction which was speedily fulfilled, Jesus Christ did not make the prediction, but Luke invented it and put it in his mouth. Unfortunately Dr. Abbott is not alone in arguing upon such an assumption. But it is clear from the Book of Acts that the Gospel of Luke was written as "a former treatise" (Acts i. 1). The narrative in the Book of the Acts closes with A. D. 63. It is natural to infer that the date of the second treatise was near that time. Furthermore, Luke was with Paul at Cæsarea during the years 59, 60. What more natural than to suppose that during this time he collected the material for his Gospel, since he refers to his labors in discovering the facts (Luke i. 3)? It is exceedingly improbable that ten years would elapse before he published these facts. It is therefore likely that all three Gospels had been penned by the close of A. D. 63. There is not sufficient time for editing and manipulating "original sources" in the interval between the death of Christ and this date.

The recently discovered evidence, moreover, confirms the early date of the Gospels. Not only is it now established that the Epistle of Barnabas expressly cites the Gospel of Matthew, but the *Teaching of the Twelve Apostles* again and again uses the language of that Gospel, and in some cases seems plainly to refer to that of Luke. This document, lost for many centuries, was written about A. D. 120. It was discovered in 1873, but not published until 1883. In the same collection of MSS. the entire Homily (miscalled 2 Clement) was discovered. In this sermon the preacher refers to the New Testament Scriptures as τὰ λόγια τοῦ Θεοῦ (chap. xiv.). Now the date of this homily is between A. D. 120 and 140. By that time clearly the Gospels were read in Christian assemblies as Sacred Scriptures. Papias has referred to Matthew as writing "Logia," and it has been stoutly affirmed by some critics that this term can only mean "discourses," and

cannot mean a gospel like ours. Yet the same term is used by a contemporary of Papias in the technical sense of Scripture, as indeed was done by Paul in Rom. iii. 2. We may add that these recent discoveries of Christian literature written in the early part of the second century go far to establish the impossibility of any author in that age having the ability to write (or even edit) our Gospels. All this makes against the theories which find in the synoptic Gospels matter added or modified by later hands using a common original source.

The results of textual criticism come in as corroborative evidence (see below, II.). We now know from most abundant manuscript authority just how much of alteration has taken place in the New Testament text during eighteen centuries. In the Gospels the various readings are most numerous. But all the variations in all the Gospels taken together do not constitute a sufficient amount of variation to account for the differences between the synoptic narratives in a single chapter. When once the Christians accepted these books they were carefully preserved from modification. How unlikely it is that there was some older Gospel (truer than these, as is assumed) which, instead of being carefully preserved, was edited by various hands and the results palmed on the Christian people as the work of the reputed authors? If for eighteen centuries believers have been careful of the Gospel records, the earliest believers would not be less so in the care of an original Gospel. Hence it is not probable that any original Gospel other than ours ever existed and obtained currency. The early age of the synoptic Gospels is more fully established now than ever before, and the earlier the date of composition the more probable is their literary independence. The arguments against their truthfulness from alleged discrepancies need scarcely be considered here. No greater divergence in testimony exists than might be expected from the different purpose, point of view, and emphasis. Absolute contradictions cannot be said to exist. It is true there remains an unsolved difficulty in regard to the original language of the Gospel of Matthew. The constant early tradition states that it was first written in Hebrew; but only the present Greek Gospel is cited by the same witnesses, and there are marks of its being an original Greek work. The tendency now is to accept our Gospel as the Greek original, but the theory of a Hebrew original translated by Matthew himself would account for the two classes of facts indicated above. Such a theory is far more probable than most of the solutions of the synoptic problem.

6. *The Genuineness of the Fourth Gospel.*—Dr. Abbot doubts or denies that the apostle John was the author of the Gospel bearing his name. (In the article REVELATION will be found a discussion of the objections arising from the differences of style and language between this Gospel and the Apocalypse.) To deny the genuineness of this Gospel is a much more serious matter than to hold certain literary and critical views of the origin of the synoptic Gospels. Those Gospels do not assert their authors and authority; the Fourth Gospel expressly claims to be written by the beloved disciple, and frequently makes statements and explanations with apostolic authority. The alternative here, at all events, is: Is this book genuine or is it a forgery? As Dr. Abbot has stated very fully his objections to the Johannine authorship, the other side must now be given.

A. *External Evidence.*—The testimony is not only unbroken, but more abundant and positive than in the case of the synoptic Gospels. Nor are we without recent additions to this evidence. It was long known that Tatian (died A. D. 172) wrote a *Harmony of Four Gospels (Diatessaron)* between 153 and 170. But as the work was lost, it could not be proven that he used the Gospel of John. Recently the discovery of an Armenian translation of a commentary upon it by

Ephraim the Syrian makes it certain that he used our four Gospels. (The Armenian work was translated into Latin in 1841, but escaped general notice until 1876. Since that date the text of Tatian's *Harmony* has been largely reconstructed from it.) Shortly after the middle of the second century the four Gospels were so widely known and accepted by Christians that a harmony of the four narratives was prepared. This proves that all four had been received for some time. Indeed, there are no indications of any serious objections to the Johannine authorship of the Fourth Gospel in the second century. The Alogi were a handful of eccentric persons with extravagant views about the New Testament, and their doubts have no weight whatever. The testimony of Irenæus (Bishop of Lyons, A. D. 178) is specific and ample as to the Johannine authorship and general acceptance. It would seem probable, therefore, that a book accepted as the work of the apostle John by Tatian (between 150 and 170) would be known to Justin Martyr, who was the teacher of Tatian. The interval of time between the *Apology* of Justin (A. D. 138-147) and the *Diatessaron* of Tatian is not long. At the date of the latter the Gospel of John was everywhere accepted. How could a forgery have gained currency between the date of Justin's *Apology* and the appearance of the *Diatessaron*? Dr. E. A. Abbott, in the *BRITANNICA*, makes a full and plausible argument against Justin's knowledge and use of the Gospel of John. But Prof. Ezra Abbot, the distinguished Unitarian Biblical scholar in Harvard University, published as his last work a small volume on *The Authorship of the Fourth Gospel: External Evidences*, which fully, fairly, and with an affluence of citation, answers every objection raised in the *BRITANNICA*. The argument cannot be given in detail, but as this most valuable and learned monograph is not properly known, it is well to cite in full the summing up of the case respecting Justin Martyr's knowledge of this Gospel. "We find," Prof. Ezra Abbot says, "(1) That the general reception of our four Gospels as sacred books throughout the Christian world in the time of Irenæus makes it almost certain that the 'Memoirs called Gospels, composed by Apostles and their companions,' which were used by his early contemporary, Justin Martyr, and were read in the Christian churches of his day as the authoritative records of Christ's life and teaching, were the same books; (2) That this presumption is confirmed by the actual use which Justin made of all our Gospels, though he has mainly followed, as was natural, the Gospel of Matthew, and his *direct* citations from the Gospel of John, and references to it, are few; (3) That it is still further strengthened, in respect to the Gospel of John, by the evidence of its use between the time of Justin and that of Irenæus, both by the Catholic Christians and the Gnostics, and especially by its inclusion in Tatian's *Diatessaron*; (4) That of the two principal assumptions on which the counter-argument is founded, one [that Justin's description of the manner of the teaching of Jesus shows that he did not know the Fourth Gospel] is demonstrably false, and the other [that if he used it at all he would have used it more] baseless; and (5) That the particular objections to the view that Justin included the Gospel of John in his 'Memoirs' are of very little weight. We are authorized then, I believe, to regard it in the highest degree probable, if not morally certain, that in the time of Justin Martyr the Fourth Gospel was generally received as the work of the apostle John" (*Authorship, etc.*, pp. 79, 80). The learning of Ezra Abbot is evinced in his treatment of this question; his candor is transparent, and of theological bias there could be no suspicion in his case.

But it can be claimed that the Gnostic sects flourishing during the lifetime of Justin Martyr accepted and used the Fourth Gospel as the work of the apostle John. The evidence from Hippolytus seems quite clear that Basilides and Valentinus before the middle

of the second century used this Gospel without question. As it was an armory of attack for their orthodox opponents, the fact that they did not deny its authority seems conclusive against every attempt to prove a later origin than the apostolic age. Were it forged or altered to sustain orthodoxy, these heretics would have so asserted. Furthermore the development of heresies (or even differences of opinion) requires time. Since these Gnostics used the Gospel of John without question as well as their opponents, at no time during the development of this difference could a spurious Gospel have been palmed off as written by John. In view of this it is impossible to date the Gospel in the second century. Those who will not accept it as genuine still claim as late a date as A. D. 110 or 115, but with no positive evidence to support this view, and without being able to find any one who could have written such a work. But suppose it were written (that is, forged) in A. D. 115. There were probably thousands of Christians then living who had known the apostle John. How could a forgery at that time have obtained universal acceptance? In Ephesus, a great commercial city, where John had been living, some one would have detected the fraud. Only when we can believe that the Christians of that age were as credulous in their faith as the modern opponents of this Gospel are credulous in their unbelief, can we regard such a date for the Gospel as in the slightest degree probable. Prof. Ezra Abbot calls attention to some of the closing words of the Fourth Gospel ("and we know that his testimony is true") as containing an "attestation to the truth and genuineness of the Gospel." Such an attestation would never have been appended to a forged document.

B. Internal Evidence.—Here we are confronted even more directly with the alternative, truth or fraud. The moral tone of the Gospel is such that a forgery seems a psychological monstrosity. Yet the author so describes himself, without any immodesty or self-assertion, as to convey everywhere the impression that he was "the beloved disciple." The objections raised from the assumed contradictions to the synoptic narratives have been repeatedly answered.

The positive internal evidence is derived (1) from the style, which points to the author as a Hebrew Jew (not a Hellenist) who was yet familiar with the Greek language from long residence in a city where that language was spoken. The simple structure also points to an aged man. There is no one who so well suits these indications as the apostle John.

(2) That the author had lived in Palestine is also evident from many local allusions, and from the familiarity with Jewish usages. It has been objected (by Matthew Arnold among others) that he refers to these matters as a foreigner might do. But the Gospel, it is claimed by all, was written after the destruction of Jerusalem, when Jewish usage was comparatively unknown in Asia Minor, and explanation was required. The knowledge of Jewish affairs in the time of Christ, evinced by the author, is strikingly minute.

(3) The evidence that the author was an eye-witness of many of the events he records is obvious even to a careless reader of the Gospel. He refers to persons, what each one said, as the synoptists do not. Well-nigh every chapter contains some mark that suggests the presence of the author. Not only so, but he speaks of himself as present, claims especially to tell what he has seen. "Here we are driven to the alternative: either the writer was a true witness of what he relates, or he was a false witness who wrote down a deliberate lie" (Schaff).

(4) The writer intimates again and again that he was one of the Twelve. He tells what the others said, naming one and another. He modestly conceals his own name, but in so doing all the more conclusively reveals his own person. It can scarcely be denied that the author meant to convey the impression that he was the apostle John. Moreover, the explanations he in-

serts, the tone of authority he sometimes assumes, go to show that the author knew himself to be (without proving it) one who was recognized as entitled to speak in this way. The probability that any one could have thus successfully personated the apostle in a literary forgery is very small; that any one in the first quarter of the second century could have done it would seem impossible save to those who have prejudged the case.

The argument from internal evidence may be closed by a citation from Pres. T. W. Dwight (Godet's *Commentary on the Gospel of John*, Amer. ed., pp. 511, 512): "There is no doubt that the author of this Gospel penetrated in his thought into the centre of the Christian system, as it has been understood by the church. The question of the authorship becomes, therefore, one of gravest importance. If the author was that most intimate disciple of Jesus of whom the book speaks so frequently, he gained his conception of Christ and the new faith from the Lord himself, and could not be mistaken. His book is the flower and consummation of the apostolic thought. It is in the truest and highest sense inspired of God. The attempt to deny the system is a hopeless one, so soon as this Gospel is established on a firm foundation. In view of this fact, it may well seem divinely ordered that the book should stand in the world as it has ever done, bearing within itself its own evidence. The writer of it, in addressing the readers for whom his first Epistle was intended, says that he writes that which he has seen and heard, in order that they may have fellowship, as he himself has, with the Father and with his Son Jesus Christ. It is a wonderful fact in the history of the centuries which have passed since he wrote, that those who have been persuaded by his story to believe and who have been conscious, as the result of their faith, that they had fellowship with God, have had an abiding confidence that he told of what he had heard and seen, and that it is those who have rejected the doctrine and the peculiar life, who have questioned the reality of the author's experience as the disciple whom Jesus loved. The past may give us confidence in the future; and we may safely predict that, until the inner life of the author ceases to bear this witness, he and his Gospel will be among the unshaken pillars of the church."

7. The Acts of the Apostles.—That this book was written by Luke, the companion of Paul, is suggested by internal evidence, and has been supported by external evidence from the earliest times. But the Tübingen school assumed to find in it irreconcilable differences with the four Epistles of Paul they accepted as genuine. This was necessary for their theory. But many of their arguments rest upon false exegesis, and few scholars now accept their extreme conclusions.

Still in the *BRITANNICA* there are suggestions made casting doubt upon the historical verity of the narrative. Here, as in the case of the Gospels, a "patch-work" theory of the origin of the book has been accepted by many critics. Some parts, *e. g.*, the sections where "we" is used, were written by Luke, but the book has been edited by a later hand in the second century. It contains a basis of truth, but is not all of it historical.

But the clumsiness of this theory is apparent even to Renan. If the integrity of the book be accepted, the whole of it must be ascribed to Luke. The date would seem to be not much later than A. D. 63, at which time the narrative ends, somewhat abruptly. The positive proofs of the authenticity of the entire narrative are very strong. No other historical book of the New Testament touches upon so many points where verification from other sources is possible. The titles applied to magistrates in the different cities, the topographical allusions, the hints of local usage, the itineraries—all these in hundreds of instances have been proven accurate, even when imperfect knowledge had previously indicated that the author had made a mistake. (In Schaff's *History of the Christian Church*,

Vol. I., pp. 732-736, fourteen of these confirmatory facts are discussed.)

Objections have been raised to the reports of the discourses recorded in this book. But a careful comparison of the speeches of Peter and Paul respectively with the writing of these apostles confirms the accuracy of the author of the Acts. Indeed the investigations have gone further: it has been shown that the different discourses attributed to Paul give evidence in style of the presence and absence of Luke, of the circumstances connected with their delivery as stated in the Acts. Objection has been made to the substance of these discourses, as indicating a "purpose" in the author who records them. This is an echo of the Tübingen theory. The entire narrative has such marks of candor that it seems psychologically impossible for the author to have distorted the language of the apostles to serve his own theological or literary purpose. "Examine and compare the secular historians from Herodotus to Macaulay, and the church historians from Eusebius to Neander, and Luke need not fear a comparison. No history of thirty years has ever been written so truthful and impartial, so important and interesting, so healthy in tone and hopeful in spirit, so aggressive and yet so genial, so cheering and inspiring, so replete with lessons of wisdom and encouragement for work in spreading the gospel of truth and peace, and yet withal so simple and modest, as the Acts of the Apostles. It is the best as well as the first manual of church history" (Schaff, *ibid.*, p. 739).

8. *Comparison with the Literature of the sub-Apostolic Age.*—Accepting as proven the genuineness of the twenty-seven books constituting the New Testament, we may call attention to the facts respecting the Christian literature of the succeeding age. The additions to this literature recently discovered have already been referred to. One and all of the Christian writings of the generation succeeding the apostles fall immeasurably below the New Testament literature. That some of the former were highly esteemed for a time in the Christian Church is well known, but they were never exalted to a level with the New Testament by any formal act or by general consent. So soon as controversy arose and the question of authoritative writings was considered, the canon of the New Testament was formed, and with little difficulty (see article CANON). But the fact on which emphasis must be put is this: that there is an obvious descent from the New Testament to the apostolic fathers, that no one in the first half of the second century appears as an author capable of writing any of the books of the New Testament. While each age of the church rightly reviews the whole question of the origin and authority of the New Testament books, added to the historical evidence there is this obvious difference in the literature to give internal attestation. The proof of the existence of the sun is its shining; the New Testament shines by its own light.

II. *The Preservation of the New Testament Text.*—This study is called "textual criticism," in distinction from the "higher criticism." Both are necessary, but they differ in their aim. The higher criticism discusses the origin of the books, the lower (or textual) criticism seeks only to discover a pure and entire text. Hence it deals only with positive evidence, allows no conjectural emendation, and never impugns the authority of a book, questioning only whether the very words have been preserved uncorrupted. As is well known the sources for determining the exact words of the New Testament are vastly better than in the case of any other book. The very extent of our authorities has multiplied minor variations; yet despite all this, the number of various readings is not proportionately so great as in the works of some classical authors of which few manuscripts exist.

The subject of New Testament textual criticism has been treated by Prof. W. Robertson Smith in the BRITANNICA (article BIBLE); but during the years

since that volume was published there has been a remarkable advance in this science. A few old manuscripts have been discovered (notably *Codex Rossanensis*), but the main progress has been in the recognition of correct principles. The discovery of Aleph by Tischendorf and the publication of B (*Vaticanus*) at Rome virtually revolutionized the entire estimate of manuscript authority. When Prof. W. Robertson Smith wrote, the effect of the use of these two manuscripts had not yet been fully manifest. The publication of the Greek Testament of Westcott and Hort and of the Revised English version of the New Testament (in 1881) mark the great advance. We may add that the *Prolegomena* to Tischendorf's Greek Testament have been edited by Prof. C. R. Gregory (now of Leipzig), the first part appearing in 1884. The Revised version conveys to the general reader the results obtained by the textual critics who have published the learned works just named. The principles and results may be briefly stated.

The Principles of Textual Criticism.—It has long been seen that the ancient authorities represent three groups of evidence: one from Alexandria, the second from the Western Church, and the third coming to us from Constantinople. The first seems to be the purest, the second is full of minor variations (in both Greek and Latin), but very valuable as indicating the origin of various readings. The third (called Byzantine, Constantinopolitan, and, in its older forms, Antiochian and Syrian) seems to have undergone more changes, owing to the attempts at harmonizing, smoothing, and polishing the text. The modern school of textual critics agree in giving more weight to the oldest manuscripts, and also in attempting a classification (or genealogy) of the various forms of the text. On this theory of evidence the immense number of later cursive manuscripts loses its weight. It is further agreed that each variation must be separately discussed, and that only when the authorities are nearly of the same weight should internal grounds be considered.

But Westcott and Hort have developed a fuller theory. They accept *four* groups, one named by them "neutral," representing the earliest form of transcribed text accessible to us. The chief authority in this group they claim is the *Codex Vaticanus* (B). They also accept the view that the Syrian text is later than the others, having undergone a revision in the third century. Hence that it is of little value when not agreeing with any of the others, but very useful in enabling us to choose between variations in the pre-Syrian texts. Practically their theory makes B outweigh all other authorities, and their Greek Testament rarely omits to notice the readings of B, even when they are not placed in the text. The views of Westcott and Hort have been strongly opposed, and the two weak points (a neutral group, and a Syrian revision) have been objected to by those who accept in the main the practical results of their labors. On the other hand Tischendorf, while presenting a text nearly agreeing with Westcott and Hort, is too apt to follow Aleph (his own discovery), and in the Gospels to adopt readings that differ from the parallel passages. Yet Tregelles, Tischendorf, Westcott and Hort, with most modern scholars, are in substantial agreement as to the defects of the received text and the weight of the older authorities.

The Revised Version does not follow any one of these editors. The questions of text were discussed in both the English and American companies, only so far as they could affect the English rendering. No attempt was made to revise the Greek text as such; but the Revised New Testament, as may readily be seen, accepts in the main the judgment of the textual critics named above. It is probably nearer to Tregelles than to Tischendorf, and nearer to Westcott and Hort, though often dissenting from the latter. More remains to be done; yet there can be no question

that there is now greater agreement among experts in this department than ever before. It is quite significant that recent German scholars have recognized the great value of the text of Westcott and Hort. The so-called conservative school of critics, who uphold the Syrian text, often urging that it has been endeared to so many generations of Christian people, must necessarily fight a losing battle. The modern textual critics are not attempting to do anything else than to restore the *ipsissima verba* of the word of God.

Conclusion—The great progress in textual criticism, far from weakening our confidence in the New Testament, confirms it. (1) The positive evidence of the care bestowed upon the text and its substantial purity show that we can trust it as we can no other ancient literature. (2) The number of variations has helped, not hindered, the establishment of a correct text on adequate evidence. (3) The spirit in which textual criticism has been conducted is in sharp contrast with the wild theories of the "higher criticism." The former has been investigated in a purely scientific, yet reverent, method. (1) The Christian public has not yet accepted the results as embodied in the Revised New Testament. But this should not be regarded as discouraging. It was several centuries before English Biblical scholars dared to question the accuracy of the so-called Received Text (Stephens, 1550).

A long process of education as to the basis of the correct text will be required for the general Christian public. That the truth will ultimately win we cannot doubt, especially in view of the present movement toward popular study of the Bible. (M. R. N.)

NEWTON, JOHN, engineer and general, was born at Norfolk, Va., Aug. 21, 1823. He graduated at West Point in 1842 and entered the U. S. engineers. He was engaged chiefly in the construction of fortifications on the Atlantic and Gulf coasts until the outbreak of the civil war. In 1861 he was chief engineer of the departments of Pennsylvania and the Shenandoah until August, when he was made brigadier-general of volunteers and commanded the defences of Washington. In McClellan's Peninsular campaign Gen. Newton was engaged at Gaines' Mills and Glendale, and afterwards at South Mountain and Antietam. At Fredericksburg, Dec. 13, 1862, he commanded a division, and in March, 1863, was promoted major-general. During the battle of Chancellorsville he stormed Marye Heights, May 3, 1863. At Gettysburg he succeeded to the command of the First corps, July 2, 1863, which he held until March, 1864, when he was transferred to Gen. Sherman's command. He took part in the Atlanta campaign, and afterwards held commands in Florida until 1866, when on the reduction of the army he returned to the engineer corps with the rank of lieutenant-colonel. He became colonel in 1879 and chief of engineers in 1884. Among the important works conducted by him were the removal of the obstructions at Hell Gate and other points on East River, the improvement of Hudson River, and of the channel between Staten Island and New Jersey (See HELL GATE IMPROVEMENTS). The final explosion at Flood Rock took place Oct. 10, 1885, and thereafter Gen. Newton was engaged in improvements of the channels around New York until his retirement on Aug. 27, 1886. A year later he was appointed commissioner of public works in New York city.

NEW YORK. This State, by its population and wealth, still justifies its claim to the title of the "Empire State." The last p. 450 (p. 462 federal census shows, that having a population of 5,082,871, it surpassed Pennsylvania (the second State) by 799,980, and Ohio (the third State) by 1,881,809. It is entitled to 34 members of the U. S. House of Representatives. Together with Vermont and Connecticut it forms the second judicial circuit of the United States; and it is itself divided into southern, northern, and eastern judicial districts of the same court. There is a U. S.

marshal and a district attorney for each judicial district.

The first governors entered upon their office on July 1st following their election; but since 1823 the date has been Jan. 1. The term of office was two years down to 1879, since which date the term has been three years. The lieutenant-governors have been chosen at the same elections with the governors, and their terms of office have been the same as those of the governors.



Every alternate year the following State officers are elected by the people: comptroller, treasurer, attorney-general, secretary of state, and State engineer and surveyor. The secretary of state keeps the State archives, and is custodian of the great seal of the State, which (by recent enactment, 1883) has been carefully defined.

Finances.—The report of the State treasurer for 1888 showed that there was a balance of \$3,378,540.36 in the treasury, Jan. 1, 1888. The following table shows the receipts and disbursements for the fiscal year ending Oct. 1, 1887:

	Receipts.	Payments.
General fund.....	\$9,526,251.91	\$8,599,886.10
Common school fund.....	298,084.80	254,519.12
College land scrip fund...	21,439.07	3,569,827.49
Literature fund	313,766.32	310,554.51
Military record fund.....	2,881.73	344,023.85
U. S. deposit fund.....	358,727.80	19,327.63
Free school fund.	3,717,749.68	1,574.71
Canal fund.....	3,590,523.80	3,671,735.53
Woman's monument fund.	42.00	
Total.....	\$17,829,467.11	\$16,771,448.98

There was received from the earnings of the State prisons during the year, \$1,111,823.59; State tax, \$5,805,400.78; tax on organization of corporations, \$201,663.99; corporation tax, \$1,239,864.16.

The comptroller valued the investments at the close of the fiscal year as follows: common school fund, \$3,930,657.39; U. S. deposit fund, \$4,017,220.71; literature fund, \$234,201.30; college land scrip fund, \$474,409.12; canal debt sinking fund, \$4,061,188.84. Total, \$12,767,677.36. Recent laws have authorized the investment of the money of various State funds in the public securities of the villages, towns, cities, and counties of this State. The wider range of investments thus sanctioned has made it practicable to secure substantially better rates of interest than could otherwise have been obtained. At the same time the use of these moneys in the discriminating purchase of local securities has inured to the benefit of thriving and solvent cities and villages. For 1888 the State tax is \$9,075,046.08, the rate being 2½ mills, and the valuation \$3,361,128,177, the tax to be devoted as follows: school purposes, \$3,697,240.99; canals, including canal debt, \$2,352,789.73; general purposes, \$3,025,015.36. Total, \$9,075,046.08. The direct school tax for 1887 produced \$3,708,384.69. The total expenditure from the State treasury for educational purposes was \$1,152,874.65. The total expenditure, State and local, for the maintenance of schools was \$14,461,774.94. Setting aside the general fund debt for Indian annuities, the principal of which amounts to but \$122,694.87, the gross State debt upon Sept. 30, 1887, was \$7,444,310, of which sum \$800,000 is the amount outstanding of the debt created to provide for the payment of the Niagara Reservation awards in 1885, which mature at the rate of \$100,000 per annum. The remaining \$6,644,310 is the canal debt, the last of which matures in October, 1893, and which has been reduced during the fiscal year by \$1,660,200. The receipts

from taxes upon corporations have been somewhat reduced by smaller revenues from insurance companies. A new law, imposing a tax of 5 per cent. upon the gross receipts for admission to race-tracks, brings about \$25,000 into the treasury, which amount is disbursed by the State Agricultural Society in the form of prizes for improving the breeds of cattle, sheep, and horses at the various county fairs throughout the State. The interest derived from State funds largely exceeds \$200,000. The prosperity indicated in State affairs and the reduction of the indebtedness to so insignificant a point have not been attained by any sacrifice of substantial interests, or by unduly withholding effort in any direction. On the contrary the past four years comprise a period of peculiar and wise liberality in certain respects. The gross amount appropriated from the general fund during those years for land purchases and for construction of buildings exceeds \$8,500,000. This sum is the more notable as construction appropriations for the new capitol have been less lately than in former years, the amount for the four years in question being \$2,254,000. Of the remainder \$1,500,000 were expended in the purchase of the Niagara Park Reservation. There remain, therefore, \$4,500,000 appropriated in four years to purchase land or for construction for charitable, penal, military, educational and general purposes—canal construction and purchases not being included in this enumeration. Among the more important recent appropriations are: \$300,000 for a new asylum for insane criminals; \$190,000 for the Hudson River State Hospital (popularly known as the Poughkeepsie Asylum); \$190,000 for the asylum just projected at Ogdensburg; \$120,000 to rebuild the female department of the State Industrial School at Rochester; \$300,000 for State Prison repairs; and \$173,000 for additions to the Buffalo Asylum. Expenditures of this sort are used to better advantage than was true twenty or more years ago. Certain charitable institutions then constructed represented an outlay of from \$2000 to \$3500 for each inmate who could be properly accommodated in them. Recently similar institutions and buildings have been projected or erected at a cost of from \$320 to \$800 for each inmate, the provision made in these latter instances being more than equal to that furnished by the earlier institutions or edifices.

Assessment.—Since 1883 the assessment of real estate has increased from \$2,557,218,240 to \$3,025,229,788 in 1887, or \$468,011,548. Since 1883 the assessment of personal estate has increased from \$315,039,085 to \$335,898,389 in 1887, or \$20,859,304. The valuation of taxable property in 1867 was \$1,664,107,725; the gross valuation in 1887 was \$3,361,128,177—increase in 20 years, \$1,697,020,452. The valuation of taxable personal property in 1867 was \$436,404,633; the valuation in 1887 was \$335,898,389—decrease in 20 years, \$100,506,244. The valuation of taxable real property in 1867 was \$1,237,703,092; the valuation in 1887 was \$3,025,229,788—increase in 20 years, \$1,787,526,696. The State tax levied for all purposes in 1867 was \$12,647,218.71; in 1887 was \$9,075,046.08—decrease State tax in 20 years, \$3,572,172.63. The total amount of State taxes paid by the taxable property from 1867 to 1887, both inclusive, is about \$224,000,000; the total amount paid by personal property, \$37,000,000—taxes paid by real estate in 20 years, \$187,000,000. Average yearly State tax paid by the personal property in 20 years 16.52 per cent. Average yearly State tax paid by the real estate in 20 years 83.48 per cent.

Canals.—These important public works of the State during the year 1887 had accommodated a tonnage over 5,553,805. For 1884 the tonnage was 5,009,488; 1885, 4,731,784; for 1886 it was 5,293,982. These figures show that the canal system of the State still retains its usefulness. The tonnage for 1887 was composed as follows: Forest products, 1,529,809; agricultural products, 1,590,509; manufactures, 212,216; merchandise, 378,734; other articles, 1,842,537. Of this total,

3,968,767 tons went east; and 1,585,038 tons went west. The total tons carried by the several canals are as follows: Erie, 3,840,513; Champlain, 1,229,335; Black River, 111,847; Cayuga and Seneca, 195,933; Oswego, 176,177. The Legislature of 1887 appropriated \$550,000 to double the capacity of the locks by making each one as long again as it is at present. A similar appropriation was passed in 1888. Six locks on the Erie, near Syracuse, and two locks on the Oswego have been completed, and nearly all the rest are under contract. The original Erie Canal was completed in 1825, with a capacity for boats carrying 100 tons. Between 1836 and 1862 the prism was deepened so as to allow the passage of boats carrying 240 tons. The following canals, lateral to the Erie, were completed at the respective dates given: Cayuga and Seneca, 1828; Oswego, 1828; Chemung, 1831; Crooked Lake, 1833; Chenango, 1836; Black River, 1849; Oneida Lake, 1856; Genesee Valley, 1856. Some of the lateral canals are now abandoned.

Railroads.—The railroads of New York are under the supervision of a board of Railroad Commissioners, created by a law of 1882. The commissioners are appointed by the Governor and confirmed by the Senate. Much of the care and responsibility devolving upon this board has been removed by the appointment of U. S. Railroad Commissioners, under the Inter-State Commerce law. The State board of New York has paid particular attention to accidents. It finds that the principal cause of death and injury to passengers was getting on or off trains in motion, and was the result of their own want of caution. Employés most frequently met death by walking on the track. Experiments were made with patent couplers so as to ensure the safety of brakemen. The Legislature has not seen fit to pass the recommendations of the board in favor of crossings either above or below grade. Bridges have been closely inspected by the board; and attention has been called to the desirability of a uniform code of rules and signals. The elevated railroads of New York have voluntarily reduced their fares to 5 cents. On and after Nov. 1, 1888, it is required that all cars shall be heated with steam from the engine, and that stoves shall be no longer allowed.

The total number of miles of railroad track in New York is 12,035; locomotives, 3972; passenger cars, 4486; freight cars, 148,120; passengers carried, 81,463,709; passengers carried, reduced to a one-mile uniformity, 1,839,734,634. Total stock and debts, \$59,535,294; earnings, \$17,801,464; net earnings, \$4,242,279.

Banks.—The total amount on deposit Jan. 1, 1888, was reported as follows: Savings banks, \$590,458,751; banks of discount and deposit, \$193,324,267; trust companies, \$200,087,230.17; safe deposit companies, \$4,214,504.97. Total, \$988,084,753.14. One hundred and twenty-five savings banks were in existence Jan. 1, 1888, of which 7 were inactive. The total amount of resources of the saving banks of the State on the morning of Jan. 1, 1888, was \$590,458,751; Jan. 1, 1887, \$568,286,867; showing a net increase for the year of \$22,171,884. The increase during the year 1886 was \$33,750,234, and during the year 1885 it was \$28,609,137. On Jan. 1, 1878, the total amount of resources of the savings banks of the State was \$346,726,202, showing a net increase in ten years of \$243,732,549. The total estimated value of real estate held by savings banks of the State Jan. 1, 1888, was \$7,736,103. Of this amount \$6,730,439 represented the aggregate estimated value of bank buildings. The remaining amount, \$1,005,664, is the estimated value of real estate which had been acquired under foreclosure proceedings. On Jan. 1, 1888, the savings banks held \$5,776,048 in cash, and had \$33,630,607 deposited with State and national banks and trust companies incorporated under the laws of this State, making a total of \$39,406,650. On Jan. 1, 1887, it was \$36,632,120, indicating an increase of \$2,774,530. The deposits

held by the savings banks of the State on Jan. 1, 1888, amounted to \$505,078,751. On Jan. 1, 1887, they were \$482,486,730, showing an increase during the year of \$22,531,021, which sum includes \$16,731,002 of accumulated interest which was credited to depositors, leaving a net increase of deposits during the year of \$5,800,019. During the year 1887 the savings banks received \$179,021,049 from depositors, and paid to them \$173,070,683. A constant effort is making to enlarge the scope of investments for savings institutions. In 1887 a law was passed changing the legal status of building and loan associations and their mode of doing business. Among the amendments is one which allows such associations to do a savings bank business upon proper guarantees to the superintendent of the banking department. The number of banks of deposit and discount operated under the State laws is greater at the present time than it has been at any period subsequent to March 9, 1865, the date of the passage by the Legislature of the act enabling the conversion of State banks into national banks. Since Oct. 1, 1886, the unprecedented number of 16 new State banks has been organized and entered upon active business. On Oct. 1, 1887, the total of loans and discounts in State banks was \$115,042,599, out of the total resources, \$190,951,547. Among the liabilities were: aggregate capital, \$23,330,700; surplus, \$7,484,780; undivided profits, \$6,831,848; due to depositors, \$139,035,151. During 1887 the aggregate resources of the banks increased \$11,707,273; the increase in deposits was \$8,618,499; in loans and discounts, \$4,502,888, and in capital, \$1,235,000; the increase in surplus fund was \$839,188, and in undivided profits, \$788,173; the increase in cash items was \$6,332,801; the amount due from directors increased \$721,528; overdrafts, \$11,244; amount due from trust companies, State, national, and private banks and brokers, \$936,421, and U. S. legal-tender notes and circulating notes of national banks, \$188,876; the increase in bonds and mortgages was \$59,857, and in amount due to trust companies, State, national, and private banks and brokers, \$129,433; in miscellaneous liabilities, not classified, there was a net increase of \$232,994, and in loss and expense, \$13,368. During 1887 the net decrease in specie was \$869,968, and in stocks and bonds, \$408,898; the decrease in real estate was \$17,492. The amount due to the treasurer of the State of New York decreased \$21,671, and the amount due individuals and corporations other than banks and depositors, \$114,323. The net increase in the capital stock of banks, banking associations, and individual bankers was \$1,235,000. Of this amount \$870,000 was capital of new associations; \$400,000 resulted from the increase of the capital stock of the Bank of the State of New York from \$800,000 to \$1,200,000.

Insurance.—A law of 1887 reduced the number of poor co-operative and assessment life and casualty companies, and thus improved the quality of those that remained. It was also required that all fire policies written in the State shall hereafter be of a uniform style and printed in large type. For 1887 the net increase in life companies was 81,372 in policies, and \$252,081,384 in insurance. The number of such companies is 29, having assets, \$595,679,478; reserve, \$516,966,759; surplus, \$72,427,666. The number of fidelity and casualty companies is 10; assets, \$7,738,512; reserve, \$2,516,933; surplus, \$1,162,130. The number of co-operative companies is 171; assets, \$10,829,468, and total liabilities, \$1,654,823. There are 166 fire companies; assets, \$207,159,925; surplus, \$57,559,780. The number of marine companies is 16, with assets, \$22,286,141; surplus, \$11,250,457. A law of 1884 has now become operative requiring that the standard for the valuation of life policies and obligations shall be the actuary, or combined experience table of mortality, with interest at 4 per cent. per annum. Companies of other States are treated with the same measure that they render to New York companies in their respective

States. Assessment associations are now required to file their preliminary papers with the superintendent of the insurance department. A comparison of the business done in 1887 shows that the fire and marine companies fell away nearly \$1,400,000. The fire premiums received were \$18,425,955.69; fire losses paid, \$13,419,011.99; fire losses incurred, \$13,937,470.98. The estimated amount of expenses for the transaction of this business is \$5,527,786.72, which, if added to the incurred losses, makes a total of \$19,465,257.70, showing as compared with the premium receipts an apparent loss of \$1,039,302.01.

Prisons.—Three prisons are in operation: Sing Sing, having 1425 convicts in the year 1887; Auburn, 1111; and Dannemora, 760. Female convicts are sent to the several county penitentiaries. Under the contract system (by which the labor of every convict brought to the State an average of 40 cents per day) the prisons had more than sustained themselves in the years between 1881 and 1886. But since the passage of the law abolishing contract labor there has been a deficit—that for 1887 having been \$60,049, and that for 1888 being still greater. A commission appointed in 1886 to investigate and recommend a substitute for contract labor gave nothing practical in its report. In the meantime the labor agitators had demanded still further concessions, and the State account system (the successor of the contract system) was also abolished. Then it was enacted, at the extra session of the Legislature of 1888, that no machinery whatever should be used in the prisons, and that all the output should be of articles and materials for use in the several institutions of the State. This has resulted in the idleness of thousands of the convicts.

Labor Matters.—In 1883 a bureau of the statistics of labor was established under a commissioner who is charged with the duty of collecting and presenting to the Legislature statistical details as to strikes and all other phases of labor, together with the cause of the same. The later reports of the commissioner show that strikes have diminished in number. In 1886 there was created a board of three commissioners of mediation and arbitration to hear and consider appeals from local boards, and to investigate such cases. The board may subpoena witnesses, but it has no power to decide a dispute. Still it is claimed that the board has exercised a deterrent influence upon elements that otherwise would have made much more of a disturbance; and to its action is attributed the decreased number of strikes. In fact, many of the difficulties that arose were amicably settled between the employers and the employed after a brief hearing before the board.

The civil service is in charge of a board of three commissioners. Elaborate reports have been made, but it must be confessed that the reform cannot be carried on until the board is made absolutely independent of the Governor, at whose will each member retains his office.

Sanitary Affairs.—A State Board of Health has been in existence since 1880. Great progress has been made in examining the drainage and sewerage of unhealthy localities; and also in applying scientific principles to the choice of water supplies. The advances of cholera and yellow fever are closely watched by the board. Many specimens of beer and adulterated food and drugs have been analyzed and reported as evidences for prosecution before the law. The department relating to vital statistics has been greatly improved and every case of virulent or contagious disease has been examined with care. It is recommended that the Quarantine station, in New York harbor, be demolished, and that the cottage plan be substituted.

Charitable Institutions.—The institutions subject to the visitation of the State Board of Charities are as follows: 1. Those established and conducted by the State; 2. Those provided for and supported by counties and cities; and, 3. Those under the direction and management of incorporated benevolent organizations.

The first comprises hospitals and asylums for the insane, institutions for the blind, deaf and dumb, disabled soldiers and sailors, idiotic and feeble-minded, and houses of refuge and reformatories; the second, county and city poor-houses and alms-houses, with their infirmary and insane departments; and the third, orphan asylums and homes for the friendless, and special and general hospitals and dispensaries. The administration of out-door medical and other poor relief devolves upon the local officers of the poor of the various counties, cities, and towns, and the expense of this mode of relief is levied and raised by tax assessed upon these localities. The appraised value of the property held for charitable and correctional purposes, Oct. 1, 1887, was \$53,742,535.58 as against \$52,138,192.45, as appraised Oct. 1, 1886, viz.: By the State, \$11,187,649.80; by counties, \$2,751,894.86; by cities, \$4,348,500; by incorporated benevolent associations, \$35,454,490.92. Their reported indebtedness then was \$3,191,097.97 as against \$3,161,994.81, their indebtedness Oct. 1, 1886. The reported total receipts for charitable and correctional purposes in the State, for the fiscal year ending Sept. 30, 1887, were \$13,635,305.95, as against \$13,362,659.61, the receipts for the previous year being an increase of \$272,646.34, derived from the following sources: From the State, \$1,412,283.95; from counties, \$1,843,588.18; from cities, \$3,292,769.50; from individuals for the support and care of inmates, \$751,295.49; from contributions, donations, and legacies, \$1,558,934.72; from the income on investments, \$483,745.09; from all other sources, \$4,292,689.02. The reported total expenditures for charitable and correctional purposes in the State for the year ending Sept. 30, 1887, were \$12,574,074.67, as against \$12,027,990.01, the expenditures for 1886, or an increase of \$546,084.66. The number of beneficiaries in the care of the various charitable and reformatory institutions of the State, Oct. 1, 1887, was 63,816.

Education.—The educational interests of the State are in charge of the Board of Regents of the University, which has been in existence more than a century. The regents are authorized to incorporate colleges and academies, and have established uniform conditions on which such incorporation is granted. They inspect the academies of the State, prescribe rules for rendering their returns, apportion the moneys annually distributed among them, and report to the Legislature the statistical returns of colleges and academies, with such other information and recommendations as they may deem proper. Since 1844 they have been trustees, *ex-officio*, of the State Library, and since 1845 trustees of the State Museum of Natural History. They appoint the librarians and assistants of the State library, and the staff of the museum. They appoint the executive committee of the State Normal School at Albany, in concurrence with the superintendent of Public Instruction, who is chairman by virtue of his office. They are authorized to confer annually the degree of M. D. upon four persons nominated by each of the State Medical Societies, and may confer any degree above that of A. M. at their discretion. They are also authorized to appoint boards of medical examiners, and on their recommendation to confer the degree of M. D. Under the rules for admission to the bar they hold examinations and give certificates on subjects required, as preliminary to legal studies. The superintendent of Public Instruction has the oversight of the public schools. He also appoints State pupils to the institutions for the instruction of the deaf and dumb and the blind, and visits and inquires into the condition and management of these institutions. He apportioned among the counties the number of pupils in the State Normal School to which each is entitled. He has charge of all the Indian schools in the State; employs local agents to superintend them and visit them, and directs concerning the erection and repairs of their school-houses, and determines the branches of

instruction to be pursued in the schools. Normal schools are located in the following places: Albany, Brockport, Buffalo, Cortland, Fredonia, Genesee, New Paltz, Oswego, Potsdam, Oneonta. Laws have recently been passed enlarging the powers of the superintendent, and also requiring much more strict examinations before diplomas are issued. Graduates of colleges and kindred institutions are allowed diplomas without severe examination. The superintendent has completed an extensive work containing designs for cheap school-houses; and the book has been adopted by the commissioners of the National Bureau of Education. The income for public schools in 1887 was \$16,433,128. Of this amount there was expended: For teachers' wages, \$9,306,425; school-houses and sites, \$2,394,004; libraries and apparatus, \$400,000. The number of school districts is 12,072; teachers, 22,708; children between 5 and 21 years of age, 1,763,115; children attending school, 1,037,812; log school-houses, 55; frame school-houses, 10,128; brick school-houses, 1420; stone school-houses, 363. Total number of school-houses, 11,966.

Militia.—The military code provides that the "aggregate force" of the National Guards "in times of peace, fully armed, uniformed and equipped, shall not be less than 10,000 and not over 15,000 enlisted men." In 1887 the force consisted of 726 officers and 11,909 enlisted men, aggregating 12,635. The aggregate now approximates 13,000 officers and enlisted men. The inspector-general reported that there were present at the annual inspection and muster 10,444 officers and enlisted men. There are 15 regiments, 1 battalion and 44 separate companies of infantry, and 5 batteries of artillery, organized as 4 brigades. Armories and arsenals have been erected in the following places: Buffalo, Rochester, New York, Utica, Syracuse, Auburn, Oswego, Watertown, Brooklyn, Newburgh, Kingston, Binghamton, Troy, Flushing, Oneonta, Elmira, Walton. The following armories are now to be erected, under recent acts of the Legislature: Saratoga Springs, Mount Vernon, Hoosick Falls, Albany. The Remington rifle is still in use; but it is likely to be superseded with rifles of a smaller calibre, such as are used by the U. S. army. A State camp of instruction has been established at Peekskill, in which nearly half of the militia are instructed every year. Recent reports show that, in the civil war, the State of New York furnished one-sixth of all the troops comprising the Union army. During that war the State furnished 20 major-generals and 97 brigadier-generals, and 65 New Yorkers were brevetted major-generals, and 220 brigadier-generals of volunteers, and 115 received the U. S. medal of honor for bravery and distinguished services in the field. In the numbers brevetted only those who did not obtain the full rank are included.

Judiciary.—In 1846 the present Supreme Court was constituted to exercise the powers of the Supreme Court, the Court of Chancery, and the Circuit Court, as exercised at that time. This court has general jurisdiction in law and equity. There are 8 judicial districts, each one of which has 5 justices, who are elective. The district comprising New York city is entitled to 2 additional justices. The salary is from \$6000 to \$8500, with an allowance of \$1200 for expenses. General and special terms of this court are held. The court of last resort is known as the Court of Appeals. This consists of 7 judges, elected by the whole people of the State, one of whom shall be chief-justice. The salary is \$10,000, with \$500 additional for the chief-judge. The term of office in this court and the Supreme Court is 14 years, with disqualification at the age of 70. The Court of Appeals has full power over all decisions of the Supreme Court. A quorum is 5 judges, and 4 must concur in order to pronounce a judgment. The Legislature may advance any case from the Supreme Court directly to the Court of Appeals.

Indians.—There are 9 reservations controlled by the State and occupied by Indians, of whom there are

4707. Efforts have been made periodically by interested parties outside to have the State divide the lands in severalty among the Indians, the outsiders lying in wait to secure the property. This has not been done, but a commission has been appointed to examine into the best method of disposing of the reservations and of caring for the Indians generally.

Census.—The Constitution of the State requires a census every ten years, which shall be taken midway between the decennial censuses of the United States. The last State census was taken in 1875—population, 4,698,958. The U. S. census of 1880 gave 5,082,871. No census was taken in 1885, because the governor refused to sign a bill relating to the census presented to him by the Legislature of that year. The governor called the Legislature together in extraordinary session to pass another bill. The Legislature gave him the same bill, which he once more refused to sign, and no bill has been presented to him since that date. The probability is that there will be no State census till 1895. A new census would give the cities of New York, Brooklyn, and Buffalo a much larger representation in the Legislature, and the opposition to any census is led by the rural districts, which fear a reduced representation. The Senatorial districts still number 32, and the Assembly (or popular branch) districts number 120. If the Senatorial and Assembly districts were as small as they are in the States of New England, the Legislature would have about 1200 or 1500 members, instead of the 160 established by the constitution.

Boundaries.—Slight controversies relative to the outlines of the State led the Legislature of 1867 to direct the regents of the university to examine and ascertain the true location of its boundaries. A law of 1875 empowered the regents to act in accordance with the resolution, and also (in connection with the authorities of Pennsylvania and New Jersey) to replace any monuments that had been removed. In 1880 the regents were authorized to select three of their number to confer with commissioners empowered to act for the States named. Under the provisions of this law the boundary line with New Jersey was completed in 1882, and that with Pennsylvania in 1885.

Cities and Counties.—There are 30 cities in the State, as follows: Albany, Amsterdam, Auburn, Binghamton, Brooklyn, Buffalo, Cohoes, Dunkirk, Elmira, Hornellsville, Hudson, Ithaca, Jamestown, Kingston, Lockport, Long Island City, Middletown, Newburgh, New York, Ogdensburg, Oswego, Poughkeepsie, Rochester, Rome, Schenectady, Syracuse, Troy, Utica, Watertown, Yonkers. The city of Amsterdam was incorporated by the Legislature in 1887, and the cities of Hornellsville, Ithaca, and Middletown in 1888. All of the cities, with the exception of Hornellsville and Middletown, have a population of over 10,000. The counties still number 60; but there is a movement to create Lincoln county out of portions of several counties to the south and west of Rochester, and Susquehanna county near the headwaters of the river of that name to the west of Cooperstown. The county of the largest area is St. Lawrence, 2880 square miles; and the county of the smallest area is Richmond (Staten Island, in New York harbor), 59 square miles.

Centennial Celebrations.—Appropriate notice was taken of the several battles and the leading civic events of the war of the American Revolution that took place within the boundaries of the State. The centenary of the adoption of the Constitution of the State was celebrated at Kingston, where the first State government was formed, on July 30, 1877. The original Senate house is still in existence. A celebration of the battle of Oriskany (wherein the American general, Nicholas Herkimer, stopped the British advance of St. Leger and the Six Nation Indians to meet Burgoyne near Albany) took place upon the battle ground near Utica, Aug. 6, 1877, and a monument was un-

veiled. On Oct. 17 of the same year the centennial of the battle of Saratoga (*q. v.*) took place on the battle-ground, and a monument has been erected upon the spot. The one-hundredth anniversary of the battle of Bemus Heights was celebrated Sept. 19th. A monument to mark the massacre was unveiled at Cherry Valley, Aug. 15, 1877. During the year 1879 the centennials of the advances and victories of Sullivan's expedition against the Seneca Indians were celebrated at Elmira, Waterloo, Geneseo, and Aurora. At the centennial of the promulgation of the Federal Constitution in Philadelphia, Sept. 17, 1887, New York was represented officially, and it will give especial attention to the centennial, in 1889, of the inauguration of George Washington as the first President of the United States. The 30th of April in that year has already been made a legal holiday. The centennial of the adoption of the Constitution of the United States by the State of New York was celebrated, at Poughkeepsie, July 26, 1888.

After the completion of the Senate chamber of the new capitol at Albany in 1881 (see ALBANY) the Senate staircase was completed and progress made upon the tower, but for several years no appropriations were made owing to a political quarrel between the governor and the Legislature. In 1888 \$275,000 were appropriated to take down the stone ceiling of the Assembly chamber (which had become unsafe owing to faulty construction) and to replace it with a ceiling of iron and wood; \$140,000 were also appropriated to finish the rooms set apart for the State library. The cost of the building to 1888 is \$18,000,000. The old capitol and State library were removed in 1883-4, and the Capitol Park has been laid out in harmony with the Academy Park adjoining.

Recently strict laws forbidding the manufacture or sale of oleomargarine have been enacted. Safeguards have been thrown about deer, fish, and other game in the Adirondacks and Catskills. Concessions have been made to the laboring men in various ways, including shorter hours on State work and the requirement that (for such work) stone must be cut where it is placed in position. A new law forbids the sale of liquors at or near county-fairs. Hanging is superseded by death from electricity, in capital cases, after Jan. 1, 1889.

(F. G. M.)

NEW YORK CITY. The province of New York

See Vol. XVII. was divided into 12 counties immediately upon its final conquest by the p. 457 (p. 469 English in 1683. One of the 12 was Am. Rep.) New York. The original area of this county was much larger than the 39 square miles credited to it by the State census of 1875. A recent law has made the boundaries of the city of New York co-extensive with those of the county, and still more recent additions north of the Harlem River (known as "the annexed district") make the present area 41½ square miles. The State census of 1875 made the population 1,041,886; that of the United States in 1880, 1,206,299. No State census was taken in 1885; but a fair estimate gives the population in 1888 about 1,500,000. According to the census of 1880, 727,629 of the inhabitants were American born, and 478,670 of foreign birth. Of these, 198,595 were from Ireland, 29,767 from England, 8683 from Scotland, and 929 from Wales. Germany contributed 153,482; Italy, 12,233; France, 9910; Russia, 4551; Spain, 669. There were 17,937 New-Jersey-born New Yorkers; 11,055 from Pennsylvania; 10,589 from Massachusetts. Voters registered Oct., 1888, 286,547.

Government.—The present charter is a law of 1882, known as the "Consolidation Act." For a long time the mayor had almost absolute power of appointment, but later his power was very much restricted. A committee of the Legislature, in 1884, made a thorough examination of the government of the city, and recommended that the power and responsibility of the mayor should be increased; but the recommendation was

headed only so far as to give him power to appoint independently of the board of aldermen. As an outcome of the investigation of the Broadway street railroad franchise a law was enacted, in 1886, that the president of the board of aldermen (made elective in 1884) should be elected for two years, instead of for one year; and in 1887 it was enacted that the aldermen should number 25, exclusive of the president, and that they should hold office for one year. The board of police commissioners consists of 4 members, 2 of whom belong to each of the great political parties. It was organized as a non-partisan board, but as a matter of fact, from its very constitution, it is partisan. The patronage of the department is divided between the commissioners, and a large part of their business has been in the past to satisfy the claims of the two political parties whom they represent. The comptroller, the chief financial officer, was made elective in 1884; and the sheriff is likewise elective. The department of public works is administered by a single head appointed by the mayor, and removable for cause; and the department of charities and correction, under 3 commissioners, is constituted in the same way. The board of education consists of 21 commissioners, one-third of whom go out of office every year. The elections are held in November along with the general elections for State officers. For election expenses over \$200,000 are appropriated annually by the city.

Courts.—The amended judiciary article of the State constitution provides: "The Superior Court of the City of New York, the Court of Common Pleas for the City and County of New York are continued, with the powers and jurisdiction they now severally have, and such further civil and criminal jurisdiction as may be conferred by law." These courts were reorganized in pursuance of this article, under various legislative enactments, and by the laws of 1873 were termed "Superior City Courts," and were vested with original jurisdiction, at law and in equity, concurrent and co-extensive with the Supreme Court, of all civil actions, and of all special proceedings of a civil nature. Appeals are taken directly from these courts to the Court of Appeals of the State. The Court of Common Pleas of the City and County of New York is the oldest judicial tribunal in the State. It was continued under the constitution of 1846. The three judges in office when the amended judiciary article was adopted were continued, and the election of three additional judges was directed. The Superior Court of the City of New York was established by an act passed in 1828. It was the principal commercial court. Equity jurisdiction was conferred upon it by the judiciary act of 1847. Three justices were added in 1849, law and equity jurisdiction given, and cases were transferred to it from the Supreme Court.

The fire department consists of 84 steam fire-engines, 2 water-towers, 32 hook-and-ladder trucks, a life-saving corps, 1080 miles of fire-alarm telegraph, 980 alarm-boxes, 260 horses, and 1000 men. It costs \$1,700,000 a year. There are 73 companies, making 12 battalions, each under a chief of battalion (see FIRE). The police department has 35 precincts and station-houses, 75 patrol-wagons, 6 courts, and 3200 men (each getting \$800 to \$1200 a year). The head-quarters is at 300 Mulberry street, where is kept the "Rogues' Gallery" or photographs and records of notorious criminals.

Distances.—Battery to City-hall, $\frac{3}{4}$ mile; to Canal street, $1\frac{1}{4}$ mile; to Fourth street, 2 miles. Above Third street the blocks between the streets bearing numbers are 20 to a mile, and the blocks between the avenues are 6 to a mile.

Municipal Buildings.—Although having a spacious City-hall and court-house, in the City-hall park, New York pays over \$100,000 annually as rental for other offices. A new municipal building is projected, which will also be the terminus of the Brooklyn Bridge and the several railroads converging toward that point.

Finances.—The municipal debt in 1888 is

\$144,995,641. The assessed value of real estate in 1887 was \$1,254,491,849, a gain of \$50,550,784 in one year. Nearly half of this gain was above Eighty-sixth street. The total increase for six years, including 1887, was \$277,756,650. The assessed value of personal property in 1887 was \$246,508,151, an increase of about \$36,000,000. The total valuation in 1887 was \$1,500,000,000, an increase of \$400,000,000 in ten years. The city budget of 1888 was \$33,800,000, or \$2,000,000 greater than in 1887; and the rate of taxation was \$2.20 per \$100, as against \$2.16 in 1887. The following table shows the total amounts allowed for 1887 and 1888, and the appropriations, respectively exceeding \$1,000,000:

Objects and Purposes.	1887.	1888.
State taxes.....	\$4,258,527.93	\$4,064,179.24
Interest on city debt.....	7,391,814.39	7,116,171.54
Redemption of city debt.....	975,779.25	1,773,884.01
Public works.....	2,759,720.00	3,180,309.00
Park department.....	840,750.00	1,014,650.00
Charities and correction.....	1,498,300.00	2,343,372.00
Police department.....	4,235,867.06	4,415,255.66
Street-cleaning department.....	1,050,000.00	1,259,459.00
Fire department.....	1,804,765.00	1,976,492.00
Board of education.....	3,994,088.00	4,303,167.00
Salaries, judiciary.....	1,014,160.00	1,055,540.00
Asylums, etc.....	1,426,076.80	1,142,952.44
Totals.....	\$34,343,022.55	\$37,051,053.93
Less general fund.....	2,500,000.00	3,251,053.93
Total.....	\$31,843,022.55	\$33,800,000.00

Port-Officers.—The governor and the Legislature appoint certain officers to care for the port of New York. They consist of the health-officer, a captain, the commissioners of quarantine, the port-warden, and the harbor-masters. A law of 1883 abolished the fees of the captain and the harbor-masters; and a law of 1888 abolished the fees of the health-officer, which had occasionally reached \$100,000 in a single year. In place of the fees salaries were substituted. The State Board of Health has some control over this department, more especially in regard to the prevention of the importing and the spread of contagious diseases.

Steamships and Railroads.—The Cunard line has recently added to its fleet the Etruria, which has made the fastest time between Queenstown and New York—6 days, 1 hour, and 55 minutes. The Anchor line has added the City of Rome, the largest passenger steamer afloat. Her length is 560 feet and her breadth 52 feet. Her engines are of 8000 indicated horse-power, and are capable of being worked up to 15,000 horse-power. She has accommodations for 480 first-class passengers. To the Inman line has been added the City of New York, with longitudinal compartments and twin engines which are expected to secure great speed.

In 1883 what is known as the West Shore Railroad was constructed along the western bank of the Hudson River from Weehawken to Albany, and thence westward to Buffalo. The road is now under a long lease to the N. Y. Central Railroad. This road gives direct access from Washington and Philadelphia to Saratoga and the Adirondacks. The Baltimore and Ohio Railroad will have a terminus at Staten Island; and it promises quicker time to Philadelphia and Washington.

Street and Elevated Railroads.—There are over 40 lines of horse-cars in the city, with the uniform fare of 5 cents. The omnibuses which formerly crowded the streets have been removed, and there is but one line of stages, which runs up Fifth avenue to Seventy-second street. There are four elevated roads, viz., the Second, Third, Sixth, and Ninth avenue. All of them extend the length of the city, starting from South Ferry, which is at the extreme lower end. There are also branch roads to Brooklyn Bridge, the Grand Central depot, and other points. The speed of the trains is about 15 miles an hour. The fare on all the elevated

roads is 5 cents, with no extra charges for transfers to the branch lines. The reduction from 10 cents was made voluntarily.

Rapid Transit.—The resources of the elevated railroads are being taxed to their utmost, and relief is sought through another elevated railroad in Fifth avenue, the cable railroads already partially in operation in the northern districts, and more particularly by new roads under the surface. Of the latter there are three distinct plans. The first is the Arcade charter to construct an underground road through Broadway. The second is to build a road under Elm street, to the eastward of Broadway; and the third, that of the City Railway Company through the blocks to the westward of Broadway.

Bridges and Tunnels.—The Brooklyn Bridge (see BRIDGES, Fig. 90) has been completed at a cost of \$15,500,000; but the methods of its administration are not satisfactory. The length is 5989 feet, and it is 89 feet wide. It is suspended from 4 steel-wire cables, each 16 inches in diameter. In the centre is an elevated promenade, on each side of which is a railroad track for passenger-cars propelled by a stationary engine. Outside of the railroad track, on each side, are the roadways for vehicles. From the under side of the bridge, in the centre, to the water, is 135 feet. Ordinary vessels can easily pass beneath. Very large sailing-vessels have to lower their topmasts to go under. The fare for foot passengers is one cent, or if tickets are bought, one fifth of a cent. The single fare on the cars is 3 cents, or 10 tickets for 25 cents. A new bridge has been constructed across the Harlem River also (just above the High Bridge), near Two Hundredth street, to connect the upper districts. The tunnel under the North River has not yet been completed.

Parks and Streets.—The Central Park now covers 362 acres. Riverside Park, handsomely laid out, occupies the high bank of the Hudson, from Seventy-second to One Hundred and Thirtieth street, 3 miles long, and averaging 500 feet wide, with 178 acres of land, much of which has been improved. A driveway, cut into 4 broad sections by curbing ribbons of lawns and trees, sweeps over the hills and along the edge of the bluff, affording views of the Hudson River, Weehawken, Guttenberg, Edgewater, the Palisades, and upper Manhattan. On an elevation near the north end of the park is the brick tomb in which Gen. Grant's body was temporarily laid, Aug. 8, 1885. Morningside Park, a long drawn and nearly unimproved public ground of 47 acres, extends from One Hundred and Tenth street to One Hundred and Twenty-third street, near Tenth avenue, and has a costly and far-viewing driveway. It lies on the east side of the ridge which separates Harlem plains from the Riverside Park and Hudson River. In the "annexed district" parks known as "Pelham" and "Bronx River" have been laid out but not yet improved. The new streets and avenues of the city are laid out with the greatest regularity, and they are spaced according to the distances already noted.

Statues and Monuments.—The latest additions may be noted briefly. The obelisk which stood originally before the Temple of the Sun at Heliopolis, and was removed by Tiberius to Alexandria, was presented in 1877 by the Khedive of Egypt to the city of New York. It was successfully transported by Lieut.-Com. Henry H. Gorringer, U. S. N., the entire cost of the removal and erection being borne by the late William H. Vanderbilt. The bronze statue of the Indian Hunter and The Pilgrim, a picturesquely posed and attired heroic bronze statue, both by J. Q. A. Ward, stand in Central Park. Bartholdi's statue of Liberty Enlightening the World stands on Bedloe's Island, in the harbor. It is a female figure made of copper, 151 feet 1 inch high, standing on a pedestal 151 feet 10 inches high, and was presented by the French people to the people of the United States. In the apraised right hand is a torch, lighted by electricity, and in the

left hand is the Constitution. The copper is about one-fifth of an inch thick. The pedestal was built by popular subscriptions, and, with the statue, cost \$1,000,000.

Fine Arts.—The Metropolitan Museum of Art stands in Central Park, near Fifth avenue and Eighty-third street. The first movement towards founding the museum was made in 1869, and for some years its collections were kept in rented buildings. The present fire-proof brick and granite modern Gothic building, 218 feet by 95, was dedicated in 1880. New structures are building in connection. In the west-entrance hall are many fine pieces of statuary—Beer's medallion of Michael Angelo, the Apollo Belvedere, Hiram Powers's California, George Washington, Alexander I. of Russia, Roncanelli's Rose of Sharon, Albano's Thief from Dante's Inferno, Mozeir's Rispah, Fischer's Goethe, McDonald's Gen. Hancock, Schwanthaler's Dancing Girl, Marochetti's Washington, Houdon's Franklin, Connelly's Thetis, and many fine works by Barye, Barbedienne, Thorwaldsen, Reinhart, Canova, Launt Thompson, and others. On the southwest stairway is a collection of 43 water colors by William T. Richards, of New England coast and White Mountain scenes. The great hall contains many pieces of the famous Cesnola collection, from Cyprus, and various other interesting collections of rare objects of art. In the galleries are the collections of gold jewelry and Greek and Phœnician glass from the Cesnola treasure-trove; and also the Japanese, Egyptian, and Oriental porcelain and antiquities. In the western galleries are many of Kensett's exquisite landscapes, Gifford's and Durand's master-pieces, Frère's Oriental scenes, Couture's Decadence of Rome, Moignan's Outrage at Anagni, Madrazo's portrait of Robert L. Stuart, Bonnat's portrait of John Taylor Johnston, Meyer Von Bremen's genre pictures, Granet's Benedictines, Hellquist's great Swedish historical scene, Wylie's Death of a Vendean chief, William M. Hunt's Boy and Butterfly, Marr's Mystery of Life; landscapes by Cropsey, Inness, and Breton; Boughton's famous Judgment of Wouter Van Twiller, Schreyer's Arab scenes. The east gallery is devoted to pictures by the old masters—Baroccio, Albani, Titian, Correggio, Caravaggio, Tintoretto, Tiepolo, Sassoferrato, Bordone, Andrea del Sarto, Ghirlandajo, Rembrandt, Rubens, Jordaens, Hals, Van Dyck, Cuyp, Wouverman, Ostade, Teniers, Terburg, Breughel, Ruysdael, Steen, Velazquez, Murillo, Copley, Stuart, Trumbull, Jarvis, Etty, Lely, Poussin. Many pictures in this remarkable collection have romantic histories, extending over centuries. Rosa Bonheur's Horse Fair, purchased at the Stewart sale for \$59,000, was presented by Cornelius Vanderbilt. The magnificent collection of paintings bequeathed to the museum by the late Catherine L. Wolf is in an annex building erected for its reception. The Lenox Library's Picture-Gallery, at Fifth avenue and Seventy-first street, has about 150 fine paintings, including Munkacsy's Blind Milton dictating Paradise Lost to his Daughters, Turner's A Scene on the French Coast and Fingal's Cave, Horace Vernet's Siege of Saragossa, Gainsborough's A Romantic Woody Landscape, Andrea del Sarto's Tobit and the Angel, Delaroche's The Field of Battle, Church's Cotopaxi, Thomas Cole's Expulsion from Paradise, Bierstadt's Yosemite. There are portraits by Leslie, Stuart, Trumbull, Inman, Peale, Copley, Daniel Huntington, S. F. B. Morse, Healy, Pine, and others. The statuary includes Crawford's Sleeping Shepherd Boy and Children in the Wood, Rauch's Victory, Powers's La Penserosa, Ball's Abraham Lincoln, Sir John Steele's Sir Walter Scott, Trentanore's Napoleon.

Underground Wires.—A law of the State created a board of subway commissioners to take charge of placing underground the telegraph, telephone, and electric-lighting wires which had been heretofore strung overhead. The first commission having failed

to carry out its purpose, a law of 1887 reconstructed the commission with larger powers. The new board perfected plans which were designed to supply accommodations on fair and impartial terms, to all companies and others duly authorized to make use of the same, affording the greatest possible convenience for placing, removing, repairing, altering, and connecting said conductors, combined with the least possible interference with the other uses to which the public streets are subject. Up to Jan. 1, 1888, 20,000 feet of trench had been excavated for telegraph and telephone service, and 900,000 feet of single ducts had been constructed, each duct averaging 80 wires. This represented about 14,000 miles of wire. Additional wires have been laid for electric light and power service. More than 1000 unsightly poles have been removed from the streets.

Aqueduct.—The inadequacy of the water supply of New York brought from Croton River over the High Bridge led to a law of 1883 creating an aqueduct commission to be appointed by the mayor. The commission was enlarged by a law of 1886. In 1887 a committee of the Senate examined into certain allegations of fraud and defective construction, and a third law was passed making the commission consist of the mayor, the comptroller, and the superintendent of public works, together with 4 citizens of the city to be appointed by the mayor. In 1884 it was decided that the aqueduct should have a conduit 14 feet in diameter. The work was begun in 1884, and it has since been decided to extend the terminus to Quaker Dam. The aqueduct runs under the Harlem River for safety in case of war or social disturbance. The length of the aqueduct will be 33½ miles, nearly all of which is completed. The cost thus far is \$10,000,000, and the total cost will approach \$20,000,000.

New Buildings.—The Produce Exchange, at the foot of Broadway, is built upon 15,000 piles and cost over \$3,000,000. The building is 307 by 150 feet in area and 116 feet high. The main hall is 220 feet by 144 feet and 60 feet high. The Mercantile Exchange has a new brick and granite building at Hudson and Harrison streets. The Cotton Exchange has a building of yellow brick at Hanover Square, south of Wall street. The College of Physicians and Surgeons has new and extensive buildings at Tenth avenue and Sixtieth streets, the gift of William H. Vanderbilt and his family. The reconstructed building of the Equitable Life Insurance Company in Broadway is considered the finest structure in the world for business purposes. Other buildings recently constructed are the Potter, the Mills, the Drexel, the Morse, the Stewart, and Temple Court.

Churches.—The Episcopalians now have 76 churches in the city; the Catholics about 60; the Methodists, 76; the Presbyterians, 55; the Baptists, 43; the Reformed (Dutch), 24; the Congregationalists, 8; the Universalists, 4; the Unitarians, 2. St. Patrick's cathedral, probably the most magnificent church in the United States, was projected in 1850 by Archbishop Hughes and the plans drawn by James Renwick. The corner-stone was laid in 1858; and on May 25, 1879, the cathedral was dedicated by Cardinal McCloskey. It has cost over \$2,000,000. It is in thirteenth-century decorated Gothic, the material being fine white marble. It is a Latin cross 306 feet long and 120 feet wide (140 at transepts) and 108 feet high, with a noble clerestory upheld on long lines of clustered marble columns and carrying a lofty and richly ornamented ceiling. On each side of the front gable, which is 156 feet high, the carved and pinnacled spires are to be carried to a height of 328 feet.

Theatres.—Among the places of amusement lately built is the Metropolitan Opera House at Broadway and Thirty-eighth street. It is capable of seating 6000 persons, the dimensions being 200 by 260 feet. The Casino, at Broadway and Thirty-ninth street, is a Moorish structure set apart for comic operas. The

new Broadway Theatre is also among the most attractive buildings of the city.

Club Houses.—The new Union League Club House, at Fifth avenue and Thirty-ninth street, cost \$400,000. The Athletic Club building, at Sixth avenue and Fifty-fifth street, is the most splendidly appointed building of its kind. (E. G. M.)

NEW YORK CITY, UNIVERSITY OF. This institution of learning owes its origin to a desire that arose in the beginning of the second quarter of this



century in certain merchants, bankers, and professional men of New York to secure—the language of a conference of nine gentlemen held December 16, 1829, is here quoted—"the establishment of a university in the city of New York on a liberal and extensive scale." In answer to the call of this conference a public meeting was held Jan. 6, 1830, in the rooms of the Historical Society, by which a standing committee on subscriptions was organized. On the following Oct. 15th the subscribers of money for the new foundation sought incorporation and chose a council to represent them. The incorporation of "the subscribers and shareholders" was granted by the Legislature April 18, 1831, under the title of "The University of the City of New York." The charter then granted provided that, besides thirty-two shareholders, the council should include the mayor and four members of the common council of the city of New York; that every year one-fourth of the council should go out of office, their successors to be elected by the whole body of shareholders, and that no one religious sect should ever have a majority of the board or council. The history of this country was then not far enough written to show these three things: 1. That to expect any care of higher education by public officials is to be deluded, unless the foundation is to be wholly controlled by the State, a control undesirable in the American republic; 2. That to plan a university as a joint-stock company to yield material dividends is to disfigure charity; 3. That to ask citizens in general to endow a foundation and yet to forbid to those citizens who open their purses the controlling voice is to dam up benefactions.

These three truths became manifest to all the friends of the university, and in 1883 three amendments to the charter were secured: (1) Abolishing the connection of the city government with the council; (2) Constituting the council the sole shareholders and corporation, giving to this body the election of a new class of eight members every year to succeed the class whose terms expire; and (3) expunging the denominational test by allowing members of council to be chosen without regard to their church affiliations.

The university thus assumes a position in harmony with the American idea, that higher education is to be offered by voluntary corporations as a loan to the youth of the country, to be repaid by them as educated citi-

zens and members of the liberal professions. The council of the university, as now constituted, is about equally divided between members selected from the alumni and from the whole body of citizens.

The plan of the university in the minds of its founders was broad and far-seeing. Hon. Albert Gallatin, president of the council in 1831, said in a public meeting, Oct. 20, 1830, as to the chief objects of the university: "One is to complete the studies commenced in the colleges, . . . another is to diffuse knowledge." The early statutes contemplated a department of arts and science, corresponding to the faculty of philosophy in a German university, a department of medicine and a department of law. The first department it was intended should exist in two divisions, the first to accomplish such objects as were named by Mr. Gallatin, the second to correspond to the well-known American "college."

The following is the statute as to the two divisions of the department of arts and science. The first "shall comprise professorships for instruction in the higher branches of literature and science, which shall be increased according to the progress of discovery, the wants of the community, and the financial means of the university. The second shall embrace what is usually deemed a full course of classical, philosophical, and mathematical instruction, and also a complete course of English literature." This statute, which contemplated what is now known as the work of "the graduate division," or "university work proper" in arts and science, was a half century ahead of the demand for such work in America, which is only now beginning to be made and to be responded to.

Nevertheless, university work proper, so far as it aims "to diffuse knowledge," has been achieved by professors of the university from the first. Samuel F. B. Morse, while a professor, conceived the recording telegraph, and in an address in 1853 named as its birth-place the present Philomathean Hall.

Prof. John W. Draper here first applied photography to the representation of the human countenance. Among other deceased professors eminent for their labors for the public were Henry P. Tappan, Tayler Lewis, George Bush, John C. Draper, and Henry Draper.

It is probable that the chief work of the faculty of arts and science in time to come will be in accomplishing the two objects pointed out by Albert Gallatin, namely: the instruction of graduate students, and the diffusion of knowledge.

In 1886 a graduate division was formally opened, which enrolled the first year twelve resident students and the second year thirty-one, besides several non-resident students. In answer to demands upon this division instruction in new fields has been begun, as, for example, comparative religion and pedagogics.

But the main effort of the faculty of arts and science has been expended from the beginning in carrying on undergraduate instruction, such as ordinarily leads to the bachelor's degree. A college has flourished which has graduated a class each year, beginning with 1832. Its standard of admission meets fully the recommendations of the State regents. Election is offered between the "scientific" course leading to the degree of bachelor of science, and the "classical," leading to bachelor of arts, and also between alternative studies in limited measure.

But every student, in order to take the bachelor's degree, must have pursued extended study in each of the three fields into which learning is divided, viz.: (1) language and literature; (2) mathematics and natural science; (3) philosophy and history. The least amount of class work assigned any of the three fields is four hundred hours in the four years' course. Fourteen professors and instructors take part in the work for undergraduates. The number of undergraduate students is at the present time 130.

The year is divided into three terms of thirteen weeks

each, including certain recesses. But in certain years the third term is shortened to twelve weeks. The tuition is free in the ordinary undergraduate course, and there are certain prizes and fellowships. There are no halls, students being expected to reside at their own homes or in approved families. Besides the graduate division, and the college proper, the department of arts and science includes in its plan whatever technical or professional schools, outside of law, medicine, or theology, the university may establish. At present there exist a school of civil engineering, a school of chemistry and assaying, and a school of pedagogy. The degree of civil engineer is given to such students as have taken the degree of bachelor of science, and have pursued the special engineering course for four years, the last year to follow the attainment of the bachelor degree. No degree is given for special work in chemistry. The school of pedagogy offers instruction in the philosophy of education to teachers of higher attainments and experience. This school has been recently founded. Other professional or technical schools are in contemplation.

The work of the faculty of arts and science is carried on in the building on Washington Square, East, extending from Washington Place to Waverley Place. This building, erected between 1832 and 1835, is conspicuous even among the many later edifices of New York city. It contains well-furnished, though not large, laboratories of physics and of chemistry, a geological cabinet, and a library. Great advantage is derived from the nearness of the Astor Library.

The department of medicine, commonly known as the University Medical College, is the second department of the university in age, but the first in the number of its professors and students. It was organized in 1841, under a faculty of six professors, of whom the best known are Dr. Valentine Mott and Dr. John W. Draper. The building was on Broadway, near Bond, and not far from the main university edifice. In 1851 a larger edifice was erected on Fourteenth street, adjacent to the Academy of Music. Upon the burning of this, in 1876, the faculty removed, after a temporary stay in the New York Hospital, to East Twenty-sixth street, fronting the Bellevue Hospital Square. A temporary building was used until 1879, when the present main edifice was erected. To this the west wing was soon added, and in 1887 the east wing, which is "The Loomis Laboratory." The main building contains the lecture-room and the amphitheatre, each seating 500 students, together with the professors' private rooms and the dissecting-room. The west wing contains eight section-rooms, or small lecture-rooms. In these the material available to the university, through its dispensary and through the department of the commissioners of charities and corrections, is brought under the observation of each student, and thoroughly utilized in the system of "section-teaching" devised by this faculty and peculiar to this school. The college dispensary treats over 9000 patients annually. The material for clinical lectures from Bellevue Hospital, and other hospitals and dispensaries, with which the lecturers are connected, is so great that the faculty in 1885 resolved to provide special facilities for advanced students in the way of instruction in diagnosis and treatment. The graduating class is divided into sections of twenty-five each, which receive separate instruction for one or two hours daily throughout the term, under the ten principal professors. In 1886 an unknown friend of the university, by the gift of \$100,000, secured to the department of medicine a laboratory-building, attaching to his gift two conditions: first, that the name of the donor should not be made public; and second, that the building should be known as "The Loomis Laboratory of the Medical Department of the University of the City of New York." The building, five stories fire-proof, is furnished with every valuable accessory for its purposes. Laboratories of materia medica, physics, chemistry, physi-

ology, biology, and pathology are found in succession by one ascending from the first to the fifth floors.

For the degree of doctor of medicine three years of study are required, including two full winter sessions of lectures, the second in this college, with the passing of written examinations under seven professors. There are three sessions of study: The preliminary, in September; the winter session, October to March; the spring session, March to May. The attendance of students has reached 649 in 1888. The total number of graduates exceeds 5000. The professors and lecturers number 60. Nearly 100 students are enrolled from countries other than the United States. Liberal provision is made for the aid of meritorious students.

The department of law in the university, commonly entitled "The University Law School," was fully planned in 1835 by the Hon. Benjamin F. Butler, Attorney-General of the United States, and his plan was adopted by the council. The position of senior law professor was offered to Mr. Butler and accepted, to take effect in 1837. This plan and the correspondence relating thereto were published in 1835. But the execution of the plan was arrested, and it was not till 1858 that the faculty of law was organized. Since that date instruction has been carried on without intermission. The annual average enrolment of students has been about fifty. The number in 1888 is one hundred. The course for the degree of bachelor of laws is completed in two years, terminated by examinations both oral and written.

In addition to the three professors there are seven lecturers chosen from among the eminent members of the New York bar, who deliver each a course upon a special field of legal learning. There is a special prize given to the junior passing the best examination, and prizes to seniors for pre-eminence in the oral examination and in the written.

The law library was founded in 1863, by John Taylor Johnston, and has received some large additions. Its collections are supplemented by those of the neighboring Astor Library. The lecture- and library-rooms of the law school are in the main university building.

The chancellors of the university have been James Mathews, D. D., Theodore Frelinghuysen, LL. D., Isaac Ferris, D. D., LL. D., Howard Crosby, D. D., LL. D., John Hall, D. D., LL. D. Since 1885 the executive work has been devolved upon a vice-chancellor, Henry Mitchell MacCracken, D. D., LL. D.

NEZ PERCÉS, or SAHAPTINS, a tribe of American Indians, who also call themselves Numepo. The origin of the name Nez Percé (Pierced Nose) is unknown, and there is no proof of their ever having had a custom to justify it. But, like other tribes of the North-west, they practised flattening of the head of children to some extent. Lewis and Clarke in 1803 found them on the Clearwater and Lewis Rivers, and a treaty of peace then made was faithfully observed until after the admission of Oregon as a State. In 1832 Capt. Bonneville found them friendly, and in 1836 Rev. Marcus Whitman and Rev. Lyman Spaulding, being sent out by the American Board of Commissioners for Foreign Missions, established a mission among them. They were then reckoned at 4000 souls. Whitman made special effort to promote agriculture, and Mrs. Spaulding conducted a successful school. Considerable improvement has been made in their condition, and after the American Board withdrew its aid the work went on. But in the spring of 1847 trouble arose from a severe epidemic of measles, introduced by a band of white immigrants. In September Dr. Whitman was murdered by the Cayuses. The mission, which had been mainly sustained by his labors, was destroyed. Yet in 1855, when the Indians of Oregon, alarmed at the inroads of the whites, made an insurrection, the Nez Percés, who had been deprived of much of the land they claimed, remained faithful to their treaty. They saved the life of Gov. Stevens and assisted the troops under Col. Steptoe.

They were assigned a new reservation on the Lapwai River in Idaho, but those that settled here were rudely disturbed in 1859 by gold-seekers and for a time thoroughly demoralized. The Presbyterians revived the mission in Oregon and again had success in training the Indians in religion and peaceful industry (See INDIANS, AMERICAN). Others of the tribe refused to accept the treaties which reduced their reservations, and their remarkable history is given under INDIAN TERRITORY.

NIAGARA. This river flows from Lake Erie to Lake Ontario, a distance of 36 miles, in which it has a total fall of 336 feet, 52 being in the rapids above the magnificent cataract which has given it fame. The American Fall is 155 feet high and 1100 feet wide; the Horseshoe Fall 165 feet high and about 2000 feet wide. These are separated by Goat Island, which contains 62 acres. The total width of the river, including the island, is 4750 feet. The water passing over the falls every hour is estimated at 100,000,000 tons. Both the American and Horseshoe Falls are rapidly wearing away in the centre. The tendency to this in the Horseshoe Fall has been apparent for many years, but to-day the centre is in the form of a V, with the apex many rods up the stream. The American Fall has not shown such a tendency until quite recently, but now there is a well-defined V in the line, as it is seen from Luna Island. Those who have watched the recession of the falls believe that soon nearly all the water will pass through an inner channel far away from the vintor. There is also danger that the Canadian side of Goat Island may be washed away. Much of that side of the island, which is toward the former Terrapin Tower, has disappeared within a few years, and the Legislature of the State has been asked to appropriate money for the sinking of wooden cribs to prevent further erosion.

The Falls of Niagara are one hour's ride from Buffalo, twelve from New York, fourteen from Chicago. The principal village on the river is Niagara Falls, N. Y. Two miles below is Suspension Bridge. Opposite this what was formerly known as Clifton is now Niagara Falls, in the Province of Ontario. Fifteen miles to the north, at the mouth of the river, is the town of Niagara, Ontario. On the American side there is a distance of three miles between the falls and the whirlpool, but there is easy communication by horse-cars. On both sides of the river the immediate vicinity of the falls is free to all visitors.

Niagara Reservation.—The Legislature of New York in 1883 authorized the Governor to appoint five persons to be known as "The Commissioners of the State Reservation at Niagara," who were empowered to select and locate such lands as might be proper and necessary to be reserved for the purpose of preserving the scenery of the Falls of Niagara and of restoring such scenery to its natural condition. The compensation to be paid by the State to the respective property-owners, having been determined by appraisers appointed by the courts, the Legislature, in 1885, appropriated the sum of \$1,433,429.50 for the payment of the several awards. The act also provided that the lands shall be kept open and free of access without fee, charge or expense to any person for entering upon or passing to or over any part thereof. Subsequently the control and management of these lands was given to commissioners, who have power to lay out, manage, and maintain the reservation. They serve without pay, but are reimbursed for actual expenses incurred in the performance of official duties. Vacancies in the board are filled by the Governor. They are authorized to appoint a secretary and treasurer of the board. They are required to make an annual report of their proceedings, with such recommendations and suggestions as they see fit.

"The New York State Park at Niagara Falls"

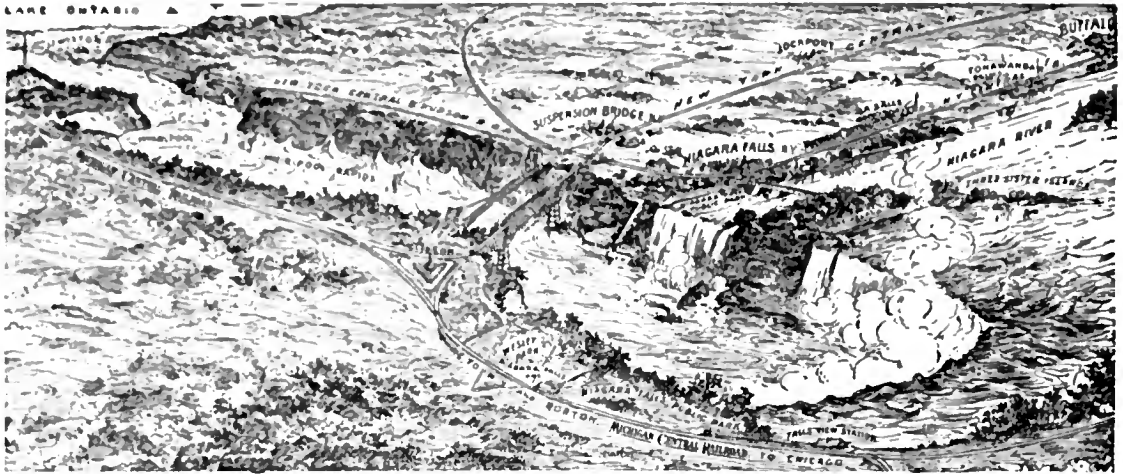

Bird's-eye View of Niagara Falls and Vicinity.

(the official title) extends along the river-front from the upper Suspension Bridge to a point nearly a mile above the falls. It also includes what was formerly known as Prospect Park, at the very edge of the American falls, and Goat Island with its group of smaller islands. The total area in the park is 115 acres. It was opened to the public July 15, 1885. While access to the grounds is free, there are small charges for using the inclined railway and the elevators, for visiting the cave of the winds, and for riding on the steamer Maid of the Mist. In the upper part of Prospect Park there has been established a reception house, a public lavatory, a bureau of advice for excursionists, including arrangements for picnics with shelters, and the office of administration. The taking of provisions upon any other part of the reservation is forbidden. The disfiguring objects have been removed from Upper Prospect Park. All along the edge of the crags a space has been prepared for people to stand upon, from twenty to thirty feet wide, and extending from the brink of the falls to the high ground back of the old wooden balcony, from all of which a line view is had of the nearer fall, the river above it, the islands, the Canadian falls, and the Ontario reservation. The surface of this standing space has been reduced to a slope with an inclination toward the falls of about 1 in 16, which allows visitors at a distance to look over the heads of those nearer the more attractive point. A balcony has been built to enlarge the available space on the projection of rock south of the wall of the inclined railroad. A new

safety cable has been placed upon the inclined railway. The electric lights have been removed from Prospect Park, and access is allowed to neither the park nor the island after dark.

Similar improvements are also to be reported upon the Canadian side of the falls. Government Commissioners surveyed and outlined the lands proposed to be taken, the area of which was about the same as that upon the American side, but the amount allowed by the arbitrators was \$978,000, or considerably less than the amount paid by the State of New York. There was so much opposition to this plan that the amount was finally reduced to \$402,000, or \$100,000 in excess of the valuation of the government. The grounds finally taken extend southward from the Clifton House for nearly two miles and include the Cedar Islands, to which an admission is charged. The Clifton House remains, but the old museum and a long line of unsightly buildings will be removed.

Bridges.—The Niagara Railway Suspension Bridge is described in the *Encyclopædia Britannica*, under BRIDGES, § 80. It was built by John A. Roebling, being commenced in 1852. The first railroad train passed over it in March, 1855. In 1886 the four stone towers which supported its cables were replaced with steel towers. The Upper Suspension Bridge, closer to the Falls, was built in 1868. It is a light, graceful structure, 1268 feet long and 200 feet above the river, which is there 190 feet deep. Originally intended for foot-passengers only, it was afterwards allowed to be used by single carriages. In 1887 it was widened to a

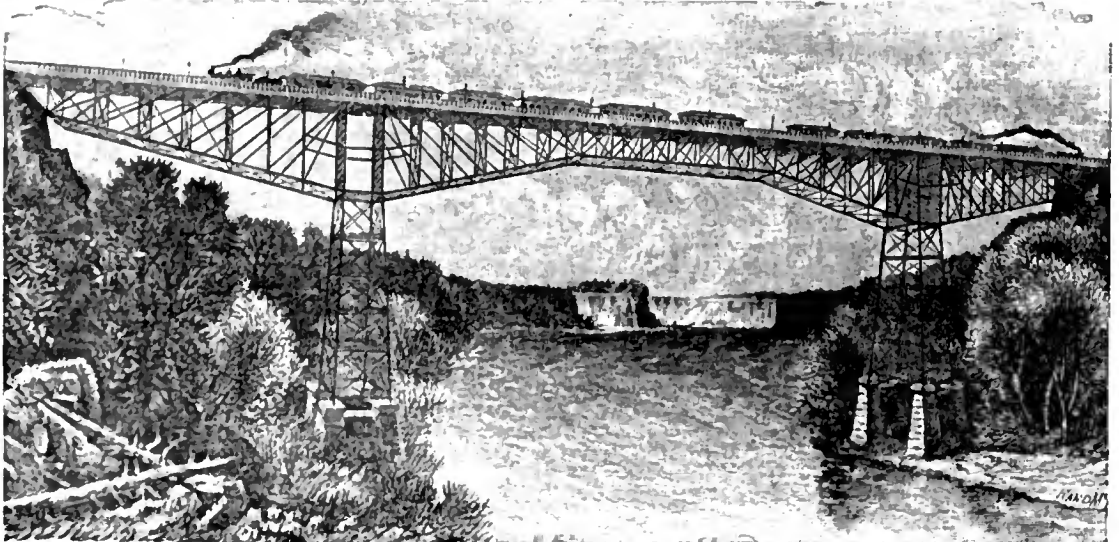

Cantilever Bridge over the Gorge at Niagara Falls.

double track; the old cables were replaced with larger ones; iron trusses took the place of wood and the towers of heavy-framed timbers gave way to towers of steel. All these changes were made without interfering with the traffic.

The still more remarkable cantilever bridge was commenced on April 5, 1883, and opened for travel on December 20 of that year. This was the earliest bridge completed upon the cantilever plan in the United States; the new bridge over the Hudson River at Poughkeepsie, the bridge over the Firth of Forth in Scotland, with a clear span of 1000 feet, and the bridge over the Fraser River, in Canada, are later examples of the same design. The bridge at Niagara Falls has a double-track railroad, and can carry upon each track at the same time a freight train of the heaviest kind, extending the entire length of the bridge, headed by two "consolidation" engines, and can withstand a side pressure of 30 pounds per square foot, which pressure is produced by wind having a velocity of 75 miles per hour. Under the above loads the structure is strained to only one-fifth of its ultimate strength. The total length of the bridge proper is 895 feet, divided into 2 cantilevers of 375 feet on the Canadian side and 395 on the American side, supported on steel towers rising from the water's edge. A fixed span of 125 feet is suspended from and connects the river arms of cantilevers; the clear span across the river is 500 feet, being the longest double-track truss span ever built. The excavations were carried down until solid rock was reached, when blocks of "béton coignet" (q. v.) 20 feet wide, 45 feet long, and 10 feet thick, were put in. These form one solid mass that will withstand a pressure almost equal to the best Quincy granite, and will so distribute the load of 1600 tons that comes upon each pair of steel columns that it will produce a pressure of but 25 pounds per square inch on the natural formation. Upon the béton blocks, 4 in number, was built masonry of the most substantial character, carried up 50 feet above the surface of the water. On these foundations the steel towers rest, rising 130 feet above the masonry, and upon these are set the steel superstructures. The material was subjected to the most rigid inspection and tests from the ore until it entered the completed structure. For erection at the bridge site temporary scaffoldings, which used some 600,000 feet of timber, were built from the bluff on either side out to the edge of the water, on a level with the top of the bluff. Upon these the shore arms of the cantilever were erected, one end resting on the steel towers and the other upon masonry on the bluff. The shore ends are anchored to this masonry, so that it will take an uplifting force of 400 tons at each end to displace it. This constitutes the counterweight to balance the unequal loading on the river arm, and as this load, under the most unfavorable conditions, can never equal 200 tons, the provision is ample. After the structure was completed from the shore to the steel towers came the difficult portion of the work—to span the 500 feet across and 245 feet above a roaring river whose forces no earthly power can stay, and no temporary structure can survive a moment. Here the skill of the engineer came in to baffle nature. The design of the cantilever was such that, after the shore arm was completed and anchored, the river arm was built out, one panel or section at a time, by means of great travelling derricks, being self-sustaining as it progressed. After one panel of 25 feet was built and had its bracing adjusted, the travelling derricks were moved forward and another panel erected. Thus the work progressed, section by section, until the ends of the cantilever were reached, when there still remained a gap of 125 feet to close. Into this was swung and suspended from the cantilever arms an ordinary truss bridge, forming the connecting link and completing the structure. Compensation for expansion and contraction was provided for by an ingenious arrangement between the ends of the cantilever and fixed span,

allowing the ends to move freely as the temperature changed, while yet preserving perfect rigidity against the side pressure from the wind. There were no guys for this purpose, as in the Suspension Bridge, but the structure was completed within itself. Neither was there any of that wave motion noticed on a suspension bridge as a train moves over. (F. G. M.)

NICCOLINI, GIOVANNI BATTISTA (1782-1861), an Italian poet, was born at the Bagni di S. Giuliano, Oct. 31, 1782. He was educated at the University of Pisa, and enjoyed the friendship of Ugo Foscolo. Several of Niccolini's tragedies were founded in Greek themes, as *Polissena*, *Medea*, *Edipo*, and he also translated from *Æschylus* the *Seren against Thebes* and the *Agamemnon*. His *Matilda* was an imitation of Home's *Douglas*. Under the government of Elisa Bonaparte he was made professor of history and mythology. His lectures and prose writings were notable contributions to Italian literature. On the downfall of Napoleon he published an allegorical tragedy, *Nabucco*. Still greater success had his *Antonio Foscarini* (1827), and his revolutionary drama, *Giorgio di Procida* (1830). *Indovino il Moro*, written about the same time, was not allowed to appear until 1847, but his *Arnaldo da Brescia*, in which he gave expression to the ardent desire of the people of Italy for religious and intellectual liberty, was printed secretly at Marseilles, in 1843. *Filippo Strozzi* (1847) contained a representation of the fallen yet not hopeless state of Italy. Among the works of his later years is the lyrical drama, *Mario e i Cimbri*. He died at Florence, Sept. 20, 1861.

NICHOL, JOHN PRINGLE (1804-1859), a Scotch astronomer, was born at Brechin, Jan. 13, 1804. He was the son of a bookseller, and studied for the ministry, but after being licensed to preach became a popular lecturer on astronomy, and was professor of practical astronomy in the University of Glasgow. He died at Rothsay, Sept. 19, 1859. Among his works are *The Architecture of the Heavens* (1838); *Contemplations of the Solar System* (1844); *The Stellar Universe* (1848); *The Planetary System* (1851); *Cyclopædia of the Physical Sciences* (1857).

His son, JOHN NICHOL, was born at Montrose, Sept. 8, 1833. He graduated at the University of Glasgow in 1855, and at Oxford in 1859. He was made professor of English literature in the University of Glasgow in 1861. He has been a popular lecturer on literature, and has contributed to the leading British views and to the *Encyclopædia Britannica*. Some of his essays were collected under the title *Fragments of Criticism* (1860). He has also published *Hannibal*, a drama (1872), *Byron* in the "English Men of Letters" series (1880); *Robert Burns* (1882). His article on *American Literature* in the *Encyclopædia Britannica* has been published separately.

NICHOLSON, ALFRED OSBORN POPE (1808-1876), Senator, was born in Williamson co., Tenn., Aug. 31, 1808. He graduated at the University of North Carolina in 1827, and after studying medicine for two years turned to law. He was admitted to the bar at Columbia, Tenn., in 1833, and was elected to Congress, where he served three terms. In 1840 he was appointed U. S. Senator on the death of Felix Grundy, and in 1843 was elected to the State Senate. In 1845 he removed to Nashville, where he edited the *Union*. In 1850 he was appointed a chancellor but held the office only one year. In 1853 he became editor of the *Union* at Washington, D. C., and soon after was chosen public printer. Returning to Columbia, in 1857 he was elected to the U. S. Senate, but retired on the secession of Tennessee in June, 1861. On account of his sympathy with the Southern Confederacy he was sent south of the Union lines, and on his return was imprisoned at Nashville. In 1870 he was a member of the State Constitutional Convention, and was also elected to the State Supreme Court, of

which he became chief-justice. He died at Columbia, Tenn., March, 1876.

NICKEL. The production of this metal in the United States is given under METALS, and its use in U. S. coins is shown under MINT. The former shows a sudden great decline in production in 1883.

This was due to the large shipments of rich nickel ores from the mines of New Caledonia, an island east of Australia, belonging to France and used as a penal colony. In 1857 M. Garnier in making a geological exploration of this island found serpentine rock with light green veins. Samples from these on being carefully examined in France proved to contain a new mineral, hydro-silicate of nickel and magnesia, which was named Garnierite in honor of the discoverer. Not until 1874 was the mineral found in large quantities. Then a vein about four feet thick was found in Mont Doré on the south side of the island, and afterwards other veins with still richer ore, said to contain about 15 per cent. of the metal. Yet the ore shipped to France in 1875 yielded only about 6 per cent. In the next year the shipments were said to be of three grades; the richest yielding 18 to 20 per cent., the second rate 12 to 15 per cent., and the poorest 6 to 8 per cent. But by far the largest amount was of the last grade. In 1883 the exports were 9024 metric tons of ore which yielded 824 tons of nickel, or about 9.13 per cent. Garnierite is found in small quantities over the whole island, but only in paying quantities in the north-west. The district believed to be richest, Bourriudi, is not yet worked. This is owing to the difficulties of access, of climate, and of labor. Water is everywhere scarce. The natives can be used only for transportation and incidental work, and easily succumb to disease, so that the hospitals are kept full and the rate of mortality is high. The French convicts are worthless as miners; the Chinese are found the best, though they require constant watching. From the Palta district in Mont Doré the ore in sacks of sixty-six pounds is carried successively on pack-horses, horse-cars, steam-railroads and scows, a distance of over 1000 miles before it reaches the steamers which take it to the island of Noumea. There it is smelted into a regulus of 60 or 70 per cent. nickel, granulated and then shipped to England. Latterly the mines at Thio have been more worked. These extend over 6000 acres, the veins vary from three to seven feet in thickness, and the average ore yields 10 per cent. The transportation from Thio is much less arduous than from the Palta district, there being more conveyance by water.

The Nickel Company of Paris now controls the production in New Caledonia, and the richness of these mines has compelled those in other countries almost entirely to suspend operations. While garnierite yields on an average nearly 10 per cent. of metallic nickel, pyrrhotite, from which nickel is obtained in Lancaster co., Pa., yields only 1.5 to 2 per cent. Although ores of nickel have been found in some other States, none have been profitably worked, or seem likely to be so. The duty on nickel imported into the United States is 30 cents a pound, but on its alloy with copper 20 cents, and foreign producers have found it practicable to make an alloy as pure as ordinary commercial nickel, and yet have it admitted at the latter rate. The price of nickel for some years has been two shillings (50 cents) a pound in London. This price is believed to be forced by the Nickel Company with a view to crushing out competition and then advancing the price. Yet in 1886 the company offered to make contracts for ten years at this rate. The American production, which in 1884 had sunk to 61,550 pounds, rose again in 1885 to 245,504 pounds, valued at \$169,398, and in 1886 was 182,345 pounds, valued at \$109,407. There were also in 1886 contributions of ore and matte amounting to 32,647 pounds, and valued at \$17,750. The price has sunk from

\$2.60 per pound in 1876 to 60 cents in 1886. The imports of nickel and its alloys in 1868 were valued at \$118,058; they afterwards decreased until in 1876 only 156 pounds, valued at \$10, were imported. Then they rose steadily, reaching in 1882 the maximum of 200,728 pounds, valued at \$143,660. In 1886 they were 159,760 pounds, valued at \$89,003.

The German Empire in 1873 adopted nickel alloy for some of its minor coins. This greatly increased the demand for the metal, and its price went up to 16 shillings, and for some years averaged 12 shillings a pound. When the supply finally had to be obtained from the French company, the German government, in 1883, gave up the use of the metal, and thus helped to cause a great fall in its price. The consumption previous to that time was estimated to be as follows: England, 500 metric tons; Germany, 300; United States, 200; France, 100; total, 1100 tons. The production in New Caledonia for the three years 1882-84 was 2400 metric tons. Finding this in excess of the demand, the Nickel Company suspended work in March, 1885, until the stock on hand should be reduced.

The French government has been considering the substitution of nickel for copper coins. The United States continue to make 5-cent and 3-cent pieces of nickel alloy. The coinage of 1885 and 1886 was as follows:

	3-cent.	5-cent.	Nickel consumed, Troy oz.
1885	4790	1,476,490	58,616
1886	4223	3,330,290	166,729

The mint at Berlin, Germany, in 1886, made nickel coinage for the Egyptian government, amounting to 12,510,210 pieces, valued at \$216,432. Nickel-plating increases slowly, and there is decided increase in the use of nickel alloys, such as white casting metal, nickel-bronze, silveroid, and other alloys which combine cheapness with hardness, durability, and good color. (J. P. L.)

NICOL, ERSKINE, a British painter, was born at Leith, Scotland, July, 1825. He was apprenticed to a house-painter, but studied at the Trustees' Academy and became a teacher of drawing. He spent some years in Dublin, where he became familiar with Irish character. He removed to London in 1862 and was made an associate of the Royal Academy in 1866. Among his pictures are Notice to Quit (1862), Waiting for the Train (1864), Both Puzzled (1866), A Disputed Boundary (1869), Steady, Johnny, Steady (1873), Paying the Rent (1876), Storm at Sea (1876), His Legal Adviser (1877), Unwillingly to School (1877), The Missing Boat (1878). His works exhibit great power of expression, both pathetic and comic.

NICOLLET, JEAN NICOLAS (1786-1843), explorer, was born at Cluses, Savoy, July 24, 1786. Having studied under the astronomer Laplace, he became secretary and librarian of the Observatory at Paris in 1817. Emigrating to the United States in 1832, he explored the Southern States, the Mississippi River, and its western affluents. He made important collections in natural history and Indian ethnology. He was sent on a second exploring tour by the War Department, Lieut. John C. Fremont being his assistant. He died at Washington, Sept. 11, 1843. His publications were chiefly on mathematical subjects.

NIGHT-HAWK, a name formerly given to the common goatsucker of Europe, *Caprimulgus europæus*, now more frequently called the nightjar, fern-owl, etc. Night-hawk has, however, become the usual name in the United States of another bird of the same family, *Caprimulgidae*, but different genus and species, namely, *Chordeiles popetue*. It is related to the Whippoorwill (*Antrastomus vociferus*) and to the chuck-will's-willow (*A. Carolinensis*), but is quite distinct from both of these birds. It may be recognized by its long, thin, pointed wings, forked tail, extremely

diminutive beak, and very wide gaping mouth not garnished with bristles. The plumage is of variegated dark colors, with a white throat-bar and white spots on the wings and tail in the male, these white marks being buff in the female. The night-hawk is found over nearly all of North America, and is commonly seen towards evening circling high in the air in pursuit of insects with a bold and buoyant flight, occasionally uttering a characteristic note. It nests on the ground and lays two dark mottled eggs. The bird is 9 or 10 inches long and nearly two feet in extent of wings. There are other species and varieties of *Chordeiles* which receive the name of night-hawk. (E. C.)



Night-Hawk.
From Coues' Check List of North American Birds.

NIGHT-HERON is the name of several different kinds of herons belonging to the family *Ardeidae*, and to the genera *Nycticorax* and *Nyctherodius*, found in most temperate and tropical countries and somewhat



Night-Heron.
From Coues' Check List of North American Birds.

nocturnal or crepuscular in their habits. The common species of Europe is *N. nycticorax* or *N. grisea*; and from this the night-heron of the United States is scarcely specifically distinct. The latter is abundant in many parts of the United States, and in some is known as the qua-bird or squawk, from its hoarse, guttural cries. It breeds on trees in swamps in large heronries, sometimes of hundreds of pairs, and lays 2 or 3 greenish eggs. The adult birds are dark glossy green on the head and back, elsewhere mostly bluish-gray or lavender, with 2 or 3 long white slender plumes springing from the back of the head. The bill is stout and the legs comparatively short. The length is about two feet, the extent 4½ feet. The yellow-crowned night-heron is *Nyctherodius violaceus*, quite distinct from the former and a more southerly bird, seldom seen even in the Middle States. It is of the same size as the former and similar in habits, but the coloration is peculiar. (E. C.)

NIGHTINGALE, FLORENCE, renowned for her services to the sick and wounded, was born at Florence, Italy, May 4, 1820. Her father, William E. Shore, a banker of Sheffield, had assumed the name Nightingale on inheriting the estate of Peter Nightingale. She was carefully educated and early showed special fondness and aptitude for nursing the sick. In 1849 she went to Germany to obtain the usual training of deaconesses in Pastor Plöbner's school at Kaiserwerth. Her description of this school published in 1859 helped

to make it widely known in England. She then took charge of an infirmary for governesses in London, but the revelation of the sufferings of the English army in the Crimea in 1854 called her to her most important work. At the request of the Secretary of War she went as superintendent of a band of female volunteer nurses, and opened a hospital at Scutari. The immediate success of her volunteer movement broke down the barriers raised by the jealousy of army officers. She was made superintendent of all the hospitals on the Bosphorus and subsequently in the Crimea. Over all the difficulties of her self-imposed task her genius triumphed and brought order out of confusion, but her health finally gave way. Returning to England in 1856, she received the thanks of the nation. Besides other marks of honor a fund of £50,000 was raised which, at her request, was devoted to founding a school of nurses under her direction. In 1862 she was commissioned by the government to examine and report upon the sanitary state of the army in India. Though precluded by the state of her health from active work, she still observes with interest the labors of others in her chosen field. She has published several handbooks, among which are *Notes on Nursing* (1850); *Notes on Hospitals* (1859); *Notes on Lying-in Institutions* (1871); and *Life or Death in India* (1874).

NIBBLISM. See BAKUNIN.

NILES, HEZEKIAH (1777-1839), journalist, was born in Chester co., Pa., Oct. 10, 1777. He became a printer and was partner in a publishing firm at Wilmington, Del., in 1800. He afterwards edited a paper at Baltimore and in 1811 he founded there the weekly *Niles' Register*, which he edited until 1836. The historical information contained in it was considered so valuable that the *Register* from 1812 to 1827 was republished in 32 volumes, and a continuation was afterwards made to June, 1849, making in all 76 volumes. Niles also published *Principles and Acts of the Revolution* (1822). He died at Wilmington, Del., April 2, 1839.

NILSSON, CHRISTINE, a Swedish vocalist, was born at Hussaby, Aug. 3, 1843, of a peasant family. Her father had charge of the music at the village church, and she early displayed great musical ability. Her violin-playing and singing at a village fair attracted Count Thorerhjelm, and by his aid she received a complete education at Stockhorn under Berwald and at Paris under Massé and Wartel. She made her debut in *Traviata* Oct. 27, 1864. She afterwards appeared in the *Magic Flute*, in *Martha*, *Don Juan*, and other operas. In 1867 she visited London and was received with great applause, appearing in *Traviata* and afterwards as Marguerite in Gounod's *Faust*. In 1868 she took part in the Handel celebration at the Crystal Palace. She came to America in September, 1870, but did not appear in opera until the following year, when she achieved a remarkable success. In July, 1872, she was married in London to Auguste Rouzaud, a French merchant. She afterwards appeared for a short season at St. Petersburg and in 1873 returned to the United States. Her husband died in 1882, and she afterwards resumed her concerts. Her voice is noted for its purity, sweetness, and flexibility. She is an excellent actress both in tragic and in comic parts.

NILSSON, SWEN (1787-1883), a Swedish naturalist and archaeologist, was born near Landsrona, March 8, 1787. He was educated at the University of Lund, and there became in 1812 instructor in natural history and afterwards overseer of the Zoological Museum. In 1828 he was placed in charge of the Museum of the Academy of Sciences at Stockholm, and after arranging this he returned in 1831 to Lund, where he was professor of zoology until 1856. He died there, Nov. 30, 1883. His principal works are *Ornithologia Suecica* (2 vols., 1817-21); *Skandinavisk Fauna* (4 vols., 1820-55), the illustrations to the latter being published separately. Other works were devoted to the mollusks,

fish, and fossils of Sweden. His most important archaeological work is *Skandinaviaska Nordens Urinnervinnare* (4 vols., 1838-43).

NINA, LORENZO (1812-1885), an Italian cardinal, was born at Recanati, May 12, 1812. He was educated at his native village and at Rome, obtaining the degree of doctor of theology. In 1835 he was ordained priest, and held various offices in the congregation of the council. Cardinal Amat made him his auditor, and Pope Pius IX. employed him on various delicate missions. He was then made assessor of the holy office, and in 1869 was a member of the commission to prepare for the council of the Vatican. He was also protonotary-apostolic and consul of the congregation of rites. He was made cardinal-deacon May 12, 1877. Pope Leo XIII. made him under-secretary of state in August, 1878. He became at the same time prefect of the palace and administrator of the property of the Holy See. He conducted important negotiations with Russia, with Germany, and with Belgium. He died at Rome, July 25, 1885.

NISARD, JEAN MARIE NAPOLÉON DESIRE (1806-1888), a French author, was born at Châtillon-sur-Seine, March 20, 1806. He studied at Sainte-Barbe, and became a journalist. In 1830 he was employed in the department of instruction. In his first important work, *Les Poètes latins de la décadence* (1834), he drew a comparison between Lucan and Victor Hugo, which led to an animated controversy with Jules Janin on romanticism and classicism. Nisard was master of conferences in French literature at the Normal School from 1835 to 1843, and meantime held various positions under the ministry until 1842, when he was elected to the chamber of deputies as a conservative. In 1843 he became professor of Latin eloquence in the Collège de France, and in 1852 he was appointed general inspector of superior instruction, and also succeeded Villemain as professor of French eloquence at the Sorbonne. In 1855 he ventured to assert that the actions of rulers are not to be judged by the rules of morality applying to private station. The consequent disturbances of the students in his room gave occasion for a public trial. In 1857 he was made director of the higher Normal School, which was then reorganized. He retired from 3^d post in 1867, when he was made senator, though he continued to be a member of the imperial council of instruction. He had been admitted to the French Academy in 1850. He died March 25, 1888. Among his publications are *Histoire de la littérature française* (4 vols., 1844-61; 6th ed., 1876); *Études sur la Renaissance* (1855); *Mélanges d'histoire et de littérature* (1868); *Les Quatre grands Historiens romains* (1874).

His brother, **MARIE EDOUARD CHARLES NISARD**, born at Châtillon-sur-Seine, Jan. 10, 1808, has done considerable literary work. From 1831 to 1848 he held a position in the household of King Louis Philippe and was connected with various journals. He was afterwards employed in the ministry of the interior. Among his publications are *Le Triumvirat littéraire au XVI^e Siècle*, namely, Scaliger, Lipsius, and Casaubon (1853); *Histoire des livres populaires* (1854); *Les Glorieux de la république des lettres* (1860); *Des Chansons populaires* (1866); *Le langage populaire ou patois de Paris* (1873). He has also edited various memoirs and historical documents.

NISBET, CHARLES. See DICKINSON COLLEGE.

NITROGLYCERINE. See EXPLOSIVES.

NOAH, MORDECAI MANUEL (1785-1851), journalist, was born at Philadelphia, July 14, 1785. He studied law and practised at Charleston, S. C. In 1811 he was made U. S. consul at Riga, Russia, and in 1813 was transferred to Tunis. On his return to America he settled at New York, where he founded and edited several newspapers, one of them being the first Sunday newspaper published there (1834). His earnest devotion to the welfare of his co-religionists was shown in 1820 in his endeavor to establish a Jewish colony on

Grand Island, in Niagara River, but the project failed. He was elected sheriff of New York, and was appointed surveyor of the port and judge of the court of sessions. He died at New York, May 22, 1851. He published *Travels in England, France, Spain, and the Barbary States* (1819); *A Translation of the Book of Jasher* (1840); *Gleanings from a Gathered Harvest* (1845), and some dramas.

NOÉ, AMÉDÉE DE, a French caricaturist, generally known by his assumed name **CHAM** (i. e., Ham, son of Noah), was the son of the Comte de Noé, and was born at Paris, Jan. 26, 1819. He early showed inclination for painting, and he received instruction from Paul Delaroche and Charlet. In 1842 his caricatures began to appear in almanacs and various periodicals. Soon they achieved great success, and were furnished chiefly to *Charivari*, but afterwards were collected in several volumes. They exhibited the ridiculous side of public events and the social life of France down nearly to 1860. After this date he published only a few vaudevilles.

NOEL, BAPTIST WRIOTHESLEY (1799-1873), an English clergyman, was born at Leightmont, Scotland, July 10, 1799. He was a brother of the first earl of Gainsborough. He graduated at Trinity College, Cambridge, in 1826, and became noted as a preacher. He was one of the queen's chaplains, and preached at St. John's, London. In 1849 he withdrew from the Established Church and became a Baptist. He was active in benevolent work among the poor. He died at London, Jan. 20, 1873. He published several volumes of sermons, some treatises on baptism and on the union of church and state.

NOLDEKE, THEODOR (1836-1875), a German Orientalist, was born at Harburg, March 2, 1836. He graduated at Göttingen in 1861, having studied under Ewald, and afterwards went to Vienna, Leyden, and Berlin. In 1864 he was made professor-extraordinary at Kiel, and in 1868 professor-ordinary. In 1872 he was called to a professorship in the newly founded University of Strasburg. He died Jan. 20, 1875. He published *Geschichte des Korans* (1860); *Des Leben Mohammeds* (1863); *Ueber die Amalekiter* (1864); *Die Alttestamentliche Literatur* (1868); *Untersuchungen zur Kritik des Alten Testaments* (1869); and *Die Inschrift des Königs Mesa von Moab* (1870). He contributed to the *ENCYCLOPEDIA BRITANNICA* on Oriental subjects.

NOMENCLATURE, GEOGRAPHICAL. The greatly varied spelling given by different writers to geographical names renders it often difficult to discover the relationship between the various spellings or to be sure whether or not two unlike words refer to the same place. The same difficulty exists in regard to biographical names. Hitherto there has been no standard of spelling in biography and geography, most travellers seeking to give to the words as pronounced by natives of foreign countries the nearest parallel sounds in the alphabet of their own language, but usually hearing and interpreting differently, so that considerable variations exist in the spelling of these names, except where long usage has given them a fixed form. Familiar examples are the two spellings Otaheite and Tahiti, which are certainly not at once recognizable as variants of the same name. The same may be said of Hawaii and Owhyhee, which would naturally be taken as names of quite different places, not as different spellings of the same name. Many instances might be given in which, though the difference is less, the lack of familiarity is more calculated to produce confusion. Numerous examples of the same kind could be drawn from the annals of biography. If we take the name of the great Mongol conqueror of the thirteenth century, it is to find it spelled by the French Djenghis or Djenguz, by the Germans Dschengis, by the English more simply Jengis or Jengiz, and by certain writers Chingis, Tehenguz, and in various other methods, this distinguished barbarian being so fortunate as to

have more than twenty different spellings to his name, besides others which are manifest errors. Similar discrepancies exist in the spellings of many other names, of which we may instance the Russian poet, Pooshkin or Pushkin in English, Pouchkine or Pouchekine in French, and Puschkin in German, and his fellow-poet, Derzhavin, Derjavine, or Derschawin. A more recent example is the Russian novelist, Toorgenev or Turgenieff.

The above examples will suffice to show the great need of a revision of method in the spelling of foreign names, and the adoption of some clearly defined system of orthography, for the use of English writers at least, if not a general system for the use of all the writers of civilized communities. Although this necessity has been long recognized, no steps of an authoritative character have been taken by biographers to produce a uniform spelling of proper names, and no generally accepted ones by geographers. Dr. Joseph Thomas says, speaking of biographical names, that there are only three courses that can possibly be pursued: "(1) To blunder over, or pronounce such names at random; (2) to endeavor to pronounce all names, foreign and English alike, according to English methods of orthography; (3) to adopt the system of pronunciation now generally recognized by the more highly educated classes in England, America, and continental Europe; that is, to pronounce all names, as nearly as possible, as they are pronounced by the well-educated people of the country to which they belong, with the exception of such names as have acquired an established English pronunciation." The third method, which he adopts as the only rational one, does not present as many difficulties in spelling as might be imagined, and could in his opinion be generally adopted with very little difficulty. All suggestions in regard to biographical spelling, however, have been personal only, and none of them carry the weight which would attach to a body of fixed rules adopted by a recognized congress of biographers.

In regard to geographical orthography, the Royal Geographical Society of England, feeling that some method of producing uniformity in spelling was seriously demanded, adopted in 1886 the following rules, which are the same as those which were previously in use in the orthography of the Admiralty charts. The high standing of the society gives its utterances and recommendations much weight, and we append its adopted rules. These rules apply only to those names which are not written in Roman characters in the countries to which they belong. In Spain, Portugal, Holland, and other countries which use Roman characters the native spelling will be preserved; nor will in any case a change be made in the spelling of names which long usage has rendered familiar to English readers. The true sound of the word, as locally pronounced, is to be taken in all cases as the basis of the spelling, but the finer inflections of sound and accent are not required to be preserved, a reasonable approximation to the sound being all that is deemed desirable.

As a general rule of orthography, vowels are to receive the Italian, consonants the English sound. No accent is to be used but the acute, and this only where it is demanded by a particular stress upon some syllable of the word. Every letter is to be sounded, and where two vowels come together each should be sounded, though sometimes so quickly as to seem but one sound, as in *ai*, *au*, and *ei*. Hindu names will be accepted as they are spelt in *Hunter's Gazetteer*. The sounds of the several letters of the alphabet are as follows:

- A as in *father*.
- E as in *benefit* or *eh*.
- I as in *machine* or English *e*. Thus *Fiji*, not *Feejee*, is the correct spelling.
- O as in *mote*.
- U as in *flute*.

All vowels are shortened in sound by doubling the following consonant. The vowel is to be doubled only when there is a distinct repetition of the sound, as in *Nuulúu*.

Ai corresponds to English *i*, as in *ice*.

Au corresponds to English *ow*, as in *how*.

Ao is slightly different from *au*, as in *Macao*.

Ei has the sound of the two Italian vowels, but is frequently slurred and resembles *ey* in *they*. Example, *Beirut*.

The consonant sounds are as follows:

B, D, L, M, N, P, R, S, T, V, W, and Z as in English.

C is to be always soft, but usually should be replaced by S, which it so closely resembles.

Ch always soft, as in *church*.

F as English *f*. Ph should not be used for *f*. Write *Huifong*, not *Haiphong*.

G is always hard. Soft *g* is given by *j*.

H is to be always pronounced when given.

J as English *j*. Dj should never be used for *j*.

K as English *k*. This letter should always be used for hard *c*. Example: *Korea*, not *Corea*.

Kh is the Oriental guttural, as in *Khan*.

Gh is another guttural, as in Turkish *dagh*, or *ghazi*.

Ng has two sounds; one as in English *finger*, the other as in English *singer*.

Q should never be used.

Qu is given as *Kw*. Example: *Kwangtung*.

Y is always a consonant, as in *yard*. It should never be used as a terminal, but be replaced by *i* or *e*.

To what extent these useful rules will be adopted is a matter to be settled by time. They may come into general use or may serve as a basis for more fully considered rules, to be chosen by some future congress of societies. At all events they mark an important step toward a highly desirable reform and may arouse those who have suffered from the annoyance of indiscriminate spelling to some decided measures of improvement in this direction. Probably the final system of geographical and biographical orthography will be one that can be applied with little or no variation by all the enlightened nations of modern time and will help towards that general linguistic conformity which is so desirable.

Another subject of importance may be noted in this connection—the superabundant nomenclature of zoological, botanical, geological, and other sciences. The species of animals and plants have been renamed so frequently by different observers that the superabundant lists of synonyms are confusing and often misleading, and it is highly desirable that some authoritative body should adopt a fixed rule of biological nomenclature which will reduce the names to a single accepted one for each species. This is being gradually done by the labors of specialists throughout the world, while varieties which have been classed as species are also being dropped, but the task is a difficult one and many years will be needed for its full accomplishment. A similar difficulty exists in the science of geology, in which the same formation bears different names in different parts of the earth, and there is a great need of a revision and simplification of the nomenclature. Important steps in this direction were taken at the London meeting of the International Geological Association in 1888, which it is to be hoped may go far to remedy the existing confusion. (C. M.)

NORDENSKJÖLD, NILS ADOLF ERIK, BARON, a Swedish Arctic explorer, was born at Helsingfors, Finland, Nov. 18, 1832. His father, Nils, was a distinguished mineralogist and took him early on exploring tours in the Ural Mountains. The son after graduating at Helsingfors, in 1857, went to Stockholm, where he was appointed professor of mineralogy. He assisted in Arctic expeditions in 1859 and 1861, and organized others in 1864 and 1868. In the last of these, conducted in a steamer, he reached on Sept. 19, 1868, a point in 81° 42' N. lat. He also thoroughly explored Spitzbergen, and on his return made known its geology, mineralogy, botany, and zoölogy. In 1870 he visited Greenland, where he found the three largest meteorites yet known. In 1872 he set out again for Spitzbergen, where he spent the winter, and in the

following spring, with a single companion, went north to the Seven Islands. His subsequent voyages and his success in accomplishing the North-East passage have been recounted under ARCTIC EXPLORATION. The results of this expedition have been published in several volumes and translated from Swedish into other languages. Besides other honors Nordenskjöld was raised to the peerage. In 1883 he again sailed for Greenland and conducted an expedition farther into the interior than had ever been done before.

NORDHOFF, CHARLES, journalist, was born at Erwitte, Prussia, Aug. 31, 1830. At an early age he was brought to the United States by his parents, who settled at Cincinnati. In 1844 he went to Philadelphia and entered the navy. He sailed around the world and served on merchant vessels until 1853, when he became a printer. In 1857 he entered upon literary work in New York, and he was connected with the *Evening Post* from 1861 to 1871, when he went to California. After a visit to Hawaii in 1873 he removed to Washington, where he has since been a special correspondent of the *New York Herald*. His publications include *Man-of-War Life* (1855); *Whaling and Fishing* (1856); *Cape Cod and all Along Shore* (1868); *Politics for Young Americans* (1875); *The Communist Societies of the United States* (1875); *The Cotton States in 1875* (1876); *God and the Future Life* (1881).

NORFOLK, a city of Virginia, in Norfolk co., is on the Elizabeth River, 8 miles from Hampton Roads, and 33 miles from the Atlantic Ocean. It has an excellent and spacious harbor. There are 2 railroads, 3 canals, and several lines of steamers connecting it with New York and other cities. Norfolk has a custom-house, a city-hall, court-house and jail, 2 national and several other banks, 28 churches, good public schools and several academies, 4 daily and 6 weekly newspapers. The city has a good water supply, is lighted with gas, and has a paid fire department. Norfolk was settled in 1705, and was made a city in 1845. It was burnt by the British in 1776. At the opening of the civil war in 1861 the U. S. navy-yard at Gosport, in the vicinity, attracted attention. It contained 12 large vessels, brought thither for repairs. When the place was threatened with capture by Virginia troops the U. S. commander deemed it necessary to destroy the vessels and the works of the navy-yard. Most of them were burnt, but the *Merrimac*, which had been scuttled and sunk, was raised by the Confederates and made an iron-clad. For its famous fight with the *Monitor*, see IRON-CLADS. Norfolk was soon after abandoned by the Confederates and remained in possession of the Union troops till the close of the war. Its commercial prosperity is now reviving.

NORMAL SCHOOLS. Normal schools are institutions for the training of teachers for the common schools. The first school of the kind was established at Rheims, in France, in 1681, by the Abbé Jean Baptist de la Salle, whose character and work have been set forth under BROTHERS OF THE CHRISTIAN SCHOOLS. But although France is entitled to the honor of having first instituted the system of normal training, Germany deserves the credit of having adopted, extended, and perfected it. The benevolent Hermann Francké (1663-1727. See sketch in the ENCYCLOPÆDIA BRITANNICA) turned his attention to the subject of popular education in the city of Hamburg. He bent all his energies toward the establishment of a teachers' seminary, in which he finally succeeded at Halle, in Prussia, about 1704; and from this institution well-qualified teachers were soon spread over all the north of Germany.

The kingdom of Prussia took the lead in the establishment of normal schools. The first normal school—in Germany called a *Pädagogium* or teachers' seminary—supported by the state was established at Stettin, in Pomerania, in 1735; the second at Potsdam, in Brandenburg, in 1748; the third at Breslau, in Silesia,

in 1765; and from the middle of the eighteenth century teachers' seminaries gradually spread all over Germany. Some of them are private institutions; but the government exercises the right of supervision over them. A brief description of the celebrated normal school of Potsdam will best explain the normal system as it exists in the different countries of Europe, for with slight deviations nearly all the European schools were modelled after it. The Potsdam Normal School and its annexed model-school or school of practice are placed under a director or principal, subordinate to the royal school-board of the province of Brandenburg, at Berlin, and to the minister of public instruction. The last-named authority lays down the principles to be followed in this school, exacts an account of all important matters, such as the examination of the masters, and any change in the fundamental plan of the studies; and receives every year, through the medium of the royal school-board, a detailed report prepared by the director of the school. The school-board is charged with the special inspection of the normal school; it must watch its progress, and from time to time send commissioners to make inquiries on the spot. It examines and approves the plan of studies presented every half year, and decides upon all questions submitted to the consistory. The director superintends the whole establishment, observes and directs the master and servants, makes reports to the superior authorities, and carries on the correspondence.

The number of pupil-teachers is fixed at from 70 to 80, and to instruct these there are 6 masters, besides the director. The conditions for admission are somewhat rigid. The candidates must be in good health, and free from all bodily infirmity; they must be 17 years old, and belong to the Evangelical religion; they must produce certificates of birth and baptism, school-certificates, and certificates of good conduct. The examination for admission is partly written and partly oral. The oral examination is confined to religion, grammar, reading, logical exercises, and arithmetic. They are examined also in singing, the piano-forte, and the violin. When a candidate passes a successful examination he is bound to sign the following engagement to the director, with the consent of his father or guardian: "I, the undersigned, M—N—, by these presents, bind myself conformably with the ordinance of the royal minister of public instruction and ecclesiastical and medical affairs to place myself during three years, after my leaving the normal school, at the disposal of the king's government, and consequently not to subscribe anything contrary to this engagement; or in such case to refund to the normal school the expenses incurred by the state for my instruction."

In the first year formal instruction predominates; in the second material instruction, and in the third practical instruction. Formal instruction consists of studies calculated to open the mind, and to inculcate on the pupils good methods in every branch, and the feeling of what is the true vocation of a primary teacher; material instruction, or more positive instruction, occupies the second year, in which the pupils go through the special studies of every solid kind, much of which they may never be called upon to teach; practical instruction, or instruction in the art of teaching, occupies the third year. In the last year the pupils are obliged to give ten well-prepared lessons a week in the model school, or school of practice. At the expiration of the three years' course the pupil-teachers are compelled to pass a rigid examination, not only in the subjects they have studied but also in the methods of teaching them.

Normal schools in Prussia are divided into public or private, superior or chief seminaries, and secondary or small seminaries. By a chief seminary was originally understood such seminaries as were completely organized according to the requirements of the laws. After-

wards they were distinguished by the fact that a special commission of examination was appointed for them, to which commission the head-teacher and the director belonged. But by a later regulation a commission for this purpose was appointed to the small, and even the private, as well as to the superior seminaries.

In 1794 a normal school was established at Paris by the national convention; but the institution was projected on a scale beyond the preparation of its earliest pupils. The instruction was mainly by lectures, delivered by such eminent scholars as Lagrange, Laplace, Sicard, Laharpe, and others, and was far above the comprehension of the immature students of the school. It was, therefore, abandoned in 1795. After the reorganization of the university, in 1806, the expediency of reviving the normal school was felt, and it was reorganized accordingly, in 1808. The number of pupils provided for by the new plan was 300; but from 1810 to 1826 there were never more than 58 in actual attendance. According to the plan of instruction, lectures were to be attended elsewhere, and interrogations and study to take place within the school under the charge of the elder pupils. The recitations of the pupils to each other were called conferences; a name which is still preserved, being applied to the lessons given by the teachers, who are called masters of conferences. The duration of the course of instruction was at first limited to two years, but subsequently extended to three. The school was a second time suppressed in 1822, and in 1826 an institution termed a preparatory school was substituted for it, which in its turn was abolished and the old normal school revived by a decree of the lieutenant-general of the kingdom, Aug. 6, 1830. A report was made by M. Cousin, Secretary of the Council of Public Instruction, in October, 1830, the recommendations of which were substantially adopted. The school then commenced a career of usefulness which has been increasing ever since.

The officers, in 1837, were the director, who did not reside at the school nor take part in the instruction; the director of studies, the resident head of the establishment; eight masters of conferences for the section of letters; six masters of conferences for the section of sciences, and one for the drawing department; two "preparers;" a sub-director, charged with the general superintendence of the pupils; and two assistants, called superintending masters. The masters of conferences have, in general, duties equivalent to those of professors in colleges. The qualifications for admission are high, and the course of instruction during the three years' course much in advance of the ordinary normal school. The Paris Normal School resembles a college with a normal department attached to it.

In 1811 the Count de Lezai Marnesia founded a normal school for primary teachers at Strasburg. The course of instruction embraced four years, and included as wide and thorough a range of studies as is now required in the best normal schools of France. According to a report of M. Guizot to the king, in 1833, it appears that the state of primary education in the two departments constituting the Academy of Strasburg was far in advance of any other section of France. Good schools were more numerous, fewer communes were destitute of schools, and the slow, defective method of individual instruction had given place to more lively and simultaneous methods of class instruction. "In all respects the superiority of the schools is striking, and the conviction of the people is as general that this superiority is mainly due to the existence of this normal school."

The establishment of 2 normal schools for the departments of Moselle and Mense, in 1820, was followed by the same results—the establishment of schools in communes before destitute and the improvement of schools already in operation, by the introduction of better methods. At the close of 1829 there were

13 normal schools in operation in different sections of France. In the three years immediately following, 34 new normal schools were established. The establishment and extension of the normal system in France and, it may be said, in Europe and America are mainly due to the exertions of Cousin and Guizot. Their investigations and writings attracted the attention of educators and statesmen in every civilized country of the world. Such was the success of these two eminent men that in 1849 there were 93 normal schools in France, including 10 institutes belonging to the Brothers of the Christian Schools, and 3 for female teachers under the auspices of an Association of Christian Education on a similar plan. After the re-establishment of the Empire by Napoleon III., obstacles were thrown in the way of the successful operation of the normal schools, and as a matter of course there followed a marked decline in their efficiency. But since the establishment of the Republic in 1871 they have been not only restored to their former good condition but have been greatly improved.

The monitorial system of teaching introduced into England by Dr. Andrew Bell (1753–1832) and Joseph Lancaster (1778–1838) was the germ of the present excellent normal system of Great Britain and Ireland. The lives and educational labors of these men have been presented under their names in the *ENCYCLOPÆDIA BRITANNICA*, to which the reader is referred. But even Bell and Lancaster had been anticipated in the monitorial or mutual help plan of teaching; for Pietro della Valle (*Il Pellegrino*), whose *Travels* in Turkey, Egypt, Persia, and India were translated into English in 1665, mentions, among the customs which he noticed in the East, the practice of children teaching one another. In 1780, according to Count Laborde, in his *Plan d'Education pour les enfans pauvres*, the mutual instruction system was, to some extent, tried by the Chevalier Paulet in France.

The monitorial system became for a time exceedingly popular in Great Britain and the United States; but it had one fatal defect: the boys and girls were too immature to avail themselves of the normal methods of the masters. Germany was the first country to abandon the system of mutual help and to press forward the establishment of normal schools. The Bell and Lancaster system, with all its faults, accomplished one great good; it opened the eyes of the British and American educators to the necessity of educating and training teachers in schools specially established for that purpose.

In 1808 the British and Foreign School Society established in London a model school and teachers' class for the "training of schoolmasters." In the beginning, its plan was very simple: it admitted a certain number of persons every year to observe, learn, and practise the methods of classification and instruction pursued there. Its accommodations as a normal school were insufficient, even on the plan of observation and practice pursued, until 1842, when a new building was completed at an expense of £21,433. In the meantime the National Society, which was more closely connected with the Church of England, was pursuing a similar plan in its model school at Westminster; and the necessity of training well-qualified teachers by means of a special course of instruction and practice was ably discussed, and the mode and results of such training as exhibited on the Continent, and especially in Prussia, were ably advocated in parliament, pamphlets, reviews, and the daily press. Lord Brougham, in his whole public life an eloquent advocate of popular education, remarked in a speech in the House of Lords in 1835, "These seminaries for training masters are an invaluable gift to mankind and lead to the indefinite improvement of education. It is this above all things we ought to labor to introduce into our system. . . . Place normal schools—seminaries for training teachers—in a few such places as London, York, Liverpool, Durham, and Exeter, and you will yearly qualify 500

persons fitted for diffusing a perfect system of instruction all over the country."

Owing to difficulties arising out of religious questions, the advocates of the normal system were unable to establish a system of national education which would provide for the training of schoolmasters. The National Society, however, erected a training college for 74 masters of schools in Chelsea, which was completed in 1812, at an expense of £23,651. At Battersea a training school was established by government officials to supply schools of industry for pauper children and reformatory schools for juvenile criminals, with properly qualified teachers, and at the same time to give an example of normal education, comprising the formation of character, the development of the intelligence, appropriate technical instruction, and the acquisition of method and practical skill in conducting an elementary school. After the methods and results had received the repeated and emphatic commendation of the Queen's inspectors, the founders transferred the institution to the management of the National Society.

The success of these experiments dissipated the prejudices against normal schools as a foreign institution, and inspired general confidence in their tendencies. The different religious denominations, which had opposed the plan of the Committee of Council in 1839, now came forward to found training colleges for teachers of schools in their several connections. In 1852 there were 31 normal schools or training colleges in England and Wales, erected at an expense of £350,000, of which the government contributed about one-half. According to the latest reports there are at present 44 of these training colleges in England and Wales.

In Scotland the first attempt to train teachers in the principles and practice of their art was made by the Education Committee of the Church of Scotland in 1826 by placing a few teachers, appointed to their schools in the Highlands, for a short course of observation, instruction, and practice in one of their best-conducted schools in Edinburgh. This plan was enlarged and improved in 1838; and in 1846 a building was erected for a normal school in Castle Place, at an expense of £10,000. In the meantime Mr. Stow, in 1836, commenced at Glasgow a similar enterprise at his own risk to train teachers on a system of instruction somewhat peculiar. The disruption of the Church of Scotland and the organization of the Free Church led to the establishment of two other normal schools, one at Edinburgh, in 1849, and the other at Glasgow, in 1852, at an aggregate expense of £20,000.

The Commissioners of National Education in Ireland have always encouraged monitorial teaching. They never contemplated, however, conducting a large school solely by monitorial assistance; nor did they ever permit their monitors to forget that they were pupils. The first regular monitors in the service of the board were those in the model schools of Dublin, as far back as March, 1833. These monitors were simply pupil-teachers receiving normal instruction in the theory and practice of teaching. There is one great normal school in Dublin, with model schools or schools of practice attached. There is also a normal agricultural school at Glasnevin. Besides these, and in connection with them, there are several model schools in different parts of the country.

The first suggestion of a normal school in the United States occurs in the *Massachusetts Magazine* for 1789, supposed to have been written by Elisha Ticknor, in which he recommends the abolition of town grammar schools and the establishment of a grammar school in each county, in which should be taught English grammar, Latin, Greek, rhetoric, geography, mathematics, etc., in order to fit young gentlemen for college and school keeping. He also recommended an able preceptor who, with a board of overseers, should annually examine young gentlemen designed for schoolmasters.

The first normal school established in the United States, avowedly for the instruction of those who desired to become teachers, was the school at Concord, Vt., instituted in 1823 by the Rev. Samuel Read Hall. For seven years he delivered a series of lectures on school-keeping and school government; and to illustrate his theories he established a model school for practice. This pioneer of American Normal Schools continued to labor in this special field until 1840—a teacher of teachers—at Concord, from 1823 to 1830; and at Andover, Mass., as principal of the Teachers' Seminary, from 1830 to 1835; and at Plymouth, N. H., from 1837 to 1840.

The first formal effort to establish a normal school in Massachusetts was made by James G. Carter, in Lancaster, in 1827, to realize the plan of such an institution which he had presented in his *Essays on Popular Education*, first published in the *Boston Patriot* in 1824-5, and afterwards issued in pamphlet form in 1826. The town of Lancaster appropriated a portion of land and the use of an academy building to aid him in carrying out the enterprise. He memorialized the Legislature for aid for a seminary for particular instruction in the science of education. The governor in his message recommended the establishment of a normal school, and a select committee made a favorable report. But the movement was in advance of public opinion as represented in the Legislature, and failed for the time being. Mr. Carter, however, continued his private normal school and turned out many excellent teachers for the district schools of New England.

In 1838, in a communication made by Hon. Horace Mann, secretary of the board of education, to the Legislature of Massachusetts, it was stated that private munificence had placed at his disposal the sum of \$10,000 to be expended under the direction of the board for qualifying teachers for the common schools, on condition that the Legislature would place in the hands of the board an equal sum to be expended for the same purpose. Resolutions were passed accepting the proposition and authorizing the governor to draw his warrant for \$10,000 for the purpose specified. Mr. Mann, who had previously made himself familiar with the workings of the normal system in Europe, took a most active part in the establishment of the State normal schools.

After mature deliberation the board decided to establish three normal schools, one for the north-eastern, one for the south-eastern, and one for the western part of the State. Accordingly one was opened on the 3d of July, 1839, at Lexington; but the school outgrew its accommodations and was removed to West Newton in the same county, in 1844, and afterwards to Framingham in 1853. The second normal school was opened at Barré, Sept. 4, 1839. This school has since been removed to Westfield on account of the insufficiency of the accommodations at Barré. The third normal school was opened at Bridgewater on the 9th of September, 1840, and has never changed its location. The school at Framingham is appropriated exclusively to females; and those at Bridgewater and Westfield admit both sexes.

As most of the normal schools of the United States have been modelled, to a great extent, on the plan of the Massachusetts State normal schools, just as the latter were, as far as feasible, modelled on the plan of the Prussian schools, a statement of the course of study adopted for the three new schools will give a fair idea of the breadth and scope of the instruction.

The Course of Study.—The studies first attended to in the State normal schools are those which the law requires to be taught in the district schools, namely: orthography, reading, writing, English grammar, geography, and arithmetic. When these are mastered those of a higher order are progressively taken. For those who remain longer than one year the following course was arranged:

(1) Orthography, reading, grammar, composition,

rhetoric, and logic. (2) Writing and drawing. (3) Arithmetic (mental and written), algebra, geometry, book-keeping, navigation, and surveying. (4) Geography (ancient and modern), with chronology, statistics, and general history. (5) Human physiology and hygiene or the laws of health. (6) Mental philosophy. (7) Music. (8) Constitutional history of Massachusetts and of the United States. (9) Natural philosophy and astronomy. (10) Natural history. (11) The principles of piety and morality common to all sects of Christians. (12) The science and art of teaching with reference to all the above-named studies. Religious exercises: A portion of the Scriptures is required to be read daily in every State normal school.

In addition to the three State normal schools already mentioned another was established in 1854 at Salem; another, in 1870, at Cambridge; and another, in 1874, at Worcester. Besides these there is a city normal school in Boston, instituted in 1852.

Among the earliest and most earnest advocates of legislative provision for the professional training of teachers stands the name of Gov. De Witt Clinton. In his message to the Legislature of New York, in 1825, he recommended to their consideration the education of competent teachers; and again in the next year he said: "I therefore recommend a seminary for the education of teachers in those useful branches of knowledge which are proper to engraft on elementary attainments." In his message of 1828 he again urged the subject on the attention of the Legislature. Through the efforts of John C. Spencer and Gen. John A. Dix, the Board of Regents of the University of New York, in May, 1834, were authorized to apply a part of the income to the literature fund to the education of common-school teachers. Again, in 1836, the State Superintendent, Gen. Dix, adverted to the fact that in the adoption of this system the Legislature has merely provided for the more complete execution of a design long contemplated so far as respects the employment of the academies for normal school purposes. He stated in his report that "the propriety of founding separate institutions upon the model of the seminaries for teachers in Prussia was for several years a subject of public discussion in this State."

The Committee on Colleges, Academies, and Common Schools made a report to the Legislature of New York, in 1844, in which it was recommended to establish a normal school in Albany. By means of a sub-committee the committee had examined the normal schools of Massachusetts and inquired into their operations in other countries. The recommendation of the committee was adopted by an almost unanimous vote, and \$9600 was appropriated for the first year and \$10,000 annually for five years thereafter in appropriations for the support of the school. The city of Albany tendered the use of a suitable building, free of rent, and the school was organized and commenced the business of instruction December, 1844. Since the establishment of the first normal school at Albany the following State normal schools have been instituted: One at Oswego in 1861, one at Brockport in 1867, one at Fredonia in 1868, one at Cortland and one at Potsdam in 1869, one at Geneseo and one at Buffalo in 1871. There is also a training school in connection with the high-school at Syracuse. In addition to these nine normal schools the city of New York supports at an annual expense of \$100,000 a normal college for the education of female teachers, which is, perhaps, the largest and best equipped institution of the kind in the United States. It has a large school of practice attached to it, and the grounds and buildings are estimated to be worth at least a million of dollars. The college was established in 1870, mainly owing to the efforts of Mr. William Wood, who, as commissioner, in his visits to the common schools, saw the necessity of educating teachers for their highly important work.

From Massachusetts and New York the normal

system has gradually spread all over the United States, until there were, in 1886, 117 public normal schools, with 1115 instructors and 31,801 students. Ninety-six of these are supported by the States and 21 by the cities. There were also, in 1886, 36 private normal schools, with 279 instructors and 8524 students. These schools are distributed among the States and Territories as follows:

States.	Public.	Private.	States.	Public.	Private.
Alabama.....	6	2	Nebraska.....	2	1
Arkansas.....	1	1	New Hampshire...	2	0
California.....	3	2	New Jersey.....	3	1
Colorado.....	1	1	New York.....	11	0
Connecticut.....	1	0	North Carolina....	5	1
Florida.....	1	0	South Carolina....	1	3
Georgia.....	0	0	Ohio.....	5	1
Illinois.....	3	2	Oregon.....	1	0
Indiana.....	3	5	Pennsylvania.....	11	2
Iowa.....	3	2	Rhode Island.....	1	0
Kansas.....	1	1	Tennessee.....	1	4
Kentucky.....	0	4	Texas.....	1	2
Louisiana.....	2	2	Vermont.....	3	0
Maine.....	5	4	Virginia.....	4	0
Maryland.....	2	0	West Virginia....	6	0
Massachusetts.....	10	0	Wisconsin.....	5	2
Michigan.....	1	0	Dakota.....	2	0
Minnesota.....	3	0	Dist. of Columbia.	2	0
Mississippi.....	1	3	Utah.....	0	0
Missouri.....	1	0	Washington.....	1	0

See H. Barnard's *Journal of Education*; Dr. James Phillips Kay's *Report to the British Parliament* on the "Prussian System of Teachers' Seminaries;" Guizot's *Report*, as Minister of Public Instruction in France, on the Normal Schools of Prussia; the *Report of the Prussian System to the Massachusetts Board* by Dr. Julius, of Hanburg; Horace Mann's *Report to the Massachusetts Legislature on the Establishment of Normal Schools*; the Messages of Gov. De Witt Clinton recommending the Normal System; A. D. Bache's *Report on the Normal Schools of France and Germany*; the *Reports of U. S. Commissioner of Education*. (T. H.)

NORRISTOWN, a borough of Pennsylvania, county-seat of Montgomery co., is on the east bank of the Schuylkill River, 16 miles N. W. of Philadelphia, with which it is connected by the Reading and Schuylkill Valley Railroads. It is a handsome town, built on hills. It has a fine marble court-house, opera-house, public library, jail, 2 national banks, 1 other bank, 15 churches, Treemount Seminary, and several public schools. The industrial works comprise rolling-mills, foundries, cotton- and woollen-mills, glass-works, tack-factory, flour-mills, etc. Two daily and 5 weekly newspapers are published here. The State Asylum for the Insane for the Eastern District is located here. On the west side of the river is the borough of Bridgeport, with which Norristown is connected by three bridges. Population of Norristown in 1880 was 13,063; of Bridgeport, 1802.

NORTH ADAMS, a manufacturing village of Berkshire co., Mass., is on the Hoosac River, at the west end of the Hoosac Tunnel, 36 miles E. of Albany. This tunnel, perforated through the Hoosac Mountains, is 5 miles long and is owned by the State. It is used jointly by 5 railroads, which pass through North Adams and connect it with Troy and Albany on the west and Boston and other cities on the east. North Adams has 8 hotels, 2 national and 2 other banks, 3 weekly newspapers, 9 churches, graded schools and academies. The industries comprise 1 foundry, 4 woollen- and 7 cotton-mills, 8 shoe-factories, 2 print-cloth-factories, and other manufactures. The village is picturesque in situation, being surrounded by high hills and beautiful scenery. It has gas- and water-

works. Its property is valued at \$5,500,000: its public debt is \$80,000, and the yearly expenses \$119,000. Its population in 1880 was 10,191, but a local census in 1886 gave 14,250.

NORTHAMPTON, a city of Massachusetts, shire-town of Hampshire co., is on the W. bank of the Connecticut River, 17 miles N. of Springfield and 80 miles W. of Boston. Three railroads pass through it, and there is also a street railway to Florence. The city has excellent water-works, electric lights, and a fire department. There are 3 national and 3 savings banks; 10 churches and 2 newspaper offices. A stream affords abundant water-power which is utilized in manufacturing paper, silk, and cotton goods. Other manufactures are cutlery, sewing-machines, brushes, etc. Besides the State Lunatic Asylum Northampton contains the Clarke institute for deaf-mutes, the John Clarke library with 20,000 volumes, the Smith Charities, and Smith College (*q. v.*), an institution for the higher education of women.

NORTH CAROLINA. There has been no official

census taken since 1880. See Vol. XVII. p. 558 (p. 572 Am. Rep.).

The population of the State in 1888 is probably 1,800,000. There is but little emigration from the State. The immigration, mainly from the Northern and North-western States, more than balances the losses. Some of the cities and towns have increased rapidly in numbers and wealth. The following table shows the growth of the most prominent:



	1888.	1880.
Raleigh	15,800	9,265
Wilmington.....	23,000	17,350
Charlotte.....	12,000	7,054
Asheville.....	10,000	2,616
Winston and Salem	10,000	4,194
Durham	7,500	2,041
Fayetteville.....	6,000	3,485
Goldsboro	6,000	3,286
Greensboro	6,000	2,005
Reidsville.....	5,000	1,316
Henderson.....	5,000	1,421

The public charitable and penal institutions of the State are in good condition and well managed. There are three asylums for the insane—one at Raleigh, one at Morganton, both for whites only, and one at Goldsboro for the colored. That at Raleigh, Eugene Grissom, M. D., LL. D., superintendent, has 290 patients. It cost \$250,000. The Western North Carolina Asylum cost \$150,000 and has 420 patients; superintendent, Dr. P. L. Murphy. The Eastern North Carolina Asylum, Dr. J. M. Miller, superintendent, for the colored only, cost \$78,000. It now contains 196 patients. The total number of insane in the State, including harmless incurables, is estimated at about 3000. The asylums for the blind, deaf, and dumb are at Raleigh, one for the white and the other for the colored, both under Mr. W. J. Young, superintendent. The former has 76 deaf and dumb, and 59 blind; the latter 30 deaf and dumb, and 23 blind. The buildings cost about \$100,000. The penitentiary is unfinished. It has 1471 convicts, of whom 184 are within the walls, the remainder on outside works, mainly constructing railroads. The State aids the Oxford Orphan Asylum by annual grant of \$10,000. It has 210 orphans and is under the charge of the Masonic fraternity.

In addition to a building purchased for the agricultural department, which contains its museum and State chemical laboratory, the State has recently erected a structure for the public library and Supreme Court rooms, and also a maunson for the use of the governor.

The Western North Carolina Insane Asylum and

the Eastern North Carolina Insane Asylum have also recently been completed. The State University has likewise added about \$40,000 of new structures, consisting of laboratories and a capacious auditorium. The United States has since 1880 completed new courts and post-offices at Raleigh and Greensboro, and others at Wilmington, Asheville, and Charlotte are to be commenced at once.

Finances.—The valuation of real property in the State for taxation is \$126,883,382; personal property, \$75,561,351; total, \$202,444,733, an increase over 1880 of \$46,344,551. The rate of taxation is 20 cents on the \$100 value for State purposes, other than educational. The total amount of taxes for the State on property, licenses, etc., is \$560,369. Total amount for the counties is \$920,077. In addition to this \$605,203 is raised for school purposes.

The compromise offered by the State in regard to the public debt has been accepted by most of its recognized creditors and has reduced the acknowledged debt to \$6,404,511. The interest of \$2,795,000 of this is provided for by dividends of the railroad stock, for which bonds were issued, leaving \$3,609,511 bearing 4 per cent. interest to be paid by taxation. This does not include a large amount (about \$20,000,000) of "special tax bonds," which have been repudiated by constitutional amendment as fraudulent. The capital of the national banks of the State is \$2,312,280, and they issue only \$795,710 of circulating notes. The individual deposits are \$2,928,300.

Manufactures.—In the absence of official returns only partial statistics can be given of the progress of the State in manufactures. The latest estimates show 80 cotton-factories, operating 4671 looms and 199,433 spindles. They have more than doubled since the census of 1880. The tobacco-factories have largely increased also. A considerable number of establishments for the manufacture of furniture, spokes, handles, and other wood-work have sprung up. There are hopeful indications that the extensive water-power of the State and other advantages for manufacturing are to be utilized. The forests of oak, cherry, walnut, white and spruce pine, and poplar, in the mountain section, are being cut by lumbermen from the North and North-west, and largely exported. A topographic survey has been made by the U. S. Geological Survey, and it is ascertained that deposits of valuable minerals and ores exist in large quantities. The mountain-sides are admirably adapted to the growth of fruits and the grasses. Nearly 7000 square miles of rich territory, heretofore almost unknown, now invite emigration.

Agriculture.—The principal farming products of the State in 1887 were as follows: Indian corn, 35,830,000 bushels; wheat, 5,094,000; oats, 8,504,000; tobacco (in 1886), 31,559,000 pounds; cotton, 1,066,000 acres; production about 420,000 bales, estimated. Of live-stock there were: Horses, 149,708; mules, 89,945; milk-cows, 243,715; oxen and other cattle, 419,383; sheep, 427,560; swine, 1,266,438. There has been much improvement in the way of introduction of fine breeds of cattle and horses, the establishment of stock-and dairy-farms, the purchase of labor-saving machinery, the increase of acres devoted to grasses, the adoption of the intensive system of farming, and the use of home-made fertilizers. Much of this improvement has been caused by intelligent work of the agricultural department, including the fertilizer control and experiment station, which by analysis of fertilizers and dissemination of information concerning their constituents, and by furnishing formulas for home-made manures, have done much towards enlightening the people. An experiment-farm has recently been opened, and extensive experiments promoted. The importance of the work of the agricultural department may be inferred from the fact that prior to its establishment there were 125 brands of fertilizers sold in the State, of which 80 have been driven out on account of their inferiority, and the remainder greatly improved. The

cost of fertilizers in 1887 was 25 per cent. less than in 1880, while the quality improved 14 per cent. The phosphate-beds of the State have been explored and mapped, and, though inferior to those of South Carolina, will hereafter be a source of wealth. The marls of the State have been analyzed and their use increased. The establishment of fertilizer-factories has been stimulated, there now being nine. The pyrites-deposits of the State have been explored and samples analyzed. Analyses for the board of health have been made of drinking-water and other substances, and noxious ingredients ascertained.

An exploration of the coal-fields of the State has been made under authority of the board, and a report published by Dr. H. M. Chance. A report was likewise published in *Mining in North Carolina*, by Dr. George B. Hanna. Under the direction of Lieut. Winslow, U. S. N., the oyster-beds in the extensive sounds and inlets of the coast have been explored and mapped, and a comprehensive report of the same published. Under Mr. S. G. Worth, Fish Commissioner, hatcheries have been operated for increasing the supply of shad, herring, rock, and other fish in North Carolina waters. Under Mr. J. L. Patrick, Commissioner of Emigration, valuable publications have been made and distributed for the purpose of making known the resources of the State. Other publications under authority of the board are: *A Description of the Minerals and Mineral Deposits of North Carolina*, by F. A. Genth and W. C. Kerr, the latter being the late State geologist; hand-books and bulletins, containing miscellaneous information about the State, published in 1883 and 1886; *Annual Reports and Bulletins* of the agricultural experiment-station, from 1877 to 1887; *Report on the Ores of North Carolina*, by W. C. Kerr and G. B. Hanna, 1887, being chapter II. of Kerr's *Geology of North Carolina*, vol. II., now in progress of publication, under the editorial supervision of Prof. Joseph A. Holmes. It may here be noted that since the death of Prof. Kerr the State geological work has been discontinued.

The activity of the farming class is shown by the increase of county and district agricultural societies, and by the rapid spread of the society called the Farmers' Alliance. There are 1198 organizations, with about 50,000 members. L. L. Polk is president of the Inter-State Farmers' Association. The grangers have also an organization, W. R. Williams being master.

By act of the General Assembly of 1887 a bureau of labor statistics has been created. The commissioner, Mr. W. U. Jones, has made a report, giving valuable but incomplete information on the subject.

Climate.—Much attention has been recently directed to parts of North Carolina as health-resorts. The territory on both flanks of the Blue Ridge, and the sand-hills in the southern middle section, are considered favorable for the cure of pulmonary diseases, and are much resorted to for the purpose. The mountains and the sea-coast are likewise attracting many summer visitors on account of the beautiful scenery and pleasant climate of the former, and sea-breezes and surf-bathing of the latter.

Railroads.—A marked impetus has since 1880 been given to the development of the State by branch railroads, connecting with the main lines. These main lines are: 1. The Richmond and Danville system, running through the State by way of Greensboro and Charlotte, from north to south, and by way of Salisbury and Asheville into Tennessee. 2. The Atlantic Coast Line system, bisecting the eastern half of the State, by way of Weldon and Wilmington. 3. The Seaboard Air Line system, running from Norfolk by way of Raleigh, and now building an extension to Atlanta. The first has recently added to its system 11 branches, aggregating 308 miles finished, and is constructing 130 more. The Atlantic Coast Line has finished 227 miles of branch roads, and is building 55 in

addition. The Seaboard Air Line has finished 166 miles. Other important new lines are the Cape Fear and Yadkin Valley, extending from a point on the Norfolk and Western Railroad, west of the Blue Ridge, to Wilmington, of which 130 miles are completed; the Charleston, Cumberland Gap, and Cincinnati Railroad, of which about 75 miles will be in the mountain and Piedmont district of North Carolina; the Carolina, Knoxville, and Cumberland Gap Railroad, of which there will be about 60 miles in the mountain regions. The total mileage of finished railroads may be stated at 2450, with 550 in process of construction. Other lines in addition are projected, with fair prospects of success.

Education.—The public school system is still embarrassed by the loss of the school-fund during the civil war, and by the poverty of the people. The constitution of the State does not permit taxes for general purposes higher than \$2 on the poll, and 66 $\frac{2}{3}$ cents on the \$100 value of property. As the valuation of property is low, it is impossible at present to provide by taxation for keeping the schools open for the proper length of time. The total amount of money collected for 1887 from this source chiefly was \$647,407. The school-property is valued at \$634,356. The number of whites who attended in 1887 was 202,134; the number of colored, 123,145. The number of children of school age is 353,481 white, 212,781 colored. There are 8 normal schools for whites in different parts of the State, held during the summer for from 3 to 5 weeks each. There are 5 normal schools for the colored, lasting from 8 to 10 months. Excellent graded schools, supported by special city taxation, are in Wilmington, Goldsboro, Raleigh, Durham, Fayetteville, Winston, Salisbury, Charlotte, and Asheville. The State has devoted the public swamp-lands to the school-fund. Recent surveys show that there are from 600,000 to 700,000 acres of these lands, some of which are of great intrinsic value; but the expense of draining them is so great that they cannot be brought extensively into market until the other lands of the State greatly appreciate. The board of education is engaged now in cutting canals for drainage and building roads through these swamps.

The State University turns out annually many teachers for the schools of the State. Good service in this regard is likewise rendered by Davidson, Wake Forest, Trinity, and other denominational colleges, and by the best of the high-schools. These colleges, as well as the university, have conspicuously increased their endowments, corps of professors, and apparatus for instruction, and are constantly increasing their patronage. There are also in the State many classical schools of the highest rank, some of them drawing their patronage from distant States. Notwithstanding these aids to higher education, parts of the State are deficient in good schools. In this connection should be mentioned a strong demand for industrial education. This has culminated in the establishment of an agricultural and mechanical college, the buildings of which are now being erected at Raleigh. It is contemplated that all the students of this college shall regularly be employed at manual labor, while carrying on a course of theoretical study.

Sea-Ports.—The harbor of Wilmington, on the lower Cape Fear, has been much improved by the United States, so that now vessels drawing 18 to 20 feet can come to its wharves. This, with its early connection with the railroads of the North-west, by the completion of the Cape Fear and Yadkin Valley Railroad, will bring prosperity to this city. Some work has been done under the authority of the general government in various rivers and inlets of the State; but there is a deficiency of good harbors, which drives its products to markets beyond its borders.

North Carolina has been making steady progress in recent years, and its natural resources, its orderly population, its singularly agreeable and healthful cli-

mate, and its proximity to the great centres of population and wealth of the North Atlantic, should insure a marked advance in prosperity. (K. p. u.)

NORTH CAROLINA, UNIVERSITY OF. The constitution of North Carolina directed the establishment of a university, and a charter was accordingly granted, Dec. 11, 1789, to forty corporators, the first being Gov. Samuel Johnson. A supplemental act bestowed on the institution all arrears due to the State from receiving officers up to Jan. 1, 1783, and all escheated property. Unclaimed land-warrants granted to soldiers of the Revolution were located in Tennessee, and its General Assembly allowed to the University of North Carolina title to one-third. The trustees met at Fayetteville, Dec. 15, 1790, and chose Gen. Wm. Lenoir (1751-1839) president. In November, 1792, a committee selected New Hope Chapel Hill as the site for the university, 1280 acres there having been offered as a donation. The village was marked out and the corner-stone of the first university building laid by Gov. W. Richardson Davie, on Oct. 12, 1793. Chapel Hill is 12 miles south of Hillsborough, the county-seat of Orange, and 28 miles W. N. W. of Raleigh. Gov. Benjamin Smith in 1790 had given a warrant for 20,000 acres of land in Tennessee, which was sold about 1837 for \$14,000. In 1797 Gen. Thomas Person gave \$1025 for the completion of the "Old Chapel" or "Person Hall," and others subscribed \$7648 for the erection of buildings. A loan of \$10,000 from the General Assembly was afterwards made a gift.

At the opening of the university in 1795 David Kerr, a graduate of Trinity College, Dublin, was made professor of ancient languages, and Charles W. Harris, a graduate of Princeton College, professor of mathematics. A year later Rev. Joseph Caldwell, D. D., LL. D., succeeded the latter in his professorship and in 1804 was made president. He held that position until his death in 1835, with the exception of the years 1812-16, during which time Rev. Dr. Robert H. Chapman, of Virginia, was president. In 1809-10 sundry citizens subscribed about \$10,535 for the erection of buildings. David L. Swain, LL. D., who had been governor of the State from 1832 to 1835, then became president of the university, and remained in office till 1868. Under his direction the university had at the outbreak of the civil war nearly 500 students. It was the only Southern institution of its rank that continued its exercises throughout the war. The escheated land-warrants had after many years realized for the university about \$150,000, but this amount was lost during the civil war by the insolvency of the bank in whose stock it was invested. Other smaller sums had been received from time to time from escheats in North Carolina, arrears, confiscations, etc., amounting in all to \$134,000, which had been used for buildings and current expenses. The United States by the act of 1862 gave to the State for the establishment of a college of agriculture and the mechanic arts land-scrip for 270,000 acres. This was sold in 1867 at the market price of 50 cents per acre, but the investment of the funds proved unfortunate.

On the adoption of the State constitution of 1868, during the reconstruction period, the faculty of the university was displaced by a new corps, of which Rev. Solomon Pool was president, but no exercises were held after 1870. In 1875, in pursuance of a constitutional amendment, new trustees were elected by the General Assembly, and a new faculty was installed, with Rev. Charles Phillips, D. D., LL. D., as presiding professor. In 1876 Kemp P. Battle, LL. D., who had formerly been State treasurer, was elected president, and has since discharged the duties of that office. By his efforts about \$18,000 had been given by citizens for the revival of the university. The State also gave a certificate for \$125,000, on which 6 per cent. was paid semi-annually. Hon. B. F. Moore, of Raleigh, bequeathed in 1878 the sum of \$5000, the interest of which is to be applied to defraying the uni-

tion of students. Rev. Charles F. Deems, D. D., of New York, formerly a professor in the university, established in 1880 a fund to aid indigent students, and Mr. W. H. Vanderbilt increased this fund, which now amounts to \$13,000. In 1885 Miss Mary Ruffin Smith, residing near Chapel Hill, bequeathed to the university a plantation in Chatham co., called Jones' Grove, and valued at \$15,000. The rent of the property, or interest on the proceeds, if the property be sold, is to be applied by the faculty in the education of suitable students. Mrs. C. P. Spencer, daughter of Rev. Dr. James Phillips, presented to the university 1000 volumes from his library.

Government.—The university is by the State constitution entrusted to the General Assembly. That body has committed it to 80 trustees, who are usually chosen from different sections of the State. They hold office for eight years, one-fourth being chosen every two years. The governor is *ex officio* president of the board, though not necessarily a member. Ten members constitute a quorum. At the annual meeting, held in January, an executive committee of seven trustees is appointed, who hold office for one year and have all the power not expressly forbidden by the board. As these are elected on account of convenient access to the city of Raleigh, continuity of wise and efficient management is secured. The offices of secretary and treasurer are combined, and this officer now, Hon. W. L. Saunders, secretary of state, resides in Raleigh, and is a member of the executive committee.

The Faculty consists of the president, professors, and assistant professors, their votes being equal. The president is a member of the board of trustees, whose communications with the board go through him. Although his powers have never been defined by law, courtesy and custom concede to him sufficient authority.

Among the best known members of the faculty of the past have been Presidents Caldwell and Swain, Ethan A. Allen and Denison Olmsted, afterwards of Yale University, Dr. Wm. Hooper, Dr. Elisha Mitchell, who lost his life in exploring the mountain named from him, the highest peak of the Alleghanies, Rev. Dr. James and Charles Phillips, professors of mathematics, Walker Anderson, afterwards Chief-Justice of Florida, Dr. Wm. M. Green, afterwards Bishop of Mississippi, Dr. Charles F. Deems, now of the Church of the Strangers, New York, Nicholas M. Hentz, Rev. Dr. F. M. Hubbard, Wm. H. Battle, LL. D., Judge of the Supreme Court of North Carolina, B. F. Hedrick.

Under Prof. Olmsted, in 1824, was organized the geological survey of the State, believed to be the first in the Union by public authority. In 1831 Pres. Caldwell built the first astronomical observatory in this country, but its operations were discontinued after his death in 1835.

The university has been of great service to public-school education by successful inauguration of summer normal schools, now common in the South. A great impetus was thereby given to the training of teachers, and the establishment of graded schools.

Instruction.—Originally Latin, Greek, and mathematics were the studies principally attended to. This system continued uninterrupted until January, 1854, when a school was established for the "application of science to arts," with Dr. Charles Phillips as professor of civil engineering, and Benjamin F. Hedrick as professor of agricultural chemistry.

In 1875 the university was reorganized on the basis of largely increased liberty of election and much greater proportion of scientific and linguistic studies. Three courses lead to degrees; one to that of bachelor of arts (A. B.), including both Latin and Greek; another to that of bachelor of philosophy (Ph. B.), with Latin or Greek replaced by French or German; and the third replacing both the classics with French, German, and scientific studies, leading to the degree of bachelor of science (S. B.). Besides these, students are allowed to

take an optional course, leading to no degree, but in number of hours employed equivalent to the regular courses. The classical course is "the old curriculum," but with a larger proportion of scientific studies. The degrees of doctor of philosophy (Ph. D.), master of arts (A. M.), and master of science (M. S.), are conferred upon students who have completed post-graduate studies prescribed by the faculty. The first (Ph. D.) requires the equivalent of two years' study in two departments, and the others the equivalent of one year's study in three departments. A course in law leads to the degree of bachelor of law (B. L.).

In 1881 the General Assembly appropriated \$5000 per annum, and in 1885 \$15,000 per annum in addition, so that the university had an income of \$27,500 per annum, besides tuition fees. The trustees were thus enabled to add seven more professorships. In 1887 the General Assembly concluding to establish a separate agricultural and mechanical college, took away the land-scrip fund, yielding \$7500 a year, and it became necessary to abolish three of the professorships. Its faculty now consists of fifteen professors and assistants.

A special course of three months is offered, each spring, to teachers who desire to extend their education. The general studies of special benefit to farmers, merchants, manufacturers, and other business men, have been grouped into a small course of two years, for the benefit of students who are unable to complete a full course. For students of medicine there is a short course of two years, comprising such general studies as are essential to the education of a physician, and such special studies in chemistry, botany, zoölogy, physiology, etc., as are included in the curriculum of all medical colleges. No diploma is granted.

Societies.—In connection with the university are the Dialectic and Philanthropic Literary Societies, to one of which each student is required to attach himself, unless excused for special reasons. The halls of these societies are commodious and elegantly furnished. The Elisha Mitchell Scientific Society was established in October, 1883. Its aim is to stimulate individual workers, and to enable the members to keep up with the growth of science. It is a State society, and includes among its members all scientific workers in the State. The students are allowed all the advantages of the society. A semi-annual journal is published, containing accounts of the meetings and all original papers. Over 500 pages have thus been published. This journal is exchanged for the publications of more than 100 other learned bodies and scientific societies. Occasional lectures on popular scientific subjects are delivered by resident members of the society and lecturers invited from a distance.

A Shakspeare Club was organized in November, 1886, for the critical study of Shakspeare and other dramatists.

The North Carolina Historical Society is engaged in the study of State history and the collection of documents and material for its illustration. Meetings, as a rule, are held monthly.

A Seminary of Literature and Philology has been formed for the benefit of students who feel a special interest in literary work; and to promote research along special lines with more thoroughness and individuality than is possible in the class-room. The professors in the several departments of the university, besides guiding and assisting in the regular work of the seminary, present from time to time the results of their own special labors. At each meeting reports are made concerning new publications, new theories, and methods, new achievements in every department of literary work.

The University Magazine is published six times during the year, under the auspices of the Philanthropic and Dialectic Societies.

There is a branch of the Young Men's Christian Association among the students. It has many members of spirit and activity, and its influence for good is very marked.

Museums.—Every scientific department of the university is equipped with a museum of specimens for laboratory work; and besides these working museums there is a large and valuable collection of specimens in botany, geology, mineralogy, zoölogy, and entomology, carefully arranged for exhibition in the university museum.

Libraries.—The Philanthropic and Dialectic University Libraries have been consolidated and carefully arranged in Smith Hall. The consolidated library is open daily, except Sunday, for the use of students. It contains 25,000 volumes and 5000 pamphlets, illustrating every department of literature and science.

Lectures.—In addition to the lectures presented before the Mitchell Scientific Society, the Shakspeare Club, and the Historical Society, the university sustains a course of public lectures.

Campus and Buildings.—The campus is a fine grove of old forest trees, chiefly oak and hickory, fifty acres enclosed, beautifully undulating. Adjoining are about 500 acres of woodland, belonging to the university. The buildings of the university are nine in number, affording ample accommodation in the way of dormitories, lecture-halls, laboratories, etc. (K. P. B.)

NORTHCOTE, SIR STAFFORD HENRY (1818-1887), became Earl of Iddlesleigh about two years before his death. He was born at London, Oct. 27, 1818, and was educated at Eton and Balliol College, Oxford. He was private secretary to Mr. Gladstone when the latter was president of the Board of Trade, 1843-45. He was called to the bar in 1847 and was one of the secretaries of the World's Fair at London in 1851. On the death of his father in that year he became the eighth baronet. The investigation of the civil service next occupied his attention, and in 1854, with Sir Charles E. Trevelyan, he made a report which was the basis of the subsequent reform opening all the lower offices to competitive examination. In 1855 his parliamentary career began. As a Conservative he represented Dudley until 1858, then Stamford until 1866, and then North Devon until 1885, when he took his seat in the House of Lords. He was financial secretary to the treasury, 1856-59; president of the Board of Trade under Lord Derby, 1866-67; secretary of state for India, 1867-68. The Conservatives then retiring, Lord Northcote was made governor of the Hudson Bay Company. In 1871 he was a member of the High Joint Commission on the Alabama Claims at Washington.

In March, 1874, when the Conservative party returned to power under Disraeli, Lord Northcote became chancellor of the exchequer. He had learned financial management from Mr. Gladstone and was the most successful of the Conservative leaders in this department. His administration was marked by the extinction of the sugar-duties and the establishment of an effective sinking-fund. Disraeli being elevated to the peerage, Lord Northcote became the Conservative leader in the House of Commons. He was noted for his conciliatory disposition and affable manners. While he won the favor of his opponents he did not always gratify the desire of his partisans. In 1880 the Liberals again had a majority in the House and Northcote remained leader of the opposition until 1885. When Mr. Gladstone was defeated in that year Lord Iddlesleigh, having just succeeded to his title, entered Lord Salisbury's ministry as first Lord of the Treasury. He was thrown out a few months later, but in 1886, when Lord Salisbury returned to power through the change caused by Mr. Gladstone's espousing the Irish demand for Home Rule, Lord Iddlesleigh was made secretary of state for foreign affairs. He died suddenly in London, Jan. 12, 1887. He had published several speeches on financial and political topics, and *Twenty Years of Financial Policy, 1842-61* (1862). As Lord Rector of the University of Edinburgh he delivered an interesting address on *Desultory Reading* (1886).

NORTH-WESTERN UNIVERSITY. This institution of learning, at Evanston, Ill., obtained its charter Jan. 28, 1851. Its founders, chiefly citizens of Chicago, intended to establish an institution devoted to the interests of Christian learning under the patronage of the Methodist Episcopal Church. On June 14, 1851, the trustees organized, and resolved to open a preparatory school in Chicago. Rev. Clark T. Hinman, D. D., LL. D., was elected the first president, June 23, 1853, after the trustees had decided to open an institution of higher grade. The site having been unanimously selected, a purchase was made, of 379 acres of land, for \$25,000. A town including this tract of land was organized in 1857, and called Evanston, in honor of John Evans, M. D. Subsequently, large additions were made to the land of the university.

Several amendments were made to the original charter, the most important of which enacted that "no spirituous, vinous, or fermented liquors shall be sold, under license or otherwise, within four miles of the location of said university, except for medicinal, mechanical, and sacramental purposes, under a penalty of \$25 for each offence, to be recovered before any justice of the peace of said county of Cook." The village therefore enjoys a high reputation for morality and sobriety. It was also declared that all property of the university should be exempt from taxation. Upon this point in 1873 commenced a bitter contest between the town and the management of the Northwestern University. After two unsuccessful appeals to the Supreme Court of the State a writ of error was taken to the U. S. Supreme Court. The decision of the lower court, which was unfavorable to the university, was reversed, and the property of the university was held to be exempt from taxation. By the charter the corporation is not allowed "to hold more than 2000 acres of land at any one time, unless the said corporation shall have received the same by gift, grant, or devise, and in such case it shall be required to sell or dispose of the same within ten years from the time they shall acquire such title, and on failure to do so such lands, over and above the before-named 2000 acres, shall revert to the original donor, grantor, deviser, or their heirs."

The land owned by the university was laid out for a village, with streets and house-lots; parks were reserved, lots were donated to churches, and Evanston soon became a popular place of residence. With the avails received from the sale of lots the debt of the university was paid, and a fund secured for the erection of University Hall. The university was opened to students in 1856. Dr. Hinman had died in June, 1855, and his successor, Rev. Randolph S. Foster, D. D., LL. D., was appointed president June 5, 1856. The other members of the faculty were Rev. Abel Stevens, LL. D., Henry S. Noyes, A. M., Rev. W. D. Godman, and Daniel Bonbright, LL. D. Literary, scientific, and elective courses, of four years each, were established. In the meantime a small wooden structure had been completed, and was occupied by the university. The building is still standing, having been removed from its original site, and with an addition is now occupied by the preparatory department of the university. The classes in the university were transferred to a large and commodious building of stone, costing \$110,000. About this time the university adopted as a part of its permanent policy a rule that one-fourth of all lands then held by it in the town of Evanston, and all owned in Chicago, should be reserved from sale and be leased, and the funds received from the remainder that should be sold should be converted into productive property and held as a permanent fund.

President Foster having resigned his office in 1860, Henry S. Noyes, A. M., professor of mathematics, became acting president of the university, holding the office for six years thereafter. Rev. Erastus O. Haven, D. D., LL. D., was elected president, and assumed

the duties of his office June 23, 1869. About this time important additions were made to the educational facilities of the university. The Chicago Medical College, which had been organized for ten years, became a department of the university, and during this year the university classes were opened for the admission of women. This movement was a preliminary step to the adoption, in 1873, of the Evanston College for ladies, as a part of the institution.

Dr. Haven having resigned his office, in October, 1872, Rev. Charles H. Fowler, D. D., LL. D., became its president. In June, 1873, the Union College of Law became a department of the university. At this time was created the College of Technology, or School of Applied Sciences, the students in which were given the use of the now extensive museum, drawing-room, and laboratories, in which to pursue their scientific studies and investigations. Photography and telegraphy were also taught, both in theory and practice. Subsequently, because of economical considerations, this department of the university was discontinued. Of the presidents named, Drs. Foster, Haven, and Fowler became bishops of the Methodist Episcopal Church. In 1876 Prof. Oliver Marcy, LL. D., became acting president, and held this office till 1881, when Rev. Joseph Cummings, D. D., LL. D., the present incumbent, became president.

The university has been greatly prospered and its funds have been largely increased. The land purchased in Chicago for \$8000, from which an annual rental of \$8000 has been received since 1880, is now worth \$800,000. By the terms of the lease a new appraisal is to be made every ten years, and the next appraisal will be made in April, 1890. By the conditions of the lease the university will receive 7½ per cent. of the appraised value, and after the next appraisal its income will be very largely increased. The university still holds, for lease or for sale, lots in Evanston of the value of \$500,000. The property of the university is estimated to be worth about \$2,000,000. In all departments it has 100 professors and instructors, and more than 1300 students.

The following departments of the university are now organized: 1. The College of Liberal Arts, which has four regular courses of study, and opportunities for a select course. 2. The College of Medicine, Nathan S. Davis, M. D., LL. D., dean. 3. The College of Law, Henry Booth, LL. D., dean. 4. The College of Pharmacy, Oscar Oldberg, Ph. D., dean. 5. The College of Oral and Dental Surgery, John S. Marshall, M. D., dean. 6. The Dearborn Observatory, George W. Hough, director. 7. The Preparatory School, Rev. Herbert F. Fisk, D. D., principal. 8. The School of Elocution, Robert L. Cumnock, A. M., director. 9. The Conservatory of Music, Oren E. Locke, director. 10. Department of Art, Catharine Beal, B. P., director.

Located on the university grounds and closely connected with it are the Garrett Biblical Institute, Rev. Henry B. Ridgway, D. D., president; also the Swedish Theological Seminary, Rev. Albert Ericson, A. M., president; and the Danish and Norwegian Theological Seminary, Rev. N. E. Simonson, A. M., president. There is an interchange of privileges between the university and these theological schools, and each one derives all the advantages from the others that could be secured in any other relation that might exist.

The Woman's College is a large and elegant building that gives the young women the advantages of a well-regulated home. Miss Rena A. Michaels, Ph. D., is dean. There is also a college cottage, which offers special advantages to young women of limited means.

The colleges of medicine, of law, of pharmacy, and of dental and oral surgery are in Chicago, and the other departments are in Evanston.

The university has always maintained a preparatory school, graduating annually a class of 60 or more stu-

dents, with a faculty of 10 instructors. While it meets the requirements of the best colleges of the country, there is also provision for a general academic education for students who wish to prepare themselves for the study of medicine, law, teaching in the public schools, or for business.

A large and well-furnished Hall of Science, recently erected on the college campus, affords good accommodations for the departments of chemistry and physics. Practical instruction is given in the laboratories in this building in the departments of chemistry and physics.

The Dearborn Observatory, connected with the university, makes original researches in astronomical science, assists in the application of astronomy to geography, in communicating exact time, and furnishes instruction in astronomy to the students of the university. The principal instruments of the observatory are: 1. An equatorial refracting telescope, made by Alvan Clark & Sons, of Cambridge, Mass., in 1861. The instrument was the largest refractor in the world until a few years ago, and now has very few superiors. Diameter of object glass, 18½ inches. 2. A meridian circle, of the first class, constructed in 1867 by Messrs. A. Repsold & Sons, of Hamburg. This instrument has a telescope of 6 French inches aperture, and a divided circle of 40 inches diameter, read by 4 microscopes. Hough's printing and recording chronographs have been added, for making an electrical record of the time of star transits. (J. C.)

NORTON, ANDREWS (1786-1853). Unitarian minister, descended from the Puritan Rev. John Norton (q. v.), was born at Hingham, Mass., Dec. 31, 1786. He graduated at Harvard College in 1804, and was made tutor at Bowdoin College in 1809 and at Harvard in 1811. Becoming librarian in 1813 he succeeded Rev. Dr. W. E. Channing as lecturer on Biblical criticism and interpretation. In 1819 he was made Dexter professor of sacred literature, which position he resigned in 1830. He afterwards published *A Statement of Reasons for not believing the Doctrines of Trinitarians concerning the Nature of God and the Person of Christ* (1833). His important work on *The Genuineness of the Gospels* (4 vols., 1837-55), and his new *Translation of the Gospels* (1855), occupied most of the remainder of his life. He died at Newport, R. I., Sept. 18, 1853. He was one of the most learned Unitarians. He studied the New Testament with a critical yet reverent spirit, and opposed the extreme naturalistic interpretation. After his death his *Statement of Reasons* was republished with a memoir by Dr. W. Newell. Besides the works above mentioned he contributed important articles to the *North American Review* and other periodicals, and composed some hymns which have been widely used.

His son, CHARLES ELIOT NORTON, was born at Cambridge, Mass., Nov. 16, 1827. He graduated at Harvard College in 1846, and entered upon a mercantile life. He sailed to India in 1849 and returned by way of Europe. He afterwards made two other lengthy sojourns in Europe. He has published *Considerations of some Recent Social Theories* (1853); *Notes of Travel and Study in Italy* (1860); a translation of Dante's *Vita Nuova* (1867); and *Historical Studies of Church Building in the Middle Ages*. Besides editing his father's later works he was joint editor of the *North American Review* from 1864 to 1868, and contributed to the *Atlantic Monthly*.

NORTON, JOHN (1606-1663). Puritan divine, was born at Stortford, England, May 6, 1606. He was educated at Cambridge, was curate at Stortford, and became a Puritan. In 1635 he removed to Plymouth, Mass., where he preached during the winter and then became minister of the church at Ipswich. He took part in forming the Cambridge Platform in 1648, and in 1652 became associate minister of the church at Boston, where he was urgent in the persecution of the Quakers. After the restoration of Charles II. Norton was sent with Gov. Bradstreet to

London to assure the king of the loyalty of Massachusetts, but the result was not satisfactory to the people. Soon after his return Norton died at Boston, April 5, 1663. His most noted publication was *The Heart of New England rent by the Blasphemies of the Present Generation* (1659), a treatise against the Quakers. He also published a memoir of Rev. John Cotton (1658), and some theological treatises.

NORTON, WILLIAM EDWARD, painter, was born at Boston, June 28, 1843. He was apprenticed to a housepainter, but at the age of 18 went to sea, and after making several voyages began painting marine views in 1865. He went to Europe in 1877 and opened a studio in London. Among his works are *Whaleships Trying Out, Fog on the Grand Banks, Twilight on the Banks of Newfoundland, Nantasket Beach* in November.

NORWALK, a borough of Connecticut, and township of Fairfield co., is on Long Island Sound, 42 miles from New York city, on the New York, New Haven, and Boston Railroad, and is the terminus of the Danbury and Norwalk Railroad. It has a good harbor, 5 hotels, 5 national banks, 2 opera-houses, Masonic temple, 2 large boarding-schools, besides public schools, 10 churches, and 7 weekly newspapers. The oyster trade is extensive, and manufactures are largely carried on. Besides the largest straw-hat-factory in America, Norwalk has 7 fur-hat-factories and 3 shoe-factories. There are also 4 foundries, large iron-works, a lock-factory, several woollen- and grain-mills, and other manufacturing establishments. Norwalk was founded in 1649. Being ardently patriotic in the revolutionary war, it was burned by Gov. Tryon in 1779. In 1852 a terrible railroad accident was caused here by an open draw-bridge. The township of Norwalk, about ten miles square, includes the city of South Norwalk as well as the borough of Norwalk. The latter has gas- and water-works and several parks. Many wealthy inhabitants of New York make this a summer residence, and during the winter flowers are sent in abundance to the metropolis. Population of Norwalk, 5308; South Norwalk, 3726; township, 13,956.

NORWALK, a village of Ohio, county-seat of Huron co., is on the Lake Shore and Michigan Southern Railroad, 56 miles W. S. W. of Cleveland. The Wheeling and Lake Erie Railroad also passes through the village. It is built on a sandy ridge and has well-paved, shady streets. There are 2 national banks, 14 churches, graded schools, railroad machine-shops, and manufactories of ploughs, organs, sewing-machines, shoes, tobacco, etc. The population in 1880 was 5704.

NORWICH, a city of Connecticut, the county-seat of New London co., is at the head of Thames River, 15 miles from Long Island Sound. It is on the Norwich and Worcester and the New London and Northern Railroads. It has several hotels, 6 national banks, 3 savings banks, 1 daily and 2 weekly newspapers, 24 churches, graded schools, and the Norwich Free Academy. The Thames River is formed by the confluence of three streams, which furnish abundant water-power. This has been utilized in large paper-, cotton-, and woollen-mills, and there are several foundries and works for making the machinery used in these. There are also manufactories of wood-type, files, locks, picture-cords, belts, and pistols. The city is lighted with gas and electricity, has water-works, 2 public squares, and street railways. The town was settled in 1659. In 1880 the population of the city was 15,112 and of the township 21,143.

NOTT, ABRAHAM (1767-1830), judge, was born at Saybrook, Conn., in 1767. He graduated at Yale College in 1787, and, after a brief study of theology, went to Georgia to teach school. He studied law at Camden, S. C., and was admitted to the bar in 1791. He served one term in Congress, 1799-1801, and in 1810 was elected a judge of the court of appeals. He died at Fairfield, S. C., June 19, 1830.

His son, HENRY JUNIUS NOTT (1797-1837), grad-

uated at South Carolina College in 1814, was admitted to the bar in 1818, and was professor of logic and philosophy in his *Alma Mater* for thirteen years. While returning from New York he was drowned off the coast of North Carolina, Oct. 13, 1837. He published *Novellets of a Traveller* (2 vols., 1834).

Another son, JOSTAH CLARK NOTT (1804-1873), ethnologist, was born at Columbia, S. C., March 31, 1804. He graduated at South Carolina College in 1824, and obtained the degree of M. D. in Philadelphia in 1827. After acting as demonstrator of anatomy to Dr. Physick for two years, he began practice at Columbia, S. C. In 1835 he went to Europe, and after his return settled at Mobile. In 1857 he was made professor of anatomy in the University of Louisiana, and in 1858 established a medical college at Mobile which received an endowment from the State of Alabama. He died at Mobile, March 31, 1873. He published *Biblical and Physical History of Man* (1849); *Physical History of the Jewish Race* (1850); *Types of Mankind* (1854); and *Indigenous Races of the Earth* (1857), being assisted in the last two by G. R. Gliddon. He held the theory of a diverse origin of the several races of mankind and the inferiority of the negro.

Another son, GUSTAVUS ADOLPHUS NOTT (1810-1875), became professor of anatomy in the University of Louisiana in 1839, and materia medica and therapeutics in 1848. He was a surgeon in the Confederate army. He died at Montgomery, Ala., June 6, 1875.

NOTT, ELIPHALET (1773-1866), president of Union College, was born at Ashford, Conn., June 25, 1773. He graduated at Brown University in 1795 and became pastor of a Presbyterian church and principal of an academy at Cherry Valley, N. Y. In 1798 he removed to Albany, where he acquired celebrity as a pulpit orator. His sermon on the death of Alexander Hamilton is one of the most famous specimens of American pulpit eloquence. In 1804 he was elected president of Union College, Schenectady, N. Y., which was then a feeble institution with only 14 students; but under his judicious management it increased steadily in numbers and usefulness. In 1854 the semi-centennial anniversary of his inauguration was celebrated with great enthusiasm by over 600 graduates. Altogether more than 3700 students graduated in his presidency. Towards the end of his life he was relieved to some extent of the duties of his office. He had also been prominent in church affairs, and in 1811 was moderator of the Presbyterian General Assembly. Besides taking much interest in natural science he made several useful inventions. His noteworthy improvements in stoves caused them to be generally used instead of open hearths for heating dwellings. Philanthropic movements, and especially the temperance cause, enlisted his services. After a long life spent in active beneficence, he died at Schenectady, N. Y., Jan. 29, 1866. Among his publications are *Counsels to Young Men* (1810); *Lectures on Temperance* (1847); *Resurrection of Christ* (1872). His *Memoirs* were published by H. Van Santvoord (1876).

His brother, SAMUEL NOTT, D. D. (1754-1852), was born at Saybrook, Conn., Jan. 23, 1754. He graduated at Yale College in 1780 and became pastor of the Congregational church at Fairfield, Conn., in 1782. Here he labored for seventy years, until his death, May 26, 1852.

SAMUEL NOTT (1788-1869), son of the preceding, graduated at Union College in 1808 and at Andover Theological Seminary in 1819. Being ordained Feb. 6, 1812, he was sent as missionary to India by the American Board of Commissioners of Foreign Missions. On account of ill health he returned in 1816, and taught in New York until 1822. He afterwards held pastorates at Galway, N. Y., and Wareham, Mass. At the latter in 1849 he founded an academy which he conducted until 1858. He died at Hartford, Conn., June 1, 1869. He published *Slavery and the Remedy* (1850).

NOYES, GEORGE RAPALL (1798-1868), Biblical scholar, was born at Newburyport, Mass., March 6, 1798. He graduated at Harvard College in 1818 and studied theology at Cambridge Divinity-School. He was licensed to preach in 1822 and held pastorates at Brookfield and at Petersham, Mass. In 1840 he was made professor of Hebrew and Oriental languages and Dexter lecturer on Biblical literature. Besides many reviews and sermons he published new translations, with notes, of several books of the Old Testament. After his death his translation of the New Testament from Tischendorf's text was edited by Dr. Ezra Abbot (1868). He died at Cambridge, Mass., June 3, 1868.

NOYES, JOHN HUMPHREY (1811-1886), communist, was born at Brattleboro, Vt., Sept. 3, 1811. He graduated at Dartmouth College in 1830, studied theology at Andover and New Haven, and was licensed to preach in 1833. A year later he began to advocate "perfectionism," and his license was revoked. In 1838 he established a communistic society at Putney, Vt., and in 1847 removed it to Madison co., N. Y., where it was called the Oneida Community, for which see ENCYCLOPEDIA BRITANNICA. A second community was established at Wallingford, Conn. In 1882 the people of Oneida county became thoroughly roused against the immoral practices prevailing in the Community and obtained power from the Legislature to stop them. The members then renounced their obnoxious practices and formed a business corporation. Noyes published some periodicals, of which the *Oneida Circular* was the chief. He also published *The Bazaar*, *Salvation from Sin*, *Bible Communism*, *History of American Socialisms*. He died at Niagara Falls, Canada, April 13, 1886.

NUBAR PASHA, an Egyptian statesman, was born at Smyrna in January, 1825, of an Armenian Christian family. He was early taken to Europe and educated in Switzerland and France. In 1842 he went to Egypt to become secretary of Bogos-Bey, a relative, who was then minister of foreign affairs. Two years later he became secretary-interpreter to Mehemet Ali and afterwards to Ibrahim Pasha. His influence steadily increased, and Abbas Pasha, in 1850, sent him to London to support the claims of Egypt against Turkey, and also on other diplomatic missions. Under Said Pasha (1854-63), though not always in favor, he was able to construct the railroad from Suez to Cairo, in spite of great natural and financial difficulties. Ismail Pasha employed Nubar as his agent with the Sultan, and thus obtained various important concessions. His next negotiations were at Paris with reference to the Suez Canal, and on his return to Egypt he was made minister of the public works. Towards the end of 1866 he was made minister of foreign affairs, and, having gone to Constantinople, he obtained from the Sultan for his master the title of Khedive, while Egypt was made practically independent. Nubar Pasha's efforts were then directed to introducing European customs into the administration of affairs. He was driven from power in May, 1874, but was restored a year later. Again removed early in 1876, he did not return until England and France had intervened and required a complete reconstruction of the financial affairs in favor of the bondholders of Western Europe. Nubar Pasha became president of the cabinet Aug. 23, 1878, but the discontent of the native Egyptians with the new methods of taxation and administration obliged him to resign six months later and even to leave the country for a time. During the revolt of ARABI PASHA (*q. v.*) and the English intervention, Nubar Pasha remained quiet. At last, on Jan. 8, 1884, he was called again to the head of affairs, and his administration has been favorable to the interests of the British government, and yet more acceptable to the Egyptians than formerly.

NUISANCE. American law has closely followed the English in defining this term and prescribing the

remedy. It may be added here that the locality has much to do with the question what constitutes a nuisance. People living in populous manufacturing towns must expect more noise, smoke, and disturbance than those living elsewhere; consequently a manufactory which might be a nuisance if situated entirely among residences would not necessarily be so in such a town. The following are some instances of public nuisances: The bathing in a public river in sight of the neighboring houses; rude or riotous games or sports, involving a breach of the peace; the keeping of a disorderly or gaming house; keeping a dangerous animal, known to be such, and suffering him to go at large; exposing a person having a contagious disease in public; the bringing a horse infected with glanders into a public place; the selling tainted or unwholesome food; the leaving a corpse unburied; the storing of combustible articles in undue quantities or in improper places. Private nuisances may be either to corporeal hereditaments, *e. g.*, the building of a house so as to throw the rain-water on the adjoining tenement; or to incorporeal hereditaments, *e. g.*, obstructing a right of way, interfering with a franchise, etc.

Annoyances from odors, smoke, unhealthy exhalations, noise, etc., are in the nature of private nuisances and will be restrained by injunction at the instance of the person injured. An action for damages will also lie in such cases. (T. R.)

NULLIFICATION. This term, as used in the history of the United States, refers to the public acts of South Carolina, declaring certain acts of Congress to be in excess of the constitutional authority of that body, and therefore void of efficacy, and commanding her citizens to refrain from yielding obedience to them.

On May 19, 1828, an act of Congress was passed imposing duties upon certain commodities imported into the United States from foreign countries. Acts of a similar character, previously passed by Congress, to meet certain exigencies, financial and commercial, had not encountered resistance in any of the States. During the discussion of this act it was characterized in several of the States, notably in South Carolina, as intended distinctly for the protection of domestic manufactures. The Legislature of South Carolina had in 1825 declared "that it is an unconstitutional exercise of power on the part of Congress to lay duties to protect domestic manufactures."

The discussions attending the action of the Legislature just referred to disclose the origin of the opposition to protective legislation, in part, in its inconsistency with the views of the national Constitution that prevailed in that State, as in others of the Southern group, and, in part, in the nature and condition of the productive industry of that section, that was then regarded as excluding the development of manufactures. The production to which South Carolina looked as the basis of her economic system and to which her institutions and laws were conformed was that of cotton, the staple of the largest existing manufactures, for which the principal markets were European, and the necessities of cotton-planting appeared to those engaged in it to demand the perpetuation of legal slavery as the only form in which labor could be applied to that industry under existing climatic conditions. The cotton-planting interest considered that the industrial development of the respective groups of States, Northern and Southern, must disclose divergences of interest and policy, widening with the growth of the country, that could not be harmonized under a government unitizing these groups. Viewed from the same standpoint it seemed a necessity, not only that the domestic institutions of the cotton-producing States should be entirely free from the influence of other communities differently situated, but that the commercial intercourse between the great staple producer and the best markets of the world

should be free from conflicting interests. These prudential considerations were fully recognized in the Legislature of South Carolina and indicate the state of interests that formulated a political policy tending to deny to the government of the United States a national character and to subject it to a controlling power held in reserve not only by groups of States united in interest, but by individual States, to be exercised as their views of their own interest might suggest. The policy that thus connected itself with the cotton interest had preceded the development of that industry, having relation to other staples produced in the Southern section of the Union, and was brought into a distinct statement by the Kentucky and Virginia Resolutions of 1798 and 1799. This doctrine, as advanced by those resolutions and subsequently applied in the attempt of South Carolina to nullify the revenue laws of the United States, is considered in another place under STATES RIGHTS.

As stated in the legislative records of South Carolina, discussing the right to nullify the action of Congress, that doctrine involves several distinct propositions which will be briefly noted. The Constitution was regarded as a compact between sovereign States, and not as an organic act of the peoples of the States uniting in the Constitution of a government of the whole; certain agencies were thereby created as the common agencies of the sovereign parties to the compact, and the powers and duties of such agencies specifically defined, so as to exclude any enlargement thereof by implication, such as could be made if the fundamental intention was the production of a sovereign government; the allegiance of the citizens of the States was regarded as wholly due to their respective State governments, and capable of being claimed by the general government only through the assent of such States; the legislative, executive, and judicial departments of the government of the United States were regarded as functions depending upon the assent of the sovereign States, and could not be exercised to control the source from which their authority was derived; that any State could, consistently with the compact, retire from it whenever, in its judgment, the powers conferred were abusively exercised to the prejudice of its honor or its interests.

From the premises just stated it was concluded that as the power to promote manufactures by means of imposts on foreign goods was not among the enumerated powers specifically conferred upon Congress, it was not capable of being exercised, and the attempt to exercise it on the part of Congress was an assumption of powers that belonged to the States, and accordingly that it was competent for any one of the States to refuse to allow the execution of such laws within its territories, or, if that course was deemed desirable, to retire from the union of the States.

On Dec. 19, 1827, the Legislature of South Carolina reiterated the declaration of 1825, as above stated. This action was upon an elaborate report of a Senate committee declaring that such usurpation of authority by Congress must be resisted by the States in their sovereign character, and was not proper for submission to the judiciary of the United States.

After the passage of the act of 1828, and on Dec. 19 of that year, the Legislature of that State protested against the act on the broad ground before affirmed, and already stated, and directed such resolutions to be communicated to the governors of the respective States, to be laid before their respective Legislatures, to determine on such ulterior measures as they may think the occasion demands. Such communication took place and was responded to by Virginia and Georgia in terms approving the general views of South Carolina as to the limitations of the authority of Congress, but indicating unwillingness to sanction the attitude of hostility assumed by South Carolina towards the United States.

On Dec. 17, 1830, the Legislature of South Carolina

declared that the several acts of Congress imposing duties upon imports for the protection of domestic manufactures are deliberate and highly dangerous and oppressive violations of the Constitution, and that it is the right of any State suffering thereby, after all hope of redress is lost, to interpose in its sovereign capacity for the purpose of arresting the progress of the evils occasioned by such unconstitutional acts.

On June 14, 1832, Pres. Jackson sent a letter to citizens of Charleston, by whom he had been invited to unite with them in commemorating independence on the ensuing 1th of July. This letter was mild and conciliatory in its general tone, but contained the following sentence, that was the only expression contained in it that indicated the intended attitude of the administration. He says, speaking of the circumstances that should be weighed in the existing state of affairs: "But he should also see that high and sacred duties, which must and will at all hazards be performed, present an insuperable barrier to the success of any plan of disorganization, by whatever patriotic name it may be decorated, or whatever high feelings may be arrayed in support of it." On Dec. 17, 1831, the Legislature of South Carolina declared that the letter of Pres. Jackson was to be regarded as an official utterance, and, as such, "is an unauthorized interference in the affairs of this State; that the principles advanced in it are incompatible with the Constitution, and subversive of the rights of the State; that the threatened course of executive conduct would, if acted upon, destroy the liberties of the country, and as a threat is a dangerous precedent, highly repulsive to the feelings of a free people." The report on which this action was based distinctly assumes the ground that a State has the right to withdraw from the Union, and is the sole judge of the sufficiency of the ground for so doing, this right being stated as inherent in the compact of the States.

Congress, in 1832, repealed the act of 1828 and re-adjusted a tariff of duties, to take effect from March 3, 1833.

On Oct. 26, 1832, the Legislature of South Carolina called a convention of the State to take into consideration the acts of Congress imposing duties on foreign imports for the protection of domestic manufactures, to determine their character and means of redress; also any amendment of, or substitute for, such acts that Congress may enact; also all laws for executing and enforcing the same.

The convention met, and on Nov. 24, 1832, adopted an ordinance "to nullify certain acts of the Congress of the United States purporting to be laws laying duties and imposts on the importation of foreign commodities." After reciting that the object of these laws was for the protection of domestic manufactures, and characterizing them as oppressive and unconstitutional, it declares that the acts of 1828 and 1832 are unauthorized by the Constitution and are null and void, with all obligations, acts, and judicial proceedings intended for their enforcement. It declares unlawful any attempt to enforce the collection of such duties by any officer of the State or of the United States, and enjoins upon the Legislature the passage of acts to enforce this ordinance. It declares that there shall be no appeal from any judgment denying the validity of such acts of Congress, and that no record in any such case shall be transmitted to the appellate court, but the courts of the State shall proceed to execute any such judgment notwithstanding any such appeals, and the taking of such an appeal shall be regarded as a contempt of the court. It further requires an oath to support this ordinance to be taken by all public officers and jurors. Finally, it declares that if any attempt should be made by the federal government to coerce the State, they will hold themselves absolved from all further obligations to maintain or preserve their political connection with the people of the other States, but will organize a separate government. Upon the adop-

tion of this ordinance the convention issued an address to the several States of the Union setting forth its action and the grounds on which it was based.

On Dec. 10, 1832, Pres. Jackson issued a proclamation reciting the ordinance of South Carolina and the grounds on which it was placed, and characterizing it as an act of nullification and secession, and declared it unconstitutional. He states that as the opposition to the laws had clothed itself with State authority, an exposition of the views of the administration was appropriate. He holds that the only appeals from the action of Congress, recognized by the Constitution, are to the judiciary, the people, and the States, and that as the Constitution is the supreme law of the land no State can annul a law. He claims that the declaration that the law was intended for the protection of domestic manufactures, and therefore was unconstitutional, goes to the motives that prompted the law and not to the authority by which it was passed, and is a dangerous construction. He holds that the government of the United States is a national government, and not merely a league; that to the extent of the grant of power to Congress the States parted with their sovereignty, and the allegiance of their citizens was, to that extent, transferred to the national government. He exhorts the people of South Carolina to yield obedience to the law, and finally declares his determination "to execute the laws, to preserve the Union by all constitutional means, to arrest, if possible, by moderate and firm measures, the necessity of a resort to force." He says that he would not unnecessarily cause the shedding of blood. This masterly document, issued in the name and by the authority of the President, was prepared by his secretary of state, Edward Livingston.

On Dec. 17, 1832, the Legislature of South Carolina directed the governor, in view of the President's proclamation, to issue his proclamation to the people of the State, warning them against the "attempt of the President of the United States to seduce them from their allegiance," and exhorting them "to disregard his vain menaces," and calls upon them to protect the liberty of the State. This proclamation was issued Dec. 21, 1832. On Dec. 20, 1832, an act was passed to carry into effect the ordinance, providing judicial remedies for the recovery of goods seized or held for the payment of duties imposed by the act of Congress, and on the same day one was passed regulating the taking of the oath called for by the ordinance.

Virginia responded to the address of the convention of South Carolina, communicating her views through a commissioner sent to that State. Virginia, while holding to the general doctrines propounded and acted upon by South Carolina, did not approve of the adoption of the ordinance, and advised its repeal.

On March 2, 1833, Congress amended the act of 1832, by the Compromise act, the main feature of which was the reduction of the duties imposed by that act where such duties were in excess of 20 per cent. *ad valorem*, to that amount, by a gradual process, that should not be complete until the year 1842. This act was followed on the next day by the Force act, by which the President was authorized to remove any custom-houses, where obstruction existed to the enforcement of the revenue laws, to some convenient place where the collector must remain, and to use the military force to secure the collection of duties at such place. This act also increased the judicial authority of the courts of the United States in revenue cases.

On March 15, 1833, the convention, which had been reconvened, passed an ordinance reciting the act of March 2, 1833, and repealing the ordinance of nullification and secession, and on March 18 adopted an ordinance declaring null the act of Congress known as the Force act, which last measure was followed by an act of the Legislature to carry into effect such annulling ordinance. The repeal of the ordinance of nullification, aimed at the acts imposing duties, left those acts

free to be enforced within that State, and, accordingly, the Force act not being called into operation, the ordinance nullifying it was inoperative, and appears to have received no attention from the national government.

See *Statutes at Large of South Carolina*, vol. i., Appendix; Elliot's *Debates on Federal Constitution*, vol. iv.; Dr. C. J. Stillé on "J. R. Poinsett" in *Penna. Magazine of History* (1888), and STATES RIGHTS. (A. J. W.)

NUMISMATICS, AMERICAN. Only the coins of the United States and its pre-existing colonies will be noticed here. The early settlers of New England found the Indians using *wampum*, or strings of beads made from shells, as a currency, and for other purposes. The General Court of Massachusetts soon recognized this money and fixed an arbitrary rate of exchange. At first six white beads, made from the sea-conch, or three purple, made from the muscle-shell, were taken as equivalent to an English penny. In a few years four white and two purple were declared to have that value. Musket balls and other articles were made legal tender for small amounts and furs and peltry for large sums. The coins brought from England or received in trade from the Dutch and the West Indies tended to flow back to Europe, and what remained in the country were insufficient for the needs of the colonists. On May 27, 1652, therefore, the General Court of Massachusetts ordered a mint to be established in Boston, and John Hull, mint-master, struck silver shillings, sixpences, and threepences. They bore the device of the pine-tree, and were of the same fineness but less in weight than the English coin of the same denomination. For thirty-six years this mint continued in operation in spite of opposition from the mother country. An attempt was made to conciliate King Charles II. by substituting the Royal Oak for the Pine-tree. Other changes were made in the device, but no alteration in the date, which remained always 1652, but two-penny pieces were coined with the date 1662. No other colony had a mint, but in 1659 Lord Baltimore caused shillings, sixpences, and groats to be coined for use in Maryland. James II. issued tin coins for circulation in America, though few seem to have found their way thither. In 1722, 1723, and 1733 copper coins were minted in England with the legend "Rosa Americana." There were also copper half-pence issued in 1773 for circulation in Virginia, and in 1774 silver shillings. Florida and Louisiana had also some colonial coins before they became part of the United States.

When the independence of the American colonies was declared the feeling of the people was manifested in the issue of coins or tokens with patriotic inscriptions. The coins sometimes were authorized by the States, sometimes emitted by traders, or even prepared in England and Germany and sent here as a speculation. Massachusetts in 1787 ventured again to establish a mint, which issued only cents. The other colonies which had a coinage were Connecticut, Vermont, New York, New Jersey, Maryland, and Kentucky. The Continental Congress on Oct. 16, 1786, passed an act for the establishing of a mint, and regulating the value and alloy of the national coin. In July, 1787, the government prescribed the device for copper coin, and under this authority the so-called "Franklin Penny" with the legend "Mind Your Business" was made by contract. The Federal Constitution, ratified in 1789, deprived the States of their former right of coining money. After the Federal government was organized under this Constitution the Mint was established at Philadelphia in 1792 (see MINT) and the regular coinage began in the next year. Copper cents and half-cents, bearing an ideal head, with loose-flowing hair, were first issued. "Washington cents," however, had been prepared as

pattern-pieces in 1791, but, being disapproved by Washington himself, did not become current. In the article on MINT are given the dates of the authorization of the various coins with their respective weights and fineness. The devices have been changed at various times.

Down till about 1837 the obverse had generally a female head, sometimes with a liberty-cap, and sometimes with a fillet bearing the word "Liberty." Afterwards was substituted a full-length seated figure with a liberty-cap on a pole and a shield with a band inscribed "Liberty." The reverse of the principal coins has the eagle, often with a shield, arrows, and olive branch, but in the minor coins the denomination of the piece encircled by a wreath. The coins issued at the branch mints at Charlotte (1830-61), Dahlonega (1838-61), New Orleans (1826-61), San Francisco (1854), and Carson City (1870) are distinguished by the initials C., D., O., S., and C. C., on the reverse.

At the establishment of the mint eagles, or ten-dollar pieces, were the highest denomination authorized. Their coinage was discontinued in 1804 and resumed in 1838 after the gold mines of the Carolinas and Georgia began to furnish a larger supply of the precious metal. The discovery of gold in still greater abundance in California caused demand for a larger coin, and the double-eagle was issued in 1850. Ingots and bars of various sizes were issued by the assayer of the State of California, and after a time a fifty-dollar piece was issued by the U. S. Assay Office in San Francisco. The same excess of gold, which required these larger denominations, called into existence also gold dollars, which were authorized in 1849. Besides the governmental issues there were octagonal and ring dollars and gold half-dollars and quarters put in circulation in California. The Mormons in Utah also had a series of gold coins with peculiar devices, and their favorite inscription, "Holiness to the Lord." The Constitution of the United States prohibited coining by the States, and it has been held that individuals may issue coins which are not similar to the national coinage. Such coins had been issued by Reed in Georgia in 1830, and by the Bechtlers in North Carolina from 1831 for several years.

As works of art the coins of the United States are little esteemed. The finest was the three-dollar piece of 1854, which was soon withdrawn as too close in value to the quarter-eagle. The rarest gold coins of the United States are: Eagles, 1798, 1838; Half-eagles, 1797, 1815, 1822, 1824, 1828; Quarter-eagles, 1796, 1797, 1798, 1806. The Double-eagle of 1849 in the U. S. Mint is the only one in existence. The rarest silver coin is the Half-dime of 1802. Of several coins of rather early date none are known to collectors although their coinage is reported by the Mint. In 1815 no cents were coined, this being the only year in which that coin was not issued. See M. W. Dickeson's *American Numismatological Manual* (Phila., 1859); and Henry Phillips, Jr.'s, *Coins of the United States* (Phila., 1881). (J. P. L.)

NUTTALL, THOMAS (1786-1859), naturalist, was born in Yorkshire, England, in 1786. By trade a printer, he came to the United States, travelled extensively in the Mississippi Valley, exploring both the Missouri and the Arkansas Rivers, and also visited the Pacific coast. Part of his observations appeared in *A Journal of Travels into the Arkansas Territory* (1821). He also published a *Manual of the Ornithology of the United States and Canada* (1834), and in his *North American Sylva* (1817) translated Michaux's work, which he subsequently enlarged (3 vols., 1842-49). From 1822 to 1834 he was professor of natural history in Harvard College, but having inherited an estate in England, returned to that country and died there, Sept. 10, 1859. See BOTANY.

O.

OAK. The highly valuable genus of trees known as *Quercus*, or the oak, is found over nearly all the northern hemisphere, except the extreme north, embracing both deciduous and evergreen species.

The oaks naturally separate into two divisions: the annual-fruited, in which the acorns mature in the autumn of the first year, and the kernel has commonly a sweet taste; and the biennial-fruited, in which the acorns do not mature till the autumn of the second year, and the kernel is always bitter. To the annual-fruited division belongs the group of white oaks, including *Quercus alba*, or the white oak, a large tree with whitish bark and edible seed; *Q. obtusiloba*, the post oak; *Q. macrocarpa*, the burr or over-cup oak; and *Q. lyrata*, the southern over-cup oak. To the same division belong the chestnut oaks, including *Q. bicolor*, the swamp white oak; *Q. prinus*, the chestnut oak; *Q. prinoides*, the dwarf chestnut or chinquapin



Live Oak Grove, Bonaventure, Savannah, Ga.

oak; and the live oak, *Q. virens*, a tree of the barrens from Virginia south, whose wood is very firm and durable, and of the greatest value commercially.

The biennial-fruited oaks include, *Q. cinerea*, the upland willow oak; *Q. Phellos*, the willow oak; *Q. imbricata*, the laurel or shingle oak; *Q. aquatica*, the water oak; *Q. nigra*, the black-jack or barren oak; *Q. ilicifolia*, the black scrub oak; *Q. fulcata*, the Spanish oak; *Q. Catesbary*, the barren scrub oak; *Q. coccinea*, the scarlet oak, with variety *Q. tinctoria*, the black oak; *Q. rubra*, the red oak; and *Q. palustris*, the swamp or pin oak.

In the Pacific States there are several species of the white oak group, including *Q. Garryana*, whose wood is equal to that of the white oak for ship-building; *Q. lobata*; and *Q. Douglasii*. The chestnut oak of California, *Q. densiflora*, is an evergreen; as also is *Q. chrysolepis* and *Q. agrifolia*. The last two of these species are shrubs or trees of 30 to 40 feet high, according as they grow on the mountains or the foot-hills. There are other species of North American oaks, most of them of no economical importance, though *Q. Michauxii*, the basket or cow oak, yields timber that is excellent for wheel stocks, baskets, etc., while its large sweet acorns are eagerly eaten by cattle and other animals.

The white oak gives hard and durable timber, and its bark is used for tanning. The live oak yields a yellow, close-grained timber, which is of unequalled excellence as ship timber, and is highly prized everywhere. Its low habit of branching also enables it to furnish an abundance of excellent ship-knees. The black oak (*Q. tinctoria*) yields a timber second only to that of the white oak in value, while its bark contains much tannin and an abundance of coloring matter, and is much used in tanning and dyeing. Other oaks of commercial utility might be cited, but the above named are the most valuable.

(C. M.)

OAKLAND, a beautiful city of California, the county-seat of Alameda co., is on the E. shore of San Francisco Bay, 4½ miles from San Francisco. It is the terminus of the Central Pacific and Southern Pacific Railroads. Two narrow-gauge railroads, the South Pacific Coast and the California and Nevada, also terminate here, and there are two local steam railroads and ferries to San Francisco. Across Oakland estuary there are two railroad draw-bridges and one for general use. The city contains a court-house, hall of records, city-hall, one national and 2 other banks, 3 daily and 6 weekly newspapers, 30 churches, 25 schools, and the State Home for the Adult Blind. It has several foundries, canning-factories, and cotton-, jute-, woollen-, iron-, and nail-mills, and manufactures of shoes, leather, pottery, carriages, agricultural implements, etc. The city is on a plateau shut in by hills and the bay, the wide streets are macadamized and trees and flowers are seen on all sides. The property of the city is valued at \$30,000,000. It has gas- and water-works and other public conveniences. It was settled in 1850 and incorporated in 1852, but only fairly began to grow in 1868, when the Central Pacific Railroad established the ferry and local railroad. No charge is made on these roads for riding within the city limits. In the centre of the city is a salt water reservoir used for flushing the sewers. In 1880 the population was 34,554.

OATS. See under AGRICULTURE, chap. v. 1.

OBSERVATORIES IN THE UNITED STATES.

The honor of founding the first astronomical observatory in America has been claimed for the University of North Carolina. In 1824 Dr. Joseph Caldwell, the president of that university, purchased in London a meridian transit instrument and a zenith telescope by Simms, a refractor by Dollond, an astronomical clock by Molyneux, a sextant by Wilkinson, a reflecting circle by Harris, and a Hadley's quadrant, and these instruments were used in the university-building till 1831, when they were placed in an "observatory" especially designed for their reception.

Observations were made at this place by Dr. Caldwell, Prof. Elisha Mitchell, and Prof. James Phillips, but the records have been lost. The instruments were removed in 1835, and in 1838 the building was partially destroyed by fire, and astronomical activity was never renewed. The Hopkins Observatory of Williams College, erected in 1836, is the oldest observatory that has continued its activity to the present time, while the observatory of the Western Reserve College, Hudson, Ohio (1838), and the High School Observatory at Philadelphia (1838-1840), which became famous under Walker and Kendall, deserve especial mention in the early history of practical astronomy in this country. These were followed by the Cincinnati Observatory, in 1842, the United States Naval Observatory at Washington, in 1844, and the Harvard Observatory at Cambridge, erected about the same time. In later years we have the Washburn Observatory (1880), the McCormick Observatory (1884), and finally the Lick Observatory, with its magnificent equipment, finished in 1888.

The following list contains a brief description of the most important observatories in the United States. The longitude, when obtainable, is referred to the meridian of Greenwich.

Akron, Ohio, Buchtel College Observatory, lat. + 41° 3', long. 5^h 26^m W. Built in 1885-86; 4½-in. equatorial by Pike & Sons; 3-in. transit circle, with zenith telescope attachment, by Fauth; sidereal and mean time clocks, chronograph, and apparatus for dropping a time-ball and correcting a system of controlled clocks. The observatory is intended for the instruction of students and the maintenance of a time-service. Cost, about \$5000. Director, C. S. Howe.

Albany, N. Y., Dudley Observatory, lat. + 42° 39' 49".5, long. 4^h 54^m 59".2 W. Founded by subscription in 1851; inaugurated 1856; became a department of Union University in 1873. The instruments are: a 13-in. Fitz equatorial, 8-in. Pistor & Martins meridian circle, 6.4-in. transit instrument by the same makers, 4-in. comet-seeker, clocks, chronographs, and subsidiary apparatus. With the meridian circle the *Astronomische Gesellschaft* zone, from + 1° to + 5° declination, has been observed by Prof. Boss. Time-signals are supplied to the city of Albany. Directors: B. A. Gould, 1854; O. M. Mitchel, 1859; G. W. Hough, 1862; Lewis Boss, 1875.

Allegheny, Pa., Observatory of the Western University of Pennsylvania, lat. + 40° 27' 41".6, long. 5^h 20^m 2".9. 13-in. Fitz equatorial, reworked by Clark, 4-in. Troughton & Simms transit, spectroscopes, photometers, bolometer. Prof. S. P. Langley, the director, has made important investigations in solar physics at this observatory, and has also, since 1869, maintained a very efficient time-service over the Pennsylvania Railroad system.

Amherst, Mass., Lawrence Observatory of Amherst College, lat. + 42° 22' 15".6, long. 4^h 50^m 7".3 W. Erected in 1847; 7½-in. equatorial by Clark; 6½-in. transit instrument by Pistor & Martins, rebuilt by Fauth; 3-in. transit circle by Gambey; clocks, chronograph, and smaller instruments. The observatory is chiefly for instruction. Director, D. P. Todd.

Annapolis, Md., lat. + 38° 58' 53".5, long. 5^h 5^m 56".5 W. U. S. Naval Academy Observatory, used for instruction only; 7½-in. equatorial, made by Clark in 1857, 4-in. Repsold meridian circle, small transit and zenith telescope, both by Würdemann, a combined transit and zenith telescope of the Russian pattern by Stackpole, clock, chronometers, chronographs, etc. The department of astronomy was created in 1853, and until 1859 was under the charge of Prof. William Chauvenet.

Ann Arbor, Mich., lat. + 42° 16' 48".0, long. 5^h 34^m 55".2 W. Erected in 1853-54 by the citizens of Detroit, and hence known as the Detroit Observatory; it forms a department of the University of Michigan. The instruments are: a 13-in. Fitz equatorial, a 6½-in. Pistor & Martins transit circle, clocks, and chronograph. A students' observatory contains a 6-in. equatorial and 3-in. transit, with zenith telescope attachment. The observatory-plant is valued at about \$40,000. Directors: F. Briinnow, 1854; J. C. Watson, 1858; M. W. Harrington, 1879. Watson discovered 21 asteroids here.

Baltimore, Md., Denmore Observatory, private observatory of Mr. W. H. Nunsen, lat. + 39° 21', long. 5^h 6^m 52" W.; 4-in. Cooke equatorial.

Beloit, Wis., Smith Observatory. 9.5-in. equatorial, objective by Clark, mounting by Warner & Swasey. Directors: John Tatlock, Jr., 1884; C. A. Bacon, 1886.

Berkeley, Cal., students' observatory of the University of California. 6-in. Fauth equatorial, with spectroscope and other attachments. 3-in. combined transit and zenith telescope of the "Davidson pattern" made by Fauth, clock, chronometer, chronograph, and other accessories for instruction of engineering students, or

original work by students of astronomy. Director, Frank Soulé.

Bethlehem, Pa., Sayre Observatory of Lehigh University, lat. + 40° 36' 23".9, long. 5^h 1^m 31".9 W. Founded in 1877; 6-in. Clark equatorial, Stackpole transit and zenith telescope. Director, C. L. Doolittle.

Boston, Mass., private observatory of Mr. C. L. Woodside (1886); lat. + 42° 22' 39", long. 4^h 44^m 9" W.; 6½-inch silvered glass reflector.

Brooklyn, N. Y., private observatory of H. M. Parkhurst; lat. + 40° 41' 2", long. 4^h 55^m 50" W. Built in 1862; rebuilt in 1877; a 9-in. Fitz equatorial has been used principally in photometric observations.

Cambridge, Mass., Observatory of Harvard College; lat. + 42° 22' 48".3, long. 4^h 44^m 31".0 W. Founded in 1843. As early as 1815 an observatory was projected, and in 1827 the Dana house was purchased to serve at least as a temporary astronomical establishment. In 1839 Mr. W. C. Bond was appointed "astronomical observer for the college" and carried on a series of observations in co-operation with the Wilkes expedition till 1842. The provisional observatory at the Dana house contained a Troughton & Simms transit of 2¼-in. aperture, a Short telescope of 5-ft. focus, and magnetical and meteorological instruments. In 1841 the present site of the observatory, then known as Summer House Hill, was purchased. In 1843, under the enthusiasm aroused by the sudden appearance of the great comet of that year, the sum of \$25,730 was subscribed for the purpose of erecting an observatory and providing it with a telescope of the largest size. The buildings were finished in 1844. The 15-in. refractor (costing \$19,842), by Merz & Mahler, of Munich, was mounted in 1847. With this instrument G. P. Bond discovered the seventh satellite of Saturn, Hyperion, in 1848, and the inner or dusky ring of Saturn in 1850. The observatory possessed also two 4-in. comet-seekers, and a 4½-in. equatorial, which was replaced, however, in 1869, by one of 5½ in. made by Clark. A chronograph or spring-governor, the invention of W. C. Bond, was first brought into use here in 1849. A Troughton & Simms meridian circle of 8½-in. aperture, embodying several new features suggested by Prof. Winlock, and a 2¼-in. "Russian" transit were mounted in 1870. With the former instrument the *Astronomische Gesellschaft* zone, + 50° to + 55°, was observed by Prof. W. A. Rogers. A horizontal photoheliograph of 40 ft. focus, devised by Prof. Winlock, was successfully used in photographing the sun in 1870. Prof. Pickering added several photometers of his own invention to the equipment, the most important being a large meridian photometer constructed in 1883. Since 1885 much attention has been given to astronomical photography. Mrs. Henry Draper has lent to the observatory the principal instruments of Dr. Draper's observatory at Hastings, an 11-in. Clark equatorial and 15-in. and 28-in. reflectors, and has furnished means for carrying on a special investigation of stellar spectra by means of photography. With these instruments extremely valuable results have already been obtained. In 1887 a fund amounting to \$238,000, left by Uriah A. Boyden for conducting astronomical observations at such a height as to be free so far as possible from the injurious effects due to the atmosphere, was transferred to Harvard College. Experiments, mainly in the line of stellar photography, are being conducted by Prof. Pickering in carrying out the provisions of this trust. A high altitude station in the southern hemisphere will be occupied and a series of observations carried on in co-operation with a similar station in the United States. A 13-in. equatorial, designed by Prof. Pickering, adapted to either visual or photographic purposes, has been built by the Clarks, and a second telescope of 8-in. aperture is mounted on the same stand. A complete photographic

laboratory is fitted up in an adjoining building. The funds of the observatory, which in 1875 amounted to \$164,067, and in 1885 to \$226,988, were increased by a bequest from R. T. Paine, in 1886, to \$398,046, placing the observatory on a very satisfactory financial footing. An extensive time-service, established in 1871, also contributes to the support of the institution. Seventeen quarto volumes of *Annals* have been published, and a report of the director appears each year as an appendix to the report of the president of the college. The Harvard Observatory is the central station in the United States for the telegraphic distribution of astronomical information. Directors: W. C. Bond, 1839; G. P. Bond, 1859; Joseph Winlock, 1866; E. C. Pickering, 1877.

Cambridgeport, Mass., Mr. E. F. Sawyer's private observatory: lat. $+42^{\circ} 21' 56''$, long. $4^{\circ} 44' 23''$ W.; $3\frac{1}{2}$ Bordan equatorial used for observations of variable stars and meteors; several interesting variables of short period have recently been discovered.

Chicago, Ill., Dearborn Observatory, lat. $+41^{\circ} 50' 1''$, long. $5^{\circ} 50' 26''.8$ W. Founded by the Chicago Astronomical Society in 1862-63, and attached to the University of Chicago. Principal instruments, 18 $\frac{1}{2}$ -in. Clark equatorial, and 6-in. Repsold meridian circle. The equatorial has been mainly devoted to double-star work by Burnham and Hough. With the meridian circle, work was begun upon the *Astronomische Gesellschaft* zone, $+35^{\circ}$ to $+40^{\circ}$, but was not completed. Since 1871 this instrument has been used for determining time for the city of Chicago. Directors: T. H. Safford, 1865; E. Colbert, 1874; G. W. Hough, 1879.

In 1888 the observatory was transferred to the North-western University, and the instruments were mounted in a new building at Evanston, Ill., 16 miles N. and 3 miles W. of the old site.

Cincinnati, Ohio, lat. $+39^{\circ} 8' 19''.5$, long. $5^{\circ} 37' 41''.2$ W. The Cincinnati Observatory was founded in 1841-43 by the Cincinnati Astronomical Society, and owes its existence to the energy and eloquence of Prof. O. M. Mitchel. A new building was erected in 1873 upon Mount Lookout, about 4 miles E. and 2 miles S. of the central part of the city, the observatory having become in 1872 a department of the University of Cincinnati. The instruments are: an 11 $\frac{1}{2}$ -in. equatorial made by Utschneider & Fraunhofer, finished by Merz & Mahler, and objective refigured by Clark; 4-in. equatorial, by Clark; 3-in. transit, by Buff & Berger; clocks, chronometer, chronograph, etc.; a 5 $\frac{1}{2}$ -in. meridian circle, by Fauth, was added to the equipment in 1888. Directors: O. M. Mitchel, 1842; H. Twitchel, 1859; W. Davis, 1861; C. Abbe, 1868; O. Stone, 1875; J. G. Porter, 1884. Observations of double stars and comets made with the equatorial and a zone-catalogue observed with the transit have filled nine numbers of *Publications*.

Clinton, N. Y., Litchfield Observatory of Hamilton College, lat. $+43^{\circ} 3' 17''.0$, long. $5^{\circ} 1' 37''.4$ W. Founded by subscription, 1852-55; 13 $\frac{1}{2}$ -in. equatorial by Spencer & Eaton, 4-in. equatorial by Steinheil, 5-in. altazimuth by Schröder, clock, chronometer, chronograph, and spectroscope. With the 13 $\frac{1}{2}$ -in. equatorial Dr. C. H. F. Peters, the director, has constructed a series of ecliptic charts, and in the course of this work he has discovered 47 asteroids.

Columbia, Mo., Laws Observatory of the University of the State of Missouri, lat. $+38^{\circ} 56'$, long. $6^{\circ} 9' 18''$ W.; 7 $\frac{1}{2}$ -in. Merz equatorial, 4 $\frac{1}{2}$ -in. Fitz equatorial, 2 $\frac{1}{2}$ -in. Brunner meridian circle, altazimuth clocks and minor apparatus; used mainly for instruction.

Crete, Nebraska. Boswell Observatory of Doane College (1883): 8-in. Clark equatorial, Buff & Berger transit, clocks, break circuit chronometer, and meteorological apparatus. Building and instruments cost \$7000.

Denver, Col. A new observatory, the gift of Mr. H. B. Chamberlin to the University of Denver, is in course of construction about 6 miles from the centre

of the city, at a height of 5000 feet above sea-level. The principal instrument will be a 20-in. Clark equatorial. Director, H. A. Howe.

Evanston, Ill., Dearborn Observatory, transferred from Chicago in 1888.

Geneva, N. Y., Smith Observatory, lat. $+42^{\circ} 53'$, long. $5^{\circ} 8''$ W. Built by William Smith in 1888; equatorial of 10 $\frac{1}{2}$ in. aperture, 9 ft. 9 in. focal length, object-glass by Clacey, mounting by Warner & Swasey, provided with a photographic corrector of the same aperture, spectroscope, micrometer, etc.; a 4-in. meridian circle by Warner & Swasey; a sidereal clock wound automatically by a small electro-motor, and a chronograph. Also a 9-in. silver on glass reflector, a 5-in. reflector, and several smaller instruments constructed by the director, Mr. W. R. Brooks, and formerly used at the Red House Observatory, Phelps, N. Y., in the discovery of 13 comets.

Georgetown (D. C.) College Observatory, lat. $+38^{\circ} 54' 26''.2$, long. $5^{\circ} 8' 18''.3$ W. Erected in 1843-44; 4.8-in. Simms equatorial, 4-in. Troughton & Simms meridian circle, and 4.6 in. Ertel transit. The equatorial was used by Sestini in 1850 for a series of observations of sun spots. A single volume of *Annals*, giving a description of the building and instruments, was published, in 1852, by James Curley.

Glasgow, Mo., Morrison Observatory, lat. $+39^{\circ} 13' 45''.6$, long. $6^{\circ} 11' 18''$ W. Founded in 1874 by Miss Berenice Morrison; 12 $\frac{1}{2}$ -in. Clark equatorial, 6-in. Troughton & Simms meridian circle, clocks, chronometer, and chronograph. Volume I. of the *Publications* issued in 1887 contains a description of the observatory, and observations of planets, comets, and double stars. Time signals have been sent to Kansas City and St. Louis, and over the line of the Chicago and Alton Railroad. Director, C. W. Pritchett.

Greencastle, Ind., McKim Observatory, lat. $+39^{\circ} 37'$, long. $5^{\circ} 46' 30''$ W. The gift of Mr. Robert McKim to De Pauw University, 1885; entire cost \$10,000. The principal instrument is a 9 $\frac{1}{2}$ -in. equatorial; an almicantar is used for time observations.

Griinnell, Iowa. Mr. Griinnell has provided Iowa College with an astronomical observatory mounting an 8-in. Clark equatorial (1887).

Hanover, N. H., Shattuck Observatory of Dartmouth College, lat. $+43^{\circ} 42' 15''$, long. $4^{\circ} 49' 8''$ W. Founded in 1853; 9 $\frac{1}{2}$ -in. Clark equatorial, 4-in. Troughton & Simms meridian circle, clocks, chronograph, and spectroscopes. Directors: C. A. Young, 1853; C. F. Emerson, 1878.

Hastings, N. Y., Prof. Henry Draper's Observatory, lat. $+40^{\circ} 59' 25''$, long. $4^{\circ} 55' 29''.7$ W. Built in 1860; 28-in. reflector made by Prof. Draper, 11-in. refractor with photographic corrector by Clark, used until Prof. Draper's death in 1882 for experiments in astronomical photography; in 1886-87 they were removed to the Harvard College Observatory.

Haverford (Pa.) College Observatory, lat. $+40^{\circ} 0' 40''.1$, long. $+5^{\circ} 1' 12''.7$; 8 $\frac{1}{2}$ -in. Fitz equatorial, refigured by Clark, 4-in. meridian circle, 1 $\frac{1}{2}$ -in. zenith telescope, 8 $\frac{1}{2}$ -in. Brashear reflector, clocks and chronograph. The observatory was rebuilt in 1883 and provided with a 10-in. Clark refractor. Directors: Jos. G. Harlan, 1853; S. J. Gummere, —; Samuel Alsup, Jr., 1875; Isaac Sharpless, 1882; F. P. Leavenworth, 1887.

Hillsborough, Ohio, private observatory of Henry A. Pavey; 4-in. equatorial by Benj. Pikes' Sons.

Iowa City, Iowa, private observatory of C. W. Irish, lat. $+41^{\circ} 39'.8$, long. $6^{\circ} 6' 4''$ W.; 4-in. equatorial by Chevalier.

Lancaster, Pa., Daniel Scholl Observatory. Erected in 1887; attached to Franklin and Marshall College; 11-in. equatorial, objective by Clark, mounting by Repsold, 3-in. transit, clock chronometer and chronograph.

Lewisburg, Pa., Bucknell University Observatory. Founded in 1887 by Mr. William Bucknell. The build-

ing is of brick, 25 ft. by 50 ft., a dome 16 ft. in diameter surmounting the central tower; the instruments are a 10-in. Clark equatorial and a 3-in. Ertel transit, chiefly for instruction. The entire cost was \$10,000. Director, W. C. Bartol.

McCormick Observatory. See *University of Virginia*.

Madison, Wis., Washburn Observatory, lat. $+ 43^{\circ} 4' 36''$.7, long. $5^{\text{h}} 57^{\text{m}} 37^{\text{s}}$.9 W. Built in 1878-80 by Gov. C. C. Washburn at a cost of about \$50,000, and presented to the University of Wisconsin. The instruments are a 15½-in. Clark equatorial, 4.8-in. Repsold meridian circle, chronograph, clocks, chronometers, etc. A 6-in. Clark equatorial, formerly the property of S. W. Burnham, and a 3-in. Fauth transit are mounted in a students' observatory adjoining the main building. The equatorial has been used for observations of double stars, comets, and nebulae; the meridian circle for observations of Anwers' 303 southern stars. Directors: J. C. Watson, 1879; E. S. Holden, 1881; J. E. Davies, 1886; G. C. Comstock, director, Asaph Hall, consulting director, 1887. Five volumes of *Publications* have been issued.

Mount Hamilton, Cal., Lick Observatory of the University of California, lat. $+ 37^{\circ} 20' 23''$.5, long. $8^{\text{h}} 6^{\text{m}} 34^{\text{s}}$.1 W., height above sea-level, 4302. Founded by James Lick through a deed of trust dated Sept. 21, 1875, in which he devoted \$700,000 to the construction of a telescope "superior to and more powerful than any telescope ever yet made . . . and also a suitable observatory connected therewith." The work of construction was begun by the Lick trustees in 1880, and the observatory was completed and delivered, in accordance with the terms of Mr. Lick's will, to the Regents of the University of California, June 1, 1888. In the main building are computing-rooms, a library, and the domes for the 36-in. and 12-in. equatorials, and detached buildings contain a 6½-in. Repsold meridian circle, 6½-in. Warner & Swasey equatorial, 4-in. Fauth combined transit and zenith telescope, and 5-in. horizontal photoheliograph, the objectives for all these instruments being furnished by Alvan Clark & Sons. A 4-in. Clark comet-seeker, 2.1-in. Repsold universal instrument, 5 clocks, 5 chronometers, 3 chronographs, measuring engine, and minor apparatus complete the equipment. The visual objective of the great equatorial has a clear aperture of 36 in. and focal length of 56 ft., 6 in.; the flint disc for this objective was obtained by Clark from Feil & Co., of Paris, in 1882, and after nineteen failures the crown was cast by the same makers in 1885. The objective was completed and delivered by the Clarks in 1886. It cost \$51,000 and weighs, with its cell, about one-third of a ton. In 1887 a third (crown) lens of 33 in. aperture and 46 ft. focal length was procured, at a cost of about \$14,000, as a "photographic corrector." The equatorial mounting was made by Warner & Swasey and put in place in 1887 for \$42,000. The total weight of the telescope is about 40 tons. The dome is of steel, 75 ft. in diameter, and has a floor movable vertically 16½ ft. The cost of the dome and floor was \$56,800. Volume I. of the *Publications*, issued in 1887, contains a description of the buildings and instruments, a list of double stars discovered and measured by Mr. Burnham upon the site of the observatory in 1879 and 1881, observations of the transit of Mercury in 1881 and of the transit of Venus in 1882, and an extensive series of reduction tables. A time-service is in operation over the whole Pacific system of railways from Ogden to El Paso. The observatory has an endowment fund of somewhat over \$100,000 remaining from the original bequest of \$700,000, and the further expenses are provided for by the Regents of the University. Director, E. S. Holden.

Nashville, Tenn., Vanderbilt University Observatory, lat. $+ 36^{\circ} 8' 58''$.2, long. $5^{\text{h}} 47^{\text{m}} 12^{\text{s}}$.8 W., 6-in. Cook equatorial, 4-in. Ertel meridian circle, 3-in. Cooke altazimuth, clocks, and chronograph. A 5-in. portable

refractor was used by Mr. E. E. Barnard in the discovery of a number of comets.

New Haven, Conn., Observatory of Yale University, lat. $+ 41^{\circ} 18' 36''$.5, long. $4^{\text{h}} 51^{\text{m}} 42^{\text{s}}$.2 W. In 1830 a 5-in. refractor was purchased from Dollond and mounted in the steeple of one of the college buildings; subsequently a 3.8-in. meridian circle by Ertel, formerly the property of the U. S. Naval Observatory, a meridian transit with object glass by Fitz, mounting by Prof. C. S. Lyman, a 9-in. Clark equatorial, a 4-in. transit by Troughton and Simms, and minor instruments were added to the equipment. In 1882 a new observatory was built and supplied with a 6-in. Repsold heliometer (cost \$7500) and an 8-in. Grubb equatorial. A time-service and bureau for testing thermometers were established in 1880. Volume I., part 1, of *Transactions*, published in 1887, contains Dr. Elkin's heliometer measures of the brighter stars in the group of the Pleiades. Directors: E. Loomis, 1831; D. Olmsted, 1836; C. S. Lyman, 1847; H. C. Newton, 1882. Since 1884 the observatory has been in charge of a board of directors.

Newington, Conn., private observatory of D. W. Edgecomb; lat. $+ 41^{\circ} 44' 0''$, long. $4^{\text{h}} 46^{\text{m}} 47^{\text{s}}$ W.; 9.4-in. Clark equatorial.

New Windsor, Ill., private observatory of E. L. Larkin; lat. $+ 41^{\circ} 13'$, long. $6^{\text{h}} 1^{\text{m}} 52^{\text{s}}$ W.; 6-in. Clark equatorial.

New York, N. Y., Columbia College Observatory, lat. $+ 40^{\circ} 45' 23''$.1, long. $4^{\text{h}} 55^{\text{m}} 53^{\text{s}}$.7 W. The observatory is upon the top of the library building of Columbia College, the floor being 100 ft. above the level of the street. Instruments: 5-in. equatorial, combined transit and zenith telescope, clocks, chronometers, spectroscopes, etc. To these were added in 1884 the instruments of Mr. L. M. Rutherford's observatory, a 13-in. equatorial with photographic corrector, 3-in. Stackpole transit, and other apparatus. Director, J. K. Rees.

New York, N. Y., private observatory of L. M. Rutherford, lat. $+ 40^{\circ} 43' 48''$.5, long. $4^{\text{h}} 55^{\text{m}} 56^{\text{s}}$.6 W.; 13-in. equatorial by Rutherford & Fitz, used for celestial photography, 3-in. Stackpole transit. The instruments were dismantled in 1884 and presented to Columbia College.

Northampton, Mass., Smith College Observatory, lat. $+ 42^{\circ} 19' 7''$, long. $4^{\text{h}} 50^{\text{m}} 32^{\text{s}}$.9 W. Erected in 1886; a one-story brick building containing an equatorial room, photographic dark-room, library, clock-room, and transit-room. The equatorial is of 11 in. aperture, objective by Clark, mounting by Warner & Swasey, meridian circle of 4-in. aperture by Warner & Swasey, and chronograph by the same makers. A spectroscope for solar and stellar work is fitted to the equatorial. Director, Miss Mary E. Byrd, 1887.

Northfield, Minn., Carleton College Observatory, lat. $+ 44^{\circ} 27' 40''$.8, long. $6^{\text{h}} 12^{\text{m}} 35^{\text{s}}$.9 W. Erected in 1878; 8½-in. Clark equatorial, 3-in. Fauth transit, clocks, chronometer, chronograph, and minor instruments. The observatory was rebuilt in 1886-88, and the 8½-in. refractor provided with a photographic corrector. A Repsold meridian circle with object glass 4.8 in. aperture, by Clark, was mounted in 1887. Time signals are sent out over several railroads. Director, W. W. Payne.

Oakland, Cal., Chabot Observatory, lat. $+ 37^{\circ} 48' 5''$, long. $8^{\text{h}} 9^{\text{m}} 6^{\text{s}}$.4 W. Presented to the city of Oakland in 1886 by Mr. Anthony Chabot. Instruments: an 8½-in. equatorial with micrometer and spectroscope, a 4½-in. transit, chronograph, and clocks. Director, F. M. Campbell.

Omaha, Neb., Creighton College Observatory, lat. $+ 41^{\circ} 16' 6''$, long. $6^{\text{h}} 23^{\text{m}} 47^{\text{s}}$ W.; 5-in. equatorial by I. H. Steward, London; 3-in. transit circle by Fauth, clocks, chronograph, etc. A 12-in. equatorial will be added to the equipment.

Phelps, N. Y., Red House Observatory, lat. $+ 42^{\circ} 58'$, long. $5^{\text{h}} 8^{\text{m}} 24^{\text{s}}$ W.; 9-in. and 5-in. silvered glass

reflectors, both by the owner, W. R. Brooks. The instruments were removed in 1888 to the Smith Observatory, Geneva, N. Y. They have served in the discovery of 13 comets.

Poughkeepsie, N. Y., Vassar College Observatory, lat. $+ 41^{\circ} 41' 18''$, long. $4^{\text{h}} 55^{\text{m}} 33.6^{\text{W}}$. Built in 1878; 12 $\frac{1}{2}$ -in. Clark equatorial, 3 $\frac{1}{2}$ -in. meridian circle, clock, chronometer, chronograph. Miss Maria Mitchell was succeeded as director by Miss M. W. Whitney in 1888.

Princeton, N. J., Observatory of Princeton University, consisting of the observatory of the J. C. Green School of Science, lat. $+ 40^{\circ} 20' 57''.8$, long. $4^{\text{h}} 58^{\text{m}} 37.6^{\text{W}}$, and the Halsted Observatory. The J. C. Green Observatory was built in 1877 for instruction in practical astronomy, and contains a 9 $\frac{1}{2}$ -in. Clark equatorial, 4-in. Fauth meridian circle, 3-in. Fauth transit, 2 $\frac{1}{2}$ -in. Kahler transit, Ayerigg transit mounted in the prime vertical, besides clocks, chronometers, and subsidiary apparatus. The Halsted Observatory has a 23-in. Clark equatorial (mounted in 1883), provided with several large spectroscopes. Director, C. A. Young.

Providence, R. I., private observatory of F. D. Seagrave, lat. $+ 41^{\circ} 49' 46''.4$, long. $4^{\text{h}} 45^{\text{m}} 37.6^{\text{W}}$; 8 $\frac{1}{2}$ -in. Clark equatorial, with Browning spectroscope.

Rochester, N. Y., Warner Observatory, lat. $+ 43^{\circ} 8' 15''$, long. $5^{\text{h}} 11^{\text{m}} 20^{\text{W}}$. Erected in 1879-80 by H. H. Warner; 16-in. Clark refractor, used mainly in the search for new nebulae. Director, Lewis Swift.

St. Louis, Mo., Observatory of Washington University, lat. $+ 38^{\circ} 38' 3''.6$, long. $6^{\text{h}} 0^{\text{m}} 49.1^{\text{W}}$; 6 $\frac{1}{2}$ -in. Fitz equatorial, 2.6-in. Würdemann transit, clocks, spectroscope, photometer, etc. An extensive time-service is maintained. Director, H. S. Pritchett.

San José, Cal., Observatory of the University of the Pacific (1885); 6-in. Clark equatorial, Fauth transit. Director, J. C. George.

South Evanston, Ill., Observatory of Dr. Marshall D. Ewell, built in 1886, 10.8 miles south of Chicago. The instruments are a 6 $\frac{1}{2}$ -in. Clark equatorial, mounted on a pier made of Portland cement and sand, a 2 $\frac{1}{2}$ -in. Troughton & Simms transit, a sidereal and a mean time clock, and subsidiary apparatus.

South Hadley, Mass., Observatory of Mount Holyoke Seminary, lat. $+ 42^{\circ} 15' 18''.2$, long. $4^{\text{h}} 50^{\text{m}} 20.3^{\text{W}}$; 8-in. Clark equatorial, 3-in. Fauth meridian circle, clock, and chronograph. The building and its equipment cost about \$10,000.

Syracuse, N. Y., Observatory of the University of Syracuse. Founded in 1887; 8-in. Clark equatorial, 3-in. Troughton & Simms transit, clock, chronometer, and chronograph. Director, J. R. French.

Tarrytown, N. Y., private observatory of C. H. Rockwell, lat. $+ 41^{\circ} 4' 21''$, long. $4^{\text{h}} 55^{\text{m}} 24.9^{\text{W}}$; 6 $\frac{1}{2}$ -in. equatorial, object glass by Dr. C. S. Hastings, mounting by Byrne. An almicantar is used for determining time.

Troy, N. Y., Williams Prondfit Observatory, lat. $+ 42^{\circ} 43' 52''$, long. $4^{\text{h}} 54^{\text{m}} 45^{\text{W}}$. Attached to the Rensselaer Polytechnic Institute; 3.5-in. Fitz equatorial, 2.5-in. Kübel transit, 2-in. Phelps & Gurley transit, clocks, and chronometer. Director, Daseom Greene.

University of Virginia, Va., McCormick Observatory, lat. $+ 38^{\circ} 2' 1.2''$, long. $5^{\text{h}} 14^{\text{m}} 5.2^{\text{W}}$, near Charlottesville. A small astronomical observatory was built by Thomas Jefferson in 1825, but no instruments were mounted, and the building was removed in 1855 or 1856. The present observatory was built in 1883-84 at a cost of about \$70,000, of which \$64,000 was the gift of Leander J. McCormick. A working fund of \$25,000 was given by W. H. Vanderbilt, and an endowment of \$50,000 was subscribed by the alumni of the university. In 1882 Prof. Ormond Stone was chosen director, and the observatory was dedicated Apr. 13, 1885. The principal instrument is a 26-in. Clark equatorial, used for the study of faint nebulae

and the observation of comets and double stars. There is also a 4-in. equatorial by Kahler and a 3-in. transit by Fauth.

Washington, D. C., U. S. Naval Observatory, lat. $+ 38^{\circ} 53' 38''.8$, long. $5^{\text{h}} 8^{\text{m}} 12.09^{\text{W}}$. Founded in 1842 by act of Congress as a depot of charts and instruments for the navy. Numerous efforts, beginning in 1810, had been made to obtain authority and funds for a national observatory, but without success. In 1838 a series of observations was begun by Lieut. J. M. Gilliss in a small observatory upon Capitol Hill, connected with the depot of charts, in co-operation with the Wilkes expedition. These observations were continued until 1842, when the sum of \$25,000 was appropriated for the erection of a more permanent and suitable depot. The building, as planned by Lieut. Gilliss, was completed in 1844. Additions were made in 1847, 1848, 1868, and 1873. The following instruments have been in use: 4.1-in. Troughton & Simms mural circle (mounted in 1844); 5.3-in. Ertel transit (mounted in 1844, object-glass reground by Clark in 1862); 4.9-in. Pistor & Martins prime vertical transit (1845); 9.6-in. Merz & Mahler equatorial (1845); 4-in. Utschneider & Fraunhofer comet-seeker; 3.8-in. Ertel meridian circle; 6.6-in. Ertel refraction circle; 8.5-in. Pistor & Martins transit circle (1866); 26-in. Clark equatorial (1873; cost, \$46,000). There are also 4 chronographs, 6 clocks, chronometers, and subsidiary apparatus, and the photoheliographs, transits, equatorials, and other instruments used by the American parties in observations of the transits of Venus in 1874 and 1882 are stored here. The 26-in. equatorial has been used principally in the measurement of faint double stars and satellites and in observations for stellar parallax. With this instrument Prof. Hall discovered in 1877 the two satellites of Mars. The chronometers for issue to naval vessels are rated and tested in a suitably built room in the observatory, and an extensive time-service is maintained, involving the automatic correction daily of about 250 Gardner clocks in the various government departments in Washington and the dropping of time-balls at New York, Philadelphia, Baltimore, Washington, Hampton Roads, Savannah, and New Orleans. Thirty quarto volumes of observations and memoirs have been published, besides the annual report of the superintendent, which is appended to the report of the Secretary of the Navy. In 1880 a new site for the observatory was purchased about $\frac{1}{2}$ mile north and $\frac{1}{4}$ mile west of the present location, the latter being regarded as unhealthy and the efficiency of the instruments being impaired there by the fogs and the proximity to the Potomac River. Plans for the new buildings were prepared, but Congress failed to make any appropriation for their construction until 1886, when \$100,000 were made available for this purpose with the provision that the total cost should not exceed \$400,000. New plans were prepared, their main feature being the erection of small detached buildings for each of the principal instruments, while the offices and computing-rooms are united in a main building, and work was begun in the autumn of 1888. The observatory as a naval institution comes under the bureau of navigation, and line officers of the navy are detailed at intervals to perform the duties of superintendent. The following officers have held this position: M. F. Maury, 1844; J. M. Gilliss, 1861; C. H. Davis, 1865; B. F. Sands, 1867; C. H. Davis, 1874; John Rodgers, 1877; S. C. Rowan, 1882; R. W. Shufeldt, 1883; S. R. Franklin, 1884; G. E. Belknap, 1885; A. D. Brown, 1886; R. L. Phythian, 1886.

West Point, N. Y., Observatory of the United States Military Academy, lat. $+ 41^{\circ} 23' 31''$, long. $4^{\text{h}} 55^{\text{m}} 49.4^{\text{W}}$. Erected in 1839; 9 $\frac{1}{2}$ -in. Fitz equatorial, 4.6-in. transit by Ertel & Son (mounted in 1843), 4-in. mural circle by Troughton & Simms, and several smaller field-instruments. The instruments are used almost entirely for the instruction of cadets.

A new observatory was built in 1883; lat. $+41^{\circ} 23' 22''$.1, long. $4^{\text{h}} 55^{\text{m}} 50^{\text{s}}$.6 W., 480 ft. above sea-level, containing a 12-in. Clark equatorial, mounted in 1884, and an 8-inch Repsold meridian circle, mounted in 1885.

Willet's Point, N. Y., Observatory of the U. S. Army Engineers' School of Application; intended for instruction of engineer officers in the applications of practical astronomy to geodesy. Originally built in 1868, lat. $+40^{\circ} 47' 17''$.7, long. $4^{\text{h}} 55^{\text{m}} 7^{\text{s}}$.5 W.; rebuilt in 1879, lat. $40^{\circ} 47' 21''$.3, long. $4^{\text{h}} 55^{\text{m}} 7^{\text{s}}$.7 W. Instruments: a $5\frac{1}{2}$ -in. equatorial, objective by Clark, mounting by Fauth; a 3.8-in. equatorial by Tulley; a Längke combined transit and zenith telescope of $2\frac{1}{2}$ inches; a 2.6-in. Stackpole Russian transit, also adapted for use as a zenith telescope; a 2-in. Troughton transit; a 2-in. Stackpole transit; and a 2.6-in. Würdemann zenith telescope; chronograph, chronometers, and sextants. Results of observations for time and latitude, and an extensive series of observations of auroræ are published in *General Orders*.

Williamstown, Mass., Observatory of Williams College, lat. $+42^{\circ} 42' 49''$, long. $4^{\text{h}} 52^{\text{m}} 53^{\text{s}}$.5 W. The old or Hopkins Observatory was built in 1836-37 (dedicated June 12, 1838), and furnished with a $7\frac{1}{2}$ -in. Clark equatorial and $3\frac{1}{4}$ -in. Troughton & Simms transit. The Field Memorial Observatory was built in 1882 and a $4\frac{1}{2}$ -in. Repsold meridian circle was mounted on June 24 of that year. Directors: Albert Hopkins, 1836; T. H. Safford, 1879 (?).

Ipsilanti, Mich., State Normal School Observatory, lat. $+42^{\circ} 13'$, long. $5^{\text{h}} 34^{\text{m}} 22^{\text{s}}$ W.; 4-in. Clark equatorial, $1\frac{1}{2}$ -in. Gurley transit.

References: Loomis, *Recent Progress of Astronomy* (N. Y., 1850); André & Angot, *L'Astronomie pratique et les observatoires en Europe et en Amérique, troisième partie* (Paris, 1877); Holden, "Reports of Astronomical Observatories, 1879, 1880" (*Smithsonian Reports*, 1879, 1880); "Progress in Astronomy" [1879-1884] (*Smithsonian Reports*, 1880-1884); Winlock, "Progress in Astronomy" [1885-1888] (*Smithsonian Reports*, 1885-1888); Lancaster, *Liste générale des observatoires et des astronomes* (Bruxelles, 1887).

OBSTETRICS is that branch of medical science which treats of midwifery, child-bearing, parturition, pregnancy. Midwifery has always been regarded as having only to do with the needs of the woman in her hours of delivery; hence, according to ancient laws, the midwife was expected to care for the woman at this time only, and when occasion demanded aid prior to or after the accomplishment of the birth of the child she was required to call in a physician or surgeon as the case might be. Custom subsequently more or less joined to medical treatment of parturition the care of the diseases of women, and also of children, but since the study of gynæcology has so wonderfully progressed, the advanced schools of medicine have separated these subjects, and very judiciously, in many instances, they are entrusted to separate departments for study.

The word *obstetrics* is derived from the Latin *obstare*, to stand before; literally the obstetrician is one who stands before the woman to render her aid in her delivery of a child. The art of delivery has long claimed the attention of all classes, nor is this to be wondered at when we consider that child-bearing is connected with the foundation of the welfare of all races, and that during a fixed time the pregnant woman is an object of the greatest solicitude. At first, as was natural, women alone were regarded as best fitted to be able to render the needed service, and hence midwifery or obstetrics was relegated to the care of women, and so remained for ages. Indeed, at the present time, in many lands, women only are permitted to be present on such occasions, and, in fact, some tribes regard these matters as unfit for the notice of any save the lowest members of their community, and even regard the condition and presence of the pregnant woman as unlucky and likely to cause evil results.

The earliest allusion to the obstetric art is in ancient Jewish history. At first, it appears, there was reluctance to interfere during labor, and only such aid was given as became absolutely necessary in the separation of the child, leaving everything else to the efforts of nature. But as time elapsed, people in attendance on such occasions involuntarily used their common sense in aid of the efforts of the woman, and thus, from observation and experience, some became more skilled and regarded as specially able to aid in the delivery. Again, from seeing what nature unaided could do in difficult labors, they were encouraged to imitate these efforts or aid them, and finding such aid to be followed by good results, a similar plan was employed in subsequent cases at an earlier moment. Thus, step by step, was built up the obstetric art, and then arose a skilled band whose aid was demanded and relied upon when the emergency occurred.

In all history we find but little allusion to the art or any advances therein until the advent of Hippocrates, about 450 B. C. Up to this time as there was but little study of anatomy very little was known of the structure and relation of the parts to each other. Upon obstetrical subjects we find that Hippocrates wrote treatises entitled *De Natura Muliebri*, *De Mulierum Morbis*, and *De Superfætatione*, showing that in his time something at least must have been known of the diseases to which women are specially subject, as also upon the subject of twins or triple pregnancy. His views of conception and generation, though for many years regarded as correct, have been shown in the light of modern investigation to be very erroneous. Evidently, he had obtained in some way, possibly by the study of inferior animals, a knowledge of the ovum and its mechanical expulsion. Of course difficult delivery would be most thoroughly investigated, and we find also that he treats of the various ways by which the child presents for delivery and alludes to the different positions of the placenta or after-birth.

A singular belief which still retains a great deal of vitality is alluded to in his work entitled *De Natura Pueri*. This is that the fetus delivered at the seventh month of pregnancy has a better chance for life than one at the eighth month. A similar belief is also to be found in a rabbinical treatise of the third century, called *Midrash Rabbah*, a work on the book of Exodus by Rabbah, which says "a child can live at seven months and not at eight."

At this time it appears that when the midwife failed in delivering the woman the aid of the surgeon was demanded to accomplish it by force, and we find that Hippocrates counsels the use of means to break up the head of the child, and the extraction of the body by hooks, etc. The Cæsarean section, or opening the womb through the abdomen, would appear to have been an operation performed in very early times. Upon this subject, those who are desirous of investigating more thoroughly should read the valuable essay by Robert P. Harris, M. D., of Philadelphia. It has been believed, however, that in all cases such an operation was only attempted after the death of the woman, while in recent times we have records of instances where women have been subjected to it not once but twice, and have survived to a good age. This statement must be taken with some allowance, for we find in the Jewish *Mishna*, a collection written about A. D. 180, the question debated as to whether a woman was unclean who had the child taken by an operation from her side. Hence it is probable that cases had occurred where a mother had survived this ordeal.

About the VIIth century Paulus Ægineta appears to have practised midwifery, and we have quotations from him as to the delivery of the child where nature had been unable to accomplish the task. It is remarkable to what extent people were led to believe in multiple births, prodigies, etc. We can in the light of these days understand the reports of fetuses being passed by the bowels, from abdominal abscesses, or

even where portions had been ejected from the stomach. One would have supposed that a subject of so much importance, one connected so immediately with the growth of nations, would have attracted marked study in every quarter; but when we reflect upon the very low estimate placed upon women by barbarous nations, both of ancient and modern times, we find less cause for surprise. Slowly, as civilization progressed, as the means for learning were multiplied, we find a gradual advance in the study of obstetrics.

Perhaps one reason for the apparent neglect of this important branch of medical science is to be found in the fact that delayed, tedious labors are so exceptional, so rare that, except where disease or injury has caused deformity, but little aid would seem to be demanded. Not more than one case in every hundred can truly be regarded as other than a strictly natural easy labor, and this small number of cases are only delayed by causes generally capable of a natural solution. When we come to those which may be regarded as tedious or obstructed labors and those positively demanding instrumental interference, the proportion ranges notably greater, to one in 1000 or even more. This proportion is even greater in the case of nations where females live according to the laws of hygiene. Much of the obstruction, the delay in delivery, is due to the artificial mode of living among civilized nations, producing loss of general nerve power, exhaustion, and even deformity of organs, and thus destroying that wonderful exact proportion which always exists in the healthy female between the measurements of her organs and those of her child. Hence we see that as nations advance in the so-called arts of civilization they often degenerate at least bodily, and there arises a need for the study of methods by which to counteract the evil results which are sure to follow. Of these obstructions in labor we may instance cranial disproportions either by reason of deficiency of the mother or by excess of the child, requiring for delivery a resort to the operation called craniotomy or destruction of the child's head in order to reduce its size so that it may pass through the unyielding parts of the mother. This was spoken of by Hippocrates, and undoubtedly for many years was performed under circumstances where the child's life might have been preserved. Perhaps the greatest improvement in the obstetric art at any time was the invention of the forceps, which occurred about the middle of the seventeenth century. Undoubtedly the introduction of this instrument aided greatly in the practical instruction of physicians in the art of delivery, and at first it was regarded as the means by which every life was to be saved and every labor abridged. Indeed its use became universal, and at one time bid fair to do as much harm as good, in consequence of the utter ignorance on the part of the profession as to the proper employment of this aid and the appropriate cases in which to invoke it.

Now, we find the whole range of obstetrics enlarged; it was found necessary to study the development of the ovum, to follow it from the period of impregnation down to the moment of delivery; then came the anatomy of the parts, their relations to each other and to the fœtus; the physiological action of all the organs which were associated in the functions of child-bearing; finally, the pathological conditions of those organs and their interference whether in delivery or in the process of gestation. These studies need to be regarded as incident to the life of woman during her entire procreative period, which is generally regarded as ranging from the 15th to the 45th year. These limits have been ascertained as the average of an immense number of observations, although, as in other departments, we have exceptions either way. Incidents are on record of the delivery of a girl at her 11th year, and on the other hand of a woman at her 64th year. The most prolific period is from the 25th to the 30th year. Nor are we to regard cessation of the visible sign, menstruation, as a proof that the woman has

passed the age of becoming pregnant. Instances constantly occur where, owing to this cessation for a number of years, women have been announced as suffering with a tumor when the event proved that they were pregnant.

In consequence of such occurrences as this, and also because at many times necessity would arise to demand a positive knowledge as to whether a woman was pregnant or the reverse, the study of the signs of pregnancy has occupied all practitioners of midwifery for many centuries, and perhaps we may say for all time. Again and again has an infalible sign been announced, only to be shown as entirely without value. One of the most pronounced of these was the peculiar substance found in the urine of pregnant women and called Kiesteine. This was known as early as 1839, and for a time there existed no doubt that the needed test was at last discovered, but when other investigators found it in the urine of women who were not pregnant and finally in that of men, the fabric dissolved as in a dream and this test is now entirely abandoned. The only positive sign, and one which once heard is conclusive, is the sound of the foetal heart. This unfortunately can rarely if ever be heard until after quickening has occurred, and in many cases owing to other causes cannot be heard; hence, while its presence is positive, its absence is not a negative sign. The absence of the menstrual flow is usually a sign which leads to the search for contributory evidence, but this is very unreliable, as in some women menstruation never recurs during the period of childbearing; in others it may continue until the close of the latter months of pregnancy. Any one symptom then is not to be relied upon, but the presence of a number or the absence of others may be regarded as significant. Thus, when a woman of proper age is in apparent good health, the cessation of the menstrual flow, a gradual enlargement of the abdomen, with sickness or nausea in the morning, and a darkening of the areola around the nipple, would be symptoms to cause a strong belief that she was pregnant. If later, about 4½ months from the inception of these signs, there occurred at irregular intervals a peculiar feeling of fluttering or movement within the abdominal walls, known to women as the quickening, additional strength would be given to this belief. Another symptom of pregnancy which is regarded by many authorities as of special value is that of contraction of the womb at irregular intervals. This is noticed often at a very early period, and to many women is a positive proof that they are in the pregnant state. In the case of women, the walls of whose abdomen are not too much loaded with fat, this may be recognized by the physician by placing the hand upon the abdomen, and letting it remain for a short time. The sensation is then observed as though the uterine tumor slowly contracted beneath the hand. No decision should ever be made upon a few of these signs only, and it is always best to err on the safe side and act as though pregnancy were present than the reverse, as a number of unfortunate instances are on record where a failure to do this has been productive of mortifying results both to patient and physicians, and even death has followed.

The duration of pregnancy has been regarded by even learned authorities as very variable, but it is now generally conceded that about 300 days is the real limit, and by some governments this is the period allowed by law, where it may be necessary to decide the question.

During the first 15 or 16 weeks the cessation of pregnancy by the extrusion of the fœtus is called an abortion, after that it is a miscarriage. A belief which formerly was very common was that the fœtus was not endowed with life prior to the period of quickening. In fact, the credulous believed that this was the sign of the entrance of the soul, and that a delivery before that time was of no importance, and no criminality attached to any means which might be employed to

induce it. This highly dangerous belief led to the performance of the most outrageous practices on the part of those who did not wish to bear children. Fortunately, in the interest of humanity and the good of society, better instruction has promulgated the truth that the soul—the life—begins at the moment of conception, and the destruction of that life is equally criminal at any time. Ordinary natural labor should be regarded as a physical healthy act, and labor, whether that of miscarriage or abortion, is pathological, never occurring without more or less injury to the general system.

There are many diseases incident to pregnancy which become of importance as they may induce premature delivery, hence their study comes within the scope of the obstetrician. Of these may be mentioned excessive vomiting, occasionally going to such an extent as to bring on labor, or to so threaten the life of the woman as to bring up the question of the induction of labor for her relief; albuminuria, in which condition the blood becomes so loaded with injurious matter that the woman is often placed in a very critical condition, and is threatened with convulsions and death; disorders of the circulation and of the respiration; disorders of secretion and excretion; disorders of the nervous system; finally, serious displacements of the gravid womb.

Labor may be defined as the effort of the pregnant womb to extrude its contents, and it becomes natural or otherwise as it varies from the proper time for its occurrence, and as it is complicated or connected with disorders or disturbances which more or less interfere with its proper or speedy completion.

A natural labor rarely exceeds 24 hours in its duration. This is from the commencement of the dilatation of the mouth of the womb to the completion of delivery. Many accounts of labors of inordinate length are based upon a calculation from the inception of apparent labor pains. Instances are constantly occurring in which the labor has been regarded as extending over many days or even weeks. These are usually known as *false* pains, and are due to a variety of causes, as fatigue, excessive exertion, rheumatism, and the like. The first labor is usually longer in duration than any subsequent ones. So invariably is this the rule that it is generally safe for the obstetrician to predict a much shorter time and a more easy delivery in subsequent labors. Of course this alludes to such cases where it is known that there is no abnormal condition of the parts. Yet, even in cases where there has been great irregularity, nature unaided shows a wonderful power, spontaneous delivery having frequently taken place under the most untoward circumstances. This is the only means by which such monstrosities as the Siamese twins, or that more recent one, the double woman, could have been delivered alive and undivided.

At present the art of obstetrics has arrived at such a stage that the skill of the obstetrician is able to deliver alive and with safety to the mother many infants who otherwise must inevitably have perished, and perhaps have involved the mother, either causing her death or permanent invalidism. This is shown by the great success which now follows the operation of Cæsarean section; the scientific employment of the forceps; turning; and the induction of premature labor; the prevention or relief of puerperal eclampsia, etc. The study of the art of obstetrics is now regarded as of equal importance with the other branches of medicine, and is one of the seven fundamental branches, taught by a separate professor in all medical schools.

The best works for consultation in the study of obstetrics are those of Leishman, Churchill, Tarnier's Cazeaux, etc.

(W. B. A.)

O'CALLAGHAN, EDMUND BAILEY (1799-1880), antiquarian, was born at Mallow, Ireland, in 1799. He went to France in 1821, and to Canada in 1823. He

began the practice of medicine in 1827, but became editor of the *Montreal Vindicator* in 1834. After the insurrection of 1837 he removed to New York, and in 1848 he was appointed keeper of the historical manuscripts in the office of the secretary of state at Albany. In 1870 he removed to New York city, where he continued his historical labors till his death on May 27, 1880. He had edited for the State the *Documentary History of New York* (14 vols., 1849, sqq.); *Documents Relating to the Colonial History of New York* (11 vols., 1855-61); *Historical Manuscripts Relating to the War of the Revolution* (1868), and other works. He also published a *History of New Netherlands* (2 vols., 1845-48).

OCCUM, SAMSON (1723-1792), Indian preacher, was born near New London, Conn., about 1723. He was educated at Rev. Ebenezer Wheelock's Indian school, at Lebanon, Conn., and afterwards taught school at Montauk, L. I. In 1766 he was taken to England by Rev. Dr. Whitaker, who went to raise funds for the Indian schools. These funds became the endowment of Dartmouth College (*q. v.*). Occum after his return preached in Long Island, chiefly to the Indians. He wrote an account of the Montauk Indians and a hymn, "Awaked by Sinai's Awful Sound." He died at New Stockbridge, N. Y., in July, 1792.

OCEAN LIFE in most of its forms has been fully treated in the *ENCYCLOPÆDIA BRITANNICA*. This article treats briefly of the important discoveries that have been made of recent years concerning the life-forms of the deep sea, the unexpected and surprising information that has been attained by careful dredging under scientific direction. It was long believed, indeed, that the depths of the ocean were quite incapable of sustaining animal life from lack of the necessary conditions of food and light, and from the immense pressure of the water at great depths, and it was argued that the lowest limit of penetration of light, which was believed to be about 40 or 50 fathoms, probably formed the lower boundary of ocean life. Late research has disproved all this. It is now known that light penetrates the water to a considerably greater depth than was supposed, and that animal life of high forms exists far below the utmost possible limit of light penetration.

Scientific efforts to dredge the ocean bottom began in the last century, but none of these extended to great depths, and it was not until recently that dredging below the 100-fathom line was attempted. The earliest revelation as to the life-forms of the deeper ocean was made in 1819, when Sir John Ross, during his first Arctic voyage, sounded to a depth of 1000 fathoms, and brought up strange forms of life attached to his sounding-line. Yet it was not till 1838 that a strong interest in deep-sea dredging began to display itself, Dr. R. Ball, of Dublin, in that year devising a greatly improved form of the naturalists' dredge. Previously a square-mouthed dredge had been used, with a purse-net attached to hold the collections. He constructed his dredge with an oblong, narrow mouth of about 12 by 4 inches, and attached scraping edges to both sides, so that it might do its work no matter how it fell. In the same year the Wilkes exploring expedition did some deep-sea dredging, while in 1840 Sir James Ross dredged to a depth of over 400 fathoms, and proved that the sea was prolific at that depth. Many others, both in Europe and America, followed this example, but no greater depth was attained till 1860, when in the voyage of the *Bulldog*, sent to examine a proposed northern cable route, the sounding-line brought up 13 star-fishes from a depth of 1260 fathoms. These were attached to a part of the line that had lain for some time on the bottom, but many naturalists considered it possible that the animals might have clasped the line on its way up. A telegraph-cable, which had been laid across the Mediterranean from Sardinia to Africa, and which was lifted in 1861, was found to be covered with animals in parts that had been 2000 fathoms deep.

This was an evidence of the prevalence of life at that depth that could not be readily set aside.

Yet despite the many indications that had been perceived of the existence of a deep-sea fauna very little impression was made on the minds of naturalists, and, up to 1866, it was generally believed that the field below the 300-fathom line was barren of animal life. This theory was advocated by Edward Forbes, as a result of his researches in the Ægean Sea, and was generally accepted, the facts to the contrary being quietly ignored. The Mediterranean, indeed, is somewhat barren at great depths, though the existence of deep-sea life there has since been fully demonstrated.

Before this date, in fact, animal life had been shown to exist off the coast of Spitzbergen at depths of 1000 and 1400 fathoms, and the Profs. Sars, father and son, had made a series of systematic researches at considerable depths off the Norwegian coast. These were followed by similar researches made in 1867 by Mr. L. F. de Pourtales, of the U. S. coast survey. His explorations were made off the southern coast of the United States, and reached a depth of 680 fathoms. In the succeeding year the *Lightning* was sent out by the British admiralty to dredge, under the scientific direction of Dr. Carpenter and Prof. C. Wyville Thompson. In this expedition a depth of 650 fathoms was reached. The better adapted *Poreupine*, sent out in 1869, dredged to a depth of 1470 fathoms off the coasts of Ireland and Scotland, and, in her second voyage, reached over 2400 fathoms in the Bay of Biscay. At this great depth (2½ miles) life was found to exist abundantly, and animal forms from the protozoa to the mollusca were brought up.

During December, 1871, and in the early months of 1872 the coast-survey steamer *Hassler* conducted a series of deep-sea dredgings, under the scientific direction of Louis Agassiz. In 1871 the U. S. Fish Commission was organized, and from that time forward made deep-sea exploration an important part of its labors, under the direction of Prof. A. E. Verrill, who had been engaged in labors of this kind since 1864.

But the most important exploring expedition of this kind that has been made up to the present time is that of the *Challenger*, a vessel sent out in 1872 by the English government for the purpose of dredging the depths of the great oceans. The *Challenger* traversed the Atlantic and the Pacific in various directions, crossing the former ocean five times, her total length of voyage being 69,000 miles. She returned in May, 1876, bringing an exceedingly rich zoological collection, which has been carefully worked up by noted specialists, whose labors are represented by more than 30 bulky volumes. On three occasions the *Challenger's* dredge reached a depth of over 3000 fathoms (about 3½ miles), and in every case living forms were brought up from this extreme depth. The deepest sounding made was 4575 fathoms. For further particulars see article DREDGE in ENCYCLOPEDIA BRITANNICA.

Since the date of the *Challenger* voyage several important dredging explorations have been undertaken. Norwegian expeditions were sent into the northern seas in 1876, 1877, and 1878. The Germans, the Italians, and the French followed the same example, the voyage of the French ship *Talisman*, in 1883, from the coast of Morocco to the Azores and the Sargasso Sea, having yielded highly valuable results. The Americans have been equally active. From 1877 to 1880 the steamer *Blake* was engaged in deep-sea explorations in the region of the West India islands and the Gulf of Mexico. These researches, under the scientific direction of Alexander Agassiz, were fruitful in results, a summary of which has been recently given to the world in two highly interesting volumes. In the explorations of the *Blake* important modifications of the dredging-apparatus were made. The dredge used for deep-sea work is necessarily made much larger than the original Ball dredge, being about 4½ ft.

long and 1½ ft. wide. In addition to the collecting-bags long strands of teased-out hemp attached proved very serviceable in entangling star-fish, corals, and other spiny inhabitants of the great deep. The dredge, however, is now in part superseded by the beam-trawl, which under certain circumstances proves more serviceable. A trawl, of about 15 ft. in length, was used occasionally by the *Challenger*, and a similar implement is used almost exclusively by the United States Fish Commission. The improvements effected in the *Blake* explorations were to make the ocean-trawl reversible, to alter the dredge so as to prevent it burying itself in the mud of soft bottoms, to substitute wire for hempen rope, and to modify the methods of hauling and reeling, these various changes adding greatly to the efficiency of the apparatus.

In 1884 the steamer *Fish-hawk* was built for the dredging and hatching operations of the Fish Commission, but her small size unfitting her for deep-sea work she was superseded by the *Albatross*, the best-equipped dredger for deep-sea work in existence. In her first voyage, in 1883, this vessel made a successful trawl in the Atlantic of 2949 fathoms. At present (1888) the *Albatross* is engaged in an extended voyage of exploration, and is employed in dredging in the Pacific, off the western coast of America. Very interesting results may reasonably be expected from this expedition.

This rapid survey of the history of the exploration of the ocean depths may be followed by an equally concise description of the zoological results. These have been extensive and important, and have altogether changed the views of naturalists as to the limits of ocean life. It is now known that instead of living beings being confined to the littoral zone and to the ocean surface, they exist in abundance at the greatest depths yet examined, every order of life below the air-breathers being represented, and the variety of species being possibly as great as that on the surface. It must be borne in mind that what has so far been done is but a beginning in this work. The dredge has swept at the most a few square miles of an ocean-floor represented by millions of square miles, and exploration must be prosecuted for centuries ere any complete conception of its zoology can be attained. So far no part of the ocean is better known in regard to its marine products than that adjoining the Atlantic coast of the United States. The diligent labors of explorers have given us much knowledge concerning both the littoral and the deep-sea life of this region of the waters.

Among the specimens brought up by the dredge are representatives of every class of marine life, including corals, sponges, echinoderms, annelids, crustacea, mollusks, and fishes, all of which, except the latter, exist at the greatest depths reached by the dredge. Fishes have been captured at a depth of 2900 fathoms, and probably reach as low as the others. As to the vast mid-stretch of the ocean, between the range of surface-forms and the bottom, nothing definite is known concerning its life-forms. There is some reason to believe that life is confined to the surface and the bottom regions, and that the intermediate zone is barren; but the researches as yet made have been insufficient to determine this satisfactorily. The most abundant organic deposits on the ocean bottom are made by minute creatures, the Radiolaria and Foraminifera, whose remains form a thick layer of calcareous ooze, which is inhabited abundantly by the shelled animals. (See PACIFIC OCEAN in ENCYCLOPEDIA BRITANNICA.) In those regions of the bottom wanting this ooze the animal forms are chiefly those without shells, such as the Annelida and the Holothuroidea.

The variety of animal forms that has been brought up from the ocean bottom is far too great for any attempt to particularize, and we can but give a general description of their characteristics. At first it was imagined by many that the deep sea would yield to us



- | | | | | | |
|-----------------------------------|---------------------------------------|-----------------------------------|-----------------------|----|----|
| 22 | 21 | 20 | 19 | 18 | 17 |
| 1. <i>Sclerothamnus Clausii</i> . | 5. <i>Halosaurus maerachir</i> . | 9. <i>Actinotheca pellucida</i> . | 13. <i>Pentagona</i> | | |
| 2. <i>Drymonema Victoria</i> . | 6. <i>Psychropates buglossa</i> . | 10. <i>Melonocetus Johnsoni</i> . | 14. <i>Aveturus</i> . | | |
| 3. <i>Hyalonema Sieboldii</i> . | 7. <i>Nematocarcinus gracilipes</i> . | 11. <i>Pheronema Carpenteri</i> . | 15. <i>Styracaste</i> | | |
| 4. <i>Semperella Schultzii</i> . | 8. <i>Neostoma bathyphilum</i> . | 12. <i>Nymphon Robustum</i> . | 16. <i>Onciopho</i> | | |
| | | | 29. <i>Boltemia</i> | | |

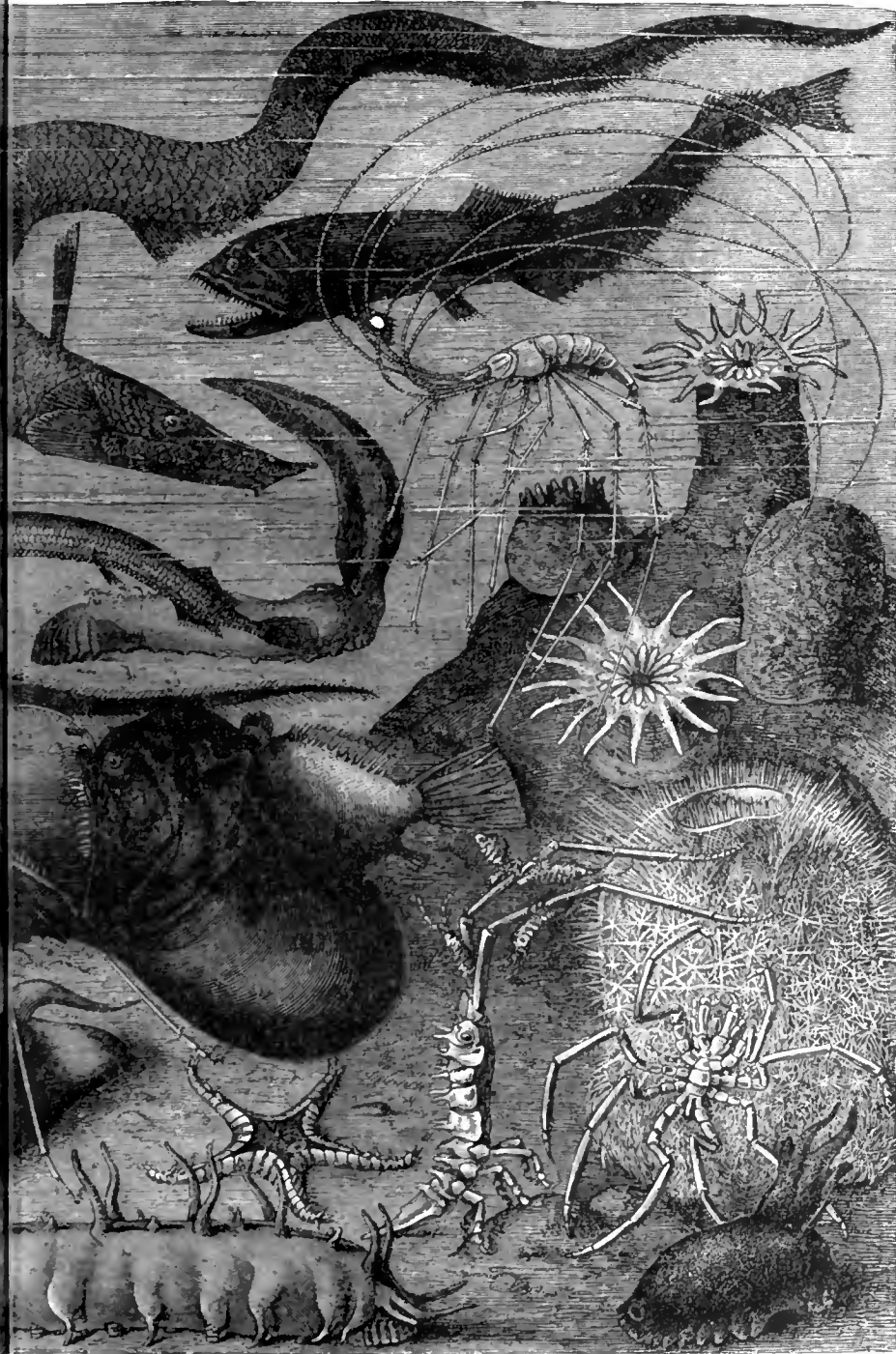

- | | | | |
|--------------------------------|-------------------------------|-------------------------------|------------------------------------|
| 16 | 15 | 14 | 13 |
| <i>Euphronides Talismani.</i> | <i>Pectanthis asteroides.</i> | <i>Chondrocladia virgata.</i> | <i>Eustomias obscurus.</i> |
| <i>Colossendeis Titan.</i> | <i>Rhopalodina Heurteli.</i> | <i>Hymenaster vex.</i> | <i>Eurypharynx pelecanoioides.</i> |
| <i>Ypsilothuria attenuata.</i> | <i>Dactylocalyx pumiceus.</i> | <i>Stomias bon.</i> | <i>Macrurus globiceps.</i> |

near relatives of the animals of past geological eras, it being argued that the homogeneous temperature and conditions of the ocean bottom would be favorable to the persistence of antique forms. This theory has not been sustained by the facts. While indications of antiquity in some of the forms have been perceived, the great mass of them approach the surface forms in character, and present indications of originating in the descent of such surface forms. The range of deep-sea fishes is, indeed, very great. Certain forms which live in shallow water in some regions have been dredged from the greatest depths in others, and the presumption is that littoral forms are capable without great difficulty of adapting themselves to the widely different conditions of deep-sea life. This may serve also to explain the variety of colors of abyssal forms. The fishes are usually of dark color, though some are pink or silvery; but many of the crustaceans are of brilliant red hues, and the mollusks display considerable variety of coloration. Many of these animals, moreover, display features of protective mimicry, and others have burrowing habits. It is difficult to believe that these characters have arisen from the exigencies of a life passed in regions of darkness. They seem rather to indicate that these animals are descendants of surface forms, and have preserved some of their original features and habits.

There are two further things to consider: the food-supply of these animals, and the modifications in structure and mode of life necessarily resulting from life in a region destitute of sunlight and subjected to enormous pressure. In regard to food the active carnivorous forms, which include all the fishes, find an abundant supply in the more sluggish creatures which exist in such numbers. But the basis of all animal life must be a vegetable diet, and there is no indication of any plant forms growing on the ocean bottom. Plants need sunlight, if animals do not, and can only exist within the reach of its influence. Yet it is not difficult to ascertain the primary source of the deep-sea food-supply. The surface of the ocean is crowded with life, in extraordinary abundance and variety. In addition to the pelagic animals, minute algæ exist abundantly in the surface waters, and form the food of many of the animal forms. This pelagic life remains on the surface only during vitality. After death it immediately begins to sink, and there is probably a continuous rain of dead animals and plants descending with some rapidity to the ocean-floor. These forms possess considerable nutrient material, which probably decomposes very slowly, and long remains fit for food. It forms, as Dr. Carpenter remarks, a sort of broth, which collects on the bottom, and furnishes an abundant food-supply for the sluggish animals, which in their turn yield food to the more active carnivora. It is not difficult, therefore, to understand the existence of an extensive fauna in a region destitute of plants. The plant-life of the surface is the basis of the food of deep-sea animals.

The conditions of life in the depths of the ocean are remarkably unlike those existing at the surface. The absence of sunlight is one radical distinction, and the great pressure of the water is a second. At a thousand fathoms this pressure is about one ton to the square inch, and at the lowest depths reached it must be far more enormous. Yet there seems to be no difficulty in sustaining this pressure. The tissues of the animals are permeated with fluids, and the pressure, thus equalized, is probably not felt. Yet on bringing them to the surface the effect of the sudden diminution of pressure is clearly seen, particularly in the fishes, which often come up in a very dilapidated condition. The tissues of the deep-sea fishes are, indeed, very fragile. The bones are often light, fibrous, and nearly destitute of calcareous material, so that they may be penetrated by a sharp needle without injury to its point. The muscular system is also often feebly developed, the muscles being thin and the con-

nective tissue loose and feeble. It is probable that the pressure may have something to do with these conditions, the loose tissues being compressed so as to render them serviceable for swift and vigorous motion.

In addition to this characteristic of the tissues the deep-sea fishes present many abnormal conditions of structure, in some cases the head or the jaw being enormously developed, while the body is reduced to a ribbon form. Yet these strange creatures do not belong to new orders, but are simply modified varieties of surface types. Their most striking modification, however, is that due to the absence of natural light in their habitat. Many of them are organized so as to yield an artificial light—to serve as lamps in their dark abode—while a corresponding variation in their eyes has taken place. In certain cases their eyes are atrophied. Many of the gasteropoda, and some fishes and crustaceans, have thus become blind. These belong generally to antique types, and they often possess tactile organs of gigantic size, touch supplying with them the place of vision. But as a rule the eyes of deep-sea animals are of increased size, and sometimes are developed to huge proportions, as if to enable them to see well under conditions of very feeble illumination.

The fact is that the habitat of these animals is far from being the region of perpetual darkness which might naturally be supposed. Very many of the animals are self-luminous, this phosphorescence existing alike in fishes, echinoderms, crustacea, polyps, mollusks, and annelids, the light yielded being perhaps sufficient to diffuse a feeble illumination through the thickly peopled regions of the ocean cavern. The contents of the trawl, when drawn to the surface, are often brilliantly phosphorescent, many highly luminous anthozoa, ophiurans, hydroids, crustaceans, etc., yielding their quota of light. The bottom seems to be covered in some localities by forests of gorgonians, which become luminous when disturbed by currents, thus enabling the animals creeping or swimming through them to see for some short distance. It is supposed that this light may be protective, and intended to warn foes not to come too near the dangerous lasso cells of the well-armed light-givers.

The phosphorescent organs are not equally distributed among the various families of deep-sea fishes, though those in which they are absent have usually a well-developed muciferous system, the abundantly secreted mucus yielding the necessary luminosity. The phosphorescent organs vary considerably, and are divided into a number of classes. In one case the sides of the fish are covered with innumerable minute tubercles, raised above the skin, and supposed to be light-givers. Secondly, we find tubercles of larger size and less in number, which occur on the head as well as on the body. Thirdly, eye-like spots appear, white in preserved specimens but red or green in life. These are ranged at regular intervals along the lower sides of the body, and also occur on the head. Fourthly are large, flat, round spots of a mother-of-pearl brightness, which also extend in rows along the lower sides of the body and head, while isolated ones appear in other localities. Fifthly, more or less diffuse patches of a white glandular substance, of varying thickness and irregularly placed on the body, exist. There are two or three other conditions and arrangements, though the above given are the most important, and are sufficient to show that an extraordinary provision for lighting up the depths of the ocean has been made. This provision, with the unusual eye development, must make the deep-sea a much more agreeable place of abode than would naturally be expected. It is probable that these luminous organs are at the command of the fish, and are used to aid them in search of their prey. The organs near the eyes, for instance, are supposed to act on the principle of a bull's-eye lantern, to project a beam of light ahead. In other cases where the luminous organs are at the extremities of barbels

or tentacles their probable use is to attract unsuspecting prey.

Much more might be said in regard to these remarkable discoveries, but the above may serve as an epitome of their leading features. They have immensely widened the area of zoological science, and opened a field of research which cannot become exhausted for centuries to come, and which may yield in the future marvels of life which will serve to greatly modify our conclusions as to nature's powers and possibilities.

(C. M.)

O'CONNOR, CHARLES (1804-1884), an American lawyer, was born in New York city, Jan. 22, 1801, his father having emigrated from Ireland in 1801. Admitted to the bar in 1824, his untiring industry was soon rewarded with a large practice. His successful management of the Forrester divorce case gave him a wide reputation. He was also employed in the noted will cases of Lispenard in 1843, of Parrish in 1862, and of Jumel in 1872. In 1855 he was appointed U. S. district attorney for New York, and in 1846 and 1864 he was a member of the Constitutional Convention of that State. In politics he was an extreme Democrat, and during the civil war he favored the cause of the South. At its close he was the leading counsel for Jefferson Davis when indicted for treason. His greatest legal efforts were made in the prosecution of William M. Tweed and his associates for the recovery of the public money which they had embezzled from the city of New York. The partial result he described in a volume called *Peccation Triumphant, being the Record of a Five Years' Campaign against Official Malversation, 1871 to 1875*. Yet O'Connor continued the campaign until he achieved substantial success, though not in the measure he desired. In 1872 he was nominated for President against his earnest protest by a small convention at Louisville, which was dissatisfied with Greeley as the Democratic candidate. In the succeeding campaign O'Connor received only 21,559 votes. In 1881 he removed his residence from Fort Washington, N. Y., to Nantucket, Mass. Still erect in stature and vigorous in health, he carried on professional work in New York city. On a trip thither, in April, 1884, he caught cold and he died at Nantucket, May 12. He was married in 1854, but had no children. His professional success was due to his indefatigable devotion to clients' interests, his thorough mastery of all the details of the most complicated cases, and his clear presentation of the law and facts of each. Though inclined to wit and humor at times, he did not permit it to diminish the force of his arguments. His large collection of cases and opinions was bequeathed to the Law Institute of New York, of which he had been president since 1869.

OERSTED, HANS CHRISTIAN (1777-1851), a Danish physicist, was born at Rudkjöbing, on the island of Langeland, Aug. 14, 1777. He was the son of an apothecary, and at an early age began his experiments. In 1799 he received the degree of Ph. D. at the University of Copenhagen, his thesis being *Architectonics of Natural Metaphysics*, a philosophical consideration of the laws of the natural world. While engaged as an apothecary in 1800, Oersted made some discoveries in galvanic electricity. In 1801 he travelled in Holland, Germany, and France, and on his return in 1803 lectured at Copenhagen on electricity and kindred sciences. In 1806 he was made professor of natural philosophy, and his lectures attracted much attention. His thoughts had long been directed towards the identity of electricity and magnetism. In 1812, while in Germany, he published a treatise tending to that conclusion, and at last, in 1819, he succeeded in proving the fact. This great discovery gave him a foremost place among the scientific men of his time, and foreign societies bestowed on him numerous marks of honor. His labors to popularize science among his countrymen resulted in the establishment of a polytechnic school at Copenhagen, of which he was director from 1829.

He also founded the Magnetic Observatory of Copenhagen. In 1850 the fiftieth anniversary of his doctorate was celebrated with a national jubilee. He died at Copenhagen, March 9, 1851. His most important works were a *Manual of Mechanical Physics* (1809; 2d ed., 1844); and *The Soul in Nature* (1806; English translation, 1852).

His brother, ANDERS SANDOE OERSTED (1778-1860), was an eminent jurist, and in 1853 became prime minister of Denmark, but was driven from power in 1854 and impeached for violation of the constitution, but finally acquitted. He was the author of some philosophical works.

OFFICE, as a legal term, denotes a right and correspondent duty to exercise a public or private trust or employment, and to take the fees and emoluments belonging to it. Offices may be variously classified. *Judicial* offices are those which relate to the administration of justice. *Military* offices are such as are held by soldiers and sailors for military purposes. *Ministerial* offices are those which give the officer no power to judge of the matter to be done, and require him to obey the mandates of a superior. *Political* offices are such as are not connected immediately with the administration of justice or the execution of the mandates of a superior officer: *e. g.*, those of President of the United States, members of Congress, etc.

In England some offices may be granted to a man in fee, or for life, as well as for years and at will. In the United States the Constitution or laws of the State provide for the duration of the office, which is never more permanent than during good behavior. Offices in England are either public, which affect the people generally, *e. g.*, magistrates; or private, which concern particular districts belonging to private individuals, *e. g.*, bailiffs. In the United States all offices are deemed public, though those of presidents of banks and directors of corporations are in the nature of private offices. The statutes of 5 and 6 Edw. VI. c. 15 made the buying and selling of offices a misdemeanor, to be punished also with the loss of the office. Its provisions have been enacted by several of the United States; its object being to prevent corruption in office, it does not apply to the fair and necessary appointments of deputies with a reasonable allowance. If the salary be fixed, a deputation of the office, reserving a sum less than the salary, is not illegal; so if the emoluments be uncertain, the deputy may agree to pay over a proportion of what he receives. If, however, the fees are uncertain, and the deputy agrees to pay a certain fixed sum, without restricting it to the amount received by him, it is a sale within the statute. It has been decided by the federal courts, as well as by those of several of the States, that an agreement by an applicant for office to divide the fees with another applicant if he will withdraw and aid the former to obtain it is void. A judicial office must be exercised by a person of skill and experience in the duties pertaining thereto; it must also be exercised in person, as a judge cannot delegate his authority to another.

Under the Constitution of the United States, Art. VI, § 2, no Senator or Representative can hold office under the United States during his term. By accepting such an office he forfeits his seat.

By an act passed during the administration of Pres. Monroe and still in force, the term of office of U. S. collectors and other executive officers, including certain grades of postmasters, is for four years, though they may be removed sooner by the President. During the political struggle between Pres. Johnson and the Republican majority of Congress, an act was passed on March 2, 1867, providing that every person holding any civil office to which he had been appointed by and with the advice and consent of the Senate should be entitled to hold such office until a successor should in like manner have been appointed and duly qualified. It also prescribed that while the President might remove or suspend an officer for cause, yet the

Senate should be judge of the cause and have power to reinstate the officer independently of the President, and that officers appointed by the President during the recess of the Senate should draw no salary until the Senate had given its consent. This act also provided that the secretaries of state, of the treasury, of war, of the navy, and of the interior, the postmaster-general and the attorney-general, should hold their respective offices during the term of the President by whom they have been appointed and for one month thereafter. This Tenure of Office Act was vetoed by Pres. Johnson in an able message, but the bill was passed over the veto by a vote of 35 to 11 in the Senate and of 133 to 37 in the House of Representatives. Pres. Johnson's attempt to remove E. M. Stanton from his office as secretary of war in 1868 led to his impeachment, a movement which failed through its inability to secure the necessary two-thirds vote in the Senate.

When Pres. Grant took office on March 4, 1869, he found the discharge of his duties greatly hampered by this act, and on March 9th Gen. B. F. Butler introduced a bill in the House of Representatives repealing this act. The repeal passed the House by a vote of 138 to 16, but the Senate proposed a substitute by which the President was allowed to suspend any officer without showing a cause and to nominate a successor. Nominations could be made until the Senate should confirm, but in the failure of the Senate to confirm the suspended officer would be restored. Owing to the difference between the two Houses the modification of the act was all that could then be obtained. Its repeal was asked for in later years by Pres. Grant, Hayes, Garfield, and Arthur, on the ground that it obstructed the faithful and efficient administration of the government, but the modified act remained in force until 1886.

The President has now freedom to exercise that salutary constitutional authority over appointments and removals which had been the uniform rule since the formation of this government until 1867. This extensive grant of power to the executive had been carefully considered by the framers of the Constitution and deliberately adopted by them, and it has since had the approval of Chief-Justice Marshall and other eminent expounders of constitutional law. (T. R.)

OGDEN CITY, the county-seat of Weber co., Utah, is at the confluence of the Weber and Ogden Rivers, 37 miles N. of Salt Lake City. It is the terminus of the Union Pacific, the Central Pacific, the Utah Central, the Denver and Rio Grande (narrow gauge), and the Utah and Northern Railroads. For these roads a union passenger depot is provided. The Weber River here passes through the Wahsatch Mountains, and the city is at an elevation of 4340 ft. Ogden Cañon is 7 miles long, with a total fall of 450 feet, thus affording good water-power. There are two bridges over the Weber and one over the Ogden River. Ogden has 5 hotels, 3 national banks, 1 semi-weekly and 2 daily newspapers, 6 churches besides the Mormon tabernacle and ward meeting-houses. The six public schools are controlled by the Mormons, but each denomination has a school of its own. The industries comprise an iron-foundry, flour-, saw-, and planing-mills, two breweries, and factories producing brooms, boots and shoes, woollen goods, and vinegar. In Ogden cañon there are large powder-works and also the plant of the electric light for the city. The streets are wide and well kept, the business blocks substantially built. Ogden has a park-square, water-works, and gas-works. Its property is assessed at \$2,158,000, which is half the true value. The city's debt is \$21,000, its yearly expenses are \$41,000, and its revenue is still greater. It was settled in 1848 by Mormon agriculturists and incorporated in 1859. Its population in 1880 was 6069, but it has since greatly increased.

OGDENSBURG, a city of New York, in St. Lawrence co., is on the St. Lawrence River, at the mouth

of the Oswegatchie. It is the terminus of three railroads, and has also steamboat lines. Its principal edifices are the Roman Catholic cathedral, the U. S. government building, and the Seymour hotel. It has a national bank, 8 churches, graded schools, 1 daily and three weekly newspapers, a large grain-elevator, flour- and lumber-mills, and leather-factories. The village, founded by French missionaries, did not receive its present name until 1817, when it was incorporated. It was made a city in 1868. Its population in 1880 was 10,341.

OHIO is, by the census of 1880, the third of the United States in population and wealth. See Vol. XVII. It was the first State created from the p. 734 (p. 754 North-west Territory. There is some Am. Rep.). conflict among authorities as to the date of its admission to the Union, that generally given being February 19, 1803, while others maintain that Ohio became one of the States of the Union in 1802.



In 1802 it was decided that the territory now comprised in the State of Ohio had a population sufficient to warrant the petitioning of Congress for its admission as a State. Congress passed a bill, approved by the President on April 30, 1802, authorizing the inhabitants of this Territory to form a constitution and

State government under such name as they deemed proper, said State to be admitted to the Union on the same footing as the original States. This act also authorized all male citizens, residents in the Territory, of certain prescribed qualifications, to choose representatives to form a convention which was to convene at Chillicothe on the 1st Monday in November, 1802, and determine whether it was expedient to form a constitution and government, and if so, to form them, but if not, to provide for calling a second convention for that purpose. The act also provided that until the next census the new State should be entitled to one member in the House of Representatives. Neither Legislature or convention nor even the people were asked to pass upon the question of entering into a State government, the sole function of the electors being to vote for the members of the convention as prescribed by Congress. The convention assembled in the following November, and before its adjournment, on Nov. 29, framed a constitution. The following winter Congress passed an act entitled "An act to provide for the execution of the laws of the United States within the State of Ohio," which was approved by the President on Feb. 19, 1803. There has been considerable discussion as to which of the three dates can be properly given as that of the admission of Ohio as a State. Some claim that April 30, 1802, the date of the enabling act, was the date of admission; others that Nov. 29, 1802, the date of the adjournment of the Constitutional Convention, was the date, while the majority of those considered authority declare that the date of the approval of the act providing for the execution of the laws of the United States within the State of Ohio, Feb. 19, 1803, is the proper date of admission. The fact is that Ohio was never in set terms admitted to the Union, although the act of Feb. 19, 1803, after giving the history of what had preceded in the organization of the State, says: "Whereby the said State has become one of the United States of America."

Ohio is situated between 38° 27' and 41° 57' N. lat. and between 80° 34' and 84° 49' W. long. Its area is 40,760 square miles. The greatest length of Ohio from north to south is about 210 miles, and the greatest breadth from east to west about 225 miles. The native as well as the foreign-born population of Ohio has increased rapidly since the census of 1880. There

were in 1887 in the State 69,073 births and 29,180 marriages. The number of deaths was 30,818. There were naturalized in 1887 in the State 5729 voters. Of these 3188 were natives of Germany, 601 natives of Ireland, and 288 natives of Austria.

Physical Features.—Since the year 1884 a new chapter has to be added to what was then stated regarding the physical features and resources of Ohio. The natural resources of the State are now known to include a bountiful supply of the combustible fluid known as natural gas. Since the town of Findlay, Hancock co., in the north-western part of the State, was first settled natural gas was known to exist there in small quantities. The spring-water was charged with sulphuretted hydrogen, and in 1836 a vein of gas was struck at a depth of ten feet in excavating for a well. Although this readily ignited, no thought of using it for economic purposes resulted in any further search for the gas until, in March, 1884, a company was organized at Findlay to bore for natural gas. In the first successful well gas was found in large quantities at a depth of 1092 feet below the surface, flowing in a volume of from 200,000 to 300,000 cubic feet a day. The record of the drilling of this well is given as follows:

Drift.....	8 ft.
Upper limestones.....	237 "
Shales, red, gray, and brown.....	847 "
Lower limestone or gas rock.....	1092 "

This was the first discovery of the fact that gas was stored in the Trenton limestone beneath Findlay in sufficient quantities to be of great value as fuel for manufacturing and domestic use. This was rapidly followed by the sinking of other wells, one after another proving successful, and a sufficient supply of gas soon being tapped to furnish fuel for the houses and factories of a metropolis.

The excitement attendant was similar to that on the discovery of petroleum in Western Pennsylvania. Real estate advanced in value, new manufactures were projected, and in a few years the population of Findlay increased from 5000 to nearly 20,000. The Findlay gas-field extends a dozen miles north and east of the city.

But the Ohio supply of natural gas is by no means confined to the Findlay field. Bowling Green, Carey, and many of the other towns in the same part of the State were nearly as successful as Findlay in drilling for the natural gas, the history of Findlay being substantially that also of other towns in North-western Ohio. In other parts of the State, in fact in every part of it, wells have since been drilled with more or less success. In North-western and Western Ohio success has, as a rule, attended these efforts. In Central Ohio Lancaster obtained a good supply of gas. A system of piping the gas to cities, whose efforts to secure it by drilling have been unsuccessful, has been inaugurated.

The great merit of the natural gas as a fuel is its cheapness and high quality as a heat-yielding combustible. In localities where it is present it has superseded coal, as the cost of obtaining it after the first drilling and piping is almost inappreciable, and it can be furnished to consumers at a very slight expense. Supposed at first to be stored in the Trenton limestone, it has since been found in the Clinton limestone, and at some points in Berea grit.

The specific gravity of the Ohio natural gas is .566. The depth at which it is found beneath the surface varies in different fields, the successful wells in the Findlay fields varying from 1100 to 1650 feet in depth. The strongest wells obtain their gas in Trenton limestone. At Cleveland the natural gas was obtained after drilling over 1800 feet. Scientists differ as to the likelihood of the supply becoming exhausted, but Ohio wells from which gas has been burned in quantities for

two or four years still flow with unabated pressure. Its discovery has given a new impetus to manufacturing industries in Ohio.

At Lima, Allen co., drilling for natural gas in the spring of 1885 resulted in developing new oil-fields, petroleum coming from the Trenton limestone in large quantities. This was the opening of the development of the Lima oil-field, which has since proved very productive.

Agriculture.—There are at least two-fifths of the persons engaged in any occupation employed in agriculture, the leading industry of Ohio. There are about 10,000,000 acres cultivated, and in 1886 nearly 40,000,000 bushels of wheat, 90,000,000 bushels of corn, and in the neighborhood of 190,000,000 bushels of all cereals were produced in the State. The average production of wheat for the last five years has been 11.86 bushels per acre, and of corn 33.8 bushels per acre. The products of orchards and dairies are also prolific. The annual production of wool in 1886 and 1887, though slightly less than in preceding years, was about 20,000,000 pounds, Ohio holding the first rank in the wool-producing States. The number of sheep in 1887 was 4,105,177, and in 1888 was 3,739,449. In 1888 the number of horses was 786,549; cattle, 1,612,726; mules, 25,189; hogs, 1,629,616. Ohio ranks next to Illinois in thoroughbred cattle, and is one of the largest pork-producing States. Agricultural implement manufacturers in this State turn out one-fourth the annual product of the United States.

Manufactures.—Ohio is one of the leading States in the number of manufactures, the amount of annual manufactured product, and number of men employed in manufacturing industries. The manufacturing concerns of the State include nearly every form of industrial enterprise, from rolling-mills to glass-factories. In Cleveland are located many large rolling-mills and iron-factories, the immense works of the Standard Oil Company employing three thousand men, with a capital of millions invested, and numerous other large factories of different kinds. In Akron, Canton, and Springfield are large agricultural machine and implement concerns, also employing thousands of men. This State furnishes at least one-fourth of the agricultural implements of the country. In Findlay, in the north-west, in East Liverpool, and in other portions of the eastern part of the State are large glass-factories, the latter region being also the seat of many large potteries. Columbus has immense carriage-factories, rolling-mills, and agricultural implement works. Cincinnati has many large manufactories of different kinds, besides being one of the leading cities of the country in the pork-packing industry. There are over 7000 industrial establishments in Ohio, employing 200,000 men and 30,000 women, with a capital of over \$200,000,000. The value of the annual product of these manufactures is \$400,000,000. Statistics show that the number of weeks in which these manufactories are in operation during the year averages 47.

Railroads.—Ohio is covered with a net-work of railways, all the principal towns and cities in the State being now on the lines of railroads and all the eighty-eight counties being crossed and recrossed by railroad lines. In the twelve years between 1876 and 1888 4000 miles of new railroad track were laid in the State. Ohio has now over 10,000 miles of railroad. In 1887 there were reported to the State Board of Railroad Equalization 7365.65 miles of main track and 1968.06 miles of sidings, which were valued for taxation at \$93,869,782.

Several trunk-lines cross the State from east to west and now have branches extending into nearly all parts of the State.

There are also several roads traversing the State from north to south, and these, with the shorter tributary roads constructed and under process of construction, enable Ohio people and the products of

Ohio farms and factories to readily reach all the cities of the country, the seaboard, and the markets of the world by almost direct routes. New lines are constantly being projected. The sworn reports of railroad officials to the railroad commissioner for 1887 show that for the year the gross passenger earnings of roads, all or part of which are in Ohio, were \$25,495,598.31; gross freight earnings, \$78,889,473.27; total gross earnings, \$112,546,743.19. The proportion of these gross earnings for the part of the lines in Ohio was \$56,785,652.86, an increase of 12.93 per cent. over the preceding year. The net earnings for the entire lines were \$37,270,852.90, the proportion of net earnings for Ohio being \$18,795,072.94, this being an increase of 30.69 per cent. over the preceding year for the portion of the lines in Ohio. The interest on bonds, etc., was \$15,188,403.38; dividends, \$6,481,398.19, and the rentals about \$3,000,000. The paid-in capital stock of the lines was over \$500,000,000, of which \$45,000,000 was held by 16,500 residents of Ohio. The bonded debt of the roads was over \$400,000,000, the proportion for Ohio being \$221,000,000. The unfunded debt was \$51,000,000, the proportion for Ohio being \$25,000,000. The number of passengers carried in 1887 was nearly 35,000,000, and the number of tons of freight hauled was over 85,000,000. The average freight rate per ton per mile in Ohio in 1886 was .658; in 1887, .707. The average passenger rate per mile in Ohio in 1887 was 2.179 cents. The law of Ohio makes three cents per mile per passenger the maximum passenger rate and five cents per ton per mile the maximum freight rate for distances over thirty miles. The proportion of accidents to persons travelling on railroads in Ohio, in 1887, was one passenger killed to 106,767 carried, and one passenger injured to 42,813 carried. An idea of the products of the State, as well as the business of the railroads, can be gained from the following classified freight tonnage carried by railroads in Ohio in 1887:

Freight Tonnage (Classified).

	Tons.
Agricultural products, etc.....	3,393,739
Coal.....	27,771,677
Flour.....	1,856,744
Grain.....	9,242,207
Ores.....	5,176,201
Pig and bloom iron.....	3,183,770
Iron, steel, and castings.....	4,272,878
Manufactures.....	5,737,985
Stone, lime, brick, tile, and sand.....	4,594,278
Live-stock.....	2,614,452
Lumber, timber, shingles, lath, and other forest products.....	6,854,247
Petroleum—crude and refined.....	1,287,325
Salt.....	265,785
Bran and mill feed.....	497,855
Merchandise.....	4,824,342
Miscellaneous.....	3,703,977
Total tonnage yielding revenue.....	85,277,462

[It should, perhaps, be explained that in giving the amount of earnings and other statistics for roads in Ohio the whole amount for the whole line of roads crossing or entering the State is given, as separate accounts are not kept for these roads for the portion of the line in the State. The proportion for Ohio in each case is, however, estimated and stated in the above statistics.]

Government and Administration.—The legislative power is vested in the General Assembly, consisting of a Senate and House of Representatives, the members of which are elected biennially. The judiciary department consists of a Supreme Court, consisting of five judges elected for five years each, Circuit Courts, Common Pleas Courts, Probate Courts, Police Courts, and Justices of the Peace. The Circuit Courts were established by a constitutional amendment adopted in 1885. There are eight circuits in the State, each of which

has three judges elected by the voters residing within the circuit. The supreme executive power is vested in the governor, who is commander-in-chief of the militia and at the head of the civil government. He is elected biennially and paid a salary of \$8000 a year. The lieutenant-governor, who is president of the Senate, with an annual salary of \$800; a secretary of state, annual salary \$2000, with \$1000 additional as fees; a State treasurer, annual salary \$2000, and attorney-general, annual salary \$1500, with \$500 additional as fees, are also elected biennially. The auditor of state, with an annual salary of \$3000, is elected for four years. Three members of the board of public works, each elected for a three-year term at a salary of \$800, and expenses, have charge of the public works. A State commissioner of common schools, with a salary of \$2000, is elected triennially; a clerk of the Supreme Court, with a salary of \$1500, and \$500 additional as fees, is also elected triennially. These with the five supreme judges are all the elective State officers. There are appointed by the governor, with the advice and consent of the Senate, a commissioner of railroads and telegraphs for two years; a State librarian for two years; a superintendent of insurance for three years; an inspector of mines for four years, and an inspector of shops and factories for four years; a commissioner of statistics of labor for two years; a supervisor of public printing for two years; a State inspector of oils for two years; three commissioners of fisheries for three years; a swamp land commissioner for an indefinite term; a dairy and food inspector; an inspector of leaf tobacco, and a number of minor officials in the executive department.

There is a State board of health, members of which are appointed by the governor. This board has general supervision of local boards of health, compiles vital statistics and adopts measures to prevent the spread of infectious diseases. There is also a State board of pharmacy consisting of five members, which was created in 1884. No person can compound prescriptions or keep a drug-store without first having been given a certificate by this board. All the pharmacists and assistant pharmacists in the State are registered. The duty of the board of pharmacy, in addition to examining applicants for certificates, is to prosecute all cases of violations of the law, which prohibits unauthorized persons dealing in drugs and medicines.

The governor also appoints a board of pardons of four members, two from each of the two leading political parties, and a State board of charities, consisting of eight members, four from each of the leading political parties, who investigate the system of public charities and the penal institutions of the State. The governor also appoints non-partisan boards of election of four members for each of the larger cities, to regulate the registration of voters and all elections held in these cities and appoint judges and clerks of election. Judges of all the courts, including justices of the peace and police judges in the larger cities, are elected by the people, as are also all clerks of courts. All county officers are elected by the people. The State is divided into two districts, a northern and a southern, in each of which is a United States court, district judge, clerk, and marshal. All elections are by ballot and every sane male citizen twenty-one years old and a resident of the State for one year next preceding the election may vote. Institutions for the care of the insane, deaf and dumb, imbecile, blind, veteran soldiers and sailors of the late war, and soldiers' and sailors' orphans, are maintained and supported by the State. The State penitentiary is located at Columbus, the capital of the State, and provision is made in it for the imprisonment of from 1500 to 2000 convicts. The death-penalty for murder is carried into effect within the walls of the penitentiary—condemned murderers, after being sentenced by the courts in the counties where the crime is committed, being removed to the penitentiary for execu-

tion. An intermediate penitentiary for the imprisonment of first offenders is being built at Mansfield.

Ohio is represented in Congress by two senators and twenty-one representatives. The county officers in each county are three commissioners, who have charge of the county property, fix county taxes, regulate roads, and have general supervision of all county matters. Three infirmity directors, an auditor, a recorder, a surveyor, a clerk of the Court of Common Pleas, who is also clerk of the Circuit Court, a treasurer, a sheriff, a coroner, and a prosecuting attorney, are all elected for three years except the treasurer, sheriff, coroner, and prosecuting attorney, who are each elected for two years. A county which contains a city of over 180,000 population has a board of control of five members, each elected for three years, which has final action and jurisdiction in all matters involving expenditures of money. Each county must contain at least 400 square miles of territory and the Legislature has power to lay out new counties. Counties are subdivided into townships, each of which must contain at least 22 square miles. County commissioners have power to lay out new townships. Township officers are three trustees, a clerk, a treasurer, constables, and an assessor. Township trustees have the oversight of elections in the county precincts, provide for the repairing of roads, afford relief to the poor, and have general charge of all township matters.

Education.—The receipts for school purposes in 1887 were \$1,761,725.46. The number of pupils enrolled in the common schools of the State were 767,030. The total number of youth of school age in the State were 1,102,721. The amount paid to the 88 counties for school purposes from the State treasury was \$1,707,104.90. The total expenses of the common schools for 1887, as reported by the school commissioner, were \$9,909,813.12.

Among the higher educational institutions of Ohio there has been progress and development in the past few years. One of them, Western Reserve College, formerly located at Hudson, has been removed to Cleveland, and its name changed to the Western Reserve University. With a large endowment and new buildings on Euclid avenue, the former town college has become a university, with a number of different departments. Strictly speaking, what was formerly Western Reserve College is now Adelbert College of the Western Reserve University, with which is joined the Case School of applied science. A female college is projected as part of the same, the system of co-education in Adelbert College having been dropped in 1888.

Finance.—The receipts of the Ohio treasury for 1887 were \$6,512,089.77; the disbursements were \$6,289,811.04; the funded State debt on Nov. 15, 1887, amounted to \$3,341,665, bearing interest at 3 and 4 per cent.

The value of realty in Ohio for 1887 was \$1,185,010,625; of personal property, \$520,172,094. The State taxes amounted to \$4,942,447.23; the total taxes, State, county, township, and municipal, were \$34,565,285.89.

The irreducible State debt (trust funds) was \$4,526,716.65, making the total State debt \$7,943,181.65. The debts of counties amounted to \$6,892,745.26; of cities of the first and second class, \$43,193,963.34; of incorporated villages, \$1,743,772.98; of townships, \$557,883.71; of special school districts, \$2,455,330.71, making the total local debts \$51,843,696. While the State debt is steadily decreasing and has been refunded at low rates of interest, the local indebtedness is increasing at the rate of about a million dollars a year, this resulting from local improvements, payment for which is made by the issuance of bonds by authority of the Legislature. Under the laws of Ohio, counties and cities can create local bonded indebtedness by securing permission from the Legislature.

(J. M. D.)

OILS. The oils known to commerce may be grouped under three general heads: animal and fish oils, vegetable oils, and essential oils. The first group, at one time by far the more important, has suffered in commercial importance by the inroads made in their use by the products of petroleum, the more important of the animal and fish oils before the advent of petroleum being the principal reliances for lubrication and illumination. The second group has been little affected by the discovery of petroleum, but oils that were only a few years ago unknown have come to the front, the most prominent example being cottonseed oil, now the most important of the seed oils. The list of distinctively American essential oils is a short one, although it contains one vying in importance with some of the more prominent essential oils of the old world—oil of peppermint. The oils manufactured in the United States are considered by groups as above.

ANIMAL AND FISH OILS.

Cod and Cod-Liver Oils.—The oil from livers of codfish is mostly imported from Newfoundland and from Norway. The amount manufactured by the fishermen is insignificant, and rarely enters the market in competition with the imported oils. The oil commercially known as cod oil is expressed from the heads, livers, and other waste portions of the fish. It is not a medicinal oil, but is used by curriers, and commands a ready sale at about one-half the price realized for the oils made from cod livers only. The annual production varies greatly, but may be said to average from 20,000 to 25,000 barrels.

Lard Oil.—The manufacture of lard oil in the United States has suffered less by reason of the substitution of the products of petroleum than have the whale- or sperm-oil industries. It is still used as a lubricant and burning oil where absolute safety is demanded, and is largely employed in compounding lubricating oils. Chicago is the centre of the lard-oil industry.

Menhaden Oil.—The menhaden-oil industry is of comparatively recent origin, having its beginning in 1850. In that year Mrs. John Bartlett, of Blue Hill, Me., while boiling some fish for her chickens noticed considerable oil on the surface of the water, which she collected in bottles and carried to an oil-merchant in Boston, Mass., who at once pronounced the oil valuable. The Bartlett family being encouraged to produce the oil in quantity, in 1851 sent to market 13 barrels of the oil from the "bony fish," or "mossbunkers," as the fish are popularly called in different sections along the New England coast. The first to sell the oil was Mr. E. B. Phillips, an oil-merchant of Boston. The mode of extracting the oil was most primitive, the fish being simply placed in large kettles with water, allowed to boil, and the oil skimmed off as it collected on the surface. From this small beginning the business grew rapidly, reaching its highest development in the year 1882. In this year the amount of capital employed in the business of catching the fish and rendering the oil was \$2,858,500. The number of factories in operation and firms engaged in the business was 97; there were 83 steam- and 212 sailing-vessels employed in taking the fish, while employment was furnished 2313 men. The number of fish caught was 346,638,500, and the amount of oil produced 2,021,312 gallons. From this year dates the decadence of the industry, although during the season of 1884, which begins in April and ends in October, the number of fish caught reached the enormous total of 858,592,700, and the amount of oil produced 3,722,927 gallons. In that year the number of factories in operation was 52, the number of steam-vessels engaged 59, and 157 sailing-vessels. Since then the decline of the industry has been more rapid, the statistics for 1887 being: amount of capital invested, \$1,000,000; number of factories in operation, 28; steam-vessels, 46; sailing-vessels, 38;

men employed, 1233; fish caught, 333,564,800; oil produced, 2,273,566 gallons. The decadence of the industry is due to the use of cheaper substitutes, principally products of petroleum. The principal use made of the oil is by tanners. It is also used in the safety-lamps of miners and to a limited extent in mixed paints. The fish appear in large schools along the coast, the southern limit of their appearance being off the coast of Virginia and their northern limit the coast of Maine, although during the past six years very few fish have been taken north of Cape Cod. The favorite resort of the menhaden is from Narragansett Bay along Long Island Sound, south to the Delaware capes. The oil made from the fish taken in these waters is superior to that made from fish taken farther south.

Neatsfoot Oil.—It is claimed that no perfect substitute for this oil has been found, and the use, although limited, shows little variation. It is largely adulterated, and has suffered in repute in consequence.

Porpoise Oil.—This oil is esteemed for lubricating fine machinery, but the demand therefor is limited. The oil is made at New Bedford, which is the only market where supplies are kept on hand. Vessels have been fitted out for the purpose of catching the porpoise along the coasts of New Jersey, Long Island, and the New England States, but the venture proved unprofitable.

Seal Oil.—The manufacture of seal oil is limited, and the demand therefor being small, there is an uncertain supply. Very little of the oil sold under the name is genuine seal oil.

Sperm and Whale Oils.—The introduction of the products of petroleum for all the uses for which sperm and whale oils were in former years exclusively employed has greatly diminished the use of these oils. The whale-oil industry from being one of the most important has dwindled to insignificant proportions. Since 1860 the decline of the industry has been steady and rapid. In that year the catch of sperm whales produced 73,708 barrels of oil, and of right whales 140,005 barrels of whale oil. The number of vessels engaged in taking the whale was 589, with an aggregate tonnage of 176,842 tons. In 1887 the amount of sperm oil produced was 18,873 barrels, and of whale oil 34,171 barrels. The total number of vessels of all classes engaged in the fishery was 116, having an aggregate tonnage of 27,851 tons. The city of New Bedford, Mass., is still the most important whaling port. New London, Conn., from ranking second in importance is at the bottom of the list, while Stonington, Conn., at one time having a larger amount of tonnage engaged in the industry than does New Bedford at the present time, has abandoned the business entirely, as has also Mystic, Conn., once an important whaling port. San Francisco now ranks second, with a fleet of 21 vessels, with a total of 6480 tons.

Tallow Oil.—The use of tallow oil has decreased, and its production is restricted to the demand. Substitutes of lower cost have supplanted this oil for nearly all purposes for which it was formerly exclusively employed.

VEGETABLE OILS.

Castor Oil.—This oil was formerly imported from Calcutta and London, but since 1875 the production in the United States has, except in years of small crop of seed, been sufficient to meet all demands. There are, however, importations each year from Calcutta, which tend to keep the price of the domestic oil from advancing beyond a certain limit. Five manufacturing firms produce nearly all the oil used in this country, and these working in harmony control the price. Improved methods of expressing the oil have been adopted, by which the yield is fully 30 per cent. of oil, whereas formerly 25 per cent. was regarded a good yield. Two qualities are made, although there is very little demand except for the best, other oils being preferred for lubricating purposes.

Corn or Maize Oil.—The manufacture of corn oil is of very recent origin, and is a distinctive American industry. In the manufacture of starch it is found desirable to get rid of the germ of the corn, and this was formerly a by-product for which no profitable use could be found, the germs being too rich in oil as a food for cattle, nearly or quite all the oil being in the germ. The germs as collected from the factories are first purified by separating them from the bran or husk of corn that adheres to them, and are then steamed under pressure to soften them, after which by means of hydraulic presses the oil is expressed, leaving as a residue an oil-cake, which, when ground into meal, is a valuable feed for stock, equal to corn-meal made from the whole corn. The color of the freshly made oil is a pale yellowish-brown, and its odor and taste that of freshly ground corn-meal. It does not readily become rancid by exposure to air, and in this respect compares favorably with the best olive oils. The unrefined oil has a specific gravity of 0.916 and 0.917 at 15° C., which is about that of pure olive oil. It saponifies rapidly with caustic alkalis, forming a white soap, and for the manufacture of the finer qualities of toilet-soaps it is found to equal the best olive oil. The supply can be increased to meet any demand likely to arise, and the price is about the same as the current market price of cottonseed oil. An analysis made by an eminent English chemist gave:

Fatty acids (free).....	0.88
Total fatty acids.....	96.70
Unsaponifiable, mucilaginous, and albuminous bodies.....	1.34

Cottonseed Oil.—See COTTON, chap. v.

Linseed or Flaxseed Oil.—Although many substitutes have been tried, linseed oil remains the most satisfactory in the mixing of paints and for the manufacture of varnishes and oil-cloths. The consumption in the United States is fully 25,000,000 gallons per annum, and the average increase is about 10 per cent. The number of mills in operation is 65, fully four-fifths being located in the Western States, with Chicago as the centre of the industry. The capacity of the mills is over 40,000,000 gallons, and owing to over-production the business has not been so profitable as formerly. Domestic seed is exclusively used at the Western mills, while the Eastern mills, notably those located in the city of New York and vicinity, use Calcutta seed when the domestic seed ranges high in price.

Mustard Oil.—Of the two oils contained in mustard seeds the volatile oil is not produced on a commercial scale in the United States, nor is it much used, other rubefacients being preferred. The expressed fixed oil has a moderate sale, being used as an adulterant in salad oils, although the oil expressed from cottonseed has of late years supplanted mustard oil for this purpose. The quantity produced in this country is not important.

Peanut Oil.—Peanuts contain more than 20 per cent. of a fixed oil which was formerly an important article of commerce, but the low price of cottonseed oil has made the expression of ground-nut oil unprofitable, the nuts being of greater market value as an article of food. The oil has a bright yellow color and a mild taste, with the characteristic odor of the fruit. Its specific gravity is 0.918 at 15.5° C. It is a non-drying oil unsuited for paints, but is a good burning oil, equal to the best sperm oil.

ESSENTIAL OILS.

Peppermint Oil.—The herb from which the oil of peppermint is distilled (*mentha piperita*) is grown in Wayne co., N. Y., and in sections of the State of Michigan. The herb is distilled by the growers in primitive stills and sold to dealers, although some sell the herbs to those who make a business of distilling

the oil in improved apparatus. The oil is variable in quality and the yield of the herb uncertain, in some years proving unprofitable. The value of the exports of this oil exceeds that of all the other essential oils produced in the United States. The principal market for this oil is New York.

Sassafras Oil is the least important of the essential oils that may be called American, both as to the value of the oil and the quantity produced. Maryland, Virginia, Delaware, and West Virginia are the principal sources of supply. As this is the cheapest of the essential oils it is largely used in the arts, and was the most common scent for soap until supplanted by myrrhane oil. As distilled from the fresh roots the yield is about 2 per cent. The dried bark is said to yield 5 per cent. of oil.

Wintergreen Oil.—The oil known in commerce as wintergreen oil is not made from the plant of that name, although such was the case in former years. It is a product of the distillation of the bark of the sweet birch, which is more abundant and richer in oil. The properties of the oil from both sources are identical. The principal sources of supply are the States of New Jersey, New York, and Pennsylvania, where it is distilled in a primitive manner and sent to market or sold to dealers who collect it. The supply is always equal to the demand. (U. S. G. A.)

OJIBWAYS, or CHIPPEWAS, a tribe of American Indians of the Algonkin stock, have been known since 1640, when the French first explored the western shores of Lake Huron. A mission was founded at the Sault Ste. Marie by the Jesuit Fathers Jogues and Raymbault in 1642, and hence the Ojibways have become known in Canada as the Sautaux. They are hardy, strong, and devoted to war and hunting. They drove the Sioux beyond the Mississippi, and during the French domination they rendered effective assistance in raids on the British settlements. They joined in the conspiracy of Pontiac and surprised the fort at Mackinaw in 1763. Brought under British influence they threatened the American border settlements during the revolutionary war, and at its close gave much trouble in Ohio. They were defeated by Gen. Wayne and made a treaty at Greenville, Aug. 3, 1795. They were then scattered along the southern shores of the Great Lakes, from Erie to the head waters of the Mississippi. In the war of 1812 they joined Tecumseh in aiding the British, but in 1816 they again made a treaty of peace, and soon after abandoned their lands in Ohio. They were then reckoned at 14,000, and in 1825 the limits of their territory were defined by treaty, but these have since been greatly reduced.

The Ojibways who remained in the reservations in Upper Michigan and Wisconsin became peaceful and industrious and responded well to missionary efforts. Besides the Roman Catholic missions, which are still maintained to some extent, the Episcopalians, Presbyterians, and Methodists have shared in this work. In 1887 there were reported 4012 Chippewas in Wisconsin, who were doing moderately well at farming and logging. Those in Michigan had given up tribal relations, many of them exercise the right of suffrage, and they are sometime elected to local offices. Those not on reservations are exposed to frauds from the whites, and the education of their children is neglected. Those Ojibways who removed to Minnesota long retained their old habits and many have become degraded under the influence of vicious whites. In 1887 there were reported at Turtle Mountain agency, Dakota, 1126 persons, of whom 309 were full-blood Chippewas, the rest of mixed blood. They are Catholics and are dependent on the government for support. This reservation contained 16,080 acres, divided into timber, farming, and grazing lands. Beyond its limits there were many others living among the whites and on equal terms. To the labors of the missionaries is due our knowledge of the language and customs of the Ojibways or Chippewas. H. R. Schoolcraft did much

to popularize it. Two members of the tribe have published histories of the Ojibways, George Copway (Boston, 1851) and Peter Jones (London, 1861).

OKRA (*Hibiscus esculentus*) is a species of the *Malvaceæ* or Mallow family, mucilaginous plants which are found throughout the tropical and temperate parts of the earth. The okra, in the opinion of some, is a native of the East Indies, though De Candolle thinks that its name points to an origin in tropical America. It is an annual, generally resembling the mallows, with a stem 2 to 6 ft. high, and rigid, 5-lobed leaves, in whose axils grow large, yellowish flowers with purplish centres. The fruit is a narrow, 10-angled pod, 4 to 8 inches long, of pyramidal shape, with pointed extremity. It contains numerous kidney-shaped seeds.



The plant is cultivated for its pods, which when young contain mucilage in abundance. They are gathered while still tender, and before any woody fibre appears, and are used as a thickening material for the peculiar Southern soup called gumbo. They are also sometimes boiled and dressed like asparagus. The pods are salted for winter use, or sliced and dried. The inner bark of the okra yields an excellent fibre, and has been proposed as suitable for paper stock.

OLAF, SAINT (c. 995–1030), king and patron saint of Norway, was a son of Harold Gränske, and grandson of Harold the Fair-haired. When only 12 years old he led a Viking fleet to the coasts of Britain, and afterwards plundered the coasts of Sweden, France, and Spain. Having become one of the most dreaded sea-kings, he returned to Norway in 1014, and made himself master of the kingdom, and introduced Christianity. He burned the heathen temples and used such violence that a rebellion was excited. In 1028 Canute came with an army to enforce his claim to Norway and Olaf fled to Russia. After two years he returned with aid from Sweden, and was defeated and killed near Drontheim, July 29, 1030. When Christianity was fully established his body was enshrined in the Cathedral of Drontheim, and Olaf was made the patron saint of the country. In 1847 King Oscar I. instituted the order of St. Olaf.

OLEOMARGARINE. The making of artificial butter has become of late years an industry of such importance that some account of its origin and growth is here requisite. It originated in the desire

of the French government to provide the poorer classes with a cheap substitute for butter. They employed M. Mège-Mouriès to make experiments with this object in view. Presuming that beef fat might contain the constituents of butter, he experimented with suet, which he found to be below butter in its proportion of oleine. By extracting a portion of palmitine and stearine from the fat, he brought its proportion of oleine up to that of butter, and by proper manipulation produced a substance not easily distinguishable from butter, while much cheaper. This substance he named oleomargarine, under the idea that butter contains margarine. This is a mistaken idea, and the name is not properly applicable. Butterine, which is frequently used, is a more correct title.

It is needless to describe M. Mège's method of manufacture, as an improved method is now adopted in

the American factories, in which large quantities of butterine are annually made. Briefly to outline the process, the beef fat is first thrown into tanks of tepid water. This is repeated three times, such of the fat as does not seem suitable being withdrawn after the first washing. All impurities having been thus removed, only pure white fat remains. This fat is minced in a cutting machine and melted by the use of live steam, the temperature being kept carefully between 114° and 122° F., and about 5 per cent. of salt being added. The membrane sinks to the bottom of the kettles, and the pure floating fat is drawn off. After some other purifying processes the fat is allowed to solidify very slowly. It is then exposed to a pressure of 3000 lbs. to the square inch, in order to separate the butter oil from the stearine. This is kept up until the butter oil, or oleomargarine, ceases to flow, the stearine residue remaining as a hard, white, dry mass. Much of the oil is exported to Europe in this way, there to be churned with milk into artificial butter. If properly sealed up, it will keep an indefinite period. It is of a light yellow color and an agreeable taste, melting in the mouth like butter. When churned it is mixed in the proportion of 442 parts oleomargarine, 120 parts milk, 37½ of butter, and 1½ oz. bicarbonate of soda. This is churned from 5 to 10 minutes, some coloring matter added, and then churned from 30 to 40 minutes longer. The substance produced resembles butter in taste and appearance, though it has a tendency to crystallize, and become lumpy. This is avoided by chilling it during the process of hardening.

Pure oleomargarine butter is said to contain every element that enters into cream butter, and to keep pure much longer. But there is the defect of not knowing when it is pure, or what injurious ingredients or objectionable processes may be used in its manufacture by irresponsible parties. It is, however, manufactured in large quantities in America, partly for home use, but more largely for shipment to Europe. Three factories in the State of New York produce not less than 4500 tons yearly, while similar factories exist in nearly all of our large cities. In some of these factories lard is mixed with oleomargarine, yielding compounds known as lardine, suine, and lard cheese. In 1880 the statistics of the oleomargarine manufacture were as follows:

Establishments.....	15
Capital invested.....	\$1,680,000
Value of material.....	5,486,141
Value of product.....	6,892,939

The factories were situated principally in New York, Kentucky, Ohio, Illinois, and Pennsylvania. Since that date their product has largely increased.

Recent reports from Holland state that the exports of oleomargarine from the United States are steadily increasing, and were much larger in 1887 than in former years, and that all measures taken to suppress the manufacture of artificial butter serve only to make it better known and more popular, and to increase its consumption. The law in Germany against it, for instance, has been followed by an extension of the butter factories, while the new law against butterine in England, which took effect Jan. 1, 1888, promises to have a similar effect. The exports of American butterine, in 1887 to the two ports of Rotterdam and Amsterdam were 184,600 tierces, containing about 60,000,000 lbs. This was one-third more than the 1886 export. Holland imported as much in 1887 from European factories, while making much in her own factories. The making of artificial butter, indeed, is now the largest manufacturing interest of the Netherlands. The annual consumption in Paris at present is from 60,000 to 80,000 lbs. daily.

In view of the extensive and growing sale of this substance in the United States as cream butter, restrictive laws have been passed by several of the States, and the

better to prevent fraudulent sales Congress has recently passed a stringent law taxing the manufacture and sale, and requiring under penalty that every package containing artificial butter shall be duly marked with the name of its contents, and that retail dealers shall not sell except from the original packages. The law lays on manufacturers a tax of \$600, on wholesale dealers of \$480, and on retail dealers of \$48, with an additional tax of 2 cents on every pound sold. This law has gone far to restrict the fraudulent sale. Sold for what it is, oleomargarine is not likely to interfere greatly with the dairy business of this country, as it will be used mainly for cooking purposes. Its use as table butter is likely to be mainly confined to the poorer classes of Europe.

We append a comparative analysis of natural and artificial butter, which shows that when properly made the latter is a wholesome and satisfactory substitute for the former.

	Fat.	Caseine.	Ash.	Water.
Good market butter.....	86.06	0.42	0.12	13.77
Poor ".....	82.60	0.72	0.20	17.18
Artificial butter, Mège's process.....	86.24	1.20	12.56
Artificial butter, American process.....	87.15	0.57	1.63	11.50
Frankfort Margarine Co.....	87.97	0.26	0.17	11.42

(C. M.)

OLIN, STEPHEN (1797-1851), preacher and educator, was born at Leicester, Vt., Mar. 3, 1797. He was the oldest son of Judge Henry Olin (1757-1837), who was lieutenant-governor of Vermont 1827-29. He graduated at Middlebury College in 1820, and became principal of an academy in South Carolina. In 1824 he entered the South Carolina Conference of the Methodist Episcopal Church. In 1826 he was made professor of English literature in the University of Georgia, and in 1834 became president of the Randolph-Macon College, Virginia. He went to Europe in 1837 and made an extensive tour in the East, which is described in his *Travels in Egypt, Petra and the Holy Land* (1843). Being made president of Wesleyan University in 1842, Dr. Olin exerted himself with great success to give this institution high rank among American colleges. He was at this time at the height of his power as a preacher, intellectual, fervent, and practical. In 1846 he was a delegate to the first meeting of the Evangelical Alliance in London. He died at Middletown, Conn., Aug. 16, 1851. His *Sermons* were published in 1852, and his *Life and Letters* in 1853.

OLIPHANT, LAURENCE, a roving Englishman whose travels and adventures have furnished material for several books, was born in 1829, being the only son of Sir Anthony Oliphant, who became chief-justice of Ceylon in 1838. In 1850 Laurence accompanied Jung Bahadoor, the Nepaulese ambassador to England, on his return to Katmandu, and published an account of the journey. After studying at the University of Edinburgh and being admitted to the English bar, he visited Southern Russia. His book on *The Russian Shores of the Black Sea* (1853) acquired special interest from the Crimean war which soon followed. Oliphant next became private secretary to Lord Elgin, Governor-General of Canada, and was made superintendent of Indian affairs. His travels in this capacity gave occasion for his book on *Minnesota, or the Far West* (1855). He travelled through the United States and even accompanied a filibustering expedition to Central America. Returning to England he published *The Trans-Caucasian Provinces* (1855) and then hastened to join the army of Omar Pacha in a campaign to that region. In 1857 he was again private secretary to Lord Elgin, then minister plenipotentiary to China, and subsequently published an account of this mission. In 1861, while he was acting as *chargé d'affaires* in Japan, a bold attempt was made on his life and he was severely wounded. In 1865 he was elected to Parlia-

ment from Sterling, but he resigned in 1868, and with his mother joined the religious community established by Thomas L. Harris (*q. v.*) at Portland, N. Y. In 1870 he returned to Europe and was for a while Paris correspondent of the *London Times*. In 1873 he became the agent of a trans-Atlantic telegraph company and resided in the United States. After a few years he went to Syria with a view to establishing a colony there. This project was only partly successful, but he made explorations of the country east of the Jordan, which are described in *The Land of Gilead* (1881). Besides the books of travel already mentioned his *Patriots and Filibusters* (1861), *Piccadilly* (1870), and *Travels and Travesties* (1882) contain records of his observations of men and events. He has also published a novel, *Altinea Peto* (1883), and *Haji* (1887), a description of contemporary life in Palestine, as seen in a second visit, connected with his colonizing project.

OLIPHANT, MARGARET WILSON, an English novelist of Scotch extraction, was born at Liverpool in 1818. Her first novel, *Passages in the Life of Mistress Margaret Maitland* (1849), was an attractive revelation of life in a Scotch parish. She continued to exhibit Scotch life and character in several stories, but afterwards gave equally excellent delineations of the life of English rural towns. The most noted of these is *Chronicles of Carlingford* (1863), which was continued in several volumes. All her stories are marked by a subdued yet earnest religious tone. In 1862 she published an interesting *Life of Edward Irving*, and she has also given to the world biographies of *St. Francis of Assisi* (1870) and *Count Montalembert* (1872). In *The Makers of Florence* (1876) she depicts Dante, Giotto, and Savonarola; and *The Makers of Venice* (1888) is a similar work. She has also contributed to the history of England in her *Historical Sketches of the Reign of George II.* (1869). Her *Literary History of England* (1882) is confined to the end of the eighteenth and beginning of the nineteenth century. Her *Life of Sheridan* (1883) in the series of "English Men of Letters" is a pleasing sketch. Her latest biography is that of Principal Tulloch, of whom she was a warm admirer.

OLIVER, ANDREW (1706-1774), lieutenant-governor of Massachusetts, was born at Boston, March 28, 1706. He graduated at Harvard College in 1724, and was a member of the General Court, and afterward was secretary of the province. In 1765, having accepted the office of distributor of stamps under the stamp-act, he was compelled to resign under the Liberty Tree, August 15. In 1771 he was appointed lieutenant-governor, and with his brother-in-law, Governor Hutchinson, secretly furthered the designs of the British ministry. The General Court, discovering this, petitioned the king for the removal of both. Lieutenant-Governor Oliver died at Boston, March 3, 1774. He was succeeded in office by his relative, THOMAS OLIVER (1734-1815), who was compelled by the people to resign Sept. 2, 1774, and afterwards went with the British troops to Halifax, and thence to England.

Andrew's brother, PETER OLIVER (1713-1791), born March 26, 1713, graduated at Harvard College in 1730. After holding several offices in Plymouth co., he was in 1756 made a judge of the Supreme Court, and in 1771 became chief-justice. In 1771, having refused the demand of the Assembly to engage to receive no pay except from that body, he was impeached. He afterwards accompanied the British troops when leaving Boston in 1776. He died at Birmingham, England, Oct. 13, 1791.

OLLIVIER, ÉMILE, a French statesman, was born at Marseilles, July 2, 1825. He was the son of Demosthène Ollivier, an ardent republican, studied law at Paris, and was admitted to the bar in 1847. When the Republic was established in 1848 he was made commissary-general at Marseilles, but soon returned to his profession. After the *coup d'état* of December, 1851,

his father was driven from France, but Émile, prudently avoiding politics, acquired high reputation as an advocate. In 1857 he was elected to the Chamber of Deputies, where he became a leader of the opposition. But his hostility to the emperor gradually abated and finally, in 1867, he was entirely won over. In December, 1869, he was called by the emperor to form a cabinet and draft a constitution. This plan was approved by the plébiscite, May 8, 1870, but the declaration of war against Germany and its disastrous results overthrew first his cabinet and then the Empire. Ollivier retired to Piedmont, but towards the end of 1872 returned to his home at Passy. In 1870 he had been elected to the academy on account of his official position, but when he now attempted to take his seat in 1874 his inaugural address caused disturbance by its defence of the Empire. On other occasions disputes arose and finally, in May, 1879, he withdrew from the academy. In early life he assisted in founding and conducting a law magazine. He afterwards published various political essays. His latest works are *L'Église et l'État au Concile du Vatican* (2 vols., 1879), and *M. Thiers à l'Académie et dans l'Histoire* (1880).

OLMSTED, FREDERICK LAW, an American landscape gardener, was born at Hartford, Conn., Nov. 10, 1822. He studied engineering and natural science at Yale College, and became a farmer. In 1848 he began to manage a fruit-farm on Staten Island. In 1850 he made a tour in England which he narrated in his *Walks and Talks of an American Farmer in England* (1852). On his return he made a journey on horseback through the Southern States, as correspondent of the *New York Times*. His letters drew attention to the deplorable effects of slavery on agriculture. They were collected in his volumes, *A Journey in the Seaboard Slave States* (1856); *A Journey through Texas* (1857); *A Journey in the Back Country* (1860); and a general summary was given in *The Cotton Kingdom* (1861). In 1855 he had made a tour on the Continent of Europe to examine the parks, and when in 1856 plans for laying out Central Park, in New York, were called for, that offered by Mr. Olmsted and Calvert Vaux was adopted. Mr. Olmsted was appointed architect and chief engineer, and carried out his plans energetically until the outbreak of the civil war. He then became secretary of the U. S. Sanitary Commission. After the war he was again made architect-in-chief of the Central Park, and was also engaged in laying out parks in Brooklyn, Washington, and Chicago. In 1878 he was removed from office by a new board of commissioners, but he has conducted his labors with much success in parks for other cities. His firm has had charge of the Niagara Reservation Park.

OLSHAUSEN, HERMANN (1796-1839), a German theologian, was born at Oldesloe, Holstein, Aug. 21, 1796. He was educated at Kiel and Berlin, and in 1821 was made professor extraordinary of theology at Königsberg, becoming full professor in 1827. He accepted a call to Erlangen in 1834, and died there Sept. 4, 1839. His chief work is a *Biblical Commentary on the New Testament* (4 vols., 1830-40). It was completed by Profs. Ebrard and Wiesinger (vols. 5-7, 1850-53). Prof. A. C. Kendrick revised the American edition (6 vols., 1856-58).

His brother, JULIUS OLSHAUSEN (1800-1882), a distinguished Orientalist, was born May 9, 1800, and educated at Kiel, Berlin, and Paris. In 1823 he was made extraordinary professor at Kiel, and in 1830 became full professor. In 1848 the provisional government of Holstein entrusted to him the superintendence of the university. He also represented the city of Kiel in the parliament, of which he was made vice-president. In 1852 the Danish government came into possession of the country, and Olshausen was deprived of his office. In 1853 he was made librarian and professor of Oriental languages at Königsberg. In 1858 he was made councillor in the Prussian ministry of education. In 1874 he retired on a pension, and he

died at Berlin, Dec. 28, 1882. His Oriental researches related chiefly to the languages and antiquities of Persia, and to the Old Testament. Among his publications were *Erklärung der Psalmen* (1853); *Lehrbuch der Hebräischen Sprache* (1861); *Die Pehlewi-Legenden auf den Münzen der letzten Sassaniden* (1843). His latest investigations appeared in the publications of the Berlin Academy. See PAHLAVI in the ENCYCLOPEDIA BRITANNICA.

Another brother, THEODOR OLSHAUSEN (1802-1869), was an active politician and journalist at Kiel. In 1848 he took part in the provisional government, but he afterwards joined the democratic opposition. In 1849 he founded the *Norddeutsche Freie Presse*, at Hamburg. In 1851 he came to America, and edited a paper at St. Louis. Several German works on the Western States of America, prepared by him, were published at Kiel. In 1865 he returned to Europe and died at Hamburg, March 31, 1869.

OMAHA, the largest city of Nebraska, is on the west bank of the Missouri River, 600 miles above its confluence with the Mississippi. It is an important railroad centre, having several lines to Chicago, St. Louis, Texas, and California. A belt-line railroad encircles the city, accommodating local trade and enabling the trunk lines to reach the business centre. There are over 20 miles of street railroad track. The streets are 100 ft. wide, and in the business part are paved with asphalt or stone. Three squares are reserved for parks. Large and costly buildings line the principal streets. Among them are a fine city-hall, court-house, U. S. government building, Joslyn and other hotels, Boyd's opera-house, the national banks, and various buildings for business purposes. The Chamber of Commerce, organized in 1885, has a handsome and commodious building. In 1886 the Omaha Exposition building was completed; its main hall seats 6000 persons. The wholesale business of the city, which exceeds \$75,000,000, is conducted by 250 firms and there are over 2000 retail firms. The prosperity of Omaha is due to the railroads; though it was founded in 1854, the first railroad from Chicago entered the city in January, 1867. The Union Pacific was completed May 10, 1869, and at once gave a great impetus to the city. Previously the Missouri was here crossed in winter on a pile bridge, which was removed during the season of navigation. Soon an iron bridge, 2750 ft. long, was built at a cost of \$2,500,000, and it has since been enlarged at a further expense of \$1,000,000. Omaha has 60 churches, 25 school-buildings, a high-school, Creighton College, Brownell Hall for young ladies, a Catholic academy, a medical college, and a business college. The industrial works comprise large smelting- and refining-works, car-shops, and various factories. The city is lighted with gas and electric light. The water supply is drawn from the Missouri, being filtered and allowed to settle in a reservoir. The daily consumption exceeds 8,000,000 gallons. Since 1884 there has been a city paid fire department, besides one belonging to the Union Pacific Railroad. There are 40 miles of sewerage; garbage is removed by boats which dump it in the middle of the river-channel. The city limits extend 8 miles along the river and 4 miles back. It is governed by a mayor and 12 councilmen, the mayor being chosen for two years. The annual expenses exceed \$1,000,000, yet the amount is raised with little difficulty. The bonded debt is \$857,950. In 1886 the school census showed 11,831 persons of school age, indicating a population of nearly 60,000, and this has continued to increase.

Near the city the U. S. government has a tract of 82½ acres for military purposes. It contains the headquarters of the Department of the Platte. In South Omaha are the extensive stockyards of the Union Pacific Railroad.

OMAHAS, a tribe of American Indians of the Dakota family (see DAKOTA INDIANS). They were known to the explorers of the Upper Mississippi as

peaceful and inclined to agriculture. They were harassed by the Sioux and other tribes. About 1800, being severely afflicted with small-pox, they burned their villages, and journeyed southward along the Missouri. Lewis and Clarke report their number as 600 in 1805. In 1815 the first treaty was made with them by the United States when they ceded Council Bluffs. The Sioux continued to persecute them, but after these enemies were repressed by the U. S. troops the Omahas improved greatly. Their reservation in Northern Nebraska comprised 375,000 acres. About 1883 an experiment was made in leaving them to take care of themselves. They have suffered somewhat, but appear to be learning self-reliance. They still have the benefit of Presbyterian missionaries and the mission and industrial boarding-schools were reported in 1887 as crowded. Besides these schools, many of the children are taught at Carlisle, Pa., Hampton, Va., and other places. The number of Omahas in 1887 was reported to be 1175.

OMAR PACHA (1806-1871), Turkish general, was born at Plaski, Croatia, in 1806. He was the son of an officer of the Austrian army and was originally named Mikail Lattas. While serving in 1833 in a regiment on the frontier he incurred disgrace and fled to Bosnia, where he professed the Moslem faith. Being made tutor of the sons of Hussein Pacha, he went to Constantinople, where he also taught Abd-ul-Medjid. In 1839 the latter became sultan and made his tutor colonel and afterwards brigadier-general. In 1842 he was military governor of Lebanon and soon became pacha. Called thence to subdue rebellions in Albania and Bosnia, he displayed remarkable energy. In the war with Russia in 1854 he was appointed generalissimo, and drove the Russian invaders out of the Danubian principalities. In 1855 he successfully defended Eupatoria and was sent to the relief of the besieged Kars, but arrived too late. After the war he was governor of Bagdad, but in 1859 was dismissed for maladministration and banished to Kharput. Restored to office in 1861, he was again employed in Bosnia. In March, 1867, he was sent to suppress the rebellion in Crete, but his cruelty occasioned his recall in October. Thenceforth he was one of the Sultan's council till his death, April 18, 1871.

ONCKEN, JOHANN GERHARD (1800-1884), a German evangelist, was born at Varel, in Oldenberg, Jan. 26, 1800. In his youth he visited England and there joined an Independent congregation. He was sent as a missionary to Germany by the British Continental Society in 1823. He afterwards became at Hamburg the agent of the Edinburgh Bible Society and was the first to establish a Sunday-school in his native land. In 1834 he adopted Baptist views and as the laws of the country were severely intolerant he was secretly baptized by Rev. Barnas Sears, who was then studying in Hamburg. Oncken became the pastor of the first Baptist church in Germany, founded in April, 1834. Soon after he was appointed a missionary of the American Baptist Convention. His religious work was conducted throughout Germany, Switzerland, and Denmark, by preaching, distributing the Scriptures, and forming congregations. In his fidelity to duty he braved the most serious opposition and on some occasions endured corporal chastisement. His labors were so incessant and his success was so marked that he became widely known as "the German Apostle." In prosecution of his work he visited the United States in 1852 and 1865. After a long and faithful life he died Jan. 2, 1884. He had published and edited many tracts and religious journals.

ONEIDAS. See IROQUOIS.

ONION. See AGRICULTURE, chap. v., 2.

ONONDAGAS. See IROQUOIS.

ONTARIO, LAKE, the smallest of the chain of great lakes which finally empty into the St. Lawrence River, has a length of 190 miles; maximum breadth, 55 miles; and maximum depth, 600 ft. So great is

the number of small bays and inlets that the circuit is over 500 miles. The principal harbors are Kingston, Coburg, Toronto, and Hamilton, in Canada; and Charlotte, Oswego, and Sackett's Harbor in New York. The commerce of the lake is very important, connection being made with the Erie Canal and the Hudson River through the Oswego Canal, and with the upper lakes through the Welland Canal, which connects Lake Ontario with Lake Erie, the entrance to the former lake being at Port Dalhousie. The level of Lake Ontario is 250 ft. above the ocean. Therefore the bottom of the lake, in some parts, is 350 ft. below the surface of the ocean. Ontario being much shallower than any other of the great lakes (with the exception of Erie), the bottoms of the upper lakes drop to about the same level as that of Ontario.

The discharge of water through the Detroit River from the lakes above, after allowing for the probable portion carried off by evaporation, does not appear by any means equal to the quantity of water which the three upper lakes receive. It has been conjectured that a subterranean river may run from Lake Ontario. This conjecture is not improbable, and, if correct, accounts for the singular fact that salmon and herring are caught in all the lakes communicating with the St. Lawrence, but in no others. As the Falls of Niagara block the way, it would seem that the fish reached the upper lakes by some underground river. The theory of an underground river has also been adopted by several scientists who have been watching the variations in the levels of the great lakes. There are two kinds of variations: the annual, which rise from the melting of the snows in the spring; and the occasional, which come at various intervals. All of the lakes west of the Niagara River are subjected to the occasional variations. The period of each rise and fall covers from 4 to 7 years. The variation from lowest to highest points has sometimes been as much as 3½ ft. These variations are aside from those caused by the winds. In September and October Lake Michigan is subject to an annual flood-tide, the ebb-tide occurring in January, February, and March. Lake Ontario is subject to such variations, but, apparently, in a less degree. The fact that certain of the variations have taken place at the time variations were noticed in the upper lakes tends to confirm the theory of the underground channel. In 1886 the superintendent of the U. S. Life-Saving Service, in which Lake Ontario is included, reported that the unusual high water all along the lake had become troublesome. At the same time there was high water in Lakes Erie and Michigan. On the other hand there have been periods when the level of Lake Ontario has fallen to such an extent that the towns along its banks became alarmed lest they should be left in the interior. One reason assigned was that Lake Erie had become so filled up by sand brought down from the Detroit River that it had become itself merely a river, thus keeping back the flow of water and allowing it to evaporate in the upper lakes. Another reason given was that the outlet of Ontario, the River St. Lawrence, had been so enlarged by the enlarging of a canal at "The Gallops" Rapids that more than twice the usual quantity of water had passed through. In other words, the removal of the natural dam of Lake Ontario had resulted in lowering the level of the lake. At the present time (1888), however, there appear to be no complaints in regard to the level. There are on record a number of instances where the level of the lake has risen suddenly by the appearance of a tidal wave. Such a wave caused the water to rise 22 in. at Charlotte (the port of Rochester) in 1872.

Ontario, being the lowest of the Great Lakes and surrounded by some of the largest mountain ranges in the country, forms an intensely interesting subject for scientific investigators. The geology and topography of the lake are so combined that they cannot readily be separated. The eastern end of the lake is confined

by the Laurentian rocks of the Adirondack Mountains of New York, and its outlet is over the low and narrow barrier of the same, forming the Thousand Islands. The lake itself is excavated out of the soft Lower Silurian rocks. The northern limit of the basin is an east and west line, about 50 miles back from the northern shore. Its southern limit is made by three remarkable escarpments, ranging in parallel east and west lines from the Hudson River to Lake Erie, caused by the broad outspread and almost imperceptible southern dip of the whole palæozoic system, from the Potsdam sandstone at the bottom of the Silurian to the coal-beds at the bottom of the Carboniferous rocks. The baset edges of the formations make a series of steps toward the north; while down the southern slope, almost from the very edge of the lakes of Central New York, flow all the northern waters of the Delaware, Susquehanna, and Ohio Rivers. The lowest escarpment is that of the Niagara, or Middle Silurian, formation which commences at a slight elevation between Albany and Utica, along the south side of the Mohawk Valley, and crosses the Niagara River at Lewiston. Back of this runs the escarpment of the Helderberg, or Lower Devonian, limestones, forming high hills south of the Mohawk, but dying away as it approaches Lake Erie. Still farther south, and at a still higher elevation, runs the high escarpment of the Upper Devonian sandstone, from the base of the Catskill Mountains, on the Hudson, to Lake Erie. The range runs along the southern shore of Lake Erie into South-western Ohio. At an elevation of 1000 ft. above Lake Erie are the bituminous coal-fields of Ohio and Pennsylvania, and from the northern part of these fields the River Genesee cuts its way through the three escarpments into Lake Ontario. In the western and central parts of the State of New York deep valleys have been cut between the middle and upper escarpments and into the Lower Devonian terrace. These are known as Lakes Canadaga, Cayuga, Seneca, Crooked Lake, Auburn, and Skaneateles—all of them, with Lake Oneida, at the foot of the lowest escarpment, drained by the Oswego River into Lake Ontario. But the principal drainage of Southern New York is southward through the upper escarpment and by deep gorges in the Allegheny Mountains of Pennsylvania, by the Susquehanna River and Chesapeake Bay, into the Atlantic Ocean. In Western New York the same set of the waters away from Lake Erie carries the drainage into the Allegheny, Beaver, and other affluents of the Ohio, the head waters of which, therefore, overlook Lake Erie 1000 feet from a distance of scarce a dozen miles. There are, in fact, several spots along the watershed where the head waters of the St. Lawrence, the Susquehanna, and the Allegheny may be fed by the same cloud. Lake Chautauqua, which drains into the Allegheny River, is much farther north and at a much higher elevation than the interior lakes of New York, named above, which drain into Lake Ontario. The lowest or Middle Silurian escarpment crosses the Niagara River and becomes the constant limit of the basin of Lake Ontario. At Lewiston Heights it is 365 ft. above the lake. Entering the Province of Ontario it turns about the head of the lake and runs to the Georgian Bay and then to Lake Huron at Cape Hurd. The Blue Mountains of Georgian Bay are of the Upper Silurian strata. This makes Lake Simcoe lie in a hollow of the Lower Silurian lakes similar to that which confines Lake Ontario, Lake Champlain, and the Gulf of St. Lawrence. Lakes Simcoe, Ontario, and Champlain, and the Gulf of St. Lawrence would form a continuation of the same water basin if it were not for the rise in the Lower Silurian rocks between Simcoe and Ontario and the upper of the Laurentian rocks at the Thousand Islands, below which are all the rapids of the St. Lawrence down to Montreal. It is, apparently, agreed by geologists that when the whole of this part of the continent was submerged 300 or 400 ft. below the

present surface of the ocean there was one island known now as the Adirondack Mountains of New York; and there was another island known now as the Green Mountains of Vermont and Western Massachusetts. In those days it is said that the northern shore of the Gulf of St. Lawrence extended as far as the Lac des Chats. In that case Lake Ontario was simply a hole in the bottom of a great inland sea which covered also the Falls of Niagara and probably rose above the present level of the Great Lakes which lie above the falls.

The topographical advantages of Lake Ontario have also given it a prominent place in American history. From the earliest settlement of the country this lake was a favorite route of transportation to the West. In the war of 1812 important conflicts were waged on the lake and the adjoining shores. (F. G. M.)

OOSTERZEE, JAN JAKOB VAN (1817-1882), a Dutch theologian, was born at Rotterdam, April 17, 1817. He was educated at the University of Utrecht, and was ordained in 1841. After a few years' service in village churches he was in 1844 called to the principal church in Rotterdam, where he was noted for his earnestness and eloquence. In 1862 he was made professor of theology in the University of Utrecht, but from 1867 his work was chiefly in New Testament introduction and the philosophy of religion. He was a voluminous writer and was justly regarded as the leader of Evangelical thought in Holland. In 1871 he declined a call to a professorship in the theological seminary of the Reformed Church in America at New Brunswick, N. J. The fortieth anniversary of his ordination was celebrated in May, 1881, when, although oppressed by physical weakness, he preached a sermon of great power, and afterwards received testimonials from his numerous pupils. He died July 29, 1882, at Wiesbaden, Germany, where he had gone for the benefit of his health. Among his publications were a *Life of Jesus* (3 vols., 1847-51); *Christology* (3 vols., 1855-61); *Theology of the New Testament* (1867); *Christian Dogmatics* (1872); *Fear of Salvation* (2 vols., 1874); *Moses* (1876); *Practical Theology* (1878). Most of these works have been translated into English. Dr. Van Oosterzee contributed to Lange's great work commentaries on the Gospel of Luke, the Pastoral Epistles, and the Epistle of James. He left some works in manuscript, including an autobiography.

OPERA. This article is restricted to the history of operatic performances in the United States. Opera of any kind first made its appearance in this country, it seems, in 1750, when the *Beggar's Opera*, which had gained an immense popularity in England, was produced for the first time on the New York stage. This was soon followed by others. Bickerstaff's *Love in a Village* was produced in 1768, and his *Maid of the Mill* in 1773. Numerous others were given during the succeeding years, including *The Duenna* (1791); *Inkle and Yarico* (1793-4); a number by Dibdin; *Children of the Wood* (1794-5); *Blue Beard* (1801); *The Reviver* (1807); etc. The singers prominent at this time were Benjamin Carr, an Englishman, who later settled in Philadelphia as a music teacher, Miss Broadhurst, Miss Brett, Mrs. Oldmixon, who made her *début* here in 1798; Miss Catherine Leesugg, contralto; Miss Kelly, sister of the Irish composer, and the two eminent English singers, Philips and Incedon. During 1813-17 *Athia*, *The Miller and His Men*, *The Farmer and His Wife*, and *The Devil's Bridge*, all by a new English composer, Henry Bishop, were produced. In 1823 John Howard Payne's drama, *Clari the Maid of Milan*, was produced, with music by Bishop (among the pieces the now famous "Home, Sweet Home"). German music also began to be heard. In 1825 Weber's *Freischütz* was given, with great success—not entire, however, but "adapted" in parts.

At the same time that these English operas and operettas were being produced in New York, various French companies were performing the lyrical drama

in their own language in New Orleans, La. The first company of French comedians appeared there in 1791. But although, as Ritter says, "it is safe to presume that light musical farces and operatic pieces were enacted from time to time," the first positive date we have is 1810, in which year the *Barber of Seville* and *Romeo and Juliet* were presented. After this, and until the outbreak of the civil war, French opera was given frequently there, and the companies also made occasional visits to New York. Several opera-houses were built in succession, the latest completed in 1859. French opera, i. e., the light operetta (*opéra-bouffe*) of Offenbach, Lecocq, and other composers, first made its appearance in this country in 1867, when *La Grande Duchesse* was produced and had a run of 158 nights. Maurice Grau did much to popularize this kind of music, introducing to the American public a number of well-known French artists, notably Aimée, Judie, Paola Marie, and Theo. More recently, the English comic opera, as represented by Gilbert and Sullivan's *Pinafore*, and similar works, has found favor with the American public.

Italian opera made its first appearance here in 1825. In that year Garcia brought over a good Italian company to New York. *Il Barbiere* was the first opera given, followed by *Otello*, *Romeo e Julietta*, *Il Turco in Italia*, *Semiramide*, *Don Giovanni*, and others. But although Garcia's company included such excellent singers as his own daughter, Mme. Malibran, he had but poor success, and in 1826 went to Mexico. After this, and until 1832, operas were produced at various times in New York, but no work worthy of note was accomplished. In 1832 the tenor singer Montessor brought an Italian opera company to New York. A number of new works were produced, but the venture was a failure. In 1833 an opera-house was built, which was burned in 1839. An Italian company, under the management of Rivafinoli and Da Ponte, gave performances there, and collapsed, as a matter of course, as did also its successor, organized under the management of Porto and Sacchi. Among the artists in these two companies were Clementina and Rosina Fanti, Louisa Bordogni, Schneider-Maroncelli, Signors Fabi, Raviglio, De Rosa, and Porto. Meanwhile opera in English continued to make its appearance. In 1837 Mme. Caradori-Allen gave operas at the Park Theatre, and the Seguin troupe at the National Theatre. Two years later another English company appeared in opera, which gave, amongst other works, Beethoven's *Fidelio*, for the first time in America. The Seguins later had great success at the Park Theatre with the novelty, Balfe's *Bohemian Girl*, and Mrs. Anna Bishop and W. H. Reeves appeared in 1847. In 1843 a certain Palmò built a new opera-house in Chambers street, which was opened the following year. Italian opera was given there for four years, after which the place was abandoned as being too small. At this time a movement had been set on foot to have an opera-house built in a more convenient location. The enterprise was placed on a firm basis for five years at least, by subscriptions to support Italian opera for 75 nights a year during that period. The Astor Place Opera-House was opened in 1847 with Verdi's *Ernani*. The place came under the management of Salvatore Patti, who was succeeded by Edward Fry in 1848. Both had ill success, and Fry in turn was succeeded by his musical director, Max Maretzek. The latter gave Italian opera there for several years, producing a number of new operas, but the final result was the same, and the place was abandoned at the end of the five years. In spite of all the failures that had been witnessed, the hope of placing Italian opera on a firmer footing in this country was not abandoned. In 1853 the erection of the Academy of Music was begun, and it was opened the following year, Grisi and Mario among the singers who appeared. Maretzek gave opera here, as did also Maurice Strakosch (associated with Ullmann), under

whose direction Adelina Patti made her *début* in 1859. Mme. Lagrange, Mme. Frezzolini, and Carl Fornes were also in his company. Under Strakosch Christine Nilsson also came to the United States in 1870.

Various attempts were also made to introduce opera sung in German to the American public, the first probably in 1856, when Meyerbeer's *Robert der Teufel* was given, with Carl Bergmann as conductor. Carl Anschutz conducted German opera in New York in 1862, producing *Die Zauberflöte*, *Don Juan*, *Die Entführung aus dem Serail*, *Fidelio*, *Der Freischütz*, *Czar und Zimmermann*, and other works. New York had its first taste of Wagner when Bergmann, in 1859, brought out *Tannhäuser* at the Stadt Theatre. A second attempt was made in 1870, in which year Adolf Neuendorff brought a company from Europe and produced *Tannhäuser* and *Lohengrin*. He later gave also the *Walküre*, and it was also he who brought over Waeltel and Pappenheim. During the succeeding years Maretzek, the Strakosch brothers (Maurice and Max), Ullmann, Carl Rosa and Grau gave seasons of Italian opera, as did later Col. James H. Mapleson, whose musical conductor was Luigi Arditi, an excellent musician. It was to a great extent the "star" system which caused the final downfall of the Italian opera. The enormous salaries paid to the principal performers made it impossible to procure competent performers for the minor parts and to put the operas on the stage in a complete and satisfactory manner. When the Metropolitan Opera-House was erected in New York, Henry A. Abbey became manager, with a troupe that included Christine Nilsson, Marcella Sembrichi, Scalchi, Trebelli, Valeria, Fursch-Madi, Campanini, Stagno, Capoul, Del Puente, and Keschmann. At the end of this season of Italian opera there was, as usual, a deficit. Abbey refused to undertake another season, and the plan of giving German opera was then seized upon as a last expedient (1884). Leopold Damrosch became director, and in one month engaged his company, which comprised some of the greatest German artists. With this he gave a series of remarkable performances. Notable and novel was the careful attention to details, every part being carefully presented. It was a tremendous blow struck at the "star" system. Among the operas given were Wagner's *Tannhäuser*, *Lohengrin*, and *Die Walküre*, and Beethoven's *Fidelio*. Some of these, as we have seen, had been heard before in New York. Yet even the efforts of Bergmann and Neuendorff, though very creditable, had left much to be desired. Damrosch died in 1885, and was succeeded by Anton Seidl as conductor. His son, Walter J. Damrosch, who had conducted the opera during his father's illness, was appointed assistant director. In 1886, under the management of Edwin M. Stanton, Wagner's *Meistersinger*, *Parsifal*, *Rienzi*, and *Götterdämmerung* were given, and in 1887 Wagner's *Tristan und Isolde*, Brüll's *Golden Cross*, Verdi's *Aida*, Goldmark's *Queen of Sheba* and *Merlin*, and also *Faust*, *The Prophet*, Spontini's *Ferdinand Cortez*, Nessler's *Trumpeter of Säckingen*, Halevy's *Jocoss*, and Weber's *Euryanthe*. The principal singers that have appeared at the Metropolitan are Lilli Lehmann, Marianne Brandt, Auguste Seidl-Krauss, Albert Niemann, Max Alvary, Emil Fischer, Adolf Robinson, Stritt, and Staudigl. At this time there was also a company formed under the name of the "American Opera Company," with Theodore Thomas as director. It comprised some excellent singers, and operas were given for some seasons in New York and in other cities, but with indifferent success. In the season of 1887-88 Italo Campanini made an unsuccessful effort to revive Italian opera. With a company that included Galassi and Scalchi he gave Verdi's *Otello* at the Academy, New York. The performances showed the shortcomings which always characterized representations of Italian opera, and this attempt emphasized more strongly the fact that Italian opera had been driven from the field.

A distinct operatic school does not yet exist in America, although a number of native composers have tried their hands at that form of composition. Probably, the first "American" opera produced here was William Duulap's *Archers*, brought out in 1796, with music by Benjamin Carr, who came to America in 1794. Duulap's *Vintage* was produced in 1799, with music by Victor Pelissier, a Frenchman residing in New York; who also wrote the music for E. H. Smith's *Edwin and Angelina*, produced in 1798. Another opera by Duulap was brought out in 1800, with music by James Hewitt, who, like Pelissier, was a well-known orchestral leader. More notable efforts are *Rip Van Winkle*, by George F. Bristow, produced in 1855, and *Leonora* (1858) and *Notre Dame de Paris* (1864) by Wm. H. Fry. These three, as also Julius Eichberg's *The Doctor of Alcantara* (1862), enjoyed a certain degree of success. The number of operas by American composers is very large, but most of them are of a light character, modelled after the French operetta. They are, as a rule, marked by no originality, and have met with poor success. One of the latest native productions in grand opera is Silas G. Pratt's *Zenobia* produced at Chicago in 1882, which, though good in parts, was not very well received.

America has produced a number of singers of note, among them Clara Louise Kellogg, Adelaide Phillips, Emma Juch, Minnie Hauck, Emma Abbott, Marie Van Zandt, Emma Nevada (Emma Wixon), and others.

For fuller accounts of the opera in America see Frederic Louis Ritter's *Music in America* (New York, 1883), Maurice Strakosch's *Souvenirs d'un Impresario* (2d ed., Paris, 1887), and Max Maretzek's *Crotchets and Quavers* (New York, 1855). Numerous magazine articles on this subject have been written by Carl Rosa, Henry T. Finck, and others.

(F. L. W.)

OPIUM is obtained from the capsules of the poppy and is one of the most complex drugs known to *Materia Medica*. It has been raised in the United States, but on account of the price of labor and the climate, without profit. The term "opium-eating," by which the habit of using it is commonly designated, is a misnomer, for in no proper sense is opium taken by the eating process. Among opium-takers the object, either for relief of pain or stimulation, is obtained by one of four methods, viz., draught, bolus, injections, and pipe. Of the first, the best known and most popular preparations are morphine in solution, laudanum, black drops, and paregoric. The second method consists in swallowing a pill made of the crude drug, or in combination with other narcotics. The alkaloids and salts extracted from opium come under this head. The medicinal *pitula opii*, sulphate of morphia, and codeia are the principal forms in vogue. The famous *Mash Allah* (the great gift of God) and *el magen* of the orientals may also be included in the bolus method. The former, made of opium and aromatics, is fashioned into lozenges and much used in Turkey. The latter is a conserve in which hyoseyamus is the adjunct and is found principally in Cairo. The third mode of placing the system under the desired influence is by injecting a solution of morphia by the hypodermic syringe, the place generally used being the arm. This method has found favor among literary and professional persons, perhaps because the drug acts more quickly and a smaller quantity will suffice; and it does not leave the peculiar nauseating after-effect which is often experienced by the other methods. Physicians invariably resort to the hypodermic syringe. This plan is doubly dangerous, on account of the liability at any time to pierce a vein; and because, with many, there is a certain fascination about the instrument which renders it more difficult for them to be cured of the habit. The syringe very often produces painful abscesses, and in every instance leaves scars and marks which may never be obliterated. The

pipe method consists in setting fire to a small piece of the chandoo, or smoking opium, about the size of a pea, and then inhaling the smoke through a pipe constructed for the purpose. Experienced smokers make full inspirations, swelling the lungs to their full expansion, and after retaining the smoke as long as they possibly can, exhale it through the nostrils. The pipe method is practiced for the most part in China, Turkey, and the Indian Archipelago. In San Francisco and New York nearly all the Chinese population smoke opium. This mode, however, is not exclusively confined to foreigners, for some Americans use the drug in combination with their tobacco; and it has recently appeared that an American opium-smoking society exists in a Western town. In the Ottoman and Chinese empires, and also in India, opium, either in bolus form or by means of the pipe, is used extensively by rich and poor.

Opium differs widely in its injurious effects, according to which of the different ways is adopted. The weight of opinion is that smoking is the least injurious. The effects of the drug, although exhilarating for a time, are purchased at a fearful cost. The smoker of the pipe progresses toward the final wreck with increasing pallor of eyes and face, that, once seen, can always be recognized. The morphine-eater shows a somewhat similar condition, varied by a tendency to pimples and eruptions, the result of the paralyzing effect of the drug upon the bodily functions and secretions. In all phases of the habit the will power is entirely subordinated. The victim is helpless. Any delay in taking the usual dose results in horrors of which the snake-seeing drunkard never dreamed. The stomach is gnawed by the terrible appetite as with the sharp teeth of some wild animal; pains rack the body and limbs; the head is also affected, and a general feeling of being on the very verge of total collapse invests the sufferer with a dread that is indescribable.

In the United States the use of opium in places called "joints" has been restricted to large cities, especially New York and San Francisco. In New York the joints became, for a time, the haunts of somewhat fashionable men and women; but since the passage of the State law, making it an offence to keep an opium-joint, places of this sort have disappeared. There is no law against the smoking of opium; but the enactment against the maintenance of places of that nature has given the police control of the matter. In spite of this practical prohibition to others the Chinese appear to be free to smoke the drug at joints as much as they please. Among the medical profession opinion is very much divided as to the nature of the intoxication produced by opium; but it seems to be agreed that there is no substitute for it, and no antidote. It is also practically agreed that the only method of curing the opium habit is for the patient to abandon the drug; whether he is to do so at once and forever, or by a retrogressive plan, diminishing gradually the dose of the accustomed stimulant, is a question upon which a diversity of opinion exists. The mode of treatment is determined by the experienced practitioner according to the peculiar circumstances of each individual case, and the constitution, character, and general make-up of the patient. But, in any event, there is one fate that awaits the victim, and he must firmly determine to brave it and bear it. At some time during the treatment, whichever mode it may be, he will have to endure much suffering, though he may be assured that competent physicians will use all the resources which medical science has placed at their command to ameliorate the distress. The disease is certainly vincible; and with a resolute will and proper treatment the victim can eventually come off victorious. It is evident that the use of opium as a stimulant is increasing in the United States. Some members of the medical profession state that this is because the use of whiskey is becoming less common; and they also say that while whiskey excites to quarrels, opium is more

disastrous to morals because the opium-eater will stop at no deceit, and sometimes hesitate at no crime, to possess himself of the drug. It is thought that one cause of the spread of the habit is the superficial knowledge of the drug and whatever remedies are supposed to be antidotes for its use. It has been suggested that physicians should make up the medicines they prescribe without letting the patient know of their composition; and that the use of syringes should never be within the sight of the patient, nor should the physician teach the use of them to patients.

All opium prepared for smoking comes from China, where the right to prepare it is sold by the government to the highest bidder for a term of years. The amount of crude opium imported in the United States in 1872 was 189,354 lbs.; in 1880, 243,211; in 1886, 471,276, and in 1887, 568,263 lbs. The price per lb. rose from \$2.50 in 1886 to \$4.75 in 1887 and still higher in 1888. The crude opium comes almost exclusively from Smyrna, being a product of Turkey in Asia. The chief place of importation for smoking opium is San Francisco. The importations of smoking opium in the United States for different years have been as follows: 1872, 49,375 lbs.; 1880, 77,196 lbs.; 1886, 46,207 lbs.; and 1887, 66,232 lbs. The U. S. government prior to 1883 imposed a duty of \$6 a pound upon opium for smoking; and since 1883 the duty has been \$10 a pound. The falling off since 1880 was probably owing to the increased duty; but there is suspicion that the actual amount was made up, if not increased, by smuggling. (F. G. M.)

OPOSSUM, or POSSUM, are English forms of the native Indian name of a marsupial mammal which inhabits a large part of the United States, distinctively called *Virginian opossum* by Pennant.

See Vol. XVIII. p. 796 (p. 819 Am. Rep.).

in 1781, and technically *Didelphis virginiana*, first by Shaw, 1800. The form "possum" occurs in Lawson's *Carolina* (orig. ed. 1709) and is nearer the native original than "opossum," which is applied in Catesby's *Carolina* (orig. ed. 1731-48), and has always been the most current form, of which "possum" is supposed to be modified by aphæresis. The word in either form came to be applied: (a) to all the representatives of the Linnæan genus *Didelphis* (1766). These were five in number: (1) *D. marsupialis*, based on the philander of Seba, the opossum of Tyson, the carigue or carigucya of De Laet, Marcgrave and others, the maritacaca of Ray, and the tlaquatzin of Hernandez, being thus a composite species. (2) *D. philander*. (3) *D. opossum*. (4) *D. murina*. (5) *D. dorsigera*. These species are mostly based upon descriptions given by Seba; all are said to be American ("Asia" very wrongly added as the habitat of one of them, *D. murina*). The Linnæan genus *Didelphis* (more correctly to be spelled *Didelphys*) corresponds to the modern family *Didelphyidae*, which is the only group of marsupials living in America, and includes the whole of the American marsupials, all the rest of the order *Marsupialia* being confined in the present geological epoch to the Australian zoogeographical regions. Thus the word "opossum" or "possum" came to mean "any American marsupial," of which there are several different genera and numerous species, ranging from middle portions of the United States to Patagonia. But (b) prior to 1800 the name "opossum" had been loosely extended to certain old world marsupials, in the vague manner which is not exclusively a fault of travellers and amateur naturalists, but also found in the writings of professed zoologists. Thus we read in Pennant of a certain "Javan opossum" which is a kind of kangaroo called "filander" by Le Brun in 1711, inhabiting some of the Papuan islands (but not found in Java); and various Australian marsupials, especially among the phalangers, are persistently called "opossum," with or without a qualifying term.

Returning to the proper definition of the term, as the name of "any American marsupial," and of no

other animals, thus corresponding in application exactly to the zoological family *Didelphyidae*, we may note that it covers two very distinct genera. One of these, *Chironectes*, contains the curious web-footed water-opossum or yapock of South America. The other is *Didelphys*, containing all the rest of the species, which vary so much in size, shape, degree of development of the mammary pouch, and other characters that they are often subdivided into several modern genera. One of these contains the small three-striped opossum of Brazil, *D. tristriatus*, and is called *Hemivurus* or *Microdelphys*. A second has as its type the tiny mouse-like opossum, *D. murina*. A third includes larger species characterized by the absence or slight development of the pouch, as in *D. dusigera* or *D. derbiana*, the young being carried on the back of the mother with their tails wrapped around hers. This group is called *Metachirus*, and its members grade into those of the fourth and last and best known division, *Didelphys* proper, which contains such large species as the crab-eating opossum of tropical and subtropical America, *D. cancrivorus*, and our own familiar Virginian opossum, *D. virginiana*.

This animal, to which we will now confine attention, abounds in the Southern States, extends into the Middle, and has occasionally been seen as far north as New York. It is about as large as a domestic cat, measuring 18 or 20 inches in length of head and body, with a tail of 12 to 14 inches; but individuals vary much in size. The head is conical, tapering to a long snout, somewhat like a pig's; the eyes are small and placed high up; the ears are large, high, rounded, thin, and nearly naked. The body is stout, and seems still thicker from the long, loose, and fluffy hair with which it is covered, overlying a copious short under-fur. The general color is gray, darkened on most parts with the blackish ends of the longer hairs. The limbs are short, and all four end in a kind of hand; for the opossum is pedimanous, or "foot-handed." There are five digits on each foot, all with claws excepting the inner toe of the hind foot, which is apposeable to the others like a true thumb. The hands and feet are covered in part on the backs with short fur, but naked and callous on the palms and soles. The tail is long, cylindrical-tapering, naked and scaly in most of its length, and perfectly prehensile, so that it constitutes a serviceable "fifth hand."

The teeth are no fewer than 50, and of 4 kinds, indicating an omnivorous animal of carnivorous propensities, like the pig. The dental formula is: $i. \frac{4}{4}; c. \frac{1}{1}; pm. \frac{3}{3}; m. \frac{1}{1} - \frac{1}{1} \times 2 = 50$. The canines, especially the upper ones, are highly specialized.

The sexual organs and mode of generation of the opossum, so entirely exceptional among American mammals (outside of the family *Didelphyidae*), have given rise to wild and very gross beliefs among the negroes, some of which have been repeated beyond the vulgar. Thus it is said that coition takes place in the nostrils of the female; and the young grow upon the teats in the pouch, in consequence of the deposit of the sperm by the sneezing of the female into the pouch. But the genesis of such stories is easy to trace. In the male, the scrotum hangs loosely from the belly near the navel, and there are no outward signs of other genitals. This is because the penis is retractile, and ordinarily withdrawn within the same sphincter which guards the orifice of the anus. In copulation it protrudes from the anal orifice to the extent of about 2 in., and is forked at the end. It is furnished with several intrinsic muscles, for protrusion, retraction, erection, and the separation of the two prongs, so that each fork shall enter the corresponding (right and left) vaginal passages of the female. For in this sex the internal organs of generation are completely double, right and left, and both debouch externally by a single orifice not distinguishable on ordinary inspection from that of the anus. So that the female, like the male,

appears to be devoid of external genitals, and coitus seems to be effected per anum. The chief peculiarity of the female, externally, thus subsists in the pouch or *marsupium*, characteristic of the whole order *Marsupialia*. It is fully developed in the Virginia opossum as a furry bag on the belly, formed of a duplicature of the skin, with its mouth directed forward, and the walls furnished with appropriate contractor muscles. In the virgin opossum the pouch is inconspicuous, and scarcely admits the ends of two or three of our fingers; after bearing young, however, it is much larger, so that the whole of one's fist may be thrust into it. Inside the pouch, in the skin of the belly-wall, are the teats to the number of 13, twelve in a circle and one in the middle. The young are born after a few days' gestation (probably less than two weeks), in a very imperfectly developed and entirely helpless state, about as large as peas. They are immediately transferred to the pouch by the voluntary action of the mother, either with her lips or paws, and at once each one of them becomes firmly attached to a teat by the mouth, hanging like berries to a stem. In this state they grow rapidly, never letting go their hold until they have attained some size. As soon as they are capable of spontaneous actions, beyond the automatic act of suction, they may let go and take hold again when hungry, like the young of ordinary animals. Soon after this they may be seen putting their heads out of the pouch; then their first excursions are made over the body of the mother to the limbs, and especially the tail, to which they cling, and retreat into the pouch when alarmed as long as it is able to hold them. When grown too large for this, they ride about on the mother's back in a bunch, and at length leave her to shift for themselves, being at this time about the size of kittens a couple of weeks old.

The opossum is nocturnal, like most marsupials, and its hunting affords, with that of the raccoon, the characteristic sport of the Southern States. It is chased and treed by dogs at night, and either shaken out of the tree to which it takes refuge, or shot as it hangs by the tail. Its flesh is palatable, and resembles pork, especially in the fall, when it is chiefly hunted, and when it acquires a thick layer of fat all over the body. Its teeth are sharp, and capable of biting severely; but the opossum is a very timid and one of the most defenceless of animals of its size. It is tolerably active among trees, but its gait on the ground is a slow and shuffling amble. It spends most of its time during the day hiding in hollow logs and like retreats, and at night forages for its food, which consists of any small animals it can catch and overpower, as birds and their eggs, reptiles, insects, worms, etc., as well as various berries and other fruits, especially persimmons. It readily eats any kind of carrion, as a dead horse or cow, and often attacks domestic poultry. It has no voice beyond a kind of hissing, and a low growling when irritated.

There remains to notice one of the most remarkable of the opossum's traits—its habit of feigning death when at the mercy of its captors. Though ordinarily so timid, no amount of torture can then draw from it a sign of suffering. Such endurance, joined with remarkable cunning, frequently enables the creature to escape what would otherwise prove its destruction; and these traits have even given to the English language a proverbial expression of peculiar significance, the phrase, "Playing possum." (E. C.)

OPPERT, JULES, French Orientalist, was born at Hamburg, July 9, 1825. He is of Jewish descent and was educated at the University of Heidelberg, Bonn, and Berlin. In 1847 he took the degree of Ph. D., at the University of Kiel, and then studied chiefly the Zend language and literature. Being excluded from professorship in German universities on account of his religion, he went to France, where he became professor of German at Laval and at Rheims. He was sent in 1852 on a scientific expedition to Mesopotamia, and on his return was naturalized as a Frenchman. In 1854

he laid before the Institute his method of deciphering the cuneiform inscriptions and received the grand prize of 20,000 francs. Oppert also studied carefully the topography of ancient Babylon, and presented to the geographical department of the Institute a plan of that city. In 1857 he was made professor of Sanskrit in the school attached to the Imperial Library. In 1869 he began to teach also in the Collège de France and in 1874 was made full professor there. Among his works are *Études assyriennes* (1858); *Grammaire sanscrite* (1859); *Histoire des empires de Chaldée et d'Assyrie* (1866); *Babylone et les Babyloniens* (1869); *Mélanges perses* (1872); *Le peuple et la langue des Mèdes* (1879); *Fragments cosmogoniques* (1879); *Fragments mythologiques* (1882); *L'ambre jaune chez les Assyriens* (1880).

His brother, ERNST JACOB OPPERT, born at Hamburg in 1832, went to China in 1851 as a merchant, and made several visits to Corea, the results of which were published in *A Forbidden Land*, London (1879).

Another brother, GUSTAV SOLOMON OPPERT, born in 1836, was employed for some time in the Bodleian Library, and became professor of Sanscrit in the University of Madras in 1872. He has published treatises *On the Classification of Languages* (1879); *On the Weapons of the Ancient Hindus* (1880); *Contributions to the History of Southern India* (1882).

ORANGE is the fruit of *Citrus aurantium*, and perhaps of other species of *Citrus*, though long-continued cultivation has rendered the specific relations of the varieties of oranges somewhat doubtful. The genus *Citrus* and its allied genera were formerly classed as the orange family, *Aurantiaceæ*, but they are now considered to form a subdivision of the *Rutaceæ*, or the rue family. The members of the genus *Citrus* are shrubs and low trees, often spiny, with aromatic, evergreen leaves. The flowers are very fragrant. There are not many species in the genus, and they are all natives of the tropics. The fruit is large, thick-rinded, and separated by partitions into numerous divisions, its few seeds being surrounded by large, juicy cells. The wood is hard, heavy, and close-grained. The leaves, the flowers, and the rind of the fruit abound in aromatic oils, while the juice of the fruit pulp contains citric acid.

The orange derives its specific name from Latin *aurum*, gold, in reference to its color. The common English name is a modification of the same, coming from the French. The flower of this species has five white petals, of oblong form, the anthers 20-anded, with their filaments grown together, so as to form various pencils. The flowers grow in little clusters on the sides of the branches. The fruit is a nine- to twelve-celled berry, globose or flattened at the ends, with a thin or rough golden yellow or tawny rind, and sweet or bitter-sour pulp. The rind is of spongy texture, with little glands which secrete an acrid volatile oil, with a strong, pungent taste. *C. Bigaradia* is a prominent variety of *C. aurantium*, and is notable for the fragraney of its flowers, from which is made the delicate and costly perfume, Neroli oil. The sweet orange is not so fragrant, and as a perfume-yielder is of less value than *C. Bigaradia*. This specific name but indicates a variety, as there is no specific distinction between the bitter and the sweet orange.

Under favorable circumstances the orange-tree is usually twenty-five or thirty feet high, and is graceful in all its proportions, the trunk being upright, the branches symmetrical, the bark of a delicate ash-gray color. The leaves are moderately large and shiny on the upper surface, with a slight appearance of down beneath. The flowers are of a delicate white color. The delightful aroma and the pure whiteness of the orange-flowers have long made them the favorite blossoms for the bridal-wreath. The orange is a native of South-eastern Asia, and seems to have been brought by the Arabs to Arabia and Syria in the

eleventh century and to Spain at a later date. This appears to have been the bitter orange, the sweet not being cultivated in these regions till perhaps the fifteenth century. From these countries it has been disseminated until now it is grown widely throughout the warmer regions of the globe. It is a long-lived and prolific tree, there being at Cordova, Spain, a number of monster orange-trees which are known to be 700 years old. The trunks are partly hollow and the bark cracked, yet they are still in good bearing.

The orange blooms but once a year, yet it seems often to have flowers, young fruit, and mature fruit on it at the same time. This comes from the habit in some regions of letting the fruit of the preceding year hang on the branches. In Italy the fruit intended for shipment is picked green, while that kept for home consumption remains on the trees all winter and reaches perfection in the succeeding spring and summer. It takes about fifteen years from the time of sowing before the orange comes to full bearing, but the delay in this respect is more than compensated by its persistence as a fruit-bearer. This is particularly the case in view of the fact of its frequent great bearing powers. It is said that as many as 20,000 oranges have been borne on a single tree in the Azores, while half this bearing to a single tree has been observed in Florida. As a rule an orange-tree bears from 500 to 2000 yearly.

In addition to the oil of Neroli (which gets its name from having been used as a glove perfume by the wife of the Prince of Neroli), the orange yields several useful products. The water from which the oil is separated is sold as orange-flower water, while what is known as oil of orange is obtained by squeezing the peel. A tea is made from an infusion of orange leaves which is considered efficacious in fevers, while the seeds yield a fixed oil of amber color, which is valued for reducing swellings and as a hair oil. In the French colony of Martinique large quantities of orange wine are made, which finds a ready sale in Turkey and Russia.

The orange is a surface-feeding plant; old trees make the surface a network of fine rootlets. Its culture is rapidly on the increase, the facilities of transportation to Northern markets and the cheapness with which it can be sold having greatly increased the consumption within recent years and brought many new regions of growth into competition with the old sources of supply. In the United States Florida has become an important orange-growing State, its fruit being of an acknowledged excellence which renders it a formidable rival to the oranges of Southern Europe and the West Indies, our former sources of supply. The superior ripe fruit which we receive from the Florida plantations is already superseding the half-ripe fruit hitherto shipped in enormous quantities to the United States.

On the settlement of Florida immense groves of wild orange-trees were found, so widely spread and so prolific that they were at first supposed to be indigenous, though it is now known that they must have been introduced by the early Spanish settlers. These oranges were of the bitter variety, the only one known in Europe at that date. Subsequently the Spaniards introduced the sweet orange, and both these varieties are now found wild, together with a hybrid, the bitter-sweet orange.

One of the pioneers in this culture was an Englishman, named John Eaton, who settled in Florida in 1837 and budded a grove of fifty wild trees with buds from the sweet orange. The result was highly encouraging. The bitter orange trunks proved excellent stocks for budding, and these fifty trees are still in full bearing, being said often to net \$1500 to \$1800 per season. One tree of this grove is the famous "Big Tree" of Florida, which often bears 10,000 oranges in a single season, and these of the finest quality. The other trees bear from 2000 to 5000 each.

Oranges grow luxuriantly in a considerable variety

of soils, and much land in Florida formerly unused is now devoted to orange-culture. High dry land and low moist soil seem alike suitable, while many groves are planted in the low hammock lands, under the shade of the giant oaks which there flourish. An orange-tree in full bearing is said to be valued at \$100 all over the State. Orange-trees are raised from the



Orange Gathering.

seed or are produced by budding and grafting the wild stocks. Culture from the seed takes much care, and among the enemies of the young plant one of the most dangerous is the ant, which seems to consider the embryo leaves a delicacy and is apt to bite them off as soon as they come above the ground. Hard-wood ashes and air-slacked lime are used to keep off this foe. Some orange-growers simply clear out the superfluous plants from a wild grove and bud the remainder. Others set out young wild trees and bud them, while still others bud stocks raised from the seed. There is a difference of opinion as to which of these methods is the best and most profitable, but it is generally considered that the bitter orange-stock, from its superior hardiness, is far superior to the sweet orange as the basis of a grove. Almost any soil but heavy clay is suitable, but severe frosts are fatal to the orange. This fact renders the shelter of oak groves, above alluded to, of value.

The orange has a variety of insect enemies. Fortunately none of these are borers, but all are open foes, which may be easily detected. One of the most injurious of these is the scale insect parasite, which first appeared about 1868 on some orange-trees introduced from China and quickly spread over the whole State. The growers have now learned how to fight it, and its ravages have been greatly reduced. A kerosene wash is used for this and the mealy bug, another juice-sucking parasite. The leaf-footed plant-bug is an enemy that can only be killed by gathering and scalding. There are various other insect enemies, among them the grasshoppers and katydids, who do great damage by devouring the leaves.

The area in Florida thoroughly adapted to orange-culture has been estimated at 10,000 square miles, a space capable of yielding an enormous crop. The sweet orange raised in this State is of the finest flavor, and has no superior in size, productivity, and general good qualities. A single acre has been known to produce ten tons of oranges, and this industry promises to become one of the highest value not only to the State but to the whole Union. Another locality of the American orange is Louisiana, the trees having been probably introduced there from Florida. The Louisiana oranges resemble those of Florida, though the yield per tree is said to be much greater. The favorite orange district in this State extends along the west bank of the Mississippi from a point about forty miles below New Orleans to the vicinity of Fort Jackson. For thirty miles in length there is an almost continuous orange-grove, some of the orchards being very large.

There are trees here said to be more than a hundred years old, which are still producing fruit.

The Louisiana produce is supplied to the people of the Mississippi Valley, as the Florida yield is to the Atlantic cities. To the Mississippi region comes also a considerable supply from California, the third important region of orange-culture in the United States. In Southern California large crops of oranges are raised, which, like Californian fruits generally, are of enormous size, but are said to be deficient in flavor as compared with those of the East. The cultivation of the orange within recent years has extended northward, until now excellent crops are produced in the valley of the Sacramento River. Its culture, indeed, may be enormously extended in the State, the principal check being the difficulty of finding a market for the crop. The Eastern market bids fair to be fully pre-empted by the Florida and Louisiana supply.

ORBIGNY, ALCEDE DESSALINES D' (1802-1857), a French naturalist, was born at Coneron, Sept. 6, 1802. He was educated at La Rochelle, and in 1826 went to South America, where he spent eight years in scientific exploration from Brazil and Peru to Patagonia. In 1852 he was appointed professor of paleontology at the Museum of Natural History at Paris. He died at Pierrefitte, June 30, 1857. Among his works are *Voyage dans l'Amérique du Sud* (9 vols., 1834-52); *Paléontologie française* (14 vols., 1840-54). He contributed to the *Dictionnaire Universel d'histoire naturelle* (24 vols., 1839-49), edited by his brother, Charles Dessalines d'Orbigny (born in 1806), conservator of the Museum of Natural History of Paris.

ORCHARDSON, WILLIAM QUILLER, a British artist, was born at Edinburgh in 1835. After studying art at the Trustees' Academy he painted portraits until 1863, when he removed to London. His pictures exhibited at the Royal Academy attracted favorable notice. Among these were *Flowers of the Forest*, *Hamlet and Ophelia* (1865), *A Hundred Years Ago* (1871). He was made an associate of the Academy in 1868, and a member in 1877.

ORCHIDS. Members of the *Orchidaceæ*, or orchid family, one of the most extensive orders of plants, including in all 394 genera and about 3000 species. They are endogenous herbaceous shrubs,

always perennial, and occurring all over the world, except in the coldest and driest regions. In the colder localities they are generally terrestrial, but in the tropics are usually epiphytic, growing on stones and trees, and deriving their chief nutriment from the air. They are distinguished by irregular and often very beautiful flowers, which are often of remarkable shape, closely resembling some insect, bird, or reptile. This is caused by the variation in shape of one of the petals, the labellum, or lip, which becomes greatly transformed, and gives the flower its imitative resemblance. Another distinguishing feature is the adherence of the pollen in grains or waxy masses, and the one-celled inferior ovary.

The orchids are nearly always fertilized by insects, to which fact is probably due much of their singularity of form and also their frequent great fragrance. Some of them have thickened root-stocks which form underground tubers. Others swell into a tuber-like body, called the pseudo-bulb, above ground. The leaves are greatly varied: some being thin and temporary, others thick, fleshy, and persistent; some spreading into a broad foliage, others long and slender, like whip-cord. There are few useful plants in the order, extensive as it is, the vanilla being the only orchid of marked commercial value.

The United States has comparatively few native species of this great order. Of late years, however, florists have succeeded in successfully cultivating in greenhouses many tropical epiphytes, they being greatly admired for their beauty or singularity. The great variety of orchids necessitates variation of method

in their cultivation. The terrestrial forms are propagated by division of the tubers, or of the pseudo-bulbs, each piece having one or more. Those with aerial roots are similarly propagated by division, the seed being rarely used for this purpose. In choosing soil for the ground-growers the question of nutriment is not important, as these plants depend very little on the soil for their food. The best soil is one that is not retentive of moisture. The whole order, with the excep-



Orchid (*Odontoglossum Rossi*).

tion of the comparatively few true terrestrial species, derive the most of their nutriment from the air, and seem to grow best attached to blocks of wood, or placed in baskets and hung from the roof of the greenhouse. They seldom need water at the roots, but require an abundant supply upon their foliage, particularly during their season of active growth. They need to be shaded from intense sunlight, but not from the ordinary light of the sun. *Odontoglossum Rossi*, of which we give an illustration, is an excellent variety for growing in baskets or on blocks in greenhouses. Its season of growth is during the summer, yet its magnificent flowers are produced in winter.

ORD, EDWARD OTTO CRESAP (1818-1883), an American general, was born in Allegheny co., Md., in 1818. His father, James, was an officer in the war of 1812. He graduated at West Point in 1839, and served against the Seminoles. He was on duty in California in 1847-49, and again in 1855. He was ordered to Harper's Ferry at the time of John Brown's raid in 1859. In 1861 he was made brigadier-general of volunteers, and commanded a brigade in the Pennsylvania Reserves. He defeated Gen. J. E. B. Stuart at Drainesville, Va., Dec. 20, 1861, and was made major-general May 2, 1862. Being then placed in command of the left wing of Grant's army at Corinth, Miss., he took part in the battle of Iuka, and was wounded at Hatchie, Oct. 5, 1862. He commanded the Thirteenth corps at the siege and capture of Vicksburg and at the capture of Jackson. In July, 1864, he commanded the Eighteenth corps in the siege of Richmond, and was wounded at Fort Harrison, Sept. 29. In January, 1865, he relieved Gen. Butler of his command in Virginia and North Carolina, and commanded the Army of the James at Petersburg and in the pursuit and capture of Lee. When mustered out of volunteer service he was made brigadier-general in the regular army, July 26, 1866. He had military command of the States of Arkansas and Mississippi in March, 1867, and afterwards of the departments of California and of Texas. In January, 1881, he was placed on the retired list, and thereafter he lived in Mexico, his daughter having married the Mexican general, Trevino, in July, 1880. He died at Havana, July 23, 1883, while on his way to New York.

ORDNANCE. Before the invention of gunpowder, slings, javelins, bows, cross-bows, and rams were used as weapons, with which success largely depended upon the physical strength of the one using them, but the

gun came in as the great equalizer of mankind; with it the physically weaker became the equal of the physically stronger, and with it the reign of brute force came to an end. From the individual to the nation is but a step, and to-day all nations are actively engaged in providing themselves with suitable defences, as wars now must be short, and the nation best equipped and armed has a decided advantage.

An international war is now waging, wherein the rivalry is as intense as in the actual meeting of opposing forces. This war is carried on in the forge and machine-shop and not in the field, but the results are watched with the keenest interest, and the consequent progress in the destructive arts of warfare is most impressive. The recognition by Congress of the fact that the United States should have suitable land and naval defences has led in the last few years to liberal appropriations for guns, and, in the near future, guns equal in size and destructive efficiency to those of any other power will be produced in this country.

A brief description of the various classes of ordnance and their parts will aid the non-technical reader in following the progress of gun-making, as the beginning has already been made and guns turned out for the army and navy that warrant the belief that our guns when built will be second to none in the world.

Guns or heavy cannon are distinguished as rifled and smooth-bore; rifled guns having spiral grooves, which impart a rotary motion to an elongated projectile having projections or soft-metal bands, which enter the rifle-grooves. The smooth-bore gun has no grooves, and fires a spherical projectile. Guns are likewise distinguished as muzzle- and breech-loading, these terms explaining themselves, and as cast and built-up guns.

The breech of a gun is the mass of metal in rear of and around the bottom of the bore. The trunnions are cylindrical projections for supporting the gun on its carriage, placed on opposite sides of the gun in a horizontal plane, with the axes in the same line at right angles to the axis of the gun. The diameter of the bore is called the calibre of the gun. The chamber of the gun is that portion of the bore containing the charge. The vent is the channel from the exterior to the chamber through which fire is communicated to the charge.

There are two methods in general use of closing the after end of the gun when it is loaded from the breech: one by inserting a block into the bore from the rear, and the other by pushing in a block through a transverse opening across the bore. The former is in use in France, England, and the United States, and is known generally as the French system, though it is the outcome of an American patent of 1849, by Chambers, repatented in a different form by Schenck in 1853, and used in the construction of six guns for the English government, in 1855, at Boston, after the design of an American named Castmann.

The block is a cylinder of steel, upon which a screw-thread is cut, portions of the thread being cut away, leaving three blank spaces on the block running lengthways, and in the female-screw cut in the bore of the gun, into which the screw on the block is to engage, three similar blank spaces are left. The threaded portions of the block are brought opposite the corresponding spaces in the breech-screw, and then the block is forced in to nearly its full extent, and a sixth of a turn engages at the same time all the threads of the block with those in the breech. The same fraction of a turn back disengages the screw by bringing the threads of the block in the open spaces of the breech, and the block can be withdrawn. It rests on a bracket hinged to the side of the breech, so that it can be turned aside out of the way when the gun is loading. The vent is in the axis of the block, and escape of gas through it is prevented by an ingeniously arranged slide, which acts automatically as the breech is being closed, and prevents firing till the breech-block is in place.

With guns of large calibre where the breech-block is of great weight, it is turned, pulled out and drawn to one side by hydraulic, pneumatic, or steam power. The charge of powder is fired by means of a percussion primer which is struck by a spring lock, pulled from a distance of several feet by a string or lanyard.

A section of a breech-block is shown. The charge rests against a mushroom-shaped part, with a stem running through the block proper. To prevent the escape of the gas past the block a gas-check, or *obturateur*, is employed. This consists of a linen collar (C), filled with a mixture of 65 per cent. asbestos and 35 per cent. mutton suet, fitting snugly around

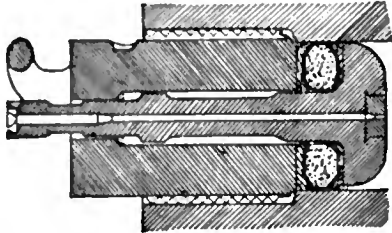

Gas-Check.

and just under the movable head. The collar is enclosed and protected by steel rings, maintaining the form of the plastic material. When the gun is fired the pressure upon the movable head is transmitted to the gas-check, which is forced out against the sides of the chamber, causing perfect obturation. The second method of closing the breech, known as the Krupp mechanism, is on the wedge plan. The breech of the gun is extended for a considerable distance in rear of the chamber, and a hole is cut through the gun horizontally, in which slides a cylindro-prismatic, or **C**-shaped breech-block. The plane-face slides across and closes the end of the bore. On this face a shallow circular recess is cut, and in it placed a thin disc of copper, over which is a steel plate. Against this presses a steel ring, with annular grooves at the back, which, expanding against the steel face of the plug and the walls of the bore, prevents the escape of the gas. This wedge is a modification of the invention of Mr. Broadwell, an American, and the gas-check ring is likewise his invention, and is called the Broadwell ring.

Mortars are short, heavy pieces of ordnance, with large bores, throwing shells at high angles, so that they may fall upon an enemy's ship or into his forts, and other places that cannot be reached by horizontal fire. Howitzers are light-shell guns firing large projectiles at low angles with small charges of powder. They are made both smooth-bore and rifled.

Machine-guns, while not strictly coming under the head of ordnance, will be described. These are guns with which rapid service is obtained by having the projectile and powder charge put up as a cartridge, so that they need not be loaded separately. They are termed machine-guns, revolving cannon, and rapid-fire guns, the distinction between the first two and the rapid-firing gun being the same as between a revolver or magazine-rifle and a single-barrelled breech-loader, which must be loaded after every fire.

Guns are cast either solid or hollow; in the latter case cooled from the inside, and are then turned to the proper shape on the exterior and bored. The terms "built-up" and "hooped" are applied to guns wherein the gun is made in parts which are afterwards united by shrinking one part on another.

The latest English guns as well as our own are built on the system of Mr. J. Vavasseur, of England. The gun is composed of an inner tube of steel as thin as is consistent with strength, having a long jacket shrunk on to provide longitudinal strength, with layers of superimposed cylinders or hoops shrunk on, the number varying with the size of the gun. The general method of procedure is as follows:

The gun-tube, jacket, and hoops are obtained from the steel-maker, accepted only after the most rigid tests, rough-bored and rough-turned. The tube is turned to nearly the size required for receiving the jacket, then tempered in oil and then turned to the proper finish. The tube is then placed vertical in a pit, muzzle down, and water is pumped in to keep it cool. The jacket is then raised to a red heat, lifted from the furnace and lowered over the tube. Gas and water jets are employed for heating and cooling such portions as require it. When cold the gun is put in a lathe and the jacket turned for the first layer of hoops, and these are shrunk on in the same manner as the jacket, and after cooling are turned down for the next layer, and so on till all are in place. The gun is then finish-bored and ground, the trunnion band screwed on, the bore turned out, rifled, and the breech-screw cut.

Guns are also made of cast-iron bodies with wrought-iron and steel bands shrunk on to strengthen them. Cast-iron smooth-bore guns have been converted into rifles after various systems, the principal being those of Major Palliser, of England, and of Mr. Parsons, an American. In the former, after the gun has been bored out, it has inserted from the muzzle a tube consisting of two thin wrought-iron barrels, the outer a short one shrunk on at the breech end. The end of the tube is closed by a solid wrought-iron breech-screw. The tube is held in place by a screw-locking ring at the muzzle and a screw passing through the cast-iron just forward the trunnions. In the Parsons method of conversion the tube is made of steel having a solid breech, the tube being reinforced by jackets of steel shrunk on, the whole inserted from the rear end and a plug screwed in behind it.

Shell are projectiles filled with an explosive, such as gunpowder, generally fitted with a fuse which is intended to ignite the explosive. Fuses are arranged to explode the shell on striking or else are time-fuses, whereby, by means of a slow-burning composition which is set on fire by the blast of the gun, the time of exploding can be regulated. In spherical shells for smooth-bore guns a wooden sabot or block is fastened to the shell by iron straps so that the fuse is kept to the front.

Various methods have been employed to impart rotation to projectiles. Studs on the shell projecting into the grooves of the bore, lead coating, flanged rings on the base of the projectile, and the section of both gun and projectile made hexagonal, as in the Whitworth system, have all been tried. The best practice at present gives rotation to the projectile by means of a soft copper band forced into a score near the base of the shell, projecting about .07 of an inch beyond the sides of the shell. This band is forced into the grooves of the gun as the projectile passes along the bore.

Cast-iron shell are at present being made at the Washington Gun-Factory for the new naval guns, but determined efforts are being made to manufacture cast-steel shell. Chrome-steel forgings have been found satisfactory for 6-in. shell. Abroad forged and tempered steel shells are made which pass through armor plates or rebound with but little deformation.

Besides shell, guns fire case-shot, or a collection of small projectiles enclosed in a case, the principal case-shot being grape, canister, and shrapnel. Shrapnel are thin-sided shell containing a small bursting charge of powder, around which charge are placed a number of small balls embedded in sulphur. A grape-shot is composed of a number of small shot arranged around a spindle and held in place by discs. A canister is a metallic cylinder filled with balls, closed at the ends with wooden or metallic discs. The balls are packed in rosin or coal-dust and for smooth-bores in saw-dust.

Guns were first used by the English at the battle of Werewater in 1327. In 1346 guns were used at the battle of Cressy, where, guns being unknown to the French, the English were victorious. Portable firearms are supposed to be the invention of the Italians

about 1430. It is said that the Chinese made cannon of wood wrapped with silken bands. The early British cannon were cylinders made of iron bars held in place by hoops. Next large brass cannon were made firing stone projectiles weighing as much as 1000 pounds. Such cannon were used by Mahomet II. at the siege of Constantinople in 1449. These were followed in 1490 by small guns of brass and wrought-iron throwing cast-iron balls. One of these wrought-iron guns has been recovered from the wreck of the *Mary Rose* which went down during an engagement in 1545. These guns were composed of an interior tube of wrought-iron with a weld-joint in the direction of its length hooped with a number of wrought-iron rings, of 3-in. square section, put on when hot and allowed to shrink. They were loaded by removing the breech, as shown, putting in the charge and then blocking in the breech-piece against a heavy check securely fastened to the deck. From the same vessel cast-brass guns were recovered, one containing an iron ball. Cast-iron guns were introduced about 1558. The development of the gun from this time on remained practically in a state of stagnation till the beginning of this century, the guns then being but little superior to those in use at the beginning of the seventeenth century.

The guns mounted on the vessels of the United

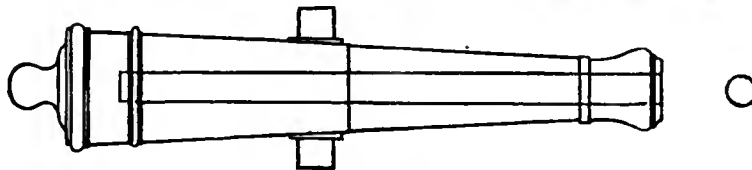

Long Gun.

States during the war of 1812 were of three different types, all smooth-bore and muzzle-loading. The long gun was very thick and with a small bore compared with what was at that time an enormous length. The

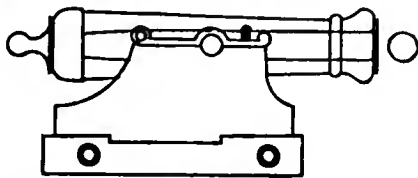

Carronade.

long guns most in use were 6-, 9-, 12-, 18- and 24-pounders. The carronade was a short, light gun with a very large bore in comparison with its weight and length, and fired a heavier ball for a much shorter distance than a long gun of the same weight. The Columbiad was a smooth-bore gun about intermediate between the carronade and the long gun. Guns of the same calibre but of different types by no means correspond in power, but roughly a long 12-, a Columbiad 18-, and a 32-pounder carronade are equivalent.

These guns were mounted in two types of vessels, one with an open or uncovered gun-deck carrying generally long bow-chasers in parts forward and carronades along the sides. The other was the frigate type, with one covered deck and one open deck above, with guns mounted on both decks. The lower or main deck generally mounted long guns; the upper deck, carronades with two long bow-chasers. These guns were well fitted and the guns' crews were well drilled, and accidents to the guns were few, though the British carronades often upset in action, due to overcharging. While we had in this war heavier and better-fitted guns, the actual construction of our guns was not so good as that of the enemy's, and there were cases of failure leading to cracked muzzles or bursting. Our shot were deficient in density and so were less in weight

for the same calibre, the difference often being as much as 7 per cent.

The practice of firing shells from smooth-bore guns is said to have been suggested by the French General Paixhans as early as 1819, and introduced into the French navy in 1824. The introduction of shell fire with its great destructive effect upon vessels led to the introduction of armor, and the race between the gun and armor was begun and is still in progress with the gun well in the lead. (See IRONCLADS.) The problems that had to be met and solved in the working of metals for guns and armor have undoubtedly had a marked influence upon the development of every kind of metal work.

About 1840 the 8-in. shell gun came into general use in the United States, where it was called the Paixhans gun. This gun, which was practically the smooth-bore muzzle-loader of that date, employed in the same gun a smaller charge with the shell than with the shot; for example the 32-pounder using 6 lb. charges with shell and 10 lb. charges with shot. Dahlgren modified the Paixhans type of gun by casting the gun of a considerably greater thickness than it retained in its final shape, and turning down the excess of metal to bring it to its proper dimensions. These guns externally are formed of fair lines without angles or projections, the thickness decreasing from the breech to the muzzle in

proportion to the pressures of the powder gases in the interior. The chamber is conical, rounded at the bottom, and the vent is inclined to the axis. Dahlgren guns were built of 9-, 10-, 11-, and 15-in. calibre, but the charges were kept very low. During the civil war the charge of the 15-in. was usually 35 lbs.,

while at present charges of 100 lbs. are fired from this gun, with a 450 lb. shot, giving a muzzle velocity of about 1600 feet per second with very moderate pressures in the bore.

Rodman about 1849 suggested casting guns hollow and cooling them from the inside, and his system was adopted for large calibres in 1859, instead of the Dahlgren system of casting solid. His idea was to produce an initial compression changing gradually to tension from the interior to the exterior.

The adoption of the Rodman system followed the trial in 1849 of two 8-in. Columbiads cast at the same time from the same iron, one being cast solid and the other on the Rodman plan. The former burst at the 85th round and the latter after 251 rounds, and in later trials of other guns 1500 rounds were withstood without bursting. There are now a number of smooth-bore Rodmans available for land service, ranging from 8 to 20 inches in calibre. The 15-in. gun, firing a projectile of 450 lbs. with 130 lbs. of powder, has a range at 20° elevation of 3½ miles, and will pierce 10 inches of iron armor at 1000 yards.

Beginning in 1841, Prof. Daniel Treadwell, of Harvard, built a number of guns, joining end to end, by welding a number of short rings or hollow cylinders. The rings were first a ring of steel about one-third the whole thickness, over which a bar of iron was wound spirally. The breech was closed by a screw plug. His guns were tested by both the army and navy, the smaller calibres with very satisfactory results.

France introduced the first heavy rifled cast-iron muzzle-loader during the Crimean war. Rifling was first developed in small-arms. Barrels were grooved at Vienna to afford lodgment for the residue produced in firing and so diminish the friction in ramming home the ball, and by accidentally making these grooves inclined it was found that increased accuracy was given. About 1850 the rifle-musket came into use as a military weapon. Breech-loading small-arms have been rapidly developed in this country, such as the guns of Colt, Hall, Sharps, Burnside, Chaynard, and Spencer.

Rifling very soon made its way from small arms to cannon. In 1846 rifled breech-loading cannon were invented by Maj. Cavalli, of the Sardinian artillery, and by Baron Wahrendorff, of Sweden.

In 1854-55 William Armstrong (*q. v.*) built a rifled steel gun hooped with wrought-iron, which was tried with most satisfactory results. In the United States the Parrott rifle was brought out about 1856, as a field-piece, and rapidly gained in favor, and was as rapidly improved till in 1862 it was the most powerful gun for weight and size in existence. The first guns of this

sorts for all calibres, the 8-in. gun was the only calibre of the converted muzzle-loaders which was adopted and manufactured for the service. Our forts were then and still remain constructed with casemates adapted to guns of about the size of the 10-in. Rodman, and the 8-in. rifles converted from these were the most economical guns that could replace them. Two hundred and ten such rifles were obtained by conversion, able to penetrate 8 inches of iron armor at 1000 yards, and these are now in service.

In the navy the xi-in. Dahlgrens were converted

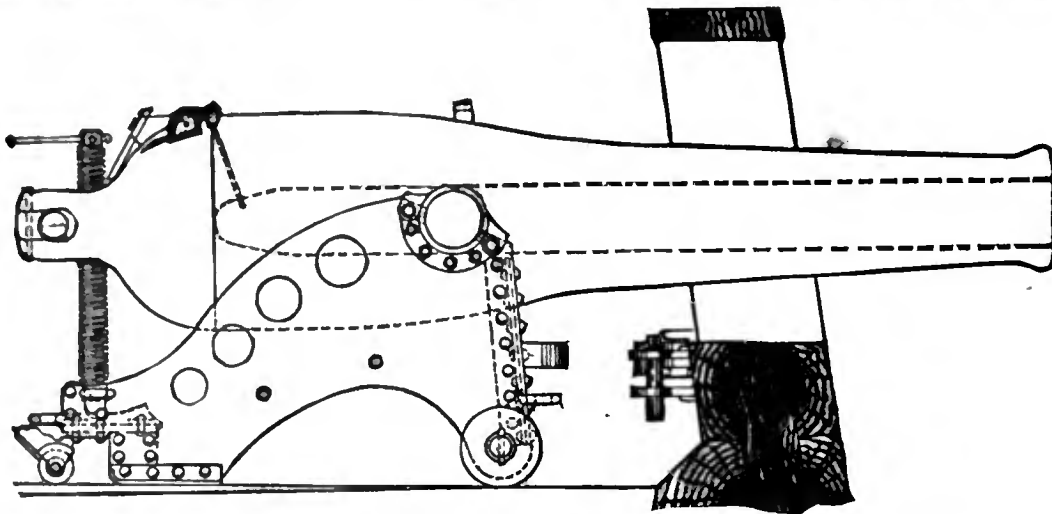

Dahlgren Shell Gun on Marsilly Carriage.

type carried into action afloat were mounted on the New Ironsides in 1862.

The Parrott rifle is a cast-iron piece, strengthened by shrinking a coiled hoop or band of wrought-iron over that part of the body which surrounds the chamber. The rifle grooves are of the plain rectangular type about $\frac{1}{16}$ of an inch deep, the twist increasing to the muzzle.

The Merrimac in the fight with the Monitor carried two 7- and two 6-in. rifles reinforced at the breech by steel rings 3 inches thick shrunk on. These were built on the design of Lieut. John M. Brook, of the Confederate navy.

Guns of this kind, cast-iron hooped with wrought-iron or steel, were the first steps in the development of the modern all-steel built-up gun, and they naturally started men to thinking as to the ways in which existing cast-guns could be improved and made to stand heavier charges, and the various systems of conversion were brought out in consequence.

into 8-in. muzzle-loading rifles on the Palliser system, and a number of 100-pounder Parrott guns were converted into 80-pounder breech-loaders by lining them with steel tubes fitted with slotted screw breech-plugs. The breech of the 100-pounder is cut off at the base ring and the hoop removed. The gun is then bored from the breech to a short distance forward the trunnions, which is as far as the tube extends. The tube is then screwed in from the rear. The band is then replaced after being lengthened from 27 to 39 inches. The rifling of the forward part of the original bore is continued into the tube. A number of 60- and 30-pounders were also obtained by conversion.

These guns now form the rifled armament of most of the wooden naval vessels in commission, as none of the high-powered guns have been fitted to the old vessels. They are fairly accurate at short ranges, but naturally could not compete with high-powered guns, and they will be retired as the vessels carrying them are condemned.

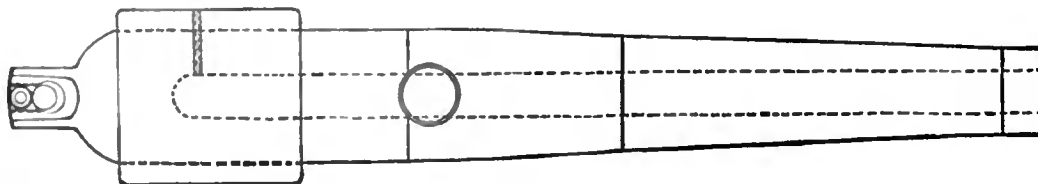

Parrott Rifle.

About 1874 the idea of converting cast-iron muzzle-loading smooth-bore guns into muzzle-loading rifles took strong possession of this country, as there were a number of smooth-bore guns afloat and ashore that were of little good as they were.

The army experimented with a number of Rodman guns converted on the Palliser and Parsons systems, and later by modifying the Palliser system to the extent of making the muzzle inserted tubes of steel, and while it may be said to have given in general satisfactory re-

sults the navy department obtained from the army in 1878 a 10-in. muzzle-loading Parrott rifle and had it converted into a 9-in. breech-loading rifle. This has been fired with satisfactory results with a powder charge of 45 lbs. powder and 250 lbs. battering shell.

About 1859 the breech-loading system began to gain in favor in England, but the breech mechanism having given trouble in several actions a prejudice sprang up against the breech-loader, and from 1863 to 1865 heavy muzzle-loaders were gradually introduced. In

1870 the admiralty decided to mount 35-ton guns in turrets. These guns were then the largest in the world. They were made only 16 ft. long and were practically failures. As it became evident that long guns with enlarged powder chambers, firing slow-burning powder, developed greater initial velocity, accuracy, and power, and that long guns gave much trouble in loading from the muzzle, with the application in France and Germany of two successful methods of closing the breech, the breech-loading system gradually gained in favor again and by 1875 began to supplant muzzle-loading. The development from this time has been most wonderful. On account of a better understanding of the working of steel, a thorough investigation of the action of the powder gases in the gun, and the development of a slow-burning powder, generating a moderate and sustained pressure, instead of the violently explosive quick-burning powder, guns can now be made twice as powerful on the same weight as in 1875. Thirty years ago the largest projectile was 68 lbs. and the largest charge 16 lbs.; to-day the largest projectile is a ton, fired with half a ton of powder. The projectiles of the largest guns weigh more now than the guns with which the battles of the last century were fought. In 1874 steel 3-in. boat-guns were designed and built by the navy; four years later a 6-in. all-steel built-up rifle, and by 1882 the navy was practically committed to the steel built-up breech-loading rifle. The army, up to this time, has not been so fortunate, as special legislation has somewhat hampered that branch of the service, they having been forced by Congress to build cast-iron guns as well as other special types that, in the light of the experience of the rest of the world, could hardly be expected to prove successful. Those having charge of a certain class of work, such as the building of guns, are naturally expected to know all that is done by others and to profit by it, and they should be the judges as to what is best. Inventors have, it is true, been in several cases forced to go to other countries for recognition and aid, but ordnance bureaus cannot carry on experiments without money, and the annoyance caused by the horde of cranks always hanging about the technical bureaus is very great, so that it is not to be wondered at that occasionally an invention having merit is passed over. It would seem that the best policy to be pursued by the government in cases where it does conclude to aid an inventor would be to require bonds for the full amount of the outlay, and all expended to be refunded in case the results are not as promised.

In England the gun now building is the all-steel built-up gun. In France the army and marine artillery are still being supplied with guns of cast-iron lined and hooped with steel tubes; but the navy has abandoned cast-iron in favor of the all-steel gun. In Germany the main supply of artillery is drawn from the works of Krupp at Essen. The guns are of steel throughout, the gun being built up with hoops and tubes. The Russian guns are all-steel and have a thin lining tube which can be easily replaced, in addition to the usual tube and hoops.

More than 25 years ago Sir Joseph Whitworth advocated the all-steel gun, built-up for large calibres, and all nations are gradually coming around to his views, and it is not likely that the built-up steel gun will be supplanted by any other, its only rival being the wire-wound gun. The wire-wound gun was invented by Dr. Woodbridge as early as 1850. A 2½-in. gun was built at the Washington Navy-Yard in 1865 and tried by the army; 1327 rounds were fired from it with no injury to the gun, though the trunnion band broke loose. A 10-in. gun was built in 1872-6. When the difficulties attending a new system of construction as this are taken into account, this gun gave most promising results, though the gun parted longitudinally after 103 rounds, the charge increasing from 40 to 90 lbs. and the projectile from 343 to 395 lbs. Both the

army and navy have wire-wound guns in hand. These guns are composed principally of steel wire wound in successive layers upon a steel tube, introducing longitudinal bars between some of the layers. In a 10-in. gun building for the army the tube is cast-iron. The steel 10-in. gun for the army weighs 22 tons and has 30 calibres length of bore. The wire-winding extends from the breech to the muzzle. The steel tube extends entirely through the gun and the breech screws into it. Longitudinal bars form a cylinder about the tube extending about one-half the length from the breech.

Guns for the army and navy are under the charge of the ordnance department of the army and the bureau of ordnance, navy department.

The Chief of Ordnance of the Army is a life-position and is at present held by Brig. Gen. S. V. Benét. The Chief of the Bureau of Ordnance of the Navy is appointed by the President and confirmed by the Senate for a term of four years. He must be a line officer of the navy of a rank not lower than that of commander, and while acting has the relative rank of a commodore, if a captain or commander. The present Chief of Bureau of Ordnance is Capt. Montgomery Sicard, U. S. N.

For many years previous to the civil war the guns of the army and navy were supplied by private firms, the principal being the West Point Foundry, Cold Spring, N. Y.; the South Boston Iron-Works, Boston, Mass.; the Fort Pitt Foundry, Pittsburg, Pa.; and the Tredegar Iron-Works, Richmond, Va. They were kept up by regular annual appropriations made for guns. The ordnance manufactured at these places was under the inspection of army and navy officers and compared more than favorably with that of the rest of the world. Upon the breaking out of the war the Tredegar works were seized by the Confederates, while other establishments than the above undertook the manufacture of guns, among them being the Reading Iron-Works, Reading, Pa.; the Builders' Iron-Foundry, Providence, R. I.; the Phoenix Iron Co., Phoenixville, Pa.; and the Ames Manufacturing Co., Chicopee, Mass.

Since the war the Fort Pitt Foundry has closed and the only private firms building guns are the West Point Foundry and the South Boston Iron-Works. At the former works a number of cast-iron smooth-bore guns were converted into rifles by inserting wrought-iron tubes, and several breech-loading rifle built-up steel guns have been assembled for the army and navy. At the South Boston Iron-Works several large cast-iron rifles and rifled mortars have been manufactured, a number of guns converted from smooth-bores to rifles, and two 8-in. and six 6-in. built-up steel rifles assembled for the navy.

The Confederate States in 1861, with the exception of the Tredegar Works, were almost destitute of appliances in the way of tools and machinery for the fabrication of ordnance; but during the war extensive works were built up, which, before the end of the war, supplied the navy and land batteries with all descriptions of ordnance. The ordnance works at Richmond supplied the armaments for the vessels in the James River, at Wilmington, and other places, as well as the carriages for the heavy navy-guns mounted in shore batteries, sending to New Orleans, alone, 22 heavy guns from May, 1861, to May, 1862. The only establishment where very heavy forging could be done was at Charlotte, N. C., and there shafts for steamers and wrought-iron projectiles were forged and finished and gun-carriages and other equipments built. At Selma there was a foundry where guns were specially manufactured for service against ironclads, supplying 47 guns for the defences of Mobile and 12 for the batteries at Charleston and Wilmington. The principal powder-mills were at Columbia, where excellent powder was made, and at New Orleans large quantities of ordnance stores, fuses, powder, and guns were manufactured.

The United States rested after the war and seemed content with converting smooth-bores into rifles, which were added to the smooth-bores already in our forts and vessels. The reports of the war and navy departments were but sorry reading for an American, and the guns upon which we relied for defence were, in other countries, already placed in museums as relics.

While we were resting others were working, and as happily our peaceful relations were not disturbed, we are in a position to profit by their experience, and if we keep out of a war for the next ten years we shall have defences suited to our national needs. The Vavasseur all-steel, built-up gun has practically been accepted as the best gun by both branches of the service, and Congress has wisely appropriated the necessary money. This step was not taken in the dark, but information of every sort bearing upon guns and gun construction was examined into. The principal sources of information were the reports of the board of the army, the gun-foundry board, composed of both army and navy officers, with Commodore Simpson as president; the fortifications board and the Senate and House committees on ordnance and warships. The gun-foundry board visited the works of noted gun-builders in Europe and presented a report of the greatest value recommending suitable sites, tools, and all apparatus for the manufacture of guns and the amounts necessary to carry their recommendations into effect. The board decided that all forged, tempered, and rough-bored and turned cast and forged material should be drawn from the private industries of the country, while the finish-boring and turning, the rifling, sighting, assembling of parts, should be done at government gun-factories, one each to be provided for the army and navy, located at the Watervliet Arsenal and the Washington Navy-Yard, respectively; large appropriations to be made for the purchase of material from the steel manufacturers, that they might be warranted in expending the large amounts necessary to buy plants for the special work required. The report of the fortification board appointed "to examine and report at what port fortifications or other defences are most urgently needed, the character and kind of defences best adapted for each with reference to armament," is most elaborate and fully covers the ground.

The whole matter was again gone into by committees of both houses, and, as an outcome of this, authority is given in the act approved Aug. 3, 1886, to use such portions as may be necessary of \$1,000,000, appropriated for armament of vessels, to manufacturing and purchasing such tools and machinery, or erecting such structures as may be required for use in the manufacture of such armament. This enabled the navy department to build up the Washington Navy-Yard as a gun-factory, and buildings have been rearranged and rebuilt, contracts made for tools and cranes, and in every way the work of construction pushed as rapidly as possible by the bureau of ordnance. When completed the Navy Gun-Factory, working ordinary time, will be able to turn out each year the following guns: 25 6-in., 4 8-in., 6 10-in., and 4 12-in., or a proportionate number of any given calibre. This yard is situated on the eastern branch of the Potomac and contains 42 acres. It is well situated as regards defence against a foreign fleet, and the sources of supply secure from destruction by an enemy. It has for several years been used exclusively as an ordnance yard, and, with meagre facilities, has turned out a number of high-powered, modern, all-steel, built-up rifles that have given results equal, and, in some cases, superior to the best guns of other nations. Carriages have been constructed for all the new cruisers recently completed and for the Miantonomoh's 10-in. turret guns. Cast-iron shells are also made here.

The navy department having the necessary appropriations, amounting to \$1,000,000, consolidated, in

the summer of 1886, in one advertisement all of its requirements for armor and gun-steel for ships of war then authorized, the steel to be of domestic manufacture, and gave an average of two years and a half in which to secure and deliver it, which covered the time necessary to procure a plant. This advertisement resulted in a contract with the Bethlehem Iron Co. under which a plant for the production of armor and gun-steel is being erected at Bethlehem, Pa. Such a result was most gratifying and a new and important industry is by this means domesticated, and we are no longer dependent upon other nations for heavy forgings for guns or armor for armored vessels. A similar policy was followed in the matter of secondary batteries of machine and rapid-fire guns, the navy department declining to make any purchases of Hotchkiss arms, unless they were manufactured in this country, and this was agreed to by the Hotchkiss company, and with the superior tools used in this country in the manufacture of arms the guns can be made and sold here as cheap as they are sold abroad to any foreign government.

The army has its principal arsenals at Watertown, Mass., at Watervliet, N. Y., and at Frankford, Pa., and small arms are made at the National Armory, Springfield, Mass. The gun-foundry board recommended that the work on the fabrication of heavy guns for the army be concentrated at the Watervliet Arsenal, and Congress has appropriated \$700,000 to carry this recommendation into effect, the expediency of making guns in government-shops having been recognized by Congress in the case of the navy. The appropriation for the gun-factory is very properly supplemented by large appropriations for gun-steel, guns, and carriages, so that the problem of supplying our forts with proper guns has been practically solved. The Watervliet Arsenal is situated at West Troy, N. Y., and comprises 109 acres. It has a river front of 1600 feet, half of which has a stone wall where vessels may unload. From the river it extends to the Erie Canal and to within 300 feet of the Delaware and Hudson River Railroad, with which an easy and inexpensive connection would afford direct communication with the Albany and Susquehanna, Rensselaer and Saratoga, Hudson River, New York Central, Troy and Boston, and Boston and Albany Railroads, affording abundant means for transportation for supplies and products, while the city of New York, 4½ hours distant by rail and 10 by water, can be drawn on for supplies of material and skilled labor of every variety. Even with the whole Atlantic coast commanded by an enemy's fleet, guns and carriages could be safely distributed to all exterior points of defence by interior roads.

The army has in its forts and arsenals:

<i>Smooth-bores</i>	1518
20-in. calibre.....	2
15-in. ".....	308
10-in. ".....	998
8-in. ".....	210
<i>Parrott rifles</i>	292
10-in. calibre, 300-pdrs.....	38
8-in. " 200- ".....	81
6.4-in. " 100- ".....	173
<i>Converted from 10-in. smooth-bores to 8-in. rifles</i>	210
<i>Smooth-bore mortars</i>	45
Total	2065

The above are all muzzle-loaders, the nine classes requiring 33 different kinds of ammunition, and are not by any means sufficient for the protection of our coasts.

A number of experimental rifles and mortars have been provided for by Congress since 1882, and these are being finished and tested as rapidly as possible, but in all likelihood the guns are not such as will be reproduced.

The fortifications board estimates that there will be required for the proper armament of our coast:

16-in. guns weighing 110 tons each.....	44
14-in. " " " 80 " "	6
12-in. " " " 50 " "	203
10-in. " " " 27 " "	222
8-in. " " " 13 " "	102
12-in. mortars.....	700
10-in. mortars.....	24

The rifled mortars have been found to give great accuracy in fire, it being possible at two miles to drop 50 per cent. of shells fired inside the horizontal area of a large ship.

Mortars were first used afloat in 1679, during the French attack on Algiers. Nelson used bomb-ships at the battle of Copenhagen, where they materially influenced the result. During the American civil war our mortar fleets performed most efficient service. In the civil war the mortars were all of the short smooth-bore variety, firing a spherical shell. A 12-in. muzzle-loading rifled mortar was built and tested by the army in 1885. A range of nearly 5 miles was obtained with 52 lbs. of powder and an elongated shell weighing 610 lbs., the elevation being 45° and the time of flight about 41 seconds. A breech-loading mortar of the same size was tried in 1887 and with 65 lbs. of powder and a 625-pound shell, the range was 5½ miles, with better results than with the muzzle-loader. The body, forming about two-thirds the entire weight, is of cast-iron, over which are shrunk two steel tubes extending from the breech to about ¾ the length. The weight is about 14½ tons.

It is proposed by the war department to place these mortars in sunken batteries, in groups of sixteen, so arranged that as many as desired can be fired in one direction, thus greatly increasing the chances of striking a vessel or other object.

The estimates of the fortifications board for the defence of 27 ports is as follows :

<i>Land defences.</i>	
Masonry and earth-works.....	\$31,863,000
Armor.....	20,300,000
Structural metal.....	3,320,000
<i>Armament.</i>	
Guns and mortars.....	28,554,000
Carriages.....	9,411,800
Floating batteries and armament.....	18,875,500
Submarine mines and adjuncts.....	4,334,000
Torpedo boats.....	9,720,000
Total.....	\$126,377,800

This with a population of 60 millions is only \$2.10 a head.

The estimated cost to defend our coasts in 1840 was \$57,000,000, or \$3.35 a head, and then the valuation of property was \$4,000,000,000; while it is now probably over \$50,000,000,000. We see that the cost now is but little more than twice the cost of defences in 1840, when the most formidable line-of-battle ship cost \$500,000, while now the corresponding ship costs \$5,000,000; ships increasing tenfold in cost, while the defences against them only increase about threefold, and the value of the property to be defended is vastly greater.

The number of serviceable naval great guns, not counting those for the new steel cruisers built and building for the navy, is :

<i>Smooth-bores.....</i>	<i>2204</i>
20-in. calibre	3
15-in. "	76
11-in. "	357
10-in. " shell.....	12
10-in. " shot.....	21
9-in. "	1011
8-in. "	346
32-pdrs. "	378
<i>Parrott muzzle-loading rifles.....</i>	<i>990</i>
150-pdrs.....	28
100- "	267

60-pdrs.....	75
30- "	375
20- "	245
<i>8-in. rifles converted from 11-in. Dahlgrens.....</i>	<i>50</i>
<i>Parrott breech-loading rifles converted.....</i>	<i>41</i>
80-pdrs.....	9
60- "	27
30- "	5
Total.....	3285

Upon the new steel cruisers, armored vessels, and monitors there will be mounted 2 12-in., 24 10-in., 14 8-in., 102 6-in., and 2 5-in. steel breech-loading rifles. These guns and the vessels carrying them are actually completed or building, and the batteries of 8 new vessels, while not yet fixed, are provided for, and also a number of pneumatic dynamite guns.

Congress, March 3, 1883, appropriated \$20,400 for the purchase and completion of 3 cast-steel 6-in. guns, one of Bessemer, one of open hearth, and one of erucible steel. Such guns were advertised for and contracts were made for cast guns of Bessemer and open-hearth steel, costing \$3300 and \$5300 respectively. These guns, rough-bored and turned, have been delivered at the Washington Navy-Yard, where they will be machine-finished and then tried. Much interest is centred in this trial, and by the advocates of cast guns much is claimed, and their success is expected to stop the manufacture of the built-up gun. Happily, however, the manufacture of built-up guns is now on so secure a basis that the much-needed defence of the country will not be delayed by having to wait till this question is settled. It is probable, however, that if guns are cast it will not be above 6-in. calibre and the material a bronze lined with a steel tube.

The powder used in the guns mounted on our older vessels and in our forts is unsuited to the high-powered modern guns. A certain amount of German brown or cocoa powder was purchased abroad by the navy department for experimental purposes, and having given excellent results it was endeavored to have it reproduced in this country, and with great success. The Messrs. Du Pont & Co. have lately submitted samples which performed satisfactorily. The successful manufacture of brown powder in this country is of the greatest importance and renders us independent of foreign manufactures in obtaining the only powder at present suitable for use in high-power guns.

The Lyman-Haskell multicharge gun is a gun designed with a number of pockets along and opening into the bore. Charges are inserted in these pockets and in rear of the projectile, and being ignited successively by the inflamed gases of the breech charge following the passage of the projectile over the opening of each powder-pocket in the bore. A 6-in. gun made on this principle was tested at Sandy Hook in 1883-4. The gun weighed 25 tons, and was of cast-iron lined with a steel tube. It had four powder-pockets, loaded by pouring in powder from the exterior, the regular chamber charge being inserted through the breech. With a powder charge of 96 lbs. and a projectile weighing 71 lbs. an initial velocity of 2101 ft. per second was obtained. The ordinary built-up steel rifle weighing about 4½ tons develops an initial velocity of over 2000 ft. per second with a 100-lb. shell fired with 50 lbs. of powder.

The naval 8-in. breech-loading rifle is shown on next page.

This gun weighs 25,720 lbs. and is 264½ inches long over all. There are in the bore 32 rifle-grooves .05 of an inch deep. The rifling begins at the junction of the bore and powder-chamber, with a twist of one turn in 180 calibres, increasing to within about a foot from the muzzle to one turn in 30 calibres, beyond which the twist is uniform. The breech-block, weighing 314 lbs., is secured in place by a slotted screw and is fitted with a modified De Bange gas-check. A muzzle velocity of 2008 feet per second has been obtained with a 250-lb. shell fired with 113 lbs. of powder.

When it was decided to have eight-inch rifles among the batteries of the Roach cruisers, there were no plants in this country able to make the necessary forgings, so they were obtained in England from Charles Cammel of Sheffield and Sir Joseph Whitworth of Manchester, but we shall not have to depend on foreign manufacturers in the future, as there are a number of steel-works now prepared to furnish such forgings as may be needed.

As a rough approximation the range of a gun is taken as one mile per each inch of calibre, but this gives results under rather than over, as during the jubilee year of Queen Victoria a jubilee shot was fired from a 9.2-inch gun, with a muzzle velocity of 2360 feet per second, and during a time of flight of 61 seconds it passed over 12.3 miles on a measured range.

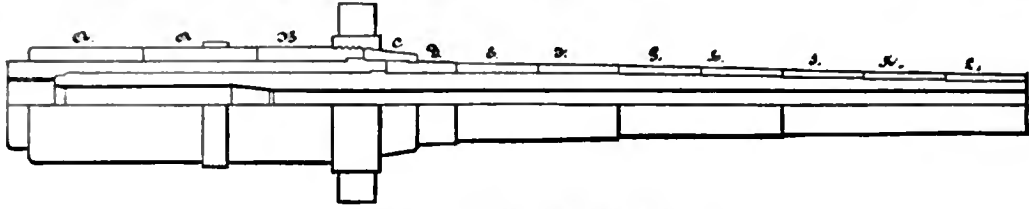

Naval 8-in. Breech-Loading Rifle.

The character of the latest guns designed for the army and navy is as follows :

Navy Guns.

Calibre.	Weight—tons.	Powder-charge—pounds.	Projectile.
5-inch		30	60
6-inch	4.80	50	100
8-inch	13.00	125	250
10-inch	26.00	250	500
12-inch	48.00	425	850
16-inch	110.00	1000	2000

Army Guns.

Calibre.	Weight—tons.	Powder-charge—pounds.	Projectile.
8-inch	13	100	290
10-inch	27	200	575
12-inch	48	350	1000
16-inch	115	800	2300

A 119-ton gun built by Krupp is said to have been fired 200 times and is still in good condition, and a gun

Gun-Carriages.—When the vast energy of a modern high-powered gun is considered, the design of a suitable gun-carriage will be seen to be a problem calling for great mathematical and mechanical judgment and application. The energy of recoil of a 100-ton gun is 60,000 foot-tons, sufficient to lift a vessel of 10,000 tons displacement six feet in the air, yet this vast energy is taken up without shock or damage to the vessel in less than five feet recoil.

The first carriages were simply fixed supports, followed very shortly by movable ones as larger charges demanded some recoil, the gun being fastened by straps or bands around the gun. Next trunnions were invented fitting in sockets on the sides of the carriage and permitting the gun to be elevated or depressed without moving the carriage, and soon trucks or wheels were put on the carriage to facilitate moving it about.

These carriages were at first made of wood and later on of iron. The Marsilly carriage is mainly used for our broadside smooth-bore guns in use now, the recoil being limited by a rope or breeching.

As the energy of recoil became greater it was necessary to allow the gun to move relatively to a fixed part of the carriage, and the carriage was made in two parts, one called the slide held against recoil by a pivot, and the other sliding on it called the carriage. Friction was set up between the carriage and the slide by means of plates on one part tightly compressed between plates on the other. As it was found that the

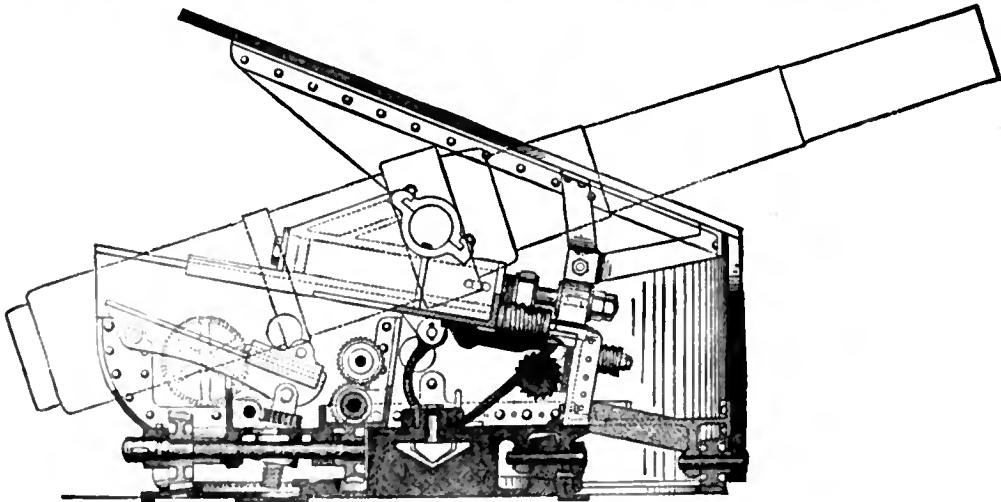

Central Pivot Carriage, 6-in. Breech-Loading Rifle.

weighing 139 tons is now building at Essen which will penetrate four feet of wrought-iron at the muzzle. Designs have been prepared at the Royal Gun-Foundry, Woolwich, for a 156-ton gun.

above method was uncertain in its action a hydraulic recoil was invented, by which a piston is fixed on one part, fitting into a cylinder on the other. On recoil the water is forced from one side of the piston to the

other through a pipe or through holes in the piston or sides of the cylinder, and the recoil gradually taken up. With large guns the piston is made in two discs, one turned by means of small projections that fit into spiral grooves in the cylinder. At the beginning of the recoil the holes in each disc coincide, but as one disc turns it gradually shuts off the holes in the other, and as the orifices are made smaller the resistance to the passage of water through them increases as the gun recoils.

The gun is run out again after recoil by power or by having the slide inclined, and the gun returns to its position before recoil by gravity. The gravity-return principle, it appears, was first used by Wahrendorff for his rifled gun.

The pneumatic carriage is an American invention by Mr. A. J. Powlett, of New York. A carriage was built for a 54-ton carriage, and tried by the army at Sandy Hook. It is a gravity-return carriage, in which the recoil was taken up by the compression of air in a cylinder which was attached to the slide, the piston being attached to the carriage. The training and elevating was done by compressed air working in pneumatic engines. The entire mechanism in this carriage is crude, and, while the results were not such as were promised, they were better than could have been expected with the carriage as it was, and were amply sufficient to warrant further trials, and the navy has contracted for an 8-in. gun-carriage, in which the recoil is to be taken up and the gun elevated, trained, and loaded by compressed air. A contract has also been made for four 10-in. gun-carriages for the monitor Terror. The entire arrangement is now different from the first carriage, and preliminary trials lately made at Sandy Hook with a small experimental car-

riage were such as to lead to the belief that the government will have developed by this contract on its completion an efficient carriage for use with guns of large calibre.

Machine-Guns.—In the invention of machine-guns and small-arms America has led the world, though in nearly all cases the inventor has had to go abroad to have his invention appreciated.

The Gatling-gun, invented by Dr. R. J. Gatling, an American, fires bullets with great rapidity. The gun most in use has 10 breech-loading barrels, each with its own lock, the barrels and locks revolving together about a common axis. The barrels are revolved by means of a crank, and as they revolve the several operations of loading, firing, and extracting the cartridge are carried on continuously. A feed-case, containing about 40 cartridges, is placed over the lock-chamber, and the cartridges fall into the proper receivers, and when it is empty another replaces it. The ordinary rate of firing is about 800 a minute. Fired with careful aiming at a target 19 ft. long and 11 ft. high, distant 1000 yards, 665 hits were made out of 1000 shots.

The Driggs-Schroeder rapid-fire gun is one of the most promising rapid-fire guns now offered. Great initial velocity, with corresponding great accuracy and penetration, is obtained with a lighter gun than with other guns of like type and calibre. Shots can be fired with the 3-pounder at the rate of 30 per minute.

The Hotchkiss revolving-cannon is also an American invention; resembling the Gatling somewhat on the exterior aspect, but differing entirely in interior mechanism, and firing a shell instead of a bullet. It consists of five barrels grouped around a common axis,

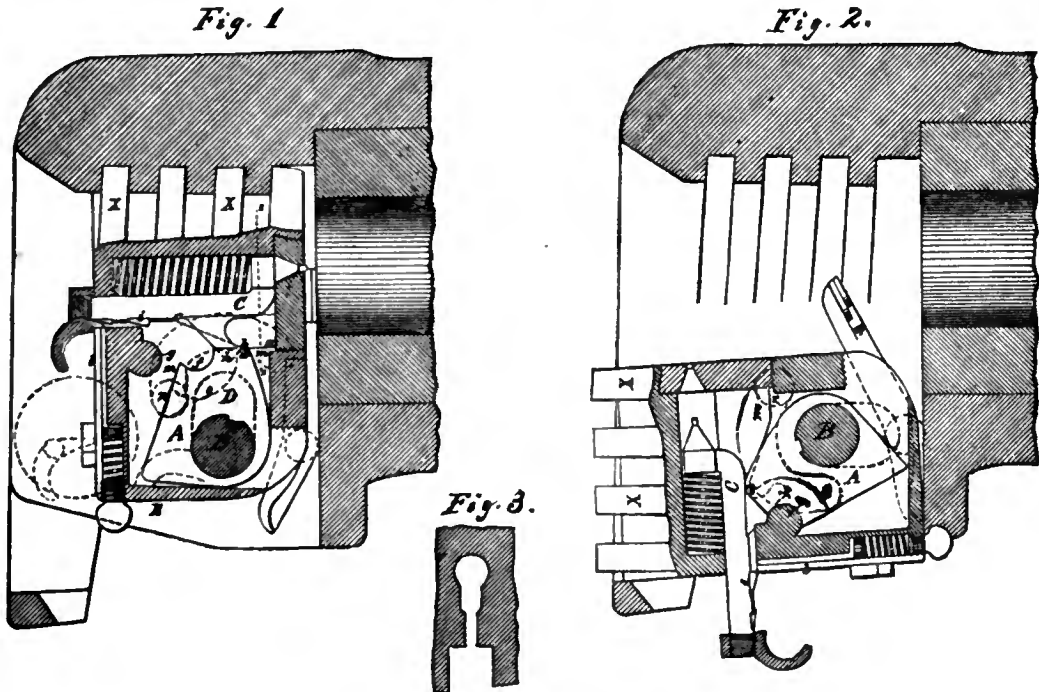

Driggs-Schroeder Rapid-Fire Gun.

The breech mechanism is shown in the accompanying cut. Fig. 3 a section through the line *zz* in Fig. 1. To open the breech, turn the bolt B to the rear, which turns the cam A, till the point *d* passes from beneath the horizontal wall *ab*, when the toe of the cam A presses against the lower portion E of the breech-block, and forces the block downwards, *d* moving along the line *bc*. While this is being done the bottom of the grooved recess E in the cam takes against a spring until the full cock-stud *i* is caught by *l*, which happens just as the shoulder *g* on the block passes into the recess *f* on the cam. The ribs *XX* are now released from the grooves in the breech, and the bolt is in the upper part of the slot D. The block can now be turned down to the position of Fig. 2, being guided by the grooves *m*, into which project guide-studs *n* fixed in the breech. There are two extractors, one on each side, for withdrawing the empty cartridge-case. The gun is fired by means of a trigger, which draws *l* down to disengage *i*, which allows the firing-pin to spring forward.

Fig. 1 showing the breech closed, Fig. 2 the breech open, and Fig. 3 a section through the line *zz* in Fig. 1. To open the breech, turn the bolt B to the rear, which turns the cam A, till the point *d* passes from beneath the horizontal wall *ab*, when the toe of the cam A presses against the lower portion E of the breech-block, and forces the block downwards, *d* moving along the line *bc*. While this is being done the bottom of the grooved recess E in the cam takes against a spring until the full cock-stud *i* is caught by *l*, which happens just as the shoulder *g* on the block passes into the recess *f* on the cam. The ribs *XX* are now released from the grooves in the breech, and the bolt is in the upper part of the slot D. The block can now be turned down to the position of Fig. 2, being guided by the grooves *m*, into which project guide-studs *n* fixed in the breech. There are two extractors, one on each side, for withdrawing the empty cartridge-case. The gun is fired by means of a trigger, which draws *l* down to disengage *i*, which allows the firing-pin to spring forward.

which are revolved in front of a solid fixed breech-block. This block has an opening through which the cartridges are introduced, and another through which the cases are extracted. An important feature is, that at the instant of firing the barrels are still, and the mechanism is such that the loading, firing, and extracting take place during this pause. A cartridge is placed in the feeding-trough, which a piston pushes into a barrel; the barrel then begins to revolve, and the cartridge is carried on till it arrives before the firing-pin, which extends into the solid part of the breech, and which has been drawn back against a spring by means of a cam. When the cartridge is in the proper position the barrel ceases to revolve, the cartridge is struck by the firing-pin and discharged; then the revolution begins again, and the empty cartridge-shell is carried on till it comes to the extractor; another cartridge is by this time in the firing position, the barrels again cease to revolve, and the empty shell is withdrawn and dropped to the ground.

Shots from the gun firing a shell weighing 1 lb. will penetrate the sides of a torpedo-boat at the distance of $1\frac{1}{2}$ mile, and they can be delivered with great accuracy and rapidity.

Besides the revolving-cannon there are Hotchkiss rapid-firing guns, having one barrel only, wherein the cartridge is placed and fired by a trigger. This gun is of recent development, the United States being the first to order guns of this kind, the ones ordered being 6-pounders, 3-pounders, and 1-pounders, for the Boston, Atlanta, and Dolphin. The great advantage of having the charge, projectile, and firing-fulminate all in one case, so that the loading is all done at once, is so evident that there has sprung up a demand for large calibres, and the Hotchkiss company have extended the use of this fixed ammunition, as it is called, to 9-, 14-, and 33-pounders. These will penetrate at the muzzle 5.5, 6.7, 9.5 inches of wrought-iron respectively.

Another remarkable American invention is the Maxim automatic machine gun, which is loaded and fired by the energy of recoil of a preceding shot, loading and firing itself in fact after once being started, leaving the aiming only to be done. Smoke is consumed and the report muffled. The cartridges are placed side by side in a belt, and are fed into the gun by a bell-crank lever, one arm attached to the barrel and the other to a slide having two clutches projecting downwards. On recoil the clutches move to the right and engage a fresh cartridge, and the return of the barrel moves the cartridge into a position to be seized by a carrier. The first round is fired by hand, the gun recoiling opens the breech, withdraws a loaded cartridge from the belt, extracts the empty shell, cocks the hammers, compresses a spring which, when the recoil is at an end, forces the barrels back into the firing position, the return of the barrel expelling the empty case, pushing the loaded cartridge into the breech, closing the breech and pulling the trigger. This is truly a wonderful piece of mechanism, and the inventor is sanguine as to being able to apply the principle to large calibres.

The Maxim-gun has been built of a size to fire rifle-balls up to a 3-lb. shell.

The rifle-calibre gun is shown in Plate XL.

The outside of the gun is shown in Fig. 1, the fixed parts in firing are shown in full lines, excepting the crank A C B. The crank is part of the recoil system, the arm A coming into violent contact with the stationary arm D on firing. A by its shape moving up on D with a gradually increasing arc motion through about 150° , the most rapid motion being when the toe of the arm D bears against the lower part of A, the rotary motion being stopped by the arm B taking against the spring-buffer E. The spiral-spring F, shown dotted, is in a box on the left of the gun-casing. The spring is extended one inch by the recoil, and the chain G is wound up a little at its after end by the revolution of the shaft, still further extending the

spring. When the handle B is stopped by E the spring tends to bring all parts back to the firing position, the part H, which stops the crank-handle, being so made as to stop all rebound.

I shows the sights, K the feed-box, L the trigger.

A central longitudinal section is shown in Fig. 2, the parts being in the firing position.

The lock consists of a firing-pin *a*, a main-spring *b*, a hammer *c*, and a catch *e*, all mounted in the detachable belt N N N. When the trigger L is pulled the rod O is drawn back, and with it the lower end of the catch *e*, this movement of the catch releasing the hammer, the main-spring throwing the firing-pin forward, striking the cartridge and exploding it. Fig. 3 shows the parts when the breech is closed, Fig. 4 the parts when at the end of recoil. Figs. 5 and 6 are sections corresponding to the outside views of Figs. 3 and 4, and Fig. 7 is a perspective view corresponding to Fig. 4.

The limit of recoil of the barrel is one inch, but at the beginning of recoil the shaft C and the crank R begin to rotate, and all other movable parts are thus drawn away from the barrel. The sliding-piece T has an undercut groove on its forward face which fits the head of a cartridge, and in this way serves the double purpose of a breech-closure and a carrier to transfer cartridges from the belt to the gun. As it moves away from the barrel it withdraws the empty cartridge-case from the bore and a loaded cartridge from the belt, and, as its motion to the rear continues, it passes from the guides that sustain it and drops, partly by gravity and partly by means of a spring, into such a position as to bring the loaded cartridge into line with the barrel and the empty case into line with the discharge-tube P. The hammer is cocked through the motion of the crank R bringing the connecting-rod S in contact with the hammer-extension *S*. The spring brings all parts back into the firing position, as shown in Fig. 3. The empty and full cartridges are pushed into the proper places, the carrier is lifted by the arm U and the bell-crank V, the bell-crank being of such shape that the lifting takes place after the cartridge has been thrust home, while the movement of the connecting-rod releases the safety-catch *f*. Now if the pressure be continued on the lever *g* the gun will again fire, and continue to do so as long as the pressure lasts and the ammunition is supplied.

A safety-catch is fitted, which, when turned out as in Fig. 2, makes it impossible to pull the trigger.

The cartridges, which are placed in a belt, are fed into the gun by a bell-crank lever, one end fastened to the barrel and the other to a slide having two fingers extending downwards. When the barrel recoils these fingers move to the right and take hold of a cartridge, and, on the return of the barrel, move the cartridge so that it can be taken by the carrier.

At a recent official trial conducted by the Austrian government an average rapidity of 600 rounds per minute was obtained, while the gun was being pointed in every direction permitted by the mounting. In all, 13,504 rounds were fired, and the gun behaved remarkably well, the loading and firing mechanisms working faultlessly. The barrel is surrounded by a water-jacket, to keep down the heat, holding water sufficient for the firing of 1000 rounds in rapid succession. The water can be at any time renewed in 20 seconds.

Mr. Maxim has built a rapid-firing gun wherein the loading only must be done by hand. When fired, the barrel recoils through a distance of 4 inches, the breech remaining closed. The return to the firing position drops the breech-lock, cocks the hammer, and extracts the empty case. The insertion of the cartridge brings into operation a mechanism for closing the breech. Mr. Maxim has patented also a dynamite gun in which an explosive mixture is used to expel the projectile. The projectile is first started by a mixture of air and a volatile hydrocarbon under pressure, and when the projectile has passed over a little more than one-quarter

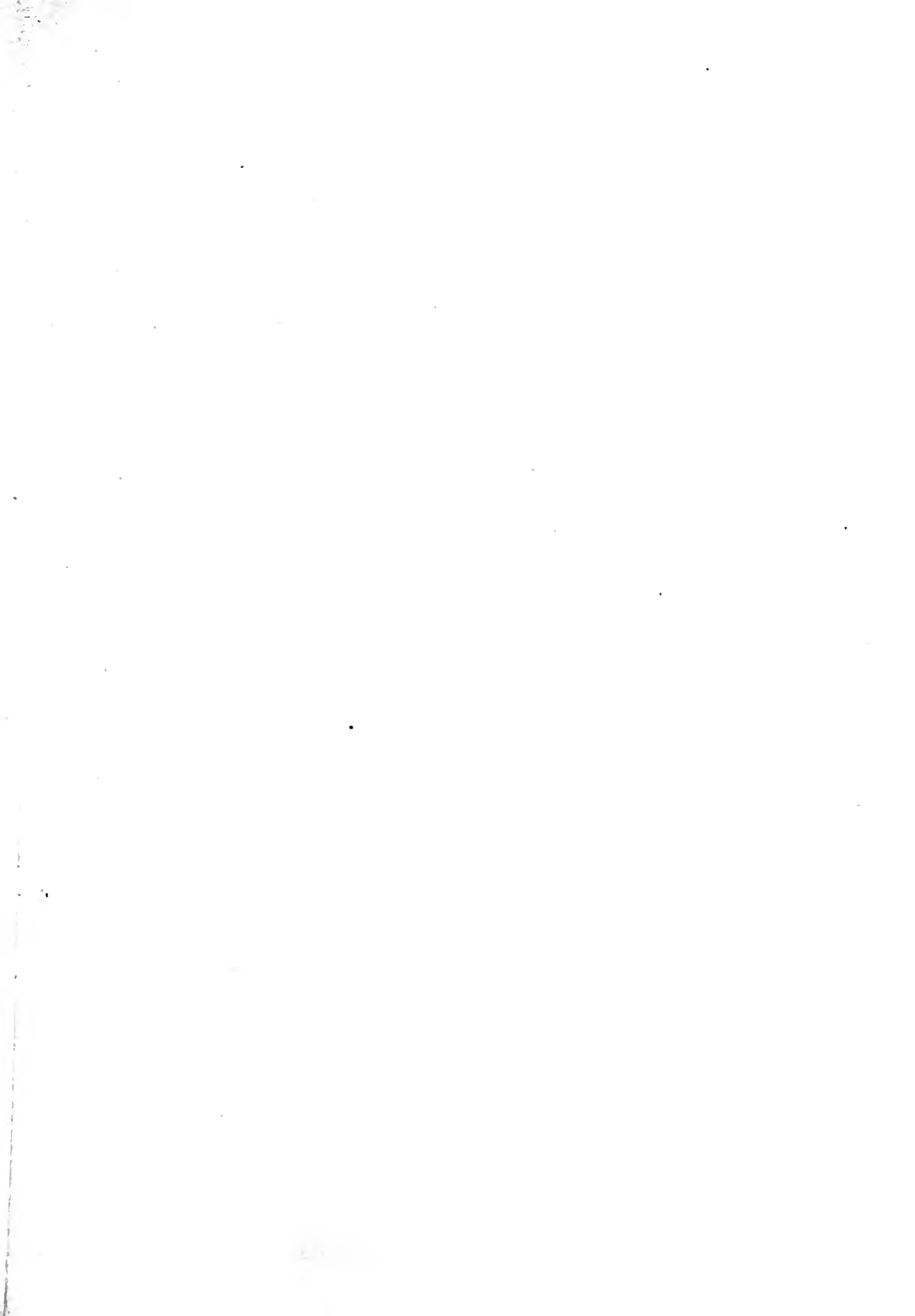

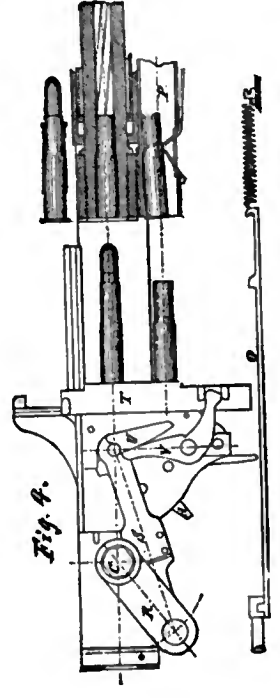
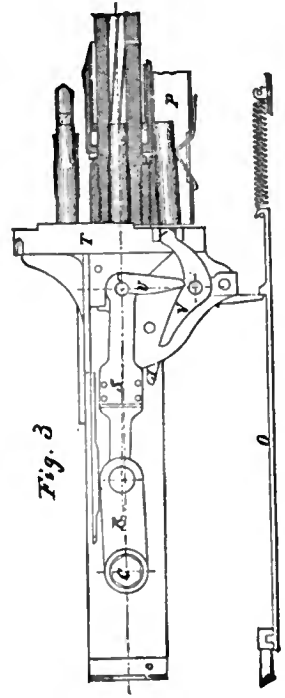
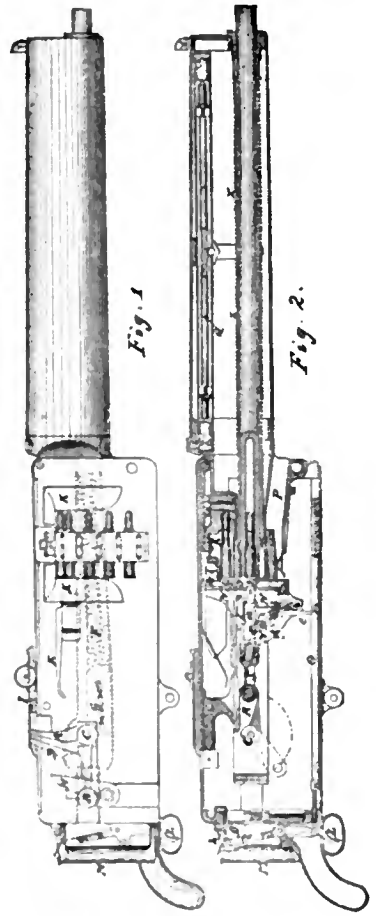
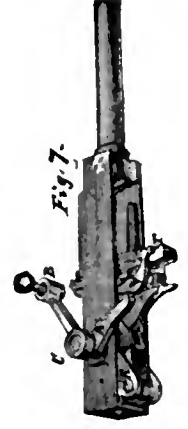
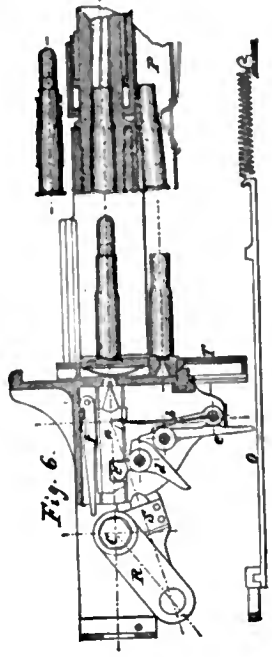
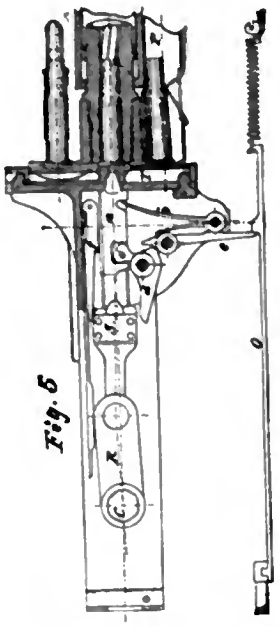

the length of the bore a detonating cartridge is exploded, exploding in turn the mixture of gases, increasing the pressure about eight times.

The pneumatic torpedo-gun, firing dynamite shells by using compressed air instead of gunpowder, invented by Capt. E. L. Zalinski, Fifth artillery, U. S. A., bids fair to take a most important place in future warfare. This gun is subject to much adverse criticism, and because termed a gun it seems to be the impression that this weapon should at once demonstrate its power to take the place of all other guns. This it cannot do; it has its own place, and that a most important one. Its fire is more accurate than that of the mortar and the destructive effect of the shell superior to that of the torpedo. The torpedo can hardly be considered efficient at more than 350 yards, while this gun throws charges 2 miles.

A 2-in. gun was first built and, giving satisfaction, a 4-in. gun was built in the spring of 1884 and tried in December of the same year, showing conclusively that shells containing high explosives could be thrown with safety upwards of 2000 yards. In August, 1885, an 8-in. pneumatic gun was completed and mounted at Fort Lafayette. This gun has been fired a number of times with satisfactory results. Six shots were fired Sept. 20, 1887, at a government schooner called the Silliman, resulting in the total destruction of the vessel,

drawn from those to restore the pressure in the firing reservoir. Compressed air is furnished by means of some standard air compressor, the Norwalk machine having been used so far. The shell is made of seamless brass as light as is consistent with strength. It is kept in the proper trajectory by means of a tail tube to which are attached spiral vanes, and it is centred in the bore and kept from metallic contact with the same by means of pins in the head, by a leather gas-check at the rear end of the cylindrical part, and by projections rivetted to the spiral vanes of the tail. The conical point is made strong enough to resist crushing from impact with the water, but so thin as to readily crush when striking a solid target. The charge in the shell is uncamphorated explosive gelatine with a core of dynamite. Handled as carefully as gunpowder, there is practically no more danger of accidental explosion.

A very ingenious electric fuse is fitted to the shell, so arranged as to explode after striking a target or descending below the water, a current being started by wetting the elements of a battery carried in the shell. The dynamite cruiser Vesuvius will carry three of these guns, of 15-in. calibre, placed abreast and parallel at a fixed angle. They are about 55 ft. long and will throw shells containing 600 lbs. of explosive gelatine to a distance of a mile. Thirty charges are carried. The guns can be loaded by hydraulic machinery

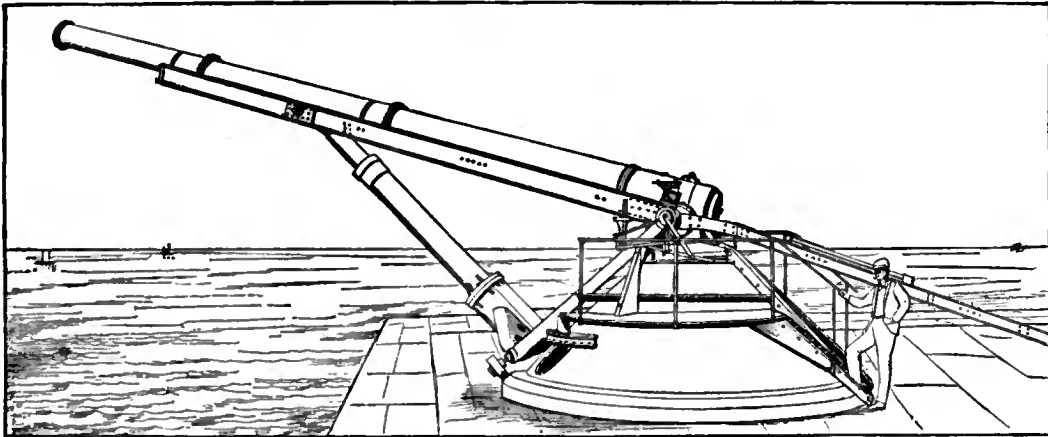

Fifteen-Inch Dynamite Gun.

four shells landing in practically the same spot at a range of 1613 yards. Three 15-in. guns are now completing for the dynamite cruiser Vesuvius, and a 15-in. gun for the Italian government.

The gun-barrel consists of a long tube of brass or other metal. The breech mechanism is a simple gate arranged so that the valve mechanism cannot work till the breech is properly closed.

A complete and accurate control of the range is obtained by regulating the amount of compressed air admitted in rear of the projectile, and without a change on the elevation or pressure. The valve admitting air is a balanced valve whose opening and closing is regulated, and in addition to this the air can be throttled on its way from the reservoir to the valve, so that though the valve may open and close in a uniform time, the amount of air passing into the gun in that time can be varied. As this can be regulated to a hair's breadth with great rapidity, the range can be better regulated for a moving target than by changing the elevation of the gun.

The compressed air is contained in wrought-iron reservoirs from 12 to 16 in. in diameter and about 18 ft. long. The reservoir tubes from which the air is drawn directly for firing are called the firing reservoirs. When a large number of rounds are required to be fired with great rapidity an auxiliary storage reservoir is used, charged with air compressed to twice the pressure to be used in the gun. After each discharge the air is

as rapidly as twice a minute. The vessel has twin screws and will develop a speed of 21 knots, or about 25 miles an hour.

In the preparation of this article the following publications have been freely used: *The Development of Armor*, by E. W. Verrey; the Publications of the Intelligence Office of the Navy; the *Reports of the Fortifications Board*, and of the Chiefs of Ordnance of the Army and Navy; Roosevelt's *Naval War of 1812*; Scharf's *History of the Confederate States Navy*. [L. N.]

OREGON, one of the Pacific States, occupies but

See Vol. XVII. a small portion of the territory once included under its name. It then denoted all the land north of 42° N. lat. and between the Rocky Mountains and the Pacific Ocean. The word is said to occur first in Capt. Jonathan Carver's *Travels through the Interior Parts of North America* (1778), where it denotes a large river which the Indians of the upper Mississippi mention. The Missouri was probably intended, but Bryant in his *Thanatopsis* (1818) applied it to the river to which its discoverer, Capt. Robert Gray, had given the name of his ship Colum-



bia in 1792. John Jacob Astor in 1811 established a fur-trading station at Astoria on this river, but the post was sold in 1813 to the North-western Fur Company. Actual settlement by New Englanders began in 1832, and a Methodist mission to the Indians was planted in 1834 at Salem.

Great Britain however put forth claims to the "Oregon country" and the U. S. Government was remiss in repelling them until Dr. Marcus Whitman, a zealous Presbyterian missionary and promoter of immigration, crossed the mountains in the winter of 1842-43, and proved to the authorities at Washington the true value of the territory which they had almost allowed to pass under foreign control. The Oregon question was a prominent factor in the presidential contest of 1844, the Democratic party insisting on extending the claim of the United States as far north as 54° 40' N. lat. President Polk's administration, however, compromised with the British government on the extension of the boundary of 49° N. lat. to the Pacific. After the acquisition of California by the Mexican war, Oregon Territory was organized in 1848. Its limits were reduced in 1853, and in 1859 it was admitted as a State.

Population.—Oregon at its admission to the Union had a population of about 50,000. The State census of 1885 gave it a population of 201,051, not counting 4220 Chinese. In this census the population of Baker county is estimated at 7000, the records of the actual enumeration having been destroyed by the burning of its court-house. The State has received a new impetus since the completion of the Northern Pacific Railroad in 1883. Three new counties have been organized, Malheur, Morrow, and Wallowa.

Finances.—The gross value of the property in the State in 1887 was \$120,635,706. The State tax-rate for general purposes is 49 cents on each \$100, for militia 2 cents, and for the State University 1 cent. The estimated expenditures for 1888 were \$482,709, against which there was a balance in the treasury of \$71,755.

Education.—The school age in Oregon is from 4 to 20 years. The following table gives the educational statistics of 1887:

	Males.	Females.	Total.
Persons of school-age.....	44,691	42,526	87,217
Enrolled in public schools.....	27,183	25,842	53,025
Average attendance.....	18,973	18,433	37,406
Teachers.....	919	1,170	2,089
Average monthly pay.....	\$45.78	\$34.79	
School-houses.....			1,324
Enrolled in private schools....	2,505	2,429	4,934

In 1887 the public school system was extended to include the Kindergarten. The receipts from the school funds were \$669,935. The irreducible school-fund was \$1,059,409. There are in the State 8 colleges with 44 instructors and 809 students. The State University at Eugene City has 184 students enrolled with an average attendance of 110. It has over 40,000 acres of public lands, and an endowment of \$126,000, and the Legislature makes an annual appropriation of \$5000. In 1887 its expenses were \$18,285 and the income \$21,511. The State Agricultural College at Corvallis was founded in 1870 by the Methodist Conference but received some support from the State. The Conference in 1886 transferred the property to the State, and the Legislature accepted it on condition that the friends of the institution erect suitable buildings. The corner-stone was laid in August, 1887, but the Conference of that year endeavored to recall the gift. This college had 5 instructors and 52 students, the annual expenditure being \$8470. It has 90,000 acres from the grant of the U. S. Government, and its fund in 1887 was \$99,015. There are normal-schools at Ashland, Monmouth, Drain, and Weston. Among the other educational institutions are 40 academies, a school for the blind, and one for the deaf and dumb.

The Penitentiary in September, 1887, had 267 convicts, being less than the average number. Of these

165 were engaged in foundry-work by contract, and 30 in brick-making. Their labor pays half the cost of their maintenance. The expenses for two years were \$57,172, and the receipts \$36,063. The Insane Asylum at Salem, built in 1881-83, half a mile from the penitentiary, cost \$144,000.

Railroads.—The Oregon and California Railway extends from Portland southward, passing through the Willamette Valley. It has a branch line from Albany to Lebanon. Its west side division runs to Corvallis; its east side division is leased to the Southern Pacific Railroad.

The Oregon Railway and Navigation Company extends from Portland to Huntington, on the eastern border of the State, 404 miles. It then joins the Oregon Short Line, which connects with the Union Pacific Railroad, to which company the whole is leased. The company has authorized the construction of 1300 miles of branch roads.

The Northern Pacific Railroad reaches Portland by a ferry at Kalama. Besides the foregoing through lines to the east and south, Portland has a narrow gauge road 80 miles long on the west side of the Willamette river, with some short branches.

Legislation.—At the election in June, 1884, the proposed constitutional amendment conferring the right of suffrage on women was rejected by a vote of 28,176 against 11,223. At the election in November, 1887, an amendment prohibiting the sale of liquor was submitted to the popular vote and defeated, there being 19,973 votes for it and 27,958 against it. At the same time the amendment to change the date of the State election, and another giving the Legislature power to fix the salaries, which are now prescribed by the Constitution, were both defeated. The registry-law for voters has been pronounced unconstitutional by the Supreme Court. In 1887 the Legislature set apart the first Saturday in June as Labor-day. It also strictly prohibited the sale or gift of opium, chloral, or cocaine except by physicians and druggists for cure of diseases. A State Board of Agriculture was appointed in 1885, and a State Fish Commission, State Railroad Commission, and Stock Inspector were appointed in 1887.

Statistics.—In 1885 there were by the State census 1,243,904 acres under cultivation; 373,247 cattle; 165,909 horses; 3591 mules; 202,612 hogs; 1,636,929 sheep. In 1887 the State Board of Agriculture reported the sheep at 2,593,029.

The State census of 1885 gave the following amount of agricultural produce: wheat, 8,933,718 bus.; oats, 6,247,300 bus.; barley and rye, 1,694,614 bus.; hay, 377,822 tons; corn, 273,497 bus.; butter and cheese, 3,287,923 lbs.; flaxseed, 14,262 bus.; tobacco, 13,207 lbs.; hops, 2,547,378 lbs.; potatoes, 2,650,284 bus.; wool, 9,165,830 lbs.; apples, 2,005,373 bus.; plums and prunes, 150,306 bus. There were 169,135,726 ft. of lumber cut in that year.

The mineral products for the year 1885 were 29,600 tons of coal, and 14,965 oz. of gold; the latter is probably less than the actual amount obtained, as many miners do not report.

The county reports to the secretary of state in 1887 gave the following statistics. There are altogether 5,874,668 acres of land, valued at \$34,091,141. The horses and mules are valued at \$6,185,037; cattle, \$6,059,134; sheep, \$2,504,888; swine, \$184,187.

The salmon fishery is one of the most important interests of Oregon. Its growth is seen in the following table:

Year.	Boats.	Cases.	Price.
1866.....	2	4,000	\$16.00
1870.....	50	150,000	9.00
1875.....	300	375,000	5.60
1880.....	900	530,000	4.80
1883.....	1700	629,000	4.80
1884.....	1700	629,000	4.60
1885.....	1600	553,800	5.00
1886.....	1500	448,500	5.30
1887.....	1400	379,000	5.96

The fishery is thus seen to have reached its height in 1883 and to have since declined. The State Fish Commission is expected to devise restrictions against the excessive capture of fish, which threatens to destroy the business.

For further information see *Resources of the State of Oregon*, prepared by the State Board of Agriculture and published by the State (Salem, 1888). (J. C. M.)

O'REILLY, JOHN BOYLE, poet and journalist, was born at Dowth Castle, county Meath, Ireland, in 1844. He became a reporter for English papers, but in 1863 enlisted in the Tenth Hussars, for the purpose of propagating Fenianism. He was detected, convicted, and sentenced to penal servitude for twenty years. After spending some time in English prisons he was, in 1867, banished to Western Australia. From this land of exile, in 1869, he departed at night in an open boat with a single companion without food or drink. After three days' exposure to the perils of the sea he was taken aboard an American whaler. He was carried to Liverpool, and thence quickly made his way to the United States. In 1870 he became connected with the *Boston Pilot*, of which he is now editor. He has published *Songs of the Isles*, *Moondyne*, and other books.

ORELLANA, FRANCISCO (c. 1500-1549), a Spanish explorer, was born at Truxillo about 1500. He took part in the conquest of Peru in 1531, and in 1540 was second in command of Gonzalo Pizarro's expedition to the east of the Andes. While descending the Napo, their provisions became exhausted, and Pizarro sent Orellana with 50 men in a brigantine down the river to procure a supply. Orellana reached the Amazon in three days. Finding the country entirely different from what he expected, and judging the return too difficult, he determined to sail down the main stream. In seven months he reached the mouth, having frequently been attacked by the natives. On returning to Spain in 1541 he told of a country inhabited by women warriors. Obtaining a commission to conquer and colonize El Dorado he organized an expedition, which proved very unfortunate. After entering the Amazon he died of a fever.

ORELLI, JOHANN KASPAR (1787-1849), a Swiss philologist, was born at Zurich, Feb. 13, 1787. He graduated at the university of that city and studied theology. While pastor at Bergamo he preached in German, French, and Italian. In 1813 he became a teacher of classics at Coire, and in 1819 was made professor of hermeneutics and rhetoric at Zurich. He died there Jan. 6, 1849. His editions of Cicero, Horace, and Tacitus are of special merit. He published also *Onomasticon Tullianum* (3 vols., 1836-38), and *Inscriptionum Latinarum Selecturarum Collectio* (2 vols., 1828).

ORGAN. This article is confined to organ-building in America. The art of organ-building in this country was until recent years in a rather crude state. Wm. M. Goodrich (1777-1833) was the first

native organ-builder worthy of the name, although others were engaged in the business before him. The organ made by Edward Bromfield in Boston in 1745 was the first one built in this country. Thomas Johnston was also making organs in Boston soon after, and he was succeeded by Josiah Leavitt. Henry Pratt built a number of organs during the early part of this century. During this period, however, foreign organs, of which the importation had begun as early as 1713, were still in demand.

Goodrich came to Boston in 1799, and there followed his business until his death. He built his first organ in 1805, and had such success that, notwithstanding the existing prejudice against American work, but few organs were imported during this time. His brother Ebenezer, after working with him for some time, set up on his own account. Thomas Appleton, who entered William Goodrich's employ in 1807, subsequently also went into business for himself, first in part-

nership with Messrs. Hoyt and Babcock, and later alone. A little before 1830 the art of organ-building began to receive a new impulse. The brothers, Elias and George G. Hook, began business in Boston about this time, and soon took a prominent position among American manufacturers. In 1853 Wm. Nutting, Jr., established himself at Bellows Falls, Vt., and at the same time there were four large factories in Boston—Appleton's, Simmons', Hook's, and Stevens'. Up to this time, however, but few attempts had been made to improve either tone or mechanism of the organ. It was the interest excited by the erection of the excellent organ in the Music Hall, Boston, that did much to bring about a complete change of affairs. This large instrument, built by E. F. Walcker & Son, of Ludwigsburg, Württemberg, was begun in 1857 and finished in 1863. The American builders, having once recognized the necessity of producing better work, soon began to introduce many and important improvements, and it was not long before they could compete successfully with the European manufacturers.

Two of the best-known houses to-day are those of Roosevelt and Jardine, both of New York. Hilborne Lewis Roosevelt (1849-1886) began business in New York in 1872. He made some notable improvements in the art of organ-building. By his construction of the wind-chest each pipe has its own valve, actuated by compressed air. The "automatic adjustable combination" enables the player to place any required combination of stops under immediate control, and to alter such combination as frequently as desired. The electric action was first employed by Roosevelt in 1869, when he was with Hall & Labagh, of New York, and has subsequently been frequently employed. His brother Frank succeeded him in 1887. Among the numerous instruments built by this firm are those in Grace Church, New York (1878); Chickering Hall, New York; Cathedral of the Incarnation, Garden City, L. I. (1879-83), 106 stops; St. Thomas' Church, New York (1881-3), 56 stops; Church of the Incarnation, New York (1883), 50 stops; First Congregational Church, Great Barrington, Mass. (1883), 60 stops; Calvary Church, New York (1887); and the organ built for the United States Centennial Exhibition, now owned by the Massachusetts Charitable Mechanics' Association.

Mr. George Jardine (1801-1883), the founder of the house of George Jardine & Son, established himself in New York as early as 1836. He introduced various improvements, among which are the "pneumatic vacuum pallets." In 1860 he took his son Edward G. into partnership. This firm has also built a large number of instruments, notably those in the New York Cathedral (60 stops); St. George's Church, New York (80 stops); Brooklyn Tabernacle (70 stops); St. Agnes Church, Brooklyn (70 stops); Pittsburg Cathedral; Trinity Church, San Francisco; Mobile Cathedral; and Christ Church, New Orleans.

The firm of Hook & Hastings was founded by the brothers Hook in 1827. Mr. F. H. Hastings first engaged with them in 1855, became a partner in 1865, and now succeeds them. The principal instruments that have come from this factory are the organ in the Cathedral of the Holy Cross, Boston (1875), with 3 manuals and 83 stops; that in the Music Hall, Cincinnati (1878), 4 manuals, 96 stops; and that in Tremont Temple, Boston (1880), 4 manuals, 65 stops. Another well-known Boston firm is that of Hutchings, Plaisted & Co. It was founded in 1869 by J. H. Wilcox, George S. Hutchings, Mark H. Plaisted, and G. V. Nordstrom, all of whom had been previously connected with Hook & Hastings. The firm-name was at first "J. H. Wilcox & Co.," which, in 1872, was changed for the present name. These builders have erected organs for Christ Church, Baltimore, Md.; St. Peter's Church, Philadelphia; Old South Church, Boston; Church of Immaculate Conception, Lowell, Mass.; and numerous others. Other notable

organs in this country are those in St. Bartholomew's, New York, by J. H. & C. S. Odell; and Temple Emanuel, New York, by Hall & Labagh. Mention should also be made of the large organ in the Roman Catholic Cathedral at Montreal, the work of Samuel Russell Warren (1809-82) of that city, who formerly worked in Boston.

As in other arts, so too in that of organ-building, America has made great strides in advance, and in the production of such excellent instruments as those mentioned, our native builders have shown their ability to compete successfully with the best foreign manufacturers. (F. t. w.)

ORGAN, REED. It appears that instruments in which "free reeds" were used were made in this country quite early in the present century. Aaron Merrill Peasley, in 1818, obtained a patent for reed instruments; this patent is now in the possession of the Mason & Hamlin Organ and Piano Co. J. H. Bazin, of Canton, Mass., is also named as an inventor in this connection. The instruments manufactured at this time were, of course, imperfect and defective in construction. The earliest forms of an organ with free reeds and without pipes, the bellows being worked by the foot, were the "scraphine" and the "melodeon." The latter was first introduced about 1840, and two of the best-known firms engaged in its manufacture were those of Carhart & Needham, and George A. Prince & Co., both of Buffalo, N. Y. One form of this instrument, the harmonium, appears to have been invented by Debain of Paris, and improved by Alexandre, whose name it bore in this country. Until the introduction of the perfected reed organ, in 1861, the melodeon was very popular in this country, despite its faults, and, amongst others, the firm of Geo. Prince & Co., which dissolved in 1875, manufactured many thousands of these instruments. Jeremiah Carhart, about 1836, made several improvements, notably the plan of acting on the reeds by suction instead of blowing, which Peasley had spoken of in his patent. This is a characteristic feature of the American organ, the foreign instruments being still worked by force bellows. Carhart's partner, E. P. Needham, also made some improvements. But the most important improvement, and the one which has contributed greatly to the present perfection of these instruments, and their consequent popularity, was the discovery that by twisting and bending the reeds in various ways the quality of tone was greatly modified and improved. This discovery was made in 1848 by Emmons Hamlin, then a workman in the factory of Prince & Co. In 1854 he and Henry Mason, a son of Lowell Mason, began the business of the firm which in 1868 took the name of the Mason & Hamlin Organ Co. Under the inventor's eye this newly-discovered art of "voicing reeds" was carried to great perfection. In 1861 the firm first introduced the American cabinet or parlör organ in its present form. The excellent instruments produced by the firm have placed it in the foremost rank of American reed organ manufactures. The factories of the firm are located at Cambridgeport, Mass., and the home office in Boston, with branch offices in other cities, and agencies all over the world. The name in 1882 was changed to the Mason & Hamlin Piano and Organ Co. Another well-known firm is that of Jacob Estey & Co., Brattleboro, Vt. The business was begun in 1846, by two gentlemen, in a building owned by Jacob Estey. In 1852 the concern passed into the hands of Mr. Estey. The instruments of this firm are also well known in this country and abroad, and rank among the best. The firm of Wilcox & White, of Meriden, Conn., was formed in 1876. The business grew rapidly, and their organs are now favorably known the world over. Numerous other manufacturers are also engaged in this business in the United States. The many improvements which have been applied by American makers have resulted in producing an instrument

which is extensively used in foreign countries as well as in the United States. These organs are made in all styles and sizes, some of them even with two or three manuals, being then almost equal to small pipe organs in power and resource. The popularity which the instrument has attained through the improvements introduced is very great, and it has been estimated that there are now more than 80,000 cabinet or parlör organs, under various names, made and sold yearly in the United States alone, by about 250 makers.

(F. L. W.)

ORIOLE. The so-called orioles of America are, as is agreed by all systematists, of a family (*Icteridae*) quite distinct from the orioles of the Eastern Hemisphere. Our orioles are briefly noticed in the *ENCYCLOPÆDIA BRITANNICA* under the name *Icterus*. The important family *Icteridae* is strictly American, and is pretty closely allied to the starlings (*Sturnidae*) of the Old World. Among the Icterids, or American orioles, are grouped our blackbirds, bobolinks (*q. v.*), meadow-larks, cow-birds (*q. v.*), troopials, and grackles. The family is separated from the *Fringillidae* (finches, sparrows, buntings, etc.) by very obscure, if not intangible, distinctions; some of them, like the bobolink, or reed-bird, might almost as well be classed with the finches as with the *Icteridae*. On the other hand, some of the family approach pretty closely to the crows in many of their characters. The subfamily, *Icterinae*, contains those species more properly called orioles.

The most common North American oriole is *Icterus spurius*, the orchard oriole, or "bastard Baltimore bird," as it is sometimes unjustly called. This rather plain bird is found in all parts of this country and is well known for its beautifully-woven and somewhat pensile nest. The splendid Baltimore oriole (*I. galbula*) takes its name from the black-and-orange livery of the Calvert family, to which the Lords Baltimore belonged. The male is, as usual among birds, far more showy than his modest spouse. There is much difference, however, among the males of this species, some of which have a very gorgeous coloration, while others are comparatively plain. Among the popular names for this favorite are golden robin, firebird, fire hangbird, and hangnest, the last names bestowed from its well-known habit of constructing a bag-like, pendant, and well-woven nest at the extremity of some swaying branch. It is a persistent and noisy singer, with a monotonous tune.

Farther west this species is replaced by *L. bullocki*, Bullock's oriole, a larger but not dissimilar species. In the extreme South-west and on the Mexican frontier we find the hooded oriole (*L. cucullatus*) whose general coloring is orange of varying but showy tints, mixed with black. In the same region are found *I. parisorum*, the "Paris brothers' oriole," and the very large and handsome *I. melanocephalus*, the black-headed or Audubon's oriole. In Mexico it is highly prized as a cage-bird, and its singing is said to be remarkably fine. (C. W. G.)

ORR, JAMES LAWRENCE (1822-1873), statesman, was born at Craytonville, S. C., May 12, 1822. He graduated at the University of Virginia in 1842, studied law, and was admitted to the bar in 1843. He entered on practice at Anderson, S. C., where he edited a newspaper. In 1844 he was elected to the State Legislature, and in 1849 to Congress. While holding the abstract right of secession on the part of each State he long opposed its exercise as inexpedient. This position he maintained in the Southern Rights Convention at Charleston in May, 1851. He was chosen Speaker of the House of Representatives in 1857. After the election of Lincoln to the presidency he became an advocate of immediate secession, and as such took part in the South Carolina Convention in December, 1860. He was then appointed one of three commissioners to Washington to treat with the

Federal government for the surrender of the U. S. forts in Charleston harbor. Although not officially received by Pres. Buchanan, their mission was not without effect. After the Confederate government was formed, Orr was elected to the Senate and there remained till the end of the war. Acquiescing in the result he was made governor of South Carolina in 1866, and held that position till 1869. He was appointed U. S. circuit judge in 1870, and was sent as U. S. minister to Russia in 1873. He died at St. Petersburg, May 5, 1873.

ORTON, JAMES (1830-1877), an American naturalist, was born at Seneca Falls, N. Y., April 21, 1830. He graduated at Williams College in 1855 and at Andover Theological Seminary in 1858. After a year's travel in Europe and Asia Minor he became a Congregationalist minister. In 1866 he was made an instructor in natural science in Rochester University, and in 1867 he led the Williams College Expedition which explored the Upper Amazon. He was made professor of natural history in Vassar College in 1869. He made a second visit to the Amazon in 1873, and in a third visit to South America he died while crossing Lake Titicaca, Sept. 24, 1877. He published *The Andes and the Amazon* (1870); *Underground Treasures; How and where to find them* (1872); *Liberal Education of Women* (1873); *Comparative Zoölogy* (1875).

OSAGE ORANGE. This is the common title of *Maclura aurantiaca*, known also by the French title of Bois d'Arc, a tree native to the contiguous portions of Arkansas, Texas, and the Indian Territory, but which is coming largely into use as a hedge material in other States. It is extensively planted for hedges in the West, and to some extent in the East, and when kept properly clipped serves this purpose excellently. As a tree it attains a height of 50 feet and a diameter of 2 feet, being most common and prolific in the Red River Valley of the Indian Territory. Its wood is heavy, exceedingly hard, close-grained, strong, and flexible, of a satiny surface, and susceptible of a beautiful polish. Its color is a bright orange, which turns brown on exposure. It is very durable in contact with the ground, and is used largely for fence-posts, paving-blocks, railway-ties, and wheel-stock.

OSAGES, a tribe of American Indians of the Dakota family, were known in the seventeenth century as living on the Missouri and being allied with the Illinois. They are reported to have assisted the French against their hereditary enemies, the Foxes, in 1712, and some of their chiefs were taken to France in 1726. They continued to aid the French until the power of this nation was overthrown in America. Early in the present century they numbered about 6000, of whom the Great Osages resided on the Arkansas River and the Little Osages on the Osage River. By a treaty made Nov. 10, 1808, the chiefs ceded some of their lands, and the tribes afterwards repudiated the treaty. But as they were driven out by the whites, they engaged in warfare with the Cherokees and other tribes. Other treaties followed, and were no better kept than the first. They lived by plundering, and resisted all efforts to civilize or Christianize them. The border war in Kansas and the civil war had a disastrous effect upon them, since they sided with the Confederacy. After the war efforts were made to induce them to remove to Indian Territory. Finally this was effected in 1872, but they were deprived of their cattle and other property. When they were settled in their reservation, north of the Cherokee country and west of 96° N. lat., Pres. Grant, in carrying out his "Peace policy," assigned this tribe to the Society of Friends. Schools have been established and agriculture encouraged, with good effect. Capt. C. H. Potter reported them in 1887 as rich and indolent. They receive over \$35 quarterly per capita from the interest on the Osage fund. The number on the reservation was stated as 403 men, 399 women, 391 children; total, 1193.

OSCAR II., FREDERIC, king of Sweden and Norway, was born at Stockholm, Jan. 21, 1829. In his youth he served in the navy. He was educated at the University of Upsal, under the historian Carlson, and travelled on the Continent. He succeeded to the throne on the death of his brother Charles, Sept. 18, 1872. He reorganized the army and the railroads. In 1873 he visited Norwegian Lapland, and in 1875 the emperors of Germany and Russia. He sent his son to travel through Europe and to visit the Centennial Exhibition at Philadelphia. King Oscar has fine literary taste, and has published translations of Goethe's *Fuust* and *Tasso*. He is also the author of a sketch of Charles XII. and of a volume of poems.

OSCEOLA (1804-1838), Indian warrior, was born on the Chattahoochee River, Ga., in 1804. His name means "Black drink," and was given to denote his courage, as shown by his drinking that nauseous mixture. He was the son of William Powell, an Englishman, by an Indian mother. Early distinguished in the dances, games, and athletic exercises of the Seminoles, he gained great influence in the tribe, and opposed the cession of its lands in Florida. His wife was the daughter of a fugitive slave, and in 1835 was herself seized as a slave. Osceola then demanded her return from Col. Thompson, the U. S. agent at Fort King, but the latter, resenting his language, ordered him to be confined in irons for six days. In December, six months later, Osceola avenged this injury by killing Thompson and others. He then entered upon a vigorous warfare against the whites, massacred Maj. Dade and his command, and fought Gen. Clinch at Withlacoochee. He also had several encounters with Gen. Gaines, and made attacks on Forts Micanopy and Drane. At last, while holding a conference with Gen. Jesup under a flag of truce, near St. Augustine, Oct. 22, 1837, he was treacherously seized, and was thereafter imprisoned at Fort Moultrie, S. C., where he died Jan. 30, 1838.

OSGOOD, FRANCES SARGENT (1811-1850), poet, was born at Boston, June 18, 1811, being the daughter of Joseph Lock, a merchant. She attracted the notice of Mrs. L. M. Child, and contributed to her *Juvenile Miscellany*. In 1835 she was married to Samuel Stillman Osgood, a portrait-painter, with whom she visited London. There she contributed to periodicals, and published *A Wreath of Wild Flowers from Neo England* (1839) and *Elfrida*, a drama (1839). After her return to Boston she published *The Poetry of Flowers* (1840) and *The Floral Offering*. A complete collection of her poems appeared in 1849. She died at Hingham, Mass., May 12, 1850. A *Memorial* by R. W. Griswold was published in 1851.

OSHKOSH, a city of Wisconsin, the county-seat of Winnebago co., is 85 miles N. W. of Milwaukee, on both banks of the Fox River, which here expands into Lake Winnebago. The lake is 30 miles long and from 12 to 15 miles wide, and with the Fox and Wisconsin, which are connected by a short canal, forms a water-route between Lake Michigan and the Mississippi. Oshkosh has a lake frontage of nearly 4 miles, towards which its surface slopes gradually, giving excellent drainage. The Fox River is spanned by 3 wagon-draw-bridges and 3 railroad-bridges. Four railroads pass through the city. Oshkosh has a U. S. government building, a fine city-hall, county court-house, Masonic temple, exposition building, 2 opera-houses, and other buildings of attractive architecture; 24 church edifices, a State normal school, a high-school, a business college, 8 public schools, and 8 private and parochial schools. There are 5 hotels, 2 national banks, 1 State bank, 2 daily and 4 weekly newspapers. The chief industry is in lumber, logs being floated from the northern pineries down Wolf and Fox Rivers. There are about 15 large saw-mills at Oshkosh, and factories which produce one-tenth of all the doors and sashes made in the United States. There are also several large furniture-factories, 4 extensive carriage-factories, the largest

match-factory in the world, 3 foundries and machine-shops, 3 soap-factories, several pork-packing houses. The business portion of the city is built chiefly of brick. The streets are lighted by electricity, but gas is used by private consumers. The water is supplied by the Holly system from a cluster of artesian wells. The assessed valuation of property is about \$8,000,000. The bonded debt is \$143,000, and the yearly expenses exceed \$200,000.

This locality was traversed by the early French explorers and missionaries, but the first permanent white settlement was made by New Englanders in 1836. The city was incorporated in April, 1853. In 1859 the entire town was destroyed by fire; in 1874 the extreme northern portion was swept away, and in the next year all of the city north of Fox River was consumed, the loss being about \$3,000,000. In 1885 part of the suburbs was destroyed by a cyclone. The population in 1880 was 15,748, and in 1888 it is estimated at 25,000. (C. W. D.)

OSKALOOSA, a city of Iowa, county-seat of Mahaska co., is 60 miles east of Des Moines, on the S. W. branch of the Chicago, Rock Island, and Pacific Railroad and the Central Railroad of Iowa. Oskaloosa is at the centre of the Iowa bituminous coal-fields. It has a fine court-house, which cost \$150,000, an opera-house, 4 hotels, 2 national banks, 2 other banks, 1 daily and 3 weekly newspapers, 9 churches, 5 schools, and 3 colleges. The industrial works comprise 2 foundries, electric manufacturing, boiler-works, bridge-works, and flouring-mills. The city is lighted with gas and electricity, and has a park and water-works. Its property is assessed at \$1,200,000, but is worth four times as much. The public debt is \$45,000, and the yearly expenses about \$21,000. Oskaloosa was settled in 1844 and incorporated in 1848. The population in 1880 was 4598, but now exceeds 7000.

OSMAN PACHA, a Turkish general, was born at Tokat, Asia Minor, in 1832. Having been educated at the military school at Constantinople, he entered the cavalry in 1854, and served under Omar Pacha. In 1860 he was engaged in Syria and in 1867 in Crete, where he became lieutenant-colonel. In 1874 he was made brigadier-general after taking part in the expedition to Yemen. He was afterwards placed in charge of the operations against the Servians. After the Russians in 1877 had crossed the Danube, Osman Pacha defeated their Ninth corps near Plevna, and then thoroughly fortified that city. On Sept. 14th he repulsed the Russian besiegers with a loss of 20,000 men. On Dec. 10th he made a gallant but unsuccessful effort to break through the Russian lines. Being wounded he was obliged to capitulate, surrendering 40,000 men and 400 cannon. His skillful conduct of the siege had given him fame as an engineer and commander. After the war, in March, 1878, the reorganization of the Turkish army was entrusted to him. He was made minister of war, commander of the imperial guard, and chief of the artillery. His influence with the sultan was, for a time, very great in spite of the jealousy of other ministers, but in 1880 he resigned and retired to private life.

OSWEGO, a city of New York, county-seat of Oswego co., is on the S. E. shore of Lake Ontario, at the mouth of the Oswego River, here crossed by three iron bridges. It is 35 miles N. N. W. of Syracuse, with which it is connected both by railroad and canal. Its site is elevated, and towards the south there is a bluff rising 160 ft. above the lake. The principal edifices are the U. S. government building, court-house, city-hall, the State armory, and some churches. Oswego has 5 national banks besides other banks, 20 churches, normal, training and graded schools, 2 daily and 3 weekly newspapers. It is the chief port on Lake Ontario, and has a large breakwater, 4 miles of wharves, and 12 grain-elevators. Grain and lumber are the chief imports and coal, flour, and salt the exports. Within the limits of the city the Oswego

River has a fall of 34 feet, and there are 6 dams to assist the canal navigation. The abundant water-power has rendered Oswego a noted manufacturing city. The starch-factory is the largest in the world, occupying 10 acres of ground and having buildings seven stories high. There are also flour-mills, iron-foundries, machine-shops, ship-yards, car-shops, knitting-mills, etc. Fort Oswego was built in 1727, and was noted in the French and Indian war. In 1814 it was captured by the British. In 1828 the village was incorporated, and in 1848 it was made a city. In 1880 its population was 21,116.

OTIS, HARRISON GRAY (1765-1848), Federalist, was son of Samuel Alldyne Otis (1740-1814), who was secretary of the U. S. Senate from 1789 to 1814, and nephew of James Otis (for whom see *ENCYCLOPEDIA BRITANNICA*). He was born at Boston Oct. 8, 1765, graduated at Harvard College in 1783, and was admitted to the bar in 1786. He served in the State Legislature and in Congress. In 1801 he was appointed U. S. district attorney for Massachusetts, but soon re-entered the State Legislature and presided in turn over each branch until 1811. With his party he opposed the war with England, and he took a prominent part in the Hartford Convention, of which he afterwards published a *Defence* (1824). Meantime he had been a judge of the court of common pleas and in 1818 had been again elected to Congress. His last public service was as mayor of Boston in 1829, but he lived nearly twenty years longer, and died in that city Oct. 28, 1848.

OTTAWA, a city of Illinois, county-seat of La Salle co., is at the confluence of the Fox and Illinois Rivers, 82 miles S. W. of Chicago, on the Chicago, Rock Island, and Pacific Railroad, and on a branch of the Chicago, Burlington, and Quincy Railroad. There are three bridges across the Fox River and two across the Illinois, besides the bridges over the Illinois and Michigan Canal. The city has a State Supreme court-house, a county court-house, 2 national banks, 7 weekly and 2 daily papers, 6 hotels, 12 churches, 8 schools besides the high-school, and the Reddick Library. The abundant supply of white sand in the vicinity gives facilities for glass-making, there being 6 furnaces, one of which produces the Bastic lamp-chimneys. There are also tile-works, fire-proofing-factories, flour-mills, a foundry, and manufactories of agricultural implements, wagons, organs, and pianos. Ottawa is beautifully situated on a level plateau about 30 ft. above the river, has excellent drainage and an abundant water supply, both from a natural reservoir formed by a gravel bed on the south side of the city and from numerous artesian wells. These wells, having an average depth of 350 ft., give a supply of 50 gallons each per minute. The analysis of the Ottawa mineral spring, by Prof. Benjamin Silliman, showed it fairly equal in bromine and iodine to the Saratoga Springs. Ottawa was settled in 1830, incorporated in 1835 as a village and in 1853 as a city. It is lighted with gas and electric light. Its property is valued at \$1,250,000, and its city debt is \$17,500; the yearly disbursements are about \$50,000. Its population in 1880 was 7834.

OTTER. Concerning the North Pacific sea-otter, *See* Vol. XVIII. *Enhydra lutris*, it will be sufficient to add that their furs at present command an exceedingly high price, the principal market or port for their collection and shipment being the little town of Belkofsky in Alaska, though considerable numbers are taken in some years much farther to the south.

The most common otter of North America is *Lutra canadensis*, a true otter, much larger than the closely kindred European species. Specimens measuring five feet from the end of the nose to the tip of the tail are not uncommon in remote places. This species ranges throughout North America, but is exceedingly rare in well-settled districts. Some have classed the *L.*

californica of the Pacific coast, and even one or more of the rather numerous but imperfectly known South American species of otter, as mere variants of the species. The common otter is chiefly hunted in winter, when its fur is at its best. It is fond of the amusement of sliding down-hill upon the belly, an amusement which it practices in winter upon the snow and ice and in summer upon some steep bank which slopes into a pool or deep stream. Unlike some of the other otters, it is a swift runner. It lives upon fish and is seldom seen far from the water. It is cunning in pursuit, and when brought to bay will fight with great courage, often proving itself a formidable antagonist to a dog or man. It is generally taken in steel traps. Besides the interesting and little-studied otters of South America allusion may here be made to the yapock (*Cheironectes yapock*) of South America, called the "little otter" in British Guiana. It is decidedly otter-like in its habits, but in reality it is only a semi-aquatic opossum, being one of the most strictly aquatic marsupials anywhere known. It may be added that a certain proportion of the otter skins of commerce are furnished by the strongly aberrant species which are found in Southern Asia, but their skins are usually small and the pelage is said to be poor.

(C. W. G.)

OTTERBEIN, PHILIP WILLIAM (1726-1813), the founder of the Church of the United Brethren in Christ, was born at Dillenburg, Germany, June 4, 1726. He was ordained as a minister of the Reformed Church at Herborn in 1749, but in 1752 followed the call of Rev. Michael Schlatter to become a missionary to the German settlers in America. He took charge of the church at Lancaster, Pa., but being disheartened by the prevailing indifference to religion he was led to join with Christians of other denominations in religious meetings held in the groves. In 1758 he removed to Tulpehocken, Pa., and afterwards to Frederick, Md., and to York, Pa. In 1774 he took charge of an independent congregation at Baltimore. He had sought fellowship in his spiritual views among the ministers of other denominations, and he fraternized especially with Asbury and with Martin Böhm. In 1784 he assisted Dr. Coke in ordaining Asbury as the first bishop of the Methodist Episcopal Church. In 1800 a conference called by him at Baltimore was attended by thirteen ministers, who formed the Society of the United Brethren in Christ. Although this eventually became a separate denomination, Otterbein is said never to have left the communion of the German Reformed Church. Meantime he and Böhm were recognized as its superintendents and have been called bishops, though that title seems not to have been used till after Otterbein's death. He died at Baltimore, Nov. 17, 1813. See *Life of P. W. Otterbein*, by Rev. A. W. Drury, D. D.

OTTUMWA, a city of Iowa, the county-seat of Wapello co., is on the Des Moines river, 76 miles W. of Burlington. The county was opened for settlement by the removal of the Sac and Fox Indians in 1843. Ottumwa was incorporated as a city in 1857 and then occupied a narrow strip of flat land between the river and the bluffs. This land is now covered by solid brick business blocks, while the residence portion of the town spreads out over the bluffs which attain an average elevation of about 150 feet. The town originally lay entirely east of the river, but in 1884 the city limits were extended and the west side has a population of about 1500. The length of the city along the river is about three miles. Its population in 1885 by the State census was 10,506. It is well supplied in the way of transportation facilities, being on the main line of the Chicago, Burlington, and Quincy Railroad, also on the Kansas City branch of the Chicago, Milwaukee, and St. Paul Railroad, and is the terminus of the Central Iowa and Wabash roads. Its other roads are the Keokuk and Des Moines branch of the Chicago, Rock Island, and Pacific and the Ottumwa and Kirk-

ville, a short coal-road. A Union passenger depot has been built at a cost of \$125,000. This point of the Des Moines River was known to the Indians as "Ottumwa-e-noeh," signifying "swift water ford," the river at that time falling six feet over a rock bottom in the course of a half mile. In 1876 advantage was taken of this fall, and at an expense of about \$150,000 extensive dams were put in and abundant water-power obtained. The other advantages of the site, cheap coal (bituminous), excellent building stone, and the railroad facilities, have given an impetus to manufacturing. Among the industrial works are a starch-mill, linseed-oil-mill, 2 iron- and brass-foundries, a ruffler-factory, 2 machine-shops, plow-, cutlery-, and screen-factories, planing-mills, 2 furniture-factories, 2 boiler-works, 2 cooper-shops, 2 flour-mills, mining-drills, and bridge-works. There is also located here the second largest pork-packing-house in Iowa, killing 150,000 hogs a year. Ottumwa is also the centre of a large jobbing trade.

The public school system of the city comprises 4 buildings on the east side and one on the west side, erected at a cost of \$125,000. There is also a large Catholic academy, a normal school, and a business college. There are 15 churches, 2 opera-houses, 3 national banks, 6 hotels, and 2 daily and 6 weekly papers.

The city has excellent water-works, affording exceptional fire protection, gas, and arc and incandescent electric lights. There are six miles of street railway, operated by three companies. The system of sewerage is very complete.

The assessed valuation of city property is \$3,000,000, about one-third its actual value. The debt is \$54,000, and the expenses of the city in 1886 were \$40,378. Ottumwa is in the heart of the Iowa coal-fields and is built over a 44-foot vein of coal.

(A. H. H.)

OUSELEY, SIR FREDERICK ARTHUR GORE, an English musician, was born at London, Aug. 12, 1825, being the only son of Sir Gore Ouseley (1768-1844), ambassador to Persia and Oriental scholar. He graduated at Christ Church, Oxford, in 1846, took orders, and was curate of the Church of St. Barnabas, London, in 1849-50. He had also devoted himself to the study of music and received the degree of B. Mus. in 1850 and that of D. Mus. in 1854. For the latter he prepared an oratorio, *The Martyrdom of St. Polycarp*. He was made precentor of Hereford Cathedral in 1855, and also professor of music at Oxford, succeeding Sir Henry R. Bishop. From his means he built the Church of St. Michael, at Tenbury, of which he was first vicar. He is also warden of St. Michael's College, which had grown out of his labors as choir-master. He is noted for his attainments in music, and has published many anthems, the oratorio of *Hagar*, and standard treatises on *Harmony* (1869), on *Fugue and Counterpoint* (1869), and *Form in Music* (1875). He has also edited valuable collections of cathedral music.

OWEGO, a village of New York, county-seat of Tioga co., is on the Susquehanna River, at the mouth of Owego creek, 37 miles east of Elmira. The Erie Railroad is here crossed by the Southern Central and connects with the Delaware, Lackawanna, and Western. Owego has a fine court-house, 2 national banks, 8 churches, an academy, and graded schools, 3 weekly newspapers. The industrial works comprise a piano-factory, carriage-works, flour-mills, and manufactories of soap, leather, etc. Its population in 1880 was 5525.

OWEN, DAVID DALE (1807-1860), geologist, was born in Lanarkshire, Scotland, June 24, 1807. He was a son of the socialist, Robert Owen (1771-1858), for whom see ENCYCLOPÆDIA BRITANNICA. David was educated with his brother at Fellenberg's school at Hofwyl, Switzerland, and in 1825 settled with his father at New Harmony, Ind. He afterwards went to Germany to study natural science, and in 1833 returned to Indiana. In 1837 he was appointed by the Legislature

to make a geological survey of that State, and subsequently he was employed by the U. S. government in geological surveys in Iowa, Wisconsin, and Minnesota. The results were published in 1852. His surveys of Kentucky and Arkansas were conducted under the direction of those States, and he was also employed by individuals and companies in examination of special districts. He died at New Harmony, Ind., Nov. 13, 1860.

His brother, ROBERT DALE OWEN (1801-1877), became especially noted as an advocate of spiritualism. He was born at Glasgow, Nov. 7, 1801, but spent his early years at New Lanark, and three years in Switzerland. He went with his father to the United States in 1825, and took part in the social experiment at New Harmony, Ind. In 1828, for the promotion of infidelity, he established at New York a weekly paper called *The Free Inquirer*. While a member of the Indiana Legislature, 1835-38, he did much to promote common schools, and in Congress, 1843-47, he took part in organizing the Smithsonian Institution. In 1850 he served in the convention for the revision of the Constitution of Indiana, and secured for married women the control of their property. From 1853 to 1858 he was at Naples, at first as U. S. *chargé d'affaires*, afterwards as minister. During the civil war he supported the cause of the Union, and urged the emancipation of the slaves. He was employed by the government on important commissions relating to the freedmen and to ordinance stores. His later years were devoted to the propagation of spiritualism. He died at Lake George, N. Y., June 24, 1877. His principal works are *Footfalls on the Boundary of Another World* (1860); *The Debatable Land between this World and the Next* (1872), and *Threading my Way* (1874), the last being an autobiography of twenty-seven years.

OWEN, JOHN JASON (1803-1869), an American educator, was born at Colebrook, Conn., Aug. 13, 1803. He graduated at Middlebury College, Vt., in 1829, and studied theology at Andover. Although he entered the Presbyterian ministry, he was never pastor, his life being devoted to teaching and editing the classics. He was principal of the Cornelius Institute, New York, from 1836 to 1848, when he was made professor of Greek and Latin in the New York Free Academy. While he was vice-president of this institution its name was changed to the College of the City of New York. He died at New York, April 18, 1869. His publications were editions of Xenophon's *Anabasis* (1843), and *Cyropædia* (1846); Homer's *Odyssey* (1844) and *Iliad* (1851), a *Commentary on the Gospels and the Acts* (3 vols., 1857-69). He was an able scholar, faithful teacher, and learned commentator.

OWEN, SIR PHILIP CUNLIFFE, a British promoter of industrial art, was born June 8, 1828. His father being a captain in the British navy, he was engaged in that service from his 12th to his 17th year. Being then compelled to retire by ill-health he received an appointment in the science and art department at London. After faithful service for ten years he was appointed deputy-general superintendent of the South Kensington Museum. In 1860 he was made assistant director, and in 1873 succeeded Sir Henry Cole as director. He assisted at the Paris Expositions in 1855 and 1867, and was executive commissioner at the Centennial Exhibition at Philadelphia in 1876. He was secretary of the Royal commission for the Vienna Exposition in 1873, and for the Paris Exposition in 1878. He also took part in the International Fisheries Exhibition at London, 1883, the Health and Education Exhibitions, 1884, the Music Exhibition, 1885, and the Colonial and Indian Exhibition, 1887. In all of these cases he displayed great executive ability and essentially promoted the objects of the industrial exhibitions. Besides being knighted in 1873, he has received various marks of honor from his government.

OWEN, SIR RICHARD, English anatomist, was born at Lancaster, July 20, 1804. He studied medicine at Edinburgh and at St. Bartholomew's Hospital, London, becoming prosecutor to Abernethy. He became a member of the Royal College of Surgeons in 1826, and soon after assistant curator of the Hunterian Museum. Besides descriptive catalogues of the museum, he prepared the *Physiological Series of Comparative Anatomy* (1833-40). His valuable researches led to new classifications of animals and the addition of numerous genera and species. His ability was displayed in the reconstruction of extinct families. In 1836 he succeeded Sir Charles Bell as Hunterian professor in the Royal College of Surgeons, and in 1856 was made chief of the natural history department of the British Museum; he also held a professorship in the Royal Institution, London, and was connected with the prominent scientific societies. Among his works are: *Odontography* (2 vols., 1840-45); *British Fossil Mammals and Birds* (1846); *British Fossil Reptiles* (1848-55); *The Vertebrate Skeleton* (1848); *Parthenogenesis* (1849); *Lectures on Comparative Anatomy* (1843-46); *Anatomy of Vertebrates* (3 vols., 1866-68); *Fossil Reptilia of South Africa* (1875); *Fossil Mammals of Australia* (1877); *Wingless Birds of New Zealand* (1880).

OWENSBORO, a city of Kentucky, the seat of Daviess co., is on the Ohio River, 160 miles below Louisville, and on the Owensboro and Nashville, the Louisville, Evansville, and St. Louis, and the Louisville, St. Louis, and Texas Railroads. It is 10 feet above the highest water ever known in the Ohio River. A steam-ferry plies to Indiana and considerable trade is carried on by the river packet-lines. Owensboro has a U. S. government building, 4 hotels, 1 national bank, 4 State banks, 1 daily and 4 weekly newspapers, 16 churches, good public schools, and private academies. The manufacturing industries comprise 2 foundries, wagon-factory, wheel- and spoke-factory, planing-mills, flouring-mills, and tobacco- and cigar-factories. The chief staples of the vicinity are tobacco and whiskey, there being 23 tobacco-factories and 16 whiskey-distilleries. The city is lighted with gas and electric light, and is supplied with water by the Holly system. Its property is valued at \$3,000,000, its public debt is \$25,000, and the yearly expenses are \$47,000. It was settled in 1815, and incorporated as a city in 1850. Its population in 1880 was 6231.

OWL. To the remarks found in the *ENCYCLOPEDIA BRITANNICA* regarding the structural affinities of the owls, it may be added that the hawk-owl (*Surnia* *funerea*) of both continents is the most

acceptitine of known owls and furnishes the best argument that remains to those systematists who still cling to the grouping of the owls with the hawks and other diurnal birds of prey in the old and familiar order of *Raptores*. Some have found in the singular kakapo, or owl-parrot, a link between the owls and parrots, but though there seems to be a certain relationship between the parrots and the true birds of prey, it must be conceded that the kakapo is after all only an aberrant and strictly local form of the parrot tribe—an owl, it is true, in its physiognomy and in its nocturnal habits, but in no other respect. The relationship of owls through *Statornis* to the goatsuckers is now generally given up as improbable, but the best recent opinion would seem to place the owls, the goatsuckers, and the guacharo in the position of parallel groups derived from some common parentage, probably belonging to that convenient yet confused and somewhat bewildering assemblage, the Picarian birds. (See ALUCONIDÆ.)

It is certainly remarkable that while the keen-eyed and strongly flying sub-family of Old World vultures have not a single representative in America, being replaced here by the totally distinct *Cathartidæ* (*q. v.*), several species of the owls, on the other hand, have

been able to spread over a large part of the world, six of our fourteen acknowledged species being European



Hawk-Owl.

as well as American. The burrowing owl (*Speotyto cucicularia*), which ranges from Canada southward to Patagonia, affords another example of the similar wide distribution of a remarkably interesting species.

OYSTER. The American oyster (*Ostrea Virginica*) has a wide range of distribution, being found at all suitable points along the Atlantic coast from Florida to the southern shores of the Gulf of St. Lawrence, and along the northern coast of the Gulf of Mexico.

In some portions of this range it occurs in natural beds of enormous extent; that of Long Island Sound is said to be fully 115 miles in length, the oysters not being confined to the sound but extending around New York Bay and into the small bays along the Jersey shore. Oysters are often brought here from Chesapeake Bay and planted in the sound to supply the beds that have become exhausted by over-dredging.

In the waters of Virginia there is said to be 2,000,000 acres of oyster beds, while in Chesapeake Bay, with its many inlets and river mouths, the oyster finds its best adapted home, the bivalve here attaining its highest excellence and flourishing enormously. The bottom of the bay is almost covered with beds of the finest oysters in the world. Baltimore is the most important mart in the oyster trade and cans and pickles vast quantities of oysters for shipment to the West and to foreign countries. Farther down the coast oysters occur plentifully but are only gathered for local use. On the coast of Georgia they are said to exist in such multitudes as to form natural breakwaters sufficiently firm to resist the billows of the ocean. The coast region here is made up of salt marshes from twelve to eighteen miles wide, through which slow-flowing rivers make their way to the sea. These streams flow between banks of living oysters, so closely compacted that a vessel might, in some places, obtain a cargo in a space not more than three times its length.

Oysters abound in the inlets and small bays on the north shore of the Gulf of Mexico. In the Bay of Mobile they are plentiful and of excellent quality, and are cultivated on a large scale. In Louisiana are beds

of oysters said to be unsurpassed in size and flavor. On the Pacific coast oysters occur abundantly in the Strait of Fuca and in Puget Sound; these are quite small, but of fine flavor. The Eastern oyster has been introduced and seems to be susceptible of easy cultivation.

The American oyster is exceedingly prolific, far more so than its European counterpart, which produces about 2,000,000 young, while the American bears from 10,000,000 to more than 60,000,000 in some instances. The European oyster takes some degree of care of its young, keeping them within the folds of the mantle until they are several days old, while in the American oyster fertilization takes place in the water and the young are exposed from birth to the perils of the waves, so that they are destroyed in far greater numbers than in the case of the European. The minute embryo bivalves swim about by the aid of cilia for several days, feeding on the minutest life-forms of the ocean, after which they fix themselves to some substance to which one of the shell valves becomes cemented. There, if not artificially removed, the remainder of their life will be spent. The American oyster grows much faster than the European and attains a considerably greater size. At the end of a fortnight's growth it is of the size of a pin's head; in three months it attains the size of a pea; then it grows more rapidly, becoming an inch long in six months. It is ready for market in about three years, and its average life is about ten years, though thirty-year-old oysters have been known. These old oysters, at times, attain great size; one found in Mobile Bay is said to have been more than 3 ft. long and nearly 2 ft. broad, but they rarely exceed 3 in. in width, though often found over a foot long. When grown under favorable circumstances the shells, at first round, become oval in shape with undulated and scalloped edges, but after the first winter become elongated and irregular, the shape being greatly governed by that of the object to which the oyster is attached. In the natural banks the oysters become so crowded that they are apt to stand in a vertical position, the hinge downward and the mouth of the shells upward. Being contracted laterally they often become very long and narrow, forming what are known as "raccoon oysters," or "eat's tongues." The lower layers of these beds are smothered and die through the annual additions above.

The mortality of the young oysters is enormous, very few individuals of each batch of millions surviving. They have many enemies, while great numbers perish from lack of a clean surface to which to attach themselves, being smothered in their embryo state by a very thin layer of mud or slime. The mature oysters, also, have many enemies, chief among them the star-fish and the "drill," or boring whelk, yet in spite of these and their human foes, it is only the lack of proper conditions of sea bottom that limits the indefinite increase of the oyster beds. The oyster, in fact, cannot live except under certain conditions of depth and salinity of water, and of firmness of bottom, a mixture of clay and mud forming favorable ground. Soft mud is fatal, and deposits of mud through storms may cause great injury. The young oysters attach themselves to the shells of older ones and beds of great thickness are thus gradually formed. On the western coast of Florida, and in other tropical regions, they attach themselves to the roots and limbs of the mangrove trees. Natural beds can be enlarged and artificial beds made by the deposition of shells, gravel, or tiles over muddy bottoms. Oyster-shells are much used as "cultch," to which the young fry attach themselves and from which they may be transplanted. Seed-oysters are thus carried from Virginia and Maryland to the beds of the North, where they are planted in shoal waters to be fattened for market.

Prof. Ryder speaks of having examined oyster beds in water so shallow that the animals are almost entirely exposed to the air during low tide. In severe

winters a considerable proportion of the oysters in these beds are destroyed by freezing; yet the animals are so prolific that the beds are said to be fully restored in a year or two. The movement of the tides is an advantage to these beds, in keeping them clean, and in bringing a full supply of the minute animals and plants which form the food of the oyster.

Of late years the study of the embryology of the oyster has been diligently prosecuted under the auspices of the United States Fish Commission, with the ulterior purpose of successful artificial propagation. The experiments have been attended with promising indications, though no practical application of the results has been made. It is found that artificial fertilization of the eggs can be easily performed, and that the young can be kept alive until ready to attach themselves. This, however, is of minor importance, as natural fertilization can be easily employed under favorable conditions. The important purpose to be attained is that of the protection of the fry until ready to attach itself, the preparation of abundant and properly distributed culch for attachment, and arrangements for readily transplanting the young without injury.

Several scientists of the Commission have given attention to this subject, among them Profs. Brooks and Winslow, and more recently Prof. John A. Ryder, who has devoted several years to the study. He advises the use of spawning ponds with systems of canals, into which the tides can ebb and flow daily, while by the aid of a filtering apparatus the enemies of the oyster can be in great measure excluded. The canals are to be so arranged as to contain within a limited space a very considerable number of movable collectors, consisting of frame-work filled with tiles, slates, shells, etc. The water is made to flow through the full length of these collectors, and as the fry is swept by the tide backward and forward it attaches itself to the culch in the frames. The collectors being movable can be rocked on their supports, and the sediment which is so fatal to the young oyster washed out. When the seed-oysters are sufficiently grown they can be easily removed by lifting out the framework, and conveying the culch in boats to the beds in which it is desired to plant the young oyster as seed.

Prof. W. K. Brooks proposes the use of floating collectors, saying that the embryo has a tendency to swim to the surface, and that culch in floating cages would be free from danger of sediment, that fatal

enemy of the larval oyster. In an experiment which he tried he obtained a good "set," and the young oyster grew with remarkable rapidity, signifying an abundant supply of food and other favorable conditions.

It is obvious that in the modes here indicated it is possible to obtain an abundant supply of healthy seed-oysters, particularly in that proposed by Prof. Ryder, which is the outcome of long study and experiment, and in which the unfavorable conditions are in great measure eliminated. Similar care of the subsequent growth of the oyster is necessary. As planted in open beds it has two destructive enemies, the star-fish and the inconsiderate dredger, who often destroys more oysters than he collects. At the Island of Ré, on the coast of France, vast numbers of oysters are raised in small "parks," separated by walls, and planted with seed-oysters. As a consequence this small island, of about twelve miles circumference, now yields annually 400,000,000 oysters on what were originally its shores of deep and useless mud. Prof. Ryder believes that the salt marshes of many localities on our Atlantic coast could be similarly utilized, oyster ponds of three or four feet in depth being dug and connected with tide water by canals, while the inflowing water could be filtered of its dangerous ingredients. Abundant oyster-food would grow in such ponds. In this way, he thinks, the harvest of the American oyster could be enormously increased. As yet, however, the natural and planted beds yield a good supply, and the extension of the area of cultivation will probably be left for the future.

The fattening of the oyster is a subject of some interest. What we call fat in the oyster is really not fat at all, but a deposit of the purest and most nutritious protoplasm, which forms a highly digestible food. It is laid down in the mantle of the animal during the winter season, and exhausted during the reproductive period, when the oyster becomes very poor and non-nutritious. The so-called fattening by removing the oysters for a few days to water fresher than that in which they grew is a dealer's fraud. The oyster is plumped out by absorbing the fresh water, and the only real effect is that it loses part of its saltiness. Some dealers even use steam to warm the water, so as to induce the oysters to take in more.

We give, from the 1880 Census Report, the most recent general statement of the American oyster industry.

Oyster Industry of the United States, according to Census Report of 1880.

States.	Persons Employed.	Capital Invested.	Bushels Produced.	Value to Producer.	Value of Sales.
New Hampshire.....	9	\$ 2,400	1,000	\$ 800	\$ 6,050
Massachusetts.....	896	303,175	36,000	41,800	405,550
Rhode Island.....	650	110,000	163,200	225,500	356,925
Connecticut.....	1,006	361,200	336,450	386,625	672,875
New York.....	2,724	1,013,000	1,043,300	1,043,300	1,577,050
New Jersey.....	2,917	1,057,000	1,975,000	1,970,000	2,080,625
Delaware.....	1,065	145,000	300,000	325,000	687,725
Maryland.....	23,402	6,034,350	10,600,000	2,650,000	4,730,476
Virginia.....	16,315	1,351,100	6,837,320	1,948,636	2,218,376
North Carolina.....	1,020	68,500	170,000	60,000	60,000
South Carolina.....	185	12,250	50,000	20,000	20,000
Georgia.....	350	18,500	70,000	35,000	35,000
Florida.....	166	22,000	78,600	15,950	15,950
Alabama.....	300	16,000	104,500	44,950	44,950
Mississippi.....	60	3,000	25,000	10,000	10,000
Louisiana.....	1,400	36,750	295,000	200,000	200,000
Texas.....	240	17,750	95,000	47,300	47,300
Washington Territory.....	85	6,550	15,000	10,000	45,000
Total.....	52,805	\$10,583,295	\$22,195,370	\$9,034,861	\$13,438,852

The total value of sales includes for Maine \$37,500, and for Pennsylvania \$187,500, Philadelphia being an important seat of the oyster trade.

P.

PACA, WILLIAM (1740-1799), a signer of the Declaration of Independence, was born at Wye Hall, Harford co., Md., Oct. 31, 1740. He graduated at the College of Philadelphia in 1759, and studied law at Annapolis. He became a leading lawyer in Maryland, and his opinion on the poll-tax for the support of the clergy was republished in England. In 1771 he was elected to the Legislature, in which he advocated the rights of the colonists against the proprietor. His activity as a patriot caused him to be sent as delegate to the Continental Congress in 1774. Though employed in important business, he and his colleagues were long restrained by the Convention of Maryland from advocating separation from the mother country. But at the end of June, 1776, permission was obtained and Paca signed the Declaration. While still a member of Congress he served in the State Senate for two years. In 1778 he was made chief-judge of the Superior Court of Maryland, and in 1780 chief-judge of the Court of Appeals. In 1782 he was elected governor of Maryland and again in 1786, each term being a single year. He was a member of the State Convention which ratified the Federal Constitution. When the U. S. Judiciary was organized in 1789, he was made district judge of Maryland, and held this office till his death in 1799.

PACKARD, ALPHEUS SPRING (1799-1884), an American educator, was born at Chelmsford, Mass., Dec. 20, 1799. He graduated at Bowdoin College in 1816, and after studying theology returned to it as tutor in 1819. After being professor of Latin and Greek for forty years he was in 1864 transferred to the Collins professorship of natural and revealed religion. On the retirement of Pres. J. L. Chamberlain in 1883 he became acting president. He died July 13, 1884. He had been librarian of the Maine Historical Society 48 years. Besides contributing to various periodicals he published an edition of Xenophon's *Memorabilia* (1839), a *History of the Bunker Hill Monument Association*, and with Prof. N. Cleveland a *History of Bowdoin College* (1882).

His son, **ALPHEUS SPRING PACKARD, Jr.**, noted as a naturalist, was born at Brunswick, Maine, Feb. 19, 1839. He graduated at Bowdoin College in 1861, studied natural history under Prof. L. Agassiz and the Museum of Comparative Zoölogy. He also studied medicine, graduating at the Maine Medical College in 1864. He devoted himself chiefly to entomology, on which he lectured at Bowdoin College for many years. He has been curator of the Peabody Academy of Natural Sciences at Salem, Mass., and one of the editors of the *American Naturalist*, and has taken part in several scientific expeditions. He has published *Glacial Phenomena of Labrador and Maine* (1867); *Guide to the Study of Insects* (1869); *Our Common Insects* (1873); *Half-Hours with Insects* (1875); *Zoölogy for Students* (1879); *A Naturalist on the Labrador Coast* (1888); *Forest and Shade-Tree Insects* (1888). He has also published numerous monographs and some school-books. See Henshaw's *Entomological Writings of A. S. Packard* (1887).

PACKER, ASA (1806-1879), railroad constructor, was born at Groton, Conn., Dec. 20, 1806. In his boyhood he removed to Pennsylvania, and was engaged in canal-boating. As store-keeper, boat-builder, contractor, and coal-miner he steadily acquired wealth. In 1844 he was elected to the State Legislature, and was afterwards county judge for five years. About 1850 he projected the Lehigh Valley Railroad as an outlet for the anthracite coal region, and secured its construction and its subsequent extension to connect with the Erie Railroad and with New York city. In

1853 he was elected to Congress as a Democrat, and served two terms. In 1865 he announced his purpose to give \$500,000 and 115 acres of land for the erection of Lehigh University (*q. v.*), which was commenced immediately and attained a fair degree of prosperity in his lifetime. He died at Philadelphia, May 17, 1879. His will increased the endowment of Lehigh University to \$1,500,000, and his family have since made further gifts to the institution.

PADUCAH, a city of Kentucky, county-seat of McCracken co., is on the Ohio River, 48 miles above its mouth and at the mouth of the Tennessee. It is 225 miles by railroad W. S. W. from Louisville, next to which it ranks among the cities of the State. It carries on a large river-trade, and from it several lines of steamboats start. The Newport News and Mississippi Valley Railroad also gives facilities for trade, and has established here car-repair shops. The wholesale trade for 1886 was estimated at \$9,000,000 and the retail was still larger. Paducah contains a U. S. government building, a court-house, 3 national banks, 2 hospitals, 17 churches, 7 graded schools and a high-school, 2 daily and 2 weekly newspapers. The industrial works comprise 2 foundries, 4 saw-mills, 2 planing-mills, marine ways for building and repairing steamboats, and manufactories of soap, vinegar, ice, wagons, carriages, harness, brooms, flour, meal, and tobacco. The city is lighted with gas and has an efficient fire department and is supplied with water from the Tennessee River. The first settlement on the site was in 1821, the town was laid out in 1827, and received a city charter in 1856. In September, 1861, it was occupied by Gen. U. S. Grant, then commanding at Cairo, and throughout the war it was held by Union troops, although Gen. N. B. Forrest made a raid upon it in March, 1864. Its population in 1870 was 6866, and in 1880 was 8036.

PAGE, THOMAS JEFFERSON, commodore, was born at Shelly, Va., Jan. 4, 1808. His grandfather, John Page (1744-1808), was governor of Virginia, 1802-5. Thomas entered the U. S. navy in 1827 as midshipman, and was afterwards engaged in the Coast Survey. After a voyage around the world while lieutenant he planned a survey of the China seas, which was eventually changed to the expedition to Japan, commanded by Com. M. C. Perry. Page declined the second place in the expedition, but in 1853 commanded the expedition to explore the Rio de la Plata. While thus engaged his steamer was fired upon from a Paraguayan fort in February, 1855. He returned to the United States in May, 1856, having been promoted commander. In 1859 a fleet sent out by his government obtained from Paraguay reparation for the attack upon him. He completed his surveys in 1860, and in the next year resigned his commission and entered the Confederate service. He was engaged in resisting Gen. McClellan's advance on Richmond, but afterwards went to England to take command of an iron-clad. When prevented by the vigilance of the U. S. Minister he obtained a vessel at Copenhagen, which, however, was soon seized in Spain. He then removed to the Argentine Republic and engaged in cattle-farming. That government also employed him to superintend the construction of iron-clads in England. He resides at Florence, Italy. He published the narrative of his South American explorations in *La Plata* (1859).

His nephew, **THOMAS NELSON PAGE**, born in Hanover co., Va., April 23, 1853, has become noted as a writer of stories and poems in the negro dialect. He was educated at Washington and Lee University and is a lawyer at Richmond. His first story was *Marse Chun* (1884), and a collection of

them was published under the title *In Ole Virginny* (1887).

PAGE, WILLIAM (1811-1885), painter, was born at Albany, N. Y., Jan. 23, 1811. During his boyhood his parents removed to New York city, where he studied painting under S. F. B. Morse and at the National Academy. For a while he intended to enter the Presbyterian ministry, but his faith was shaken and he resumed his artistic pursuits at Albany. Then suddenly abandoning a projected visit to Europe, he married and settled in New York, where he became a member of the Academy in 1836. He achieved distinction in portrait-painting, but produced also historical pictures, a Holy Family, and the Infancy of Henri IV. For a while he resided in Boston, and in 1849 he went to Europe, where he found such attractions that he remained eleven years. He became intimate with the Brownings at Florence, and painted excellent portraits of Robert Browning and Miss Cushman. Other works of this period are Moses and Aaron on Mount Hor, The Flight into Egypt, and his famous Venus, representing the goddess guiding Æneas's fleet to Italy. In his brilliancy of coloring Page had become a rival of Titian; though he was still as from the first a disciple of Allston in spirituality. His natural gifts, careful study, and keen insight gave his works the highest value. After his return to New York in 1860 Page's fame as a portrait-painter became equal to that of Gilbert Stuart. He painted Lowell, President Eliot of Harvard, Henry Ward Beecher, Admiral Farragut, General Grant, and many more. From 1871 to 1875 he was president of the Academy of Design, and his lectures in art attracted much attention from his remarkable theories. While in Europe he found in the writings of Swedenborg a solution of the doubts which had harassed his mind since his early theological studies. These mystical views were blended with his theory of art. In his old age his intellect was clouded, and for ten years he did little work. While his studio was in New York his home was on Staten Island, and there he died Sept. 30, 1885. He had been thrice married and twice divorced.

PAINE, ROBERT TREAT (1731-1814), signer of the Declaration of Independence, was born at Boston, March 11, 1731. His father, Thomas Paine, had been pastor of a church at Weymouth, Mass., but afterwards became a merchant at Boston. Robert graduated at Harvard College in 1749, taught school, studied theology, and in 1755 became chaplain to the Northern provincial troops. He was admitted to the bar in 1759, and settled at Taunton, Mass. In 1770 he was counsel for the prosecution of Capt. Preston and others for the Boston Massacre. In 1773 he was chosen to the legislature, in 1774 to the Provincial Congress and also to the Continental Congress, where he was a member of important committees. In 1777 he was attorney-general of Massachusetts, and also a member of the executive council. In 1779 he took part in preparing the State Constitution, and soon after removed to Boston, where he held high position at the bar. He was a judge of the Supreme Court of Massachusetts from 1790 to 1804. He died at Boston, May 11, 1814.

His son, ROBERT TREAT PAINE, JR. (1773-1811), was born at Taunton, Mass., Dec. 9, 1773. While a student at Harvard College he became noted for his knack of versifying. When he graduated in 1792 he entered a counting-house but still spent his time chiefly in rhyming. He assisted in introducing "stage-plays" into Boston, and married Miss Baker, an actress. In 1794 he started *The Federal Orrery*, a paper whose personalities made him many enemies. The poem, *The Invention of Letters*, delivered on his taking his degree of A. M., in 1795, gave him wide celebrity which was enhanced by another in 1797 on *The Ruling Passion*, and still more in 1798 by his famous song, *Adams and Liberty*. Having removed

to Newburyport, he took up the study of law, and after his return to Boston was admitted to the bar in 1802. He had many literary projects which were cut short by his death at Boston, Nov. 13, 1811. His name was originally Thomas Paine, but on his petition to the Massachusetts legislature in 1801, pleading that this was no Christian name, he was permitted to assume that of his father. His writings were collected and published by Charles Prentiss in 1812.

PAINTING IN AMERICA. The branch of painting earliest practised in this country was naturally portraiture. Many of the paintings that have come down to us from the colonial period were, of course, brought over from Europe. But that painters, such as they were, were practising their art in the colonies as early as 1667, is shown by a passage in Cotton Mather's *Magnalia*. The earlier artists here were naturally foreigners, and were usually painters of no high order. But not a few who in their native land would have been barely accounted respectable artists, earned fame and money in the new land by transferring to canvas the faces of the colonial dignitaries.

The first artist of whom we have any record is John WATSON (1685-1768), a Scotchman, who came to America in 1715, settling at Perth Amboy, N. J. He painted several of the colonial governors, but none of his works are known at present. John SMYBERT (1684-1751), another Scotchman, is better known to us, as a number of his portraits are still extant. Bishop Berkeley engaged him as professor of the fine arts in his projected college in Bermuda. Smybert came to this country in 1829, and the Bermuda project proving a failure, he settled in Boston. Gulian C. Verplanck said of him: "Smybert was not an artist of the first rank, for the arts were then at a very low ebb in England, but the best portraits which we have of the eminent magistrates and divines of New England and New York who lived between 1725 and 1751 are from his pencil." His most important work is the group of Bishop Berkeley and his family, painted in 1731, which was given to Yale College in 1808. A copy of Vandyke, which he made in Italy, is said to have inspired several of our native American painters, notably Trumbull and Allston, with a love of art, and to have given them their first ideas of color. Smybert was followed by a swarm of foreign artists. BLACKBURN made a brief visit, Cosmo ALEXANDER, a Scotchman, came over in 1770, William WILLIAMS painted for a time in Philadelphia, John RAMAGE was painting miniatures in Boston in 1771, and so the list might be extended. The earliest native painter of merit of whom we have record is Robert FEEKE. He was painting portraits in Philadelphia about the middle of last century, and specimens of his work are in possession of Bowdoin College, the Redwood Athenæum, Newport, R. I., and the Rhode Island Historical Society. Next in date is Matthew PRATT (1734-1805), although his contemporaries, West and Copley, were earlier known as artists. Portraits like that of Cadwalader Colden, painted for the N. Y. Chamber of Commerce in 1772, attest his undoubted talent. He was remembered by many as an excellent painter of sign-boards, an occupation which he followed for some time. But the most noted painters of this period were John Singleton Copley and Benjamin West. COPLEY (1737-1815) had already established a reputation as a painter when he went to Europe in 1774. He went first to Italy, and thence to London, where he settled and became a member of the Royal Academy. In his portraits the dryness of tone and stiffness and formality of the figures have been objected to. He was a master in the rendering of stuffs, as is attested by the numerous specimens of his skill in portraiture in the Museum of Fine Arts, Boston, and at Harvard University. Many of his portraits are also in private collections in the United States. Of his numerous historical pictures, executed in England, the Death of the Earl of Chatham is the best known.

Benjamin WEST (1738-1820) was a successful portrait-painter in Philadelphia, at the age of 18. He went to Italy in 1760, and three years later to London, where he became the leading historical painter, was elected president of the Royal Academy, and enjoyed the king's patronage and protection for many years. He produced a very large number of historic and scriptural compositions, notably, *The Departure of Regulus*; *Death on the Pale Horse*; *The Death of Wolfe*; and *Christ Rejected*. There is in his works much that is conventional, and a certain brick-red coloring in them has been objected to. Yet West certainly possessed talent of a high order, and a thorough knowledge of the principles of his art. He showed moral courage, too, when, in painting the *Death of Wolfe*, he insisted, contrary to the advice of Reynolds, in clothing his characters in the dress of their time, repudiating the traditional custom of employing classical costume in all historic painting. He was withal a kind-hearted and benevolent gentleman, and had always a hearty welcome and good advice for the struggling young artists who came to him from his native land for instruction and assistance.

The next period, that of the Revolution, produced two painters whose names stand high in the list of American artists, Gilbert Stuart and John Trumbull. STUART (1755-1828) had his first art-instruction from the before-mentioned Cosmo Alexander, with whom he went to Scotland in 1772. He made several visits to Europe, and studied under West, in London, for several years. He returned finally to America, in 1793, and found ample employment for his brush. Of his large number of national portraits, the one of Washington, known as the "Athenæum head," is best known to the American public, although most critics consider it inferior to his first picture of Washington. His portraits are remarkable for color—to quote his daughter: "Color was one of Stuart's strong points." He was a master in the rendering of flesh tints, and gave his attention principally to the heads, in which he was most successful, slighting the figures and drapery, which, in some of his portraits, at least, are quite careless in execution. Excellent specimens of his works are owned by the Museum of Fine Arts, Boston, the New York Historical Society, and other institutions.

TRUMBULL (1756-1843), the son of Governor Jonathan Trumbull, of Connecticut (1710-1785), was educated at Harvard, and served with distinction in the war of the Revolution. He studied under West, in London, and later made several visits to Europe. He produced a number of portraits, including several of Washington, which, though perhaps unlike in details of feature, are usually spirited and lifelike in their general resemblance. It was in historical composition that his talents were conspicuous, and he yet stands alone in American historical painting. His most notable works are: *The Siege of Gibraltar*; *Declaration of Independence*; *Death of Montgomery*; and *Battle of Bunker Hill*. He was peculiarly fitted to depict the scenes in the history of the American struggle for independence. Himself prominent in public affairs, intimately acquainted with many of the prominent actors in his pictures, and thoroughly in sympathy with his subject, he produced a series of paintings which, in their line, are as yet unsurpassed in American art. In 1817 he received a commission from Congress for four historical subjects: *Declaration of Independence*; *Surrender of Burgoyne*; *Surrender of Cornwallis*; and *Resignation of Washington*. His later works are quite inferior to his earlier ones. His pictures were bequeathed to Yale College, where some of the best specimens of his skill may be seen.

Another well-known artist of this period was Charles Wilson PEALE (1741-1827). He was notable rather for his versatility than for extraordinary talents in any direction. Besides turning his mechanical talent to account in various ways, he acted as soldier, legislator, naturalist, and what not. His fame rests mainly on

his portraits, among which are several of Washington, who gave him, it is said, no less than fourteen sittings. Many of his pictures are in the Pennsylvania Academy and in Independence Hall, Philadelphia. Of the numerous members of his family who also chose art as a profession, his son Rembrandt (1778-1860) was the only one who achieved any works of real note. Among these is a good portrait of Washington.

Joseph WRIGHT (1756-93) and Edward SAVAGE (1761-1817) were also known as portrait-painters. William DUNLAP (1766-1839), like most artists of his time, tried his hand at a portrait of Washington. He is, however, better known as an author, and published in 1834 a *History of the Arts of Design in the United States*, now quite scarce. Col. Henry SARGENT (1770-1845) was an artist of repute in his time; and John Wesley JARVIS (1780-1840), an English portrait-painter, also enjoyed considerable popularity, as did later also Chester HARDING (1792-1866) and Edward G. MALBONE (1777-1807), whose miniatures are unsurpassed. Thomas SULLY (1783-1872) painted many prominent Americans, but was most successful in his female heads. His contemporary, John NEAGLE (1796-1865), is best remembered by his excellent full-length of Patrick Lyon, the blacksmith, painted in 1825. John VANDERLYN (1775-1852) also painted a number of portraits, but is best known by his *Marius Among the Ruins of Carthage*, and *Ariadne*, which latter, classic in style, is a very creditable work.

During all this initiatory period art in this country achieved its greatest successes in the department of portraiture and figure-painting. It was, furthermore, greatly under the influence of England. Now there gradually came a change, and the eyes of our art-students going abroad were turned towards Italy. Imitation of foreign art-methods was natural and, indeed, unavoidable. On the other hand there were various attempts made to found art-academies in New York and Philadelphia, culminating in the establishment of the Pennsylvania Academy and the New York Academy of Design. One of the leading representatives of the tendencies towards idealism, often false, that dominated much of our art, was Washington ALLSTON (1779-1843), a native of South Carolina. He studied under West, and lived for a number of years in Italy. His works aroused much enthusiasm, and his coloring won for him the name of "the American Titian." But, as is always the case with those overestimated in their time, there is now a tendency to underrate the work of Allston. Though not possessing genius of a high order, he was an artist of undoubtedly great talent, hampered, perhaps, by the want of encouraging influences in his native land. *The Dead Man Revived by Touching Elisha's Bones*; *Saul and the Witch of Endor*; *Spatatro's Vision of the Bloody Hand*; and *Jeremiah and the Scribe*, are among his works, in some of which he shows an unhealthy love for the terrible and supernatural. He also left an unfinished work, *Belshazzar's Feast*, now in the Museum of Fine Arts, Boston. John VANDERLYN, already mentioned, was a good classic painter, who won success while abroad, and gained a medal in Paris at the Salon of 1808. Samuel F. B. MORSE (1791-1872), better known in a totally different walk of life, was in the early part of his career an artist, practising both sculpture and painting. He composed a painting of the *Dying Hercules* from his statue of the same name. This work shows considerable anatomical knowledge. Morse was the first president (1826-42) of the National Academy of Design.

Among the portrait-painters of this period were: Samuel L. Waldo (1783-1861) and William Jewett (b. 1795), who painted in partnership; William E. West (1788-1857); Charles C. Ingham (1797-1863); Henry Inman (1801-46); Charles Loring Elliott (1812-68); George P. A. Healy (b. 1813); William Page (1811-85); W. H. Furness (1828-67); Thomas Le Clear (1818-82); George A. Baker (1821-80);

Thomas P. Rossiter (1817-71); Joseph Ames (1816-72), and Richard M. Staigg (1817-81), noted for his miniatures, in which department Thos. S. Cummings also worked. One of the strongest of the lot was Elliott, who was especially successful in the rendition of character. Page experimented much in color, striving especially to discover Titian's method of painting. Daniel Huntington, Thomas Hicks, and Geo. H. Yewell have also produced notable works in portraiture.

Another change becomes noticeable towards the middle of this century, for Düsseldorf and Munich began to claim a share in shaping our national art. Emmanuel LEITZE (1816-68) is one of the most prominent artists of this period. A German by birth, he was brought to America as an infant. Although his art-education was received in Düsseldorf, he showed an extraordinary love for American subjects. Among his more important paintings are, Washington Crossing the Delaware; Washington at the Battle of Monmouth; Washington at Valley Forge; and Westward the Star of Empire Takes its Way, the last in the Capitol at Washington. A number of other painters during this period gave more or less attention to historic subjects, but little worthy of note was accomplished in this direction. Edwin WHITE (1817-77), who studied at Paris and Düsseldorf, painted some American historic pieces, notably Washington Resigning his Commission. He was exceedingly prolific, most of his works dealing with European subjects. Peter F. ROTHERMEL has produced some works illustrative of American history, among which is the Battle of Gettysburg. John G. Chapman, well known as an illustrator and *genre* artist, also aspired to this difficult field of painting, as did also John Blake WHITE (1781-1859). William H. POWELL (1823-79) is known best by his De Soto discovering the Mississippi, in the Capitol at Washington. Christian SCHUSSELE (1824-79), an Alsatian, was for some years director of the schools of the Pennsylvania Academy, in which capacity he exercised a certain influence on our art. His *Clear the Track*, *Men of Progress*, *The Iron Worker* and *King Solomon*, and other works, became widely known through the prints by John Sartain and other engravers. Thomas P. ROSSITER (1817-71) painted many historical and scriptural subjects, and Robert W. WERT is known as the painter of the *Sailing of the Pilgrims*, and similar works, pleasing in style, although not strikingly original.

In the department of *genre* our artists had, until now, made but few attempts. Charles Robert Leslie and Gilbert Stuart Newton can hardly claim a place here, as they are so closely identified with the art of England. Henry INMAN (1801-46), known best by his excellent and characteristic portraits, executed some *genre* pictures, but the most important *genre* painter of the period was William Sidney MOUNT (1807-68). His works were thoroughly national in spirit; no one has so well delineated the humorous side of the life of the American farmer; and the negro, too, figured frequently in his compositions. As a colorist he was not remarkable, but his pictures show a shrewd observation of human nature. F. W. EDMONDS (1806-63) produced some clever pictures of American subjects, and Richard Caton WOODVILLE (c. 1825-1855), who studied at Düsseldorf, became well known through his *Mexican News*, *Sailor's Wedding*, etc., but was unfortunately cut short in his career when but 30 years of age. Our Indians and trappers found delineators in George CATLIN (1796-1872), Charles Deas, and William RANNEY (1813-57).

To come down to the *genre* art of a later date, John B. IRVING (1825-77) was noted for his spirited execution and elaborate finish, and Frank B. MAYER (b. 1827) also won distinction in this line. John F. WERT has executed some vigorous paintings, like *Forging the Shaft*, and Seymour J. Guy has given us some charming pictures of child-life. Two of our best-known *genre* artists are Thomas W. WOOD and John G.

BROWN. The former frequently chooses scenes in rural life, and has also produced numerous characteristic pictures of negro subjects. Mr. Brown has come to be considered mainly as the painter *par excellence* of our news-boys and boot-blacks, whom he often brings before us in characteristic positions. Others more or less known in the department of figure-painting are Benjamin F. Reinhart (1829-85); John W. Ehninger; Constant Mayer; Edward H. May (1824-87); Alfred C. Howland; E. Wood Perry; Lemuel E. Wilmarth; Geo. W. Flagg; Cephas G. Thompson; Jerome Thompson; E. L. Henry; W. J. Hennessy; P. P. Ryder; Robert Wylie (d. 1877); Thomas Hovenden; Walter Satterlee; E. M. Ward; Julian Scott; Henry Mosler; J. W. Champney, and William Magrath. Daniel Huntington, better known as a portrait-painter, has executed graceful and pleasing figure-pieces. George Fuller, Henry A. Loop, and F. S. Church represent the ideal element among our figure-painters. Geo. H. Boughton excels in Puritan subjects, Eastman Johnson has produced effective work in the delineation of negro life and domestic scenes, and A. Wordsworth Thompson has given us some good historical compositions.

In our landscape art we for the first time find decided originality, and a national feeling which foreign influences did not suppress. Our landscape artists, although occupied at times also with European subjects, show in their works a notable preference for the scenery of their own country. The Catskills, the White Mountains, Hudson River, Lake George, and later the Rocky Mountains and the Yosemite Valley, have furnished subjects for innumerable paintings.

Joshua SHAW (1776-1860), an English artist who came over about 1817, was apparently the first in this country to make a specialty of landscape. But Doughty, Cole, and Durand are generally regarded as the pioneers in this branch of art. Thomas DOUGLASS (1793-1856) left the leather business at the age of twenty-eight to take up landscape-painting, and he followed with much success the art which he had adopted with so little preparation. Thomas COLE (1801-48), born in England, came to this country at the age of eighteen, and received his first training here. He later studied for some time in Italy, and his work shows distinct traces of the influence of Salvator Rosa and Claude. The works by which he is best remembered are his allegoric landscapes, especially his *Course of Empire*. Regarded simply from an art point of view, his paintings show faults, yet there is in them a moral intent and purpose and a dignity and grandeur which have secured for him a high place among his contemporaries. He undoubtedly, too, had a lasting effect on our landscape art. Asher B. DURAND (1796-1886) had gained an enviable reputation in other branches of art before he took up landscape-painting. As a steel-engraver, he employed his burin in producing such admirable plates as Vanderlyn's *Ariadne* and Trumbull's *Declaration of Independence*. Next he practised portrait-painting with success, and finally, at the age of thirty-eight, he directed his efforts to landscape art. The care he had found it necessary to exercise as an engraver was carried into his new vocation, and his landscapes, though faithful in detail, are yet broad and effective. He excelled especially in rendering the individuality and characteristics of trees, and produced occasionally successful atmospheric effects.

One of the most prominent of the landscape-painters who followed was John F. KENSETT (1818-73), who, like Durand, began his career as an engraver. He passed a number of years abroad in study, and after his return produced many faithful delineations of the scenery of his native land. His paintings are good in technique, broad in treatment, excellent in color, and show much poetic feeling. George L. BROWN (b. 1814) was somewhat under the influence of Italy, and much of his work deals with the scenery of that country. His paintings are effective and brilliant in tint and color, but he belonged to a school which at times, perhaps,

somewhat slighted nature. Worthington WHITTREDGE was among those who studied at Düsseldorf, when that school was first introduced as an influence into our art. He is a close student of nature, and although for technique he doubtless owes much to foreign training, yet his work is thoroughly individual, and shows but few traces of foreign influence. John W. CASILEAR, like Durand and Kensett, was at first an engraver, and later abandoned the burin for the brush. His elaborate landscapes, though not distinguished for originality, are refined and delicate. James A. SUYDAM's tender landscapes were characterized by somewhat similar qualities. Jasper F. CROUSEY, though somewhat crude at times, has had more or less success in reproducing the vivid coloring of our autumnal scenery, and R. W. Hubbard's simple, harmonious compositions have been praised by more than one critic as veritable poems. T. Addison Richards, C. P. Cranch, A. H. Wenzler, Martin J. Heade, David Johnson, J. R. Meeker, John B. Bristol, Wm. Russell Smith, Charles H. Miller, Aaron D. Shattuck, Wm. L. Sonntag, H. W. Robbins, John R. Tilton, A. H. Wyant, James B. Sword, Kruseman Van Elten (a Dutchman by birth), J. R. Brevoort, Geo. Q. Thorndike, R. H. Fuller, A. Wordsworth Thompson are among the other artists who have gained repute in the department of landscape. To these should be added those whose reputation dates from more recent times, and most of whom are quite in sympathy with the art-tendencies of to-day; men like Samuel Coleman, F. H. Shapleigh, F. D. Williams, R. M. Shurtleff, J. Foxcroft Cole (a pupil of Lambinet, and good in color), W. A. Gay, J. A. Brown, James D. Smillie, Geo. H. Smillie, Arthur Parton, J. C. Nicoll, F. Hopkinson Smith, Henry Farrar, John J. Enneking, Frank Waller, D. W. Tryon, H. Bolton Jones, Wm. S. Macy, Bruce Crane, A. F. Bunner, J. H. Twachtman, Joseph Lyman, Carleton Wiggins, Julian Rix, J. Francis Murphy, E. Gay, Harry Fenn, G. H. McCord, and C. A. Platt.

In Frederic E. CHURCH we have a good representative of the school whose work is mainly objective in character. He unites carefulness in detail to breadth of treatment in general. Tropical scenes form the subjects of many of his paintings, but the general public knows him best, perhaps, as the painter of the grand and impressive picture of Niagara. He is a careful, scientific student of nature, whose pictures, it has been said, are good illustrations of the physical geography of the countries in which he has travelled. Louis R. MIGNOT (1831-70) also showed a preference for tropical subjects, which he painted with a fine feeling for color, and Sanford R. GIFFORD (1823-80) had a true eye for striking and phenomenal atmospheric and light effects.

Three landscape-artists, Bierstadt, Hill, and Moran, are specially prominent as having first delineated for us the grand scenery of the West. Albert BIERSTADT, born in Düsseldorf, came to America in infancy and subsequently went back to his native city to study art. After his return to the United States he accompanied Gen. F. W. Lander's exploring expedition in 1858, and made the studies for his paintings of Rocky Mountain scenery. His Rocky Mountains, which created a *furor* in its day, is, however, not a picture of any actual scene, but a typical composition. Bold in treatment, and frequently ambitious in design, his paintings seem at times to show an undue degree of striving after effect. An artist of undoubtedly great originality and power, he is, like Leutze, a true representative of the Düsseldorf school, the merits as well as defects of which characterize most of his works. His earlier paintings, especially, aroused unbounded enthusiasm, and he has received various honors at home and abroad. Thomas Hill has produced some bold and effective paintings of California scenery. One of his pictures deals with the Yellowstone, a subject that has also employed the pencils of Bierstadt and Thomas MORAN. The latter artist's

fine painting of the Grand Cañon of the Yellowstone is in the Capitol at Washington. Moran is an exceedingly clever painter, possessed of a vivid imagination, and well versed in the technique of his calling. Though undoubtedly influenced by his attention to the methods of Turner, his works show him also to be an assiduous and careful student of nature.

The brothers William and James M. HART, both born in Scotland, have also gained an honorable place among our landscape-painters. The younger, James, has introduced cattle into many of his later pictures, with considerable success. Albert F. BELLOWES (1829-1883), who studied in Antwerp and Paris, first became known as a *genre* painter, but later turned his attention to landscape. He was one of the early members of the Water-Color Society, and painted much in water-colors. This medium had not been seriously used by our artists before 1865. In that year a collection of English water-colors was exhibited in New York, which attracted much attention, and seems to have done considerable towards stimulating our artists to turn their attention more to the culture of water-color painting. Their success in this direction was rapid, as is attested by the works of Bellows, W. T. Richards, Henry Farrar, H. W. Ranger, and others.

A leaning towards a more subjective style of landscape-painting, as distinct from the purely objective method that dominated so much of our landscape art, is found in the works of Jervis MCENTEE, who has striven to represent on canvas the sentiments suggested by certain phases of our autumnal scenery, Homer D. Martin, and others. In some of the earlier works of George INNESS there is a tendency to make a careful reproduction of details the first consideration. But his emotional nature caused him soon to adopt a broader style, and a less objective method. His principle became, as he said himself, to reproduce for others such impressions as a scene called forth in his own mind. Though his pictures are unequal in merit, the best of them are impressive, excellent in light and color, and in atmospheric effects. R. Swain GIFFORD, like Inness, has been influenced more or less by the art of France, and is also one of those artists who always leave an impression of his feelings and emotions upon his work. His earlier efforts were in the direction of coast scenes, but he later devoted himself to landscape, and his travels and observations abroad have served but to broaden his style.

In marine painting but little was produced until lately, and that little by foreigners. Thomas BIRCH (died 1851) followed this branch of art in Philadelphia, painting especially naval engagements, while another early marine-painter, Salmon, practised his art in Boston. A. VAN BEEST (*d.* 1860), a Dutch artist, won a certain reputation in this line, and John E. C. PETERSEN (1839-74), a Dane, who came to this country in 1865, settling in Boston, was an artist of considerable talent. But perhaps the best of our earlier marine painters was James HAMILTON (1819-78), a native of Ireland, who established himself in Philadelphia. His best-known pictures include *Capture of the Serapis*; *Old Ironsides*; and such weird and phantastic productions as the *Ship of the Ancient Mariner*. They show a strong contrast of subjects, much imaginative power, and a bold and effective style. Bradford and Dix were among the earliest of our artists to cultivate this branch of art. Charles Temple DIX (1838-73), a son of Gen. John A. Dix, produced some promising work, but unfortunately died young. William BRADFORD, of Quaker origin, has painted effective pictures of the coast scenery of the Eastern States, but is known especially through his studies in Labrador, and his paintings of its scenery and icebergs. Edward MORAN, a brother of Thomas, already mentioned, studied under James Hamilton. He is a marine-painter of repute, and has successfully introduced the human figure into some of his paintings. William T. Richards was at first a decided Pre-

Raphaelite, but later acquired greater freedom of handling. Of late years his attention has been directed especially to the painting of marine and coast views. His excellent water-colors show the same careful finish which characterizes his work in oil. W. E. NORTON has shown his talents in compositions like the *Fog Horn* and *Crossing the Grand Banks*, and Arthur QUARTLEY (1839-86), who was originally a sign-painter, succeeded, though self-taught, in placing himself in a few years in the front rank of our marine-painters. Alfred T. BRICHER has produced some fresh and vigorous coast-scenes, and J. C. NICOLL has worked in this field, but like Bricher paints also landscapes. He has more poetic feeling than that artist, however. Francis A. Silva, Frank K. M. Rehn, Wm. P. W. Dana, Harry Chase, R. C. Coxe, and S. S. Tuckerman are also favorably known to the public. J. O. Davidson and M. J. Burns have given much attention to book-illustration. One of the most prominent among our marine-painters of to-day is Maurice F. H. DE HAAS, who was court-painter in Holland before he came to America in 1859. His pictures, though broad, are yet sufficiently finished in detail, and a number of strong and brilliant compositions have come from his easel. He has probably had influence on our marine art.

Coming now to animal-painting, we find that in this department our art has not produced much that is noticeable. As a scientific ornithological painter, John J. AUDUBON (1780-1851) held high rank. T. H. HENCKLEY was one of our earliest cattle-painters, but never advanced beyond his first, really promising, attempts. Henry C. Bispham produced some spirited cattle-pieces. William J. HAYS (1830-75) devoted himself with some success to the delineation of the animal world of the western prairies, and Alfred G. Miller painted similar subjects. Arthur F. TAIT, an English artist who has settled in this country, is well known to the public, many of his works having been lithographed and widely circulated. Walter M. Brackett and Gurdon Trumbull are among those who have made the painting of fish a specialty. William H. BEARD has gained a reputation through his pictures of bears and monkeys, in which the weaknesses and foibles of humanity are reflected with caustic satire. His brother, James H. Beard, has also won a respectable position as an animal-painter, as has also his nephew, James Carter Beard, although the latter has devoted himself more especially to book-illustration. Peter MORAN, the third of this artist-family, has been successful in painting sheep and cattle, and James Hart, as has been remarked before, is also favorably known for his cattle-pieces. Thomas Robinson, George Inness, Jr., and J. Ogden Brown have also worked in this field. Miss Fidelity BRIDGES is known by her charming pictures of bird-life. Frank Rogers has had some success in painting dogs, and Henry R. Poore has also produced some good work in this department. R. M. STURTELEFF, known best as landscape-painter, has introduced deer and other wild beasts into some of his paintings of forest scenery.

In the department of still-life, Raphaelle PEALE, a son of C. W. Peale, was probably the first to practice. George H. Hall (1826-88) and A. J. H. Way have both earned a reputation through their paintings of fruit-pieces. H. W. Parton has been very successful in some of his paintings of flowers, as has also Ellen Robbins. In fact, a large number of ladies have enjoyed a certain degree of success in this department. William W. HARNETT has produced some still-life pieces almost photographic in their truth to nature. John LAFARGE'S ideal and brilliant flower-pieces have been much admired. It is as a colorist that he excels, and he has given much attention to decorative art, in which department he has produced some excellent work, notably in Trinity Church, Boston. Francis LATHROP has also distinguished himself in this direction.

Elihu VEDDER has striven to express his emotions

and impressions in his works. Works like the *Lair of the Sea Serpent* have especially aroused much criticism as to their deeper intent and purpose. Vedder is an artist of undoubted strength, who has shown great imaginative power in his paintings, and in his powerfully drawn illustrations to the *Rubaiyat of Omar Khayyam*.

In entering upon the present period of our country's art-development, we find a new force exerting itself, new influences making themselves felt. The influence of France is now manifest. Our art has again made a step in advance. A growing discontent with old methods and conventionalities has found expression to a certain degree in the founding of societies like the American Art Association and the Art Students' League.

William M. HUNT (1824-79) did much to further the cause of American art, and partly by introducing the new art methods practised in France. He studied for a short time at Düsseldorf, and then went to Paris, where he became a pupil of Couture, and was furthermore influenced by J. F. Millet, whose art-methods he was one of the first to discover and to emulate. He worked in genre, portraiture, landscape, and decorative painting, a notable example of his work in the last department being *The Flight of Night* and *The Discoverer*, in the capitol at Albany. In the works of some of the artists already mentioned in this sketch, a leaning towards the progressive spirit of the new movement makes itself strongly felt. Of our figure-painters of to-day, two, especially, have had a most decided influence on our art—Walter STIRLAW and William M. CHASE, both of whom have been instructors in the Art Students' League. Trained in the school of Munich, Stirlaw has an excellent technical knowledge, paints broadly, and has decided feeling for color-values. One of his most important works, *Sheep-shearing in the Bavarian Highlands*, has been favorably received at home and abroad. Chase has been particularly successful in the painting of single figures like *The Apprentice*, *Waiting for the Ride*, etc., in which he shows a fine sense of color. He has also produced some characteristic portraits. Many of our "younger men" show in their works a thorough sympathy with the present tendencies of our art. Frank Duveneck, William Sartain, Robert Kochler, J. Alden Weir, Winslow Homer, Louis C. Tiffany, A. H. Thayer, A. P. Ryder, Wyatt Eaton, David D. Neal, F. P. Vinton, E. L. Weeks, Henry Bacon, William H. Muhrman, F. A. Bridgman, George Inness, Jr., William Dannat, Geo. W. Maynard, F. D. Millet, E. H. Blashfield, Charles S. Pearce, J. C. Beekwith, T. W. Dewing, Gilbert Gaul, A. Kappes, Hamilton Hamilton, C. F. Ulrich, I. R. Wiles, C. Y. Turner, Robert Blum, Kenyon Cox, H. S. Mowbray, George de Forest Brush, C. C. Curran, Louis Moeller, Fred. Dielman, are among those identified with the new art movement. To these should be added nearly all of the younger landscapists mentioned previously in this article. In realistic portraiture some excellent results have been achieved by Eastman Johnson, Moses Wight, B. C. Porter, J. A. Weir, Thomas Eakins, and John S. Sargent. J. A. M. WHISTLER, who has for many years lived in London, is known chiefly for his experiments in color, and his skill in etching. Will H. Low, Edwin A. Abbey, and Charles S. Reinhart, although they have worked with much success in color, have been more prominent in the department of book-illustration.

As one critic has observed, this new movement should be regarded not so much as an attempt at reform, but simply as another step in advance, another stage in the progress of art in this country. It can, of course, not be said that all the qualities of good art are united in the methods of this new school. With the great advance in technical knowledge there has come in also an undue leaning towards ultra-realism. It remains for the succeeding generation of artists to modify many of these aims and principles, and to raise American art to a still higher level. (F. L. W.)

PALEY, FREDERICK APTHORP, an English classical scholar, was born at Basingwold, near York, England, in 1816. He is a grandson of Rev. William Paley (1743-1805), the celebrated author of *The Evidences of Christianity*, for whom see the *ENCYCLOPÆDIA BRITANNICA*. Frederick graduated at Cambridge in 1838, and was tutor there until 1846, when he became a Roman Catholic. He then retired to London, where he edited with great ability Æschylus, Sophocles, Euripides, Hesiod, Theocritus, and other classics. He translated into English the tragedies of Æschylus and the odes of Pindar. He was a friend of Pugin and in early life gave much attention to Gothic architecture. His *Manual of Gothic Mouldings* has passed through several editions. He also published *A Manual of Gothic Architecture* and essays on kindred subjects, and *Greek Wit*, a collection of sayings and stories from the Greek prose-writers.

PALFREY, JOHN GORHAM (1796-1881), historian, was born at Boston, May 2, 1796. His grandfather, Col. William Palfrey (1741-1780), was paymaster-general of the Revolutionary army, and was lost at sea while on his way to France as consul-general. John graduated at Harvard College in 1815, and became minister of Brattle Street (Unitarian) Church in 1818. He was Dexter professor of sacred literature in Harvard College from 1831 to 1839, and edited the *North American Review* from 1836 to 1843. He was a member of the Massachusetts legislature in 1842, and secretary of state from 1844 to 1847. In 1846 he published in the *Boston Whig* a series of articles on "The Progress of the Slave-Power." In 1847 he was elected to Congress as an anti-slavery Whig but served only one term. He was defeated as candidate for governor in 1851, and then retired from public life, devoting himself to literature. He was called forth again in 1861 to become postmaster of Boston, which office he held five years. He died at Cambridge, Mass., April 26, 1881. Besides a History of the church to which he had ministered, and a biography of his grandfather, he published his lectures on *The Jewish Scripture and Antiquities* (4 vols., 1833-52), on *The Evidences of Christianity*, and on the *Relation between Judaism and Christianity* (1854). His most noted work is the *History of New England*, of which three volumes appeared (1858-64), bringing the work down to 1688, the end of the first cycle in the author's division. He then abridged this work into two volumes (1866) and afterwards continued the abridged edition in two more volumes (1872-73), bringing the history down to 1765. His work is written with force, dignity, and impartiality, and gives a faithful picture of the toils and struggles of the people of New England in founding a virtuous republic.

His son, **FRANCIS WINTHROP** PALFREY, born April 11, 1831, graduated at Harvard in 1851, and studied law. In the civil war he served as lieutenant-colonel of a Massachusetts regiment, and was severely wounded. He has published *Antietam and Fredricksburg* (1882) and some other volumes.

PALGRAVE, FRANCIS TURNER, an English poet, was born at London, Sept. 28, 1824. He was the son of Sir Francis Palgrave (1788-1861), the historian of Normandy, for whom see the *ENCYCLOPÆDIA BRITANNICA*. He was educated at the Charter house School and at Balliol College, Oxford, where he graduated in 1844. He was chosen a fellow of Exeter College, and was afterwards vice-principal of a training school at Kneller Hall for five years. He was long employed in the educational bureau of the Privy Council. He has been both author and editor of lyric poems and hymns. His works comprise *Idyls and Songs* (1854); *Hymns* (1867); *Lyrical Poems* (1871); and some publications on art. His collection called *The Golden Treasury of English Lyrical Poetry* (1861) is deservedly famous. He was appointed professor of poetry at Oxford in 1886.

His brother, **WILLIAM** GIFFORD PALGRAVE, was

born at Westminster, Jan. 24, 1826. He was educated at the Charter house and at Trinity College, Oxford, where he graduated in 1846. He was an officer in the Indian army until 1853, when he entered the Roman Catholic Church. Becoming a Jesuit, he studied theology at Laval, France, was ordained a priest and sent as a missionary to Syria. Having become well versed in Arabic and in Mohammedan theology, he went in 1862 in the disguise of a physician through the Wahabite kingdoms of Central Arabia. After his return to Europe in 1863 he left the order of the Jesuits. In 1865 he went to Abyssinia to procure the release of the British prisoners held by King Theodore. He was appointed British consul at Souk-houni-Kalé in 1866, at Trebizond in 1867, at St. Thomas, West Indies, in 1873, at Manila in 1876, and consul-general to Bulgaria in 1878, and to Siam in 1880. He has published *A Year's Journey through Central and Eastern Arabia* (1865); *Essays on Eastern Questions* (1872); *Hermann Aghu* (1872); *Alkamah's Cave* (1875); *Dutch Guiana* (1878).

PALMER, BENJAMIN MORGAN, Presbyterian minister, was born at Charleston, S. C., Jan. 25, 1818. He graduated at the University of Georgia in 1838, and at Columbia Theological Seminary in 1841. He was then ordained pastor of the First Presbyterian Church, Savannah, but two years later accepted a call to a pastorate in Columbia. Here he was also a director of the Theological Seminary, and from 1853 to 1856 was its professor of church history and polity. In 1856 he became pastor of the First Presbyterian Church in New Orleans. He assisted in founding the *Southern Presbyterian Review* in 1847, and has since been one of its editors. He earnestly supported the secession movement and the Confederate cause. In 1861 he was moderator of the first General Assembly of the Southern Presbyterian Church at Augusta, Ga. He published *Life and Letters of J. H. Thornwell* (1875); *The Family in its Civil and Churchly Aspects* (1876); and some volumes of sermons.

PALMER, ERASTUS DOW, sculptor, was born in Onondaga co., N. Y., April 2, 1817. He was a carpenter at Utica, N. Y., for several years, but in 1846 settled at Albany and engaged in cameo-cutting. Finding this occupation injurious to his sight he turned to sculpture, being now thirty-five years of age. His first work was *The Infant Ceres*, modelled from one of his own children. He then made bas-reliefs, *The Morning Star*, *The Evening Star*, *Resignation*, *Peace in Bondage*. Among his full-length figures are *An Indian Girl Finding a Crucifix*, *The White Captive*, and *The Emigrant's Children*. For the Capitol at Washington he made, in 1857, a group of sixteen figures, representing *The Landing of the Pilgrims*, but it was placed in the pediment for which it was designed. Palmer has also made portrait busts of Com. M. C. Perry, Washington Irving, Gov. E. D. Morgan, and others. He did not visit Europe until 1873, when he spent some time in study at Paris. His statue of R. R. Livingston obtained a first-class medal at the Centennial Exhibition. His conceptions are highly poetic, and are wrought out with strict regard to nature. Several of his best works are ideal medallions.

His son, **WALTER LUNT** PALMER, born at Albany, Aug. 1, 1851, studied art in Paris, and settled at New York in 1877, devoting himself chiefly to landscape-painting. In 1882 he removed to Albany. Among his works are *An Editor's Study* (1880); *Venice* (1882); *The Oat-Field* (1884); *January* (1887).

PALMER, JAMES CROXALL (1811-1883), surgeon-general U. S. navy, was born at Baltimore, Md., June 29, 1811. He graduated at Dickinson College in 1829 and studied medicine in the University of Maryland. In 1834 he entered the naval service as assistant-surgeon, and within a year sailed around the world. In 1838 he joined Wilkes's exploring expedition and encountered various perils in the Antarctic regions.

His vessel being wrecked at the mouth of the Columbia River in 1841, he spent some months on shore in scientific work. He was commissioned surgeon on his return to New York, and soon after had charge of the numerous wounded by the explosion on board the U. S. steamer Princeton. He served off the coast of Mexico during the war with that country, afterwards in the Pacific, and on the steam-frigate Niagara during the first attempt to lay the Atlantic cable. At the outbreak of the civil war he took medical charge of the naval academy then removed to Newport, R. I. In 1863 he joined Admiral Farragut's blockading squadron, and he was attached to the flagship Hartford during the battle of Mobile Bay. At the close of the war Dr. Palmer returned to the North with health greatly impaired, but had charge of the naval hospital at Brooklyn for four years. He was commissioned as medical director in March, 1871, and as surgeon-general in June, 1872, but retired a year later. He died at Washington April 24, 1883.

His brother, JOHN WILLIAMSON PALMER (1825-1874), was born at Baltimore April 4, 1825. He graduated at the University of Maryland in 1847, studied medicine, and became city physician in San Francisco in 1851 and surgeon in the East India Company's service in the Burmese war. His graphic sketches of life in California and India were published in *Putnam's Monthly* and the *Atlantic Monthly*. During the civil war he was a Confederate war correspondent of the *New York Tribune*. After the war he was a physician in Baltimore, but in 1870 removed to New York. Among his books are *The Golden Dagon* (1853); *New and Old* (1859); *Folk-Songs* (1860), and some novels and art-books.

PALMER, JOHN McCAULEY, general, was born at Eagle Creek, Scott co., Ky., Sept. 13, 1817. Having removed to Illinois during his youth, he became a lawyer at Carlinville and was elected to the State Senate in 1852-4. He took part in the formation of the Republican party and was presidential elector on its ticket in 1860. In April, 1861, he became colonel of the Fourteenth Illinois volunteers and was engaged in Missouri. He was made brigadier-general of volunteers in December, and took part in the capture of New Madrid. His gallantry at the battle of Stone River, Jan. 1-3, 1863, where he commanded a division, secured his promotion to major-general. He fought at Chickamauga and commanded the Fourteenth corps in the Atlanta campaign. When Gen. O. O. Howard was promoted to the command of the right wing of Sherman's army, on the death of Gen. McPherson, Gen. Palmer, who thought himself entitled to the position, asked to be relieved, and was assigned to the command of the department of Kentucky. He was governor of Illinois from 1869 to 1873.

PALMER, RAY (1808-1887), hymn-writer, was born at Little Compton, R. I., Nov. 12, 1808. He graduated at Yale College in 1830 and engaged in teaching. In 1832 he was licensed to preach in the Congregational Church, and he was pastor of the Central Church, Bath, Maine, from 1835 to 1850. He was then called to the First Congregational Church, Albany, N. Y., and was its pastor until 1866, when he became secretary of the American Congregational Union in New York city. During the twelve years of his secretaryship the society assisted in erecting over 600 church buildings. Dr. Palmer was, during the same period, one of the visitors of Andover Theological Seminary, and was engaged in literary work. In 1878 he retired to Newark, N. J., where he died March 29, 1887. Dr. Palmer is best known as the author of the hymn, "My Faith looks up to Thee," which has been translated into more than twenty languages. Others of his hymns have been widely used. His *Complete Poetical Works* were published in 1876. He also published *Chapel Hours* (1851); *Home, or the Unborn Paradise* (1868); *Voices of Hope and Gladness* (1880).

PALMETTO is the representative form taken by the palm within the limits of the United States, and probably the most hardy of the palms, since it extends northward as far as the latitude of North Carolina. Two genera and four species of palmetto exist in the region between North Carolina and Florida, the most important of these being *Sabal Palmetto*,



Palmetto Palm.

the cabbage palmetto, a noble palm, which sometimes attains a height of 50 ft. and a diameter of 12 to 15 in. It is crowned with a circlet of fan-shaped leaves of about 5 ft. in length and breadth and having long footstalks. The flowers are small, greenish, and in long racemes, with cup-shaped calyx and 3-petalled corolla, 6 stamens, and a 3-celled ovary. The fruit is a 1-seeded drupe, black, oblong, 4 to 5 in. in length, and not eatable.

This species receives its local name from the cabbage, or circle of unexpanded leaves, which forms one of the most delicious of table vegetables.

The cabbage palmetto is found on the sandy coast regions from Florida to North Carolina, and also occurs in the Bermudas. Its wood is very porous, but is almost imperishable under water, and is not attacked by the teredo. Hence it is much esteemed for wharf-building. The original Fort Moultrie, whose spongy wood received the balls of the British guns without injury, was built of palmetto logs. The leaves are used in the manufacture of hats, baskets, mats, and for various domestic purposes. The root is highly astringent and has been proposed as a tanning material.

The other species of palmetto are of minor importance. *S. serrulata*, the saw palmetto, has a low creeping stem, 4 to 8 ft. long, with bright-green, fan-shaped leaves, which are of use in hat-making. It occurs on the sandy coast soil from South Carolina to Florida.

S. Adansoni, the dwarf palmetto, is destitute of a stem, sending up above the ground only a circlet of fan-shaped leaves, 2 to 3 ft. long. It covers dense patches of ground in the low coast regions from North Carolina to Florida, growing well in marshy places.

Chamærops hystrix, the blue palmetto of Florida and South Carolina, is a hardy dwarf fan palm, with long-petioled, fan-shaped leaves. It grows in shady woods, and is remarkable for the needle-like thorns which, like porcupine quills, grow from the root mingled with the leaves. From these the specific name is taken. The roots of the palmetto are so numerous and strong in some soils as to make plowing difficult and expensive. (C. M.)

PANCOAST, JOSEPH (1805-1882), an eminent surgeon, was born in Burlington co., N. J., in 1805. He obtained his degree at the University of Pennsylvania in 1828, and began teaching practical surgery in 1831. He was connected with the Philadelphia Hospital from 1834 to 1845 and with the Pennsylvania Hospital from 1854 to 1864. He was elected professor of surgery in the Jefferson Medical College in 1838, and in 1847 exchanged this position for the professor-

ship of anatomy. Resigning in 1874, he was succeeded by his son, Dr. William H. Paneoast (born Oct. 16, 1835). He was noted for his bold and successful surgical operations, and introduced many improvements which have been adopted by other surgeons. He was especially successful in rhinoplasty, in removal of tumors, and in amputations at the hip-joint. For the latter he devised an abdominal tourniquet. He died at Philadelphia March 7, 1882. He published a *Treatise on Operative Surgery* (1844) which passed through several editions, and revised Wistar's *System of Anatomy* and other works. He also contributed frequently to the *American Journal of the Medical Sciences* and other professional periodicals.

PAPAW (Malay *papaya*), the fruit of *Carica papaya*, a small South American tree, whose fruit, though not very palatable, is eaten. The root of the papaw tree has an offensive odor, and the juice of the fruit, before ripening, contains a remarkable albuminous substance resembling fibrine. This plant is said to have the property of rendering meat tender. Newly killed meat hung among the leaves becomes soft and delicate, and the flesh of hogs and poultry fed on its leaves or fruit becomes remarkably tender.

The name of papaw is also given to *Asimina triloba*, a North American tree of from 10 to 20 ft. in height, and to several smaller species of *Asimina*. The roots

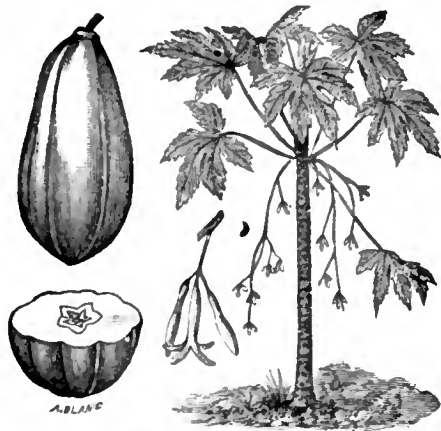

The North American Papaw.

and bark of these trees have an extremely nauseous odor. The ripe fruit is about 3 in. long by 1½ in. thick, of yellowish color and irregular oval form. The pulp is soft and insipid, containing several large seeds. It has no marketable value, though eaten to some extent. The tree grows in the sandy regions of Georgia and Florida. (C. M.)

PAPER. This article is confined to the manufacture of paper in America. The development of the paper-making industry of the United States as to most of its details is of comparatively recent growth, but not the less noteworthy and remarkable. The first paper-mill in North America was established in 1690 by William Rittinghuysen, whose descendants, under the name of Rittenhouse, perpetuate this Dutch patronymic. Rittinghuysen, associating himself with William Bradford, the Philadelphia printer, built his mill in Roxborough, on Paper-mill Run, near the Wissahickon Creek, and about 2 miles from the Schuylkill River. This locality is now included within the limits of the city of Philadelphia. Twenty years later (1710) the second paper-mill in America was built in Germantown (now also a part of Philadelphia) by William DeWees. The third paper-mill was also started in Pennsylvania in 1728, and in 1730 the first mill in New England was opened at Milton, Mass. By 1770 forty mills were in operation in Pennsylvania, New Jersey, and Delaware; while in 1775, at the out-

break of the Revolution, only four are on record as being located in New England. The first mill in New Jersey was started by Bradford in 1728.

These earliest beginnings were followed by enterprises of a similar kind in the other English colonies, a detailed account of which is unnecessary. The growth of the industry during 120 years is illustrated by the fact that in 1810 there were said to be 185 mills in the United States. Until this time the materials used in paper-making had been solely of home production, but in 1810 rags were first imported from Europe.

In 1817 there is the first record of a paper-making machine in America. This is believed to have been a cylinder machine. The first Fourdrinier machine in use in this country was set up at Saugerties, N. Y., and started by Peter Adams on Oct. 24, 1827. This was followed by others, and some of the most important changes in paper-making mechanism have since that time found birth in America. In 1828 the system of uniting two sheets of paper in the process of formation so as to make a thicker sheet was invented and put in operation here.

Various improvements in paper-making machinery have been made from time to time. The Fourdrinier, while preserving its form and essential principles, has not been neglected, but in many respects has received the benefit of American invention. So, too, with the cylinder machine, which has developed from a single cylinder to two, three, and four cylinders. The Harper improved Fourdrinier, invented by James Harper, of New Haven, is a combination of the Fourdrinier and cylinder machines, the direction of motion requiring that the Fourdrinier shall be turned end for end. It would be impossible, however, to review all of the details of the changes in paper-machines and in paper-making machinery in general. In all of the processes, from the handling of the raw material to the output of the finished product, in the preparation and cleaning of the stock, in the work of boiling, beating, and reducing paper-making fibres to pulp fit for conversion into paper, and in carrying forward the work of manufacture, the skill of the American inventor and artisan has been called into play. Not the least noteworthy fact in this connection is the increase in the speed of the Fourdrinier machine, the rapidity of manufacture in America being regarded with surprise by the paper-makers of other countries. While this machine formerly ran at a rate of speed capable of producing 24 lineal ft. of paper per minute, afterwards increasing to 40 ft., which was regarded as an important advance in manufacture, American machines are now speeded up to the production of 250 lineal ft. of paper, the full width of the machine, and this is not regarded as an extraordinary occurrence except by those who are unfamiliar with American paper-making and its methods.

In the preparation of the pulp much improvement has been gained by the introduction of what are called refining-engines, of which those known by the names of their respective inventors are the type. These embrace the Kingsland engine, the Jordan, the Gould, the Jeffers, and the Marshall, all of which are in use, some of them in Europe, although the introduction of these machines in European paper-mills has been slow, and their employment there for the most part is of recent growth. As adjuncts of the paper-machine and for finishing purposes the calenders, consisting of sets of metal or paper rolls combined in a frame, and forming what is called a stack, have also been the subject of improvements. Chilled-iron rolls are used in these stacks, and one of the most important improvements in connection therewith has been the invention of a machine for grinding the faces of these rolls and rendering them true and perfectly cylindrical. This machine is of American origin, and the only one of its kind. Various devices for use in connection with the calenders, such as calender-feeds, etc., have also originated in the United States, and become recognized

appendages of the machine. As the paper after passing through the calenders has sometimes to be wound and made into rolls, an appendage known as a winding-machine, and by which the paper can be wound into different length, after being cut into widths as it passes from the calenders, has been invented. This winder has several reeling devices automatic in action, and maintains an even tension on each separate strip or web of paper, and in case one strip breaks the other rolls stop until a splice is made of the broken web. Aside from these mechanical improvements noted there are many others. The means for conveying power to the machinery have all been largely improved, but these and many other details must be passed by.

In considering the growth of the American paper industry the results of the introduction of mechanically prepared wood-pulp and of wood-fibre produced by chemical treatment must not be overlooked. The method of grinding wood so as to render it useful as a raw material for paper was introduced in the United States about 1869-70. This was the first great step in the cheapening process for ordinary news- and print-papers, and it has served to bring down the price of the manufactured article so that the product which was sold as late as 1879 at 9 cts. per lb. is now (1888) to be bought for 4 cts., and is at the same time of better quality. This cheapening process has been aided by improvements in pulp-making machinery made by American inventors, but is chiefly due to the growth of this branch of the paper-making industry, aided by a tariff which has encouraged the extension of the industry and increased home competition. The chemical treatment of wood, resulting in what is known as wood-fibre, possessing stronger characteristics than wood-pulp, and which goes into finer grades of paper, was inaugurated in this country in 1854. This consisted in the reduction of the wood to its pure fibre, or cellulose, by boiling and treatment with alkaline solutions. The process is generally known as the soda process, and was first put in operation at Royer's Ford, Pa., where it is still practised, and has since extended to various parts of the country. This alkali or soda process induced many mechanical inventions for its perfection and development. Of late another chemical process of disintegrating wood and separating its fibres so as to adapt them for conversion into paper has come into competition with the alkali process, and with marked influence on the latter. This is known as the bisulphite process, and consists in treating wood under pressure with a solution of sulphurous acid in combination with a base. This is essentially an American invention. It was suggested and patented by Tilghman, of Philadelphia, in 1869, but its costliness prevented its practical application and development at that time. Later, the process was taken up in Europe, and means for conducting it on a profitable basis were perfected, the American process maintaining its position as a foundation principle. This fibre goes into various grades of print- and writing-papers.

There are two other features of American paper-making which have had influence on the industry at large. The first is the manufacture of straw-boards, which was started by G. A. Shryock, of Chambersburg, Pa., in 1829, and is still continued, improvements having been made in this branch of production also. Coated-paper for fine book-work is the other. The elegance attained in the production of illustrations in magazines has been due to a finish given to the surface of the paper by means of a white coating after the paper has been made.

The latest and what promises to be one of the most important changes in paper-making methods has been recently developed. This is the process of bleaching paper-pulp by the employment of electricity, which is utilized to electrolyze the bleaching solution. This is also the invention of an American; first put into successful and practical operation in 1888. It effects a great saving of bleaching material, and insures an economy in manu-

facture which may induce a revolution in the production of what are known as bleaching-powders.

In concluding this condensed review of paper-making in America some further statistics of the trade will be found of interest. There are in the United States about 1100 paper- and pulp-mills. The mills located in other parts of America number 85. These, with those projected, and on which the work of construction has begun, will doubtless make the record for 1888 fully equal to 1200 mills representing this important industry in this hemisphere. There are in the Dominion of Canada 62 paper- and pulp-mills; in Mexico 11 paper-mills; while in all of the remainder of America, including the West India islands, there are only 12 mills.

The value of the paper manufactured in the United States in 1820 was estimated at \$3,000,000, and the business gave employment to 5000 hands. In 1873 the production was 317,387 tons, the capital invested was \$43,500,000, and the help employed numbered 22,042. During the last eight years the American paper industry has advanced from No. 21, as classified among the manufacturing industries of the country in the census tables of 1880, to No. 14 in the same classification, having nearly doubled in value. The following are the statistics of the trade for 1887:

Capital invested.....	\$80,000,000
Tons of paper made.....	1,200,000
Value of product.....	\$95,000,000
Number of hands employed.....	40,000
Wages paid.....	\$18,500,000

The total *daily* producing capacity (in lbs.) of the paper- and pulp-mills of the United States for the years undermentioned is given in Lockwood's *Directory of the Paper-Trade* (14th ed.) as follows: 1881, 5,315,400 lbs.; 1883, 6,949,800 lbs.; 1884, 7,867,830 lbs.; 1885, 8,147,060 lbs.; 1886-87, 8,354,480 lbs.

(J. A. C.)

PAPINEAU, LOUIS JOSEPH (1789-1871), a Canadian politician, was born at Montreal in October, 1789. He was educated at Quebec and admitted to the bar, but did not practice. Elected in 1809 to the provincial parliament, he became the speaker of the house in 1815. Lord Dalhousie tried to neutralize his influence as leader of the French party by making him a member of the executive council, but Papineau would not attend its meetings. When he was again chosen speaker in 1827 Lord Dalhousie adjourned the parliament. Papineau prepared the list of grievances subsequently known as the 92 Resolutions, which he supported in the house and afterwards by speeches throughout the country. He also recommended commercial non-intercourse with England. In 1836 he induced the parliament to vote only six months' supplies to the government, but the measure was vetoed, and the administration conducted without regard to parliament. As long as the French party followed Papineau, their opposition was confined within peaceful limits, but when they took up arms he publicly declared that resistance by constitutional means would alone avail. The rebels were soon defeated and Papineau, who was proclaimed an outlaw, took refuge in the United States. Thence he passed to France, but in 1847 he returned to Canada under the amnesty of 1840, and was again elected to parliament. Though he retained his popularity, he did not resume his leadership. In 1854 he retired from public life, and he died at Montebello, Sept. 23, 1871.

PARDOE, JULIA (1806-1862), an English author noted for abundance of her literary labor, was born at Beverley, Yorkshire, in 1806. At the age of 13 she had produced a volume of poems, and at 15 a novel. Her travels on the Continent and residence at Constantinople furnished material for descriptive works and romances. In 1859 she received a literary pension from the British government. She died Nov. 26, 1862. Her most important works were *Traits and*

Traditions of Portugal (1833); *City of the Sultan* (1836); *Romance of the Harem* (1839); *City of the Magyar* (1840); *Louis the Fourteenth* (1847); *Court of Francis I.* (1849); *Episodes of French History* (1859).

PARDON. In addition to what is said in the *ENCYCLOPÆDIA BRITANNICA*, Vol. XVIII., p. 271 (p. 276 Am. Rep.), it will suffice to mention that the rule or usage in the several States of the American Union in regard to the exercise of the pardoning power may be found in the second part of the article *CONSTITUTION*, treating of the "State Constitutions."

PAREPA-ROSA. See *ROSA*.

PARIS, LOUIS PHILIPPE D'ORLEANS, COMTE DE, was born in Paris, Aug. 24, 1838, being the eldest son of the Duke of Orleans and grandson of King Louis Philippe. He was educated by Adolphe Regnier, at Paris, and after the Revolution of 1848 at Eisenach. He became proficient in foreign languages and travelled extensively. In 1860 he went with his brother, the Duc de Chartres, to Syria, and published *Damas et le Liban* (1861). The brothers came to America after the outbreak of the civil war, and in September, 1861, were placed on the staff of Gen. McClellan. They remained with him until after the failure of his campaign against Richmond, when they retired to escape the complications growing out of the French operations in Mexico. On the declaration of war between France and Prussia, the Comte de Paris applied for permission to enter the French army, but was refused. In 1873, by his visit to the Comte de Chambord, at Frohsdorf, the breach between the two branches of the former royal family was healed. On the death of Chambord in 1883 the Comte de Paris was recognized as heir to his pretensions to the throne of France. Yet he lived under the Republic, at Paris, or at his Château d'Eu, and held the rank of lieutenant-colonel in the army until 1886. He was then obliged to withdraw from the country, and in November, 1887, he issued an address advising the French people to restore the monarchy. His literary ability was shown first in contributions to the *Revue des Deux Mondes* of articles on various public questions. With his brother he published *Duc d'Orleans, campagnes de l'armée d'Afrique*, 1835-39 (1870). His most important work is the *Histoire de la Guerre civile en Amérique* (6 vols., 1874-84), of which an American edition has been issued, translated by Dr. Henry Coppée. Though not free from errors, it is the best history of the war yet published.

PARK, EDWARDS AMASA, the theologian, was born at Providence, R. I., Dec. 29, 1808. He graduated in 1826, at Brown University, where his father, Calvin Park (1774-1847), was professor, and in 1831 at Andover Theological Seminary. He was pastor of the Congregational Church at Braintree, Mass., four years, and then became professor of moral and intellectual philosophy in Amherst College. In 1836 he was made professor of sacred rhetoric at Andover, and in 1847 professor of Christian theology, which post he held forty-four years, resigning in 1881. He was a foremost representative of what is called New England theology. He was active in literary work, and was one of the founders and editors of the *Bibliotheca Sacra*. He edited the works of W. B. Homer (1842), B. B. Edwards (1853), S. Hopkins (1852), and N. Emmons (1861), and wrote the accompanying memoirs, and also published biographies of other divines. To the *Discourses and Treatises on the Atonement* (1859) he furnished an introduction on *The Rise of the Euchardean Theory of the Atonement*. With Dr. Austin Phelps he edited *The Sabbath Hymn-Book* (1858), and *Hymns and Choirs* (1860). After his retirement he published *Discourses on Theological Doctrines as related to Religious Character* (1885).

PARKE, JOHN GRUBB, general, was born near Coatesville, Pa., Sept. 22, 1827. He graduated at West Point in 1849, and entered the topographical engineers. His principal work was on the north-west

boundary survey until the outbreak of the civil war. In November, 1861, he was made brigadier-general of volunteers, and took part in Gen. Burnside's expedition to North Carolina. In August, 1862, he accompanied Gen. Burnside when he joined the Army of the Potomac, served as his chief of staff at South Mountain and Antietam, and continued in the same position when Burnside took command of the whole army. After the battle of Fredericksburg, Gen. Parke had command of the Ninth corps in its march to Vicksburg, and commanded the left wing of Gen. Sherman's army at Jackson, July 12, 1863. When Gen. Burnside resumed command of the Ninth corps, Gen. Parke had a division and was engaged in the defence of Knoxville. In the campaign of 1864 against Richmond he again assumed command of the Ninth corps and took part in various operations until Gen. Lee's surrender. In 1864 he had been made major in the Engineer corps, and after the close of the war he was engaged in the office of the chief of that corps. He rose to the rank of colonel in 1884, and in June, 1887, was made superintendent of West Point Academy.

PARKER, AMASA JUNIUS, jurist, was born at Sharon, Conn., June 2, 1807. Removing to New York in early life, he became a teacher, and in 1825 graduated at Union College. In 1828 he was admitted to the bar and formed a partnership with his uncle, Amasa Parker, of Delhi, N. Y. In 1833 he was elected to the State legislature, and in 1837 to Congress, where he served one term. In 1844 he became vice-chancellor of New York, and later a judge of the State Supreme Court. In 1859 he was appointed U. S. district attorney. He was afterwards member of State constitutional conventions but held no office. He was active in procuring reform in the procedure of the courts of New York. He published 6 volumes of *Reports* (1855-69), and assisted in preparing the *Revised Statutes* (3 vols., 1859).

PARKER, FOXHALL ALEXANDER (1821-1879), commodore, was born in New York city, Aug. 5, 1821, being a son of a naval captain of the same name. He graduated from the naval school in 1843, and served against the Seminole Indians, on the Coast Survey, and in the Mediterranean squadron. On the outbreak of the civil war he was made executive officer at the Washington navy-yard and he frequently gave assistance to the operations of the army in that vicinity. With the rank of commander in 1862, he was engaged off Wilmington, Yorktown, and Charleston, having charge at the latter of a naval battery on Morris Island. Afterwards he commanded the Potomac flotilla till the close of the war, and was promoted to be captain for his services. In 1872 he was made chief-of-staff to the North Atlantic fleet and from 1873 to 1876 was chief signal officer of the navy. In 1878 he was appointed superintendent of the Naval Academy. He died at Annapolis, Md., June 10, 1879. He published treatises on howitzers and naval tactics which are used as text-books in the U. S. Naval Academy. He also translated from the Spanish *Elia, or Spain Fifty Years Ago* (1866), and published *Fleets of the World; the Galley Period* (1876); and the *Battle of Mobile Bay* (1878).

PARKER, JOEL (1795-1875), jurist, was born at Taffrey, N. H., Jan. 25, 1795. He graduated at Dartmouth College in 1811 and became a lawyer at Keene, N. H. In 1833 he was made a judge of the State Supreme Court and in 1838 became chief-justice. In 1840 he was chairman of a committee to revise the laws of New Hampshire, and in 1847 was made professor in Harvard University. He died at Cambridge, Aug. 17, 1875. Among his numerous publications were *Personal Liberty Laws* (1861); *War Powers of Congress and the President* (1863); *Revolution and Reconstruction* (1866); *The Three Powers of Government* (1867); *Conflict of Decisions* (1871).

PARKER, JOEL, D. D. (1799-1873), was born at

Bethel, Vt., Aug. 27, 1799. He graduated at Hamilton College in 1824, and was ordained to the Presbyterian ministry in 1826. He had charges in Rochester, New Orleans, Philadelphia, New York city, and Newark. He was president of Union Theological Seminary, 1840-42, holding also the professorship of sacred literature. He died at New York, May 2, 1873. He published several religious works and was for a time editor of the *Presbyterian Quarterly Review*.

PARKER, JOSEPH, English Congregationalist preacher, was born at Hexham, April 9, 1830. He was educated at University College, London, and was ordained pastor of a Congregationalist church at Banbury in 1853, and afterwards ministered to a church in Manchester. Since 1869 he has been pastor of City Temple, London. In theology he is conservative and orthodox; as a preacher he has been considered to resemble Henry Ward Beecher, and on the death of the latter Dr. Parker was invited to preach his memorial discourse. He accepted the task but afterwards returned to his work in London. Among Dr. Parker's publications are *Emanuel* (1859); *Ecce Deus* (1868), a reply to *Ecce Homo*; *The Paraclete* (1874); *Aid Clerum* (1870); *The Priesthood of Christ* (1876); *The Inner Life of Christ* (3 vols., 1881-2); *Apostolic Life* (3 vols., 1882-4). He has commenced the publication of a series of discourses under the title *The People's Bible*. His sketches of ministerial life, *Springdale Abbey* (1869), and *Tyne Chylde* (1883), are partly autobiographic.

PARKER, PETER (1804-1888), missionary, was born in Framingham, Mass., June 18, 1804. He graduated at Yale in 1831, and having studied medicine as well as theology, was ordained in 1834 and sent as missionary to China. He established a hospital at Canton which received 2000 patients in its first year. Many Chinese also received instruction in medicine and surgery from him. He visited the United States in 1840, but resumed his missionary work in 1842. As secretary to the U. S. embassy he rendered valuable service. In 1855 he again visited the United States, but soon returned to conduct negotiations with the Chinese government. In 1857 he returned to the United States and fixed his home at Washington. He was an active member of the Evangelical Alliance, and in its behalf visited the Emperor of Russia in 1871. He died at Washington, D. C., Jan. 10, 1888. He published *Journal of an Expedition from Singapore to Japan* (1838).

PARKER, WILLARD (1800-1884), surgeon, was born at Lyndeborough, N. H., Sept. 2, 1800. He graduated at Harvard College in 1826, and studied medicine and surgery under Dr. J. C. Warren. He was soon made professor of anatomy in the Vermont Medical College and in Berkshire College, and in 1836 was called to Cincinnati. After a visit to Europe he was in 1839 made professor of surgery in the New York College of Physicians and Surgeons. During the thirty years in which he held this position he made several improvements in practical surgery, including the operation of cystotomy. In 1846 he was concerned in the organization of the Bellevue Hospital, and was appointed one of its visiting surgeons. In 1864 he exerted himself to procure the formation of the New York City Board of Health and afterwards served as one of its members. In 1865 he was made president of the State Inebriate Asylum at Binghamton, and in 1869 was made professor of clinical surgery in the institution with which he had long been associated. He was also consulting surgeon to several New York hospitals, and a hospital for contagious diseases was named in his honor. He retired from practice in 1882, and died April 25, 1884. His only publications were contributions to medical journals.

PARKERSBURG, a city of West Virginia, county-seat of Wood co., is on the Ohio River at the mouth of the Little Kanawha, about 95 miles below Wheeling and 196 miles from Cincinnati. Its railroads are

the Baltimore and Ohio, the Ohio River, and the Cincinnati, Wheeling, and Baltimore; there is also a branch road to Marietta. The Baltimore and Ohio Railroad bridge over the Ohio is one of the longest in the United States. Parkersburg has a U. S. government building, 3 hotels, 4 national banks, 1 daily and 4 weekly newspapers, 12 churches, 6 public school buildings, and a female seminary. It has 3 foundries, 2 machine-shops, railroad repair-shops, 5 large oil-refineries, and several factories, producing furniture, barrels, vases, acids. There are 4 flour- and 3 lumber-mills. Parkersburg has gas- and water-works, a good fire department, and a park. Its public debt is \$125,000 and its yearly expenses \$45,000. It is the centre of the petroleum trade of West Virginia and South-western Ohio. It was settled in 1773 by Virginians, was incorporated in 1820. The population in 1880 was 6582.

PARKMAN, FRANCIS, historian, was born in Boston, Sept. 16, 1823. His father, Francis Parkman, D. D. (1788-1852), was pastor of the New North Church (Unitarian) from 1813 to 1849, and was noted for his charitable labors. The son graduated at Harvard in 1844 and then made a tour across the Western prairies, which he described in sketches first published in the *Knickerbocker Magazine*. He afterwards visited Europe. Though afflicted with partial blindness, he followed the example of Prescott and devoted himself to historical investigation. The first result appeared in his *History of the Conspiracy of Pontiac* (1851), to which his familiarity with actual Indian life gave special value. He then essayed a novel in 1856, but his subsequent works, which have brought him fame, have all related to the history of the French in North America. They comprise *The Pioneers of France in the New World* (1865); *The Jesuits in North America in the Seventeenth Century* (1867); *The Discovery of the Great West* (1869); *The Old Regime in Canada* (1876); *Count Frontenac and Neo France under Louis XIV.* (1880); *Wolfe and Montcalm* (1885). These successive volumes by their graphic style, their thorough research, and careful judgment, have become standard works on that part of American history to which they relate.

PARKS. The idea of providing pleasure-grounds for the recreation of the people of large cities is one of recent origin, though it is now being carried out with all the Nineteenth century energy. In former times the people were looked upon as of too little importance for any public provision to be made for their enjoyment, and though large tracts of forest and other lands were set aside, they were held solely for the pleasure of the nobility and royalty. Many such tracts of crown lands have recently been utilized as parks for the people, a striking evidence of the growing importance of the populace. This is particularly the case in France, where numerous preserved portions of the ancient forests are now thrown open as public pleasure-grounds.

In the old English manors the grounds were divided into two portions. One of these immediately surrounded the house, and was treated as a garden or an elaborately ornamented pleasure-ground. The more distant portion, known as the park, was less artificially treated, being left principally to the broad handling of nature. Most of these old parks were originally kept as deer enclosures, and had the proper alternation of open forest, grassy dales, and flowing streams for this purpose. In many of the manorial parks the people were given privileges, and in some of them they acquired legal rights of crossing, but no park existed in the modern popular sense.

The recent European parks are as a rule old private parks, or crown lands, now made free to the people and adapted to public use. For this purpose they have been treated so as to bring out all their possibilities of landscape beauty, being in some parts dealt with elaborately as gardens, but usually on a broader

and freer scale than that suitable to landscape gardening. It is the design in the park, indeed, to give a suggestion of the open country, not of the contracted house grounds, and for this it needs to be of considerable extent, and to embrace woodland, open meads, glens, elevations, small lakes, flowing streams, and all that constitutes and enhances the charm of attractive landscapes. All this, of course, is necessarily done on a small scale, except in the few parks of enormous dimensions, and the effort to improve the natural advantages to the utmost leads usually to an artificial arrangement which is far removed from the work of nature, but which is, perhaps, more pleasing to city eyes.

Of European cities, Paris and London are the best provided with parks. In France, as we have already said, the ancient state forests have been utilized for this purpose. There are more than 20 such domains open to public use, within easy reach by rail of Paris, varying in size from St. Cloud, of 1000 acres, to the great forest of Fontainebleau, with its 81,740 acres and its thousands of miles of roads and paths. Some of these possess much natural beauty, such as fine old trees, stretches of beautiful lawn, winding streams, picturesque scenery, etc. They have already been adapted to the enjoyment of many generations of kings and nobles, and need little further change to make them suitable for the recreation of the people. Of those within ten miles of Paris the parks of Boulogne, Vincennes, St. Cloud, Marly, and St. Germain are among the most notable. Versailles is yet more famous, being admired for its palace and gardens more than for its woodland scenery. The real parks of Paris, however, are Boulogne (2158 acres), and Vincennes (2225 acres). These are near the city, and form the chief daily recreation-grounds of the people. The Bois de Boulogne is not well adapted by nature for park purposes, being level and with poor soil, yet it has been much improved in the portions adjoining the great avenues which traverse it. There are in addition several small parks of from 40 to 75 acres, and numerous city squares.

London is abundantly supplied with parks and small breathing-spaces, which are well distributed throughout the city, and comprise in all a very considerable area. In the West End, for instance, occur Hyde Park (390 acres), Regent's Park (470 acres), Kensington Gardens (360 acres), Green Park (70 acres), St. James Park (80 acres), and several smaller places. The other quarters of the city are equally well provided, while outside the metropolitan limits are numerous places of public resort, among them several of great extent. Epping Forest, now set aside for public use, contains 5600, Richmond Park 2253, and the more distant Windsor Park 3800 acres.

The other cities of Europe, while not equally well provided with public pleasure-grounds, have their parks, some of them quite extensive, and are adding to their advantages with commendable rapidity. One of the later ideas in this direction is the formation of broad drives or parkways, adorned with trees and grassy margins, walks, drives, and seats, and so laid out as to form trunk-lines of traffic, with the interior streets as feeders. Paris has taken the lead in this conception, and has over 80 miles of such avenues, from 100 to 300 feet wide. In all this city has 120 miles of tree-lined boulevards.

In the above respects Europe is in advance of the United States, in which the park idea is only about 30 years old, though it has been carried out since its inauguration with that activity which forms a distinguishing American characteristic. In planning the city of Philadelphia William Penn provided five breathing places for the inhabitants, which have recently been much improved, though the largest one of them, indeed, has been swallowed up as a site for the new City-Hall. Boston took a similar step as early as 1634, by laying aside the Common as a public garden, though it long continued unimproved, and was used as a cow-pasture

within the memory of living men. This small enclosure of 48 acres, with a smaller recent addition, is all that Boston yet possesses in the way of a park, though steps are now being taken to provide a series of public pleasure-grounds on a scale more in accordance with modern ideas.

The idea of the formation of Parks on a large scale in American cities seems to have originated with A. J. Downing, (*q. v.*) of New York, or at least he was the first to openly advocate it in some articles written in 1850, in which he suggested the need of a great public park in New York city. This suggestion quickly bore fruit, for in the succeeding year the mayor of that city strongly recommended the establishment of a park, and in 1853 an act was passed setting aside the locality of the present Central Park for that purpose. Another locality, known as Jones's Woods, was also named, this being a large and well-wooded tract along the East River, opposite Blackwell's Island. It had better natural advantages, but was of smaller size than the Central Park tract, and was finally abandoned in favor of the latter, which was purchased at a cost of \$5,160,369.90. The tract of land thus set aside is 2½ miles long by half a mile wide, and contains, with some later additions, 683 acres. It extends from 59th to 110th streets and from Fifth to Eighth avenues on the city plan, these streets, which were then open ground, having since been solidly built up, so that the park is now completely embraced by the city. One awkward feature of the locality is the existence of the two Croton reservoirs, of 150 acres in extent, which are so situated as to divide the park tract into two portions, with but a narrow line of connection, and have been a serious detriment to its full adaptation to public use.

Plans for its improvement were advertised for, the accepted one being that offered by F. L. Olmsted and Calvert Vaux, gentlemen well suited by their former studies for the proper execution of the task thus assigned them. The ground chosen for the park was by no means well adapted by nature for such a purpose. Only a few slight elevations broke its general flatness, and it presented an aspect of barren ugliness from which it seemed a hopeless task to seek to work out a scene of beauty. But by the free expenditure of money and the employment of all the resources of the landscape gardener, Central Park has been made exceedingly attractive, there being few prettier places of resort, for its extent, on the continent. The lower park (that portion below the reservoirs) was necessarily treated artificially, and is rather an extensive garden than a park in any broad sense. A rocky ridge of some slight elevation traversed it, and the ground has been handled with great skill, bringing out in full all its possibilities of improvement. Through its reaches of unbragous vegetation and broad stretches of greensward runs a wide avenue, the Mall, which is adorned with much fine statuary, and leads to the Terrace, a very handsome architectural feature of the park, ornamented with elaborate carvings and an attractive fountain which overlooks the lake. The latter is a winding sheet of water, managed with the utmost skill, and for its extent perhaps the most attractive bit of water scenery in any American city park. Beyond the lake extends the Ramble, a hilly slope leading to the reservoir, which has been treated with less artificiality, and made to resemble an expanse of undulating woodland.

The upper park, which is connected with the lower by a narrow strip running along the reservoirs, has been differently treated. Its natural advantages were superior, and a broader handling was adopted, without the architectural adornments which constitute a leading feature of the lower section. On the whole it may be said that a very unpromising piece of land has been managed with great skill, and all its possibilities of landscape effect fully brought out.

To the attractions proper to the park have been added others of a very useful character. One corner

of it is occupied by a Zoological Garden on a small scale, while in another has been erected the Metropolitan Museum of Art, whose collection of art objects has no equal, free to the public, in this country. Among its treasures are the invaluable Cesnola collection of Cypriote antiquities and large numbers of costly paintings and statues, most of which have been recently contributed to the Museum. Near this edifice stands the Egyptian obelisk, a fine example of the monolithic marvels of Egypt, which was brought from its original seat and erected in Central Park a few years ago. To these attractions may be added the Museum of the Natural History Society, erected on the edge of the park, and well filled with geological and zoological specimens.

In addition to Central Park the city of New York possesses about 30 small breathing spaces, and the recently laid out Riverside Park, which extends along the North River from 72d to 129th street, and is notable as the site of Gen. Grant's tomb. Since the great extension of the park idea in other cities, many propositions have been made with the view of providing New York with parks on a larger scale. The topography of the city did not accord well with this desire, most of the suggested places being at distances out of easy reach by the citizens. But the extension of the elevated railroads has gone far to overcome this difficulty, and a proposition has been adopted to lay out a series of large parks on the mainland north of Harlem River. The Legislature has authorized the purchase of the necessary land, and the Commissioners appointed to consider the subject reported in 1888 as follows: It is proposed to purchase certain old estates, comprising in all 3800 acres of land, at an estimated cost of \$9,591,961, being an average of \$2500 per acre. This territory divides up naturally into five parks, of which St. Mary's, the smallest and nearest the city, contains but 25 acres. Van Cortland, the most central of the new parks, will be of nearly 1100 acres area, and is to have a rifle-range and a military parade-ground. It contains that territory which formed the "neutral ground" between the British and American forces in the Revolution, and is the scene of Cooper's novel of *The Spy*. Pelham Park, the largest of the group, is 1700 acres in extent, situated on Long Island Sound outside the city limits, and will have a series of drives for three miles along the water-side. Croton Park contains 135 acres of high land, which affords many fine views. Bronx Park derives its name from Bronx River, which runs through it. It is the most picturesque of the series, having many old trees and moss-clad rocks, while the banks of the river are abrupt and precipitous, and capable of effective handling. It is designed to establish zoological and botanical gardens on a large scale in these parks, and connect them by parkways from 300 to 600 ft. wide, and kept in the best of condition as pleasure-driving roads. This series of parks, if completed on the broad and generous plan designed, and made practically one by the broad connecting boulevards mentioned, will place New York at the head again in respect to park area, a position which it has lost by the enterprise of other cities.

In connection with the New York parks may be named Prospect Park, of Brooklyn. This tract of land, of 550 acres in extent, was far better adapted by nature than Central Park for picturesque treatment, and has been handled in such a manner as to make it a very attractive place of public resort. Its fine views are not the least of its attractions. Recently a number of boulevards, 200 ft. wide, have been laid out, leading to the park from various directions.

Philadelphia is highly favored in possessing in Fairmount Park the largest public pleasure-ground existing in any city on this continent, and in its natural adaptation to the purpose without an equal in any of the parks of the world. The original design of Fairmount Park was utilitarian, the land being purchased with the

design of preserving the waters of the Schuylkill, the drinking water of Philadelphians, from pollution. By purchase and gift, extending from 1844 to 1867, a very large tract of land was gradually acquired, containing in all 2740 acres, and constituting the largest civic park in the world with the exception of the Epping and Windsor forests near London and the Prater at Vienna. This tract of land is exceptionally well adapted by nature for park purposes. Instead of the miniature lakes of other parks it embraces a section $5\frac{1}{2}$ miles in length of a broad and winding river, on which steamboats convey passengers to its most remote localities, while innumerable pleasure-boats dot its surface. The park embraces the elevated banks of the Schuylkill, and the rolling country for a considerable distance back, through which cut a number of deep and picturesque glens, traversed by rippling streams of water. In addition there are many noble old trees and several extended groves, the original site having been well wooded. Between these extend broad stretches of turf, while elevations of considerable height yield magnificent views of city and country scenery, perhaps unequalled for picturesque beauty in any other park in the world. Taken as a whole the natural attractions of this section of the park are so decided that art has been able to do little more than to open them up by walks and drives to easy access, and nature has been left in great part to her old possession of the ground.

A unique feature of Fairmount Park is that known as the Wissahickon Glen. Here through six miles of length a picturesque stream flows between lofty, precipitous, and rugged banks, which are thickly clad with forest trees, and present at every turn in the winding ravine views of wild and romantic beauty. It has many of the features of a mountain glen, in strong contrast to the more quiet charms of the lower park, and is a scenic element without rival elsewhere in the parks of the world.

Fairmount Park was the site of the great Centennial Exposition of art and industry, to which 465 acres were devoted, and which has left as permanent adornments the massive Memorial Building, with its treasure of objects of industrial art, and the ornate Horticultural Hall, which is surrounded by an extensive landscape garden, and is filled with the choicest representatives of tropical vegetation. Another feature of interest is the Zoological Garden, the largest and best provided in the country, and the most attractive in the artistic adornment of its grounds.

Baltimore has been fortunate in securing in its Druid Hill Park a most attractive locality, unsurpassed for its natural scenery, and diversified with dells, glens, streams, lawns, and lakes, the native beauties of all of which have been fully brought out by the skillful handling of landscape artists. Druid Hill, acquired in 1860, was originally a beautiful old wood, of 450 acres, which has been added to till the park now embraces 693 acres. As modified and improved there is no more attractive pleasure-ground, of its size, in America. Recently, by the gift of a merchant, Baltimore has acquired a new park, known as Patterson Park, originally of 56 acres, but now increased to 112.

Washington, the national capital, is well provided with park facilities. The wheel-like or rather spider-web character of the streets of that city has necessarily left many small openings to which have been added several tree-planted spaces of larger dimensions. But the chief park ground of Washington is that which surrounds the Capitol and extends through the heart of the city to the President's house, a refreshing expanse of green which is but a step removed from the principal avenue. This expanse is flat and devoid of natural beauty, and owes its main charm to the labors of the landscape gardener, but it has been rendered very attractive and is certainly very convenient of access to the tired Washingtonian. At one extremity it is adorned with the towering Washington Monument, while centrally situated are the Smithsonian

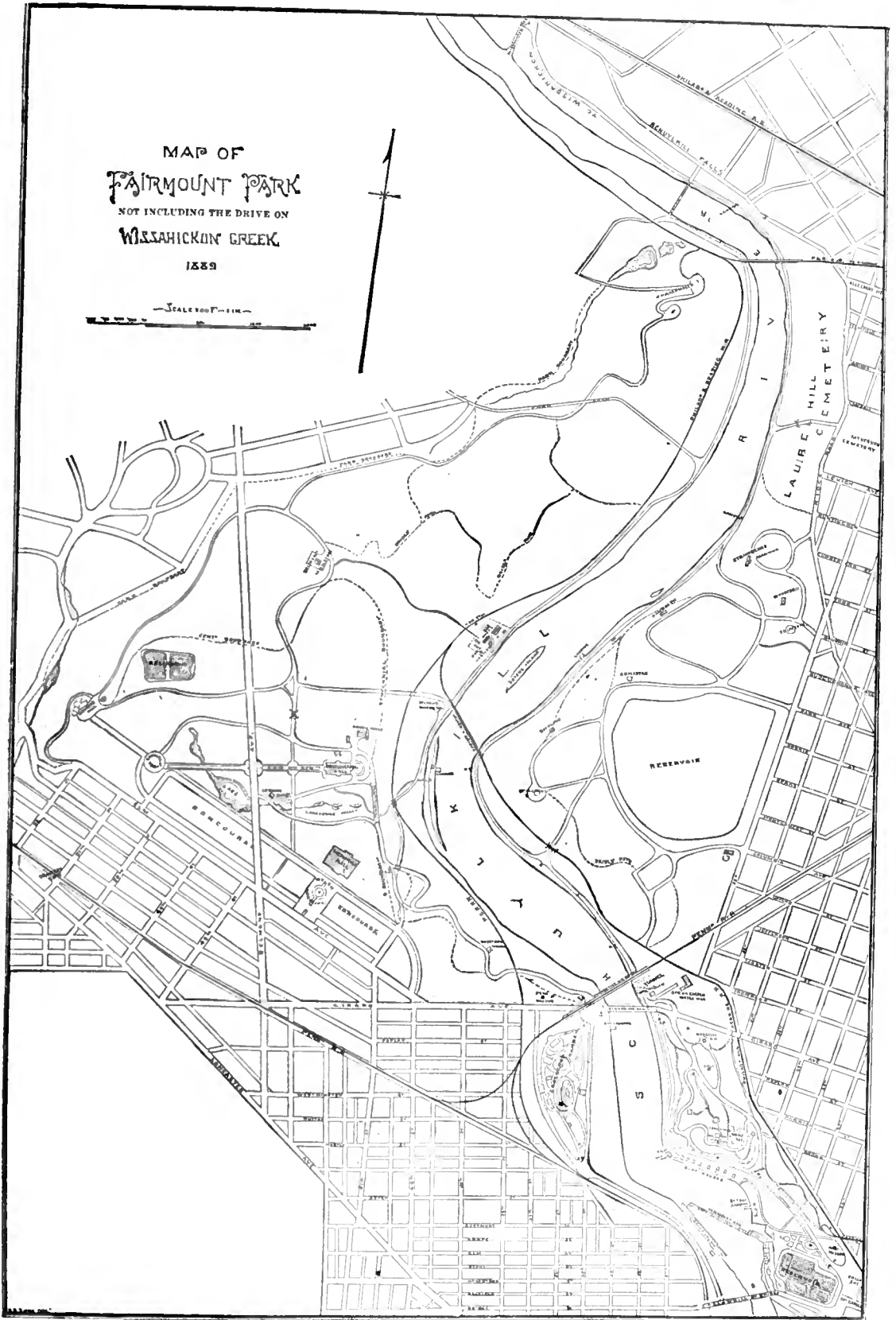

Institution and the extensive National Museum, with their immense collections of objects of nature, art, and industry.

Passing to the western cities we find Cincinnati not very extensively provided with public pleasure-grounds. Eden Park, on a hill in the eastern part of the city, contains 216 acres, and is an attractive place of resort. Burnet Woods, recently purchased for park purposes, contains 170 acres, mostly forest land. In addition there are several small city parks, containing 25 acres in all, the total park area being but little over 400 acres.

St. Louis is far better provided. It possesses nearly 2100 acres of park lands, embraced in 19 separate parks and squares. The most extensive of these is Forest Park, of 1372 acres. There may be named in addition Tower Grove Park, 266 acres; O'Fallon Park, 158 acres; and Carondelet Park, 180 acres. To these must be added the handsome and attractive Shaw Botanical Gardens, of about 276 acres in extent, and embracing the most extensive botanical collection in the United States. These valuable gardens have been donated to the city.

On the Pacific coast San Francisco possesses, in addition to several small squares, the Golden Gate Park of 1043 acres which extends to and along the ocean beach. Much of this is a bleak and sandy stretch of land, presenting none of the ordinary advantages of park localities. About one-half of it has been handsomely laid out in walks, drives, lawns, etc., its greatest attraction being a magnificent conservatory building, modelled after the Royal Conservatory at Kew, England, and well filled with exotic plants. The remainder of the tract, that bordering on the ocean, remains unimproved, and is of an inviting character for park treatment. It will need to be handled with much skill to bring out its possibilities of landscape beauty.

Chicago needs special mention from having inaugurated a park idea of its own, or one borrowed in part from Europe, which has been carried out with the energy for which the Chicagoans are celebrated. The lands surrounding this city are very poorly adapted for park purposes. With flat ground, poor soil, and a deficiency of trees and of the ordinary features of natural beauty except in the vicinity of Lake Michigan, the promise was far from good, yet the result, as shown in Chicago's chain of parks, is very beautiful and attractive. A series of parks have been thrown in a semicircle round the city, touching the lake at each extremity, and so connected by wide, tree-lined boulevards as to form virtually a single park, a system which, as we have already said, is designed to be adopted in the new parks of New York city.

In the southern district, outside the city limits, are the two South Parks, respectively of 372 and 593 acres, the larger having 1½ mile of lake front. It is designed to form in the latter a series of internal park lakes connected with Lake Michigan. North of these is the East or Jackson Park, of 600 acres, and 2 miles of lake front. It is designed in the future to connect this with the South Parks by a grand boulevard, 600 ft. wide. In the western division of the city lie three parks, the first being Douglas Park, 171 acres in area, and connected with the South Park system by a boulevard 9 miles long. Next comes Garfield Park (185 acres), and Humboldt Park (194 acres). Three and a half miles from the latter lies Lincoln Park, touching the lake north of the city, and completing the semicircle. This is the oldest and most elaborated of the parks. It contains 310 acres, has 2 miles of frontage on Lake Michigan, and contains a zoölogical garden, with beautiful flower-beds and groves of native trees. In addition to these there are many small parks within the heart of the city. The parks, with the exception of Jackson Park, are connected by broad boulevards, from 200 to 250 ft. in width, which unite the whole system into one. These

are reserved for carriage driving, their total length being 40 miles.

Others of our cities have park systems resembling that of Chicago. Buffalo, for example, has an inland park of 300 acres, from which rural promenades lead in one direction to an esplanade over Lake Erie, in the other to a parade-ground and public garden. The total park area is 530 acres.

The new park system of Boston is designed on the Chicago plan. It will begin with the Charles River embankment, an esplanade of 200 ft. wide and extending 2¼ miles along the river side. Next will come the Back Bay Park, of about 106 acres; the Muddy River improvement, of 110 acres; Jamaica Park, comprising a pond of 70 acres and a surrounding driveway of 52 acres; the Arnold Arboretum, of 167 acres; and the West Roxbury Park, of 485 acres. This will make a system of parks, connected by broad parkways 8 miles in length, and with an aggregate area of 1059 acres. The land has been purchased, but years must elapse ere the scheme can be completed. Besides the above several other parks are designed, which will make the Boston park system, when finished, a very complete one.

Of Northern cities, not above named, it may be stated that Detroit possesses a park of unusual character, as occupying an island in the middle of Detroit River. This park, Belle Isle by name, is of 700 acres area, with a bridge leading to the main land, with which it is designed to connect a boulevard 9 miles long and 150 ft. wide, curving in a crescent around the city. Cleveland possesses 93 acres of park lands, with plans for additional ones. Milwaukee has a park on the lake front with a fine view over the lake from an elevation of 80 to 100 ft. New Haven has a park of 350 acres on the summit of East Rock, on the highest point of which rock is erected a soldiers' monument of 125 ft. height. In the city of Lynn, Mass., a movement is on foot to secure the forest lands of North Lynn, 3300 acres in extent, for a public park; a project of very ambitious dimensions for a city of 45,000 inhabitants.

The cities of the South have been less active than those of the North in providing large public pleasure-grounds, though many of them are well provided with small squares. New Orleans is dotted over with such squares and has, in addition, the tastefully decorated New City Park of about 150 acres in area, which lies on the river near the north-eastern boundary of the city. The World's Fair and International Cotton Exhibition of 1884-5 was held here, the buildings covering a considerable portion of the area. It was at that time unimproved, though possessed of natural ornaments in the form of live-oak trees with depending drapery of Spanish moss, but for the purpose of the exhibition it was laid out in grass plats and planted with temperate and semi-tropical plants and shrubs, while fountains, bridges, electric lights, and other features of attractiveness were added. The city squares, about 9 in number, are partly improved, though some of them remain in a state of nature. Of these Jackson Square, on the river front, is the favorite resort. It is handsomely laid out with trees and shrubbery and in its centre stands Mills' equestrian statue of General Jackson.

The city of Charleston is very deficient in public grounds and the misfortunes of fire and earthquake to which it has been subjected are likely to check any enterprise in this direction for years to come. Its principal advantages of this kind are Washington Park, a city square which contains a statue of William Pitt, and Battery Park, a popular promenade which lies near the water's edge and commands an extensive view of the bay.

Savannah, on the contrary, is unusually well provided, having no fewer than 24 small parks or squares mostly of 1½ to 3 acres in extent, at the junction of their principal streets. The largest of these is Forsyth

Park of 30 acres, which contains a fountain modelled after that of the Place de la Concorde, Paris. In Monterey Square, on the spot where Pulaski fell in the revolutionary war, has been erected an elaborate monument, comprising a marble shaft 55 ft. high, on which stands an artistically designed and beautiful statue of Liberty. Monument Square possesses a Doric obelisk, erected to the memory of General Greene and Count Pulaski, the corner-stone of which was laid by Lafayette during his visit to this country in 1825.

Atlanta possesses Oglethorpe Park of 40 or 50 acres in extent, which formed the site of the International Cotton Exposition held in that city in 1881, one of the most important and attractive of American industrial exhibitions.

Salt Lake City, Utah, is well provided with park accommodation, it being divided into 21 wards, nearly every one of which has a public square. The park idea, indeed, has extended almost universally throughout the United States, and many even of our smallest cities are adopting plans for securing public pleasure-grounds while yet suitable localities can be had at reasonable prices.

In addition to its civic parks the United States now possesses several national parks, comprising extensive tracts of land, which, on account of their unique features of natural scenery, have been withdrawn from the public lands and set aside for the use of the people forever. Two of these are in California, one being the celebrated Yosemite Valley, which, for combined beauty and sublimity of scenery, has no equal upon this continent. (See YOSEMITE.) The other is the Mariposa grove of "Big Trees" (*Sequoia gigantea*), those giants of the vegetable world which have so excited the astonishment and admiration of travellers, and are among the most striking natural wonders of the Western Continent. This park is limited to an area of 4 sections of land or 4 square miles, its primary design being to preserve these marvels of nature from the destruction to which they were exposed by the heedless greed of the speculative tree-choppers who have already wrought such havoc in the American forests. In this remarkable grove there are said to be 365 trees of 10 ft. diameter and over, besides very many smaller ones. The highest tree is 272 ft., being 53 ft. lower than the highest of the Calaveras grove, but its trees exceed those of the latter in average bulk, the largest having still a circumference of 94 ft., after being much reduced by burning. The remains of a giant tree on the ground indicate a height of 400 and a diameter of 40 feet. A third national park, the most extensive of all known parks and the most extraordinary for its natural scenery, is the YELLOWSTONE NATIONAL PARK (*q. v.*). We need but say here that it embraces an area of 3579 square miles, within which it is said that there are more hot springs and geysers than in all the remainder of the earth.

To the above-named national parks has recently been added another, established with the same commendable purpose of preserving America's great features of natural scenery for the use of the public forever. This is the Niagara Park, set aside by order of the State of New York in conjunction with a similar commendable action of the Canadian authorities. The park on the American side is to be about a mile long and of varying width, from 100 ft. at the head of the upper rapids to 800 ft. at the falls. Everything obstructing the view of the rapids and falls is to be removed and the ground restored, as nearly as possible, to its natural condition, no artificial obstructions of any kind being permitted. The Canadian approach to the falls is to be treated in the same manner, and this noble phenomenon of nature will hereafter be free from the exactions and obstructions which have heretofore interfered with the enjoyment of its grandeur. (See NIAGARA.)

The Canadian government has recently followed the

example of that of the United States in setting aside a large tract of land possessing interesting natural features as a national park. This tract, on the line of the Canadian Pacific Railroad, is laid out on a generous scale, embracing 260 square miles of territory. The railroad reaches it at Banff, a station 20 miles within the Rocky Mountains and 40 miles from their summit. This district possesses hot sulphur springs of excellent curative properties, and an abundance of fine natural scenery, including mountains, rivers, etc. The springs have been improved and beautified, picturesque bath-houses and cottages built, and many miles of carriage road laid out and graded through the park. The rivers are spanned by bridges and bridle-paths have been made in all directions. The railroad company has built a commodious hotel at Banff for the convenience of tourists, but has no control over any other portion of the tract, which is held for the free use of the public.

It is of interest to note that not only governments, but private societies, are engaging in the desirable work of thus preserving striking monuments of art and nature. The Peabody Museum of Ethnology and Archæology has recently, at the suggestion of Prof. F. W. Putnam, purchased and set aside as a public park the Great Serpent Mound of Adams co., O., with about 70 acres surrounding. This remarkable work, in the form of a huge serpent 700 ft. in length, winding in an undulating manner along the summit of a hill, and apparently swallowing an egg-shaped body represented by a mound 160 ft. long, is unique among archæological remains, and the steps taken for its permanent preservation are highly commendable.

It is much to be desired that this system of preserving striking features of natural scenery by the establishment of national parks may be extended to all localities throughout the world which are possessed of remarkable scenic characteristics, or striking works of aboriginal art, and which are exposed to injury or to withdrawal from the use and enjoyment of the public. There are many such localities, unique in their features of interest, in various regions of the earth, which should be thus preserved, and it is to be hoped that the example set by the United States may be followed by the national guardians of all such localities. (C. M.)

PARLIAMENTARY PRACTICE. Blackstone observes that the word "parliament" was first applied to general assemblies of the states under Louis VII. in France about the middle of the twelfth century, but in that country it came eventually to be the designation of a body which performed certain administrative functions, but whose principal duties were those of a court of justice. From France the name was carried into England and applied to the great council of the English nation; but, as the word comes from the French *parler*, to talk, the title parliament has been extended to other deliberative assemblies which meet for the purpose of debating and deciding questions which may be submitted. In a general sense, therefore, a parliamentary body is one that meets for the purpose of discussing, deliberating, and deciding in an orderly and formal manner. Such a gathering may be termed a parliament, a congress, a convention, or it may be known by some other name.

Parliamentary law is the rule of action which should direct and control the proceedings of a parliamentary body. It is evident that some law or common understanding which shall bind and control the members in the transaction of business is needed in a deliberative body just as much as in the body politic. A state without a law, or without laws to which obedience is rendered, is in a condition of anarchy, and a deliberative assembly without binding laws would, likewise, be in an anarchical condition. Parliamentary law tends to prevent confusion and insures dignified despatch in the transaction of business. It is the result of long

experience and many tests in bodies most competent to comprehend what is necessary. It is based upon the principles of equity and is intended to guarantee justice to the entire body and to the individual, and, so, is specially valuable for its power to protect the minority and even of the humblest member.

The general principles of parliamentary law are to be gathered from the fixed rules and established usages of deliberative bodies of great dignity and authority. Hence the highest deliberative body in the land is usually recognized as the standard authority in parliamentary matters. Thus, in Great Britain the British parliament is so considered, and other bodies, whether secular or sacred, model their conduct upon the example set by the Houses of Parliament. Just as many of the laws in force in the United States run back to Britain, so the parliamentary law of this country is based upon the practice of the British Parliament; but, as the laws of the United States, though originally based upon those of England, have, through the course of years since the separation from the mother country, and because of our peculiar needs, become greatly modified, so, through different demands springing from changed circumstances, there have grown up practices in American parliamentary bodies which differ from the English, and, as these developments are peculiarly American, they give us what, in contradistinction from the British, may be termed American parliamentary law.

Variations in practice may be found in different bodies, even in the United States; but, notwithstanding these variations, there are certain general principles which are recognized everywhere throughout the land, and these general principles may be termed American common parliamentary law. These principles have been collated by certain recognized authorities on parliamentary law, and they are sometimes styled Parliamentary Practice, Rules of Order, or the Law and Practice of Legislative Assemblies. Thomas Jefferson, in his *Manual of Parliamentary Practice*, prepared when he presided over the Senate, did much to formulate the principles and spread the knowledge of American parliamentary law, and the rules of practice in his manual are to-day recognized by Congress "in all cases to which they are applicable, and in which they are not inconsistent with" other rules subsequently made. Many other writers have presented the later modifications in parliamentary practice.

Deliberative bodies, including the Congress of the United States, usually adopt rules for their own government, at least special rules which appear to be demanded by the peculiarities of their work or the peculiar purposes of their organization; but, where no such special rules exist, or when points arise to which their rules do not apply, the body is bound to obey general usage or, in other words, common parliamentary law. For the same reason, until an assembly adopts rules and orders, it is governed, and its proceedings are regulated, by the common parliamentary law. Even the national House of Representatives would come under this rule. Hence, where the general principles of parliamentary practice are well understood it may only be necessary to formulate a few specific rules to provide for peculiar circumstances. Sometimes the rules adopted vary from common parliamentary law which is broader even than congressional practice in some instances.

The organization of a parliamentary body implies a presiding officer who may be called a president, speaker, moderator, chairman, or who may be known by some other name, whose duty it is to see that the business is conducted in an orderly manner. It also implies a body of members who present, discuss, and decide the various propositions brought before the assembly.

Business is introduced under the form of motions or resolutions. In a parliamentary sense a motion is a formally worded proposition presented in a deliberative

body for its consideration and decision. The member offering it says: "I move," etc. The resolution is a more formally worded proposition and begins with the word "Resolved." The questions are decided by vote, and usually a majority vote determines the judgment of the house. In a few exceptional instances a different vote is required. The form of voting varies. Sometimes it is by voice, sometimes by show of hands, sometimes by counting the members as they stand, and sometimes by ballot.

In putting a question, the usual form is for the presiding officer to say: "The question is on the adoption of the motion (or resolution) which you have just heard. As many as are in favor of its adoption will say Aye." The ayes having voted, he will then say: "As many as are of a contrary opinion will say No," or "All opposed will say No." The chair, judging from a comparative estimate of the number of voices heard, will then announce the result, stating that the motion has been carried or lost, as the case may be. Where a hand-vote is customary, the hands are raised for or against in the same manner. The voice- and hand-votes are not precise but only approximate. The presiding officer is governed by the voices he hears or by the hands he sees; but, frequently, it is impossible for him to say positively how many voted on one side or the other, or even to say which side predominates. Where the chair is in doubt, he may ask the members to rise and stand until counted, and by this exact method determine the precise number voting on each side. This method, which is termed a *division of the house*, must be resorted to on the demand of any member, if the member expresses a doubt as to the accuracy of the judgment of the chair on a voice- or hand-vote. The proper procedure is for the member doubting to rise and say, "Mr. President, I call for a division of the house." Whereupon the chair will say, "A division is called for. Those in favor of the motion (or resolution) will rise and stand until counted." In a similar way he will take the opposite. By such a division the exact vote on each side will be ascertained, and the chair will announce his decision accordingly, even if it reverses his former opinion.

In taking a division the members, as they stand in their places, are sometimes counted by the presiding officer and sometimes by the secretary or clerk. More than one person should count in order to ensure accuracy.

Another form of dividing is that of passing in file between *tellers*. In this method the speaker appoints two tellers, one from each side of the question. These tellers take positions in the space in front of the presiding officer, and the members pass in single file between them, those on the affirmative side passing first and then those on the negative.

Another method of voting is that of taking the *yeas and nays*, so that each member shall answer when his name is called, and have his vote recorded. In Congress the vote must be so taken when the call is sustained by one-fifth of those present.

Sometimes voting is by ballot. This method is resorted to when the rule of the body requires it, and is quite common in the election of officers, in the admission of members into societies, and also when secrecy is desired. Sometimes white balls and black balls are used; at other times slips of paper are employed.

If the speaker is a member of the body he has a right to vote, but he does not ordinarily do so unless his vote would be decisive. The rule of the U. S. House of Representatives is that the Speaker "shall not be required to vote in ordinary legislative proceedings, except where his vote would be decisive, or where the House is engaged in voting by ballot."

Motions generally are debatable; a few are not. Most motions require only a majority vote, but a few require a larger vote.

After a motion has been made other motions bearing

upon the original motion may be presented. Then the original motion is called the main question, and the motions bearing upon it are called subsidiary or secondary motions.

The most common of all these subsidiary motions is the motion to amend, the object of which is to amend or improve the primary motion. The amendment must be germane to the subject-matter of the main question. A motion may be made to amend the amendment. This is sometimes called an amendment in the second degree. The vote is first on the amendment to the amendment, then on the amendment as amended or not, and finally on the original motion as amended or not amended.

A substitute is of the nature of an amendment, but its scope is broader. No amendment is permitted at one time beyond an amendment to an amendment, but late practice makes it possible, while an amendment to an amendment is pending, to offer a substitute and an amendment to the substitute. Thus the *Digest of the House of Representatives of the United States* says: "It has been for many years the practice of the House that there might be pending, at the same time with such amendment to the amendment, an amendment in the nature of a substitute for part or the whole of the original text, and an amendment to that amendment. . . . So that, notwithstanding the pendency of a motion to amend an amendment to the original matter, a motion to amend, in the nature of a substitute, and a motion to amend that amendment, were received, but could not be voted on until the original matter was perfected."

The motion to *postpone to a certain day* or to a certain time is intended to postpone the question to the time specified. If carried, the question cannot be taken up before that time except by a two-thirds vote, but when the time is reached the subject is entitled to be taken up in preference to everything except privileged questions.

The motion to *postpone indefinitely* is intended to suppress a question, and, if carried, it removes the question from consideration for that session.

The motion to *refer* or *commit* is intended to take the question from the main body and transfer it to the consideration of a committee. The motion to *recommit* is the same as to refer, only that it relates to matter already reported by the committee. All the above-mentioned motions are debatable. In some legislative bodies the motion to refer is not debatable, but, according to common parliamentary law, it opens the merits of the main question to debate.

The motion to *lay on the table* possesses the character of postponement, but it keeps the subject directly within the reach of the body. It is intended to remove the question from consideration until the house votes to take it up. This can be done at any time by a majority vote. If such a vote cannot be obtained the measure is effectually suppressed, but the motion in itself is not a finality but merely a temporary disposition of the question. Because of this the motion is not debatable. As a general thing the motion tables everything that adheres to the motion upon which it bears. Thus if an amendment is laid on the table it carries with it the main question. There are, however, a few exceptions, thus: as a question of privilege does not adhere to the subject it interrupts, it does not carry with it to the table the question pending when it was raised; an appeal laid on the table does not carry with it the original question; a motion to reconsider, when laid on the table, leaves the original question where it was before the motion to reconsider was made; and, an amendment to the minutes, being laid on the table, does not carry the minutes with it.

The *previous question* in American practice is very different from what it is in the English. In American usage it is simply a method for cutting off debate, and is equivalent to the question, Shall the discussion now cease? It is itself undebatable, and if it is carried it

brings to an end the debate on the main question. A member says, "I move the previous question," but, when the chairman puts the question, he says, "Shall the main question be now put?" The previous question may be limited to a pending amendment or it may cover both amendment and main question. In common parliamentary practice the previous question requires a two-thirds vote, but in some legislative bodies a majority vote is sufficient. It ought, however, to require a two-thirds vote, because it cuts off the natural right of a member to discuss a question, and that should not, at least in ordinary bodies, be in the power of a bare majority.

Another class of motions is called *incidental questions*. These are so called because they are occasioned in a casual way during the consideration of principal, subsidiary, or other questions, and, from their very nature, they must be decided before the questions which gave rise to them. They cannot be amended, and, excepting the case of an appeal, they cannot be debated, and even an appeal is not always debatable.

The incidental questions are: (1) Questions of order (including an appeal from the decision of the chair); (2) objections to the consideration of a question; (3) reading of papers; (4) withdrawal of a motion; (5) suspension of the rules.

If a member notices anything in the procedure which he thinks is a violation of good parliamentary usage or of the rules of the body, he may arise, and, addressing the chair, say: "I rise to a point of order." The chairman then interrupts the proceedings, and says: "The member will state his point of order." After the member has stated the point, the presiding officer decides that the point is (or is not) well taken. If any member is not satisfied with the correctness of the decision he may take an appeal to the meeting itself. The question then is, "Shall the decision of the chair stand as the judgment of the assembly?" Ordinarily an appeal is debatable. It is not debatable, however, if the previous question was pending at the time the point of order was raised. When the appeal is debatable, the previous question and the motion to lie on the table may be applied to it, but, if adopted, they affect nothing but the appeal. To sustain the chair does not require more than a majority vote, but even a tie vote sustains his decision, on the principle that the decision can be reversed only by a majority.

According to present practice any motion may be withdrawn by the mover before a decision or amendment, but not after the previous question has been ordered. To suspend the rules of a body requires a two-thirds vote.

Privileged questions constitute another class of motions. They are called privileged questions on account of special privileges which they possess because of their pressing importance. They may be introduced almost at any time, and, when properly introduced, must be considered before any other subject or proposition that may be before the house.

The privileged questions are: (1) To fix the time to which the body shall adjourn; (2) to adjourn; (3) question of privilege; (4) a call for the orders of the day.

It is sometimes said that a motion to adjourn is always in order, but this is not strictly correct. There are times when it is not in order. Thus, if the motion to adjourn is lost, it cannot be repeated until there has been some intervening business, or at least some progress in debate. Neither can a motion to adjourn be made while a member has the floor; yet the member may, if he pleases, give way, in order that the motion may be presented. A motion to adjourn cannot be received while the yeas and nays are being called, or the members are voting on any question, or when the previous question has been called and sustained and is still pending. The unqualified motion to adjourn cannot be debated, and cannot have any amendment or any other subsidiary motion applied to it, and

the vote on it cannot be reconsidered. It supersedes all other motions except the motion to fix the time to which to adjourn. The latter motion does not adjourn the meeting, but is intended to fix the time to which the adjournment will stand when the meeting does adjourn. This motion takes precedence of all other questions, and may be made after the meeting has voted to adjourn if the presiding officer has not announced the result of the vote. It may be amended by altering the time.

The general rule as to the rank of questions is that of the U. S. House of Representatives, which is as follows: "When a question is under debate no motion shall be received but to fix the day to which the House shall adjourn, to adjourn, to take a recess, to lay on the table, for the previous question, . . . to postpone to a certain day, to refer or amend, or to postpone indefinitely, which several motions shall have precedence in the foregoing order."

The motion to *reconsider* is intended to bring back before the house a question that has been decided, and to place it before the house just as it stood before the vote was taken upon it, but as the rule of the U. S. House of Representatives puts it, "The fact of a question having been decided under the operation of the previous question does not prevent debate on the motion to reconsider if the original question was otherwise debatable." The motion to reconsider may be applied to votes on all questions excepting on motions to adjourn, to suspend the rules, affirmative votes on motions to lie on the table or take from the table, on matters which have passed from the possession of the house, and on the previous question when it has been partly executed. It may be made when other business is before the house. In such a case the motion is entered upon the minutes, the business before the house proceeds, and the motion to reconsider is held over to be called up at any time before the close of the session.

The general rule is that the presiding officer must recognize the member who is first up and first addresses the chair, but there are a few exceptions. Thus, the member upon whose motion the subject has been brought before the body, if he has not spoken to the question, has the prior claim. No member can be deprived of his rights by the chair as long as he is in order, and it is not within the province of the presiding officer to cut off debate. Even after a vote has been taken and the result declared, if it appears that a member did rise and address the chair, but was not recognized, then his right to speak must be admitted, and the question will stand as though no vote had been taken.

In Congress and in the State Legislatures bills are read three times. Where the Legislature is a double body, consisting, for example, of a Senate and a House of Representatives, a bill after passing one body is sent to the other. If both bodies agree to its passage, then it is sent to the president or chief-executive for his signature. If the second body makes amendments in the bill, then, when it is returned, the house where it originated considers the amendments. If there is not agreement between the two houses, each house selects a committee of conference, and this committee endeavors to agree upon amendments which will meet the approval of both bodies. If the chief-executive vetoes the bill it is returned to the house where it originated; then, if it receives a two-thirds vote of each house, the bill becomes a law without the approval of the executive.

Parliamentary law has become a vast study. *The Law and Practice of Legislative Assemblies*, by L. S. Cushing (Boston), is a large octavo of 1063 pages. Besides this standard work, the following may be consulted: *Jefferson's Manual*; *Digest of Rules and Practice of the U. S. House of Representatives*; O. M. Wilson's *Digest of Parliamentary Law*; *Warrington's Manual*; *Cushing's Manual*; *Robert's Rules of Order* (Chicago); G. T. Fish's *Parliamentary Law*; *Rufus Waples' Hand-Book on Parliamentary Practice*; T. B. Neely's *Parliamentary Practice*. (T. B. N.)

PARNELL, CHARLES STEWART, the Irish agitator, is descended from an English Protestant family originally settled in Cheshire. His paternal grandfather, Sir Henry Parnell, was a member of Parliament, and in 1841 was raised to the peerage as Lord Congleton. His maternal grandfather was Rear-Admiral Charles Stewart (1778-1869) of the U. S. Navy, familiarly known as "Old Ironsides." Parnell was born in June, 1846, at Avondale, County Wicklow, Ireland. He was educated in English schools and at Cambridge University, where he remained two years. After travelling through the United States he settled down on his estate in Ireland, and in 1874 was made sheriff of Wicklow county. In the next year he was elected to Parliament from Meath as a Home-Ruler. Isaac Butt (*q. v.*) was then the leader of this party, but Parnell and Biggar soon introduced a policy of obstruction which he did not favor. Their object was to compel the Parliament to redress the grievances of Ireland under a penalty of having all the parliamentary work greatly delayed or entirely stopped. By persistent speaking on every subject that afforded an opportunity they wearied out the patience of the English members and at last obliged them to take some action on Irish questions. The Home Rule party had sought for a reform in the Irish land laws which was summed up in the three F's—Fixity of Tenure, Fair Rent, and Free Sale. In 1879 the potato crop in Ireland failed for the third time in as many successive years. Evictions of tenants from their little holdings of land followed in great numbers. Parnell, now recognized as the leader of the Irish party in Parliament, was induced by Michael Davitt to give his assent to the formation of the National Land League, which aimed at peasant-proprietorship. In October the league was organized, Parnell was chosen president, and branches formed in all parts of Ireland. In 1880 the Liberal party under Mr. Gladstone returned to power with overwhelming majority. The case of Ireland had not been considered in the election campaign, and the Parnellites, now thirty-five in number, resolved to remain in opposition in Parliament and continue the policy of obstruction. Mr. W. E. Forster, the Secretary for Ireland, soon brought in Coercion Bills which justified Parnell's forecast of the situation. Under the pretence of the increase of outrages in Ireland they suspended the *Habeas Corpus* and required the disarming of the Irish people. Then Mr. Gladstone introduced his Land Bill, which went far towards meeting the original demands of the league. Yet Parnell and his adherents resolved to maintain the organization until it was sure that the action of the courts under the new act would be equitable and satisfactory. The government, on the other hand, guided by Mr. Forster, determined to crush all opposition, and in October, 1881, arrested Parnell and others under the Coercion Act and imprisoned them in Kilmainham Jail, Dublin. The league was outlawed, but it replied with a "No Rent" manifesto. The ensuing struggle proved too severe for the administration. Mr. Forster was dismissed and Parnell was released on parole in April and unconditionally in May, 1882. He returned to Parliament in triumph, but the victory of the Irish cause was overthrown by the assassination in Dublin of the new Chief Secretary, Lord Frederick Cavendish, and of Edmund Burke, the under secretary. A Crimes Act was speedily passed and Home Rule sank out of sight. The policy of obstruction had been neutralized by the *clôture* acts which increased the power of the Speaker of the House of Commons over the members. However, the electorate of Ireland was soon increased from 250,000 to 750,000, and a Redistribution Bill promoted a fairer representation of the people in Parliament. But the strength of the Liberal party steadily declined, and in June, 1885, it was overthrown. In the November elections the Tories had the aid of Irish votes, but when they refused guarantees of their action in Parliament, they

were defeated on Jan. 26, 1886, and Mr. Gladstone again became prime minister. Parnell's party had secured nearly every seat for Ireland. Their demand now was for complete legislative independence and an Irish Parliament. Gladstone, convinced of the justice of the demand, soon introduced a bill for the purpose. But though it had many elements of strength, the result was to disrupt his party and drive him again from power. In the new election thus precipitated on the country the Tory party obtained enough help from the Liberal dissidents to enable it to undertake the task of governing the country. In the Parliament of 1887 Parnell's motions were defeated by large majorities, but he continued steadfast in his purpose of seeking a national parliament for Ireland.

Later a sensation was produced by the publication in the *Times* of the facsimile of a letter purporting to have been written by Parnell excusing the murder of Mr. Burke, though expressing regret for that of Lord Frederick Cavendish. Parnell repudiated the letter, but the government refused to investigate the matter. The *Times* then published a pamphlet, entitled *Parnellism and Crime*, charging Parnell and his associates with being accessories in various outrages. A suit was brought against the *Times* by one O'Donnell for libel, but was decided in favor of the defendant. This suit the Parnellites declared to be collusive. Finally in October, 1888, the charges of the *Times* against Parnell and others vaguely described were investigated before a commission of three judges. The prosecution was conducted by Sir Richard Webster, the attorney-general. The proceedings so far as they have gone (November) seem to support the view commonly held that the alleged letter which formed the basis of the indictment was a forgery.

Parnell is not a typical Irishman, according to the types presented in English literature. He is not an orator; he shrinks from public display. He is handsome in feature, quiet in manner, pleasant in his intercourse with others, perhaps slightly ideal in his aims, but thoroughly practical in the means he adopts for accomplishing them. His remarkable power over his followers is due to his absolute sincerity of purpose, the excellence of his judgment on all important questions, and the tenacity with which he maintains his conclusions. In the presence of the world he has brought an impulsive, discordant people into harmonious and almost unanimous effort for the highest privilege of a nation—the right of self-government.

(J. P. L.)

PARROTT, ROBERT PARKER (1804–1877), an American inventor, was born at Lee, N. H., Oct. 5, 1804. He graduated at West Point in 1824 and was made second lieutenant of artillery. He was assistant professor at West Point for some years, and in 1836 he became superintendent of the West Point iron and cannon foundry, Cold Spring, N. Y. He invented a system of rifled cannon which bears his name. (See **ORDNANCE**.) He died at Cold Spring, Dec. 12, 1877.

PARSLEY, *Petroselinum sativum*, a hardy biennial herbaceous plant from Sardinia, has an angular stem three to four feet in height, shining, tripinnate leaves of a rich deep green, and small, white flowers in terminal umbels, with five petals and aborted sepals. The fruit is ovate, with five narrow equal ridges, and seeds with an aromatic taste. Parsley is grown from the seed, sown annually in early spring, and is often raised under glass. It requires a rich, mellow soil. It is principally cultivated for the use of its leaves as an ornamental garnish to meats, for which purpose the double, or curly-leaved, variety is grown. By repeated transplanting during the season the curling of the leaves is aided, till they become of a regular rosette form. The leaves are also used for flavoring soups and stews, for which purpose the seeds are sometimes substituted. One variety, known as the Hamburg, is raised for its root, which is large, white, and fleshy, and resembles the parsnip. It is eaten boiled, and is

also used, mixed with the leaves, to flavor soups, to which it imparts a pleasant aromatic taste and odor.

PARSNIP. See **AGRICULTURE**, Chap. V., 2.

PARSONS, SAMUEL HOLDEN (1737–1789), general in the Revolution, was born at Lynn, Conn., May 14, 1737. He was the son of Rev. Jonathan Parsons (1705–1776), a noted preacher. He graduated at Harvard College in 1756 and became a lawyer. He was frequently elected to the Legislature and, though made king's attorney in 1774, took part with the patriots. He commanded the Sixth Connecticut regiment at the siege of Boston in 1775 and fought in the battle of Long Island. Congress made him brigadier-general in August, 1776, and in October, 1780, he became major-general. He succeeded Putnam in command of the Connecticut line. In recent years he has been charged with holding secret communication with Sir Henry Clinton and furnishing him with information of the state of the American army. In 1785 he was appointed a commissioner to treat with the Miami Indians. After serving in the Connecticut Convention which ratified the Federal Constitution, he was appointed by Washington first judge of the Northwest Territory. He settled in Ohio and took part in the purchase of the Western Reserve. He was drowned in Big Beaver River, Ohio, Nov. 17, 1789. He contributed to the *Transactions of the American Academy* a paper on Western antiquities.

PARSONS, THEOPHILUS (1750–1813), jurist, was born Feb. 24, 1750, at Byfield, Mass., where his father was pastor of the Congregational church for more than forty years. He graduated at Harvard College in 1769 and was admitted to the bar at Portland, Me., in 1774, but soon returned to Byfield, and afterwards settled at Newburyport. In 1778 he formed one of the Essex Junto, and wrote the *Essex Result*, a pamphlet which caused the rejection of a State constitution prepared by the Legislature. It had effect also on the framing of constitutions in other States. The author took part in the convention which framed the State constitution of 1780, and in the convention which ratified the Federal Constitution in 1788. In 1800 he removed to Boston and in 1806 was made chief-justice of Massachusetts. His decisions served to place on a firm basis the laws of real property and marine insurance. He died at Boston, Oct. 30, 1813. His son published his *Memoir* (1859). From his writings were collected *Commentaries on the Laws of the United States* (1836).

His son, **THEOPHILUS PARSONS** (1797–1882), was also distinguished as a jurist and as an advocate of Swedenborgianism. He was born at Newburyport, May 17, 1797, graduated at Harvard in 1815, studied law and practised at Taunton, but chiefly in Boston. In 1847 he was made Dane professor of law in Harvard College. He died at Cambridge, Jan. 26, 1882. Among his legal treatises are *The Law of Conscience* (2 vols., 1853; afterwards enlarged to 3 vols., 1864); *Elements of Mercantile Law* (1856); *Laws of Business for Business Men* (1857); *Maritime Law* (1859); *Notes and Bills of Exchange* (1862); *Law of Partnership* (1867); *Marine Insurance* (1868); *Shipping and Admiralty* (1869). Some of these works have passed through several editions. Prof. Parsons' writings in defence and exposition of the teachings of Emanuel Swedenborg include *Deus Homo* (1867); *The Infinite and the Finite* (1872); and some smaller treatises.

PARTNERSHIP is a relation founded upon a contract between two or more persons to do business as individuals on joint, undivided account. Every unincorporated association for purposes of gain is a partnership. The question whether a partnership exists or not has been said to be one of mixed law and fact, but generally speaking is one to be decided by a jury. The elements of partnership are the contribution by a partner to the partnership fund and a sharing in the profits. Each is an element in a relation not complete without both.

See Vol. XVIII, p. 329 (p. 334 Am. Rep.).

A quasi-partnership, *i. e.*, a partnership as to third persons, may result from sharing profits and not losses. Partnership is a question of intention, and the intention to contribute to the partnership and to share the profits will, if apparent, create the relation, even against the express stipulation of the parties. While the sharing of profits raises a presumption of partnership, yet it may appear that the share so taken was nothing more than a compensation for labor or service, for furnishing raw materials, etc. It has been held that the officers and crews of whaling-vessels receiving part of the produce of the voyage in lieu of wages are not partners; nor masters of vessels sailing them on shares; nor clerks receiving share of profits in lieu of wages, there being no contribution.

While there have been many, and in some instances conflicting, decisions on this question of what constitutes a person a partner, the underlying principle is, that if there is an evident intention to derive the advantages of the partnership relation, the liability attendant thereupon will also be enforced. There is no particular formality requisite to the formation of a partnership. Where there is no written agreement, it may be proved by evidence of the conduct of the parties, the mode in which they have dealt with each other, and in which each has, with the knowledge of the other, dealt with other persons. This may be shown by the books of account, by the testimony of clerks, agents, and other persons, by letters, and admissions, etc.

A general partnership is the relation as it ordinarily exists. A special or limited partnership is composed of general partners, to whom all the ordinary rules of partnership apply, and of limited partners with circumscribed power and liability limited to the amount of their contribution. This kind of partnership is statutory, and the requirements of the statute as to advertisement, placing the list of partners in a conspicuous position at the place of business, indicating which are general and which special, must be strictly complied with. The penalty for non-compliance therewith is to have the association declared a general partnership.

A "partnership limited," also statutory, is in the nature of a corporation, no liability being incurred by the members beyond the amount of their subscription, the penalty for a violation of the requirements of the statute being the same as in the case of a special partnership. Joint-stock companies form another class of partnerships. They consist of a large number of persons, whose liability as a general rule is that of a general partner, though in some instances the liability is limited by the provisions of the statute.

A quasi-partnership may be created by a man holding himself out as a partner, without having any connection with the business or interest therein; in such case he is estopped to deny his liability as a partner. Holding oneself out as a partner is a question of fact. It may be by direct assertion, or by authority given to a partner to use the stranger's name. It may also occur by reason of failure on the part of a stranger to forbid the use of his name; it is usually proved by evidence that the stranger suffered the use of his name over the shop-door, in printed notices, bills, advertisements, etc., or that he has done other acts, of whatever kind, sufficient to induce others to believe him a partner. It is essential, however, that the holding out should have been prior to the contract with the third person, as well as the inducement to it.

Partnership was formerly confined to commercial transactions; its scope has been gradually enlarged, however, until it includes associations for all sorts of purposes, *e. g.*, of attorneys-at-law, physicians, etc. At the common law partnerships for trading in land were not recognized, but at the present time, and especially in America, land is largely held by speculators, who are recognized as partners by the law; so with building operations. Farming land on shares, however, has been held to be no partnership.

The partners are presumed to have the same interest

in the stock that they have in the profits. There is sometimes no joint stock, as where the partnership is merely for the managing and disposing of the goods of others. A partner may contribute but the use of his capital, retaining full control of the principal; and he may charge interest for its use, whether profits are earned or not. The partnership property has been said to consist of the original stock, together with the additions made to it in the course of trade. Real estate bought with partnership funds is treated as partnership property, whether the legal title thereto is in all the partners or only in one. Leases of real estate by one partner for firm purposes, mines, and trademarks have been held to be partnership property.

A partner cannot convey land belonging to the firm; his grantee in such case would take title subject to the rights of the copartner to have the firm property applied to the partnership debts. It has been held in some cases that there was an equitable conversion of land belonging to a partnership, and that it should be treated in every respect as personality.

In administering bankrupt partnership estates the firm and separate creditors have priority upon and are confined to the firm and separate funds respectively. A surplus upon a separate fund is divided among the firm creditors *pro rata*; a surplus upon a firm fund is divided among the separate creditors of the various partners in proportion to the shares of the partners therein. If there is no firm fund the firm creditors come in on an equal footing with the separate creditors against the separate estate. If, however, there is no separate estate, separate creditors cannot participate in the firm estate, upon the theory of the partner's right to have firm funds applied first to the payment of firm debts. It has been held that insolvent partners may divide the firm fund, in proportion to each one's interest in the firm, among their separate creditors, and the firm creditors cannot object; *contra*, however, if the fund were assigned to the separate creditor of one partner only.

A separate judgment is not a lien against the partnership real estate but only against the partner's interest. A judgment against the firm, however, is a lien on a partner's separate estate, and takes priority over a subsequent separate judgment.

While a partnership is presumed to be at will, it may be entered into for a definite term by agreement, express or implied. If a partnership be continued by express or tacit consent after the expiration of the prescribed period it will be presumed to continue on the same terms, but as a partnership at will. A partnership for a specified term is, nevertheless, dissolved by a death within the term. While executors and testamentary trustees may be admitted, either under an original agreement or by testamentary direction, to a partnership, yet it has generally been held that such clauses gave them the option to become partners, and did not constitute them such absolutely. Only the fund already invested or directed to be invested by the testator is subject to the claims of new creditors, unless there be a clear direction to charge the general assets. In England, if an executor undertakes to participate in the business, whether in carrying out a testamentary direction or not, he becomes personally liable as a partner, in addition to the liability of the estate. In several of the United States, *inter alia*, Alabama, Maryland, and Pennsylvania, however, the executor has been held liable only when continuing in the business of his own motion, and not when doing so in carrying out a testamentary direction.

Dissolution of Partnership.—A partnership may be dissolved (1) *by the act of the parties*, as by their mutual consent. Where no limit is fixed for its continuance either party may dissolve it at any time. There are authorities on both sides of the question whether one partner can dissolve a partnership for a certain term previous to its expiration; (2) *by the act of God*, as by the death of one of the partners, unless there be an

express stipulation to the contrary. In such case the partnership is dissolved as to the whole firm; (3) *by the act of law*, as by the bankruptcy of one of the partners; (4) *by a valid assignment* of the partnership effects for benefit of creditors. The mere insolvency of one or all partners without suspension or judicial process does not of itself operate as a dissolution; (5) *by the civil death* of one of the partners; (6) *by the breaking out of war* between two states in which the partners are severally domiciled and carrying on trade; (7) *by the marriage of a feme sole partner*; (8) *by the extinction of the subject-matter* of the joint business, or by the completion of the business for which the partnership was formed; (9) *by the termination* of the period for which the partnership was formed; (10) *by the assignment* of the whole of one partner's interest either to his copartner or to a stranger; (11) *by the award of arbitrators* appointed under a clause in the partnership articles.

A dissolution of a partnership for a term will be decreed by reason of fraud or gross misconduct of a partner, or gross carelessness and waste on his part in administering its affairs, or violent and lasting dissensions among the partners, or the hopeless condition of the business, its continuance being impracticable, and the property liable to be wasted and lost. Clear evidence of a partner's lunacy will also induce a court to decree a dissolution.

Actual notice of dissolution must be brought home to persons who have been in the habit of dealing with the firm; but as to persons who have had no previous dealings with the firm notice in the newspapers is sufficient. This notice is necessary to terminate the agency of each partner, and his powers and liabilities as such. When the dissolution takes place by operation of law, or by the death of a partner, notice is not necessary.

The effect of dissolution is to terminate all transactions between the partners except for winding up the concern, and to absolve the partners from all liability for future transactions of the firm. The power of the partners subsists, however, for some purposes, as for the completion of all unfinished engagements of the partnership; the conversion of the assets for the benefit of the partners; the application of the partnership funds to the payment of the partnership debts.

(T. R.)

PARTON, JAMES, a popular author, was born at Canterbury, England, Feb. 9, 1822, but was brought to the United States when five years old. He was educated in the vicinity of New York, and after being a teacher for seven years became a contributor to the New York papers. His first work, *The Life of Horace Greeley* (1855), contained fulness of research with an enthusiastic picturesque narrative. It has been enlarged in subsequent editions and long remained popular. After completing *The Humorous Poetry of the English Language* (1857) he prepared *The Life of Aaron Burr* (1859), which possessed much of the merit of his first work, but was too partial to its subject. In the appendix to a later edition (1865) many statements of the first are recalled. Parton had in the meantime published a bulky *Life of Andrew Jackson* (1860), which showed equal diligence in hunting information from obscure sources and great skill in its presentation. His next biography was that of *Benjamin Franklin* (1864), which gave him room for his love of anecdote and sketching of character. His story of *Gen. Butler in New Orleans* (1863) skillfully presented the facts of the restoration of Union rule to a city in which the spirit of the Southern Confederacy was dominant. After the war Parton took up various social topics which he discussed in magazines and reviews in an entertaining and popular style. To this series belong *Smoking and Drinking*, *How New York City is Governed*, *the Work of Congress*, *Roman Catholics and Jews*. In the *Triumphs of Enterprise, Ingenuity and Public Spirit* (1871) he presented the story of the most remarkable

inventions of modern times. Another skilful compilation is *Caricatures in all Times and Lands* (1876). Parton's best work, however, is in his biographies. *Famous Americans of Recent Times* (1867) is a collection of brief sketches, but his *Life of Jefferson* (1876) and *Life of Voltaire* (1883) are elaborate works with his characteristic excellencies. Parton is a man of the people with the gift of story-telling. He cares little for poetic genius, statecraft, or religion, and misses no opportunity of deriding those whose station is due to other causes than personal merit.

His wife, SARA PAYSON PARTON (1811-1872), was the sister of Nathaniel P. Willis. She was twice married, but, being reduced from affluence to poverty, tried to support herself and two children by teaching and afterwards by writing for the newspapers. Under the pseudonym "Fanny Fern" she gained a remarkable popularity. Of her *Fern Leaves* (1853) several series were issued. She also published two novels, *Ruth Hall* (1857) and *Rose Clark* (1859). She was married to Mr. Parton in 1856 and after her death he published *Fanny Fern, a Memorial Volume* (1873).

PARTRIDGE is a term used scarcely less loosely by ornithologists than by others, and its meaning depends upon circumstances. See Vol. XVIII. p. 332 (p. 337 Am. Rep.). Its newest technical equivalent is *Pedicularia*, by which is meant a subfamily

of the grouse family, *Tetraonidae*, containing several genera and many species of gallinaceous game-birds of most parts of the world (especially the northern hemisphere), which average less in size than grouse and have the nasal fossæ and the feet bare of feathers. Many of these birds have a characteristic note which the word "partridge" in its several forms seems to have been invented or designed to express.

In Britain the only indigenous partridge is that sometimes designated as the gray partridge (*Pedicularia cinerea*) to distinguish it from another bird, *Caccabis rufa*, which has been introduced and naturalized there. (For these as well as some other old-world species of the above-named genera and others, see the article in the *ENCYCLOPÆDIA BRITANNICA*.)

In English-speaking parts of the old world the partridges of whatever kind are commonly distinguished both from the grouse and from the quail, of both of which there are various species and genera. But in the United States the case is the reverse, for some grouse are indifferently called "pheasant" and "partridge," and various birds are indifferently called "partridge" and "quail." It is an example of that confusion which arises in nomenclature when the names of animals and plants of one country are loosely applied to other more or less similar animals of another country.

For, it must be distinctly understood that no gallinaceous bird whatever, excepting certain ptarmigan of the Arctic regions, is common to Europe and America. Attempts have been made to introduce the European or migratory quail, *Coturnix dactylisonans*, but they have hitherto failed.

In the Eastern United States two very different birds are called "partridge." One of these is the ruffed grouse, *Bonasa umbellus*. The other is the bob-white, *Ortyx* or *Colinus virginianus*. (See *BON-WHITE*.) Throughout the Northern States, where this grouse is called partridge, the bob-white is known as the "quail." In the Middle and Southern States, or from Pennsylvania southward, this grouse is called pheasant, by an absurd misnomer; and wherever this name prevails, there the bob-white is called "partridge." Thus we have three popular names for the two birds, whose application changes with the locality. These two are the only gallinaceous game-birds that are common and widely distributed in eastern parts of the United States. In the West there are several others, as the pinnated grouse or prairie-hen, *Cupidonia cupido*; the sharp-tailed grouse, *Pedicularia colum-*

binnus; the sage grouse or cock of the plains, *Centrocercus urophasianus*; the dusky grouse, *Canace obscurus*, etc. The last-named is a near relative of the Canada grouse, *Canace canadensis*, which is often called the "spruce partridge," making yet another bird to share this latter name.

Then, in south-western parts of the United States and in Mexico and southward are several different genera and species of birds about as large as the bob-white, all called indifferently "partridge" or "quail." Such are the mountain quail of California, *Oreortyx pictus*, with a long arrowy crest; the valley quail of California, *Lophortyx californica*, with



California Valley Quail.

an elegant recurved helmet-like crest; the very similar Arizona partridge or quail, *Lophortyx gambeli*; the blue or scaled partridge or quail, *Callipepla squamata*; and the very handsome Massena partridge or quail, *Cyrtonyx massena*. Moreover, the common Virginia partridge, quail, bob-white, or colin runs into several varieties in Florida and in Texas; and a distinct species of the same restricted genus *Colinus*, *C. ridgwayi*, has been lately ascertained to inhabit Arizona. Mexico and Central and South America also furnish yet other species of *Colinus*, *Dendrortyx*, *Odontophorus*, etc., all of which birds may be indifferently called quails or partridges.

All these small gallinaceous game-birds of America with naked and scaly tarsi (as distinguished from the feathered shanks of grouse and ptarmigan) are sometimes grouped together as a subfamily, *Odontophorinae* or *Ortyginae*, which has no representatives outside of America. (E. C.)

PASSAGLIA, CARLO (1812-1887), Italian theologian, was born at San Paolo, near Lucca, May 12, 1812. He was educated at Rome and became a Jesuit in 1827. He taught in the Roman College until 1858, when he left the Jesuit order and was made professor in the College of Sapienza. He was active in the movement which led to the proclamation of the dogma of the Immaculate Conception of the Virgin Mary.

He afterwards addressed a letter to the bishops of Italy on the claims of Italian unity and urged the pope to renounce his temporal power. But his pamphlet was placed on the Index, and the author was obliged to flee from Rome in disguise. He had just published anonymously two other pamphlets, one on the duty of the pope to reside in Rome, the other on the limits of excommunications. He was made professor of moral philosophy in the University of Turin and soon issued another pamphlet on schism. He formed an association of the liberal clergy of Italy and was elected to the national parliament in 1863. His political career was short, and finally in 1882 he submitted to the Holy See and was restored to his priestly functions. He died at Turin, March 17, 1887.

PASSAIC CITY, in Passaic co., N. J., is at the head of tide-water on the Passaic River, 11 miles N. W. of New York city, on the Erie, the Delaware, Lackawanna, and Western, and the New York, Susquehanna, and Western Railroads. It is well laid out with macadamized streets, has 14 churches, 5 schools, 2 daily and 2 weekly newspapers, several halls, is lighted with gas and well supplied with water. It has two iron-foundries, and manufactures of woollen goods, chemicals, India-rubber, whips, and other goods. Many of the inhabitants conduct business in New York city. The population was 6532 in 1880, and has since increased.

PASSOVER. See **TABERNACLE**.

PASTEUR, LOUIS, a French chemist, was born at Dôle, Dec. 27, 1822. He had spent some years in teaching physical science at Besançon and at Paris before he received the doctor's degree from the Normal School in 1847. He was then made professor of chemistry at Dijon, and a few months later at Strasburg. In 1854 he was appointed to organize the new faculty of science at Lille, and in 1857 he returned to Paris to take charge of the scientific instruction in the Normal School. Here he remained ten years, being also from 1863 professor of geology, physics, and chemistry in the school of the Fine Arts. From 1867 to 1875 he was professor of chemistry at the Sorbonne, and there retired on a pension, his sight and health having been seriously impaired by his arduous labors. His chemical investigations and their practical results had already given him world-wide fame. In 1856 he received from the Royal Society of London the Rumford medal for his researches on the polarization of light, and in 1874 the Copley medal. From the outset of his career he has been an ardent opponent of the theory of spontaneous generation, which was advocated by many scientists. He maintains that fermentation is always due to microscopic plants or animalcules, and that it can be prevented by carefully excluding their germs from access to the fermentable substance. His conclusions have had important consequences on the manufacture of wine and beer. Their scientific and commercial value was recognized by the French and other governments, which awarded him prizes and pensions. His investigations of the diseases of the silk-worm were also extremely valuable to the silk industry of France. He traced the disease to certain minute internal corpuscles and pointed out the method of prevention. (See **GERM THEORY**). For some years he had directed his investigations towards the discovery of a specific germ for each disease of man or the lower animals. Other investigators had also joined in the researches and the discovery of several such germs has been reported in recent years. None has produced such sensation, however, as Pasteur's claim to have found not only the true nature of hydrophobia but also the method of preventing it by inoculation. (See **HYDROPHOBIA** and **BACTERIA**.) Pasteur's researches have been reported in the *Annales de Chimie et de Physique* and other publications. He has also published treatises on wine (1866), vinegar (1868), silk-worms (1870), beer (1876), microbes (1878).

PASTORAL EPISTLES is the name applied to three epistles in the New Testament (two to Timothy and one to Titus), written by the Apostle Paul near the close of his life; 2 Timothy bearing every mark of being the last epistle penned. (Philemon, though placed with the pastoral epistles in our Bibles, is not to be classed with them, since it was written at the same time with the Epistles to the Ephesians and Colossians. Philem. 10; Col. iv. 7, 9; Eph. vi. 21.)

The difficulties connected with these epistles have been set forth in the previous article, and the impression given that the Pauline authorship is improbable. "The majority of modern critics," it is asserted, "question or deny their authenticity," that is, their genuineness. But this assertion holds good only in the case of a certain school of critics. The difficulties have not led to a rejection of the epistles by any considerable portion of Biblical scholars, and the argument in favor of the genuineness is a very strong one.

The three letters stand or fall together. Every attempt to prove one of them Pauline and the others forgeries has failed from its inherent inconsistency. It has been fully shown by Dr. Hatch that they cannot be placed at any period in the life of the apostle up to the close of the two years named in Acts xxviii. 30. Yet he somewhat summarily disposes of the theory that they were written by the apostle, "subsequent to the close of the Acts of the Apostles." Most of those who accept these epistles as genuine hold that Paul was released from his imprisonment at Rome, and after a brief period of freedom was reimprisoned and beheaded. On the other hand, those who deny their genuineness object to this theory; indeed, the theory is frequently objected to, in order to deny the genuineness of the epistles. The controversies of this century have virtually narrowed the question to this single point, which is more probable, that Paul lived for some years after the time when the Book of Acts closed its narrative, or that these epistles are forgeries? The former is exceedingly probable, the latter equally improbable. As the improbability of the former and the probability of the latter have been fully set forth in Dr. Hatch's article, the other side should be stated here.

1. The probability that the Apostle Paul lived for some years after the time at which the Book of the Acts closes. (1) The patristic evidence, while open to discussion, is positive. The objections raised against this evidence do not weaken its force respecting the main point, namely, that the apostle was set at liberty after the two years' imprisonment at Rome, and made another missionary journey before his death. The silence of other early writers about this journey is not evidence. (2) The Book of Acts terminates in an abrupt manner, making no allusion to the death of the apostle. It therefore presents no evidence on the matter in question. But this silence respecting the martyrdom of the apostle is unaccountable, if that martyrdom took place at the time when the narrative closes. If, however, the apostle lived and labored for a few years after that time the conclusion of the Book of Acts is natural enough. The evangelist wrote it during the two years at Rome, and it was in circulation while the apostle was still alive. Even if it were written after his death, that fact would probably have been mentioned if it occurred at the time when the narrative closes. On the other hand, if a number of other events occurred in the later history of Paul the historian would omit all of them, because his purpose was accomplished, that of showing the establishment of Christianity in its new centre at Rome. This is "conjecture," not "evidence," but (3) the entire argument against the second Roman imprisonment rests upon "conjecture" rather than "evidence." It is urged by the critics who oppose this theory that Paul would have alluded to the Neronian persecution in the

pastoral epistles had he written these after that persecution began. But his silence is not so singular as the silence of the author of the Book of Acts about the death of Paul, if that occurred at the time the opponents of this theory claim. No positive historical statement can be adduced against the fact of a second Roman imprisonment. The internal evidence from the epistles themselves is constantly used to prove a later date than that of the other Pauline epistles. This is valid enough. But this evidence does not compel us to accept a date later than that allowed by the theory of a second imprisonment. Only by pressing terms and statements beyond their necessary meaning can a plausible argument for a sub-apostolic date be presented. Until the epistles are proven forgeries they themselves are competent witnesses as to the facts of the apostle's history. Those who accept them as competent witnesses rarely find a serious difficulty in constructing a consistent theory respecting the events in Paul's life subsequent to the two years' imprisonment at Rome, and in assigning to these epistles their respective places in that period of his life. The alternative is the spuriousness of the epistles.

2. The improbability of these epistles being forgeries. If spurious, they must be wilful forgeries; for they claim to be Pauline. Their contents include many personal allusions and direct commands, as if from the Apostle Paul. Every attempt to account for them as based upon briefer writings of the apostle has failed. The "patchwork" school of criticism has essayed to do it, but without success. As regards the genuineness of the pastoral epistles, the following statement must suffice: (1) The epistles have been well-nigh universally accepted as Pauline, and are included in the earliest lists of New Testament writings, as well as cited by very early fathers. (2) No motive for forging such epistles can be discovered, either in their contents or in any circumstances of the early church to which the contents would be pertinent. (3) As in the case of other epistles which have been doubted, no author can be found who could have written such epistles. The second century produced few Christian authors of mark. The works remaining to us are of a character so much below that of the Pauline epistles, these included, that one cannot even by "conjecture" hit upon an author. The contrast with the *Teaching of the Twelve Apostles* and the *Epistle of Barnabas* is obvious. Yet we are asked to believe that these epistles came into existence in the same age with these latter. (4) The historical difficulties themselves furnish an argument against the spuriousness of the epistles. A forger skillful enough to personate Paul so successfully as to deceive the church for 1800 years would have been skillful enough to make his historical allusions fit into the narrative of the Book of Acts. Nor is it improper to suggest that such a forger would hardly have taken pains to invent the incident about "the cloak at Troas" (2 Tim. iv. 13), and other minor details. (5) The objections raised on internal grounds have been repeatedly answered. (a) As to the contents, the pressing of "doctrine" is not singular. "Teaching" is meant, and these epistles were written to men who were organizing churches and superintending the induction of teachers into office. The errors combated are not necessarily those of a later period of the church than that usually assigned as the date of these epistles. The early and rapid growth of error is indicated in the undoubted Pauline epistles. Nor can there be found any particular age or error in the church, after the apostolic period, to which the language of these epistles would apply with such force as to suggest a forgery to meet that error in that age. (b) The objections from the peculiar words and the more simple style of the epistles amount to little. The purpose of the letters necessarily led to the use of words not pertinent in the other epistles. Arguments from the use of words are always precarious. Then, as to style; the involved structure so common in the other Pauline

epistles is absent here. It is the practical missionary who is speaking, advising, and exhorting his younger brethren. How far this modifies style every one knows who has attempted it. Huther remarks on this difference of style, but only to defend the genuineness. (c) The historical difficulties are met by the theory of a release from imprisonment at Rome and a subsequent reimprisonment, during which the last of the pastoral epistles (2 Timothy) was written. This allows sufficient time for the development of church organization and of error which the epistles indicate. For example: according to this theory 1 Timothy was addressed to Ephesus about A. D. 63. In A. D. 58 the church had a body of elders, and these are warned against the impending danger of erroneous teaching (Acts xx. 17-31). The five years' interval is long enough for the implied development. (6) The internal evidence of Pauline authorship is very strong. The personal allusions are not only frequent, but of such a character as to reveal the same great heart that manifests its presence in the Epistles to the Romans and Corinthians. Allusion has already been made to the minute details which indicate the genuineness of the epistles. It seems impossible to discuss the bearing of internal evidence with one who could believe that 2 Tim. iv. 6-8 was written by a forger, posing as the Apostle Paul.

3. While there are differences of opinion in regard to some details of the theory of a second Roman imprisonment, the following summary presents the main points of the apostle's life after the first Roman imprisonment, accepting the pastoral epistles as genuine and historically accurate. He was probably released from prison in A. D. 63, before the persecution under Nero began (A. D. 64). His first journey was probably to Ephesus, where he left Timothy (1 Tim. i. 3), proceeding thence to Macedonia, where 1 Timothy was written. His next journey was to Crete, passing through Troas and Miletus. In Crete Titus was left (Tit. i. 5), as Timothy had been in Ephesus. Their work was that of missionary superintendents, not that of local "bishops." How long they remained in this labor is not known. During this interval of freedom Paul seems to have spent a winter at Nicopolis (Tit. iii. 12) after writing the Epistle to Titus. Of further journeys we have hints in the Fathers, but no definite historical traces. He was rearrested, and during this imprisonment wrote a second letter to Timothy. Shortly afterwards he was beheaded at Rome, but the date is variously assigned between A. D. 66 and 68.

See further in article PAUL. The whole question is fully discussed in Schaff's *History of the Christian Church* (new ed., vol. i., pp. 798-808). (M. B. R.)

PATENTS. Previous to the Declaration of Independence patents were occasionally granted to individuals by the British colonial governments in North America. This power was exercised by the General Court of the colony of Massachusetts as early as 1641. In 1652 Connecticut in a statute prohibiting monopolies also provided for granting patents for new and beneficial inventions for such times as the General Court should deem meet. Such patents were, however, rare and our information in regard to them is vague and indefinite.

After the close of the revolutionary war there was considerable activity among American inventors, especially with regard to the application of steam-power to vessels and machinery of various kinds. (See EVANS, OLIVER.) The States of New York, New Jersey, Pennsylvania, Maryland, and Virginia granted to inventors whose projects seemed to promise success monopolies of navigating their waters with the aid of steam. The conflicting claims of inventors under powers derived from the State authorities had an influence in leading the Constitutional Convention in 1787 to incorporate among the powers of the general government that of granting patents.

By Art. I., sec. 8, of the Constitution of the United

States power was vested in Congress "To promote the progress of science and useful arts by securing for limited times to authors and inventors the exclusive right to their respective writings and discoveries."

It is upon this provision that our copyright and patent laws are based. The first Congress in 1790 passed an act regulating the issue of patents for inventions. By its provisions the inventor was required to present a petition to the secretary of state, the secretary of war, or the attorney-general, setting forth the nature of his invention and asking for a patent. If this was approved by the above-named officers or any two of them the description of the invention was certified to by the attorney-general and the issuing of the patent was directed by the President. It was recorded in the office of the secretary of state and by him delivered to the patentee or his agent under the great seal of the United States.

Various other statutes were enacted subsequently, but the essential features of the law remained unchanged until 1836. Patents were granted on application with little or no scrutiny, and the duty of deciding whether the patentee was justly entitled to a patent was devolved wholly upon the courts. Hardly any attempt was made to prevent the issuing of a patent upon insufficient grounds. The interests of the public were supposed to be sufficiently protected by allowing the validity of the grounds upon which the patent was granted to be called in question at any time in case of a suit for infringement. After an experience of nearly half a century the inconvenience and injustice of this system had become manifest.

In 1836 the Patent-office was burned and many of the records destroyed. Congress embraced the opportunity to thoroughly revise the whole system. By an act passed in that year prior acts were substantially repealed and the present system substituted.

As at present organized the Patent-office is attached to the department of the secretary of the interior. It consists of the following officers: One commissioner, one assistant-commissioner, and three examiners-in-chief, all appointed by the President by and with the advice and consent of the Senate. All other officers, clerks, and employes are appointed by the secretary of the interior on the nomination of the Commissioner of Patents: they are: One chief-clerk, one examiner in charge of interferences, one examiner in charge of trade-marks, 24 principal examiners, 24 first assistant-examiners, 24 second assistant-examiners, 24 third assistant-examiners, one librarian, one machinist, 3 skilled draughtsmen, 35 copyists of drawings, one messenger and purchasing clerk, one skilled laborer, 16 attendants in the model-room, one examiner of designs. The combined salaries of these officers amount to \$261,200 per annum. The principal object of the great force of examiners above mentioned—one hundred in all—is to prevent the granting of patents for alleged inventions which are really not new and useful, and so to prevent individuals from acquiring a monopoly of inventions and improvements to the use of which the public were already entitled.

The general principles of the law of patents are the same in this country and in England. Among the peculiarities of the patent laws of the United States it may be mentioned that the term for which they are granted, seventeen years, is longer than in any other country. The development of the patent system in the United States far exceeds that of any other nation. For several years the number of patents issued in the United States has been nearly equal to the number issued by all other civilized nations together. A pamphlet containing the *Patent Laws and Laws relating to the Registration of Trade-marks and Labels*, and one containing the *Rules of Practice in the United States Patent-Office* are published by the office and can be obtained free of charge by any one desiring them on application by mail to the Commissioner of Patents. It is, however, practically impossible for an inventor

himself to prepare the papers, drawings, etc., necessary to obtain a patent, with the requisite degree of scientific and technical skill. "Patent lawyers" form a distinct branch of the profession and the inventor will find it in the end the cheapest as well as the surest course to intrust his case to an attorney who makes the practice of patent law a specialty. In a simple case, when no difficulties are encountered, and everything goes through in regular order under the direction of a reputable attorney, the cost of obtaining a patent may be stated as follows: Government fee on filing application, \$15; government fee on issuing patent, \$20; attorney's fee, \$25; making the total charge \$60. This may be regarded as the minimum of expense for securing a patent. But where the invention is of a complicated character, requiring great skill and care in the preparation of the descriptions and drawings, where difficulty is experienced on account of anticipatory inventions, real or alleged, where the application is rejected by the primary examiners and it becomes necessary to appeal from them to the board of examiners-in-chief, from these to the commissioner of patents, and from the commissioner to the Supreme Court of the District of Columbia, the expense will depend upon the circumstances of each case.

Owing to the destruction of the records of the Patent-office in 1836, the reconstruction of the history of invention in the United States previous to that year would involve a great amount of laborious and painstaking investigation and research. From that year to the present time the records are complete and accessible, and the number of patents granted in each succeeding decade may, perhaps, be taken as a fair index of the fertility of American inventive genius and the progress of American industries. The first patent granted after the reorganization of the Patent-office under the act of 1836 bears date July 28th of that year, and is No. 1 of the present enumeration. From that date up to and including the year 1846 the number of patents issued was 5019. During the next ten years ending with 1856, inclusive, the number of patents issued was 12,578. The ratio of increase was from 572 issued in 1817 to 2502 issued in 1856. During the decade ending with and including the year 1866 the number issued was 41,334. The number issued in 1857 was 2685, and in 1866 it was 8873. During the decade ending with and including the year 1876 the number issued was 125,155. The number issued in 1867 was 13,015, and in 1876 it was 12,870. This period of 10 years, 1867-76, is the only one in which the number of patents issued in the first year of the decade was greater than the number issued in the last. During the decade ending with and including the year 1886 the number of patents issued was 169,478. The number issued in 1877 was 13,117, while in 1886 the number was 21,796. During the year 1887 the number issued was 20,428.

The whole number of patents issued from July 28, 1836, up to and including Oct. 16, 1888, was 391,395. This is exclusive of what were termed "additional improvements," which were additions to original patents permitted under provisions of the act of 1836, which remained in force until the act of 1860. It is also exclusive of reissues, which down to the date mentioned, Oct. 16, 1888, numbered 10,963. It is also exclusive of "design patents," which down to the same date numbered 18,690.

Down to the year 1887 the number of patents issued to foreign inventors was 1466; the nationalities and numbers were as follows: English, 500; Canadian, 294; German, 291; Scotch, 28; Belgian, 35; and 1 each to citizens of Corea, Japan, Luxembourg, and Syria. If we take the year 1880 as an example, and compare the ratio of patents to population in the different States and Territories, the following are the highest and lowest results: in Connecticut, one patent to every 790 of the population; in the District of Columbia, 1 to every 895; in Massachusetts, 1 to every

950. The lowest ratio of patents to population was in Mississippi, 1 patent to every 25,146 of population; the next in Alabama, 1 to every 23,379; and the next in North Carolina, 1 to every 21,208.

The Patent-office is a self-supporting institution. There have been only eight years, the last of which was 1861, during the last half-century when the receipts did not exceed the expenditures. The receipts in 1837 amounted to \$29,289.08. During the year 1887 the receipts were \$1,144,509.60, the expenditures were \$994,472.22, leaving a surplus to the credit of the office of \$150,037.38 for that year. In many previous years the surplus has been much greater. The rooms of the Patent-office are notoriously overcrowded to an extent that is injurious to the health of the employes, and inconvenient both to them and the public in the transaction of business, notwithstanding the fact that the inventors of the country have paid a tax defraying all the expenses of the office and leaving a surplus many times exceeding what would be necessary to make much needed reforms. (W. M. F.)

PATERSON, a manufacturing city of New Jersey, the seat of Passaic co., is situated on the Passaic River, 16 miles from New York city, on the Erie, the Delaware, Lackawanna, and Western, the New York, Susquehanna, and Western, and the Paterson, Newark, and New York Railroads. The Passaic River, which flows through the city, and is crossed by many bridges, is noted for its falls, which furnish abundant water-power. The industrial establishments comprise a rolling-mill, three locomotive-works, a large iron-forge, numerous cotton- and paper-mills, but above all, 116 silk-mills, which give the city its distinctive place among the manufacturing cities of America. There are 5 hotels, 2 national banks, a savings bank, 5 daily and 9 weekly newspapers, 14 public schools, and good private schools, 2 hospitals, 2 orphan asylums, and some 50 churches. The city was settled in 1792, being named after Gov. William Paterson, who signed the town charter, and incorporated as a city in 1854. It is well laid out, is lighted with gas, and has water-works. The total debt in 1886 was over \$2,130,000, and the yearly expenses nearly \$1,189,000. The population in 1880 was 15,031.

PATMORE, COVENTRY KEARSEY DEIGHTON, English poet, was born at Woodford, Essex, July 23, 1823. At the age of 21 he published a volume of poems which attracted little attention. From 1846 to 1868 he was one of the assistant librarians of the British Museum, and in the meantime published the domestic poem, by which he is best known, *The Angel in the House* (1854-62). This work consists of four parts—*The Betrothal*, *The Espousal*, *Faithful for Ever*, and *The Victories of Love*. It is the most successful attempt to depict the poetic aspects of married life. Patmore has also published *A Garland of Poems for Children* (1862); *The Unknown Eros* (1877); a *Memoir of Barry Cornwall* and *Amelia* (1878). In later life he became a Roman Catholic.

PATON, SIR JOSEPH NOEL, a Scotch painter, was born at Dunfermline, Dec. 13, 1821. He studied his art in the Edinburgh Academy and the Royal Academy, London. In 1844 he exhibited at the Royal Scottish Academy his first painting, *Ruth Gleaning*. In the next year he obtained at Westminster Hall, London, a prize for a fresco of *The Spirit of Religion*. In 1847 his large oil-painting of *Christ Bearing the Cross* and a small one representing *The Reconciliation of Oberon and Titania* were jointly awarded a prize of £300. The latter picture was purchased for the Scottish National Gallery, which also obtained its companion picture, *The Quarrel of Oberon and Titania* (1846). He has also taken delight in allegorical subjects, among which are *The Pursuit of Pleasure* (1855); *Mors Janua Vitæ* (1866); *Faith and Reason* (1871); *The Spirit of Twilight* (1876). Of his paintings of religious subjects may be noted *Christ and Mary at the Sepulchre* (1872); *The Man of Sorrows* (1875), and *Christ*

the Good Shepherd (1876). He has published outline etchings of Shakespeare, Shelley, and other poets. The works of the great poets have also furnished subjects for his paintings. A ballad of the Scottish border, "The Dowie Dens of Yarrow," has been illustrated by a series of six pictures. He was made Queen's Limner for Scotland in 1866, was knighted in 1867, and in 1876 received the degree of LL.D. from the University of Edinburgh. He has published two books, *Poems by a Painter* (1862) and *Spindrift* (1866). His brother, Walter Paton, born in 1825, has some note as a landscape painter.

PATRICK, MARSENA R. (1811-1888), general, was born at Houndsfield, Jefferson co., N. Y., March 15, 1811. He graduated at West Point in 1835 and served in the Mexican war, being made captain and brevet-major. He resigned in 1850 and in 1859 was made president of the New York State Agricultural College. The outbreak of the civil war in 1861 called him again to arms, and he was made inspector-general of militia. In 1862 he served with the army of the Potomac and fought at Antietam. He then was made provost-marshal-general of that army, and afterwards of all the armies operating against Richmond. He resigned in 1865 and was afterwards president of the New York State Agricultural Society. In 1880 he was made governor of the Soldiers' Home, Dayton, Ohio, and died there Aug. 5, 1888.

PATRONS OF HUSBANDRY. See GRANGERS.

PATTERSON, CARLILE POLLOCK (1816-1881), superintendent of the Coast Survey, was born at Shieldsborough, Mass., Aug. 24, 1816. He was the son of Capt. Daniel Tod Patterson, U. S. N. (1786-1839), and entered the navy in 1830 as a midshipman. After serving five years in the Mediterranean he returned to pursue an engineering course in Georgetown College. In 1838 he entered on the work of the coast survey, but also had navy service occasionally until 1850, when he became captain of a Pacific mail steamer. In 1861 he resumed work in the Coast Survey and in 1874 he was made superintendent. Under his administration the work was enlarged to be a general geodetic survey. He also assisted in other departments of the naval service, and was for many years a member of the lighthouse board. He died at Washington Aug. 15, 1881. His only writings were *Reports* of his work.

PATTERSON, ROBERT (1792-1881), general and manufacturer, was born at Cappagh, Ireland, Jan. 12, 1792, but was brought at an early age to Pennsylvania. In the war of 1812 he was a first-lieutenant, and afterwards engaged in manufacturing and in local and State politics. In the Mexican war he was major-general of volunteers and served with Gen. Scott, fighting at Cerro Gordo and capturing Jalapa. On the outbreak of the civil war Patterson entered the service with the three-months volunteers and had charge of a military department extending from Pennsylvania to Washington. Having crossed the Potomac at Williamsport on June 15, he was instructed to watch Gen. J. E. Johnston's force at Winchester, while Gen. McDowell advanced from Washington. Johnston, however, joined Beauregard, and McDowell was thus defeated. Patterson was greatly blamed, but asserted that he had been directed to wait for orders from Washington, which never came. His commission expired July 27, 1861, and he retired to private life. He published a *Narrative of the Campaign in the Shenandoah* (1865). He continued active in business until his death, Aug. 7, 1881.

PATTERSON-BONAPARTE. See BONAPARTE.

PATTI, ADELINA, singer, was born at Madrid, Feb. 19, 1843. Her father and mother were Italian musicians, and she was taught in childhood by her brother, Signor Barilli. At the age of seven she made her first appearance at a concert and soon earned enough to secure thorough musical training. In November, 1859, she appeared in New York as Lucia and achieved the highest success as a singer and actress.

In 1861 she went to London, in 1862 to Paris, and thereafter appeared in all the European capitals. In England and the United States she has frequently appeared in concert, as well as in opera. She was married to Marquis de Caux, a French nobleman, in 1868, but was divorced in 1883, and in 1886 was married to Ernesto Nicolini, an operatic singer.

Her sister **CARLOTTA** was born at Florence in 1840, and was early trained for the stage. A slight lameness interfered with her success in opera, but she became noted as a concert-singer. She had first appeared at New York in 1861, and afterwards went to Europe, where she gave hundreds of concerts. Her voice is a soprano of remarkable range. She was married in 1879 to Ernst de Munch.

PATTISON, MARK (1813-1884), English author and educator, was born at Hornby, Yorkshire, in 1813. His boyhood was spent at Hauxwell, near Richmond, where his father was rector. He was educated at Oriel College, Oxford, graduated in 1836 and was made a fellow of Lincoln College in 1839. Though Newman's connection with Oriel College had ceased before Pattison entered, the whole of Oxford was still permeated by his influence, and Pattison was reckoned among his closest followers. He was ordained priest in 1843 and took some theological prizes, but after Newman's withdrawal from the Anglican Church, Pattison devoted himself steadily to his college duties as examiner and tutor. In 1851 he failed to get the rectorship of Lincoln College, which seemed then his due, and his subsequent life showed the effect of the disappointment. His essay on "The Tendencies of Religious Thought in England," one of the famous *Essays and Reviews* (1860), proved that Newman had had little permanent influence on his mind. Pattison made a *Report on Elementary Education in Germany* in 1859 and at last obtained the rectorship of Lincoln College in 1861. But his former activity in education was gone. Thoroughly a scholar, devoted to research, he wished the endowments of the universities to be used for the promotion of original literary and scientific research. His *Suggestions on Academical Organization* (1867) may have led to the movement which has been partially successful in that direction. His literary work, besides contributions to the *Quarterly* and other periodicals, is to be found in editions of some works of Milton and Pope, and especially in his *Life of Casanbon* (1875). He had originally intended to write a biography of Scaliger, but was diverted from his purpose by learning that Prof. Jacob Bernays had undertaken that subject. In the last months of his life he dictated some *Reminiscences* (1885) in which he pathetically protests against the caricature of himself given in George Eliot's *Middlemarch* and also against the romantic version of his sister's life given in Miss Lonsdale's *Sister Dora*. He died June 30, 1884. His widow became the wife of Sir Charles W. Dilke.

PATTON, FRANCIS LANDEY, theologian, was born in Bermuda, Jan. 22, 1843. He was educated at University and Knox College, Toronto, and studied theology at Princeton. He was ordained to the Presbyterian ministry in 1865, and had charge of churches in New York, Nyack, and Brooklyn. In 1871 he was made professor of didactic theology in the Presbyterian Seminary at Chicago, and he was also editor of the *Interior*, 1873-76. He prosecuted Rev. David Swing, a popular preacher, before the Presbytery of Chicago for heresy, and procured his conviction and suspension. He was moderator of the General Assembly at Pittsburgh in 1878. He became pastor of the Jefferson Park Church in 1879. In 1881 he was called to Princeton Theological Seminary as professor of science and philosophy in their relation to religion. In 1888 he was chosen to succeed Dr. James McCosh in the presidency of Princeton College. He has been a frequent contributor to religious periodicals and has published *Treatise on Inspiration* (1869); *Summary of Christian Doctrine*; *Doctrine of Future Retribution*.

PAUL. The full sketch of the Apostle Paul's life in the *ENCYCLOPÆDIA BRITANNICA* suggests many doubts in regard to the trustworthiness of the New Testament records. But of all ancient historical books there is not one that has been so thoroughly tested as the Acts of the Apostles. The many points of contact with Roman history, Greek usage, and Mediterranean topography furnish sufficient data to establish the accuracy of the writer. As regards the Pauline epistles, the most destructive critics admit the genuineness of four (Galatians, 1 and 2 Corinthians, and Romans). These epistles are in themselves sufficient to show the character and teachings of Paul. They attest the fact that Christianity was widely diffused in A. D. 58. The genuineness of the other Epistles has not been successfully impugned. The objections arise from preconceived theories in regard to the apostolic age. (The Epistle to the Hebrews, of course, occupies an exceptional position. See *HEBREWES*.) The strongest array of probabilities is made against the pastoral epistles, but the objections raised have been answered repeatedly (see *PASTORAL EPISTLES*). The following sketch assumes the authenticity of the narrative in the Acts of the Apostles, as well as the genuineness of the epistles bearing the name of Paul.

1. *Life of the Apostle.*—Saul was born at Tarsus in Cilicia (Acts ix. 11; xxii. 3); he was of the tribe of Benjamin (Phil. iii. 5; 2 Cor. xi. 22), and by birth a Roman citizen (Acts xvi. 37; xxii. 28). He was educated at Jerusalem under Gamaliel (Acts xxii. 3; xxvi. 4, 5). But he seems never to have seen the Lord Jesus during His ministry (1 Cor. vi. 1; xv. 8). This does not invalidate the previous statement about his education, since our Lord's ministry lasted at most only three years and a half. Saul first appears in the Acts of the Apostles as a young man zealous for the death of Stephen, the first Christian martyr (Acts vii. 58; viii. 1). How old he was at this time is uncertain. It is inferred by some from Acts xxvi. 10 that he was a member of the Jewish Sanhedrin, but the "vote" referred to may have been in some lower tribunal. His Jewish zeal seems to have placed him at the head of the persecution that arose after the death of Stephen (Acts viii. 3; ix. 1, 2), and on the way to Damascus as the emissary of the high-priest he was converted to Christ by an appearance of the Lord himself. Three accounts of this occurrence are given in the Acts (ix. 1-19; xxii. 3-16; xxvi. 19-20), and there are many allusions to it in the epistles. Thus his life was transformed, and he never ceased to assert that he had seen the Lord. To deny a real objective appearance on this occasion is to assert that Paul was either a deceiver or himself deceived. The date of this conversion is probably A. D. 37 (see below).

The completeness of the change is emphasized in all the narratives, and the conversion seems to have been regarded by Saul himself as a call to the apostleship. He at once began to preach at Damascus (Acts ix. 19, 20), but soon retired to Arabia (Gal. i. 17), spending the larger part of three years in quiet preparation. Returning to Damascus, he met with persecution from the Jews (Acts ix. 23, 25; 2 Cor. xi. 32, 33), but escaped to Jerusalem, where the disciples seemed doubtful respecting him (Acts ix. 26), but Barnabas befriended him.

This visit to Jerusalem is, for convenience, called the "first," and the date was about A. D. 40. It lasted for fifteen days (Gal. i. 18); during which he received a direct revelation of his mission to the Gentiles (Acts xxii. 17-21). He met the Apostle Peter and James, the Lord's brother, but his knowledge of the gospel was not derived from them (Gal. i. 11, 19). Driven away by the enmity of the Jews, he goes to Tarsus, and afterwards was brought to Antioch by Barnabas, with whom he made his "second" visit to Jerusalem

(A. D. 44), bearing alms from the disciples in the former city (Acts xi. 25-30).

Shortly after (A. D. 45), under the special direction of the Holy Spirit, given through the church at Antioch, the apostle begins his recorded missionary activity, in company with Barnabas and John Mark (Acts xiii. 1-3, 5). Landing in Cyprus, the native country of Barnabas, they pass from Salamis to Paphos, where a Jewish sorcerer is rebuked and punished, and the Roman proconsul, Sergius Paulus, is converted (Acts xiii. 5-12). As the name Paul occurs from this point onward in the narrative, the change has been connected with this event, but it is more probable that the apostle had both names. Departing to Perga, on the coast of Asia Minor, John Mark deserts them (Acts xiii. 13). Moving northward to Antioch in Pisidia, the preachers meet with marked success among the Gentiles, and formally announce their mission to the heathen (Acts xiii. 14-52). Passing to Iconium they gain many converts, but arouse great enmity, and flee to Lystra and Derbe. A cripple is miraculously healed in the former city, when the inhabitants attempt to worship the preachers (Acts xiv. 8-18). But opposition follows them; Paul is stoned; the missionaries retrace their steps and return to Antioch (Acts xiv. 19-28).

Dr. Hatch claims that this record must omit many of the labors of the apostle during the eleven years from the first to the third visit to Jerusalem. Probably he did preach in Cilicia and elsewhere, but we have no narrative of these labors. The suggestion that the story of this period is derived from a lost *Acts of Barnabas* is characteristic of the method pursued in the article in the *ENCYCLOPÆDIA BRITANNICA*. Well-authenticated and consistent narratives in our possession are treated as of doubtful authority; but "lost" books are more confidently dealt with.

About A. D. 50 Paul makes a third visit to Jerusalem, of which we have two accounts: one in Acts xv. 4-29, giving the external history, and another by Paul himself (Gal. ii. 1-10), telling of the private conferences. (The literature is given by Dr. Hatch.) Paul was recognized as an apostle of the uncircumcision; it was decided that Christianity was not the religion of a Jewish sect. It would appear from the entire discussion, that Paul claimed to be, not one of the twelve, but an apostle independent of the twelve. Practically the same claim was asserted in the conflict with Peter at Antioch, shortly after (Gal. ii. 11-16), when the latter "drew back and separated himself."

In the second missionary journey Paul was not accompanied by Barnabas, for "a sharp contention" arose between them respecting Mark, a relative ("cousin," Col. iv. 10, R. V.) of the latter. Other causes may have entered. The church at Antioch seems to have been mainly on the side of Paul (Acts xv. 40), and there is no warrant for speaking of the "failure at Antioch," since Paul returned there and remained some time (Acts xviii. 22, 23). The details of this second journey (A. D. 51-4) are given in Acts xvi.-xviii., and few important incidents seem to be omitted from the account. First visiting the disciples in Syria and Cilicia, he proceeds through Phrygia and Galatia, having with him Silas and Timothy (Acts xvi. 1-6). Direct intimations from the Holy Spirit led them to Troas, where a heavenly vision shows them the way to Macedonia (Acts xvi. 6-12). Luke seems to have been of the company from Troas to Philippi, the first European city in which Paul preached. A purple-dealer, named Lydia, was the first convert. Coming into conflict with heathen superstition and covetousness through a miracle of healing, Paul was imprisoned, together with Silas, but miraculously delivered and honorably released as a Roman citizen (Acts xvi. 16-40). At Thessalonica, the next place of labor, success followed, but the Jews raised a mob against the preachers. The enmity of the Jews of Thessa-

lonica drove Paul away from Berea also, and in Athens he came into public contact with philosophic heathenism, delivering in the Areopagus the well-known discourse (Acts xvii.), in regard to which Dr. Hatch raises needless difficulties.

In Corinth, the next city visited, the labors of Paul assumed a more settled character. In this important commercial centre he remained eighteen months. Thence he wrote two letters to the Thessalonians, and despite the obstacles to the gospel he founded an important church in Corinth, in regard to which we learn much from the two letters afterwards written to the Corinthians. In the spring of A. D. 54 Paul left Corinth, touching at Ephesus and Cæsarea on the way to Jerusalem, whence he returned to Antioch, remaining there some time (Acts xviii. 1-23), probably until the close of the year.

The third missionary journey began with a visit to the Christian communities in Galatia and Phrygia (Acts xviii. 23). Paul then came to Ephesus (Acts xix. 1), where he remained for some time. [Dr. Hatch objects to the division into "missionary journeys," intimating that Paul determined about this time "to change the centre of his activity from Corinth to Ephesus." But the narrative in Acts gives no warrant for this assertion.] Some incidents of Paul's life at Ephesus are given in Acts xix., and others may be inferred from the letters written during this journey (Galatians, 1 and 2 Corinthians, and Romans). The first was probably written from Ephesus, though some place it later, at Corinth. The first Epistle to the Corinthians was undoubtedly penned at Ephesus, and the second from Macedonia, during the journey spoken of in Acts xx. 1, 2. The Epistle to the Romans was written from Corinth, where Paul remained three months (Acts xx. 3; comp. Rom. xvi. 1). The record in Acts is very brief at this point, but the personal incidents in the letters are numerous. We see from these the opposition which pursued the apostle, partly from Jewish prejudices (as in Galatia) and partly from factions and immoral usages, etc. (as in Corinth). During this period, beginning in Ephesus, Paul instituted a system of collections for the poor saints in Judæa, as all the accounts indicate. To carry this contribution to Jerusalem he made a fifth visit, which proved to be the last. A plot laid by the Jews at Corinth led him to alter his route, and we find in Acts xx. 3 to xxi. 14 an account of the journey written by an eye-witness. The route was through Philippi, Troas, and Miletus (where Paul met the elders of the Ephesian church); thence to Tyre and Cæsarea.

The apostle arrived in Jerusalem before Pentecost (A. D. 58), when the city was crowded with Jews from all regions. [Dr. Hatch takes pains to cast doubt upon the narrative in the Acts respecting Paul's conduct at Jerusalem, and indeed seeks to prevent "any certain light" emerging from any of the N. T. documents that belong to the later years of Paul's life.] Meeting the elders of the church, it was suggested to Paul, as a matter of prudence, that he appear in the temple with certain Nazirites, thus to prove that he had not taught the Hellenistic Jews to forsake the law of Moses, as had been charged (Acts xxi. 17-25). While carrying out this suggestion, Paul was set upon by some fanatical Jews from Asia (the Roman provinces, of which Ephesus was the capital), who charged him with profaning the temple. Dragging him out of the sacred enclosure, lest his blood might defile it, they attempted to kill him, but he was rescued by Claudius Lysias, the Roman tribune, who appeared with his soldiers. This officer, after giving Paul an opportunity to address the people, and discovering that he was a Roman citizen, sent him to the Sanhedrin, where the Pharisees and Sadducees were divided in opinion respecting him. The discovery of a plot led the tribune to send his prisoner to the procurator Felix at Cæsarea, where he was kept in mild custody for two years, awaiting a trial which never came. The story is told in

Acts xxiv. (Some assign the Epistles to the Colossians, Ephesians, and to Philemon to this period, but all were probably written at Rome.) When a new procurator came in the place of Felix, Paul appealed to the tribunal of the emperor, exercising his right as a Roman citizen. Thus the way was to be opened for fulfilling his desire to preach at Rome (comp. also Acts xxiii. 11). Having made a masterly defence before the new governor (Festus) and Agrippa (Herod Agrippa II.), Paul was sent, with other prisoners, to Rome, in the autumn of A. D. 60. A vivid account of the voyage and shipwreck occurs in Acts xxvii., xxviii. [It is impossible to avoid noticing the doubts cast upon this account by Dr. Hatch in the *ENCYCLOPÆDIA BRITANNICA*. If these chapters cannot be trusted, then no record of antiquity can be termed historical.]

Rome was reached in the spring of the following year. Here two years were spent in mild imprisonment, which did not prevent the apostle from active labor. He preached to the soldiers, wrote four of his Epistles (Colossians, Ephesians, and Philemon; these three about the same time, and, probably afterwards, Philippians).

The Acts of the Apostles tells us nothing more. This is strange, if Paul was beheaded at the close of this imprisonment. Furthermore, the pastoral epistles cannot well be placed at any point before this. Accordingly it seems safe to accept as fact the statement of some early Fathers that Paul was released, and then, after a second imprisonment at Rome, beheaded at some time between A. D. 66 and 68. (For details of these later years, see *PASTORAL EPISTLES*.)

2. *The Chronology of Paul's Life*.—Two dates can be fixed with reasonable certainty: (1) The death of Herod Agrippa I. took place in A. D. 44, and the second visit to Jerusalem occurred about the same time (Acts xi. 30 and xii.). (2) The governorship of Festus began in A. D. 60, and the voyage to Rome occurred shortly after. Starting from these dates we can approximately determine the time of the leading events of the apostle's life; but the Jewish mode of counting parts of years as full years prevents accuracy, and has led to the great variety in the chronological tables. In some cases there are incidental reasons tending to confirm the assigned dates.

	A. D.
Date of conversion.....	37
First visit to Jerusalem.....	40
Second visit to Jerusalem.....	44
First missionary journey.....	45
Third visit to Jerusalem (council).....	50
Second missionary journey.....	51-54
Fourth visit to Jerusalem.....	54
Third missionary journey.....	54-58
Last visit to Jerusalem (spring).....	58
Imprisonment at Cæsarea.....	58-60
Voyage to Rome.....	60-61
First imprisonment at Rome.....	61-63
[Release.....	63
[Reimprisonment and martyrdom.....	66 or 68

There are various theories which would modify the above list of dates, but it presents a working theory and preserves the events in their relations, so far as recorded. (See Schaff, and many others.)

3. *The Writings of Paul*.—The epistles may be divided into three groups, according to the time of composition: (1) The *earlier epistles*, 1 and 2 Thessalonians (A. D. 53), Galatians, 1 and 2 Corinthians, and Romans (57 and 58). Some place Galatians immediately before Romans. (2) The *epistles of the captivity*: Colossians, Ephesians, Philemon, and Philippians (A. D. 61-63). Some place Philippians first in this group. (3) The *pastoral epistles*, written after the first Roman imprisonment. In connection with the last group there is the uncertainty, to which reference has already been made, respecting the closing events in the life of Paul. The Epistle to the Hebrews is anonymous, and the question of authorship has been

discussed in the article on that epistle. (See **HEBREWS, EPISTLE TO THE**.)

These writings are all of them letters, not merely theological or didactic treatises. Most of them have a definite occasion, and each a distinct purpose. They are human to the last degree, yet nowhere do we find more marked evidence of Divine inspiration, which the apostle vehemently claims for the gospel he preached (Gal. i. 8-11). A brief characterization of these writings, according to their contents, is given here: Romans, on salvation by faith for all who believe; 1 and 2 Corinthians, personal, in view of the divisions and sins at Corinth. [The view that another letter to the Corinthians was written, and has been lost, is not improbable in itself; but the passages in 2 Corinthians (ii. 3, 4; vii. 8-12) which seem to point to such a letter are by no means conclusive. If there was such a letter, it probably contained only matter affecting the local church in its then condition.] Galatians, in defence of his apostleship and doctrine (against Judaizing teachers); Ephesians, of the church in Christ; Philippians, a personal and affectionate letter; Colossians, on Christ the head of all things (with a rebuke of certain errors); 1 and 2 Thessalonians, to correct certain errors about the coming of Christ; 1 and 2 Timothy and Titus, for the guidance of these Christian teachers; Philemon, a personal letter, sent by Onesimus who was returning to his former master. (See **ROMANS, EPISTLE TO THE**.)

The Pauline theology can only be learned from these epistles. An effort has been made to find in them glaring inconsistencies; now to deny the genuineness of one or the other, and again to emasculate Christianity by denying the possibility of logically formulating the views of its earliest teachers. A persistent attempt to prove the apostle out of harmony with the teachings of the other apostles has been successfully met by recent Christian apologists. We may remark (1) The meaning of the terms used by Paul can be as accurately determined as in the case of any ancient writer. (2) The obscurity arises from the greatness of the thoughts. (3) The leading positions taken by him are obvious to all who interpret by the historico-exegetical method. (4) The difficulties that have arisen are largely due either to the mystical (allegorizing) method of interpretation, or to the influence of ecclesiastical dogmatism, or to both. (5) The teachings of Paul all assume a practical character, from his burning conviction that salvation in Christ was designed and adapted for all classes, Jew and Gentile alike. Hence he emphasizes the free grace of God, justification by faith, new life in the spirit over against the old life in the flesh; all these in such a way as to make it appear that Jew and Gentile alike can share in these privileges, and need to share in them. Dr. Hatch, in the **BRITANNICA** article, fails to do justice to Paul's use of the term "flesh." It means in the ethical sense, human nature as it is by birth, estranged from God, before regeneration by the Holy Spirit. (See **ROMANS, EPISTLE TO THE**.) (6) Out of this grows the culminating thought of the Apostle Paul's theology—Jew and Gentile united in one body in Christ (Eph. i.-iii.).

Assuming that these epistles (or any number of them) are genuine, we have in them the strongest contemporary evidence to the facts respecting Jesus Christ that are recorded in the Gospels. It is a characteristic of modern apologetics that it starts with the four undoubted epistles of Paul (Galatians, 1 and 2 Corinthians, and Romans), and shows from these writings that in A. D. 58 an immense number of people believed in Jesus Christ, and that Paul preached a Saviour, who had been crucified and raised again from the dead. The main facts he presents as facts, and it was the power of this historical Person that had transformed him. Modern skeptical criticism is simply an unavailing effort to escape the legitimate inference from these acknowledged facts respecting Paul and the gospel he preached. Either he was an impostor or a de-

luded fanatic, or the gospel facts are facts, and his explanation of them a Divine revelation.

4. *The Character of the Apostle Paul.*—Before his conversion Paul led a blameless life, according to the conceptions of Jewish morality (Phil. iii. 4-6). The description of the life under the law portrayed in Rom. vii. 7-13 is probably applicable to his religious condition as a conscientious Jew. It may have been his fierce striving to quiet an awakened conscience that made him a persecutor. Immoral, in the ordinary sense, he certainly was not, though he speaks of himself as "the chief of sinners" (1 Tim. i. 15). The same man became a Christian, and the same characteristics pervaded his after life, which now had new motives and aims. The persecutor of the Nazarenes became the Apostle to the Gentiles. What his physical infirmity was cannot be certainly determined. His personal appearance seems to have been far from prepossessing. But of his zeal, his intellectual power, his acuteness of thought, his decision of character there can be no question. It is too frequently imagined that he did not win affection from men. The greatness of his intellect and the tremendous results of his didactic statements have led many to forget how greatly beloved he was by his companions. Some contrast him with the Apostle John, regarding the latter as affectionate even to weak amiability, and implying that Paul was harsh and forbidding. But all the records prove him to be a man who won the personal affection of those associated with him. His practical wisdom is often obscured by those who would deem him the great "dogmatist." Yet the whole story of his life is full of instances of his tact, his wise dealing with men and with difficult questions. Add to this the indications we have of a widespread system of missionary labor, directed by him even when in prison; and it will appear that few men in history were so symmetrical in greatness: great in intellect, great in affection, great in will. But in the presence of his Master he calls himself "less than the least of all saints."

How such a life and character as his can be accounted for he himself tells us. No other satisfactory explanation of the phenomena has ever been suggested. Whenever the statements he emphasizes have been adequately recognized by men, similar characters have been formed, and under no other influences.

(M. B. R.)

PAULDING, HIRAM (1797-1878), rear-admiral U. S. N., was born in Westchester co., N. Y., Dec. 11, 1797. His father, **JOHN PAULDING** (1758-1818), was one of the captors of Major André, and was himself thrice taken prisoner in the Revolutionary war. For the capture of André, Paulding and his two companions received from Congress a silver medal and annuities of \$200. A monument to his memory was erected at Peekskill in 1827 by the city of New York. Hiram entered the U. S. Navy in 1811 as midshipman and served in McDonough's fleet on Lake Champlain. He was made lieutenant in 1816 and accompanied Capt. Porter in his expedition against the West Indian pirates in 1823. Rising to the rank of captain in 1844 he cruised with the Vincennes three years in tropical waters. In 1857 while commanding the Home squadron he broke up Walker's expedition against Nicaragua and brought the filibusters to the United States. The State of Nicaragua in 1860 acknowledged his service by the gift of a sword, Congress not allowing him to accept more. Paulding was made rear admiral on the retired list in December, 1861, but as commander of the New York navy-yard he rendered important service in preparing vessels for various employment during the civil war. He also assisted in protecting public property during the draft riots of New York city in 1863. After the war Paulding was for a time governor of the Naval Asylum in Philadelphia. He died at Huntington, L. I., Oct. 20, 1878, being then the senior officer on the retired list.

PAUPERISM. See **CHARITY ORGANIZATION.**

PAWNBROKING is the lending of money for a certain rate of interest on the security of goods, such as jewelry, apparel, utensils, or tools, deposited with the lender. Practically it has existed since a remote antiquity, but it became a recognized business in Europe during the Middle Ages. The merchants of Lombardy who established themselves in the principal cities of England and the Continent were in the habit of lending money on pledges of jewels and costly articles. In course of time the business passed to other hands, but the pawnbroker's familiar sign of the three gilt balls is traced to the coat of arms of the Medici family, who were the most enterprising of the Lombardy merchants. Their business was with kings, nobles, and wealthy merchants, but as its advantages became known, efforts were made to extend such benefits to other classes. Soon the poor, too ignorant to understand, too weak to maintain their rights, were grossly oppressed by the usurers. Christian charity came to their relief and established in Italy in the latter part of the fifteenth century the *monte di pietà*. In the course of the next century such institutions were found in France, under the name *mont de piété*. These were at first charitable institutions, which charged only a rate sufficient to cover the necessary expenses. In Italy they have maintained this character until the present time. In France and other European countries they have been under the control of the government since the middle of the eighteenth century. Their transactions are strictly regulated by law and administered by public agents. In Paris there is one principal establishment and three auxiliary offices. There are also authorized commissioners stationed in different parts of the city, but whose transactions do not bind the administration until ratified at the central office. Here there is a board of appraisers; and the loan is limited to two-thirds of their valuation of the article, except in case of articles of gold or silver, when four-fifths may be advanced. The least sum lent is three francs, but there is no upper limit to the demand. The commissioners, who carry on four-fifths of the business, receive 2 per cent. for each pledge effected and 1 per cent. for each redemption. The rate of interest is 9 per cent. per annum, but the first month's instalment must be paid in advance, and the rest fortnightly. The loan is for a year, and if the article is not then redeemed it is sold within a month at public sale; in some cases the loan may be renewed for another year. Sometimes too the pawnner is allowed to demand the sale of his pawn before the expiration of a year. For the maintenance of the business certain revenues from other sources may be drawn upon, yet there is generally a small balance in favor of the administration.

In England pawnbroking is conducted in private establishments which are regulated by law. Attempts at establishing *monts de piété* have never succeeded. In the United States the business is regulated by the law of the several States. Usually the mayor of a city has the sole power of issuing a license to a pawnbroker, who is required to be a person of good repute. In New York the rate is limited to 25 per cent. per annum, on sums less than \$25, and to 7 per cent. on sums beyond that amount. Yet the rate usually charged is 3 per cent. a month and there are further charges for storage, safe-keeping, etc., which materially reduce the sum received by the pawnner. The unredeemed pledges are required to be sold at public auction, and the law also declares that the amount received for any article over the pawnbroker's just claims shall be returned to the depositor. The shops are generally found in the business streets of the poorer districts of the cities, and are more used by the foreign population than by the native-born. The keepers as a rule avoid receiving stolen goods, but there are persons, known as "fences," who make a business of receiving and disposing of stolen property, and for this purpose profess to keep a pawn-shop. (J. P. L.)

PAWNEES, a tribe of American Indians, who

originally resided chiefly in Nebraska, but extended into Kansas and Texas. They were noted on Marquette's map in 1673. From them the Arickarees (*q. v.*) separated and wandered northward. Some tribes formerly existing in Louisiana are also thought to belong to the same family. The Pawnees (or Pani) proper were bold hunters, excellent horsemen, and fierce warriors. They carried on constant war with the Sioux, Tetans, Arapahoes, Sacs and Foxes, and other tribes. They frequently offered human sacrifices to the sun, and this practice was continued in the present century. They lived in lodges covered with earth, and the women cultivated some grain, but the men hunted the buffalo. When the Delawares were removed to the land south of the Platte they came in collision with the Pawnees, and in 1832 burnt the Great Pawnee village on Republican Fork. By treaty with the United States in 1833 the Pawnees gave up their claim to land south of the Platte, received aid, and for a time made notable progress in civilization, but this excited the envy of their hereditary enemies, the Sioux, who finally drove them from their villages. The U. S. Government having withdrawn aid and protection, the tribe was soon reduced to half its original number. In 1861 they furnished many scouts to the Union army and took part in the campaign in Minnesota against the Sioux. The latter, after being reduced to peace, sought revenge on the hapless Pawnees, who were compelled to sell their lands and emigrate to a reservation in the Indian Territory. The total amount of this land is 283,020 acres (100,000 tillable), and when the entire tribe was finally removed to it in 1876 they numbered 2026. Part of the land, 53,000 acres, was purchased from the Creeks by the U. S. Government with the proceeds of the sale of Pawnee lands in Nebraska, but the title has not yet been transferred to the Pawnees. The other part was ceded by the Cherokees to the U. S. Government in trust for the Pawnees. Under Pres. Grant's administration the missionary work among the Pawnees was assigned to the Society of Friends. They are peaceable and well disposed, but have steadily diminished in number, until in 1887 they were reported as only 918, of whom 800 wore citizen's dress. They cultivated 2094 acres and had 2597 under fence. They cultivated wheat, corn, melons, and vegetables. They had 1400 horses, 575 cattle, 200 swine.

PAWTUCKET, a city of Rhode Island, in Providence co., is on Pawtucket River at its falls, 4 miles N. of Providence, and 40 miles from Boston, and on the Boston and Providence, the Providence and Worcester, Old Colony, New York and New England, and the Moshassuck Valley Railroads. It has 4 hotels, 3 national banks, 3 savings banks, 1 daily and 2 weekly newspapers, 25 churches, numerous schools, including a high-school, and a public library. The falls give abundant water-power, which is largely utilized in cotton-, woollen-, hair-cloth-, thread-, and other mills, the total establishments being nearly one hundred. Here Samuel Slater first introduced cotton-manufacturing into the United States. Pawtucket is lighted with gas and electricity, and has excellent water-works and a paid fire-department. Its property is valued at \$20,000,000; the public debt is \$1,100,000, chiefly due to the water-works; the yearly expenses are about \$250,000. Pawtucket was settled about 1640, and belonged to Massachusetts until 1862. It was incorporated as a town in 1874, and as a city in 1886. The population of the township in 1880 was 19,630.

PAYER, JULIUS, BARON, an Austrian explorer, was born at Schönau, Sept. 1, 1842. He was educated at the Military Academy in Vienna, and entered the service as lieutenant in 1859. For a time he was professor of history in the Academy and again was engaged in scientific work in the Austrian Alps. In 1869 he took part in the Polar expedition under Capt. Koldewey, which explored the east coast of Greenland and penetrated into the interior. Returning to Bremen

in September, 1870, he joined Weyprecht in preparations for a new expedition, which were enthusiastically supported by the whole empire. The steamer Tegethoff started in July, 1872, passed the winter at Nova Zembla, and then drifted northward, enclosed in ice. In October Payer discovered the land, which eventually proved to be as large as Spitzbergen, and named it Franz Josef in honor of the emperor. For details of his explorations see ARCTIC EXPLORATION. The farthest point reached was 82° 5' N. lat. After his return to Austria Payer was made Baron and soon resigned his commission in the army. He then settled at Frankfort, but afterwards removed to Munich, where he became a painter. As his first work in this line he exhibited in 1884 *The End of the Franklin Expedition*. Besides several geographical monographs he published a full account of his expedition (Vienna, 1876).

PAYNE, JOHN HOWARD (1792-1852), the author of "Home, Sweet Home," was born in New York, June 9, 1792. He early showed a fondness for the stage, though his father, a noted schoolmaster, entirely disapproved his inclination. At the age of thirteen, while employed in a counting-house, he published a weekly paper called *The Thespian Mirror*. Its merits being recognized a friend sent him as a student to Union College, and in February, 1809, made his first appearance as an actor in the Park Theatre, New York, in the character of "Young Norval." After visiting other American cities he appeared at Drury Lane Theatre, London, in June, 1813. For nearly twenty years he remained in England, being engaged as actor, manager, and playwright. Besides translating and adapting French plays he produced *Brutus* (1818), in which Edmund Kean took the title-role, and *Charles the Second*, which became a favorite with Charles Kemble. Another of his plays was *Thérèse, or the Orphan of Geneva*. His English opera, *Clari, the Maid of Milan*, contains the song which has become dear to all English-speaking people. In August, 1832, Payne returned to New York and engaged in minor literary and dramatic work. In 1841 he was appointed U. S. Consul at Tunis, but was recalled four years later. In 1851 he received the same appointment and went again to Tunis, where he died April 10, 1852. His grave in the British cemetery there was marked by a stone erected by one of his successors in office, but afterwards fell into neglect. Mr. W. W. Corcoran of Washington in 1883 caused his remains to be removed and brought to that city, where a suitable monument has been erected in Oak Hill Cemetery. See C. H. Brainard's *John Howard Payne* (1885).

PAYSON, EDWARD (1783-1837), a clergyman, was born at Rindge, N. H., July 25, 1783, being the son of Rev. Dr. S. Payson (1758-1820) and nephew of Rev. Dr. Phillips Payson (1736-1801). Edward graduated at Harvard College in 1803, spent three years in teaching at Portland, Maine, and was ordained to the ministry in 1807. He was the colleague of Rev. M. Kellogg until 1811, and thenceforward sole pastor. He was especially noted for his fervent piety and deeply religious character. He died Oct. 22, 1837. His *Sermons* were published in 3 volumes (1846), with a biography.

PAZ-SOLDAN, PEDRO, a Peruvian poet, was born at Lima, in May, 1839. He was brought up on his father's estate of Arona, from which he has taken his pseudonym, "Juan de Arona." In 1859 he went to Europe, and pursued literary studies at Madrid, Paris, and Rome. Before he returned, in 1863, he had published his first collection of poems, *Ruinas* (Paris, 1863). These were of very unequal merit, and reflected the various experiences by which he had been influenced. He served in various government offices in Lima, and was sometimes sent abroad in a diplomatic capacity. To the Peruvian journals he contributed numerous sketches of travels and manners, and several translations. His *Poesías Peruanas* (Lima, 1867) gives

graphic pictures of the people and scenery of his native land. *Chispazos* is a little volume of sonnets and epigrams. Paz-Soldan has been elected a corresponding member of the Madrid Academy, and has published a *Diccionario de Peruanismos*, illustrating the variations of Peruvian speech from pure Castilian.

PEA. A leguminous garden plant, of the genus *Pisum*. The common pea, *Pisum sativum*, is a smooth and glaucous annual, of from 6 inches to 6 feet high, according to the variety, with pinnate leaves, usually having two pairs of leaflets, the petiole terminating in a branching tendril, of use in the climbing habit of the plant. The flowers are white or purplish-violet in color, of the irregular form known as papilionaceous. The ovary is one-celled, the pod somewhat fleshy, containing several globose seeds, with very thick cotyledons. The native country of the pea, as in the case of many of our garden vegetables, is unknown. It was cultivated by the Greeks and Romans, but there is no proof that it was known earlier. It is now almost universally cultivated, and is everywhere a favorite esculent. The highest degree of perfection of the pea is attained under comparatively low temperatures, and the early spring sowings always produce the best results. It needs warm, light soils, moderately manured for early maturing, though for abundant crops a strong loam inclining to clay is best. For early crops it is sown in November, or at the first opening of the soil in February or March. The pea is ordinarily eaten in its green state, and "cannot be eaten too young, or too soon after gathering," as it rapidly deteriorates in healthfulness if kept too long. From this fact peas brought from a distance are apt to be flavorless and unwholesome.

The *P. arvense*, or field-pea, is probably derived from the same original species as the garden-pea. It is valuable not only for its seed but as a forage-plant, for which some varieties are specially adapted. There are perhaps more varieties of the pea than of any other garden vegetable, the varieties dividing into two very distinct classes: the common pea, of which only the unripe seeds are eaten, and the eatable podded, called the sugar-, skinless-, or string-pea, in which the pods are succulent, and are used in the same way as string-beans. This class is not much cultivated. Of the common pea there are two distinct kinds, some being smooth and yellowish-white when ripe, others wrinkled and greenish, and much larger. Ripe peas contain much nutriment, and in a dried state are largely exported from this country to England, where they are much more extensively used than here.

The pea is liable to a variety of enemies, of which the most distinctive are the mildew, which often produces serious injury, and the pea-weevil, a small beetle. (See AGRICULTURE, Chap. IX.) Many other varieties of pulse are called peas, as the chick-pea and the cow-pea (*Dolichos*) of the South, a valuable forage-plant, of great importance in Southern agriculture. Its seeds resemble those of the bean. The production of peas in America in 1880 was 6,514,977 bushels. (C. M.)

PEABODY, ANDREW PRESTON, educator and author, was born in Beverly, Mass., March 19, 1811. He graduated at Harvard College in 1826, studied theology, and became tutor in the college in 1832. In the next year he was ordained pastor of the South Congregational Church, Portsmouth, N. H. In 1860 he became preacher and Plummer-professor of Christian morals in Harvard College, and held this position until 1881. Throughout his career he was a diligent writer, and his published sermons, lectures, and pamphlets are numerous. For several years he was one of the editors of the *Christian Register*, and from 1852 to 1861 he edited the *North American Review*, discussing with ability and in animated style the social and educational questions of the time. Among his works are *Lectures on Christian Doctrine* (1844); *Sermons of*

Consolation (1847); *Christianity the Religion of Nature* (1864); *Reminiscences of European Travel* (1868); *Moral Philosophy* (1873); *Christianity and Science* (1874); *Christian Belief and Life* (1875); *Conversation* (1882); *Baccalaureate Sermons* (1885). He published also translations of Cicero's philosophical treatises and a volume of *Reminiscences* (1888).

PEABODY, ELIZABETH PALMER, whose life has been devoted to the cause of education, was born at Billerica, Mass., May 17, 1812. Her father was a physician, and her sister was married to Nathaniel Hawthorne (for whom see ENCYCLOPÆDIA BRITANNICA). Miss Peabody spent her early life in Salem, but has resided chiefly in Boston. She assisted Mr. Bronson Alcott in his school, of which she has preserved an account in *Records of a School* (1833), a book revived in recent years. She was drawn also into the transcendental movement, and contributed to the *Dial*. Besides preparing various text-books she edited *Aesthetic Papers* (1849), and published *Crimes of the House of Austria* (1852), *Lectures on the Nursery and Kindergarten* (1874), and *Reminiscences of W. E. Channing* (1880). She was associated with Mrs. Horace Mann in writing *Moral Culture of Infancy* (1863), and translated into English De Gerando's *Self-Education* (1860). She has been one of the most vigorous advocates of the kindergarten system, and for several years she conducted a magazine in its behalf.

PEABODY, WILLIAM BOURN OLIVER (1799-1847), an American clergyman and author, was born at Exeter, N. H., July 9, 1799. He graduated at Harvard College in 1816, studied theology under Rev. Dr. Henry Ware, and was ordained, in 1820, pastor of the Unitarian Church at Springfield, Mass. He prepared for Sparks' *American Biography the Lives of Alexander Wilson, Cotton Mather, David Brainerd, and James Oglethorpe*. Having a fondness for natural history he frequently lectured on such subjects, and prepared for the State of Massachusetts a *Report on the Birds of the Commonwealth* (1839). He died at Springfield, May 28, 1847.

His twin-brother, OLIVER WILLIAM BOURN PEABODY, after graduating at Harvard, became a lawyer at Exeter, but removed to Boston in 1830, and was for several years an editor of the *Daily Advertiser*. After spending a year at Jefferson College, La., as professor of English literature, he became a Unitarian preacher in 1845. He undertook to publish his brother's literary remains, but before completing the task died at Burlington, Vt., July 5, 1848. He wrote for Sparks' *American Biography the Lives of Gens. Putnam and Sullivan*. His son, EVERETT PEABODY (1831-1862), who was killed at the battle of Shiloh, edited the works of both his father and uncle.

PEACH. The widely cultivated tree yielding this favorite fruit is a member of the See Vol. XVIII. *Rosaceæ*, or rose family. It was formerly called *Persica vulgaris*, but through its close affinities to the almond it afterwards received the name of *Amygdalus Persica*. More recently the peach, almond, apricot, plum, and cherry have been classed into one genus known as *Prunus*. It is now believed, indeed, that the peach, almond, and nectarine are identical in origin, the almond being the original form, the peach an improved or fleshy almond, and the nectarine a persistent sport of the peach. It was long believed that the peach originated in Persia, but De Candolle is of the opinion that it probably first appeared in China, and gradually migrated westward.

The peach is a tree of medium size, usually not over fifteen or twenty feet in height and rarely reaching thirty. It is regarded as short-lived, yet under proper conditions has been known to live for more than a century. It has a spreading head, with deep green leaves, long, narrowly lanceolate, and serrate. The flowers appear before the leaves and are of the

general structure of this section of the rose family. The calyx has a short, bell-shaped tube, with five spreading petals, usually of a rosy hue, the stamens numerous, pistil solitary, ovary containing two ovules, only one of which usually develops. The fruit is a drupe, or stone fruit, the outer portion becoming fleshy and when ripe very soft and succulent. The stone is a hard, nut-like body. The peaches are divided into two sections, known as clingstones and free-stones, in the first of which the flesh clings firmly to the stone, while in the second it readily separates and leaves the stone clean and dry.

The peach is readily injured by frosts and cannot be cultivated with profit in high latitudes. In middle and northern Europe it is raised against walls and in hothouses, but is produced as a standard tree only in the south. In the United States it cannot be raised profitably much beyond 40° north latitude. It was introduced into North America by the early European settlers, probably about 1700, and is now very extensively cultivated. This country, indeed, is the only one in which it is within the reach of the poorer classes, it being in Europe a luxury of the rich.

The peach reaches its highest perfection in the Middle States, its flavor not being so delicate when raised farther north, while in the South it is apt to grow greatly to foliage and wood, though with care fine large fruit may be produced. The peach area of the Middle States includes portions of New Jersey, Delaware, Maryland, and Pennsylvania, though Delaware



Peach-Gathering in Delaware.

and the Chesapeake counties of Maryland and Virginia are the most important sections of this region. Peaches are here produced in great abundance and of unsurpassed quality. The 1888 crop is estimated variously at from 6,000,000 to 10,000,000 baskets, an unprecedented yield. Formerly the large crops of this region were in considerable part wasted for want of a market, but an extension of the area of distribution and a great development of the processes of drying and canning have overcome this difficulty, and the largest crops can now be profitably disposed of.

Farther south in the Atlantic States the peach is raised only sufficiently to supply local needs, but the State of Georgia has a very large area devoted to peach orchards and produces some very fine fruit. The peach here ripens early and is safe from danger of frost. Some of the orchards contain 70,000 trees. Florida has also made peach-raising one of her industries. In the States of the Mississippi Valley the peach is largely cultivated. Texas is the first in the market, having ripe peaches by the first of June. Ohio, Illinois, and Missouri produce largely, while the lake shore of Michigan yields peaches abundantly, the temperature being modified by the presence of large bodies of water. In California immense crops of peaches are raised, and the cultivation is steadily increasing. The fruit there is said to be of excellent quality.

Many varieties of the peach are cultivated, and the season in the Middle States continues from late July to early October. It grows well in sandy, rather poor

soils, but the most abundant crops are obtained from land of moderate fertility. It will also prosper on clayey and calcareous soils, but too high manuring is injurious to the fruit. It bears early, sometimes in the second year after planting, but as a rule the orchard peach is short-lived. The tree has many enemies, the most destructive being a borer (*Ageria exitiosa*), which is difficult to handle. (See "Peach-tree Borer" under AGRICULTURE, Chap. IX.) The tree is also subject to a disease known as the "yellows," which attacks the leaves. These natural enemies in connection with the fact that the blossoms are very liable to injury by late frosts, render the peach-crop a very precarious one, yet it is sufficiently lucrative to overcome these disadvantages. (C. M.)

PEALE, CHARLES WILSON, (1741-1827), painter, was born at Chestertown, Md., April 17, 1741. After the death of his father, Rev. Charles Peale, in 1750, the family removed to Annapolis. Here Charles was apprenticed to a saddler and followed that trade for some years. But being attracted to portrait-painting, he obtained some instruction from Hesselius and afterward from Copley at Boston in 1768. Thence he went to London, studied painting under Benjamin West, and learned also engraving, miniature-painting, and wax-modelling. Returning to Maryland he executed many portraits, among them one of Washington in the uniform of a Virginia colonel. In 1776 he went to Philadelphia and as captain of volunteers fought at Trenton and Germantown. In 1779 he was elected to the Pennsylvania Legislature. For fifteen years he was the only portrait-painter of note in North America. His portraits of the prominent revolutionary officers were the chief attraction in the picture-gallery which he afterwards formed. This was indeed but an adjunct to a museum of natural history, which he opened at Philadelphia in 1802, being incited thereto by the discovery of a fossil mammoth in Ulster co., N. Y. After various ineffectual efforts, from 1791 on, he assisted in founding the Pennsylvania Academy of Fine Arts, to whose exhibitions he contributed for seventeen years. He was noted for his mechanical ingenuity and was the first American to manufacture artificial teeth. He published some essays on bridges, health, and other topics. He painted fourteen portraits of Washington, the last in 1793. His last work, now in the Philadelphia Academy, was a full-length portrait of himself at the age of 83. He died at Philadelphia, Feb. 22, 1827. He had been thrice married.

His son, REMBRANDT PEALE (1778-1860), also a painter, was born in Bucks co., Pa., Feb. 22, 1778, and was trained by his father. He painted a portrait of Washington in 1795, and practised his art in Charleston, S. C. In 1801 he went to Europe, studied under West in London, and while in Paris painted many portraits of distinguished persons for his father's museum. After his return in 1809 he was busily engaged as a portrait-painter. He also executed the large pictures of The Roman Daughter and The Court of Death, which were exhibited in several cities. He published a *Biography of his father*; *Notes on Italy* (1831); *Portfolio of an Artist* (1839); *Reminiscences of Art and Artists*. In 1859 he lectured in several cities on the portraits of Washington. He died at Philadelphia, Oct. 3, 1860. Peale's Museum, which from an extensive addition of Chinese curiosities came to be called the Chinese Museum, was destroyed by fire in 1851. Several other members of the Peale family devoted themselves to art.

PEANUT, *Arachis hypogaea*, the pea, ground, or earth nut, is a herbaceous annual, of the pulse family, of the natural order *Leguminosae*. It has a branching stem nine to eighteen inches high, with hairy pinnate leaves, having four broad, blunt leaflets in pairs. The flowers are papilionaceous, of yellow color, and produced singly in the axils of the leaves. This plant has the peculiar habit, after the decay of the petals of

the lower blossoms which alone bear fruit, of bending downward the flower-stalk and insinuating the ovary into the earth to the depth of several inches. Here the fruit develops and ripens. The seeds are borne in an oblong pod 1 to 1½ inch long, contracted in the middle, and with a reticulated surface of yellowish color. It contains ordinarily two seeds, of irregular ovoid form, with thick cotyledons and a straight radicle.

This plant is a native of Africa or South America. It was not known till the discovery of America, but seems equally prolific in both countries. It is now



Peanuts.

cultivated throughout the tropics and to a considerable extent in the temperate regions of North America, its large, sweet, pleasant-tasted seeds being widely used as food. It succeeds best in a warm, light, loamy soil, deeply plowed and well pulverized, and yields a quick and abundant return, fifty bushels per acre being produced in good, well-cultivated soil. It is generally grown in Brazil, the West Indies, India, and parts of Africa, and in several of the Atlantic States of America, its tropical character hindering its successful culture in the Northern and Middle States. The plant is killed by the first frost, the nuts then maturing. The peanut was formerly largely imported into the United States, but a sufficient supply is now yielded by Virginia and the Carolinas. The use of the seeds as food is very considerable, New York city alone absorbing more than half a million bushels annually. They are very nutritious and form an important addition to the food-supply of the world.

The seeds contain much oil, yielding under pressure over 20 per cent. of a fixed, non-drying oil, which is said to be in no way inferior to olive oil for table use. It is used principally as a lubricant and in soap manufacture, and to some extent in woolen-factories for cloth-dressing. In lamps it is better than sperm oil, but thickens in cold weather. (See OILS.) In addition to these uses the peanut is also a good fodder-plant. The vines and leaves somewhat resemble clover. When ripe the vines are pulled from the ground, the nuts adhering tenaciously and requiring to be removed by hand. (C. M.)

PEAR, *Pyrus communis*, is a near relative botanically of the apple, and the fruit, while quite distinct in sensible qualities, is closely similar to the apple in botanical characters. The flowers are of the type of the *Rosaceae*, to which family the pear belongs, and are pure white in color, with purple anthers. The fruit

generally tapers towards the stem, the base of which is not sunk in a cavity, as in the apple. The tree is ordinarily about 20 feet high, but has been known to grow as high as 60 feet. By a dwarfing process of grafting much smaller trees, known as dwarf pears, are produced. The wood is very hard and close-grained, and, dyed black, has been used as a substitute for ebony. The fruit has not the firmness of the apple, but is sugary and melting, with hard concretions near the core composed of indurated cells.

The pear is a native of temperate Europe and the Caucasus, and was cultivated at an early date, many varieties being known in Pliny's time. At the present day more than 3000 varieties are enumerated in the catalogues, though of course very few of these are in practical cultivation. It is a long-lived tree, one specimen in England being about 400 years old. One in New York planted by Peter Stuyvesant in 1648 was still bearing fruit 200 years afterward. It is cultivated as a standard tree, by grafting on pear seedlings, and as a dwarf, by using the thorn, mountain ash, or quince as a stock for grafting. The quince is generally used.

The pear needs a strong, dry soil, and is subject to many insect enemies, which attack the leaves and bark. Its worst foe, however, is the "blight," which is probably produced by a minute fungus, which rapidly spreads and is destructive to branch and tree alike if not quickly eradicated.

Of pears grown for sale only a few of the many varieties are widely cultivated. A general favorite among these is the Bartlett, which is notable for its size, lusciousness, and abundant bearing. It is estimated that 90 per cent. of the pears grown for profit in the United States are of this variety. Another favorite is the Seckel, a small fruit, but of unsurpassed flavor. This is traced to a single tree in the suburbs of Philadelphia. As a rule pears are better if picked when just mature and ripened in the house. Many varieties which are excellent thus ripened are worthless if left to ripen on the tree.

The pear has a wide range of distribution. Unlike the apple and the peach, it flourishes in the sea-coast country of the South Atlantic, while it is equally at home in the highlands of the interior. The three States in which it is most largely produced are Georgia, Florida, and California. The latter seems particularly adapted to its culture, and produces it in vast quantities and of extraordinary size. Very many of these pears are shipped to the East, while great quantities are preserved by canning, a process to which the pear lends itself excellently, retaining much of its original flavor. (C. M.)

PEAT is found in the United States towards the northern border from New England to Dakota, but more extensively in Canada and Newfoundland. It consists of partially decomposed vegetation, and forms only in cold, moist climates. As fuel it has never attained any prominence in America, though it is so used throughout Northern Europe, where several varieties, distinguished partly by color, are known. The best is the dark-brown or black, which is the most free from earthy matter. This mineral matter varies greatly; some peats, when burnt, leave chiefly carbonate of lime, others the sulphate, while silica, phosphates, etc., also occur.

PECAN, *Carya olivæformis*, is a tree belonging to the walnut family (*Juglandaceæ*) and to the hickory genus, of the several species of which it produces the most palatable fruit. It is a handsome, lofty, North American tree, growing to a height of 70 feet, with a slender, straight trunk, and compound leaves with petioles 12 to 18 inches long, with 13 to 15 sessile leaflets. It is found on river banks from Illinois southward to Mississippi, and will bear in gardens and sheltered places as far north as the banks of the Hudson. It was introduced into France many years ago. The pecan is the most rapidly growing of the hickories, and yields a coarse-grained but heavy and durable

wood, which is stronger and more elastic than the white ash. Its bark, as in all the hickories, contains yellow dye principles, from which an olive dye may be made by the addition of copperas, and a green by the addition of alum.

The pecan tree is particularly esteemed for its fruit, which is the most delicious of all the hickory nuts. It is sweet and of an agreeable flavor, and has a thin, easily broken, yellowish-brown shell, without the internal partitions of the ordinary hickory nut. The pecan is raised extensively for commercial purposes in the Southern States, Texas alone exporting annually over \$50,000 worth of its nuts.

PECK, WILLIAM DANDRIDGE (1763-1822), entomologist, was born in Boston, graduated at Harvard College in 1782, and became professor of natural history there in 1805. He published a catalogue of *American and Foreign Plants* in 1818. For his other work see AGRICULTURE, Chap. IX. at end.

PEDRO II., DE ALCANTARA, DOM, Emperor of Brazil, was born at Rio de Janeiro, Dec. 2, 1825. He was the son of Dom Pedro I. and of Leopoldina, arch-duchess of Austria. His father had renounced the throne of Portugal in 1826 in favor of his infant daughter, Donna Maria de Gloria, and in 1831, weary of the struggle with the revolutionary tendency of the Brazilians, abdicated in favor of his son, then five years old. He had appointed Andrada e Silva, the exiled chief of the democratic party, tutor of the child. The tutor accepted the position in good faith, but two years later was driven from the palace by a mob. A council of regency then administered the government until July, 1840, when Pedro II. was declared of age, though not yet fifteen years old. The country still suffered from agitation, and in 1842 a dangerous insurrection was quelled by Gen. Caxias. Thenceforth the internal peace of the empire was not disturbed. In 1843 Dom Pedro was married to the Princess Theresa Christina Maria, daughter of Francis I., King of Naples. Of their four children, only one daughter still lives. She was married in 1864 to the Comte d'Eu, grandson of Louis Philippe, of France, and has three sons.

The emperor is remarkably well educated, and converses fluently in English, French, German, Spanish, Italian. Well versed in science and literature, he is liberal in promoting them in his dominions. In 1852 he assisted in the overthrow of the dictator Rosas in the Argentine Republic, and thereby acquired for Brazil an enlargement of territory and the free navigation of the Rio de la Plata. In 1860 he made extensive travels in all parts of his dominions. In 1865 Brazil, Uruguay, and Argentine Republic were compelled to unite in repressing the wild ambition of Lopez, the dictator of Paraguay. The war was only ended by the death of the savage dictator in 1870. A complication with the Argentine Republic ensued, but the matter was finally compromised in October, 1872. Meantime Dom Pedro had visited Paris, giving special attention to its scientific institutions. He also travelled in Spain, and in 1876 he made a tour in the United States and then visited Europe again. Everywhere he left the most favorable impressions of his courtesy, energy, scientific zeal, and public spirit. His reign has been signalized by the abolition of slavery. In 1831 the African slave-trade was prohibited, but practically it did not cease till 1853. Still more important was the decree for the abolition of slavery, issued Aug. 25, 1871. By its terms all slaves on the imperial estates were at once emancipated, and all the children of slaves of private owners, born thereafter, were declared free.

PEEL, ARTHUR WELLESLEY, Speaker of the British House of Commons, was born in 1829, being the youngest son of the famous Sir Robert Peel. He was educated at Eton and at Balliol College, Oxford, and entered Parliament in 1865 as member for Warwick, which he still represents. He was parliamentary secretary to the Poor Law board in 1868-71; secretary of

the Board of Trade in 1871-73; patronage-secretary of the treasury, 1873-74; under-secretary of the home department in 1880. He was chosen Speaker of the House in 1884 on the retirement of Sir Henry Brand, and was re-elected in 1886.

PEET, HARVEY PRINDLE (1794-1873), educator of deaf-mutes, was born at Bethlehem, Conn., Nov. 19, 1794. He graduated at Yale College in 1822 and became an instructor in the Hartford asylum for the deaf and dumb. His noble work there has been described under DEAF-MUTES. He died at New York city, Jan. 1, 1873. He published a useful *Course of Instruction for the Deaf and Dumb* (1844-46); *Legal Rights of the Deaf and Dumb* (1856); and other works connected with the cause to which he had devoted his life.

His son, ISAAC LEWIS PEET, was born at Hartford, in Dec. 4, 1824, graduated at Yale College in 1845, and at Union Theological Seminary in 1849. He and his brother EDWARD (1826-1862) followed in the footsteps of their father, and contributed to the literature pertaining to deaf-mutes.

PEKIN, city of Illinois, county-seat of Tazewell co., is on the left bank of the Illinois River, 10 miles below Peoria, and 163 miles S. W. of Chicago. Four railroads pass through the city. It has a court-house, 5 hotels, 2 national banks, 1 other bank, 2 daily and 5 weekly newspapers, 12 churches, and 6 schools. The industrial works comprise 2 foundries, flouring-mills, wagon-, plow-, and organ-factories, and 2 header-works. Pekin was settled in 1831, and incorporated in 1849. It has gas- and water-works, and a park. Its property is valued at \$1,250,000, the public debt is \$75,000, and the yearly expenses about \$45,000. Its population in 1880 was 5993.

PEMBERTON, JOHN CLIFFORD (1817-1881), Confederate general, was born in Philadelphia in 1817. He was descended from Phineas Pemberton, who came from England with William Penn, and whose family was prominent in Philadelphia in the eighteenth century. John graduated at West Point in 1837, served in the Florida and Mexican wars, being aide-de-camp to Gen. Worth in the latter. At the outbreak of the civil war he resigned his captain's commission and entered the Confederate service as colonel of cavalry and assistant adjutant-general to Gen. Joseph E. Johnston. In 1862 he was made brigadier-general, and then lieutenant-general, having command of the army in Mississippi. He was intrusted with the defence of Vicksburg when Grant began his campaign to recover the free navigation of the Mississippi. Pemberton was defeated at Champion Hills, May 16, 1863, in his attempt to keep open the way for reinforcement by Johnston's army. Thenceforth he was shut up in the fortifications of Vicksburg until July 4, 1863, when he was compelled to surrender to Gen. Grant. Being exchanged he resigned his command, but at the close of the war he was inspector of artillery at Charleston. Thereafter he lived in retirement in Virginia. He died at Philadelphia, July 13, 1881.

PEN. The history of the manufacture of steel pens in the United States covers a period of about thirty-five years. In June, 1853, William Gilchrist started his factory, which was located about 2 miles from Suffern's Depot, N. J., on the Erie Railroad, the power being furnished by water from the Ramapo Creek. This business was conducted successfully until November of the same year, when the factory was totally destroyed by fire. James Bishop, of Newark, N. J., purchased the salvage, and continued the business for a short period, when it was sold to a stock company known as the Newark Steel Pen Co. This concern did not prosper, but labor troubles arose, and owing to disagreements between the company and its employes, the company failed and the business passed into the hands of the Franklin Pen Co. of New York, a newly organized house. In 1855 the

American Steel Pen Co. began business in New York. Afterwards under the title of Washington Medallion Pen Co. this organization conducted the business until 1861, when Harrison & Bradford, of New York, purchased the plant. This firm continued the business for twenty years, and was really the first house to put the American manufacture of steel pens on a solid foundation. In 1881 this firm went out of business, Mr. Harrison becoming a member of the firm of Turner & Harrison, of Philadelphia, while Mr. Bradford became connected with the Miller Bros.' Cutlery Co., of Meriden, Conn. This house at that time began to make steel pens, Mr. Bradford being placed in control of the new department. In 1860 the Esterbrook Steel Pen Co. entered the field as manufacturers of steel pens, with an extensive factory at Camden, N. J., and this house is to-day the largest American maker.

These three houses, the Esterbrook Steel Pen Co., the Miller Bros. Cutlery Co., and Turner & Harrison, are now the only manufacturers of steel pens in the United States, and their combined annual output is about 1,500,000 gross, while of foreign pens the annual importation is about 600,000 gross.

The raw material used by these manufacturers is a fine crucible steel, produced in Birmingham, England, which is imported here both rolled and in the rough. When rolled it is in strips about 4 ft. long and 3 to 3½ in. wide.

The process of manufacture has changed but little all these years. The work is mainly hand labor, and whatever improvements have been made have been in the way of "raising" the pen and changing the side slits so as to secure greater flexibility. Each pen, in its progress from the blank to the finished article, is handled from 22 to 24 times, and in the case of some special pens the operations exceed these numbers. First, the pen blank is struck out of the rolled steel, after which it is "pierced" or has cut in it the little hole which is in the body of the pen, just above the slit in the point. It is then annealed and stamped either with the maker's or an "imprint" name. It is next "raised;" that is, it is rounded up and given its proper shape. It is then hardened and tempered, in which are included a number of operations. After this it is ground lengthwise to allow the ink to run to the point, and then cross-ground to hold the ink at the point and prevent it from dropping off. After the pen is scoured, the slits are cut in the point and sides, and the former of these is perhaps the most delicate of all the manipulations through which the pen passes. The finished pens are then assorted, each pen being examined, weighed into boxes, each containing a gross, and packed into cartons, each carton containing 25 gross.

In the early days of steel pens the demand was almost wholly for those with fine points, but with the necessity for rapid and easy writing came the call for the various grades of blunt, turned-up, round-pointed, and stub pens, until now some houses show a variety of 250 different styles. "Imprint" pens are those which have stamped upon them the name of the jobbing or retail stationer instead of the name of the maker. Formerly a large variety of "imprints" were made, and, while now the quantity has increased, the stamps are mostly confined to jobbers and retailers doing an extensive business.

Gold Pens.—The manufacture of gold pens in the United States dates from the spring of 1836, when Simon Hyde, an enterprising American, purchased the business of John Isaac Hawkins, an Englishman, who after years of patient study and experiment had succeeded in making a gold pen. Hyde bought the business for £300, and a royalty on all pens sold. Hawkins had taken out no patent, and for several years the process of manufacture was kept a profound secret by Hyde and his assistants. It finally leaked out and by 1849 there were fifteen firms engaged in the business, and from that time on rapid progress was made, the trade reaching its zenith about 1861, since which time

it has remained at about the same level. The gold pen to-day is practically the same as when Hawkins completed it, except that the goods are now made in a neater and more finely finished manner.

Fountain Pens.—In 1848 N. A. Prince, of New York, brought out the first fountain pen. This consisted of a metal barrel tapering to a point at the upper end; the lower end was round, the under side of the barrel being cut away, exposing to view and for use a small curved bit of rubber which was the writing point. A valve located just above the pen controlled the ink, and was opened or closed at pleasure. As soon as Goodyear produced his vulcanized rubber, Mr. Prince and his partner, John S. Purdy, secured the exclusive right to use that rubber for pen barrels. Since that time inventors innumerable have taken out patents on fountain pens, the result being that the market is now supplied with a great variety of styles. The general characteristics of all the pens are about the same, the variations being mainly in the methods employed to feed the ink to the pen.

The origin of the stylographic pen is obscure. It seems to have been developed by some one who was working to produce a fountain pen, and it is hard to distinguish between early specimens of the two instruments. The earliest record of a stylographic pen is the granting of a patent for one to Charles W. Krebs, of Baltimore, Md., in 1850. The pen was a crude affair. Six years later Nelson B. Slayton, of Madison, Ind., invented and patented a stylographic pen, but in 1869 one Kenyon invented a pen which was about the first bearing a resemblance in mechanical construction to those which followed and became popular. Inventors in this branch appear to be as numerous as in fountain pens, but the pens brought out of late years have a general similarity. (C. K. U.)

PENALTY, as a legal term, is used in two ways: 1. It denotes a clause in an agreement by which the obligor agrees to pay a certain sum of money if he shall fail to fulfil the contract contained in another clause of the same agreement. The most ordinary form of penalty is that named in a bond: it was originally inserted according to Blackstone to evade the prohibitions against taking interest for money, and was considered as part of the real debt. Penalties were then strictly enforced and continued to be so until courts of equity interfered and held that, upon the principle that compensation and not forfeiture was the just and equitable rule to be applied to all cases, they would grant the obligor relief when he had been prevented from paying the money on the day stipulated. Consequently, when the debtor paid the debt, with interest for its detention and costs, he should not be mulcted in further damages. Acts of Parliament were afterwards passed giving the courts of common law power to afford the same relief. These or similar statutes are in force generally in the United States.

There is frequently a question whether the sum named is a penalty or the amount of damages which the parties have agreed shall be recovered, in case of a breach of covenant. Against such stipulated or liquidated damages equity will not relieve. The general rule has been said to be that "when the injury is susceptible of definite admeasurement, as in all cases where the breach consists in the non-payment of money, the parties will not be allowed to make a stipulation for a greater amount, whether in the form of a penalty or of liquidated damages. But when, on the other hand, the injury in question is uncertain in itself and unsusceptible of being reduced to certainty by a legal computation, it may be settled beforehand by special agreement." In all cases it is a question of intention.

It has been held that a penalty remains unaffected though the condition may have been partially performed, as where the penalty was \$1000 and the condition to pay an annuity of \$100, which had been paid for ten years; the penalty was still valid.

2. Penalty is also the term used for the punishment inflicted by a law for its violation; a pecuniary punishment is generally meant, though the phrase "death-penalty" is also in common use. (T. R.)

PENCIL. This article is confined to the manufacture of lead pencils in America. M. L. Leman, of New York, was the pioneer manufacturer of lead pencils in the United States. He began the business in 1830, and his workmen were distributed in Jersey City, Hoboken, and other places adjacent to New York. The old system of all handwork was then in full force, the workmen taking the pencils home to "finish," the making of the pencil in the rough being carried on at a central place.

In 1849 Eberhard Faber came to New York as the agent of A. W. Faber, of Stein, Germany, and in 1861, the centennial of the house, it was determined to found the industry in America. This was done, the plant being located in New York city, but in 1872 the factory was burned down and a new one was built at Greenpoint, L. I. This move of Faber was really the start of the pencil industry in this country. In 1865 the Eagle Pencil Co. began the manufacture of pencils in America, all their goods before that time having been imported. In 1865 the American Lead Pencil Co. entered the field, and was followed in 1872 by the Dixon Crucible Co., and to-day these are the only makers in the United States.

With the exception of the American graphite used by the last-named company all of the pencil lead used in this country comes from abroad, the chief mines being in Bohemia, although one maker has the output of the Alibert mine, Siberia, which is used in certain grades of artists' pencils. The clay which is mixed with the lead to give it a proper texture comes from Bavaria and Bohemia, the finer grade being from the former place. The clay is of a brownish color and possesses fatty qualities, being oily or greasy when rolled in the fingers. The wood used in the great majority of grades is cedar and the supply of that wood used by all pencil-makers the world over comes from Florida. Other woods are used to a slight extent, but none of them work so well under the knife when sharpening the pencil as the cedar. The American inventive genius has been shown in this industry as in others, and while the laborer in Europe produces one pencil at a time the American machine produces six, and in the subsequent finishing of the pencil hand-labor is reduced to a minimum. The lead pencil of to-day is practically the same as when first produced in 1565 in England. It is made neater, finished better, but is essentially the same. (C. K. U.)

PENDER, WILLIAM DAVIDSON (1834-1863), a Confederate general, was born in North Carolina, and graduated at West Point in 1854. He entered the artillery, but was soon transferred to the dragoons and was employed in frontier service until the secession of North Carolina, when he entered the Confederate service as colonel. He was afterwards promoted to be brigadier-general and major-general (May 20, 1863). He had command of a division at the battle of Gettysburg, and was killed there, July 3, 1863.

PENDLETON, EDMUND (1721-1803), a Virginia patriot, was born in Caroline co., Va., Sept. 9, 1721. He was of English descent, and early engaged in the practice of law. In 1752 he was elected to the House of Burgesses and was prominent in the patriotic movements preceding the Revolution. In 1774 he was a member of the first Continental Congress, and he presided in the Virginia Conventions of December, 1775, and May, 1776. He drafted the resolutions instructing the delegates of Virginia to propose in Congress a declaration of independence. During the war he was chairman of the Virginia Committee of Safety, and when the State was organized he was made speaker of the House. He also presided over the State convention which ratified the Federal Constitution, and strongly

supported this document against the objections of Patrick Henry. From 1779 till his death, Oct. 23, 1803, he was president of the Court of Appeals.

PENDLETON, GEORGE HENRY, statesman, was born at Cincinnati, July 19, 1825. His grandfather, Maj. Nathaniel Pendleton, had been aide to Gen. Greene, in the revolutionary war, and afterwards judge in New York. His father, Nathaniel Greene Pendleton (1793-1861), likewise had been aide to Gen. Gaines in the war of 1812, and member of Congress from Ohio, 1840-42. George was educated partly in Europe and became a lawyer. He was elected to the Ohio State senate in 1854, and passed thence to Congress in 1855, where he continued as a pro-slavery Democrat until the outbreak of the war. Then he was defeated for re-election, but returned in 1863, and opposed the prosecution of the war. In 1864 he was the Democratic candidate for vice-president, on the ticket with Gen. McClellan, but was defeated. Soon after the close of the war he became the most prominent advocate of the proposal to pay the U. S. bonds in "greenbacks," and as such was strongly pressed upon the Democratic convention of 1868 as a candidate for the presidency, but this movement failed. In the next year he was candidate for the governorship of Ohio, but was defeated. In 1879 he was elected to the U. S. Senate, where he was an able advocate of civil service reform. On the expiration of his term in 1885 he was appointed U. S. minister to Germany.

PENINSULAR CAMPAIGN, McCLELLAN'S.—After the disastrous defeat of Gen. McDowell, at Bull Run, July 21, 1861 (see BULL RUN), Gen. George B. McClellan, who had distinguished himself in West Virginia, was called to Washington and put in command of the troops collected there for the defence of the national capital. He found there 50,000 men, mainly newly levied or demoralized. Two things were clear to him. A large army must be created, and Washington must be fortified to set at rest apprehensions for its safety. These objects were not accomplished till the spring of 1862, and, meanwhile, on Gen. Scott's retirement on Nov. 1, 1861, Gen. McClellan had been made commander-in-chief of the forces of the Union. In the early spring of 1862 McClellan had under his immediate command 180,000 men organized into four corps, under the name of the Army of the Potomac. The enemy threatening the capital numbered 75,000, under Gen. Joseph E. Johnston, whose head-quarters were at Manassas Junction. His right wing rested on Aquia Creek and supported the batteries that blocked the Potomac. McClellan's first plan was to draw Johnston from his lines by transporting the Army of the Potomac to Urbanna, on the Lower Rappahannock, and moving it thence on Richmond. If he failed to carry Richmond by a *coup de main*, his ulterior purpose was to march to the James, and with that river as a base to assault the city in the rear. This, he conceived, by compelling Johnston to fall back on Richmond, would secure the capital, relieve the blockade of the Potomac, and open the communication between Washington and the West, now interrupted at Harper's Ferry.

Unfortunately the government had no longer unlimited confidence in its commander, and a positive order required him, before moving from Washington, to open the Baltimore and Ohio Railroad and destroy the batteries on the Potomac. The first of these objects he effected in the end of February, and almost immediately on his return to Washington intelligence reached of Johnston's abandonment of Manassas for the Rapidan. Thus the Potomac was freed, while the operations of the Monitor, near the mouth of Chesapeake Bay, enabled McClellan to look more confidently to the James River as a base.

Johnston's move southwards deprived the Urbanna scheme of its promise, for he could now reach Richmond before the Union army. The alternative was to adopt Fortress Monroe as a base, and, on March 17,

the leading divisions of what was meant to be an army of 155,000 were embarked at Alexandria. Precisely at this time McClellan was deprived of the command-in-chief, while his army by the withdrawal of troops for the defence of Washington was reduced to 120,000. On April 2d he reached the fort and found 58,000 men and 100 guns disembarked and ready to march, and at once took steps to advance up the Peninsula.

On April 1, 1862, the status of the army was as follows:

Second corps—Sumner.....	26,778
Third corps—Heintzelman.....	33,047
Fourth corps—Keyes.....	32,924
Regulars—Sykes and Cooke.....	5,906
Reserve artillery.....	2,731
Different corps.....	900
Sick.....	6,453
Absent.....	10,616

119,965

The disembarkation was completed on April 6th, when there were slightly over 100,000 men, with 44 batteries on the Peninsula, fit for service.

Fortress Monroe is 72 miles in a direct line S. E. of Richmond. The field of operations lay between this and the Upper Chickahominy on the north, and between the James River on the S. W. and the York and its main branch, the Pamunkey, on the N. E. The region divides itself into two parts—the Peninsula proper between the York and the James as far up as City Point, and the tract between the Pamunkey and James stretching above Richmond. In the former the land is flat, marshy, and thickly wooded. The second is undulating and divided longitudinally by the Chickahominy. The James was blocked by the Confederate iron-clad Virginia, formerly called the Merrimac; the York and Pamunkey could be ascended by vessels as far as White House, but the entrance was blocked by the guns of Yorktown. Hence the importance of this place. The secondary peninsula on which it stands is narrowed by a swampy stream, Warwick Creek, that rising about 1½ mile from the town empties perpendicularly into the James. Here nature marked out the Confederate true line of defence. Yorktown is 20 miles N. W. of Fortress Monroe, and Williamsburg 10 miles farther in the same direction.

On the 4th McClellan put his troops in motion, and his right appeared before Yorktown next day. His left was detained by the unforeseen obstacle of Warwick Creek, incorrectly laid down on the maps, along which was Magruder's line of defence extending 12 miles in length. His force of 11,000 men was evidently too small to hold a line of this length against the powerful army of his antagonist, and the fortifications of Yorktown were insufficient. Johnston urged evacuation and the concentration of all the forces in Richmond. To this Magruder would not listen. His obstinacy led McClellan to believe that he had been reinforced by part of the force from Manassas, and he deemed it prudent to wait for McDowell's 3 divisions, which had been promised him. On the very evening he was reconnoitring he was apprised that this whole corps was withdrawn from him and that Wool, who held Fortress Monroe with 15,000 men, had been made independent. The naval force on which he had relied for co-operation on the York failed him on the pretext of watching the Virginia. He hesitated and delayed, while Johnston sent part of his forces to help Magruder, following ultimately in person. When, therefore, after 11 days, McClellan decided to attack, Magruder's force was doubled. Yet the disproportion was not materially affected. The men embarked at Alexandria were now all in the Peninsula, and Franklin's division of McDowell's corps was restored to him.

On April 16th a general cannonade was opened and an attempt made to storm the breastworks. This resulted in failure and McClellan determined to proceed by regular siege. On May 5th everything was ready

for the bombardment, when it was discovered the foe had disappeared. Yorktown had been evacuated on the night of the 4th of May, in accordance with the decision of a council of war, in which Davis, Lee, Johnston, and Magruder took part. Seventy-one guns were the trophies abandoned to the Union army.

In evacuating Yorktown the Confederates abandoned York River, and Franklin's command was taken on board transports to be landed at White House, at the head of the navigation of the Pamunkey. McClellan conducted the pursuit by land. The task of covering the Confederate retreat was intrusted to Longstreet, under whom it was conducted with the greatest order. At Williamsburg defensive works had been constructed, the most prominent being a large work named Fort Magruder, nearly 2 miles in advance of the town. This and the chain of adjoining works were occupied by the Confederates, who saluted the on-pressing columns as they appeared on the edge of the forest with a fierce fire. The appearance of the numerous works was a surprise to the Unionists. Longstreet had manned them during the night, resolved to maintain possession. Hooker attacked his right, and Longstreet's artillery crossed its fire with that of the Confederate infantry. The Unionists in the open unable to withstand the cross-fire ambushed themselves among the abatis which became the scene of a fierce struggle. Hooker lost the abatis and was falling back when Kearney came to his aid. Allowing Hooker to pass between his battalions he took up the fight, and arrived in time to rescue one or two abandoned batteries. Towards 4 o'clock the right came into action, and Hancock, finding a small redoubt—a link in the Magruder chain—unoccupied, took possession of it, and his men pressed on till they arrived in view of the Confederate left. Longstreet, on discovering Hancock, despatched Early's brigade against him, but this was driven back in disorder. McClellan, who had remained behind to see Franklin off, arrived before Williamsburg too late for further action that night. He saw that the Confederate defences were turned and prepared for a vigorous assault on the morrow, but Johnston, conscious of his numerical inferiority, evacuated his defences and during the night resumed his retreat. The Confederates had 3000 men disabled, and left 600 prisoners. The Union loss was 2073 killed and wounded and 623 prisoners.

Franklin's division, which had embarked on the evening of the 5th, arrived at Elkhorn near White House on the 6th, but, on attempting to advance on the 7th, he was confronted by Whiting's Confederate division and Hood's brigade. This served to hold him in check, and Johnston reached Richmond without further molestation.

On the retreat of the Confederates from Williamsburg the Army of the Potomac was pushed forward as rapidly as the horrible condition of the roads would permit and on May 16th its leading divisions reached the White House, whence the West Point Railroad runs west to Richmond, 18 miles. Here McClellan established his depots, and by the 21st had his army established in echelon along the left bank of the Chickahominy. Johnston, meanwhile, had pressed forward the concentration of all available Confederate forces at Richmond, and had in consequence been joined by Huger with 11,000 men from Norfolk. Huger's abandonment of Norfolk led the Confederate Commodore Tatnall to blow up the Merrimac, thus leaving the James open to the Union gun-boats. McClellan was thus confirmed in his ulterior purpose of transferring his base to the James, and co-operating with Goldsborough in an attack on Richmond on the south. This purpose he would have carried out on the evacuation of Williamsburg but for an object to which high importance was attached, viz. : the insurance of a juncture with McDowell when he should move from Fredericksburg. With this object, as well as for the preservation of his communication with the White

House, he had to leave his centre and right wing on the north bank of the Chickahominy, when he on the 20th commenced to cross the rest of his army at Bottom's Bridge. At this moment McDowell's movement had really commenced, and Porter had marched to meet him as far as Hanover Court-House (where he had a combat and captured 700 prisoners and a gun), when Jackson's irruption into the Shenandoah alarmed the authorities for Washington and led to McDowell being countermanded, with his 41,000 men.

The ground of McClellan's immediate operations may be described in a few words. It presents but one obstacle, the Chickahominy, rising to the north of Richmond. In its downward course we meet first Meadow Bridge (over which passes the Gordonsville Railroad); below this is Mechanicsville Bridge, within 5 miles of the city; then New Bridge, connecting the hamlet of Old Tavern with Gaines' Mill heights; 6½ miles below this is the bridge of the West Point Railroad, and two-thirds of a mile farther down, Bottom's Bridge, 12 miles from Richmond. Here McClellan had crossed his left wing. The noticeable tributaries of the Chickahominy are Beaver-Dam Creek between Mechanicsville and Gaines' Mill on the left bank, White Oak Creek, giving rise to a vast wooded swamp, called White Oak Swamp, some 3 miles below Bottom's Bridge.

On the 28th McClellan had his left wing (Keyes and Heintzelman) on the south bank stretching from White Oak Swamp up to the railroad bridge; Sumner at the centre stood prepared to cross but his bridges were not laid; the right wing under Franklin and Porter stretched northward on the left bank as far as opposite Richmond. His whole line formed a semi-circle, broken near the centre by the Chickahominy and with the extremities 25 miles apart. The Confederates occupied the chord. Johnston was not the man to let slip an opportunity so full of promise for an attack, and accordingly on the 31st delivered an assault at Fair Oaks Station. (See FAIR OAKS, BATTLE OF.) Johnston's serious wound in this action led to the appointment of Gen. Robert E. Lee to the Confederate command-in-chief.

The battle of Fair Oaks (during which Sumner had crossed to the south side) was followed by storms, lasting till June 20th, that enforced rest on both combatants. The only events calling for note were Stuart's cavalry reconnoissance round the whole rear of the Federal line with his raid on the railroad and White House, and the transfer of Franklin's corps on the 19th to the south bank, Porter, reinforced by McCall, being left alone north of the river.

By June 26th the ground was dry enough to admit of operations. Lee supposed that McClellan's object in bringing his forces across the Chickahominy was to lay regular siege to Richmond. His cadres had now been filled up by the enforcement of the conscription in the South and by further reinforcements, and he proposed to raise the siege by threatening the Union line of communication with White House. The armies by which the aims of either general were to be executed were nearly equal, numbering each a little over 100,000 men present for duty.

The following is a summary of the effective strength of the two armies on June 26, 1862:

Union.		Confederate.	
Sumner,	17,581	A. P. Hill,	14,000
Heintzelman,	18,810	D. H. Hill,	10,000
Keyes,	14,610	Longstreet,	10,000
Porter,	19,960	Magruder,	13,000
Franklin,	19,405	Huger,	11,000
McCall,	9,514	Holmes,	7,000
Staff, Engineers,		Jackson,	30,000
Cavalry, etc.,	4,844	Pendleton's Art'y,	1,500
		Stuart's Cavalry,	4,000
	104,724		
Deduct losses since			100,500
June 20, say	1,500		
	103,224		

On the evening of the 25th McClellan was startled by tidings that Jackson was at hand and threatening his rear, and that A. P. Hill (who with Longstreet and D. H. Hill were designated by Lee to effect a junction with Jackson and break up McClellan's communications) had concentrated his division opposite the Union extreme right at Meadow Bridge. By 8 next morning Longstreet and D. H. Hill reached their posts in front of Mechanicsville. All waited the advance of Jackson. He, however, was delayed by Union skirmishers, and Hill becoming impatient, crossed the river at 3 p. m. and pushed down the north bank till he arrived opposite Longstreet and D. H. Hill. They also crossed and joined him, whereupon the Union advance fell back from the village to a position beyond Beaver-Dam Creek.

The position, a strong one, was held by McCall. The creek was passable by artillery only by two bridges, one near its mouth at Ellison's Mill, the other a mile higher. It could be attacked in front only with heavy loss, but it could be turned on the right. A. P. Hill, supposing this to have been done by Jackson, marched across the open swept by the Union batteries, and assailed McCall's line, first on the right at the upper road and, failing there, then on the left at Ellison's Mill, where he was repulsed even more disastrously than on the right. At 9 o'clock the Confederates, beaten back at all points, fell back out of range and the combat of Mechanicsville, the first of the "Seven Days' battle" was at an end. Their loss was 250 killed and 1250 wounded; that of the Unionists 300 in all.

McClellan now gave up all thought of maintaining the north bank of the Chickahominy, and McCall and Porter were directed to abandon the position at Beaver Dam and take up a new one with Cold Harbor as their centre, five miles farther down, the sole object being the protection of the railroad along which the stores were being conveyed from White House for transference to the James.

On the morning of June 27th Porter and McCall, reinforced by the half of Franklin's corps, stood ready for action. The Confederates left Mechanicsville at dawn, but the bridges over Beaver Dam being down, it was noon ere they accomplished five miles. Passing Gaines' Mill (where a skirmish occurred which has given name to the whole engagement) they came in sight of the Union force drawn up on a hill-side across an unnamed creek. It was past 2 o'clock when the action began by A. P. Hill dashing across the intervening plain and swamp in the face of a fierce artillery fire and passing close up to the Federal infantry lines. For two hours the conflict raged, but the Confederates were eventually defeated and driven back. Jackson came now into view along with D. H. Hill, who had formed a junction with him. Longstreet, who had been held back for Jackson's approach, now joined himself with these, and an advance was ordered of the whole line. The assault was first made on the Union right held by Sykes with his regulars, and by 6.30 p. m. the whole Confederate force of 56,000 men was pressing on the Union line of 30,000, on right, centre, and flank simultaneously. The line gave way at every point, and its retreat threatened to become a rout, when French's and Meagher's brigades burst through the stragglers thronging to the bridge over the Chickahominy and advanced to what was now the front. The fugitives rallied; the Confederates paused in the pursuit, and after a few volleys the battle of Gaines' Mill was over. The Union loss was 675 killed, 3250 wounded, and 2000 men and 20 guns captured; the Confederate, 1500 killed and 8000 wounded.

When day broke on the 28th the whole Union force was across the river and the bridges broken. The problem before McClellan was how to transport his immense stores and trains to the James, some 17 miles from his head-quarters. During the night of the 28th his whole force was put in motion, while Lee, on

comprehending his object, ordered his entire force to start in pursuit. By dawn of the 29th all his columns were reinitiated on the S. bank and in motion, and in the afternoon Magruder came in sight of Sumner's corps drawn up as a rear guard at Savage's Station. A smart conflict of two hours ensued, with the sole result that while Sumner stood at bay the mighty Union caravan was passing White Oak Swamp and wending its way towards Malvern Hill. During the night the rear guard crossed the swamp, and Jackson, who arrived there on the 30th, found the bridges destroyed, and on trying to force his way across met with such resistance from Franklin, who stood on the farther side, that he was compelled to desist. Lee's object was to strike the Union line at its centre, break it and hurl its left wing back on Jackson. With this view Longstreet had flanked the swamp, and hurrying forward came on the line drawn up at Frazier's Farm. Supported by A. P. Hill, he charged with all his wonted impetuosity. Other divisions came up and the battle raged all along the line, night alone putting an end to the struggle. The Confederates slept on the field, having captured 20 guns as well as Gen. McCall, but the grand result of the action was to insure the integrity of McClellan's army. The troops that had checked Jackson and repulsed Longstreet withdrew during the night, and when Lee was next able to strike, it was at a united army posted on the strong position of the elevated plateau or heights of Malvern, and in close communication with its base on the James. Jackson had crossed the swamp and with all the other Confederate leaders was present at the battle that ensued. In the afternoon of the 1st of July Lee ordered an artillery attack, but this was made by only one battery, which was instantly shattered. Columns of attack led by D. H. Hill, Magruder, and Ewell repeatedly charged furiously in the attempt to establish themselves on the table-land. All failed to make any impression, or even disturb a single battery. The Confederates persisted in their desperate efforts till dark, when, repulsed everywhere with fearful loss, they ceased from the struggle, and the Union troops stood victors on Malvern Hill. During the night they were withdrawn to Harrison's Landing on the James, and the Seven Days' battle was ended. Neither Longstreet, A. P. Hill, nor Jackson took part in the fight. The loss on the Union side was 375 killed and 1800 wounded; that of the Confederates, 900 killed and 3500 wounded. The total loss from June 25th to July 2d (the Seven Days' battle) was, on the Union side: killed 1734, wounded 8062, missing 6053 = 15,849; on the Confederate side, killed 2823, wounded 13,223, missing 3360 = 19,406. At Harrison's Landing McClellan found himself at the head of from 85,000 to 90,000 effective troops, and purposed, in conjunction with the naval force, a grand attack on Richmond in the rear. On Aug. 3d he received a telegram from Halleck, now general-in-chief, ordering him to withdraw from the Peninsula, and his campaign there was at an end.

As a master of the art of war and an organizer, whether of an army or the complicated plans and operations of a campaign, it may be questioned whether McClellan had a superior among the generals in the great civil conflict, and certainly no one of them more entirely won the love and confidence of his men. But his military skill and organizing power as well as his faculty for winning men's hearts were largely neutralized by defects that operated to prevent him showing the qualities of a general of the first class. The most prominent of these was his inability in a critical moment to act with Napoleonic decision, swiftness, and effect. He halted between two opinions and hesitated, and so, more than once, let his opportunity slip. Thus, within little more than a day after his appearance before Yorktown he was at the head of over 100,000 men, with a splendid artillery, while Magruder lay behind his imperfect defences with but 11,000.

Of these, 6000 were in garrison in Yorktown, Gloucester Point, and Mulberry Island, leaving only 5000 men to defend his long line of 13 miles. McClellan was then in a position either to have turned Yorktown or to have broken Magruder's thin line by a direct attack. He hesitated and waited, and the result was that when he abandoned the former plan Johnston had come, and it was too late to attempt the other. "To my own surprise," says Magruder, "he let day after day pass without attack." Had he shattered Magruder and followed close on his heels to Richmond he might have carried it in its then comparatively weak state by the *coup de main* he dreamed of.

Again, the fundamental error of his selection of the White House as a base was that it made it necessary for him to have a force on the left bank of the Chickahominy to protect his line of communications. This crippled him for striking Johnston with a force so preponderating as practically to ensure victory. The moment all reasonable prospect of a junction with McDowell vanished, he ought to have transferred his depots and every man to the right bank, or at once have carried out his James River scheme. It was not till Lee was joined by Jackson and had replenished his ranks by conscription that there was any parity between the forces. "Gen. McClellan," says an able and friendly critic, "knew that the one course or other was necessary, but unfortunately the case was one presenting an alternative, and it was the nature of that commander's mind so to balance between conflicting opinions and let 'I dare not wait upon I would,' that he was apt to hesitate even in conjunctures where the worst course was preferable to doing nothing."

Again, during the battle of Fair Oaks McClellan lay with two army corps at his command at his headquarters at Gaines' Mill, whence he could see the smoke of the battle as it indicated the steady advance of the enemy. He could have left one corps to defend his communications and struck the Confederate flank with the other so as to turn Fair Oaks into a great victory. By consenting to defer, he lost an opportunity unexampled in the course of the war.

Military critics blame him for letting slip two other opportunities when he was lying on the south of the river. First, by not making a dash at Richmond when Lee had, on June 11th, sent Whiting to join Jackson in the Valley: and again, by lying supine when Longstreet, the two Hills, and Jackson with 60,000 men were attacking Porter and McCall with only 27,000, on the north bank, and he with a force equally preponderating over Lee's, was within easy striking distance of him.

As an evidence of his want of promptitude we may note Stuart's raid, which, with a Grant, a Sheridan, or a Thomas, would have been impossible. One thing is to be said for McClellan, that he acted under the conviction that he was subject to mistrust, and even to dislike, in high quarters, and that the worst construction would be put on any error. In a man of his temperament this feeling, no doubt, tended to paralyze action. On the whole it may truthfully be said that, although the campaign, viewed with regard to its aim, was a failure and left the prestige of victory with the Confederates, McClellan, in the conduct of his operations, showed the skill of a finished general; no one was more conscious than Lee of the adroit manner in which his antagonist parried his blows. His retreat, with endless trains of wagons and ambulances and 2500 live cattle over miserable roads (sometimes only one), and guarded by an army hungry, weary, and footsore, was executed in a manner to reflect the highest honor on commander and soldiers alike. "For the commander," says the Comte de Paris, "to have extricated his army from a difficult situation, in which circumstances as much as his own fault had placed it, and, in presence of a powerful, skilful, and determined adversary, transfer it safely to a position whence it could act with effect, was of itself a notable

achievement. With an ordinary man, the Army of the Potomac would have been destroyed." (J. H.)

PENN, JOHN (1741-1788), a signer of the Declaration of Independence, was born in Caroline co., Va., May 17, 1741. His early education was neglected, but he read law with Edmund Pendleton and was admitted to the bar in 1762. He was soon noted for his eloquence. In 1774 he removed to Greenville co., N. C., and was sent as a delegate to the Continental Congress, in which he signed the Declaration of Independence. He was again a member of Congress (1778-80), and when Lord Cornwallis invaded North Carolina Penn had charge of the affairs of the State. He died in September, 1788.

PENNINGTON, WILLIAM S. (1757-1826), judge and governor, was born in 1757 and served in the revolutionary army as major of the Second New Jersey artillery. After the war he became a lawyer, and in 1804 was made associate justice of the State Supreme Court. He was elected governor in 1813, and at the close of his term was made U. S. district judge. He died at Newark Sept. 17, 1826.

His son, WILLIAM PENNINGTON (1796-1862), graduated at Princeton in 1813, and studied law. He was clerk of his father's court (1815-26), became chancellor of the State, and from 1837 to 1843 was governor. In 1859 he was elected to Congress as a Republican, and his nomination by his party friends for Speaker of the House led to a struggle protracted through eight weeks and terminated in his favor Feb. 1, 1860. He served with ability in the trying times of the secession movement. He died at Newark, Feb. 16, 1862.

PENNSYLVANIA has, since the United States census of 1830, held the second rank among the States of the Union. It then outstripped Virginia, originally the leading State in population and importance, as New York had done in the census of 1820. The census of 1880 gave Pennsylvania a population of 4,282,891, which has since 1883 entitled the State to 28 representatives in the National Congress. After an abortive effort in 1885, a new arrangement of Congressional districts was made by the Legislature in 1887. The population has now increased beyond 5,000,000. To the excellent account of the State in the *ENCYCLOPÆDIA BRITANNICA* the following additions should be made:

Finances.—The public debt of the State on Dec. 1, 1887, was \$15,840,471.28, since which period there has been a redemption of nearly \$1,500,000. As an offset it may be noted that the Pennsylvania Railroad Company owes the State on the purchase of the internal improvements, originally made by State authority, \$9,000,000. Of the funded debt about \$5,250,000 drew 5 per cent. interest, and the rest 3½ and 4 per cent. The annual revenues of the State from all sources in the year ending Dec. 1, 1887, were \$7,498,125.54, while the expenses on State account were \$7,262,805.66. By law about \$1,500,000 annually passes into the sinking fund established for the payment of the State debt. The total amount raised by taxation for State purposes was \$6,495,704.26. Real estate, which is not taxed for State purposes, was valued at \$1,697,202,153. The stock and income of corporations were valued at \$1,200,000,000, and from taxes on this valuation most of the State revenues are derived. Personal property is assessed at \$263,814,762. The State tax-rate is 40 cents on \$100. The aggregate taxation for all purposes, general and local, is \$38,000,000.

From an early period the State liberally supported the various measures adopted to open communications



between the seaboard and the West. The system of canals and railroads completed in 1834 was the great means of developing her internal resources. The present State debt, although rapidly decreasing, remains as a result of her early enterprise in this direction.

In 1888 there were in the State 283 National Banks, and 79 banks and savings institutions with State charters. The paid-up capital of these various financial institutions exceeds \$90,000,000, with an outstanding circulation of about \$60,000,000.

Education.—In 1887 the number of school districts in the State was 2281. The estimated value of school property was \$36,991,147. In November, 1888, the percentage of population, over ten years of age unable to read, was less than 4 per cent.; unable to write only 6 per cent.

In 1864 the Pennsylvania Railroad Company donated the sum of \$50,000 for the support of the orphan children of the deceased soldiers in the war for the Union, and soldiers' orphans' schools were established by the State. Upwards of 17,302 children, of both sexes, have been educated in the various schools organized for this purpose. At present there are eleven schools located in various parts of the State. The number of children now being cared for, as appears by the roll for May, 1888, is 2249. From the period of the establishment of the schools down to the present time over \$10,000,000 have been appropriated and expended by the State. In addition to the sum annually appropriated for educational purposes directly about \$200,000 are appropriated for the education and maintenance of the deaf, dumb, blind, and feeble-minded of the State. The State College, formerly the Pennsylvania Agricultural College, and the Normal Schools established for the education of teachers, are liberally taken care of. In addition to the various colleges and universities schools for the special study of Science, Theology, Law, and Medicine are numerous, while there are upwards of 400 private academies and seminaries.

Although the recent records of the prisons, reformatories, and penitentiaries do not show an increase in crime proportionate to the estimated increase of population since the census of 1880, the almshouses give a marked increase in pauperism, and the number of insane persons has increased in even ratio with the population. This, however, is attributed to the better knowledge on the part of the people of the provision made by the State for this afflicted class, and greater willingness to avail themselves of it. Almost \$1,000,000 are annually appropriated to the various charitable institutions of the State, among which are the Soldiers' Home, recently established at Erie, and the Miners' Hospitals, which are solely under State direction. Various local hospitals are also provided for.

Manufactures.—Since 1880 the manufacturing industry of the State has been nearly doubled. The capital invested, cost of material, the total sum paid in wages to the number of persons employed, and the value of products is proportionately increased. This is particularly true in regard to the iron and steel manufactures, which have always been prominent in Pennsylvania. The utilization of natural gas for manufacturing purposes has given a special stimulus to many branches of industry, and has transformed the aspect of the region where it is abundant. The mining industry has also been increasing rapidly.

Railroads.—The total number of miles of railroad operated in Pennsylvania in 1888 is 9714. The aggregate length, however, of all tracks in the State exceeds 15,000 miles. The total cost of these roads and equipments exceeds \$1,013,450,000, not including the value of real estate held by the various companies, and also exclusive of roadway, which rises upwards of \$3,000,000. The total number of miles operated by these various companies amounts to 15,864 miles. The number of through passengers carried over these roads in 1887 was 4,525,612; the number of local passengers was 59,562,071, yielding a revenue of

\$39,819,422 from passenger traffic alone. The number of tons of through freight carried, exclusive of coal, was 40,633,688 tons, while that of local freight exceeded 100,000,000 tons.

During the year 1887 there was shipped over the various railroads of the State the following: Anthracite coal, 54,952,699 tons; bituminous coal and coke, 44,783,031; petroleum and other oils, 3,389,799 bbls.; pig-iron, 6,468,934 tons; railroad iron, 2,419,524; other iron or castings, 5,990,924; iron and other ores, 10,204,837. This is exclusive of the various products consumed at the place of supply.

There are also 519 miles of street passenger railways operated in the various cities of the Commonwealth. These have been constructed at an expense of \$12,326,068.

Canals.—Although the system of canals is gradually giving way to that of the railroads there are at present operated within the limits of the State 778 miles, of which 198 miles are slack-water navigation. The gross amount of tonnage passing over this system during 1888 exceeded 10,000,000 tons, and the receipts of tolls for the same were \$2,675,349.

The length of the main line of the Western Union Telegraph Company in Pennsylvania exceeds 9000 miles, while that of the Philadelphia and Reading system amounts to 870 miles.

Historical Notes.—When the province of Pennsylvania was settled by the English and Welsh Quakers under Penn a remnant of Swedish colonists was found along the Delaware. German and Swiss immigrants followed in succession. To them the State owes its character for industry and thrift.

The Scotch-Irish settlers from the North of Ireland came during the eighteenth century and were placed on the frontier counties of the province. To them the State owes its energy and intellectual culture. New Englanders, under the "Connecticut Claim," located in Wyoming, while the settlers in the western part of the State were made up of these diverse elements, the Scotch-Irish predominating. Owing to these heterogeneous elements the history and character of the State have often been misunderstood. Writers in many instances have failed to give proper credit to Pennsylvania for its contributions to the progress and welfare of the Union.

During the French and Indian War, from 1754 until 1764, owing to constant inroads made upon frontier settlements by marauding savages, from two to four regiments of provincials were constantly in the service. Three-fourths of these were Scotch-Irish settlers and residents on the frontier. In the Revolution, although Pennsylvania did not furnish as many troops for the Continental line as several other States, her large number of associators and militia in active service exceeded nearly all the States of the Union. The so-called revolt of the Pennsylvania line in January, 1781, was caused by the fact that the soldiers who were enlisted for three years, or during the war, were kept in service beyond the time for which they had enlisted, viz., three years.

With the exception of the railroad riots of 1877, which, at that time, extended widely over the United States, the disturbances in Pennsylvania have been merely local affairs, and do not warrant the assertion that they were caused by any general dissatisfaction with the Government or with the laws of the land.

The first State Constitution framed was in 1776, when the Proprietary Government ceased. Slavery was abolished in 1780. In 1789 the Constitution was revised; again in 1837-38; and finally in 1874. The latter revision was ratified by over 100,000 majority. Its new features are limiting the term of the Governor to four years (ineligible to re-election), providing for a Lieutenant-Governor, with various other officers to be elected by the people, increasing the number in the legislative body, and in several of the county offices providing for minority representation. (W. H. E.)

PENNSYLVANIA, UNIVERSITY OF. This institution, established in Philadelphia, claims as its founder Benjamin Franklin. In 1749 he issued anonymously *Proposals Relative to the Education of Youth in Pennsylvania*, which led influential citizens of Philadelphia to form an association and raise over £2000 for the purpose of an academy. A building which had been erected to accommodate the congregation of Whitefield was purchased and opened as "The Academy and Charitable School" in 1751. It contained an English, a Mathematical, and a Latin School. Two years later a charter was obtained from Thomas and Richard Penn, the proprietors of Pennsylvania. Rev. William Smith, a graduate of the University of Aberdeen and a clergyman of the Church of England, was invited to take charge of the academy. Such was his success that in 1755 a new charter was granted, raising the school to the dignity of "The College and Academy of Philadelphia." Its first commencement was held in 1757, when seven young men received the degree of Bachelor of Arts. Provost Smith made two visits to England in behalf of the College, and obtained for its use more than £6000, while the University of Oxford conferred on himself the degree of D. D. The College received other donations and legacies, yet for the erection of its own building in 1762 the trustees availed themselves of a lottery, a plan then not unusual with religious and charitable enterprises. Rev. Francis Alison (1705-1772), a Scotch-Irish Presbyterian minister, was the vice-provost of the college from 1755 until his death. Rev. Ebenezer Kinnersley, who shared in Franklin's electrical experiments, taught oratory and English literature. In 1765 a medical school was projected and it became an important part of the institution. Its growth will be noticed later in this article.

During the Revolution Provost Smith adhered so firmly to the British Parliament and the Proprietors that the Legislature of Pennsylvania caused his arrest and imprisonment, but he received and instructed his classes even while in jail. In 1779 the Legislature, in the excess of its patriotic zeal, annulled the charter of the college and bestowed its rights and properties on the "Trustees of the University of the State of Pennsylvania." Liberal grants were also made to the new body from the confiscated estates of royalists. Rev. Dr. John Ewing (1732-1806), a graduate of Princeton College and the pastor of the First Presbyterian Church of Philadelphia, was then made provost, and David Rittenhouse, the astronomer, was vice-provost. In 1789, when the Federal Constitution was adopted and a new government firmly established, the friends of Dr. Smith procured the reversal of the former act of the Legislature and the reinstatement of the college trustees. In 1791, by an act of the Legislature, the two bodies were united in one under the present title. Dr. John Ewing remained provost until his death in 1806.

The subsequent provosts have been as follows: Rev. John McDowell, D. D., appointed 1806; Rev. John Andrews, D. D., 1810; Rev. Frederick Beasley, D. D., 1813; Rev. W. H. De Lancey, D. D. (afterwards bishop), 1828; Rev. John Ludlow, D. D., 1834; Henry Vethake, LL.D., 1853; Rev. Daniel R. Goodwin, D. D., 1860; Charles J. Stille, LL.D., 1868; William Pepper, M. D., LL.D., 1881.

In 1828 two large and commodious buildings were erected on Ninth street below Market, one for the Department of Arts, the other for the Department of Medicine. These continued to be used until 1872, when the site was sold to the U. S. government for the erection of a post-office. The Law School, which had been organized in 1789, and other associated departments, were also accommodated in the Arts building. In the course of time the fame and growth of the Medical Department had greatly surpassed those of the Department of Arts. Although the successive provosts and professors were men of culture and

acknowledged ability, their labors were confined to a narrow field and a traditional curriculum. Even the city of Philadelphia, from which alone the students in general came, sent as many more of her youth to other colleges for a liberal education. Dr. Charles J. Stille, who became professor of English literature in 1866, began at once an active effort for the improvement and enlargement of the University. A year later he was made provost and his ability to effect changes was greatly increased. He succeeded in stimulating the liberality and civic pride of wealthy citizens of Philadelphia. He also enlisted the aid of the authorities of the city and State. As a result of his persevering labor the University obtained a tract of more than ten acres in West Philadelphia, on which new and imposing buildings were erected. The main building, in the collegiate Gothic style, has a front of 260 ft. and a depth of 100. It consists of a central building containing the chapel, library, and other rooms, and two wings, the western arranged for the Department of Arts, and the eastern for the Department of Science. This building was publicly inaugurated with appropriate ceremonies Oct. 11, 1872. Dr. Stille had not limited his efforts to providing better accommodations for the work of the University. He had greatly enlarged the instruction in science, as required by the demands of the age, and organized for it a separate faculty. This new department afterwards took the name "The Towne Scientific School," from one of its liberal benefactors.

Under the liberal administration of Dr. Pepper the University has acquired 17 more acres of land and has continued to increase the number of its buildings, courses of study, professors and students. To the College Department has been added the "Wharton School of Finance and Economy," founded by the liberality of Joseph Wharton and designed to give liberal and special training to young men who expect to enter on the management of large business. There have also been added three new faculties—the Veterinary, the Biological and the Philosophical, and in connection with these appropriate buildings—the Veterinary Hall and Hospital and Biological Hall. There have also been erected a Nurses' Home and Maternity Hospital. To the course in music and many of the lectures in other courses women are admitted. The instruction in the law department is now given in the central part of the city, where it is expected that a special building for this purpose will be erected. An Alumni Hall on the University grounds is also projected.

The public-spirited citizens who had taken part in the founding of the college made it valuable donations of books as the nucleus of a library. Unfortunately, owing to various causes, this important adjunct to liberal training was neglected. Few additions were made to the stock of books until the University was removed to West Philadelphia. On entering its new buildings the University received from the family of Stephen Colwell a valuable collection of books on political economy; the library of Prof. George Allen, rich in classics, bibliography, Shakespeare and the art of war. Other additions were made at various times, and in October, 1888, was laid the corner-stone of a Library Building, which will furnish accommodation for 500,000 books. The valuable philological library of Prof. F. A. Pott (*q. v.*) was purchased for the University by some alumni. The law library of Hon. Benjamin H. Brewster, U. S. attorney-general, was presented in the name of George Biddle. The total number of volumes in the library is about 55,000.

As already mentioned, the Medical School was projected in 1765. Dr. John Morgan, a pupil of Hunter and Cullen, filled in it the first medical professorship created in America. The school was organized in 1767 with Dr. Morgan as professor of the theory and practice of physic, and Dr. William Shippen as professor of anatomy and surgery. Able professors, including Dr. Benjamin Rush, were added within a few

years. Other professors of national reputation have succeeded to this faculty at various times. The first commencement at which medical degrees were conferred in America was held here in June, 1768. Since that time over 10,000 graduates have received diplomas whose worth has been acknowledged in all parts of the world. One unpleasant result of this wide reputation was the attempt of unprincipled men to sell diplomas pretended to be issued by its authority. The fraud was soon discovered, but to uproot it required the effort of years. Finally the chief offender was convicted and imprisoned and the Legislature of Pennsylvania formally annulled the simulated charters. In 1864 an auxiliary department of medicine was instituted through the liberality of Dr. George B. Wood, one of the distinguished professors. Its course is essentially post-graduate, and is intended to give instruction in collateral branches of science as needed for the thorough education of a physician. The Medical Department has shared in the changes produced by the removal of the University to West Philadelphia and the erection for its use of a commodious building. An excellent hospital and an extensive laboratory have been erected in connection with this department. The course of instruction in medicine here pursued since 1877 is a graded one, extending over four years, though diplomas are granted to those who have successfully completed three years of the course. Advanced students are encouraged to make original researches in the various laboratories. Since the present system was adopted the zeal and general proficiency of the students have increased to a marked extent. (See MEDICAL COLLEGES OF AMERICA.)

The departments of the University fully organized and in operation are those of Arts and Science, Medicine, Law, Dentistry, Philosophy, Biology, and Veterinary Medicine. The University has nine large buildings—the College Hall, Medical Hall, Laboratory, Hospital, Veterinary College and Hospital, Biological Hall, Home for Nurses, Maternity Hospital, Library. Close to the University buildings are the Athletic grounds, which, as well as the gymnasium, furnish facilities for physical education, which is here under the direction of a competent instructor. The Catalogue for 1887-88 shows the total number of professors and instructors to be 152; the number of students in the College Department, 324; in the two Medical Departments, 445; in the Department of Dentistry, 123; in the Department of Veterinary Medicine, 57; in the Department of Biology, 30; in the Department of Law, 159; in the Department of Philosophy, 54; total, 1187. (J. P. L.)

PENOBSCOTS. See **ARENASIS**.

PENSACOLA, a city of Florida, the seat of Escambia co., is on Pensacola Bay, 5 miles from the Gulf of Mexico, and 262 miles E. of New Orleans. It is a terminus of the Louisville, Nashville, and Southern, and the Pensacola and Atlantic Railroads. The latter crosses part of the bay on a pile-bridge 6 miles long. The city has a custom-house, court-house, marine-hospital, 4 hotels, 1 national and 2 other banks, a weekly and a daily newspaper, 10 churches, and 8 schools. There are 2 foundries, and several lumber- and planing-mills. The city has gas- and water-works, and parks averaging 5 acres. Its property is valued at \$3,000,000, its public debt is \$280,000, and the yearly expenses are \$45,000. The city draws 300,000,000 feet of yellow pine from the forests of Alabama, and ships it to all parts of the world. Fishing is an important industry, the pompano, red snapper, and grouper, and other varieties, being abundant in the vicinity.

Pensacola was settled by Spanish colonists before 1700. In 1719 it was captured by Bienville (q. v.), but soon afterwards was restored. The British had possession of West Florida from 1763 to 1781, and during the wars with Napoleon they were allowed to hold Pensacola, and organize expeditions in its harbor. Gen. Andrew Jackson seized the town Nov. 6, 1814,

and the British withdrew, after blowing up the fort. In prosecution of the war with the Seminoles, in 1818, Jackson again invaded Florida, and seized Pensacola, on the plea that the Spanish authorities abetted the Indians in hostility. By the treaty of 1819 Florida became part of the United States.

Pensacola Bay forms an excellent land-locked harbor nearly 8 miles long. The entrance between Santa Rosa Island and the mainland is a mile wide, and is guarded by Forts McRee and Pickens, the latter on the island. The depth of water on the bar is 21 feet, and at the wharves 26 feet. Besides a lighthouse, there are a navy-yard, marine-hospital and barracks, and in the vicinity the villages of Bagdad and Milton. When Florida seceded in January, 1861, the navy-yard was surrendered without resistance to a body of State militia. But Lieut. A. J. Slemmer, who had taken 80 soldiers and marines from Fort Barrancas to the more defensible Fort Pickens, refused to surrender. After fruitless negotiations at Washington, Col. Harvey Brown was sent with 750 men to take command. Other reinforcements were sent, which encamped on the island. After some vain attempts to dislodge them, and some ineffectual artillery practice, Pensacola was evacuated by the Confederates. In February, 1864, a fire destroyed much valuable property. Since the close of the war Pensacola has slowly recovered from its effects. It has occasionally been visited by yellow-fever, and in 1882 this disease is said to have carried off 200 inhabitants. Yet, with proper sanitary regulations, the city can be kept free from this plague, and in other respects its salubrity is unquestioned.

PENSION SYSTEM OF THE UNITED STATES.

A pension is a stated allowance of money to a person by the government in consideration of merit or the nation's gratitude for services rendered—civil, military, or naval; to provide for the casualties of battle, and to encourage enlistments, continued service, and personal bravery in the contingency of war. Pensions are granted either under authority of existing general laws, or by special act of Congress. Prior to 1858 the weight of authority ruled that a pension law was a contract and the pension granted thereunder a debt. This was the view held by Attorney-General Cushing. Since 1858, the Secretaries of the Interior, who have appellate jurisdiction in the decisions of the Commissioner of Pensions, have invariably held that it is a gratuity, and no part of a contract for service rendered; that it is not a vested right; that Congress by legislation can terminate all rights existing under former pension laws; that a pension is a payment for loss of physical disability to earn a livelihood, determined solely by the degree of disability. The question, *per se*, as to whether a pension is a gratuity, has never been decided by the U. S. Supreme Court.

The pension system of the United States differs from that of most other countries in two important particulars: first, pensions, with a very few exceptions, are granted on account of military service only; there is, consequently, no large civil list; secondly, owing to the fact that the United States has no large standing army, but depends in case of war upon temporary levies, its pension legislation has to do chiefly with the volunteers and conscripts of its various wars rather than with regular troops; hence it is that long service, an important element in foreign systems, is not recognized as a basis for pension in this. Military pensions comprise two general classes: *Invalid pensions*, paid to those who in whole or in part are disqualified for the performance of manual labor by reason of wounds or disease contracted in the military or naval service; and *Service pensions*, into which the question of disability incurred by reason of the casualties or incidents of military or naval service does not necessarily enter. Service pensions are usually granted by general acts many years after the termination of the war to which they relate; Revolutionary pensions, thirty-five years

after; War of 1812, fifty-nine years after, and Mexican war, thirty-nine years after.

I. *Historical.*—Within the past quarter of a century the pension system of the United States has developed from an inconsiderable establishment to a great bureau whose operations reach out into nearly every hamlet and township in the Union. Its clientage and disbursements surpass the most extravagant dreams of its founders. It may properly be said to commence with the resolution of Congress dated Aug. 26, 1776, by which the Continental Congress undertook to provide for disabled soldiers of the Revolution. From June 7, 1785, to Sept. 29, 1789, the several States assumed the payment of pensions by a recommendation of Congress on account of its inability to raise money by taxation. After the adoption of the new Constitution Congress resumed their payment by annual enactments, making them payable during the life of the beneficiaries, under the acts of March 23, 1792, and Feb. 28, 1793. By the act of April 10, 1806, pensions to be allowed thereafter were confined to those who had received "known wounds," and extended to the militia and State troops serving against the common enemy. The rate for total disability for an officer was one-half of his monthly pay, not, however, to exceed the pay of a lieutenant-colonel, and for an enlisted man, \$5 per month. Service pensions for the Revolution were allowed under act of March 18, 1818, to indigent survivors at \$20 per month for officers, and \$8 for privates. These benefits were further extended by the acts of May 15, 1828, June 7, 1832, July 4, 1836, and Feb. 3, 1853. Pensions were not provided for the children of Revolutionary soldiers. The first act providing pensions for disabled officers and soldiers of the regular army was passed April 3, 1790, and its provisions were renewed and amended from time to time until they were embodied in the act of March 16, 1802, which is now the fundamental law for pensions on account of disability incurred prior to March 4, 1861. This act provided pensions for widows and children of officers dying in the service of wounds received in actual battle, the rate being one-half monthly pay at date of death. From the date of the passage of this act to March 4, 1861, invalid pension acts in the interests of those serving in the Mexican war and various Indian disturbances and wars, and of the regular army in time of peace, referred directly or indirectly to this act, as containing the principles guiding in their adjudication. Surviving veterans and widows of deceased soldiers of the war of 1812, who served sixty days—it being required of the widows that marriage should have taken place before the close of that war—were allowed service pensions of \$8 per month from Feb. 14, 1871, the date of the passage of the act, upon proof of loyalty during the Rebellion. Soldiers and widows of soldiers of that war are allowed service pensions at \$8 per month without condition as to the date of marriage or loyalty, in case of a service of fourteen days, or in battle, under act of March 9, 1878. Widows' pensions under both these acts have been increased by the act of March 19, 1886, to \$12 per month. The act of Jan. 29, 1887, granted, from the date of the passage of the act, pensions to survivors of the Mexican war, who, being duly enlisted, actually served sixty days with the army or navy of the United States in Mexico, or on the coasts or frontier thereof, or *en route* thereto, in the war with that nation, or were actually engaged in a battle in said war, and were honorably discharged, or who have been personally named in any resolution of Congress for any specific service in said war, and to the surviving widows of such officers and enlisted men: Provided, that such survivors and widows have attained the age of 62 years, or are disabled or dependent owing to some cause recognized by the pension laws as sufficient reason for the allowance of a pension. Pensions under this act are at the same rates as under the preceding acts.

The last two surviving revolutionary soldiers who

were allowed pensions under the general laws were William Hutchings, of Hancock co., Me., who died May 3, 1866, aged 102 years, and Samuel Downing, of Saratoga co., N. Y., who died Feb. 18, 1867, aged 101 years. The following revolutionary soldiers were granted pensions by special act, dated Feb. 22, 1857: John Gray, Noble co., Ohio, who died March 28, 1869, aged 105 years, and Daniel F. Bakeman, of Cataraugus co., N. Y., who died April 5, 1869, aged 109 years. On June 30, 1888, there were 37 persons drawing pensions as the widows of soldiers of the Revolutionary war. Within the past year the names of Nancy Buntin, widow of William Buntin, of Tennessee, and aged 84 years; Mary Casey, widow of John Casey, of Ohio, aged 88 years; and Freelove Barnes, widow of Jonathan Seeley, of Michigan, aged 92 years, have been added to this roll.

The number of pensions granted under all laws to soldiers of the Revolution and their widows is 62,069; war of 1812, 60,670, amounting to \$36,310,256.04; Mexican war, 21,724. By the act of March 2, 1833, the administration of the pension system was raised to the dignity of an independent bureau, under the management of a Commissioner of Pensions. Prior to this time the pension laws had been administered under the direction of the Secretary of War, except those which related to naval pensions, which were under the administration of the Secretary of the Navy, and the laws granting bounty lands, which were administered under the direction of the Secretary of the Treasury. Both these branches were subsequently transferred to the pension office, the former, March 4, 1840, and the latter, Jan. 20, 1843. On March 3, 1849, the pension office became a bureau of the newly created Department of the Interior. As at present organized its affairs are administered by a commissioner, under whose charge come all matters relating to pensions, and who is appointed by the President, by and with the advice and consent of the Senate, two deputy commissioners, a chief clerk, an assistant chief clerk, a law or appeal clerk, a board of legal reviewers, a board of medical reviewers, special examiners, examiners' clerks, copyists, messengers, laborers, and watchmen, in all a force of 1554 persons, directly engaged in the settlement of claims for pensions. In addition to these there are at various points throughout the country 2515 surgeons, whose duty it is to examine all applicants for invalid pension who may be ordered before them, and report to the Commissioner of Pensions as to the degree of the applicant's physical disability. This makes over 4000 persons under the management and direction of the Commissioner of Pensions. In addition to this there are 18 Pension Agents for the payment of pensions, conveniently located throughout the country, under his direction, and who are also appointed by the President by and with the advice and consent of the Senate. The salaries and expenses of this large force amounted in the aggregate to \$3,262,524.67 for the fiscal year ending June 30, 1888.

II. *Statistics.*—The following statement shows the remarkable growth of the U. S. pension system from its humble beginning: The total amount expended by the Bureau of Pensions for all purposes during the fiscal year ending June 30, 1888, was \$82,038,386.59, being 21½ per cent. of the total (estimated) gross income—\$380,000,000; and 31 per cent. of the entire expenditures—\$267,924,801.13—of the U. S. government for the same period; about 65 per cent. of the cost of the entire military establishment of France, 80 per cent. of that of England, 90 per cent. of Germany's, and \$30,730,784.59 more than that of Austria-Hungary. During the same fiscal year \$1,439,530.10 were paid as fees to attorneys alone. From 1861 to 1888 inclusive, 1,166,926 claims for pension have been filed, 737,200 have been allowed, and \$963,086,444.73 have been disbursed on account of pensions.

At the close of the fiscal year ending June 30, 1888,

there were 452,557 pensioners upon the rolls, classified as follows: 323,020 late war army invalids; 90,845 late war army widows, minor children, and dependent relatives; 3815 late war navy invalids; 2083 late war navy widows; 806 survivors of the war of 1812, and 10,787 widows of those who served in that war; 16,060 survivors of the war with Mexico, and 5104 widows of those who served therein. During the same year there were received 2,697,608 pieces of mail matter, and 2,041,482 were sent out. The highest rate of pension issued during the year was \$2000 per annum; the lowest now being granted is \$24. The annual average value of a pension for the same year is \$125.30. The average age of pensioners, 67 years; average length of service for which pensions are granted on account of the war of 1861-65 is two years. The highest rate of pension paid under the general law is \$72. Allowances by special acts of Congress range from \$10 to \$416.66 per month. Up to June 30, 1888, three persons were receiving \$5000, four were receiving \$2000, and five were receiving \$1200 per annum under special acts of Congress; 1053 were receiving \$72 per month. From 1861 to 1865 President Lincoln approved 41 special pension acts; from 1865 to 1869, President Johnson, 431; from 1869 to 1877, President Grant, 490; from 1877 to 1881, President Hayes, 303; from 1881 to 1885, Presidents Garfield and Arthur, 736; from 1885 to 1888, President Cleveland, 1577, making a total of 3578. On June 30, 1888, there were 2363 pensioners, receiving \$367,976 annually, who resided in foreign countries; 1004 in Canada, 38 in France, 375 in Germany, 527 in Great Britain, 58 in Switzerland, and the remainder throughout Europe, Asia, Africa, and Australasia.

III. *Who are entitled to Pension?*—1. All officers of the army, including regulars, volunteers, and militia, officers of the navy and marine corps, and all enlisted men however employed in the military or naval service who have been disabled by reason of wounds or injuries received or disease contracted in the service of the United States and in the line of duty. These constitute the class known as "invalid pensioners."

2. The widows, or minor children under sixteen years of age, of all officers and enlisted men of the army or navy who have died of wounds or injuries received or disease contracted in the service and line of duty. The widow of a soldier who died of disease contracted in the military service prior to March 4, 1861, is not entitled to pension unless the cause of death originated in some war; and the widow of an officer or enlisted man in the navy who died of disease originating prior to March 4, 1861, is not entitled unless he died in the service.

3. The dependent mothers, fathers, or minor brothers and sisters of such officers and enlisted men who died of injuries or disease originating as above stated, and left no widows or minor children surviving. Dependent relatives are entitled in the order in which they are named. Upon the death of the mother the father becomes entitled, and upon the death of the father the minor brothers and sisters (jointly). They must have been dependent upon the soldier for support, in whole or in part, at the date of his death, otherwise there is no title.

4. The several classes above mentioned who are entitled to service pension under the various acts of Congress for services rendered in the Revolutionary war, war of 1812, and Mexican war.

IV. *Rates and Duration of Pensions.*—The original rate of a pension was half the monthly pay the beneficiary had received as an officer or an enlisted man. In 1816 the "total pension" for privates was increased to \$8 per month, and this rate, although in many cases grossly disproportionate to the degree of disability, was the highest that could be allowed to persons under the rank of commissioned officers until about the close of the civil war. The "total" rate for second lieutenant was \$15; first lieutenant, \$17; cap-

tains, \$20; majors, \$25; and lieutenant-colonels and all officers of higher rank, \$30. Like rates were fixed for naval officers of the same relative rank. Fractional ratings were given for lesser degrees of disability. In 1866 Congress created three grades above that of "total pension," and the pension for all these grades has since been increased. What is known as the first grade includes cases of permanent disability in a degree requiring the regular aid and attendance of another person, and entitles the beneficiary to \$50 per month. On June 16, 1880, an act was passed increasing the pension of all who were then on the roll at \$50 to \$72. By a liberal interpretation this has been held to include those who were then entitled to \$50; but those who have become entitled to a first grade pension since that date receive only \$50. The second grade includes cases of permanent incapacity for the performance of any manual labor, for which the pension is \$30 per month. The third grade is for a disability equivalent to the loss of a hand or foot, the rate being \$24 per month.

For disabilities below these three grades the rates range from \$2 to \$18 per month for privates, non-commissioned officers and lieutenants, the maximum in the cases of officers above the rank of lieutenant being the old "total of rank." There is also a class of "permanent specific" disabilities, for which the rates are fixed by law, such as the loss of both feet, both hands, or both eyes, for which the pension is \$72 per month. For amputation at the shoulder or hip joint, or so near the joint as to prevent the use of an artificial limb, \$45 per month is paid; for total disability of an arm or leg, loss of one hand and one foot, or total disability in the same, or amputation at or above the knee, \$36; for the loss of a hand or foot or total disability in the same, or for total deafness, \$30 per month.

Widows of privates receive \$12 per month, and \$2 additional for each child of the soldier, and when no widow survives minor children receive their pension jointly; dependent relatives receive \$12 per month; widows and dependent relatives of commissioned officers receive the "total of rank." The pension of a survivor of the war of 1812 or of the Mexican war is \$8 per month. Pensions on account of disability or death from causes originating prior to the beginning of the civil war commence from the date of discharge or death of the soldier, if the application was made within three years of the time the right of pension accrued, otherwise from the date of completing the proof. Pension on account of disability from causes occurring since the beginning of the civil war begin from the date of discharge or death of the person having prior right to pension, provided application was made before July 1, 1880; otherwise from the date of filing application, except in the case of widows, whose pensions begin from the time of the soldier's death without regard to the date of application. Widows' pensions are generally granted for life, but pensions to minor children, brothers and sisters terminate when they attain the age of sixteen years, or, in the case of sisters, when they marry. Widows' pensions end when they remarry. The open and notorious adulterous cohabitation of a widow operates to terminate her pension, and an invalid pension may be withdrawn if it be shown that the disability has ceased.

V. *How Pensions are Allowed and Paid.*—The great majority of claims are adjudicated upon *ex parte* testimony filed by the claimants, or their attorneys, but if doubt or suspicion arise in regard to the merits of any claim the papers may be referred to a special pension examiner, who will proceed to take testimony in the neighborhood where the claimant resides, or in such other places as may be necessary, and report the facts to the Commissioner of Pensions. Pensions are paid every three months through 18 U. S. Pension Agencies referred to above. At each of these agencies a permanent roll is kept of all pensioners residing within its limits, showing the class, sex, rates of pension and

PENSION SYSTEM.

Table of United States Pensions and Pensioners

Fiscal year ending June 30—	Army.		Navy.		Army and Navy.		War of 1812.			Total number of applications filed.	Total number of claims allowed.	Number of pensioners on the roll.			Disbursements.	
	Applications filed.	Invalids, etc.	Applications filed.	Invalids, etc.	Claims allowed.	Invalids, etc.	Applications filed.	Survivors.	Widows.			Applications filed.	Survivors.	Widows.		Invalids.
1861.....	1,362	1,000	60	65	413	49	2,487	4,337	4,299	8,636	\$1,072,461.55	
1862.....	28,380	22,377	290	285	3,763	49,332	462	4,341	3,818	8,159	790,384.76	
1863.....	20,263	32,627	365	324	17,041	22,446	63,599	7,884	7,821	6,970	14,791	1,025,139.91	
1864.....	27,299	44,464	455	466	15,212	24,939	72,684	39,487	23,479	27,656	51,135	4,504,616.92	
1865.....	35,799	28,732	350	375	22,883	27,294	65,256	40,171	35,880	50,106	85,986	8,525,153.11	
1866.....	15,905	20,265	250	333	16,589	19,893	36,753	50,177	55,632	71,070	126,722	13,459,996.43	
1867.....	7,292	13,099	170	207	9,160	19,461	20,768	36,482	60,565	83,618	153,183	18,619,926.46	
1868.....	11,035	14,496	290	245	7,292	15,904	26,066	28,921	75,957	93,688	169,643	24,010,881.99	
1869.....	12,991	11,400	260	200	5,721	12,500	24,851	18,221	87,521	111,165	198,686	28,422,884.08	
1870.....	8,837	8,985	190	142	7,934	8,399	43,969	16,562	93,394	114,101	207,495	27,780,811.81	
1871.....	8,857	6,755	240	178	6,468	7,244	20,741	5,074	198	31	43,969	16,562	93,394	114,101	207,495	33,077,383.63
1872.....	6,427	6,427	248	120	4,073	4,073	6,546	3,815	17,504	3117	26,391	113,924	118,275	232,429	30,169,341.00	
1873.....	5,603	5,284	228	151	5,937	3,152	1,481	1,299	3,186	2,242	18,303	119,500	118,911	238,411	29,185,289.62	
1874.....	11,926	5,264	310	178	5,760	4,736	737	713	563	810	16,704	121,628	114,613	236,241	30,593,749.56	
1875.....	17,030	5,264	344	130	5,360	4,376	425	571	240	416	18,704	122,989	111,832	234,821	29,653,116.63	
1876.....	16,532	5,269	271	97	7,282	3,861	188	348	57	168	23,628	124,239	107,898	232,137	28,351,599.69	
1877.....	18,812	6,561	300	131	7,414	3,550	2,786	15,897	817	126	22,715	128,723	103,381	232,104	28,580,157.04	
1878.....	36,835	9,767	599	215	7,242	3,379	8,891	8,891	817	181	44,587	131,649	92,349	242,755	26,844,415.18	
1879.....	18,832	25,692	1,361	559	10,176	4,455	2,976	2,976	284	18,177	18,177	138,615	104,140	242,755	33,740,526.19	
1880.....	110,673	18,455	1,361	515	21,394	3,920	1,285	1,285	115	4,630	14,146	145,410	105,392	250,802	57,240,540.14	
1881.....	29,004	10,349	472	211	22,946	3,999	85	818	26	693	31,116	164,110	104,720	208,830	50,626,538.51	
1882.....	35,039	11,878	777	251	32,014	6,366	61	770	23	882	48,776	182,633	103,064	208,830	54,296,280.54	
1883.....	28,962	11,289	671	244	27,414	6,366	52	567	24	388	48,776	182,633	103,064	208,830	60,431,972.85	
1884.....	27,959	11,557	725	265	27,580	7,743	27	373	18	426	40,918	169,470	97,286	323,756	67,273,536.74	
1885.....	35,202	13,238	862	265	31,937	7,743	24	373	18	426	40,918	169,470	97,286	323,756	65,083,706.72	
1886.....	36,484	15,759	836	338	35,283	11,217	24	304	5	305	49,893	170,346	97,979	345,125	64,584,270.45	
1887.....	18,444	15,759	836	338	35,283	11,217	24	304	5	305	49,893	170,346	97,979	345,125	74,815,466.85	
1888.....	18,444	15,759	836	338	35,283	11,217	24	304	5	305	49,893	170,346	97,979	345,125	79,646,146.37	
Total.....	664,468	377,128	12,710	6,639	403,267	251,478	34,737	44,673	25,691	34,979	1,166,926	737,300	343,701	453,657	963,086,444.73	

In the total number of Applications filed in 1888 are included 6045 survivors and 2808 widows of the war with Mexico. In the total number of claims allowed in 1888 are included 9048 survivors and 4201 widows of war with Mexico. In the number of pensioners on the roll under the head of "Invalids" and "Widows," etc., are included survivors and widows of the war of 1812, respectively, commencing with the year 1871, and survivors and widows of the war with Mexico, commencing with the year 1877.

post-office address of each. Those who live in the city where an agency is located, or in its vicinity, generally appear in person at the office of the Pension Agent on the quarterly pay-day, and receive a draft on the U. S. Treasury; to others a like draft is forwarded by mail. A form of affidavit or voucher must be executed by the pensioner before a magistrate, which with his pension certificate must be exhibited to the Pension Agent before payment is made. The largest number of payments at any one agency is that of Columbus, Ohio, where 44,405 pensioners are paid. The largest number of pensioners in any one State is that of New York, where 45,219 reside, to whom are paid \$5,486,019.84 annually.

PENTATEUCH AND JOSHUA. The article on this subject in the *ENCYCLOPÆDIA BRITANNICA* is essentially a presentation of one out of several controverted views. In the present state of Pentateuchal discussion this is not a severe criticism, but is merely a statement of a fact which largely determines the form of the present supplementary article.

It would be generally agreed, no doubt, that the Hexateuch is essentially a literary unity. One scholar might claim that this unity arises from the fact that Moses personally wrote the Pentateuch, while some one in sympathy with him supplemented his work by writing the Book of Joshua; and another might claim that it arises from the Hexateuch having been put together, partly from older documents, by a scribe or succession of scribes who lived a thousand years after Moses; and others might make still different claims; but as to the unity itself there would be no difference of opinion. It is a single work, with a single purpose, every part of it bending to that purpose, no matter how it came to be so. It would also be agreed that the unity of this work is not that of strictly continuous composition in one vein. It has a great variety of contents. It is a prose work, but includes a considerable number of poems, *e. g.* Gen. xlix.; Ex. xv.; Num. xxiii., xxiv.; Deut. xxxii. 1-43; Deut. xxxiii. It also includes several formal orations, or addresses, *e. g.* Deut. i. 3-iv. 40; Josh. xxiii.; Josh. xxiv., etc. It further contains a large body of legislation of the greatest possible variety of form and scope. In Ex. xxi.-xxiii., in connection with Ex. xx. and xxxiv. 10-26, is a compact, codified list of precepts, largely in the apparent form of decisions on adjudicated cases, in shape to be easily memorized, and suited to practical judicial use. Again, in Deuteronomy there is a more extensive collection of laws, with a bulky historical-homiletical comment on them. These two codes are designed for magistrates and people of all classes. Besides these, and of considerably larger bulk, is an additional collection of laws, scattered through the different books, and designed especially for the information of the priestly class. This legislation consists partly in records of precedents, partly in manuals for particular services, partly in alleged proclamations, general orders, return-reports, and the like. While certain portions of it are very carefully arranged in order, this class of the legislation as a whole exhibits no trace of orderly arrangement or of codification. These various poems, addresses, laws, heterogeneous as they are in themselves, are bound together, partly by being arranged in a certain order, but mainly by being imbedded in a connecting narrative. The narrative itself, moreover, is frequently duplicated, and this and other phenomena are supposed to indicate that previously existing narratives have been incorporated into it.

These facts as to the contents of the Hexateuch throw light upon the nature of the literary processes by which it was produced. One who holds that Moses wrote the Pentateuch in substantially its present form should also hold that Moses first accumulated a mass of materials in the shape of poems, addresses, laws in various forms, narratives, and afterward wove these

together, adding whatever was needful for the purpose. One who holds that the book is divinely inspired should also hold that the method just mentioned was the method through which divine inspiration operated in this case. And those who do not hold to the Mosaic authorship, or to divine inspiration, should yet hold that these previously existing materials, in some shape, were a fact, and that they were somehow put together to form the present unity known as the Hexateuch. Further, no one probably would dispute that the different parts of the Hexateuch present differences of literary style, vocabulary, local and temporary point of view, and the like, as decided as the difference in the contents of these different parts.

Such, in outline, are the phenomena indisputably presented. The views now current may of course be generically classified as two: the views of those who hold that Moses is the author of the Pentateuch, and the views of those who deny this. Of those who deny the Mosaic authorship some reject, in the main, the external testimony in the case, including that of the Old and New Testaments, as unhistorical, and deny that the distinctively Israelitish legislation is properly of Mosaic origin; while others affirm the historicity of the Scriptures and the genuine Mosaic origin of the law. Again, the present generation of the scholars who deny that Moses wrote the Pentateuch are pretty well agreed (though not unanimous) in the opinion that the legislative portion of Deuteronomy was written about the time of the great reformation under King Josiah. As to the dates of most of the other parts they disagree greatly. In particular, one school of them (that represented in the *ENCYCLOPÆDIA BRITANNICA*) hold that the priestly legislation is later than Deuteronomy, dating from the times of Ezra and later; while another school, formerly very prominent, and now again coming to the front, hold that the priestly legislation is earlier than the Deuteronomic.

Those who hold that Moses wrote the Pentateuch may be classed in three groups. The first group hold to a mechanical theory of Mosaic authorship; Moses wrote the Pentateuch by dictation from God, or in some such way, so that he may as well have written the account of his own death as any other part of it. Probably it would now be difficult to find scholars who deliberately teach this; the place where it mainly crops out is in the assumptions made by certain men, notably by certain newspaper controversialists when they attack men whom they suspect of heresy. The second group hold to what may fairly be called the traditional view of the Mosaic authorship, namely, that Moses personally wrote the five books, but that the post-Mosaic elements in them were added by later hands, at some unknown period or periods. This view at first sight seems simple and satisfactory, each person who holds it admitting the existence of a very few passages that contain elements later than Moses. But while some make one concession and some another, the number of conceded instances on this theory of irresponsible or at least anonymous tampering with the Mosaic text becomes quite appalling. The third group hold what we may fairly call the modified view of the Mosaic authorship. For my own part, I should state this view thus: Moses is the author of the Pentateuch, and Moses and Joshua the authors of the Hexateuch, in the sense of being responsible for the literary existence of these books in their present form. But they may have been, and most likely were, the authors of them in the way in which one would naturally expect public leaders, such as they, to be the authors of such writings as these. That is to say, they are likely to have written some parts personally, to have written some parts through amanuenses, to have caused other parts to be written by directing secretaries to write them, or by accepting documents prepared to their hand, to have taken other parts from the works of earlier authors. In such a case, the question whether they themselves gathered the writings into their present

form or left that for their successors to do is an open question until it is settled by evidence. Their claim to authorship would not be in the least impaired if it could be shown that the writings were collected into a whole, and parts of them written, by men of the generation that had been associated with Moses and Joshua, and had survived them. Whether their claim to authorship would be impaired on some theory that dated the collection of the writings yet later would depend somewhat on the details of the theory. This last question, however, it is hardly worth while to discuss, unless upon inquiry other views are found to be untenable.

The following proposition would perhaps be accepted in common by all advocates of the Mosaic authorship of the Pentateuch, though many of them would regard it as stating only a part of the truth: The Hexateuchal writings were produced in part by Moses and Joshua, and in part by other men under their influence, and were substantially completed within the lifetime of men who were associated with Moses and Joshua in public affairs. In opposition to this, living scholars who deny the Mosaic authorship of the Pentateuch generally hold that the legislation of Deuteronomy was written in the times of King Josiah, and the other parts of the Hexateuch, some earlier and some later than this. These two propositions are not exhaustive of the question; but, if we examine the evidence bearing upon them, we shall not merely argue the question they present, but shall touch most of the points of interest that properly belong to this supplementary article.

I. The Direct Testimony, and the Reasons Alleged Against it.—To begin with, the direct testimony in the case is very abundant, and no one disputes that it is altogether to the effect that Moses is the author of the Pentateuch. The Rabbinical writings, Josephus, Philo, the Alexandrian Jewish literature, the Apocrypha, are explicit on this point, and often full in details; they betray hardly any difference of opinion, except as to whether Moses wrote the account of his own death, as well as the rest of the Pentateuch. The books of the Old and New Testaments are equally full, though somewhat less explicit. There is no room to exhibit this testimony here, and no need to do so. One line of it can be readily examined by looking up in the Concordances of the Bible and in the indexes of the other books what is said concerning "the book," "the law," "Moses." A moderately full presentation of the Biblical direct testimony may be found in such works as those of Stebbins, Harman (see titles in *Literature at end*), or *Essays on Pentateuchal Criticism*, Nos. v., vi., vii., viii., xi. A considerable number of the passages are cited in the article BIBLE, in this work.

The Biblical testimony in this matter differs from that of the Jewish and Christian tradition outside the Bible, in that it never speaks of the Mosaic books as being five in number, and, except in the Hexateuch itself, mentions no details as to the writing of the books by Moses. But the books of the New Testament and the later books of the Old Testament so cite and refer to the Pentateuchal writings as to leave no doubt that these are the writings with which they connect the name of Moses. Further, they do not confine themselves to such mention of Moses as might merely indicate that he is the most prominent person of the times described in the writings; they explicitly attribute authorship to him: "Him of whom Moses . . . did write" (John i. 45), "For he wrote of me" (John v. 46), "For the hardness of your heart he wrote" (Mark x. 5), "If ye believe not his writings" (John v. 47), "The book of the law of the Lord by the hand of Moses" (2 Chron. xxxiv. 14), and very many similar passages. In Deuteronomy Moses is said to have written what is there called "the book of the law," xxxi. 9-13, 24-27. Many details are given as to the use to be made of this book of the law, and the

use actually made of it by Joshua (Josh. i. 7, 8, xxii. 5, viii. 34, 35, Deut. xvii. 18, 19). We are told that Joshua wrote in it, long after the death of Moses (Josh. xxiv. 25-28). There are mentioned a long list of items of sacred writing, by Moses or by Moses and Joshua, either in this book of the law, or additional to it, but in either case constituting a part of the present contents of the Hexateuch (Deut. xxxii. 44, etc., xxvii. 2-8, xxviii. 58-61, 69 [xxix. 1], xxix. 19, 20 [20, 21], xxx. 10, Num. xxxiii. 1-3, Ex. xxiv. 3-8, xxxiv. 27, xvii. 14, etc.). It is doubtless true that the phrase "book of the law" in these passages is not equivalent in meaning to the word Pentateuch; in some cases it indicates a short section only, and in at least one instance (Josh. xxiv. 26) it includes post-Mosaic writing done by Joshua; but the testimony is distinct to the fact of the production by Moses and Joshua of a large body of sacred literature, mostly identifiable with the contents of our present Hexateuch. This fact must be allowed to interpret what is said in the other books. Taken at its face value, we seem to have here nothing less than a continuous line of testimony from the times of Moses down.

Whether the fact thus testified to is really something less than that Moses wrote the Pentateuch, we will consider presently. It is at least beyond dispute that the testimony, as it stands, represents the written law of Moses, specifically including the Deuteronomic legislation, as in existence for centuries before Josiah, and in this flatly contradicts the main proposition of the critics who deny the Mosaic authorship. See for instance 2 Kings xiv. 6, cf. Deut. xxiv. 16. See also 1 Kings ii. 3, cf. Deut. xxix. 9; 1 Kings viii. 53, 56, 57, cf. Deut. *passim*; 1 Kings viii. 9, cf. Deut. x. 2, 5, and many like instances.

If this evidence will stand, it is by itself sufficient and decisive. Those who regard it as indecisive use mainly four arguments against it. First, they deny that the testimony means all that it is claimed to mean. Secondly, they claim that the texts which contain it are mixed and corrupt, so that they must first be sifted, often to the extent of entire reconstruction, before we accept their evidence. Thirdly, they say that the testimony in its present form, and largely in its more original forms, is the work of men who lived long after the alleged events, who failed to distinguish between stories and facts, who did not sift the information that came to them, who were deficient in the so-called historic sense, and were incorrect observers and reporters of events; and that the testimony must therefore be regarded as largely unhistorical. Fourthly, they say of the claims made in the Hexateuch itself, and of the parts of the testimony that stand or fall with these, that they are intentionally fictional—not necessarily untruthful, but a legal fiction devised for a purpose, and to be interpreted accordingly. These arguments, it will be observed, are capable of being so pushed as to antagonize one another. The men who use them use them in very unlike proportions, and in a spirit ranging from that of reverent devoutness to the extreme opposite.

1. There can be no doubt that the first of these arguments represents a logical process that is some times of great value. It is very often true that a statement does not mean all that we understand it to mean. Dr. Francis Brown has shown (*Journal of the Society of Biblical Literature and Exegesis*, 1882, p. 95) that the testimony of the New Testament to the authorship of the various books of the Old Testament do not go as far as many imagine, and that many passages commonly held to be explicit testimonies to authorship might possibly be otherwise understood, provided there be sufficient reasons against the common understanding of them. This process of minimizing the meaning of statements, to prevent conflict, is legitimate, in its own proper use. Nevertheless, the true law of evidence is that statements are to be understood in their natural meaning, except as de-

cisive reasons compel us to understand them as having less than their natural meaning. There is no dispute that the testimony in the case in hand, in the meaning it naturally conveys, attributes the responsible literary authorship of the Pentateuch to Moses. It is true that most of the statements in the Bible might possibly be understood to mean something less than this, provided there were sufficient proof that this cannot be their true meaning. But this possibility amounts to nothing unless such sufficient proof is forthcoming. This argument is entirely dependent on the question: What positive evidence is there that Moses is not the responsible author of the Pentateuch?

2. The argument from alleged mixture and corruption of texts mainly applies to the pre-exilic books of the Old Testament. In several of the more prominent of these books, they call upon us to accept the alleged fact that the book has been formed by piecing together writings that really belong centuries apart; they allege that we must first dissect the composite work into its original parts, before we take its testimony to matters of fact. In the process of dissection, as they perform it, most of the testimony to writings by Moses is assigned to the later documents that entered into the composite works, and is therefore regarded as untrustworthy. But there yet remain in the earlier documents and in other pre-exilic writings a considerable number of passages that testify to sacred literature written by Moses; these they dispose of by regarding them as interpolations—corruptions of the text. In other words, before we are permitted to take the testimony of these books to the matters of fact under consideration, we are expected to admit that the larger part of the literary work commonly assigned to Isaiah, Jeremiah, and the other later pre-exilic prophets, and substantially all that commonly assigned to the earlier men, Solomon, David, Nathan, Samuel, Joshua, Moses, for example, was written, not by these men, but by unknown scribes, obscure men, who made no mark on their own generation, and left no name to the generations that followed. Views like these are not credible, except upon strong evidence. That some one work should have the text-characteristics just mentioned would not be surprising, but it is difficult to believe that nearly the whole of a nation's literature is marked by these characteristics; it is easier to believe that almost any supposed criteria of composite structure are mistaken. It is not surprising if we find that some great man did not perform work that has been commonly attributed to him; or if we find that some obscure man has done great work; but when we are called upon to believe that throughout a nation's history the great men have done substantially nothing, and the nobodies have done everything, that is beyond the bounds of ordinary credibility. That these texts have been thus mixed and corrupted, to the extent and in the way required by the argument, is on the face of it very unlikely, and is not to be admitted except upon cogent evidence. And if the mixture and corruption of the text were admitted or proved, that would not prove that Moses is not the author of the Pentateuch; it would simply diminish the amount of the evidence of his being the author. The testimonies to his authorship would remain in existence, and would continue to have the character of a respectable tradition, and the question would still be: What positive evidence is there against this?

3. The same principles cover the argument from the alleged lack of historicity in the writings that contain the testimony. It is alleged that the testimony dates several centuries after the events, that it is not contemporary testimony, and is on that account of less value. The allegation depends entirely on the question of text-distribution which we have just considered. If we take the text as it stands, without rearranging it, the testimony begins in the time of Moses himself, and is continuous from that date. It is further urged that in the later times, and particularly in the times of

the New Testament, the witnesses may have thought of the Mosaic authorship as a matter of practical instruction and of received dogma, rather than of historical fact; but admitting this, it remains to be proved that they did not also regard it as a historical fact. Further, it is urged, especially in regard to the Old Testament narratives, that these, by their contradictions, by the nature of many of the statements they make, and by other marks, show themselves to be unhistorical. The principal alleged marks of this sort we will consider presently, in another connection. For the moment we content ourselves with noticing that the alleged unhistoricity of the testimony is not to be accepted without sufficient proof, and that it will take very cogent proof to be sufficient, and secondly, that if the proof were forthcoming, that would have no direct weight to show that Moses is not the author of the Pentateuch; it would only weaken the evidence of his being its author. The question would still be: What proof is there that he was not so?

4. The principles in hand still cover the argument from alleged unhistoricity, when the argument assumes the form of the fictional hypothesis. On the face of it there is no absurdity in supposing that Jewish statesmen of the times of Josiah and later might have given the literary form of a Mosaic tradition to laws codified by themselves. It is possible that such a fiction is morally defensible, and it is supposable that they might have done the thing, even if it were morally wrong. But if this fictional hypothesis be resorted to at all, it must be applied not to the testimony in the Hexateuch alone, but to much of that in the other books, both the pre-exilic and the post-exilic. If this fictional mode of describing the laws of Israel existed, it existed as consciously fictional for several centuries, covering several national revolutions, and we have a pretty abundant literature for those centuries. The absence of any distinct mention of it in that literature, as well as the difficulty of the thing itself, shows it to be quite improbable that it ever existed. In the circumstances, if the fictional hypothesis be affirmed, purely on the ground of its being necessary in order to explain the circumstance that Moses did not write the Pentateuch, that circumstance needs first to be established by sufficient proofs. Unless the proofs are forthcoming, the hypothesis amounts to absolutely nothing.

The difficulty of establishing the charge of lack of historical credibility, as against the testimony of the Old Testament, has of late years greatly increased. The outcome of recent excavations and explorations is altogether against it. As long as these books contained, in the main, the only known accounts of the events they mention, there was some plausibility in the theory that perhaps these accounts were written rather to teach moral lessons than to preserve an exact knowledge of events. It was easy to say that in those times men had not the historic sense. But the recent discoveries touch the events recorded in the Bible at very many different points, in many different generations, mentioning the same persons, countries, peoples, events that are mentioned in the Bible, and showing beyond question that these were strictly historic. The point is not that the discoveries confirm the correctness of the Biblical statements, though that is commonly the case, but that the discoveries show that the peoples of those ages had the historic sense, and specifically, that the Biblical narratives they touch are narratives of actual occurrences.

It is also a familiar and acknowledged fact that the general contents of the Hexateuch and most of the phenomena it presents agree with the account of its origin as given in the testimony, and thus confirm that account. There is no room here for details under this statement, though some instances will presently be given.

II. *Alleged Proofs of the Late Origin of the Hexateuch.*—By universal admission, then, we have an ac-

count of the origin of the Hexateuch, given by witnesses who seem to be trustworthy, and confirmed by a great body of testimonies and circumstances, with no testimony whatever against it. The presumption is that the account is true. This is not a merely technical presumption, but is of the nature of a very strong probability. If any one seeks to overthrow the result thus reached it ought to be not by conjectures, but by impregnable proofs. We turn to see what are the proofs offered in the case.

The critics who deny that Moses wrote the Pentateuch are accustomed to claim much on the ground of the superiority of their scientific methods. On the strength of this superiority of method they claim for themselves largely the authority of experts. They censure their opponents, and sometimes justly, for arguing from the assumed meaning of passages instead of the necessary meaning, for resorting to harmonistic conjectures for the removal of difficulties, and the like. Are their claims to scientific superiority so well based that we must accord to them something on this ground, and accept their opinions as the opinions of experts? To decide this let us examine a few specimens. We will take them just as they occur in the article in the *ENCYCLOPÆDIA BRITANNICA*.

"It was observed that Moses does not speak of himself in the first person, but that some other writer speaks of him in the third—a writer, too, who lived long after." But why should Moses be precluded from speaking of himself in the third person, just as Cæsar and Josephus do? And if it is another writer that speaks of Moses in the third person, he could do this as easily while Moses was living as "long after."

"The expression of Gen. xii. 6, 'the Canaanite was then in the land,' is spoken to readers who had long forgotten that a different nation from Israel had once occupied the Holy Land." Not necessarily. A reader of the times of Moses, or of any other time, might have a curiosity to know with what peoples, if any, Abraham and Jacob came into contact on reaching Palestine.

"Again, the 'Book of the wars of Jehovah' (Num. xxi. 14) cannot possibly be cited by Moses himself, as it contains a record of his own deeds." But there is nothing in the fact that a book mentions a man's deeds to prevent that man's citing the book.

"When Deut. xxxiv. 10 says that 'There arose not a prophet since in Israel like unto Moses,' the writer is necessarily one who looked back to Moses through a long series of later prophets." But this language would be very natural in the mouth of any old man who, in his youth, had known Moses. The inference that the writer must have looked back "through a long series" of prophets to Moses is gratuitous.

Absolutely these instances are representative. At this point any man of sense is competent to test the claims of this alleged scientific method. Whoever will take the trouble to look carefully at the instances of simple use of Biblical passages, in the article in the *BRITANNICA* and in the whole class of writings it represents, will thereafter find himself little disposed to place confidence in this class of writers as experts. No men are more in the habit than they of putting upon statements or upon phenomena the interpretation that will serve their turn, and then arguing as if this were the only possible interpretation.

It is by processes precisely like these that the attempt is made to invalidate the historicity of the Old Testament writings, and thus their testimony in the case in hand. Take a single instance for example. According to Gen. xvi. 16, xxi. 5, Ishmael was fourteen years old when Isaac was born. "But how does this accord with xxi. 9 *seq.*, where Ishmael appears not as a lad of seventeen but as a child at play (כִּצְחָס, v. 9), who is laid on his mother's shoulder (v. 14), and when thrown down by her in her despair (v. 15) is quite unable to help himself? Similar inconsistencies appear, etc." But the statement that Ishmael "made

sport" is not a statement that he was then "a child at play." The narrative does not say that he was laid upon his mother's shoulder. When it is said that she "cast him under one of the shrubs" that does not imply that he was a baby and she had been carrying him. According to the account he was "quite unable to help himself," not by reason of tender age, but by reason of exhaustion. In all this there is no contradiction to what is elsewhere said concerning Ishmael.

It is true that if we are to understand the Biblical narratives as historical we must abandon the baby-story interpretation sometimes given to some of them, and we must interpret them by putting together all the known facts in each case and allowing the facts to limit one another. For the lack of care in these particulars the traditional understanding of the history is in some points open to criticism. Most of the difficulties will vanish if one merely put all the facts together, so as to obtain a complete understanding of the matter concerning which the difficulties arose, and most of the remaining difficulties are of the sort that would doubtless vanish if we knew more about the matter.

There is then nothing in the methods of these men to justify us in accepting their conclusions on the ground of their superior qualifications; all we have to do is to examine the evidence adduced to see what conclusions it justifies.

1. The simplest class of arguments for the late date of the Hexateuch is made up of the instances in which it is alleged that these writings mention or allude to events later than the times of Moses and Joshua. To understand the precise bearing of these instances we need to glance at certain facts connected with another name—that of Phinehas, the grandson of Aaron and grandnephew of Moses. Of Phinehas it is recorded that he was already in public life, and among the most prominent men of the nation, before the death of Moses. See Num. xxv. 7, 11; Ps. cvi. 30; Num. xxxi. 6. Next to Joshua himself he was the chief public man in Israel in the times of the conquest. See Josh. xxii. 13, 30, 31, 32; xxiv. 33. He was still high-priest in the time of the civil war with Benjamin, Jud. xx. 28. It follows that this war, the account of which is given Jud. xix.—xxi., was one of the earlier events of the times of the judges, instead of being the latest, as one might imagine from the place it occupies in the Book of Judges. That this war was itself preceded by the expedition in which the men of Dan captured Laish, in the north, is evident from the comparison of Jud. xvii., xviii., with Jud. xx. 1.

According to Jud. xx. 28, and the later notices, Phinehas was the successor of his father, Eleazar, in the high-priesthood. In this position he was the chief of the men to whom the custody of Moses' book of the law had been committed. If anything was done to the sacred writings of Moses and Joshua under his direction, it was done in the spirit of Moses and Joshua, within the lifetime of their personal associates. With these facts in mind, notice that the closing verses of the Book of Joshua bring the history up to the time of the death of Eleazar, the high-priest, and all that generation, that is up to the time when Phinehas of the next generation was already an old man. We shall presently find abundant proof that the earlier books of the Hexateuch, as well as its latest book, were either edited or annotated as late as the later years of Phinehas, and the question will become important whether there is any real evidence of redaction later than this. The instances are numerous and quite varied; we can notice only a few specimens in addition to those already cited.

The instances in which the proper name Dan is mentioned belong, of course, to a date after Laish had been captured and named Dan, Jud. xviii. 29, etc.; but this, as we have seen, was within the lifetime of Phinehas. The instances are Josh. xix. 47; Deut. xxxiv. 1; Gen. xiv. 14. The last may possibly be on

a somewhat different footing from the other two. The account of the death of Moses, Deut. xxxiv. 6, 10, with the phrase "unto this day," the account of Og's bedstead, and of the name Havvoth-lair, with the same phrase, Deut. iii. 10-15, the account of the Gibeonite tabernacle service, with the same phrase, Josh. ix. 27, and all parallel cases come under the same general statement. In some of the instances the phrase would be peculiar if assigned to the times of Moses, but in every instance it is entirely natural for some date not later than the times of Phinehas. If "Luz which is in the land of Canaan," Gen. xxxv. 6; Jud. i. 26, be understood as distinguishing the Palestinian Luz from the Luz afterward built in the land of the Hittites, then the phrase is later than the times of Moses, but not later than Phinehas. But it is not necessary to understand this phrase as post-Mosaic.

About sixty instances occur in Genesis, Exodus, Numbers, Deuteronomy, and Joshua of the names Hebron, Bethel, Debir, and Hormah, proving that these narratives were not written in their present form till after the adoption of these names instead of Kirjath-arba, Luz, Kirjath-sepher, and Zephath. But it is alleged that the change of name in each case occurred after the death of Moses, Jud. i. 10, 11, 17, 23. But in these cases it does not follow that the old name became extinct as soon as the new name was given. Prof. E. H. Palmer holds that the name Zephath is still in existence in the Arabic name Sebaita. See Palmer's *Desert of the Exodus*, p. 236, *et al.* Again, there is nothing improbable in the idea that the new name given after the conquest was the renewal of a Hebrew name previously given; the Biblical accounts give us to understand that this was actually the case with the name Bethel. In short, these instances have no great weight to prove that the passages where they occur contain anything later than Moses, and no weight at all to prove anything later than Phinehas.

No instances are more generally conceded to be of late origin than the law concerning the Israelite king, Deut. xvii. 14-20, and the passage concerning the Edomite kings, Gen. xxxvi., especially v. 31. But Moses needed no prophetic insight, but only ordinary human sagacity, to see that the Israelites were likely at some time to wish to establish monarchy, so that this was a case to be provided for. Further, according to the record, Moses held that Jehovah had made a promise, according to which a line of kings was to come from the loins of Abraham, Sarah, and Jacob, Gen. xvii. 6, 16; xxxv. 11. This being the case, there is no improbability in the idea of Moses giving such a law as the one in Deuteronomy. And this being admitted, this man who was looking forward to the existence of kings in Israel, and whose only interest in Edom lay in the fact that Esau was the elder brother of Israel, might very naturally mention the circumstance that there were as yet no kings in Israel, though the Edomites had already had kings for some generations. Until light can be thrown on the dates of the Edomite kings actually mentioned in this chapter, it cannot be shown that anything in the chapter is of a later date than Phinehas, or even than Moses.

If it be admitted that Ex. xvi. was written after the manna ceased (vs. 31, 35), that is, after the death of Moses (Josh. v. 12), and for a generation who had not seen the manna, and needed to have it described to them, that would not date the chapter later than Phinehas. The minuteness of the description does not indicate lateness of date; nothing is more common than for men to write careful descriptions of wonderful contemporary events for the information of coming generations.

The expression, "as Israel has done to the land of his possession," Deut. ii. 12, may easily be understood as referring to the conquest and division of the country east of the Jordan, and may therefore be the language of Moses himself. And even one who refers

this language to the conquests west of the Jordan can give no good reason for dating it later than the time of Phinehas. The phrase "within thy gates" (Ex. xx. 10, and elsewhere), and the law against removing landmarks (Deut. xix. 14) need not be regarded as post-Mosaic, for they apply to a people who have been settled and expect to settle again, as well as to a people actually settled when the law was put into the code. There is no reason for saying that "the mountain of Jehovah" (Gen. xxii. 14) presupposes Solomon's temple, or that "return to Egypt in ships" (Deut. xxviii. 68) is a reference to Jer. xliii. 7, or to anything else than the familiar fact that Egypt, before the times of Moses, already had a maritime slave-trade.

Especial stress has been laid, in certain quarters, on the words used in the Hexateuch to indicate the points of the compass—"seaward" for westward, Gen. xii. 8, and fifteen other places; toward the "Negeb" for southward, Ex. xxvi. 18; xxvii. 9, and many other places; "across the Jordan" for east of the Jordan, Deut. i. 1, and many other places. But these instances merely show that these parts of the *usus loquendi* of the Hebrew language originated north of the Negeb, and west of the Jordan; the allegation that they also show where the writer of these particular passages was located when he wrote is untenable. From the days of the patriarchs until now, you could not locate a man on any square yard of ground on the face of the earth where it would be inappropriate for him to say "across the Jordan," designating thereby the country east of the Jordan. We do not here need to say that Phinehas may have written these passages from his home west of the Jordan, for the use of these established geographical phrases affords no evidence of their having been written in one locality rather than another.

We add but a single instance. The Book of Jashar is cited in Josh. x. 12, 13. But some composition of David's was apparently written in the Book of Jashar (2 Sam. i. 18). If therefore the Book of Jashar was a work produced at some one date, that date was as late as David, and we have here at least one passage some centuries later than Moses and Joshua. If this view be accepted, a single gloss like this is not very important. But even in this case it is not necessary to accept the late date. The Book of Jashar, instead of being compiled at one time, may have been a collection that gradually accumulated from generation to generation; it may have received its name as early as Joshua's time, while additions continued to be made to it till David's time and later.

The instances thus far treated probably number not less than two hundred. The list could be greatly extended, but could hardly be made to include anything that would change its character as evidence. Evidently, most of the instances might be explained as having been written centuries later than Moses, provided there were proof that they ought to be so explained; but on the other hand, it is equally evident that most of them may supposably have been written by Moses himself, and that not one of them necessarily dates later than Phinehas.

This being the state of things, the argument from these instances in favor of the early date of these writings is not merely negative but positive. Historians are apt to compare the events they directly narrate with later events, up to their own times. Josephus, for example, speaking of Moses in Egypt, is led to mention that the city which he says Moses besieged was afterward called Meroe by Cambyses, and also to mention that the Greeks of his own time were familiar with the Egyptian ibis, *Antiquities*, II., x. 2. What Josephus thus does is what narrators are accustomed to do. It is quite prominently done in the Hexateuchal narratives of the times before Moses, and somewhat less prominently in those of the times of Moses and Joshua. They use the proper names that belong to the times of Moses and

later, up to the time when Laish was named Dan. When they speak of the birth of Moab and Ben-ammi, or of the oath at Beer-sheba, or of the shrinking of Jacob's thigh, or of the monument to Rachel, or of the laws made by Joseph in Egypt, they mention that "unto this day" there was in existence a people, or a proper name, or a monument, or a usage, connected with the event they narrate, Gen. xix. 37, 38; xxvi. 33; xxxii. 32; xxxv. 20; xlvii. 26. In their account of what occurred in the times of Moses and Joshua they do the same, Deut. iii. 14; xxxiv. 6, 10; Josh. iv. 9; v. 9; vi. 25; vii. 26; viii. 28, 29; ix. 27; x. 14, 27; xiii. 13, etc. To their account of the original giving of the manna they add a circumstance connected with the ceasing of the manna, some forty years later, Ex. xvi. 31, 35. This being their habit, how are we to account for it that no unmistakable allusion to any event later than the lifetime of Phinehas appears in these writings? The natural explanation is that that lifetime marks the date of the completing of the writings, and this explanation is thoroughly in accord with all the evidence we have thus far considered.

2. Another class of arguments to prove the late date of the Hexateuch proceeds on the assumption that certain principles of evolution apply in this case. This assumption is sometimes avowed, and it is actually one of the premises of the reasoning of some who do not avow it. It is assumed, for example, that the condition of the Israelites in early times was extremely barbarous and illiterate, so that such a literature as this was then impossible, and that it became possible by a process of development in civilization. But (to say nothing of the possibility that divine inspiration might produce authorship even among a rude people) we now know that there was a widely extended literature, in several languages, in Egypt, Syria, and Mesopotamia, before the time when Moses is said to have led the Israelites from Egypt. Prof. Osgood (in *Essays on the Pentateuch*, No. 12) has admirably summarized the testimony of recent investigators on this point, and at the present moment the work being done on the collection of Syria and Mesopotamian tablets found in the archives of Amenophis III. and Amenophis IV. of Egypt, is here adding fresh confirmation. See accounts of this "find" with references to additional sources of information, by A. H. Sayce, in the *Independent* of June 28, 1888, and by Dr. Francis Brown, in the *Presbyterian Review* of July, 1888.

Again, it is assumed that the law of development of religion requires that we should hold that the religion of Israel existed in the form of polytheism, then in the form of a relatively gross monotheism, and afterward in that of the higher monotheism represented by the prophets, all these being stages that must have preceded the ritualism found in the priestly law. Hence it is argued that the law could not have come into existence till after the writing of the books of the pre-exilic prophets. This reasoning has been sufficiently met by many writers, among others by Dr. Gardiner and Dr. Dwinell, *Essays on the Pentateuch*, Nos. 2 and 9, but it is very summarily met by Dr. Osgood, in the essay just cited, by the well-attested fact that an elaborate ritualism actually existed before the times of Moses, both in the regions whence the Israelites are said originally to have come, and in Egypt, where they made their long sojourn.

3. In proof of the late date of the Hexateuchal writings it is urged that they have virtually the same linguistic character with the latest books of the Old Testament, which could hardly be the case if they were written a thousand years the earlier. In reply to this, Dr. Franz Delitzsch (see articles of Dr. S. I. Curtiss in the *Hebrew Student* for March, April, May, and June, 1882; and in the *Presbyterian Review* for July, 1882) holds, first, that the range of linguistic changes is much less in the Shemitic than in the Western languages; secondly, that many of the lin-

guistic differences that once existed may be presumed to have vanished in the process of transferring the books from the old alphabet to the square alphabet; and thirdly, that, notwithstanding these facts, the differences now actually existing are quite appreciable. This has always been a correct and sufficient reply. Some of these linguistic differences are treated in the latest editions of Gesenius' *Grammar*, particularly in the treatment of the pronouns, and in Harman's *Introduction*, chap. x., and indeed in most Commentaries and Introductions that treat of the Pentateuch. The fact is that the Hexateuch, the later pre-exilic books, and the post-exilic books, each present characteristic peculiarities of vocabulary, of verbal form, and of syntax, and that the Hexateuchal peculiarities are largely those which are naturally to be assigned to the earlier stages of a language.

4. In pretty sharp contradiction with the argument just considered, though frequently urged by the same men, is the argument that the differences of style between different parts of the Hexateuch are such as to show that the passages must be by different authors, apparently living in different historical periods. The fact that there are in the Hexateuch great linguistic and rhetorical diversities is admitted. Considering the variety of subjects here treated, the variety of method of treatment, and the variety of the experiences that are said to have entered into the life of Moses, who would here expect anything else than great diversities of style, even if he supposed that Moses wrote every word of the Pentateuch? And if Moses and Joshua made use of works by earlier writers, employed secretaries, and left the writings to be edited by their immediate successors, we have additional explanations for this class of phenomena. The phenomena, in this way of looking at them, have no weight against the idea that Moses and Joshua are the proper authors of the Hexateuch.

5. This argument, however, recurs in the more specific and elaborate form of what is now currently called "the Pentateuchal Analysis." Work done in this analysis, and discussion concerning it, form the bulk of the contents of recent works and articles on the Pentateuch, but this subject is so fully treated in the *BRITANNICA* article, that there is no need of giving much space to it here, even for the sake of presenting a different view. Those who accept the so-called "analysis" are pretty well agreed in holding that the Hexateuch is a compilation from four previous compilations. These are now most commonly described as J, E, D, and P; that is, the works of the Jehovist narrator, the Elohist narrator, the Deuteronomist, and the Priestly narrator. They are pretty well agreed as to the present limits of P and D, and in the opinion that the main part of D was written in connection with the reform under king Josiah. They differ as to the dates of the other three documents, as to the dividing line between J and E, as to which parts of D belong to the original Deuteronomist, and which parts to each of a series of supplementary Deuteronomists, as to which parts of P are by the proper priestly narrator, and which parts by each of a supposed series of supplementary priest-scribes, as to the earlier writings that were incorporated into each of the four documents, and as to the multitude of other questions that arise.

It is readily seen that every theory of this sort is a complicated structure, built on no other foundation than conjectural explanations of circumstantial evidence, beset with difficulties that can be removed only by hypotheses framed for the purpose. The mere testimony in the case, as understood by those who hold the modified traditional view, will doubtless explain as many of the phenomena as can be explained by any of these more complex theories; and the explanation by testimony is of course to be preferred to the explanation by hypothesis. It follows that, notwithstanding the great weight of scholarly opinion now arrayed in favor of the various forms of what is cur-

rently called the Pentateuchal analysis, men who think for themselves are yet justifiable in hesitating to accept it. The nature of the arguments commonly urged against it may be learned by consulting the volumes named at the close of this article.

But supposing the current Pentateuchal analysis were accepted, so far as it pertains to the literary form and the mode of composition of these writings, it would by no means follow that we are compelled to accept the alleged late dates of the several parts of the Hexateuch. All the different literary processes involved may as well have been performed in the times of Moses, or before him, or after him within the lifetime of men who were associated with him, as at any later period. That the times of Josiah and Jeremiah were times when the Deuteronomic law-book was closely studied is very evident. It has been alleged in addition to this that the Deuteronomic legislation bears marks of having been made in those times and for those times. This is sufficiently refuted by Dr. Bissell and others. Similar claims are made, and are refuted by the same authors, as to the special affiliations between the priestly legislation and the times of Ezra and Nehemiah. A great deal has been made by some writers of the alleged absence of Egyptian elements from the Hexateuch, and the presence there of Babylonian elements; but, at present, no respectable scholar would allege that Egyptian elements are wanting, and the Babylonian elements may be readily explained by the known facts as to early relations between Egypt and Babylonia. The "find" described in the articles of Profs. Sayce and Brown, in the *Independent* of June 28, 1888, and the *Presbyterian Review* of July, 1888, is rich in material of this sort. It is further asserted that the Book of Ezekiel presupposes parts of the Hexateuch, but is in turn presupposed by most of the priestly legislation; and it is hence inferred that the priest-code is later than Ezekiel. This has been most satisfactorily refuted by Dr. Frederic Gardiner, in the *Journal of the Society of Biblical Literature and Exegesis*, 1881.

6. The argument that is regarded as strongest of all, in connection with the Pentateuchal analysis, to prove the late date of the successive parts of these writings, is the alleged silence of the Books of Judges and Samuel, both in regard to the Mosaic writings and in regard to the institutions described in them, combined with the alleged testimony of these books and the Books of Kings to the existence of institutions inconsistent with those of the Pentateuch. This argument is spread out into a great variety of specifications; it is impossible here to do more than mention a few of the most prominent. It is alleged that the Books of Judges and Samuel do not mention the *Torah*. The fact is that they use the noun *Torah* in 2 Sam. vii. 14, and the cognate verb, in the same sense with the noun, in Jud. xiii. 8 and 1 Sam. xii. 23. It is alleged that these books never cite the Hexateuch. It is true that they never use the formulas of citation, like those used in the Books of Kings and Chronicles, and in the New Testament; but they presuppose the events and the institutions described in the Hexateuchal writings, and abound in what seem to be verbal citations from them. A few out of very many apparent instances of verbal citation—instances in which the meaning depends upon the fact that the phrases are citations—are those in 2 Sam. vii. 1, 12, 24; 1 Sam. viii. 3, 5; Jud. xi. 14-27, ii. 1-3. Indeed, there is now a strong tendency among the advocates of the Hexateuchal analysis entirely to give up this allegation, and adopt an opposite view, namely, that the Books of Judges and Samuel are composite productions, formed from continuations of the same documents from which the Hexateuch was formed, and are therefore of a correspondingly late date.

It is alleged that these books are entirely silent as to the Pentateuchal system of institutions. This allegation, however, is materially modified by two admis-

sions. First, the allegation is not quite true as the text of these books now stands; the silence does not exist until the text has first been corrected and certain passages that break the silence (*e. g.*, 1 Sam. ii. 22) omitted as interpolations. Secondly, it is admitted that these books mention many particular institutions that belong to the Pentateuchal system. In replying to this and to several of the following allegations it should be conceded that, so far as appears from the evidence, the Pentateuchal system, if it existed during the period from the death of Joshua to the later years of David, was then in very imperfect operation. But the failure to enforce the law in those times neither implies that the law was then non-existent nor that it was then unwritten. Meanwhile the passages that presuppose institutions described in the Pentateuch are too numerous, too explicit, and too varied to be consistent with the allegation that the books are silent on this subject. Among the Pentateuchal institutions mentioned are the functions of the *Goel*, 2 Sam. iii. 27; xiv. 11; certain parts of the law of the Nazarite, Jud. xiii. 5; 1 Sam. i. 11; the prohibition of foreign gods, 1 Sam. vii. 3, etc.; usages respecting ceremonial cleanness, uncleanness, and holiness, 1 Sam. xx. 26; xxi. 5; religious laws against the eating of blood, 1 Sam. xiv. 32-34; against witchcraft, 1 Sam. xv. 23; xxviii., etc.; the priestly character of the Levites, Jud. xvii., etc.; the carrying of the ark by men, 2 Sam. vi. 13, and context; the burning of the fat before the priest's fee was due, 1 Sam. ii. 16 (*cf.* Lev. vii. 29-34); the offering of meal and wine with an animal victim, 1 Sam. i. 24; the technical terms *שְׂמֵחָה לַיהוָה*, 1 Sam. iii. 14; the distinction of burnt-offerings, peace-offerings, etc., 1 Sam. x. 8; xiii. 9, *et al.*; sacrifices connected with vows, 1 Sam. i. 21; sacrifices for certain seasons distinguished from particular sacrifices, 1 Sam. i. 21; the shewbread, 1 Sam. xxi. 6; the high-priest's ephod, 1 Sam. ii. 28, *et al.*; the sanctuary tent and the sacred ark, 1 Sam. ii. 22; 2 Sam. vi., *et al.*; the service of the sanctuary by priests descended from Aaron, 1 Sam. ii. 28, and many places; its being for "all Israel," ii. 14, 22, 24, 28; iii. 20, *et al.*; at least one annual festival, with sacrifices peculiar to it, to which Israel came up, 1 Sam. i. 3, 7, 9, 21; ii. 19, etc.; eating and drinking in Shiloh (before the *LORD*), as a part of the celebration of the festival, vs. 7, 9; in fine, the existence of rigid ceremonial laws, which it was a sin to neglect, 1 Sam. ii. 29; xiii. 11-13; 2 Sam. vi. 7, etc. The list might be greatly extended. Certainly, these books mention the Levitical laws and the other Pentateuchal institutions as fully as any one has a right to expect on the supposition that these were then already in existence. Their silence, therefore, in regard to other particulars has no weight to prove that the laws were then non-existent.

But it is alleged that in many of the instances given, and in other like instances, the details described in these books are different from those described in the Pentateuch, and that this fact proves the Pentateuchal description to have been then non-existent. The fact alleged is in part admitted, but the inference of wholly denied. The cultus described in the Book of Nehemiah includes many details that vary from those of the Pentateuch; for example, the pulpit for the reading of the law, the processional services, the tax of a third of a shekel, the wood-offering. The ritual of the scribes included the sacrifice of the cock, the pouring of water and the use of citrons at the feast of tabernacles, the ceremonies for receiving proselytes. No one claims that these variations prove that the written law was in their time non-existent, and there is no more ground for such a claim in the variations of the times of Samuel. It is further alleged, however, that the institutions described for the times of the judges, and for the later times, up to the reign of Josiah, are not only variant from those described in the Pentateuch, but are inconsistent with

them. The strongest alleged fact of this kind is that the law in Deut. xii. forbids sacrifices to Jehovah, except at a central sanctuary, while in the times of Gideon, of Jephthah, of Samuel, of David, of Elijah, it is represented to have been orthodox to sacrifice at a great number of different sanctuaries. For details under this argument and the reply to it the reader is referred to books on the subject, and to the article **TABERNACLE** in this work. In general the reply is that in many of the alleged instances the sacrifice spoken of is to be regarded as illegal, so that these instances do not count in the argument. The remaining instances may all be referred to one of three classes: Either they were merely private sacrifices, such as are explicitly provided for in the law itself (Deut. xii. 15, 21, where the verb is *זָבַח*, or they may have been in the presence of the ark, and therefore properly at the one central sanctuary, the sanctuary itself being movable till the building of Solomon's temple, or they occurred in circumstances when Israel was not, within the meaning of the law, at "rest from all his enemies round about" (Deut. xii. 10), and was without the place chosen by Jehovah "to put his name there" (Deut. xii. 5)—that is, in circumstances when the law was necessarily in abeyance.

Similar arguments drawn from the statements of the several books concerning the priesthood, from those concerning the three annual festivals, and from those concerning various other matters, are drawn out at length, and refuted at length, in the different works on these subjects. The results of the discussion may be fairly summed up in the proposition that the Books of Judges and Samuel, like those of Kings, mention and in other ways clearly presuppose earlier sacred writings containing wholly or in part the same contents with our Hexateuch. They mention these writings and the events and institutions described in them as fully as could fairly be expected on the supposition that the writings date from the times of Moses and his immediate successors. The institutions they mention are either mentioned with disapproval, expressed or fairly implied, or are institutions consistent with the Pentateuchal laws.

Literature.—The literature on this subject is immensely voluminous. Reference may be made to the following: B. P. Stebbins, D. D., *A Study of the Pentateuch* (Boston, 1881); Henry M. Harman, D. D., *Introduction to the Study of the Holy Scriptures* (New York, 1884); of this work pp. 66-270 are devoted to the Hexateuch; *Essays on Pentateuchal Criticism by Various Writers* (New York, 1888). A compact presentation of the history of Pentateuchal criticism is given by Dr. C. A. Briggs in the *Presbyterian Review* for January, 1883.

The views of the dominant school of the advocates of the late date of the Hexateuch are to be found, of course, in the writings of Graf, Robertson Smith, Kuenen, Wellhausen, Kayser, Stade, etc. Probably the best one book of this sort accessible to English readers is *The Hexateuch*, by Kuenen, translated by P. H. Wicksted (London, 1886). Good, compact statements of the views of men of this school are given in several of the works written in refutation of them and mentioned in these notes. That given in Dr. Green's little book on the *Hebrew Feasts* is sufficient.

Dillman, Nöldeke, and Schrader are good representatives of the school of critics who accept mainly the so-called Pentateuchal analysis, but deny the post-exilic origin of the priest code. A good summary is given in the "Introductory Preface" of *The Cuneiform Inscriptions and the Old Testament*, by Schrader (Berlin, 1882), and English translation by Whitehouse (London, 1885).

Perhaps the most complete single work attacking the "Pentateuchal analysis" and the destructive arguments based upon it is *The Pentateuch, its Origin and Structure*, by Dr. E. C. Bissell (New York, 1885). Dr. W. H. Green has assailed the analysis itself, and some of the consequences drawn from it, in *Moses and the Prophets*, and in *The Hebrew Feasts*, and in his series of comments on the International Sunday-School Lessons, published in the *Sunday-School Times*.

The article "Pentateuch" in the Schaff-Herzog *Encyclopædia* gives a relatively full list of the literature of this subject. Other lists are found in the works to which we

have referred and in the various commentaries, introductions, and articles. Dr. Bissell's list has about 2000 titles. The list of works on Exodus given by Dr. Francis Brown in the *Old Testament Student* for November, 1886, with brief comments on some of the works mentioned, covers nine large pages.

In *Hebraica*, July, 1888, is an article on "Pentateuchal Analysis," by B. W. Bacon, which mentions the literature and tabulates the views held by the reconstructive critics up to date. A discussion of the whole question, by Prof. Wm. R. Harper and Prof. Wm. H. Green, is promised in the same magazine. (W. J. B.)

PENTECOST. See **TABERNACLE**.

PEORIA, a city of Illinois, county-seat of Peoria co., is on the W. bank of the Illinois River, at the outlet of Peoria Lake, 157 miles S. W. of Chicago. It is on a plateau surrounded by bluffs rising 180 ft. above the lake and nearly a mile distant. It is an important railroad centre, eleven roads already crossing or terminating here. These connect it with Chicago, Cincinnati, St. Louis, and other prominent cities. The Union Depot furnishes accommodation for eight of the railroads. By the Illinois River also Peoria has communication with the Mississippi and by the Illinois and Michigan Canal with the Great Lakes. Peoria has a stone court-house, a U. S. government building, city-hall, jail, and workhouse. Of its ten parks the largest is Jefferson, with 35 acres. There are 45 churches, the finest of which are the Roman Catholic Cathedral, the Congregational, Calvary Presbyterian, First Methodist, and the Universalist Church. Besides the high-school there are 12 public school buildings, several church and private schools, a German free school, business colleges, a free public library, a law library, a college of physicians and surgeons, and a scientific association. The police and fire departments are efficient. The city is lighted with gas and electricity, and is provided with water by the Holly system. The street-car lines operate 10½ miles of double track. There are three hospitals, the Bradley Home for Aged Women, and the Home of the Friendless. Peoria has 6 national, 2 private, and 2 savings banks, 7 daily and 7 weekly newspapers, 5 being German. The leading manufacture is distilling, in which Peoria surpasses all other cities in the United States. In 1885 there were produced 18,602,992 gallons of spirits, consuming 49,185,389 bushels of grain. The other manufactures comprise agricultural implements, beer, watches, stoves, starch, glucose, flour, oatmeal, and pottery. The grain-elevators have a total capacity of 2,700,000 bushels. In the lower part of the city are large stockyards through which 350,000 animals passed in 1886. Peoria is surrounded with fertile, undulating prairies, which contain mines of bituminous coal. In the city water impregnated with sulphur is obtained by artesian wells and largely used for medicinal purposes. Peoria was made a trading-post by La Salle in 1680, and a settlement here was called La Ville de Mallet. Afterwards Fort Clark occupied the site, and in 1819 Peoria was founded. Its population in 1870 was 22,849 and in 1880 had increased to 29,315, but on the basis of the city directory of 1886 (containing 46,520 names) it is estimated at 50,000.

PEPPERELL, SIR WILLIAM (1696-1759), was born at Kittery Point, Maine, June 27, 1696. The son of a fisherman of Welsh descent, he became a wealthy merchant, and in 1727 was elected a member of the Council of Massachusetts. In 1745 he was appointed to command the New England expedition against Louisburg, and in less than eight weeks captured this fortress, June 17. This exploit won for him a baronetage and in 1749 a colonelcy in the British army. He was acting governor of Massachusetts 1756-58, and was made lieutenant-general shortly before his death, July 6, 1759. His grandson, William Pepperell Sparhawk, who succeeded to his title and estates in 1774, soon lost them by his adherence to the British cause. He died in London Dec. 17, 1816.

PEQUOTS, or **PEQUODS**, an Indian tribe of the

Algonkin family, at the time of the settlement of Connecticut were found around the Thames River. They were a branch of the Mohegans and were noted as warriors. They acquired a supremacy among the native tribes and made treaties with the Dutch and English. Gov. Endicott, however, thought it necessary to send an expedition among them, and thenceforward they were hostile to the whites. In May, 1637, Capt. John Mason, being sent against them from Hartford, surprised and burned their fort near Groton. Several hundred men, women, and children perished, but the rest of the tribe continued the war until they were overpowered in Fairfield swamp. Many of them were sold as slaves in the West Indies, others were scattered among neighboring tribes, yet a remnant was finally gathered and recognized by law. They lived partly at Ledyard and partly at North Stonington. In later wars they assisted the colonists. Some of them removed to Oneida co., N. Y., and thence to Green Bay, Wisconsin.

PERCH, a well-known game-fish, which is very common in the rivers of North America, Europe, and Northern Asia. It is a member of the *Percide*, an extensive family of acanthopterygious fishes. The perch has an elongated body, covered with ctenoid scales, with two dorsal fins, the first having 13 or 14 spines, the second being flexible, while the anal fin is small and far back, and the ventrals thoracic, each with one spine and five rays. The skeleton has more than 24 vertebrae. All the teeth are villiform, without canines, occurring on the palatine bones and the vomer, the tongue being toothless. There have been 14 species of perch described, all inhabiting fresh water. Of these the American yellow perch (*Percu flavescens*) is generally held to be the only true species in the United States. It is very widely distributed in the lakes, ponds, and streams of the Middle and Northern States and the British provinces, is easily taken by hook or net, and is considered an excellent table-fish. This species is ordinarily below 10 in. in length, but is occasionally found of 12 to 15 in. in length and 2½ lbs. weight. It is of a greenish yellow color on the back and golden yellow on the sides, the back being banded with 6 to 8 transverse dark bands. The under parts are white, the dorsal and caudal fins greenish brown; the pectorals, ventrals, and anal golden orange; the body compressed and elongated, with the lateral line concurrent with the line of the back.

As a game-fish the perch is a bold biter and may be taken with worm or small fish, affording fair sport, but requiring no great skill in its capture. It is a favorite fish with rural anglers, and is esteemed a great delicacy in the interior regions where sea-fish are not easily obtained. The European yellow perch (*P. fluviatilis*) is generally distributed in Europe and Northern Asia. It resembles *P. flavescens* in coloration, bites well, and is very tenacious of life out of water. Its flesh is considered excellent. It frequents still waters, sometimes descending into brackish, attains in rare cases a weight of 5 pounds, and is exceedingly prolific, more than 1,000,000 eggs being borne in one spawn.

There are several other fish which are commonly called perch, such as *Corvina oscula*, the white perch of the Ohio, and *Pomotis vulgaris*, the bream, to which is often given the name of pond perch. Some sea-fish of the genus *Serranus* are also known as perches. There are 26 species in all of these, many of them handsome fish, abundant in the warmer seas. The common American salt-water perch, plentiful around the rocky shores of New England, is *Ctenolabrus ceruleus*. This fish has an elongated, scaly body, varying in length from 6 to 10 in. and deviating considerably in color. It has a single dorsal fin with strong and piercingly sharp spines, and is an excellent table-fish. Great numbers are caught in nets or by hook, and are kept alive in large floating cars until

needed for market. It is a favorite fish with the anglers of those shores. (C. M.)

PERKINS, CHARLES CALLAHAN (1823-1886), artist, was born at Boston, March 1, 1823. He graduated at Harvard in 1843, and went to Rome, and afterwards to Paris, where he studied painting under Ary Scheffer. During other visits to Europe he studied etching, which he used in illustrating his works on Italian art. His life was devoted to promoting the culture of the fine arts, especially in Boston, where he assisted in founding the museum for that purpose. From 1869 to 1879 he was president of the Boston art club, and from 1875 to 1886 of the Handel and Haydn society. He was accidentally killed by the overturning of a carriage at Windsor, Vt., Aug. 25, 1886. Besides delivering many lectures, Perkins published *Tuscan Sculptors* (2 vols., 1864); *Italian Sculptors* (1868); *Raphael and Michelangelo* (1878); *Sepulchral Monuments in Italy* (1883); *Historical Handbook of Italian Sculptors* (1883).

PERKINS, JUSTIN (1805-1869), an American missionary, was born at West Springfield, Mass., March 12, 1805. He graduated at Amherst College in 1829, and after studying theology at Andover was sent to Persia in 1833 by the American Board of Commissioners of Foreign Missions. He established himself at Oroomiah and labored especially among the Nestorians, into whose language he translated the Bible and several other works. In 1842 he returned to the United States, bringing the Nestorian bishop, Mar Yohanan. After another visit in 1848 he finally returned in 1869, and died at Chicopee, Mass., on the last day of that year. In English he published *Eight Years in Persia* (1843), and *Missionary Life in Persia* (1861).

PERKINS, THOMAS HANDASYD (1764-1854), merchant and philanthropist, was born at Boston, Mass., Dec. 15, 1764. He engaged in the East India trade, and, having acquired great wealth, retired from business in 1823. He was for many years a member of the State Legislature, and in later life was a liberal contributor to the Mercantile Library, the Massachusetts General Hospital, the Boston Athenæum, and other public enterprises. In 1827 he projected the Quincy Railway, the first built in the United States. He was active in promoting the erection of the Bunker Hill Monument. He gave his mansion on Pearl Street as an asylum for the blind (see BLIND). He died at Boston, Jan. 11, 1854.

His nephew, JAMES HANDASYD PERKINS (1810-1849), after being a clerk in his counting-room, settled at Cincinnati in 1832, and was successively lawyer, editor, and Unitarian minister. He was president of the Cincinnati Historical Society and published *Annals of the West* (1847).

PEROWNE, JOHN JAMES STEWART, an English clergyman, was born at Burdwan, Bengal, March 13, 1823. He is of French Huguenot descent, and was educated at Norwich Grammar School and at Corpus Christi College, Cambridge. He graduated B. A. in 1845 and M. A. in 1848, having won several prizes by scholarship. He was elected a Fellow of his college in 1849, and was select preacher to the University in 1853, and later years. He was also professor in King's College, London, and assistant preacher at Lincoln's Inn. In 1862 he was made vice-principal of St. David's College, Lampeter, and held that position ten years. In 1873 he was made a Fellow of Trinity College and in 1875 Hulsean professor of divinity at Cambridge. In 1878 he was made dean of Peterborough. From 1870 to 1884 he assisted in the revision of the English Old Testament, and he is editor of the *Cambridge Bible for Schools* (1877, sqq.). He published *The Book of Psalms, a New Translation, with Notes* (2 vols., 1864-68); *Hulsean Lectures on Immortality* (1869) and some sermons, besides contributions to various periodicals.

PERROT, GEORGE, French archaeologist, was born at Villeneuve St. Georges, Seine-Oise, Nov. 12, 1832.

He was educated at the Normal School in Paris, and at the French School at Athens. In 1861 he undertook archæological exploration in Asia Minor, and soon discovered an important monument at Ancyra. In 1872 he was made professor of Greek in the Normal School, and in 1877 professor of archæology in the University of Paris. His publications comprise *Exploration archéologique de la Galatie et de la Bithymie* (1863-73); *L'Île de Thasos* (1864); *Essai sur le Droit public et privé de la République athenienne* (1867). With Charles Chipiez he published *Histoire de l'Art dans l'antiquité* (4 vols., 1881-4). Vol. I. of this valuable work treats of Egypt; Vol. II. of Assyria, Babylonia, and Chaldæa; Vol. III. of Phœnicia and Syria; and Vol. IV. of Asia Minor and Cyprus.

PERRY, MATTHEW CALBRAITH (1794-1858), commodore, was born at Newport, R. I., April 10, 1794. His father, CHRISTOPHER RAYMOND PERRY (1760-1818), served with distinction in the Revolutionary navy, and when the navy was reduced to insignificance was made collector of Newport. His five sons all served in the navy and were distinguished in the war of 1812. Matthew had been appointed a midshipman in 1809 and became lieutenant in 1813. In 1819 he selected the locality for the first settlement of Liberia under the auspices of the American Colonization Society. He afterwards cruised in the West Indies, then infested with pirates. He promoted the introduction of steam as a motive power in the navy. After commanding various squadrons he was engaged in the war with Mexico, and took part in the siege of Vera Cruz. His most memorable work was the expedition to Japan in which he negotiated, March 21, 1854, the treaty which opened that empire to western civilization. The narrative of the expedition was edited from his notes by Rev. F. L. Hawks and George Jones (3 vols., 1856). He died at New York, March 4, 1858. A bronze statue has been erected to his memory in Truro Park, Newport. His *Life* has been written by W. E. Griffiths (Boston, 1887).

His elder brother, OLIVER HOWARD PERRY (1785-1819), has even greater renown in American history, yet for a single exploit. Born Aug. 23, 1785, he entered the navy in 1799, and served in the war against Tripoli. Next engaged in the less honorable duty of enforcing the embargo, he had the misfortune to lose his vessel on a reef in Long Island Sound, but was exonerated of blame by a court of inquiry. In 1812 he at first commanded a flotilla of gunboats in New York harbor, then served under Commodore Chauncey on Lake Ontario, and in March, 1813, was sent by him to equip a squadron on Lake Erie. The vessels gathered there being too small, others were hastily constructed at Presque Isle, now Erie, but were closely blockaded by the British fleet under Capt. Barclay. On Aug. 12th Perry contrived to get his vessels out of port, and on Sept. 10th he encountered the British fleet near Put-in-Bay. He had in all nine vessels with 54 guns and 492 officers and men. Barclay had six vessels with 63 guns and 502 officers and men. The British guns had longer range and their fire was concentrated on the *Lawrence*, Perry's flag-ship, which had outsailed her consorts. After four-fifths of her crew were disabled and her guns rendered useless, Perry entering an open boat under heavy fire, transferred his flag to the *Niagara*, half a mile off. Then leading his vessels, now favored by the wind, through the enemy's line, he ordered them to deliver a cross-fire which in a few minutes compelled four of the British vessels to strike their flag. The other vessels attempted to escape but were overtaken. Perry immediately wrote to Gen. Harrison the famous despatch: "We have met the enemy and they are ours—two ships, two brigs, one schooner, and one sloop." This brilliant action was the first in which he was engaged. His loss in killed and wounded was 123, that of the British was 400, including Capt. Barclay, wounded. Congress gave Perry a vote of thanks, a gold medal, and the rank of cap-

tain, and bestowed other rewards on his gallant subordinates. The British having now lost control of Lake Erie, evacuated Detroit. Gen. Harrison pursued them and was assisted by Perry at the battle of the Thames a few weeks later. In the next year Perry commanded a body of marines on the Potomac. He afterwards served in the Mediterranean under Decatur. In 1819 he was sent in command of a squadron to the Caribbean Sea. He was seized with yellow fever and died at Port Spain, Trinidad, Aug. 23, 1819. His remains were removed by order of Congress and buried in the cemetery at Newport, where the State of Rhode Island erected an obelisk. In September, 1860, a marble statue by Walcutt was erected to his memory at Cleveland. A bronze statue by W. G. Turner was erected at Newport in 1885. Capt. Perry's *Life* was written by Capt. A. S. Mackenzie (1843).

PERRY, THOMAS SERGEANT, educator and author, was born at Newport, R. I. He is a grandson of Capt. O. H. Perry, and is also descended from Benjamin Franklin. After graduating at Harvard in 1866 he studied at Paris and Berlin, and was made tutor in German at Harvard in 1868. He was editor of the *North American Review* from 1872 to 1874, and afterwards returned to Harvard as instructor in English. He has been busily engaged in lecturing and writing on literary topics. Among his publications are *Life of Francis Lieber* (1882); *English Literature in the XVIIIth Century* (1883); *From Opitz to Lessing* (1885); *History of Greek Literature* (1888). He has contributed to this *Supplement* on "American Literature," "Carlyle," etc.

PERRY, WILLIAM STEVENS, bishop and historian of the American Episcopal Church, was born at Providence, R. I., Jan. 22, 1832. He graduated at Harvard College in 1854, and was ordained priest in 1858. After having charge of churches at Nashua, N. H., Portland, Litchfield, Conn., in 1869 he became rector of Trinity Church, Geneva, N. Y. In 1876 he had been chosen president of Hobart College there, but in September he was made bishop of Iowa. From the commencement of his ministry he had given special attention to the history of the American Church, and was associated with Rev. Dr. F. L. Hawks in historical researches and publications. Together they issued one volume of the *Journals of the General Conventions of the P. E. Church, 1794-1835* (1861), and the *Documentary History of the P. E. Church* (2 vols., 1863-4). In 1868 Dr. Perry was formally appointed historiographer of the church. Of the *Historical Collections of the American Colonial Church* there have appeared volumes relating to Virginia (1871), Pennsylvania (1872), Massachusetts (1873), Maryland (1878), Delaware (1878). Bishop Perry has also published *Handbook of the General Conventions and Journals of the General Convention, 1785 to 1835* (3 vols., 1874); *Historical Sketch of the Protestant Episcopal Church, 1784-1884* (1884); and *The History of the American Episcopal Church, 1587-1883* (2 vols., 1885). Bishop Perry has taken part in the Old Catholic Conference at Bonn, in 1875, and in the Pan-Anglican Councils at Lambeth in 1878 and 1888.

PERSIMMON, the fruit of *Diospyros Virginiana*, or the Date Plum, a member of the order *Ebenaceæ*, of which the hard and dark-colored heart-woods of some species yield the different kinds of ebony. The persimmon is a native of North America, the tree being usually of small size, but occasionally reaching a height of 70 ft. Its wood is very hard and of blackish color, and is of value to replace boxwood in the manufacture of shuttles, and also for hat-making and other turnery. The stem exudes a kind of gum. The fruit ripens as high as 41° N. lat. in Illinois. It is of globular form, of the size of a large plum, and in its unripe state is exceedingly astringent, which quality it does not lose until over-ripe. When hard frosts bring it to the verge of decay it becomes soft and very sweet and agreeable in flavor. There are several other

species which bear edible fruit, such as *D. discolor* of the Philippines, which yields a fine fruit, and *D. Kakii* of Japan, whose fruit is of the size of an apricot and is dried as a sweetmeat by the Chinese. (C. M.)

PERSONAL ESTATE. See PROPERTY.

PERU, a city of Indiana, the seat of Miami co., on the N. bank of the Wabash River, 67 miles N. of Indianapolis, on the Wabash, St. Louis, and Western, the Detroit and Ecl River, and the Michigan City and Indianapolis Railroads, being the division head-quarters of the two latter. It has a court-house, high-school, and 3 other schools, 4 hotels, 2 national banks, 2 weekly and 2 daily newspapers, 7 churches. Its industrial works comprise woollen, bagging, and 1 planing mill, 3 large foundries, and railroad shops, basket and wood-work factories. It is lighted with gas and has water-works. Settled in 1833, it was incorporated in 1834. Its property is valued at \$5,000,000 and the public debt is \$150,000, the annual expenses being about \$20,000. The population in 1880 was 5280. The surrounding country is agricultural. Petroleum has been found at a depth of 880 ft.

PETER. The various names of this apostle are given in the ENCYCLOPÆDIA BRITANNICA, as well as the circumstances connected with his becoming a disciple of our Lord. But the important events in which he evinced his priority among "the twelve" are not so clearly set forth.

There is little or no evidence that the confession at Cæsarea Philippi (Matt. xvi. 13-23; Mark viii. 27-33; Luke ix. 18-22) is identical with the incident narrated in John vi. 66-69. The latter occurred immediately after a discourse in the synagogue at Capernaum, in which Jesus, by rebuking the multitudes for following him because he had fed them, virtually turns the popular feeling against himself. This was shortly after the feeding of the five thousand, the only miracle narrated by all four evangelists. The confession at Cæsarea Philippi was made after the opposition in Galilee had well-nigh closed that region to the ministry of Jesus. The intervening journeys all show increasing antagonism. But thus the disciples were trained to see more clearly the real purpose of their Master's mission. On the borders of the Holy Land, in privacy, Peter, as the spokesman of the twelve, made his confession. It indicates a great advance from the answer given in John vi. 68. The much disputed sentence, "Upon this rock will I build my church," must, therefore, be interpreted in a way that recognizes the priority of Peter. For his name is first in all the lists of the apostles. (The four fishermen are always named first.) Furthermore, the verbal play upon his name seems to compel a reference to the person bearing that name. But priority and primacy are not identical terms, and the personal infallibility of Peter is contradicted by the interview which follows (Matt. xvi. 21-23; Mark viii. 31-33), as well as by the incident at Antioch, when Paul rebuked him (Gal. ii. 11, 12); the very last historical notice of Peter.

The narrative of his attempted walking on the water (Matt. xiv. 28-31), though peculiar to Matthew, is quite significant, since it illustrates alike the strength and weakness of the apostle's character, and represents in act what was expressed in word at Cæsarea Philippi. That his conceptions of the Messianic kingdom were at first purely Jewish is evident, but the Gospels are never read aright until they are regarded as narratives of the training of the disciples to higher conceptions of their Master's Person and work. The Tübingen school ignores this, in order to prove that the twelve were Judaizing to the last, even after the gospel had been widely preached to the Gentiles. But all the evangelists plainly show the preparations for a wider view of the gospel on the part of the twelve. Nor is there any evidence that the Fourth Gospel seeks to present John as more prominent than Peter. Even the threefold denial, narrated with varying details in

all four Gospels, shows Peter in the same character and prominence. The special appearance of the risen Lord to Peter (1 Cor. xv. 5; Luke xxiv. 34) is a recognition of his leadership; all the more significant, because it is stated by the very writers whom the Tübingen school assume to be anti-Jewish in their coloring of the history.

We now pass to the narrative in the Acts of the Apostles. The last half of that book is regarded by some critics as representing Paul in too compromising an attitude to Jewish Christianity; and the same critics object to the earlier half, because it presents Peter as too favorable to the Gentiles. But the narrative is a consistent setting forth of the way in which this man, in spite of his Jewish habits and prejudices, was led to see the universal scope of the gospel. That he proved weak in practising his own avowed principles at Antioch (Gal. ii. 11, 12) only shows that this was the same Peter depicted in the Gospels; advanced in grace and knowledge, but not yet perfect. The persistent attempt "to reconstruct not only church history but also the New Testament," on the theory of a permanent alienation of these two apostles, seems to be disapproved by Dr. Hatch; but he attaches entirely too much weight to the opinions of the critics that uphold this theory. For example: in discussing the question whether Peter ever was at Rome, the *Clementines* are introduced. The historical romance contained in this literature has been used by the Tübingen school as a proof of the sharp antagonism between the Jewish and Gentile elements in the early church. The *Clementines* do exhibit a process of evolution in literature, but they do not prove the main point of the Tübingen theory, nor is it certain that Simon Magus always represents Paul. Yet the ENCYCLOPÆDIA BRITANNICA gives as authorities on the *Clementines* only writers of the Tübingen school, and allows a place to the suggestion that the passage in Acts viii. 14-24 is not authentic, but a "reflex of the later legends in which the name of Simon Magus was substituted for that of St. Paul as a representative of false Christianity." Probably no more groundless theory than this has been proposed by skeptical criticism. (An English translation of the *Clementines* with notes by the writer of this article will be found in the *Ante-Nicene Fathers*, Amer. ed., vol. viii., p. 75-346.)

The later history of the Apostle Peter has been confused by the extravagant claim of a twenty-five years' residence at Rome. That he went to Rome toward the close of his life, enduring martyrdom there under Nero, is exceedingly probable; but he could scarcely have been there when Paul wrote his Epistle to the Romans (A. D. 58). Nor is it likely that "Babylon" in his own epistle (1 Pet. v. 13) refers to Rome. It should be noted that many Protestant scholars, including those of very different theological tendencies, hold the opinion that Peter died at Rome. Ecclesiastical tradition is singularly unanimous in supporting the main fact. That Peter and Paul were martyred at the same time is also the traditional belief, but for this there is not the same amount of patristic evidence. It seems quite unlikely that the two apostles ever were in Rome at the same time; certainly Paul makes no allusion to the presence of Peter in any of the epistles written from that city.

The character of Peter is readily understood. "He was the strongest and the weakest of the Twelve. He had all the excellences and all the defects of a sanguine temperament" (Schaff, *History of the Christian Church*, vol. i., p. 253. Compare the same, pp. 253-263, on "the Peter of history and the Peter of fiction"). He has been called the apostle of hope, and his epistles, written when divine grace had matured his piety, are full of consolation. In his speeches, as recorded in the Acts of the Apostles as well as in his epistles, there is a tone of humility in sharp contrast with the claims that have been connected with the primacy assumed to have been transferred from him to

the bishops of Rome. The theory of his advance in knowledge and piety, indicated in the New Testament and accepted in this article, accords with the final word of exhortation from his pen: "But grow in the grace and knowledge of our Lord and Saviour Jesus Christ" (2 Pet. iii. 18, R. Vers.). (M. B. R.)

PETER, EPISTLES OF. 1 **PETER.** The genuineness of this letter has only been assailed by those who have a preconceived theory of the origin of the New Testament writings. The external authority is very strong, reaching back to the sub-apostolic age. The internal evidence is equally so, for the coincidence of thought and expression with other New Testament writings proves nothing against it. (See the various theories noticed in the *ENCYCLOPEDIA BRITANNICA*.) It seems to have been written from Babylon, and to Christians in Asia Minor. Some think "Babylon" is a mystical name for Rome, but as the most probable date is A. D. 63, just before the persecution under Nero, and as it is unlikely that Peter had visited Rome at that date, the term is better understood in its natural sense. The contents accord alike with the gospel as set forth in the other apostolic writings and with the character of the apostle. It should be added that the passages respecting the descent of Christ into Hades (iii. 18, iv. 6) have occasioned much discussion, and that at present the possibility of salvation being offered to those who have died without accepting Christ is based upon these passages by some theologians.

2 **PETER.** This epistle presents peculiar difficulties. Doubts about the genuineness of the Pauline epistles are usually of modern origin, but from early times this epistle has been "disputed" (so Eusebius). Jerome refers to doubts, and Calvin (in his commentary on this epistle) suggests that it was written by one of Peter's disciples, by his command. Even those who believe that Peter wrote it must confess that "it is, perhaps, the least attested writing of the New Testament" (Gloag, *Introduction to Catholic Epistles*, p. 204). Yet, despite the weakness of the early testimony, even in the case of this "least attested writing," the preponderance of probability is in favor of the genuineness of the epistle.

1. *The objections.*—(1) The want of early testimony; (2) the allusion to Paul's epistles (2 Pet. iii. 16), as a whole, implying a late date; (3) the differences in style and diction from the first epistle; (4) the opposition to Gnostic errors of a later date than the apostolic age; (5) especially the striking correspondence between chap. ii. and the Epistle of Jude. In regard to (1) it may be remarked that this is purely negative evidence. After all doubtful allusions are omitted, there yet remains strong positive testimony to its genuineness. The allusion to the epistles of Paul does not furnish a strong argument against this epistle. The reference may be to a few of the former, not to a complete collection. Paul had certainly, before the earliest date to which this epistle is assigned, written several letters to Asia Minor, the region to which this letter was addressed. The differences of style between this and the first epistle do not seem to be greater than those existing in the case of the acknowledged Pauline epistles. All arguments from such premises are notoriously precarious, especially when the document in question is so brief. The errors combated are not necessarily those of a later age than that of the apostles. The correspondences with the Epistle of Jude present the most serious difficulty. The current of opinion now sets in favor of the view that the Epistle of Jude was earlier, and that this letter is dependent on that. But many holding this view still accept Second Peter as genuine.

2. *Evidence of Genuineness.*—(1) The similarity of style and sentiment to the First Epistle, notwithstanding the acknowledged differences. (2) The similarity to the speeches of Peter recorded in the Acts of the

Apostles. (3) The high character of the letter itself. (4) The superiority to the writings of a later age. On this rock most of the destructive criticism destroys itself. (5) The fact that it claims to be written by Peter, and the moral impossibility of such a document being the work of a wilful forger; this argument derives additional strength from the reference to the transfiguration (chap. i. 17, 18), and the words "we did not follow cunningly devised fables" (chap. i. 16). Despite the lack of early testimony and its omission from the Syriac version, (6) There is a general recognition of its genuineness and canonicity in those ages when such questions became prominent. (7) Were it the product of a later age there would be more positive evidence of coloring from that age; for example, the particular form of heresy against which it was aimed would be readily recognized in some error prevalent in the second century. But no such identification is possible. (8) No motive for forging such a letter can be discovered. (9) While the "subjective test" in itself proves nothing, yet in view of all the above considerations the practical value of the epistle to Christian people for so many generations has much weight in determining whether it should be classed with the other New Testament books. It ought not to be classed with them, if its claims respecting itself are false.

3. The epistle seems to have been addressed to the same circle of readers in Asia Minor as the First Epistle (2 Pet. iii. 1), and to this view no objection can be raised, if the genuineness be accepted. The errors it combats were those that might be naturally developed in the region and among the people for whom the First Epistle was designed. Persecution is implied in one letter, heresy in the other; but this does not involve a different circle of readers, nor does it make against the genuineness of the later epistle.

4. The *design* of the epistle is twofold: (1) to warn against error and the teachers of it; (2) to exhort the readers to advance in holiness. This appears in the closing paragraph (chap. iii. 17, 18), as well as in the structure of the epistle. While we cannot definitely identify the false teachers referred to, it is still more difficult to identify them as the errorists of a later age. A number of the New Testament epistles indicate incipient heresies, and the growth of error has always been rapid. It should be noticed that the correspondence with the Epistle of Jude is in the description of the false teachers (2 Pet. ii.).

It enunciates no specifically new teaching, breathes the spirit of the apostle whose name it bears, and furnishes a fitting valedictory of the venerable man who was awaiting the martyrdom predicted by his Master (John xxi. 18, 19). (M. B. R.)

PETERMANN, AUGUST (1822-1878), a German geographer, was born at Bleicherode, April 18, 1822. He was educated at Nordhausen and in 1839 entered the geographical institute at Potsdam, where he assisted in preparing Bergham's *Physical Atlas* and also prepared the maps of A. Von Humboldt's *Asie Centrale*. In 1845 he went to Edinburgh to superintend A. Keith Johnson's edition of the *Physical Atlas*. In 1847 he established himself in London, and contributed geographical articles to various publications. In 1854 he returned to Germany and took charge of Justus Perthes' geographical institute at Gotha. Here he founded his monthly *Mittheilungen*, which still remains the highest authority in current geographical literature. His activity was not confined to gathering, condensing, and criticising the researches of travellers. He directed and promoted the exploration of the less known parts of the earth, especially Africa and the Polar regions. His maps are of the highest excellence. In 1876 he visited the United States. He died by his own hand at Gotha, Sept. 25, 1878.

PETERS, CHRISTIAN AUGUST FRIEDRICH (1806-1880), a German astronomer, was born at Hamburg,

Sept. 7, 1806. In 1826 he was employed at the Altona Observatory, and in 1833 was made assistant at the Hamburg Observatory. In 1839 he took a similar position at Pulkowa near St. Petersburg. His valuable researches in regard to the motion of the fixed stars obtained for him admission to the St. Petersburg Academy. These investigations he continued to the end of his life. In 1849 he was made professor at Königsberg and in 1854 director of the Altona Observatory. Here also he became editor of the *Astronomische Nachrichten*, of which 58 volumes appeared under his direction. In 1872 the observatory was removed to Kiel, where Peters was made also professor in the university. Here he died May 8, 1880.

PETERS, CHRISTIAN HENRY FREDERICK, astronomer, was born at Coldenbüttel, Schleswig, Sept. 9, 1813. After graduating at the University of Berlin he was employed in astronomical work at Copenhagen and Göttingen. In 1838 he set out on scientific explorations which extended from Sicily to Palestine. In 1843 he was made astronomer at Naples, but having taken part in the revolutionary movement of 1848 he afterwards went to Constantinople. After the Crimean war he removed to the United States and was for a time connected with the Coast Survey. In 1858 he was made professor of mathematics and astronomy at Hamilton College, at Clinton, N. Y., where he took charge of the observatory, now called Litchfield Observatory. Some of his labors here have been noted under HAMILTON COLLEGE, to whose reputation he has greatly contributed. He also was prominent in the observation of the total solar eclipse of Aug. 7, 1869, at Des Moines, and had charge of the expedition sent to New Zealand by the U. S. government to observe the transit of Venus, Dec. 9, 1874. Owing to his skillful management his party was the only one which had entire success, having secured 237 photographs of the transit. He is widely known as a discoverer of asteroids.

His brother, WILHELM KARL HARTWIG PETERS (1815-1883), noted as a traveller and zoölogist, was born at Coldenbüttel, April 22, 1815. After studying medicine at Copenhagen and Berlin, he first investigated the fauna of the Mediterranean, and was appointed assistant to the Anatomical Institute at Berlin. In 1842 he went to Lisbon, and then undertook a scientific exploration of the Portuguese possessions in Africa. Returning to Berlin in 1848 he was made professor, afterwards professor extraordinary and in 1857 professor of zoölogy and director of the zoölogical collections. Under his care these were raised to the first rank. His chief work is *Naturwissenschaftliche Reise nach Mozambique* (5 vols., 1852-68). His contributions to comparative anatomy, philology, and the natural sciences were valuable. He died at Berlin, April 20, 1883.

PETERS, RICHARD (1744-1828), jurist, was born near Philadelphia, June 22, 1744. His father, William Peters, held several judicial offices. The son graduated at what is now the University of Pennsylvania in 1761, and was admitted to the bar in 1763. He commanded a company of provincial troops in 1775, and was made secretary of the Congressional Board of War in 1776. He detected and exposed Benedict Arnold's embezzlement of funds while in command at Philadelphia. In 1781 Peters resigned from the Board of War and was soon elected to Congress. He was afterwards speaker of the Pennsylvania Assembly and of the State Senate. In 1785 he visited England and assisted in securing the act of succession for the bishops of the Protestant Episcopal Church in America. In 1792 he was made judge of the U. S. District Court of Pennsylvania and held this office till his death, Aug. 22, 1828. He was noted as a wit and was a practical farmer. His country-seat at Belmont is now included in Fairmount Park, Philadelphia.

His son, RICHARD PETERS (1780-1848), was reporter of the U. S. Supreme Court for many years and pub-

lished 18 volumes of *Reports*, besides condensations and digests.

PETERS, SAMUEL ANDREW (1735-1826), commonly known as "Parson Peters," was born at Hebron, Conn., Dec. 12, 1735. He was a grandnephew of Hugh Peters, Cromwell's chaplain, for whom see the *ENCYCLOPEDIA BRITANNICA*. He graduated at Yale College in 1757, went to Europe and took orders in the Church of England in 1760. Returning to Connecticut he had charge of churches at Hartford and Hebron. During the agitation which preceded the revolution Peters offended his neighbors by the political letters he sent to England and New York. In 1774 he was rudely driven out and went to Boston and thence to England. His satirical *General History of Connecticut* (London, 1781) provoked loud remonstrance in that State. It has been republished several times and even defended as a sober history (see McCormick's edition, N. Y., 1877), though it seems more like the after-dinner talk of a spiteful humorist. It is the chief authority for the current fiction about the Connecticut Blue Laws. (See BLUE LAWS.) In 1794 Peters was chosen bishop of Vermont, accepted the office and wrote an episcopal letter to the churches, but was refused consecration by the Archbishop of Canterbury. He returned to America in 1805 and published a *History of the Rev. Hugh Peters* (1807), in which vanity, family pride, and his customary recklessness in regard to facts are strangely blended. At the age of eighty he made a journey to Minnesota to prosecute some land claims. He died in New York city, April 19, 1826.

PETERSBURG, a city of Virginia, in Dinwiddie county, is on the S. bank of the Appomattox River, 23 miles S. of Richmond. The falls of the river near by mark the head of tidewater and navigation, though flatboats are used above. Large vessels receive cargoes of tobacco at City Point at the mouth of the Appomattox, 12 miles below. Two railroads connect the city with Richmond, Norfolk, and other places. Petersburg has a court-house, government building (including custom-house and post-office), 6 banks besides savings banks, a daily and 3 weekly newspapers, 25 churches, several schools, both public and private, a theatre, and 2 public libraries. Its industrial works comprise foundries, cotton- and flour-mills, and tobacco-factories. The city is well built and has good natural drainage. It is lighted with gas and has water-works and a fine park. The town was laid out in 1733 by Col. William Byrd and was incorporated in 1748. During the revolutionary war it was twice occupied by British troops. During the second war with Great Britain it obtained the name "Cockade City," from the ardor of its volunteers. In the war of secession it attained still greater prominence, as it was the last stronghold of the Southern Confederacy. After the various attempts to reach Richmond from the north and east had failed, Gen. Grant, just after the battle of Cold Harbor (*q. v.*), determined to seize Petersburg. On June 12, 1864, the army of the Potomac crossed the James River below City Point, but the attack on the works was delayed until the 15th. Gen. W. F. Smith then succeeded in capturing some redans, and on the next day Generals Hancock and Meade captured more. But Gen. Beauregard, in command of the Confederates, maintained his hold of the city and strengthened its inner line of defences. The army of the Potomac now invested the city and the Weldon Railroad was torn up by cavalry. On June 25th Gen. Burnside, at the suggestion of Col. Pleasants, whose regiment was composed of Pennsylvania miners, authorized the construction of a mine under the enemy's works. The mine was ready July 23d, but the explosion was delayed until 5 A. M. on July 30, when it made a crater 100 ft. long and 20 ft. deep. The Union batteries began a vigorous cannonade and a division promptly entered the crater, but its cowardly commander left the troops to themselves, and most of their

were captured. The siege was prolonged until Grant resumed active operations against Lee's army in the following March. After Sheridan's victory at Five Forks, Lee saw that he must evacuate Petersburg, and Gen. Grant entered it on April 3d. The surrender at Appomattox followed on April 9th. Several years were required to restore Petersburg to its former prosperity, but its trade eventually increased beyond its former limits. Its population in 1880 was 21,656.

PETIGRU, JAMES LOUIS (1789-1863), the leading opponent of nullification in South Carolina, was born in Abbeville co., S. C., May 10, 1789. Graduating at Columbia College in 1809, he was admitted to the bar and became a prominent lawyer at Charleston. He adhered to the Federal party, and when the opposite views swept over the State and were pushed to their extreme in nullification and secession he remained faithful. His energy and eloquence did not avail to stem the tide, but he was called by the Legislature to codify the laws of the State. After the secession of the State he was engaged in this work, and completed it shortly before his death at Charleston, March 9, 1863.

PETITION, RIGHT OF. The right of petitioning the government, as existing in American political institutions, was derived from the system of England, where it had become established as an incident of the advance towards popular government, and passed into our colonial system, and thence into the Constitution of the United States and those of the States of the Union with little change. In the original frame of the Constitution of the United States no mention was made of the right of petition, but the First Amendment provides that Congress shall make no law abridging the right of the people peaceably to assemble, and to petition the government for a redress of grievances. Four States have substantially followed the form adopted in the Constitution of the United States as above given. In seven States the expression *redress of grievances* is omitted and the right is stated as that to petition, by address or remonstrance, the government or any department thereof. In one State it is to petition government on all matters, and in another to petition on any subject. In six States the object of petition is stated as the redress of grievances or other purposes. In sixteen States it is as follows: "to consult for the common good, to instruct representatives, and to petition the Legislature for redress of grievances."

The right of petition has commonly been associated with that of assembling for consultation as to matters of public interest, but never has been regarded as limited to the case of the transmission to the government of the results of popular deliberation in public assemblies, but on the contrary has been treated as an individual right as well as one appertaining to collective bodies of citizens. It will be observed that in the largest number of States the provision as to the redress of grievances is associated with one that secures to the citizen the right to instruct his representatives, and that in several of the States there is no definition of the subjects to which such petitions should relate, but the right is indefinitely extended by such expressions as, "other purposes," or "upon all matters," or "any subject."

While the right to make known one's grievances to the judicial branch of the government and to its executive officers is undoubtedly embraced in these constitutional provisions, the main object they had in view was to regulate the intercourse of the people with their representatives in the legislative body, for while the Legislature would, presumably, provide for the redress of the citizen, as it regarded the other branches of the government, the intercourse with that body was required to be placed under the protection of the constitution to which it was subject. At the present day the right of petition is understood as a right of the

citizen to make known to the legislative body his wants as an individual or as a member of the community.

Notwithstanding the fact that in representative popular governments the legislative body is habitually composed of the representatives of distinct geographical districts, that would suggest that the communication between the citizen and the Legislature should take place through the representative of the particular district of which such citizen is an inhabitant, still the right to communicate directly with the legislative body is habitually recognized, which is consistent with the idea that the Legislature acts as a unit, whatever may be the constitution of its parts.

In the United States the right of petition to legislative bodies has become so completely interwoven with the habits and ideas of the people that it has seldom been made the subject of discussion and criticism. Yet an instance has occurred in the history of the country where the right was involved in heated controversy. The right of petition to Congress was brought into question as involved with the anti-slavery agitation in the United States. It was conceded that Congress had no direct authority to control the condition of slavery within the States that composed the Union. Within the District of Columbia, the seat of government of the United States, embracing a very limited territory derived by cession from the States of Maryland and Virginia, slavery existed at the time of the cession and continued to exist as a legal institution until finally abolished as a consequence of the war of the rebellion. It was not seriously denied that Congress had authority to control the institution within that District, but the position was taken that it would be a breach of public faith to abolish slavery within that District while the States of Maryland and Virginia, from whom it was derived, still continued to maintain the institution. The question of the right of Congress to interfere to prohibit or limit the slave-trade between the States, and the introduction of slaves within the Territories of the United States for the purpose of holding them in slavery in such Territories, was debated from the standpoint of opposite views as to the construction of the Constitution of the United States. The controversy as to the proper construction of the Constitution turned upon the question whether the government of the United States was to be regarded as a sovereign national government, limited as to the subjects over which that sovereignty might be exercised, or whether it represented an aggregate of delegated powers that could not be enlarged beyond the particular subjects to which it was limited. The Supreme Court of the United States had adhered to the construction of these powers that rested upon the conception of a national sovereignty, but the adherents of slavery, the dominant party in Congress, still held doctrines that excluded Congress from all action relating to slavery, affecting its existence within the States, the Territories, or the District of Columbia.

The policy of the opponents of slavery centred upon the limitation and final abolition of slavery within the District of Columbia as a step preliminary to its ultimate extinguishment throughout the United States. With this end in view petitions were presented to Congress seeking the exercise of its powers to this end. These petitions asked that the slave-trade existing in the District should be abolished, that slavery in the District might be abolished, and for the adoption of a variety of public measures all tending to the ultimate extinguishment of slavery.

At first these petitions were respectfully received by Congress, but immediately laid upon the table without reference or consideration. In 1836 this considerate method of dealing with petitions of this class was deemed unsatisfactory by the friends of slavery and a more emphatic expression of disapprobation on the part of Congress of this line of agitation demanded. Mr. Calhoun, in the Senate, moved the rejection of a petition for the suppression of the slave-trade and the

emancipation of the slaves within the District upon the ground that Congress had no jurisdiction over the subject, but this motion was not carried. Respect for governmental forms, inseparable from free institutions, still continued to moderate the counsels of the majority of Congress, although in entire sympathy with the objects pursued by the friends of slavery.

The next step taken to defeat the objects of the petitioners was a resolution of the House of Representatives that all petitions relating to slavery in the District of Columbia should be referred to a select committee who should be instructed to report that Congress had no constitutional authority to interfere in any way with the institution of slavery in any of the States, and that it ought not so to interfere in the District, because it would be a violation of the public faith, unwise, impolitic, and dangerous to the Union, and whose duty it should be to furnish the reasons for such conclusions. The select committee was appointed and reported that all petitions, memorials, propositions, or papers relating in any way to the subject of slavery, or the abolition of slavery, should, without either being printed or referred, be laid upon the table. This report and resolution were adopted by an overwhelming vote. The following year, 1837, this resolution was in substance re-enacted by the House of Representatives. The next Congress affirmed and strengthened the position thus assumed, the House of Representatives resolving that all petitions, memorials, and papers touching the abolition of slavery, or the buying, selling, or transferring of slaves in any State, District, or Territory of the United States should be laid upon the table without being debated, printed, read, or referred, and that no further action whatever should be had thereon.

This action of the House of Representatives was regarded as needing explanation, and accordingly at a later period an explanatory resolution was adopted by the House of Representatives. The necessity for some explanation of the position assumed by the House was obvious. The people of the United States had been accustomed to regard the right of petition as an incident of representative popular government that was essential to its maintenance, and any aggression upon that right, when brought fully to the popular understanding, would tend to the injury of the cause in the interest of which it was undertaken. The slave policy could only be maintained by co-operation on the part of representatives whose constituencies had no direct interest in the institution of slavery, and, in the event that the choice had to be made between that institution and the dismemberment or crippling of the national government, would adhere to the Union although the destruction of slavery might be the consequence. Such considerations imposed upon the majority in Congress the necessity of placing their action in the most favorable light.

The explanatory resolutions denied the jurisdiction of Congress over the institution in the States and affirmed that the petitions introduced for the abolition of slavery in the District and against the removal of slaves from one State to another were part of a plan set on foot to affect the institution of slavery in the several States, and thus indirectly to destroy the institution within those States; that Congress cannot rightfully do that indirectly which it cannot do directly; that the agitation of the subject of slavery in the District or the Territories, with a view of disturbing or overthrowing that institution in the several States, was against the spirit and meaning of the Constitution and a breach of public faith; that the Constitution rests on the principle of equality among the States, and Congress had no right to discriminate for or against their respective institutions with the view of abolishing the one or promoting the other. These recitals were followed by a resolution declaring that all attempts on the part of Congress to abolish slavery in the District of Columbia or the Territories, or to discriminate be-

tween the institutions of the several States in the manner indicated in the foregoing recitals, are in violation of the Constitution, destructive of the fundamental principle on which the Union rests, and beyond the jurisdiction of Congress. It finally declares that any petition, memorial, proposition, or paper touching or relating in any way, to any extent whatever, to slavery or the abolition thereof, should on the presentation thereof, without any further action thereon, be laid upon the table without being debated, printed, or referred. The subsequent action upon petitions of this class went a step further, declaring that such petitions should not be received or entertained in any way whatever.

It is noticeable that the action of Congress that has been referred to proceeded step by step to unsettle and deny the right of petition to the national legislature as it regarded the subject of slavery in the United States, and exhibits a hesitation in taking the extreme ground that was ultimately reached upon that subject. At first it seemed sufficient to lay all petitions on that subject upon the table, thus recognizing the right of their presentation and the duty of their reception, but giving expression to the disapprobation of Congress of the measures propounded by such petitions. The next step was that they should not be printed or referred, but at once be laid upon the table, still leaving the duty of receiving them admitted, but providing that they should neither be brought into consideration nor disseminated by printing. A further step was that they should not be read, thus closing the ears of Congress, as a legislative body, to matters deemed of great public importance by large bodies of the people whom that body had assumed to represent. It only remained to declare that such petitions should not be received to complete the denial of a fundamental tenet of liberty, and that step was at last taken.

The history of the events thus briefly stated is of interest not only in characterizing the nature and tendencies of the institution of slavery in its effect upon the principles of liberal government, but as exposing dangers that may at any time threaten the right of petition when material interests are sufficiently strong and opposed to the principles of social order. That right is in effect the right of communication between the sovereign people of a representative popular government and the persons selected by them to embody their convictions and desires in public laws, and cannot be denied without subverting the proper relations between the public authority and the agents for its exercise. Assume a state of things in which the majority of the people of a popular government concur in a certain line of policy, or of opinion as to the effect of certain laws, and the immediate representatives of that majority refuse to give attention to the representations of the minority, and a case is presented that contradicts the principles upon which not only popular representation in government depends but the very security of popular liberty. Should the representatives of the people misapprehend or intentionally disregard the sentiments or interests of the majority of the people they represent, to affirm that such majority may be excluded from presenting such sentiments and interests directly and formally to the body assuming to represent it, is to contradict the plainest dictates of common sense. It is equally unreasonable that a minority of the people should be excluded from formal communication to the representative body, for rational government implies a comparison of opposite and divergent opinions, and to shut out any respectable body of opinion is to destroy the balance of the system. It may be said that the right of petition has lost much of its importance since the policy of frequent elections of representatives has been adopted, and that the elective act covers all that was intended to be secured under the right of petition. Such a suggestion is in harmony with the existing tendency to replace rational methods by technical devices, and is not strengthened by what

appears in the development of the elective system in this country and elsewhere. The election is means of selecting an agent, while the right of communicating with the legislative body is means of directing that agent in the discharge of his duty. To affirm that the right to select an agent tends to displace the right to direct him when selected, is neither consonant with logic or common sense. The tendency of the elective system in highly composite communities and governments appears to be in the direction of integrating the material interests of the community in the formation of a public policy with especial reference to some exigency in public affairs that for the time being displaces other interests however important. Public agents selected with reference to a particular exigency, and as the exponents of a particular policy, especially when that policy is based on material interests, are likely to need all available modes of communication with their constituencies in order to know the state of opinion and feeling on other than material interests.

The press has important functions in keeping in mind the aspirations and wishes of the people, but represents public opinion in an indirect and reflex way only, while the petition, memorial, and remonstrance to the legislative body may be made, and commonly are made, the vehicle of collective opinion and sentiment. If the morals and humanity of a community ought to have any place in an organized system of legislation, that place must be assigned in the means of communication between the legislative body and collective bodies of citizens. The right of petition thus stands as the exponent of the conscience and aspirations of the community as well as of its neglected interests, material and social.

Assuming then that there is reason for maintaining the right of petition, as essential to sustaining the proper relations between the agents of government and the governed, and the effect upon that right of the action induced by the slavery agitation is of practical importance. It is evident that right was denied, at first in substance and afterwards in form, to those who sought to express their convictions as to the social character of slavery to Congress. That denial took place on two grounds: first, that Congress was asked to do that which it had no authority to do; and, second, that what was sought would occasion a breach of the public faith pledged to the States of the Union that sustained the institution of slavery. That Congress had authority to act on the representations made to it of the social evils arising from slavery, even in the States, cannot be denied with any reason. If it appeared to Congress that the institution of slavery as it existed in the States was detrimental to the interests of the whole Union, it had authority under the Constitution to frame articles of amendment to the Constitution to be submitted to the States for ratification, which if receiving the assent of three-fourths of the States would become part of the Constitution and would be competent to inhibit slavery within the States. Whether the case presented by the petitions on the subject of slavery was such as to call for the exercise of that power was a question for consideration by Congress, and if it had the right to consider that subject it was its duty to receive petitions in relation to it.

Placing the impropriety of the consideration of what was asked by the petitions upon the ground that it would be a breach of public faith to the slave States was virtually admitting that Congress possessed the power of prohibiting slavery in the District of Columbia and the Territories. The affirmation here implied is that wherever there is a governmental policy that, in the opinion of a portion of the people and of the States, is necessary to be maintained on the ground of public faith, the residue of the people and States shall not be permitted to oppose that conclusion by means of the right of petition. Bald as such a ground would be it is stronger than the case actually stated. It was

not claimed that attention to the representations of the opponents of slavery would directly operate as a breach of the public faith, but that it would indirectly have that effect. The ground taken was that the agitation of the question of the abolition of slavery endangered the institution, although in what form that danger was to be realized was not stated among the reasons given for the action of Congress. The exclusion of the petitions was based upon a purpose to suppress the agitation of the slave question, which means the suppression of the right of public discussion of the bearing of public measures. It was not claimed at that day that the methods of agitation implied anything beyond popular discussion, and, therefore, agitation meant discussion and nothing more. The question is resolved to the simple inquiry whether the right of petition may with propriety be denied as a means of suppressing discussions on public questions where such discussion may possibly, in some indirect way, entail changes on the condition of some section of the country by which it is regarded as undesirable, and in this form of statement needs no elucidation. It is a noticeable fact that the States that took part, through their representatives, in this effort to suppress the freedom of discussion of public affairs are the same States that vehemently opposed the Alien and Sedition laws upon the ground that they sought to suppress the freedom of speech and of the press.

The action of the House of Representatives in thus refusing to receive petitions coming from the people of the United States must be weighed by the provisions of the first article of amendment of the Constitution of the United States, which declares the right of the people peaceably to assemble and petition the government for a redress of grievances. The term "grievances," as here used, was borrowed from the history of early times when the people having no hand in making the laws, if aggrieved by laws unsuited to their condition and wants, assumed the attitude of supplicants to the law-making authority for that which they deemed to be for their good, and the subjects of their requests were termed grievances where they complained of bad laws or asked the enactment of good ones. With the progress of liberal ideas this privilege of communicating with the law-making power came to be recognized as a right that might be claimed under the principles determining the nature and sanctions of government as adjusted to the needs of social man. Still further progress in the right understanding of governmental principles found the right derived from the fact that the people were the source of all public authority, which could not exist without their authorization or permission, and therefore were entitled to make known their desires to those who were intrusted with the formation of laws.

The Bill of Rights, which is a fixed feature of all the American constitutions and was derived from the institutions and ideas of England, as the product of popular revolution in that country, perpetuates the right of petition as a fundamental right incident to the relations between the agents of government and the people. By comparing together the various forms in which this right is recognized in the constitutions of the various States and comparing them with the Constitution of the United States, it is made clear that the term grievances is used in no narrow or technical sense but as comprehending all that may be within the authority of the law-making power to promote the well-being of the citizen.

It has never been supposed that a legislative body deriving its powers from a written constitution embodying the Bill of Rights, as the expression of the principles of liberty that should be the foundation of all governmental authority exercisable, could decline to exercise the powers enjoined by it or do that which it prohibits for any prudential reason whatever without an infraction of the obligations imposed by it. Where one clause of the bill secures the right of popular dis-

cussion and another that of petition to the legislative body the boldest conceivable infraction of its requirements would be where the right of petition was denied for the purpose of stifling public discussion. The right of petition as stated from its historic and constitutional sources implies that appeal to the reason of man can never be detrimental to the true interests of government or society, although appeals to popular passion, that are less apt to attract attention and receive restraint, may entail the greatest evils upon governments and communities.

See Greeley's *American Conflict*; J. Q. Adams's *Speeches in Congressional Globe* (1837-42), and SLAVERY in this work.

(A. J. W.)

PÉTOFI, SANDOR or ALEXANDER (1822-1849), a Hungarian poet, was born at Kis-körös, Dec. 31, 1822. He was sent to various schools, but his restless disposition led him to become a soldier and then a strolling player. In 1843 his poems in the newspapers attracted notice, and soon a collection of them appeared. They depicted the light and shade of peasant life, and he has been well called the Robert Burns of Hungary. Among his noted productions are *The Hammer of the Village* (1844); the epic *Hero Janos* (1845); the drama, *Tiger and Hyena* (1846), and several novels. In 1848 he led the young men of Pesth in the movement for Hungarian independence, to which his national songs powerfully contributed. He was afterwards adjutant to Gen. Bem, and in the battle of Segesvar, July 31, 1849, he was seen for the last time. In 1882 a statue of him by Huszar was erected in Budapest. His poems were translated into English by Sir J. Bowring (1866), and there have been many German translations.

PETROLEUM. This industry, during the years 1883 to 1888, has undergone numerous and important changes. It was during this period that the vast accumulations reached their highest, the stocks in the tanks and pipe-lines during the year 1884 reaching a total of 40,000,000 barrels. The total production of crude petroleum during the same year was about 25,000,000 barrels, nearly 2,000,000 barrels of which were added to the already burdensome supply above ground. Drilling operations continued unchecked and it became a serious question what disposition could be made of the oil. During the summer of 1887 the producers organized under the name of the Producers' Protective Association, for the purpose of restricting the production of oil and to restrict the drilling of new wells. As the average cost of oil to the producer is \$1.17 per barrel, such a course was considered absolutely necessary to prevent a continuance of serious losses. The plan adopted contemplated the reduction of production fully 17,000 barrels per day, and it was believed that this course would in a short time bring about such a change in the statistical situation that the market price of crude oil would advance and in future insure a profit to the producer. The term of this agreement was one year from November 1, 1887. Under this agreement the production was restricted and drilling operations were suspended. Stocks were reduced an average of fully 600,000 barrels per month, but the price of the product did not show the improvement that was hoped for, owing to speculative operations on the several exchanges. There was, nevertheless, an improvement in the price, and the full effects of the movement were beginning to be manifest as the term of what became popularly known as "the shut-down agreement" neared its close.

The most prolific oil-field yet developed is what is known as the Bradford field, which lies in the upper part of McKean co., Pa., and occupies a small portion of Cattaraugus co., N. Y. This field has produced a total of 150,000,000 barrels of crude petroleum during the past twenty years. The greatest production was in the year 1881, when the enormous total

of 23,000,000 barrels was reached. During the month of August of that year the average daily production exceeded 80,000 barrels, but in December the production had declined to an average of 70,000 barrels per day. The number of wells drilled in this field during the year 1882 reached 3,803, and the total number since oil was first discovered in that prolific territory is fully 16,000, about 10 per cent. of which were unproductive. The rise and decline in the production of this field is a fair illustration of the whole producing area of the States of Pennsylvania and New York, although some of the fields show a more steady production. The production of the Bradford field in 1887 had declined to 7,700,000 barrels. The maximum daily production of the Allegheny field was 24,000 barrels in July, 1882; that of the Washington field was 18,000 barrels in September, 1886; of Cherry Grove, 40,000 barrels in August, 1882; of Thorn Creek, 15,600 barrels in November, 1884. These fields have played an important part in the history of petroleum, although others of smaller production exerted an influence on the speculative market altogether out of proportion to their importance. Venango county, where oil was first pumped by Col. E. L. Drake in 1859, has produced about 60,000,000 barrels. Butler and Clarion counties have together produced about 70,000,000 barrels. These comprise the principal fields from which comes the oil that produces the burning oil, or kerosene, of commerce.

The oil district known as the Franklin field produces an oil distinct in character and one which is not taken into account in the statistics of production of the Pennsylvania fields. It is a heavy oil of low cold test which is used for the manufacture of superior grades of lubricating oil. Its average price is about \$4 per barrel at the wells. The wells in this field produce less than 10,000 barrels per month, the average per well not exceeding one-half barrel per day. The wells in West Virginia also produce an oil of a heavy gravity used exclusively in the manufacture of superior grades of lubricating oils. The product of these fields is not counted in the tables giving the statistics of production, consumption, stocks, etc. Important discoveries of petroleum have also been made in Wyoming Territory and in several of the Southern States, and it is believed that petroleum may be found in nearly every State. The wells in California produce oil of a quality similar to the Bradford oil and in quantity sufficient to supply the requirements of the entire Pacific coast of the United States.

The oil-fields of Ohio have been developed since 1885 and pipe-lines have been laid and immense storage tanks erected. The oil is inferior to that from the wells in Pennsylvania, but the wells are more prolific and the producers continue to drill wells though the price realized for the product is only 15 cents per barrel. The principal fields in this State are in the vicinity of the city of Lima, and in North Baltimore, Wood county. The Ohio oil, owing to its low cost, is used as fuel to generate steam in the burning of brick and in some metallurgical operations. It has been found more economical than coal and its use as fuel is extending. A pipe-line has been constructed from the Lima field to the city of Chicago, which has a capacity for supplying that city with 9000 barrels daily of the liquid fuel. The transport of petroleum was formerly confined to railway vessels, but the fear from explosion has been found to be groundless and steamships are now regularly engaged in carrying both crude and refined petroleum. Steamships and sailing vessels have been constructed to carry petroleum in bulk. In their hulls are fitted iron tanks which occupy the entire space between decks, into which the oil is pumped direct from the reservoirs at the refineries. Arriving at its destination, the ship is unloaded by powerful steam-pumps in one-fifth of the time required to unload a vessel of similar size loaded with the oil in barrels.

Market Value.—The price of crude petroleum has varied greatly. The highest price realized was \$20 per barrel during the first five months following the date of drilling the first well by Col. Drake in 1859. The production, however, soon exceeded the demand, and there being at that time but imperfect facilities for storage, the price declined rapidly and reached the lowest point in November, 1861, when oil was sold at the wells at 5 cents per barrel. As improved methods for refining the oil were invented the demand increased and the price advanced, reaching \$14 per barrel in July, 1864. This was in the early history of the industry. During the last eight years, while the fluctuations have at times been sudden, the range of prices has been within narrower limits and values have been for the most part governed by the usual trade conditions. Speculation on the petroleum exchanges has at times governed prices and caused depression in values despite decreasing stocks, increasing consumption, and restricted production. Thus, during the first half of the year 1888 the price of crude petroleum has averaged lower than during the year when the stocks were largest and the production much larger. Table I. gives the highest and lowest prices per barrel of 42 gallons in each year, and the month when such prices obtained :

TABLE I.—Highest and Lowest Price.

Year.	Month.	Highest.	Month.	Lowest.
1859.....	September.....	\$20.00	September.....	\$19.50
1860.....	January.....	20.00	December.....	2.00

Year.	Month.	Highest.	Month.	Lowest.
1861.....	January.....	1.75	November.....	.05
1862.....	October.....	2.00	January.....	.10
1863.....	December.....	4.00	January.....	2.00
1864.....	July.....	14.00	February.....	3.75
1865.....	January.....	10.00	August.....	4.00
1866.....	January.....	5.00	December.....	1.65
1867.....	September.....	4.00	June.....	1.50
1868.....	July.....	5.50	January.....	1.80
1869.....	January.....	7.00	December.....	4.25
1870.....	January.....	4.90	August.....	2.75
1871.....	June.....	5.15	January.....	3.40
1872.....	June.....	4.10	September.....	3.00
1873.....	January.....	3.05	December.....	1.00
1874.....	April.....	1.90	December.....	.45
1875.....	April.....	1.65	January.....	.90
1876.....	December.....	4.23½	January.....	1.48½
1877.....	January.....	3.70	June.....	1.53½
1878.....	February.....	1.86½	September.....	.78½
1879.....	December.....	1.28½	June.....	.63½
1880.....	June.....	1.24½	April.....	.70½
1881.....	September.....	1.01½	July.....	.72½
1882.....	November.....	1.36	July.....	.49½
1883.....	June.....	1.24	January.....	.83½
1884.....	January.....	1.15½	June.....	.50½
1885.....	October.....	1.12½	January.....	.68
1886.....	January.....	.91½	August.....	.59½
1887.....	July.....	.54	December.....	.90½
1888.....	March.....	1.00	June.....	.72

Table II. gives the average market price of crude petroleum, in barrels of 42 gals., for each month since petroleum became a marketable commodity, also the average price for each year :

TABLE II.—Monthly and Yearly Average Prices.

Year.	Jan.	Feb.	March.	April.	May.	June.	July.	August.	Sept.	Oct.	Nov.	Dec.	Yearly.
1859.....									20.00	20.00	20.00	20.00	20.00
1860.....	19.25	18.00	12.62½	11.00	10.00	9.50	8.62½	7.50	6.62½	5.50	2.75	2.75	9.60½
1861.....	1.00	1.00	1.00	62½	50	50	50	25	20	10	10	10	4.80½
1862.....	10	15	22½	50	85	1.00	1.25	1.25	1.25	1.75	2.25	2.25	1.07
1863.....	2.25	2.50	2.62½	2.87½	2.87½	3.00	3.25	3.37½	3.50	3.75	3.85	3.95	3.15
1864.....	4.09	4.37½	5.50	6.56	6.87½	9.50	12.12½	10.12½	8.75	7.75	10.00	11.00	9.15½
1865.....	8.25	7.50	6.00	5.00	7.37½	5.62½	5.12½	4.62½	6.75	5.12½	7.25	6.50	6.87
1866.....	4.50	4.40	3.75	3.95	4.50	3.87½	3.00	3.75	4.50	3.39	3.10	2.12½	3.59
1867.....	1.87½	1.85	1.75	2.07½	2.35	1.90	2.62½	3.15	3.40	3.55	2.50	1.87½	2.74
1868.....	1.95	2.00	2.53	2.82	3.76	4.50	5.12½	4.57½	4.00	4.12½	3.75	4.35	3.41½
1869.....	5.75	6.95	6.00	5.70½	5.35	4.95	5.37½	5.57½	5.50	5.50	5.80	5.12½	5.63½
1870.....	4.52½	4.52½	4.15	4.21½	4.40	4.17½	3.77½	3.15	3.25	3.27½	3.22½	3.40	3.89
1871.....	3.82½	4.34	4.25	4.01	4.60	3.85½	4.79	4.66	4.65	4.82½	4.25	4.00	4.34
1872.....	4.92½	3.80	3.72½	3.52½	3.80	3.85	3.80	3.58½	3.25	3.15	3.83½	3.32½	3.64
1873.....	2.60	2.20	2.12½	2.30	2.47½	2.22½	2.00	1.42½	1.15	1.20	1.25	1.00	1.83
1874.....	1.20	1.40	1.60	1.90	1.62½	1.32½	1.02½	.95	.95	.85	.55	.61½	1.17
1875.....	1.03	1.32½	1.75	1.36½	1.40	1.26½	1.09	1.13	1.33	1.32½	1.44	1.55	1.35
1876.....	1.80	2.00	2.01	2.02½	1.90½	2.01½	2.24½	2.71	3.81	3.37½	3.11	3.73	2.56½
1877.....	3.59½	2.70	2.67½	2.58	2.24	1.94½	2.07½	2.51	2.38	2.56½	1.91	1.80	2.42
1878.....	1.43	1.65½	1.59	1.37½	1.35½	1.14	.98½	1.01½	.86½	.82½	.89½	1.16	1.19
1879.....	1.03	.98	.86½	.78½	.76	.68½	.69½	.67½	.69½	.82½	1.06½	1.18½	.85½
1880.....	1.10½	1.03½	.88½	.78	.80	1.00	1.06½	.91	.96	.96½	.91½	.91½	.94½
1881.....	.95½	.90½	.83½	.863½	.81	.81½	.76½	.78½	.93	.94	.83	.84	.85½
1882.....	.63½	.85½	.807½	.74½	.69½	.68	.56½	.58½	.74	.94	1.27½	1.11½	.81
1883.....	.92½	1.00½	.98½	.92½	1.03	1.18½	1.07½	1.08½	1.13	1.11½	1.15	1.14½	1.06½
1884.....	1.11	1.06	1.01½	.95	.86½	.87	.77	.90	.79	.70½	.72½	.74½	.91½
1885.....	.707½	.87½	.80	.79½	.79	.82	.96½	1.00½	.90½	1.05½	1.04½	.89½	.88½
1886.....	.88½	.78½	.77½	.74½	.69½	.66½	.66½	.62½	.63½	.65½	.71½	.70½	.71
1887.....	.70½	.64½	.63½	.64½	.64½	.62½	.59½	.60½	.67	.70½	.73½	.81	.66½
1888.....	.91½	.90½	.93½	.82½	.86½	.75½	.79½	.87½	.93½	.90½			

Wells Drilling.—Owing to various causes the number of wells in process of drilling has varied greatly from year to year and from month to month. The

discovery of a new field or pool has always stimulated new drilling ventures, while declining production and continued failures have at other times tended to re-

TABLE III.—Wells Drilling.

Year.	Jan.	Feb.	March.	April.	May.	June.	July.	August.	Sept.	Oct.	Nov.	Dec.	Average.
1876.....	142	151	230	267	307	340	353	374	511	565	618	493	363
1877.....	457	463	395	448	512	395	365	417	535	573	565	426	463
1878.....	334	326	379	409	376	266	188	185	240	282	297	218	292
1879.....	265	323	406	468	460	384	329	258	270	313	372	440	357
1880.....	540	535	577	580	460	440	452	515	491	469	475	478	495
1881.....	383	420	437	446	470	408	379	352	388	445	475	468	423
1882.....	422	438	408	405	351	226	240	194	177	184	154	138	276
1883.....	126	151	205	199	216	228	262	315	314	341	301	263	243
1884.....	270	273	260	284	244	123	123	91	79	100	86	78	168
1885.....	97	109	139	190	228	209	242	308	391	355	359	277	242
1886.....	320	337	356	318	358	403	349	290	322	312	285	238	324
1887.....	201	177	155	155	157	142	135	137	107	104	114	88	139
1888.....	64	72	83	59	82	106	124	106	166				

strict operations in untried fields. The largest number of new wells drilling was 618, in November, 1876, and the smallest number was 33, in March, 1888. The large decrease in new work during 1887 was due to the low price of the product, and during 1888 to an agreement between the producers to restrict operations, with the object of reducing the stocks. The number of wells being drilled at the end of each month in the years 1876 to 1888 is given in Table III.

Wells Drilled.—The largest number of wells completed in any month was 470, in May, 1878, and the

smallest number 49, in April, 1888. The largest number completed in any year was 4217, in 1880, and the smallest number since 1875 was 1644, in 1887. The year 1888 will show a further decrease, owing to the suspension of drilling operations pursuant to an agreement among the producers entered into in the summer of 1887, and which was to continue from Nov. 1, 1887, to Oct. 31, 1888.

The number of wells completed in each month during the years 1870 to 1888, and the total for each year, are given in Table IV. :

TABLE IV.—*New Wells Completed.*

Year.	Jan.	Feb.	March.	April.	May.	June.	July.	August.	Sept.	Oct.	Nov.	Dec.	Total.
1870.....	131	131	114	135	164	182	161	156	135	144	112	78	1,644
1871.....	98	68	70	81	95	150	139	116	125	180	161	181	1,470
1872.....	48	118	98	122	130	98	131	117	96	101	41	101	1,201
1873.....	100	105	105	110	106	180	112	116	116	111	108	95	1,364
1874.....	108	111	108	110	112	113	124	102	108	117	112	116	1,341
1875.....	184	186	194	180	169	194	208	206	208	215	213	228	2,385
1876.....	240	231	242	200	202	261	248	270	209	273	272	272	2,920
1877.....	281	241	291	269	320	403	317	255	322	467	391	382	3,939
1878.....	274	226	211	409	470	269	203	186	174	229	248	165	3,064
1879.....	136	132	248	270	402	330	327	283	210	232	227	261	3,048
1880.....	320	230	367	500	426	310	338	368	356	364	356	302	4,217
1881.....	222	220	271	316	406	374	336	332	312	322	363	406	3,380
1882.....	347	340	385	432	469	340	185	253	164	117	150	122	3,304
1883.....	125	126	142	209	231	228	261	309	321	321	302	272	2,847
1884.....	229	209	256	293	311	244	268	145	89	59	73	66	2,247
1885.....	64	62	82	116	213	242	217	283	356	397	384	345	2,761
1886.....	270	280	291	328	343	365	357	317	253	272	221	185	8,482
1887.....	158	162	138	160	148	157	159	142	134	100	90	96	1,644
1888.....	57	52	66	49	66	97	82	96	132	229			

Producing Wells.—The number of producing wells shows an almost unbroken increase from year to year to 1886 when the number reached 24,726. During 1888 there was a decrease of 1109 from the total of the previous year, but the year following showed a large increase. The largest number of producing wells at any time was 25,593, in February, 1887. Since Octo-

ber, 1887, the decrease has been fully 8000, showing the effect of the suspension of drilling operations, and the fact that a large proportion of the wells soon cease to be productive. Table V. gives the number of producing wells at the close of each month in the years 1876 to 1888, with the yearly average :

TABLE V.—*Producing Wells.*

Year.	Jan.	Feb.	March.	April.	May.	June.	July.	August.	Sept.	Oct.	Nov.	Dec.	Average.
1876.....	3,314	3,638	3,670	3,772	3,930	4,627	4,774	6,047	5,285	6,552	6,809	6,000	4,685
1877.....	6,283	6,441	6,666	6,846	7,037	7,352	7,567	7,684	7,872	8,061	8,323	8,458	7,383
1878.....	8,616	8,725	8,848	9,711	9,400	9,605	9,776	9,884	10,012	10,188	10,276	10,337	9,561
1879.....	10,482	10,582	10,692	10,782	11,045	11,223	11,461	11,585	11,760	11,860	11,960	11,960	11,283
1880.....	12,000	12,072	12,222	12,572	12,972	13,172	13,275	13,500	13,825	14,100	14,400	14,700	13,234
1881.....	14,900	15,050	15,500	15,769	16,150	16,300	17,000	17,250	17,562	17,799	18,040	18,300	16,668
1882.....	18,400	18,600	18,850	19,150	19,350	19,500	19,570	19,600	19,600	19,900	18,700	18,000	19,027
1883.....	17,600	17,300	17,250	17,100	17,100	17,050	17,100	17,100	17,300	19,100	20,400	20,600	17,918
1884.....	20,750	20,930	21,000	21,242	21,434	21,658	21,844	21,916	21,900	21,859	21,859	21,909	21,526
1885.....	21,950	21,987	22,012	22,093	22,233	22,384	22,524	22,688	22,776	23,062	23,295	23,519	22,646
1886.....	21,899	21,865	24,034	24,269	24,533	24,797	25,030	25,120	25,243	25,303	25,381	25,443	24,726
1887.....	25,618	25,593	25,472	25,268	25,173	25,057	25,035	25,003	24,892	24,831	16,723	16,637	23,767
1888.....	16,271	16,483	16,271	15,722	15,719	15,861	16,972	16,169	20,250	21,371			

Production.—The production of petroleum in the Pennsylvania and New York oil-fields has varied considerably from month to month, but there was a gradual increase from 1861, when the industry began to assume important proportions, until 1876. During the following year the industry made great strides, and each succeeding year showed a large increase in the production until 1882, in which year the maximum was reached, since which time there has been a decline. The yearly gross production in barrels and daily average from 1859 to 1875 inclusive are given in Table VI. :

TABLE VI.—*Yearly Production and Daily Average.*

Year.	Total bbls.	Daily av'ge.	Year.	Total bbls.	Daily av'ge.
1859.....	2,000	224	1868.....	3,715,741	10,180
1860.....	500,000	1,369	1869.....	4,186,475	11,469
1861.....	2,113,600	5,790	1870.....	5,308,046	14,542
1862.....	3,056,606	8,377	1871.....	5,278,072	14,460
1863.....	2,611,359	7,154	1872.....	6,505,774	17,824
1864.....	2,116,182	5,797	1873.....	9,849,508	26,984
1865.....	3,497,712	9,583	1874.....	11,102,114	30,416
1866.....	3,597,527	9,856	1875.....	8,948,749	24,517
1867.....	3,347,306	9,143			

Beginning with the year 1876 the yearly increase was unbroken until 1883, since which there has been considerable variation in the production, due to various causes, mainly, however, to the decline in the productiveness of many of the wells and the exhaustion of pools, as small fields are termed. The discovery of flowing wells in new territory has proven a greater incentive to the producers than has an advance in the market price of the product. Such a discovery has always stimulated drilling operations, resulting in a large increase in the number of new wells. If the new wells prove productive, it indicates the discovery of a new pool or field, according to the extent of the productive area. The determination of the extent of a new field sometimes results disastrously to the drillers as territory, but a few rods from a good well may, and often does, prove unproductive. The remarkable decrease shown in the returns for 1888 is due to the restrictions agreed upon by the producers, as already mentioned. Table VII. gives the average daily production, in barrels of 42 gals., during each month in the years 1876 to 1888 inclusive :

TABLE VII.—Average Daily Production.

Year.	Jan.	Feb.	March.	April.	May.	June.	July.	August.	Sept.	Oct.	Nov.	Dec.	Average.
1876.....	22,975	23,065	23,167	23,383	23,721	24,120	24,633	25,233	26,020	26,102	26,218	25,390	24,502
1877.....	27,190	27,979	29,087	32,427	36,374	37,693	38,355	41,089	40,497	40,946	39,114	40,618	35,939
1878.....	38,816	39,102	38,980	39,863	40,802	40,675	41,415	43,288	43,857	44,187	44,965	42,538	41,632
1879.....	44,190	43,515	48,365	51,015	53,062	55,855	56,057	61,042	61,890	59,238	67,018	57,076	54,027
1880.....	61,423	64,552	65,032	67,190	71,901	71,948	72,530	75,517	78,210	76,956	75,814	72,214	71,107
1881.....	72,350	68,326	73,372	73,526	77,203	79,262	76,538	75,217	73,114	74,941	75,561	80,000	74,954
1882.....	75,921	76,119	80,070	80,093	80,212	84,198	105,102	100,145	87,346	74,118	73,098	81,210	82,303
1883.....	62,849	62,721	59,052	60,551	63,292	65,930	65,174	60,267	63,779	66,989	65,278	64,146	63,336
1884.....	58,898	64,850	66,207	68,862	72,013	62,073	66,450	67,715	64,942	63,286	60,390	58,794	67,684
1885.....	53,298	61,353	52,843	59,343	57,141	58,907	57,284	55,031	57,093	60,455	58,722	61,247	58,921
1886.....	56,418	57,316	62,298	64,612	70,283	77,846	78,031	78,426	80,618	77,681	74,093	70,375	70,729
1887.....	64,221	65,283	64,716	65,372	64,307	63,782	61,275	69,641	59,321	61,822	37,515	41,568	59,067
1888.....	38,271	45,893	41,918	45,722	49,478	50,752	47,290	67,379	44,691	45,272			

Consumption.—The consumption of petroleum has increased steadily, and, while it did not keep pace with the enormous increase in the production from 1876 to 1882, there has been no check to the increase since then, while the declining production has caused a corresponding decrease in the stocks held in tanks and pipe-lines. The average yearly consumption may be given as

26,000,000 barrels, fully three-fifths of which is exported as crude oil and its products, principally illuminating oil. Table VIII. gives the monthly shipments of petroleum from the oil regions of Pennsylvania and New York. These shipments are accepted as representing the consumption during the years 1876 to 1888 inclusive:

TABLE VIII.—Monthly and Yearly Consumption.

Month.	1876.	1877.	1878.	1879.	1880.	1881.
January.....	677,289	743,461	775,791	663,998	1,650,409	1,061,616
February.....	519,193	484,904	774,234	702,729	395,151	916,028
March.....	623,762	913,919	741,512	973,879	1,613,371	1,276,740
April.....	603,087	903,625	846,632	1,136,188	842,268	1,348,398
May.....	646,150	1,234,324	960,894	1,331,469	1,095,259	1,563,436
June.....	921,862	1,391,124	1,135,119	1,369,314	975,083	1,729,897
July.....	1,228,539	1,096,951	1,330,454	1,625,035	1,231,611	1,925,532
August.....	1,203,402	1,425,943	1,655,651	1,908,239	1,394,129	2,214,877
September.....	1,154,549	1,563,797	1,434,225	1,627,120	1,252,635	2,131,950
October.....	524,190	1,268,971	1,747,390	1,662,269	1,665,933	2,080,467
November.....	671,496	1,205,634	1,281,410	1,453,645	1,226,030	2,068,906
December.....	1,190,983	600,019	992,688	1,532,585	1,335,613	1,969,581
Total.....	10,161,452	12,832,573	13,676,000	15,896,470	15,677,492	20,284,235

Month.	1882.	1883.	1884.	1885.	1886.	1887.	1888.
January.....	1,657,067	1,357,816	1,686,961	1,804,028	1,991,561	2,312,067	2,285,109
February.....	1,787,909	1,250,824	1,723,261	2,895,021	1,032,704	1,995,757	2,163,967
March.....	1,718,956	1,641,899	1,873,890	1,887,034	2,055,730	2,332,324	1,979,753
April.....	1,678,134	1,908,379	1,643,336	1,823,726	2,070,468	1,938,278	1,928,435
May.....	1,827,356	1,995,634	1,899,329	2,007,090	2,032,672	2,328,564	1,773,994
June.....	2,172,685	1,747,789	1,827,555	2,034,025	2,117,489	2,165,439	1,956,115
July.....	2,402,970	1,634,407	1,740,921	1,961,152	2,418,991	2,000,173	2,008,531
August.....	2,047,545	2,066,478	2,000,371	2,049,099	2,059,299	2,220,768	2,223,263
September.....	1,992,171	2,325,574	2,292,087	2,116,659	2,167,323	2,342,227	2,289,486
October.....	2,089,428	2,215,421	2,510,283	2,060,150	2,441,848	2,673,008	2,568,115
November.....	1,404,640	2,065,602	2,078,261	1,857,080	2,724,796	2,462,082	
December.....	1,121,453	1,749,547	2,382,244	2,138,253	2,550,891	2,608,341	
Total.....	21,900,314	21,979,369	23,657,599	23,713,326	26,653,832	27,279,028	

Stocks.—Previous to 1870 there were no important accumulations of crude petroleum, and the total stocks at the end of 1873 had reached only 1,625,157 barrels. At the end of 1874 there had been an increase to 3,705,639 barrels, but at the end of 1875 this had been decreased to 2,751,758 barrels. During the next two years there was little change, but from 1878 the increase was almost unchecked until the maximum of nearly 40,000,000 barrels was reached during 1885. The

accumulations had become burdensome, and the immense iron tanks of the various storage and pipe-line companies were taxed to their utmost capacity. Since August, 1885, there has been a gradual decline in the stocks, which during these three years has amounted to about 18,000,000 barrels. Table IX. gives the amount of crude petroleum, in barrels, in tanks and pipe-lines at the close of each month in the years 1876 to 1888 and the yearly average:

TABLE IX.—Stock of Crude Petroleum.

Month.	1876.	1877.	1878.	1879.	1880.	1881.
January.....	3,585,143	2,604,128	3,555,342	6,321,222	8,724,194	20,110,903
February.....	3,734,835	2,880,638	8,875,964	6,813,663	9,204,062	21,108,903
March.....	3,829,250	3,210,454	4,342,832	6,318,099	9,606,683	22,105,789
April.....	8,900,703	3,279,731	4,892,090	7,689,111	10,780,153	22,963,171
May.....	8,989,904	3,173,008	4,998,058	6,980,064	11,916,577	23,793,028
June.....	3,791,642	2,912,674	6,078,189	7,263,150	13,069,934	24,441,191
July.....	3,828,726	3,044,728	5,061,690	7,353,382	14,116,758	24,888,337
August.....	3,304,405	2,852,544	4,727,877	7,114,195	15,063,651	25,005,187
September.....	2,930,456	2,503,657	4,599,362	7,620,525	6,157,316	25,066,657
October.....	3,040,198	2,504,012	4,221,769	7,794,634	16,877,019	25,309,361
November.....	2,945,092	2,471,798	4,289,909	8,051,469	18,025,409	25,509,285
December.....	2,551,199	3,127,837	4,615,289	8,470,490	18,928,430	26,019,704
Average.....	3,411,822	2,875,434	4,501,306	7,065,834	13,541,682	23,860,051

TABLE IX.—Continued.

Month.	1862.	1863.	1864.	1865.	1866.	1867.	1868.
January.....	26,716,188	35,187,116	35,884,609	37,214,274	34,166,238	33,635,389	26,927,634
February.....	27,099,611	35,692,480	36,041,898	36,737,137	34,082,775	33,288,630	26,084,574
March.....	27,822,825	35,812,255	36,202,262	36,596,236	33,956,493	32,932,602	25,404,276
April.....	28,547,481	37,789,406	38,148,670	36,461,800	33,823,385	32,955,084	24,893,223
May.....	29,206,697	37,755,824	38,631,203	36,139,072	33,969,466	32,642,850	24,653,013
June.....	29,859,452	35,958,935	38,669,838	35,872,257	34,187,377	32,389,750	24,219,496
July.....	31,718,144	36,371,922	38,985,767	35,696,909	34,428,490	32,289,369	23,586,951
August.....	31,774,994	36,164,881	39,084,561	35,343,771	34,800,397	32,003,536	23,142,437
September.....	32,400,303	35,752,677	38,740,734	34,939,962	35,061,614	31,340,939	22,193,819
October.....	32,608,531	35,612,915	38,192,317	31,763,857	33,027,877	30,692,583	22,039,162
November.....	33,728,555	35,506,653	37,925,756	34,668,437	34,825,871	29,825,951	
December.....	34,596,612	35,745,632	37,366,126	31,428,841	34,156,605	28,006,211	
Average.....	30,419,499	35,938,891	37,822,470	35,732,291	34,350,467	31,807,681	

PETROLEUM PIPE-LINES. A descriptive and historical account of the petroleum pipe-lines must necessarily be a history of petroleum transportation, that the reader may obtain a clear understanding of the subject. Very early in the history of the petroleum industry the transportation problem became the most important question, next to the marketing of the oil, to the producer. As all the refineries were located in the city of Pittsburg, Pa., the crude oil as produced at the wells had to be transported to that city, and the cost was fully one-half of the amount realized for the oil. The oil at the wells was placed in barrels made of heavy oak staves and bound with iron hoops. These barrels were coated on the inside with glue, but as crude petroleum invariably contained a small percentage of water this coating of glue did not prove a complete protection, and at times the loss through leakage was serious. These barrels were purchased at a cost of \$3.50 each. A barrel in every respect superior is now made at a cost of \$1.25 to the refiners. The only means of transporting the oil was on wagons drawn by horses, and as the roads were new and for the most part in execrable condition, the hauling of the oil from the wells to the points of shipment on Oil Creek was at times attended with great difficulties. During the first few years of the petroleum industry the teamster exacted his own terms. As the only channels through which oil could reach the market were Oil Creek and the Allegheny River, when the wells came to be located farther from these water-ways the cost of hauling the oil to them increased. Pithole was the shipping point for the oil produced on the Miller farm, only four miles distant, and for carting the oil this distance the teamsters charged \$3 per barrel, and at times even more. Carting oil was the most profitable occupation in the oil regions during the early history of petroleum, and the foundation of many a fortune was laid through the extortionate charges made by the teamsters.

The oil when it arrived at the creek was placed on flat-bottom boats or on rafts and floated down with the current, but as for a great part of the time there was not sufficient depth of water to float the boats or rafts with their cargoes of oil, recourse was had to damming the stream and so accumulating sufficient water to carry the boats and floats beyond the shallows and obstructions. At times there were large accumulations of boats at the points of shipment awaiting a sufficient accumulation of water, and when the dams would at length be opened the rushing of the waters would render control of the boats impossible as they were swept down with the current in inextricable confusion, and frequent collisions and wreckages were the result. During one of these pond-freshets on Oil Creek from 20,000 to 30,000 barrels of oil would be sent through to Oil City. The empty boats were towed up the creek again by horses, who made their way along as best they could, at times along the bank, but for the greater part of the way wading in the stream. At Oil City the barrels of oil were transferred to larger boats. At one time there were upward of 1000 boats and 30 steamers engaged in this traffic. The losses occasioned by collisions and jams were serious and they were of

frequent occurrence. During a freshet in May, 1864, a jam occurred at Oil City, wrecking many boats and occasioning a loss of upwards of 25,000 barrels of oil. Bulk-barges were early introduced on the Allegheny and Ohio Rivers, and these, in an improved form of construction, are still used to convey oil to refineries located along the river. These bulk-boats were at first crude affairs, ill calculated to withstand turbulent river travel, but are now built with eight compartments with water-tight bulkheads, and of a capacity to carry 2000 barrels of oil.

The railroads entering the oil regions early saw the necessity of providing improved means for the transportation of the rapidly increasing amounts of oil seeking transportation facilities, and during the latter half of the year 1865 the tank car was introduced. At first the tank car was simply the ordinary flat car, upon which were securely fastened two wooden tanks with a combined capacity of about 4000 gallons. It was not until the year 1870 or 1871 that the wooden tank car was displaced by the car with a tank constructed of boiler-iron. These cars are still in use for transporting crude oil and the various products of the still. The tanks vary in size, holding from 4000 to 5000 gallons. They are, of course, safer than the wooden ones formerly in use, and are in every way better adapted to the purpose. A number of the larger refiners of petroleum own tank cars, and in this they are encouraged by the railroads.

These difficulties in transportation and great expense of cartage of the oil from the wells to the points of shipment early attracted the attention of engineers and others who sought means to overcome the difficulties and reduce the enormous cost of marketing the product. The earliest attempt to solve the problem by the use of iron pipes to convey the crude oil from the wells was made by Mr. J. L. Hutchinson, of New York, although Gen. S. D. Karns, of Parkersburg, W. Va., suggested the practicability of this mode of transportation early in the autumn of 1860. In 1862 Mr. Hutchinson constructed a line of pipe on the Tarr farm, where the first flowing well had been struck the year before, to the first refinery erected in the oil regions, at Plumer. The wells were on one side of a high hill and the refinery on the other. Mr. Hutchinson believed that a line of pipe laid from the wells over the hill to the refinery would, on the well-known syphon principle, draw the oil over the hill to the refinery. This plan proved a failure. The next year Mr. Hutchinson laid a pipe-line from the famous Sherman well to the terminus of the railroad at the Miller farm, a distance of three miles. To overcome the hydraulic pressure of a column of oil of that length he placed air chambers, similar to those used on hydraulic rams, 10 inches in diameter, along his pipe-line at intervals of 50 or more feet to equalize the pressure. The pressure did not burst the pipes, but although 1000 barrels of oil were emptied into them at the well barely 50 barrels reached their destination. The pipes were of cast-iron with lead sockets, and the joints were brought together with the blow of a mallet. Pumps were used to force the oil through the pipes. The slightest disturbance

of the pipe at the joints would cause a leak, and to this cause was due the failure of the scheme. Mr. Hutchinson was a firm believer in the eventual success of this manner of transporting oil, but although he continued his experiments two years longer he was unable to overcome the mechanical difficulties.

The first successful pipe-line was laid by Samuel Van Syckle, of Morris co., N. J. Early in the history of petroleum developments he went to Titusville. He struck an important well at Pithole, and as he was compelled to pay the teamsters \$1500 dollars per day to haul his oil to Miller's farm, a distance of five miles, he determined to improve on Hutchinson's experiments with pipes as a means of transporting his oil. In 1865, having conceived the idea of joining the pipes with a screw and thimble, he carried it out on a line of four miles in length from Pithole to Miller's farm. The pipe was laid two feet under ground, and as an ascent of 600 feet had to be overcome the feat was declared impossible of accomplishment. When all was completed the pumps were started, and soon a steady stream of oil was pouring into the tanks at the other end of the line, proving the pipe-line theory a success and marking the beginning of a new era in petroleum transportation. The teamsters realized that pipe-lines would prove the ruin of their business and, determining to resist the encroachments of the new invention, tore up the pipe-line as fast as Van Syckle could relay it, but he placed armed watchmen along his line, and after many sanguinary conflicts between the teamsters and the pipe-line men the former finally abandoned their hostile endeavors to check the march of progress. In the fall of the same year Henry Harley, a civil engineer, a graduate of the Troy Polytechnic School, began the construction of a pipe-line from Benninghoff run to Shaffer farm, which he completed in the spring following, and secured control of the Van Syckle line. Later, the firm of Abbot & Harley purchased enough of the Western Transportation Company's stock to control the charter, and organized under it the Allegheny Transportation Company.

The first effort to construct a pipe-line to the seaboard was made by Henry Harley. In 1875 he procured a charter for a company known as the Pennsylvania Transportation Company, which was authorized to construct a pipe-line from the oil regions of Pennsylvania to tidewater. The plan was generally regarded as the extravagant idea of a disordered brain, but was pronounced feasible by eminent engineers, and ample support being given, the transportation company built lines in the producing regions, but later the company was absorbed by a rival. As early as 1877 the oil regions were traversed by ten pipe-lines belonging to as many different companies, and competition to secure the carrying trade reduced the rates to such an extent that the business was no longer profitable. The certificates issued by these companies to the producers, which were equivalent to warehouse receipts, had only a local value, while the solvency of some of them was openly questioned. At this time the pipe-lines were dealers as well as custodians and carriers of oil, and as losses were inevitable under the system then in vogue, some of the companies were crowded out, entailing heavy losses on the producers. The situation became more and more complicated and uncertain, and it appeared that the solving of the transportation problem had but brought new difficulties. This was the situation when the United Pipe-Lines Company was organized, and relief followed quickly. The certificates of the new concern became known as representing the oil actually held in stock, and became negotiable in all the principal trade centres, where their value and safety have never been questioned. At this time all the crude oil transported from the oil regions to New York, Philadelphia, Cleveland, Pittsburg, and Baltimore was by railroad in tank cars. Following the consolidation and the organization of the United Pipe-Lines Company sprang up others in various sections of the oil

regions, but most of these were later purchased by the larger company or abandoned. At the end of 1888 the principal pipe-line companies are the National Transit Company, the successor of the United Pipe-Lines Company, and the Tidewater Pipe Company. There are several others having a local importance only, but their certificates are not sold in open market.

The construction of the long distance pipe-lines was commenced in 1880 by the United Pipe-Lines Company. The principal lines constructed were the Seaboard line, which extends from Olean, N. Y., to Saddle River, N. J., a distance of 300 miles; the Pennsylvania line, extending from Colegrove, Pa., to Philadelphia, the distance being 280 miles. The Baltimore line extends from Milway Station, on the Pennsylvania line, to Baltimore, the distance being 70 miles. The Cleveland line begins at Hilliards, Pa., and extends to Cleveland, O., a distance of 100 miles. The Pittsburg line extends from Carbon Centre, Pa., to Pittsburg, and is 60 miles long. The Buffalo line runs from Four Mile, Cattaraugus co., to Buffalo, and is 70 miles long. There are also several shorter supply lines in the oil regions which convey the oil to the several stations as required. The Seaboard line is a double conduit of 6-inch pipe and extends to the refineries at Bayonne, N. J., while a branch line crossing the Hudson River to New York city passes through Central Park at 64th street, across the city to the East River, and across that stream to the refineries at Hunter's Point and Newtown Creek on Long Island. There are in the oil regions of Pennsylvania and New York between 3000 and 4000 miles of iron pipe, which form a complete network of feeders to the mains or trunk-lines, taking the oil from the tanks at the wells and delivering it at the several stations. At the termini of the trunk-lines, and at the numerous stations, there are immense storage tanks with a capacity varying from 10,000 barrels to 38,000 barrels. Some of these huge tanks are of wood, but by far the greater number are made of boiler-iron. The standard adopted a few years since has a capacity of 30,000 barrels, is made of best boiler-iron, weighing about 80 tons, is 30 feet high and has a diameter of 86 feet.

The principal pipe-lines have no marked or important features differing the one from the other, although the topography of the country traversed varies greatly. A description of one only is therefore sufficient. The most important line has its oil region terminus at Olean, Cattaraugus co., N. Y., which has an elevation of about 1500 feet above the sea-level. The line consists of two 6-inch wrought-iron pipes, tested to bear a pressure of 2000 pounds to the square inch. These pipes are screwed together at the joints with couplings as are the ordinary gas pipes. In order that the pipes and the oil shall not be affected by every change in temperature and to partially overcome the extremes of heat in summer and of cold in winter, the pipes are buried under the surface of the ground to an average depth of about two feet. The pipes are laid in as nearly a straight line as possible, and follow the contour of the country, up hill and down, through forests, across swamps, through the streets of towns and villages, under rivers, across cultivated fields in a straight line to tide-water. At one point in Allegheny county the line overcomes an elevation of nearly 1300 feet within a distance of 4 miles. The route is along the southern boundary of the State of New York, through the counties of Cattaraugus, Allegheny, Steuben, Chemung, Tioga, Broome, Delaware, Sullivan, and Orange, and across the north-eastern portion of the State of New Jersey through Sussex, Morris, Passaic, Bergen, and Hudson counties. At central points in the valleys along the line the pumping stations are located. These stations consist of permanent buildings, a boiler-house and a pump-house, which contains the necessary machinery for pumping the oil, also a telegraph office. At each station are also located two or more of the immense iron storage tanks already described. In the

pump-house are compound condensing engines and pumps, two in number. Each pump has 28 suction-valves and the same number of supply valves. The stroke of the pump is double. At every stroke of the piston a barrel of oil is sent on its way, and a barrel of oil is forced forward every seven seconds, the pumps working day and night. A pressure-gauge indicates the pressure to which the pipes are subjected, and makes known at once any interruption in the flow through break or other cause. Another gauge records every stroke of the pump and shows the number of barrels of oil that have passed through the station. These pumping engines range from 250 to 1000 horsepower, according to the resistance the pumps are required to overcome. The stream of oil flows uninterruptedly day and night, stoppages occurring only when an accident necessitates a cessation of pumping to make repairs.

To each station there are allotted two engineers, two firemen, and two telegraph operators, one-half of the force working by day, the other by night. To detect possible leakages too small to be indicated by the pressure-gauge at the stations, each section of the line between stations is in charge of a lineman, who walks along the section once a week. Should a leak be discovered he at once sends word to the station. To remove sediment and deposits of paraffin, an automatic scraper is introduced into the pipes, the peculiar construction of which insures a thorough scraping of the inside of the pipe, the pressure of the oil forcing the scraper along from one station to the next.

When oil is received from the tanks at the wells the amount is ascertained by a joint measurement made by the representative of the owner of the wells and of the pipe-line, and is placed to the credit of the former on the books of the pipe-line company. Such oil is held in custody of the pipe-line company subject to the order of the owner, the same as are goods sent to a store-house, and the credit balance is negotiable the same as is a warehouse receipt. The producer's credit balances are held free of storage for thirty days, after which time the storage charge is 25 cents per day for each 1000 barrels. All oil when received from the wells becomes part of the common stock of the line, and no holder of a credit balance can therefore claim the identical oil produced at his wells. The certificates issued by the pipe-lines are usually for 1000 barrels, and those issued by the National Transit Company are the certificates sold at the several petroleum exchanges. The daily quotation of the price of petroleum is the price per barrel of 42 gallons, as represented by these certificates.

(H. G. A.)

PETTENKOFER, MAX VON, a German hygienist, was born near Neuburg, Dec. 3, 1818. He was educated at Munich, worked in chemical laboratories at Würzburg and Giessen, and became chemical assistant in the royal mint at Munich. In 1847 he was made professor of chemistry there, and besides other technical improvements introduced a method for the preservation of oil-paintings. He afterwards devoted his attention to hygiene, and in 1865 he was made professor of this department in the Bavarian University. He investigated the influence of soils on public health and the causes of epidemics. He was one of the editors of the *Zeitschrift für Biologie*, in which most of his essays were published, from 1864 until 1883, when he transferred his labors to the *Archiv für Hygiene*. He has published *Populäre Vorträge* (3d ed., 1871), and a *Handbuch der Hygiene* (3d ed., 1882).

PETTIE, JOHN, a Scotch painter, was born at Edinburgh, in 1839. He was trained at the academy of that city, and in 1862 removed to London, where he had already exhibited some pictures. His works often present scenes of old English life. Among them are George Fox Refusing to take the Oath at Holker Hall, A. D. 1663 (1864); An Arrest for Witchcraft (1866); The Disgrace of Cardinal Wolsey (1869);

Juliet and Friar Lawrence (1874); Jacobites, 1745 (1875). Pettie was elected to the Royal Academy in 1873.

PETTIGREW, JAMES BELL, a Scotch anatomist and physiologist, was born at Roxhill, Lanarkshire, May 26, 1834. He was educated at the University of Glasgow, and graduated in medicine at the University of Edinburgh with the highest honors. He won the gold medal by his thesis, "On the arrangement of the muscular fibres in ventricles of the vertebrate heart." He was made Croonian lecturer by the Royal Society of London in 1860, and two years later became assistant curator of the Hunterian Museum, in the College of Surgeons. In 1867 on account of his health he resigned, and spent two years in Ireland. In 1869 he returned to Edinburgh as curator of the Anatomical Museum, and professor of pathology in the Edinburgh Hospital. In 1875 he was made professor of anatomy in the University of St. Andrews, and in 1877 he was elected by the Universities of Glasgow and St. Andrews as their representative in the General Council of Medical Education of the United Kingdom. His earliest investigations were directed to the muscles and nerves of the heart, and by his skill in dissection he solved many difficult problems in anatomy. In 1867 he first presented his novel theory of flight ("Figure of 8") which is fully shown in the article on "Flight" in the *ENCYCLOPÆDIA BRITANNICA*. For his celebrated work *Animal Locomotion, or Walking, Swimming, and Flying* (1873), he obtained a prize from the French Academy of Sciences. He has also published lectures on *The Relation of Plants and Animals to Inorganic Matter* (1873); *The Physiology of the Circulation in Plants, in the Lower Animals, and in Man* (1874), and *Man in his Anatomical, Physical, and Physiological Aspects* (1876).

PFEFFER, WILHELM, German botanist, was born at Grebenstein, near Cassel, March 9, 1845. He was educated at Göttingen, Marburg, Würzburg, and Berlin. In 1871 he began to lecture on botany at Marburg, and two years later was called to professorship at Bonn. He has since been professor at Basél (1877), Tübingen (1878), and Leipsic (1887), being also a director of the botanical garden of the last two. He has made contributions to morphology, but in the department of vegetable physiology he has rendered the greatest service to science. Besides many important essays he has published *Handbuch der Pflanzenphysiologie* (2 vols., 1881-82). Since 1881 he has published *Untersuchungen aus dem Botanischen Institut zu Tübingen*, in which valuable researches by himself and his scholars have appeared.

PFLIEDERER, OTTO, a German theologian, was born at Stetten, Sept. 1, 1839. He was educated at Tübingen University, and after a year's service as a village pastor returned to the University as repent. In 1868 he became city pastor at Heilbronn, and in 1870 superintendent at Jena, where he was soon made professor of practical theology. In 1875 he was called to Berlin as professor of systematic theology. He belongs to the most advanced critical school. He has published *Die Religion, ihr Wesen und ihre Geschichte* (2 vols., 1869); *Moral und Religion* (1871); *Religionsphilosophie auf geschichtlicher Grundlage* (1878), of which an English translation appeared in London in 1886; *Grundriss der christlichen Glaubens- und Sittenlehre* (1880). In the department of New Testament criticism he has published a notable essay on *Paulinismus* (1873), and has contributed much to Hilgenfeld's *Zeitschrift*. In 1885 he delivered the Hibbert lectures in London on *The Influence of the Apostle Paul in the Development of Christianity*.

His brother, **EDMUND PFLEIDERER**, born Oct. 12, 1842, was also educated at Tübingen, and after service as preacher and teacher in various places, returned there as professor of philosophy in 1878. He has published some books on Leibnitz, a volume of rein-

iscences, and essays on modern pessimism and the golden age.

PHELPS, AUSTIN, theologian, was born at West Brookfield, Mass., Jan. 7, 1820. He graduated at the University of Pennsylvania in 1837, studied theology at Andover and New Haven, and was ordained pastor of the Pine Street Congregational Church, Boston, in 1842. He was made professor of sacred rhetoric in the Andover Theological Seminary in 1849, and retired from this position in 1884. He has given much attention to church music and published time-books for churches and Sunday-schools. His other publications are *The Still Hour* (1859); *Hymns and Choirs* (1860); *The New Birth* (1867); *Theory of Preaching* (1880); *Men and Books* (1881); *English Style in Public Discourse* (1883); and collections of his contributions to periodicals under the titles *My Portfolio* (1883), and *My Study* (1885). Dr. Phelps's writings are marked by purity of style, breadth of view, and genial conservatism.

His wife, ELIZABETH STUART PHELPS (1815-1852), the daughter of Prof. Moses Stuart (*q. v.*), was married in 1842, and died Nov. 30, 1852. She wrote *The Sunny Side* and other books for Sunday-schools, generally under the name "Trusta."

Their daughter, ELIZABETH STUART PHELPS, born at Andover, Aug. 31, 1844, wrote several books for the young. Her most noted work is *The Gates Ajar* (1868), which by somewhat novel views of the future state attained great popularity. A latter work, *Beyond the Gates* (1884), was in the same line of thought. In *Doctor Zay* (1883) the question of professional life for women is considered. Others of her books are *Hedged In*; *The Silent Partner*; and *The Story of Avis*. She was married to Rev. Herbert D. Ward in October, 1888.

PHELPS, JOHN WOLCOTT (1813-1886), general, was born at Guilford, Vt., Nov. 13, 1813. He graduated at West Point in 1836, and became second lieutenant of artillery. He served against the Indians in Florida and on the frontier until 1846, when he took part in the Mexican war. He resigned from the service in 1859, but in May, 1861, was made colonel of the First Vermont Volunteers, and then brigadier-general. After brief service in Virginia he went with Gen. Butler's expedition against New Orleans, and assisted in the capture of the forts defending that city. For undertaking to arm negro slaves as soldiers he was declared an outlaw by the Confederate government. When the Union authorities also countermanded his act he resigned his commission in August, 1862, and returned to Brattleboro, Vt. He took much interest in the educational and historical interests of the State, but was especially noted for his active opposition to secret societies. In 1876 he was nominated for President by a convention of the "American" party on this ground, but he received very few votes. He died at Royalton, Vt., Nov. 20, 1886. Among his publications were *Good Behavior* (1880); *History of Madagascar* (1884); and *Secret Societies, Ancient and Modern*.

PHELPS, OLIVER (1749-1809), deserves record as the author of the system of survey by townships and ranges, which has been adopted for the U. S. government lands. He was born at Windsor, Conn., and trained to business pursuits. During the Revolutionary war he was in the commissary department of Massachusetts. In 1788, in company with Nathaniel Gorham, he purchased from that State a tract of 2,600,000 acres in Western New York, being portion of a still larger tract which had been ceded by New York to Massachusetts in 1786. Phelps opening at Canandaigua, N. Y., the first land-office in America, commenced his system of survey, which proved admirably adapted to the condition of the Western country. (See PUBLIC LANDS.) In 1795 he was associated with William Hart and others in purchasing from Connecticut the "Western Reserve" in Ohio,

comprising about 3,300,000 acres. He resided at Canandaigua, became a member of Congress 1803-5, and a judge of the Circuit Court. He died at Canandaigua, Feb. 21, 1809.

PHELPS, WILLIAM WALTER, politician, was born in New York city, Aug. 24, 1839. His father, John J. Phelps, made a large fortune in business and railroad management. William graduated at Yale College in 1860 and at the Columbia Law School in 1863. He quickly obtained extensive practice, but after his father's death in 1869 he was obliged to devote much time to the management of his estate. In 1872 he was elected to Congress from a New Jersey district, and was sent on a committee to investigate affairs in Louisiana. The Legislature of that State was organized in accordance with the committee's decision. After serving several terms in Congress Mr. Phelps was sent in 1881 as U. S. Minister to Austria, but retired the next year and was reelected to Congress. He has taken an active part in the affairs of Yale University, and has delivered several important speeches.

PHILADELPHIA, the chief city of Pennsylvania, See Vol. XVIII. and the second in the United States, has been well described in the *ENCYCLOPEDIA BRITANNICA*; this article will, therefore, treat chiefly of its statistics and of the changes introduced in recent years, with incidental mention of some particulars overlooked.

Buildings.—Great advances in street architecture have been made within recent years. The City-Hall was completed, so far as the elevation is concerned, on May 7, 1887, the tower having reached a height of 337 ft. 4½ in. Above this an iron dome, octagonal and 200 ft. in height, is to be surmounted by a colossal figure of William Penn, 36 ft. high. The clock story is to be decorated by four groups of figures representing Swedes and Indians. When this tower reaches its total height, 537 ft. 4½ in., it will be the highest structure in the world save the Washington monument. (For illustration see Vol. I., Plate III.) Already (1888) several city and county officials and commissions occupy rooms in the hall. The total estimated cost of the building is \$15,000,000, and \$11,853,352 had been expended at last report.

Of recent private structures in Philadelphia the finest is the white marble Drexel Building at Fifth and Chestnut streets. It contains 400 rooms, covering upwards of 190,000 ft. of floor surface. The Stock Exchange occupies the second story of its east wing. The Bullitt Building in Fourth street, the warehouse of Hood & Bonbright on Market street, and the adjoining Girard Estate building are imposing edifices. At no former period of her history have so many fine banks and offices of trust and insurance companies been erected in Philadelphia. Mr. Henry C. Lea has built, at an expense of \$50,000, an annex to the Philadelphia Library, which will be ready for the reception of books in January, 1889. In October, 1888, the cornerstone of a new library building of the University of Pennsylvania was laid. In 1886 the new Homœopathic (Hahnemann) College, Dispensary, and Hospital on Broad street was opened.

The Academy of Fine Arts in 1886 received a permanent endowment fund of \$100,000. Philadelphia has recently acquired two fine bronze equestrian statues, one in Fairmount Park to Gen. G. G. Meade, executed at a cost of \$25,000 by Mr. Calder; the other to Gen. John F. Reynolds, who fell at Gettysburg. Other military monuments are, that to Union soldiers, dedicated in 1883, in Germantown; and that on the Girard College grounds, sacred to the memory of its graduates who fell in the civil war. Philadelphia has sent several patriotic monuments to the fields of Gettysburg and Antietam. Philadelphia, during the civil war, contributed for the maintenance of the Union 88,000 men and expended \$8,500,000.

Among Philadelphia's prized relics of the revolu-

tionary era is the Liberty Bell, cast in London in 1752 for the "Province of Pennsylvania," and bearing the inscription, "Proclaim liberty throughout the land to all the inhabitants thereof. Lev. xxv. 10." It was first used in 1753, and on July 8, 1776, saluted the first public reading of the Declaration of Independence. It was finally cracked on July 6, 1835, while being tolled for the funeral of Chief-Justice Marshall. The bell was lent to New Orleans for its World's Exposition in 1884, and since its return hangs on its old frame in the southern corridor of Independence Hall.

On Sept. 15-17, 1887, the centenary of the framing and adoption of the Constitution was celebrated by civic, military, and industrial parades. The U. S. government, with 17 States and the District of Columbia, contributed to the display.

Government.—The original charter of Philadelphia had undergone various changes before the Consolidation Act of 1852, which brought the whole county (nearly 130 square miles) under one city government. The vastly increased outlay for municipal purposes then rendered necessary gave frequent opportunities for jobbery, while the control of public works was chiefly with committees of the city councils, in which responsibility for maladministration was vague and uncertain. After the burden had grown oppressive the citizens sought relief from the State Legislature, which fixed the limit of the city debt at \$70,000,000, and required the expenditures to be kept strictly within the bounds of annual appropriations, whose total should not exceed the estimated income. Another measure of relief was the granting of powers for specific purposes to boards or commissions composed of prominent citizens. Eventually, however, these independent commissions aggravated the evils they were intended to cure. After various attempts at reform in management under the existing laws, the Legislature authorized the governor to appoint a Committee on Municipal Reform. Mr. John C. Bullitt, a member of this committee, drafted an important bill remodelling the city charter. This bill was, in 1883, introduced into the Legislature by his son, William C. Bullitt, then State Senator, was passed in 1885 and took effect April 1, 1887. Pursuant to this bill the mayor, who formerly was hardly more than chief of the police, has authority to administer nearly the entire city government through various departments, the heads of which are subject to his appointment and removal. These departments are those of Public Safety, Public Works, and Charities and Correction. There are also Departments of Receiver of Taxes, City Controller, and Law, whose chief officers are elected by the people, while the Board of Education is composed of members appointed by the Judges of the city courts.

Public Safety.—This department, with a Director appointed by the Mayor at a salary of \$7500, comprises the bureaus of Police, Fire, and Public Health. The police force consisted in 1888 of 4 captains at \$1350 each; 8 detectives at \$1080; 28 lieutenants at \$1092.50; 70 house sergeants at \$960; 14 patrol sergeants, 14 patrol drivers, 14 patrol officers; 4 pilots; 4 firemen; 5 van-drivers; and 1270 policemen at \$2.38 a day, the total cost of the bureau being \$1,751,710.08. The number of arrests in 1886 was 53,409; number of station-house lodgers, 54,589; number of commitments to prison in 1887, 28,968; to House of Correction, 5841.

The Brooks High License Bill, passed by the State Legislature in May, 1887, fixed the price of license for the sale of liquor at retail in large cities at \$500, and gave the judges large discretion in granting licenses. The License Court in Philadelphia in 1888 granted only 1340 licenses, while the former number of saloons was 5989.

Fire.—In bygone years Philadelphia was famed for its volunteer companies of firemen. In March, 1871, the volunteer system was changed for a paid fire-

department, and this, in 1887, fell under the Department of Public Safety. In 1888 the apparatus of this bureau consisted of 34 steam-engines, 2 chemical engines, and 7 trucks, operated by 34 engine-men at salaries of \$1000 each; 34 firemen at \$867.70; 41 drivers and 7 tiller-men at \$867.70; 41 foremen at \$1100; and 342 hose and ladder-men at \$867.70 each. The number of fires in 1887 was 1222, involving a loss of \$2,857,456, with insurance of \$12,287,301.

Health.—In 1887 there were 24,113 births; 6355 marriages; and 21,719 deaths, of which 8321 were under five years, the percentage of deaths to population being 2.21.

Public Works.—The head of this department is a Director appointed by the Mayor, with a salary of \$7500, and under it are comprised bureaus of gas, water, and highways. In 1886 Philadelphia had 855 miles of gas-pipes; the total number of consumers was 114,386, using 1,886,599 lights. The public lights numbered 15,410. The total gas made was 2,946,407,000 cubic feet. The cost of manufacture was \$3,494,472, the receipts, \$4,659,783, the surplus being applied to the payment of interest on loans, the sinking fund, etc. On April 1, 1887, the gas trustees reduced the price to \$1.50 per 1000 ft.

The principal streets of the city are brilliantly lighted by electricity, which is also liberally used in the larger stores and warerooms. Girard College, since May, 1887, has been illuminated with 35 electric lights upon 7 towers, each 125 ft. high.

Water.—The water pumped into the city reservoirs in 1887 amounted to 32,426,779,765 gallons, giving a daily average of 88,840,492, and, assuming the population to have been then 998,000, a daily per capita allowance of 98 gallons. In 1886 the total receipts of the bureau were \$1,993,328, the cost of operating the works, \$552,454. The total length of pipes laid up to 1887 was 852 miles, and the average length laid annually for the 11 years preceding 1888 was 15 miles. Through the agency of the Philadelphia Fountain Society there are now 61 public drinking-fountains in the city.

Streets.—In 1886 there were in Philadelphia over 2000 miles of highways, of which 900 miles were paved, the greater portion with cobble stones. Formerly this style of pavement was universal, but now a yearly appropriation is made for the replacement of cobble-stones with improved materials, as Belgian blocks and asphalt. The expenditure of the department for 1887 was \$1,010,061, the cost for street-cleaning being \$314,022, yet the condition of the streets in respect to paving and cleaning leaves much to be desired. The total length of sewers was 300 miles.

Almost every leading street, except Broad, is traversed by a car-track, double or single, making not less than 300 miles of street railways, employing some 9000 horses. The uniform rate for a ride is 5 cents and 8 for extreme distances. On Oct. 1, 1884, steam-traction or cable-motor cars began to be run. Now this system has over 20 miles in full operation, with 591 passenger-cars. An electric car built in Philadelphia made an experimental trip on Aug. 4, 1887. It was propelled by means of storage-batteries in the car. The pavements of the streets on which car-tracks are laid are required to be kept in repair between the curbs by the several street-road companies, but this condition is but indifferently carried out and is a source of constant bickering.

In 1888 the total number of dwelling-houses in the city was 274,835, and of stores having dwellings attached 1386. The total number of building permits issued from 1885 to 1887 (both years inclusive) was 21,243, the value of buildings of all descriptions erected in 1887 being \$45,000,000. The new schools erected in the above three years were 39; factories, 212.

Finances.—On Sept. 1, 1887, the city controller estimated the expenses of the departments for 1888 at \$17,110,188.18, exclusive of legal obligations amounting to \$4,438,089.93, the full amount to be provided

according to estimate being \$21,220,253.18. Valuation of taxable property for 1888 was \$647,213,039, a net increase of \$18,533,527 over 1887. Estimated revenue of 1888 from all sources other than current taxes \$8,956,094.78, among these being \$4,000,000 from the gas department and \$1,925,000 from the water department. In order to meet all liabilities a tax-rate of \$2.89 would be required; a rate of \$1.85 yielding only \$10,805,324.86, or \$6,304,863.33 less than the departments ask. Councils, notwithstanding, voted a tax of only \$1.85, and the appropriations were reduced accordingly. On Aug. 1, 1887, the funded debt of the city was \$58,252,720.22; the excess of debt above securities being \$33,967,785.75.

Banking.—In July, 1888, Philadelphia had 42 National banks with a total capital stock of \$22,297,122, and a reserve of \$27,012,700, and deposits amounting to \$76,493,400. Of 18 State banks the capital stock was \$11,450,123; the specie in banks \$6,635,382; deposits, \$2,632,646. A marked feature of Philadelphia banking of recent years has been the establishment of the trust and safe deposit companies, which combine with the general features of banking, offices hitherto confided to individuals, such as the administration of estates, acting as guardians, the direction of various trusts for the benefit of individuals or corporations, etc.

Post-office.—The Philadelphia post-office is the finest U. S. government building out of Washington, affording accommodations not only for its own proper department but also for the internal revenue and pension offices, for civil service examinations, for the U. S. Courts, the railway mail service, the light-house board, signal service station, etc. The receipts of the post-office for year ending June 30, 1888, were \$1,871,786.49; the expenditure, \$782,279.89. The total number of employes was 880. The letter-carriers numbered 513, an increase of 95 since 1885, and the aggregate number of pieces handled in the year was 326,388,247, or an average of 636,234 by each carrier. The money order receipts were \$4,436,928.16.

Schools.—The public schools, in 1887, numbered 460, comprising a Normal School, a High-School, a School of Practice, a Manual Training School, a School of Industrial Art, 21 Night Schools, and 68 Grammar Schools; the remainder being Secondary and Primary Schools. The number of teachers was 2425 and of scholars 110,279. The expenditure of this department for the year was \$2,028,279, and the money invested in grounds, buildings, and furniture amounted to \$7,660,629. A new Catholic High-School of white marble is in course of construction at Broad and Callowhill streets.

Harbor and Marine.—The entries into the port of Philadelphia in 1887 were 1377 vessels from foreign ports with a tonnage of 1,302,196, and 4414 coasting vessels, tonnage not given. Of the latter 1539 were steamers. The clearances were 1055 foreign vessels, tonnage 975,097; and 4805 coastwise. Of the vessels entering from foreign ports 333 were American, of which 17 were steamers, and 1047 foreign, of which 538 were steamers. Of the clearances for foreign ports 224 were American vessels, 15 being steamers, and 843 foreign, 307 being steamers. Of the 4805 clearances coastwise 1819 were steamers. The amount of receipts at the Custom House was in 1885, \$13,918,553.66; in 1886, \$16,303,918.77; in 1887, \$17,950,235.10. The statement of vessels belonging in the district of Philadelphia on June 30, 1888, is shown in the following table:

Sailing vessels (wood),	405.....	gross tonnage,	100,282.69
“ “ (iron),	5.....	“ “	2,891.28
Under 20 tons,	71.....	“ “	950.15
			104,124.12
Steam-vessels (wood),	99.....	gross tonnage,	19,723.39
“ “ (iron),	93.....	“ “	47,695.81
Under 20 tons,	74.....	“ “	1,651.56
			68,070.76

The total exports from the port of Philadelphia in 1887 were to the value of \$33,813,024, of which \$16,865,042 were to Great Britain. The imports were of the value of \$39,570,687, of which \$16,744,437 were from Britain. The Clyde line of steamers, inaugurated by Thomas Clyde in 1842, with one steamer running to New York, operates about 60 steamships and occupies 1000 ft. of wharves along the Delaware. The ship-building works of William Cramp & Sons are especially noted. In 1854 the total tonnage of vessels launched and on the stocks in the 9 ship-building yards then in the city was 13,797. On Sept. 1, 1888, the tonnage of steamers under construction in Cramp's yards was 24,214, the horse-power 44,200. Five of the vessels were for the U. S. government, namely, the Baltimore (cruiser, launched October, 1888), of 4400 tons displacement, and a guaranteed horse-power of 9000; the Yorktown (gun-boat), 1700 tons, horse-power, 3000; the Vesuvius (dynamite-gun cruiser) 700 tons, horse-power, 3500, guaranteed speed, 20 knots; the Philadelphia (cruiser), 4400 tons, horse-power, 9500, guaranteed speed, 19 knots; the Newark (cruiser), 4083 tons, horse-power, 8500. Three other great vessels were on the stocks for private firms. In 1882 fourteen establishments gave employment to in all 2848 hands. Cramp's yards alone now employ 2200.

The channel of the Delaware at Philadelphia is seriously obstructed by two islands, Smith's and Windmill. For preliminary survey in regard to the removal of these islands the U. S. government in 1888 appropriated \$100,000, on condition that the city or State should purchase the title to the islands.

The number of immigrants arriving at Philadelphia in the year ending June 30, 1888, was 37,018, of whom 11,543 were English, 7987 Irish, and 5062 Germans.

Railroads.—In 1886 the receipts of the Philadelphia and Reading Railroad were \$29,343,998 and its expenditure \$16,450,338. The freight carried was 27,748,325 tons, the number of passengers 25,600,760. Its mileage is 327; the number of its engines operated 943, and of its cars 57,354. In 1887 these numbers were largely reduced owing to the great strike in the coal region. The figures for the Pennsylvania Railroad for 1887 were, receipts, \$115,515,506; expenditure, \$77,238,082; freight, 106,128,215 tons; passengers, 68,153,705; engines, 1349; cars, 32,101.

In August, 1886, the Baltimore and Ohio Railroad entered Philadelphia, having completed its Schuylkill East Side road to a new depot at Twenty-fourth and Chestnut streets. From the Schuylkill it passes through a tunnel 5700 ft. long to Poplar street, where it connects with the Reading Railroad. On being released from its receivers early in 1888, the Reading Railroad applied to Councils for leave to extend its line into the business heart of the city by an elevated terminal from Ninth and Green streets to Twelfth and Market. The project has met with considerable opposition and is not yet finally decided. A north-eastern elevated railroad is also projected, its route being from Tacony to League Island, with a branch to Jenkintown. Other efforts have been made to introduce elevated railroads.

Industries.—The census returns of industries, made in 1880, were so obviously incomplete as to lead to a revised census being taken in 1882 under the supervision of Mr. Lorin Blodget, an experienced statistician. His census for the iron industry shows 712 establishments (including rolling-mills, foundries, pipe- and bolt-factories, machinery and steel-works, etc.), employing in all 31,917 hands; the wages paid being \$15,160,175, and the gross product \$58,608,781. The leather trade numbered 100 establishments, employing 2752 men and 730 women and youths, with a product of \$10,712,800. The lumber, furniture, and cognate manufactories yielded a gross product of \$28,325,531. In 1887 there were 130 brewing establishments, producing 1,569,661 barrels yearly, of the total value of \$11,772,458. Mr. Blodget's return shows that the total

number of manufacturing establishments within the city in 1882 was 12,063, employing 242,483 hands, and paying wages amounting to \$83,965,518. The gross value of the product in that year was \$481,226,309.

In 1888 Claus Spreckels, of San Francisco, erected an extensive sugar-refinery on the Delaware River, covering between 9 and 10 acres. The works will have a capacity of 2,000,000 lbs. of sugar daily, employing from 700 to 1000 hands.

Voters.—On Sept. 26, 1888, the county commissioners made return of 232,311 registered voters, an increase of 3219 over the number in 1887; the total vote, Nov. 6, 1888, was 205,444. (J. II.)

PHILIP, KING (*d.* 1676), an Indian chief noted in New England history, was the son of Massasoit, sachem of the Wampanoags, who had formed a league with the Pilgrims, at Plymouth, Mass., in 1621. Massasoit continued friendly to the end of his life in 1661. Then his two eldest sons, Moanum and Pometacon, going to Plymouth, requested English names, and the court called them Alexander and Philip. Alexander dying within a year, Philip became sachem. He resided at Pokanoket, and for a time maintained friendship with the whites as his father had done, but in 1670 there were rumors of his disaffection, so that in the next year an attempt was made to disarm the Indians. Sassamon, a converted Indian, who had given information of the hostile movements of the tribe, was killed, and, when his murderers were tried and executed, the Indians slew several whites. Philip, seeing that the steady advance of the whites was due to their unity of action, prevailed upon the Narragansetts and other tribes to form an alliance to exterminate the English settlers. But the colonies of Massachusetts, Connecticut, and Plymouth made still closer connection to repel the common danger. Capt. Winslow, in December, 1675, marched with 1000 men against the stronghold of the Narragansetts, and destroyed it with all their provisions for the winter. The war raged with greater fury in the following spring. Altogether, 13 towns, with 600 buildings, were destroyed, and 600 colonists slain. But the Indians were overpowered, and Philip, deserted, sought refuge at Mount Hope, R. I. Even here he was pursued by Capt. Benjamin Church, and slain Aug. 12, 1676. His body was quartered, and his head was long exposed on a gibbet at Plymouth. Church published a *History of the war* (1716); republished 1865).

PHILIPPINIANS. See ROMANS, EPISTLE TO THE.

PHILIPPOTEUX, FÉLIX EMMANUEL HENRI, French historical painter, was born at Paris, April 3, 1815. He studied under Cogniet, and in 1833 exhibited his first painting, a scene from the American revolutionary war. His next was *The Retreat from Moscow* (1835), then followed *The Taking of Ypres* (1837), and *The Death of Turenne* (1838). After a visit to Algiers in 1840, he painted many scenes of Algerian life. Among his noted works are *Louis XV. Visiting Field of Fontenoy* (1840); *The Last Banquet of the Girondins* (1850); *Charge at Balaklava* (1859); *Siege of Puebla* (1865); *Meeting of Henri IV. and Sully* (1875). He also produced the remarkable panorama of the *Siege of Paris*. His works have achieved great popularity, due to their exhibition of the pomp and circumstance of war and to their precision in details, but he cannot be said to display in any high degree true artistic feeling.

His son, **PAUL PHILIPPOTEUX**, born in Paris, Jan. 27, 1846, after studying in the *École des Beaux Arts* and with Cogniet and Cabanel, assisted his father in preparing the *Cyclorama of the Siege of Paris*, and afterwards exhibited it in several American cities. He made a similar representation of the *Battle of Gettysburg*, which has been exhibited at New York, Philadelphia, and other cities. He also prepared *Cycloramas of the Falls of Niagara* and of the *Battle of Tel-el-Kebir* for exhibition in London, and of the *Siege of Plevna* for St. Petersburg. Several of his paintings of

war scenes and historical subjects have been exhibited at the Paris Salon. In 1888 he exhibited in Boston a series of thirty large paintings illustrating the career of Gen. Grant. His recent works have been illustrative of American history.

PHILISTINES. The valuable article on this subject in the *ENCYCLOPEDIA BRITANNICA* See Vol. XVIII. correctly says that the Bible represents the Philistines to have been immigrants (Am. Rep.). (Am. ix. 7; Jer. xlvii. 4; Deut. ii. 23;

Gen. x. 14). Its correctness is open to question, however, when it affirms, on the strength of 1 Sam. xxx. 14; Ezek. xxv. 16; Zeph. ii. 5; 2 Sam. viii. 18; xv. 18, etc., that "the Philistines, or a part of them, are also called in the Bible Cherethites," and that David's celebrated "Cherethites and Pelethites" were Philistines. It is at least as natural to understand these passages as representing that the Cherethites were a different people, living to the south of the Philistines.

The statements found in Gen. xxi. 32, 34; xxvi. 1, 8, 14, 15, 18; Exod. xiii. 17; xxiii. 31; Josh. xiii. 2, 3; Jud. iii. 3, etc., to the effect that the Philistines were already in their seats in the Mediterranean lowland in the time of Abraham, and that they lived there from that time on, are indeed "inconclusive" from the point of view of those who reject these statements as unhistorical; but from any other point of view we must regard this evidence as dating the Philistine immigration at a time not later than Abraham. The Book of Joshua says that Joshua conquered all this lowland region, but specifies the Philistine cities as exceptions (x. 40, 41; xi. 16; x. 29-34; xii. 11-15; xv. 11, 38-47, etc.; cf. xi. 22; xiii. 2, 3). Except, therefore, on the basis of the wholesale rejection of the existing evidence, it is a mistake to say that "the first real sign of the presence of the Philistines is when the Danites, who in the time of Deborah were seated on the sea-coast (Jud. v. 17), were compelled—obviously by the pressure of a new enemy—to seek another home far north, at the base of Mount Hermon (Jud. xviii.)." There is nothing in the history to justify the inference that the migration of the Danites to Laish was caused "by the pressure of a new enemy;" the enemy which, at some date or other, pressed the Danites to the hill country, is expressly said to have been not the Philistines but the Amorites (Jud. i. 34, 35); and the migration to Laish occurred before the death of Phinehas, the high-priest (Jud. xx. 1, 28), and consequently a generation or more earlier than the times of Deborah. The first real sign of the presence of the Philistines, according to the testimony of the Bible, which is all the evidence we have in the case, is in the times of Abraham; the first appearance of the Philistines as the oppressors of Israel is in the times of Deborah herself, and not in the earlier times when the Danites took Laish.

The careful reader of the Bible will find the following statements to be true, though they differ alike from those made in the article in the *BRITANNICA* and from most of the opinions currently held. The Biblical records represent that there were four periods of Philistine oppression of Israel before the reign of David. The first was in the time of Shamgar and Deborah (Jud. iii. 31; v. 6, 8). It is again mentioned, by way of reminiscence, in Jud. x. 11. The accounts of it are very meagre, but the statement that Shamgar's weapon was an ox-goad, and Deborah's asking whether there was shield or spear among 40,000 in Israel, suggest the existence of a state of things like that which existed afterward in the time of Saul (1 Sam. xiii. 19-22); and thus suggest that the Philistine oppression of Shamgar's time was very effective and severe. The fact of such an oppression over the southern tribes existing at that time affords a better explanation than those commonly given for the absence of Judah from Deborah's roll-call of the tribes (Jud. v. 14-18).

The second Philistine oppression is mentioned in Jud. x. 7, in connection with the administration of

Jair, and as preceding the Ammonite oppression of eighteen years, from which Jephthah delivered Israel. (See ISRAEL.) This second Philistine oppression is probably that of the times of Samson; the traditional opinion, which identifies the times of Samson with those of Eli, is not well grounded. In regard to this oppression not much is told us apart from the personal exploits of Samson, but we are informed that in Samson's youth the Philistines were recognized as lords of Judah (Jud. xv. 11), coming up into the country on slight provocation, while toward the close of Samson's life, after he had been twenty years judge, the Philistines seem to have found it necessary to entrap him across the border in order to attempt anything against him (Jud. xvi.). It therefore seems that Samson actually accomplished a deliverance for Israel, as it had been promised he should (Jud. xiii. 5).

The third Philistine oppression was that of the times of Eli. The rescue from this under Samuel was complete, and lasted for many years (1 Sam. vii. 10-14). The fourth Philistine oppression began in the reign of Saul, after Saul had been so long on the throne that his son Jonathan had grown to be a warrior (1 Sam. xiii. 3 seq.). At first the Philistine success was complete, but later Saul maintained himself against them with greater or less success until the overwhelming defeat at Gilboa, where he met his death.

The statement that "Philistia was never a part of the land of Israel" is hardly consistent with 2 Sam. viii. 1, 12; 1 Kings iv. 21, and many other statements in the record. The account in the Bible seems to be that the Philistines became tributary to David, and remained under tribute to his descendants till the times of Jehoshaphat and Jehoram (2 Chron. xvii. 11; xxi. 16). After the division they naturally belonged to the southern kingdom, as their territory was a part of that of the tribe of Judah. The fact that we have two accounts of sieges of Gibbethon by the kings of northern Israel does not at all justify the inference that "the house of Ephraim . . . laid claim to the suzerainty over Philistia." The fact that Ahaziah of Israel sent to inquire of a Philistine god (2 Kings i.), or the fact that the Shunamite woman went to sojourn in the land of the Philistines (2 Kings viii. 2) do not necessarily prove that the Philistines were then entirely independent of Judah. But evidently they had then already become politically important. The revolt in the time of Jehoram of Judah soon followed (2 Chron. xxi. 10, 16). Shortly afterward the dynasty of Omri was overthrown by Jehu, who took the throne as the vassal of Shalmaneser II., of Assyria. At the same date the dynasty of David was for six years displaced from the throne of Judah by Athaliah. After this, when we first hear from the Philistines (Am. i. 6-8, et al.) they seem to be independent of Judah.

The contact of the Assyrians with Philistia does not begin with Tiglath-pileser (B. C. 734). Shalmaneser II. says that he took tribute from all the kings of the sea-coast, Tyre being expressly specified, and the Philistines very likely being included. However this may be, his grandson, Rimman-nirari III., whom the Assyriologists date as reigning B. C. 812-783, but whose date would be some forty years earlier by the chronology found in the margins of most Bibles, the contemporary of Jehoahaz and Jehoash of Israel, explicitly claims suzerainty over the Philistines. See Smith's *Chronology*, p. 115, or Schrader's *Cuneiform Inscriptions*, translated by Whitehouse, p. 203-206. In the times of Jeroboam II. and Uzziah, when the Assyrian power was broken in all these regions, Uzziah partially re-established the power of Judah over the Philistines (2 Chron. xxvi. 6, 7). Under his grandson, Ahaz, they again became hostile (2 Chron. xxviii. 18; Isa. ix. 12), and from that time on they mingled prominently in the struggles in which Judah, Egypt, Assyria, and Babylonia were engaged. (w. J. B.)

PHILLIMORE, SIR ROBERT JOSEPH (1810-1885), an English jurist, was born in London, Nov. 5, 1810.

He was educated at Westminster School and Christ Church, Oxford, graduating in 1831. He was afterwards clerk in the Board of Control, was called to the bar at the Middle Temple, and became Queen's Counsel. Besides having extensive practice in civil courts, he was made chancellor of the dioceses of Chichester and Salisbury. He was elected to Parliament from Tavistock in 1853 and took an active part in legislation pertaining to ecclesiastical affairs. In 1862 he was made advocate-general in admiralty and received the honor of knighthood. In 1867 he was made Judge of the High Court of Admiralty and of the Archdeaconry of Canterbury, being then sworn of the Privy Council. After holding other offices he was in 1875, on the reorganization of the courts, nominated judge of the admiralty and probate division of the High Court of Justice, which office he held till his death, Feb. 4, 1885. As a writer his fame rests on his valuable *Commentaries upon International Law* (4 vols., 1854-61). He also published *Memoirs of George Lord Lyttleton* (2 vols., 1845); *Ecclesiastical Law of the Church of England* (3 vols., 1873); an annotated translation of Lessing's *Laocoön* (1874), and several treatises of temporary interest.

His daughter, CATHARINE MARY PHILLIMORE, has written *The King's Namesake* (1872); *Thoughts on Marie Antoinette* (1873); *Pictures from the Early History of Venice* (1874); *Scenes from the Life of Savonarola* (1881), and has edited the *Eikon Basilike* (1879), which she maintains to be the work of King Charles I.

PHILLIPS, WENDELL (1811-1884), orator, was born at Boston, Nov. 29, 1811. His father, John Phillips (1770-1823), was chosen first mayor of Boston in 1822. Wendell graduated at Harvard College in 1831 and was admitted to the bar in 1834. His natural gifts, social advantages, and scholarly training seemed to mark him out for conspicuous success in the usual course. But his destiny was swayed by his profound moral character, moved by the peculiar circumstances of his city, State, and nation. Boston was a centre of wealth and refinement, but still more was it a city of merchants. The commercial spirit guided its action, when, on Oct. 21, 1835, a mob of gentlemen gathered to break up an anti-slavery meeting presided over by a woman. Their wrath had been especially roused against George Thompson, an English anti-slavery lecturer, but when he escaped, they seized and dragged through the streets with a rope the non-resistant William Lloyd Garrison. The sight of this infuriated, well-dressed mob stirred Phillips' moral nature to its lowest depths, and this pure-souled, high-born lawyer joined in spirit with the persecuted abolitionist. Two years of thought and study passed before he was prominently identified with that cause. A meeting was held in Faneuil Hall on Dec. 8, 1837, to make on behalf of Boston a protest against the murder of Rev. Elijah P. Lovejoy at Alton, Ill., who had been killed by a mob while defending the printing-office of his anti-slavery newspaper. Rev. Dr. Channing made an impressive address and proposed resolutions, when Mr. J. T. Austin, State attorney-general, who had come with others to divert the meeting from its purpose, strenuously objected. Phillips was called on to reply and at once overwhelmed the apologist for murder with a torrent of indignant eloquence. But the moneyed aristocracy of Boston closed their doors in the face of the champion of abolitionists. He never faltered. He adopted Garrison's view of slaveholding as a sin, personal and national, and immediate emancipation as a duty. Believing that the U. S. Constitution by its compromises recognized and supported slavery, he gave up his legal practice and even the exercise of the elective franchise as contaminating. But he used all the more the mighty power of the platform and the press. He spoke without pay wherever he had a chance to be heard on his chosen topic. For addresses on other subjects he was paid, but he generally turned the proceeds into a fund to advance the cause

to which he had consecrated his life, his fortune, and his honor. The power of steady, systematic agitation he afterwards acknowledged he had learned from the example of Daniel O'Connell. Phillips' eloquence and devotion profoundly influenced public opinion throughout the North, though the number of professed abolitionists always remained small. Other causes operated to hasten the national crisis. At last war came, not from the North against slavery, but from the South against the Union, which the slaveholders rejected as an insufficient safeguard of their peculiar institution. Then Phillips urged with renewed emphasis on the Northern people and their leaders the expediency and duty of emancipation. Only after twenty months' struggle to avoid resorting to this momentous war-measure did President Lincoln issue his emancipation proclamation, Jan. 1, 1863. But Phillips still condemned the administration as sluggish and dilatory and opposed Lincoln's re-election. In 1865, when the war was brought to a triumphant close, Garrison proposed that the American Anti-Slavery Society, of which he had been president for thirty years, should be disbanded as having accomplished its object. But Phillips insisted in prolonging its work until the negro should have the constitutional right of suffrage. He was its president from that time until 1870, when it dissolved. Part of its later work was to secure the removal of race distinctions in public institutions and conveyances and in all places of public resort. Phillips had from his first entering the ranks of the Abolitionists urged the admission of women to their societies on equal terms, and he pleaded in their behalf at the World's Anti-Slavery Convention in London in 1840. The close of the war gave leisure to many whose energies had been therein occupied, and the cause of women's rights received a great access of numbers and enthusiasm. Phillips was still a prominent advocate of this and other social changes. His sympathies were manifested in behalf of the Indians, who had been cheated and oppressed both under the treaties made with their tribes, and in violation of such treaties. The perennial sufferings of the working classes became also the subjects of his consideration. He became an ardent champion of temperance, and even of State Prohibition. In 1870 he was nominated by a convention of Prohibitionists for the governorship of Massachusetts. A few years later he advocated the governmental issue of an irredeemable paper currency. In this Greenback movement he came to agreement with another Massachusetts man, whose career otherwise presents a striking contrast with his own—Gen. Benjamin F. Butler. But little effect, however, was produced by the movement except Gen. Butler's election to the governorship, when the Greenback party was merged in the Democratic. But another noteworthy event marked the seventieth year of the veteran agitator. In 1881 his Alma Mater, who had so long shown marked coldness towards her noble son because of his denunciation of popular evil, so far relaxed her severity that he was called to make the address on the centennial anniversary of the Phi Beta Kappa Society. His Puritanic conscience compelled him even then to say some things hard to listen to, but the oration was worthy of the man and the place. He delivered his last public address on Dec. 26, 1883, and died at Boston Feb. 2, 1884. (J. P. L.)

PHILLIPS, WILLARD (1784-1873), lawyer, was born at Bridgewater, Mass., Dec. 19, 1784. He graduated at Harvard College in 1810, and was tutor there until 1815. Having been admitted to the bar he practised law in Boston until 1845 with conspicuous success. He was employed by a legislative commission in codifying the criminal law of Massachusetts, and from 1837 to 1847 he was county judge of probate. Thereafter he was president of the New England Mutual Life Insurance Company until his death, Sept. 9, 1873. He was a contributor to the *North American Review*, and for some years editor of the *American*

Jurist. He was associated with Edward Pickering in editing *Reports*, prepared legal treatises on insurance and patents, and published a *Manual of Political Economy* (1828) and *Protection and Free Trade* (1850).

PHILLIPSBURG, a city of New Jersey, in Warren co., on the Delaware River, opposite Easton. It is on the Belvidere-Delaware Railroad, which here connects with the Morris and Essex and the New Jersey Central Railroad. Two railroad bridges cross the river here. Phillipsburg has two banks, seven churches, a high-school and other schools, and a weekly newspaper. There are several iron-foundries, a rolling-mill, boiler- and locomotive-works, and other iron-works. Its population in 1880 was 7181.

PHILPOTTS, HENRY (1778-1869), English bishop, was born at Gloucester in 1778. He was educated at his native town and at Corpus Christi College, Oxford, where he graduated in 1795 and was then elected a fellow of Magdalen College. He was made one of the chaplains of Rev. Dr. Barrington, bishop of Durham, in 1806, afterwards prebendary of Durham Cathedral. In 1828 he was made dean of Chester. He had opposed Canning's plan of Roman Catholic emancipation and was consulted by the Duke of Wellington in regard to the act for that purpose passed in 1829. He was made bishop of Exeter in 1830 and was thenceforth the official leader of the High Church party in all the controversies of a stormy period. In 1849 he refused to institute the Rev. Mr. Gorham in a church living on the ground of his denial of baptismal regeneration. The judicial committee of the Privy Council, however, decided in Mr. Gorham's favor, but when the Archbishop of Canterbury carried out the decision, Bishop Philpotts anathematized the archbishop. He wrote an abundance of controversial pamphlets but no work of importance. He died at Bishopstoke, Sept. 18, 1869.

PHIPS, or PHIPPS, SIR WILLIAM (1651-1695), colonial governor of Massachusetts, was born at Woolwich, Maine, Feb. 2, 1651. His parents had twenty-six children, of whom twenty-one were sons. In boyhood he was a shepherd, but at the age of eighteen bound himself to a ship-carpenter, and in 1673 he removed to Boston, where he learned to read and write. Going to England in 1684 he obtained from the Admiralty the use of a vessel to recover the treasures from a Spanish wreck, near the Barbadoes, but was unsuccessful in this first attempt. In 1687 a second was made with the aid of the Duke of Albemarle, and treasure was recovered to the amount of £300,000, of which Phips' share was £16,000. His partners also procured for him the honor of knighthood, and he was appointed high-sheriff of New England. In May, 1690, he captured Port Royal in Nova Scotia, but in October his fleet of thirty-four sail was three days too late to capture Quebec, reinforced in the meantime by Frontenac. While in England in 1692 he was appointed governor of Massachusetts through the favor of Increase Mather, the colony's agent in England. He returned to Boston in May, where his administration was made notorious by the delusion of the Salem witchcraft. Phips, a member of Cotton Mather's congregation, for a time willingly followed his pastor in the hideous persecution, but finally issued a general pardon to all accused of witchcraft. There had been a strong opposition to his government, and in 1694 he was summoned to England to answer the complaints brought against him. He died suddenly at London, Feb. 18, 1695.

PHENIXVILLE, a borough of Chester co., Pa., is on the S. bank of the Schuylkill River, 28 miles N. W. of Philadelphia. The Pennsylvania and the Philadelphia and Reading Railroads pass through the town. The former has here a branch-road to Frazer, and the latter has the Pickering Valley branch. The extensive iron- and steel-works of the Phoenix Iron Company and the Phoenix Bridge Company give employment to 2400 men. Several fine bridges erected by these companies span the Schuylkill River and French Creek in

the vicinity. Phoenixville has two national banks, 1 daily and 2 weekly newspapers, 10 churches, manufactures of cotton goods, stockings, pottery, needles, shirts, and boiler-works. The borough was incorporated in 1849. It has gas- and water-works, and is free of debt except the water-loan of \$220,000. Electricity is used to light the iron-works. Near the town is a beautiful cemetery containing a monument to the soldiers who fell in the civil war.

PHOSPHATES are the compounds formed by the union of basic bodies with phosphoric anhydride, P_2O_5 . Of these much the most important, and the one to which our attention will be confined, is phosphate of lime, $3CaOP_2O_5$, which forms the principal constituent of several minerals, especially of APATITE (*q. v.*), and is the basis of all bones and horns. Phosphorus, indeed, occurs in nature principally in the form of phosphate of lime, from which it is usually derived. Thus combined it appears to be an essential element of plant food, concentrating itself particularly in the seeds of plants, whence it enters into the food of animals, to which it is perhaps even more necessary.

Lime phosphate occurs in many forms in the superficial deposits of the earth's surface, and is the basis of most of the artificial fertilizers which are now so largely manufactured, and of the natural manures which are applied without special preparation to the soil. It is, for instance, an important constituent of guano, whose value depends very largely on the percentage of lime phosphate which it contains. It also forms a minor constituent of the marls which occur in such abundance in this country, vast deposits existing in New Jersey, and in a broad belt running parallel to the coast from South-east Virginia to the western limit of Georgia, and thence across Alabama into Mississippi. The percentage of phosphates in these marls is small, yet it is sufficient to add considerably to their value as fertilizers.

Far the most important deposits of phosphates, however, are those which are known as "phosphate rock" which exists abundantly in South Carolina and elsewhere. The marl beds near Charleston, S. C., are overlaid by a stratum of what was formerly supposed to be nodules of limestone, and was thrown aside as useless in the mining of these marls. These "marl stones" were hard, rounded concretions, from the size of a potato to a diameter of several feet, and had evidently gained their rounded form by rolling in water. In 1867 Dr. St. Julian Kavenal was induced to examine them, and quickly discovered that they contained phosphate of lime to the important extent of 55 to 60 per cent. The announcement of this fact was followed by the discovery that, in addition to the known deposits, the rivers near Charleston flowed over beds paved with this rock. So far as has been ascertained the beds of phosphate rock underlie an area 70 miles in length and 30 miles in greatest width, and are practically inexhaustible as sources of fertilizing material. The State receives a royalty on all phosphate rock removed from navigable streams, the quantity paid on in 1886 being 191,174 tons. Nearly the whole of this river rock is shipped to foreign and domestic ports, the South Carolina phosphate-factories using the land rock almost exclusively. In 1884 there were 40 such companies, engaged in crushing the rock into fertilizing material.

Similar deposits exist in North Carolina, in which State a special survey made in 1884 disclosed nearly 150 separate beds of phosphate nodules. These are found in a belt of territory 15 to 20 miles wide, and extending from the Neuse River to the South Carolina boundary. It runs parallel to the coast and from 20 to 25 miles inland. Similar rock has also been discovered in Florida, occurring in the north-western part of the State, and also near Gainesville, in the central region. In places these beds are 6 to 8 feet thick.

The phosphates here described are of animal origin, and belong to the early tertiary age of geology. Phosphatic deposits of cretaceous age have been found in Alabama and Mississippi, and taken as a whole the American phosphate-beds promise to be of immense value to agriculture. In addition to the natural phosphatic fertilizers the manufacture of artificial ones is an industry of considerable importance. For a description of these see FERTILIZERS. (C. M.)

PHYLLOXERA (*Phylloxera vastatrix*, Planchon). In 1865 Prof. J. E. Planchon, of Montpellier, France, announced the discovery of the fact that the disease of the grape-vine, which had attracted much attention in the south of France around the mouth of the Rhône, was due to the work of a minute plant-louse on the roots. It had previously been described under three different generic names in its apterous form, but it was properly placed by Planchon in the genus *Phylloxera* and given the specific name of *vastatrix*. In 1854 Dr. Asa Fitch of New York had described an American grape-leaf gall-louse under the name of *Pemphigus vitifoliae*, and in 1869 M. J. Lichtenstein of Montpellier, France, suggested that this species might be identical with *P. vastatrix*. Acting upon this suggestion, Prof. C. V. Riley, then State Entomologist of Missouri, in 1870 established the identity of the two insects, and in 1871 proved the existence of the root-inhabiting form in this country, announcing, in the *Fourth Missouri Entomological Report*, that there is every reason to believe that the failure of the European vine in this country and the partial failure of the hybrids of our vines with the European, as well as the deterioration of the tenderer native varieties, are chiefly due to the work of this insect. Prof. Riley's conclusions as to the identity of the American and European insects were proven correct the same year by European observers, and were again confirmed by Prof. Planchon in 1873 when he visited this country under a commission from the French government. The most important result of his visit was the dissipation, to a great extent, of the prejudice existing against the American vine in France and the confirmation in his official report of all the more important facts and conclusions previously announced by Prof. Riley, especially as to the resisting power of many of the native American vines. A standing reward of 300,000 francs offered by the French government for an efficient remedy has stimulated an enormous amount of experiment in that direction. Journals were founded devoted to this one subject, and an extensive literature on the subject has grown up since 1869.

The native home of the Grape Phylloxera is the North American continent east of the Rocky Mountains, and extends from the Gulf of Mexico to Canada. From this region it has been introduced into Europe and, recently, into California. It exists in two forms, the one in galls on the leaves—called by Riley *gallicola*—and the other on the roots—*radicicola*. In the gall-making form the species exists only as an agamous, apterous and very prolific female, with a smooth skin. The galls are transient, and may be abundant one year and very scarce the ensuing year on one and the same vine. The root form closely resembles the gall-making individual at birth, but deviates later by acquiring tubercles (see illustration). The insect passes the winter in the so-called "winter-egg" state, either above or below ground, or it hibernates as a young larva, darkened in color and flattened in form, on the roots, where it can scarcely be distinguished. In the following spring the winter-egg gives birth to a wingless, agamic female, which Riley calls the "stem-mother," and which may start a colony either in a gall on the leaves or on the roots, the former being the more common habit. Late in summer there is produced from the root-feeding form a generation of winged agamic females, which fly abroad and spread the species. Each of these winged females lays from 3 to 8 delicate eggs, most often in or on the ground at the base

of the vine or occasionally on the lower surface of the living leaf. They are so delicate as to require especially favorable conditions to enable them to hatch. From these eggs, which are of two sizes, come the only true sexual individuals—males and females—the males from the smaller eggs and the females from the larger. They are born without mouth-parts and take no food. The female, after having been impregnated, lays a single egg, which is the only directly impregnated egg produced in the life-cycle of the species, and which is usually secreted under the loose bark of two-year-old cane, and there hibernates. Such is the usual round of life of the species, the exception being that the wingless hypogean females may occasionally bring forth the sexual individuals without the intervention of the winged generation.

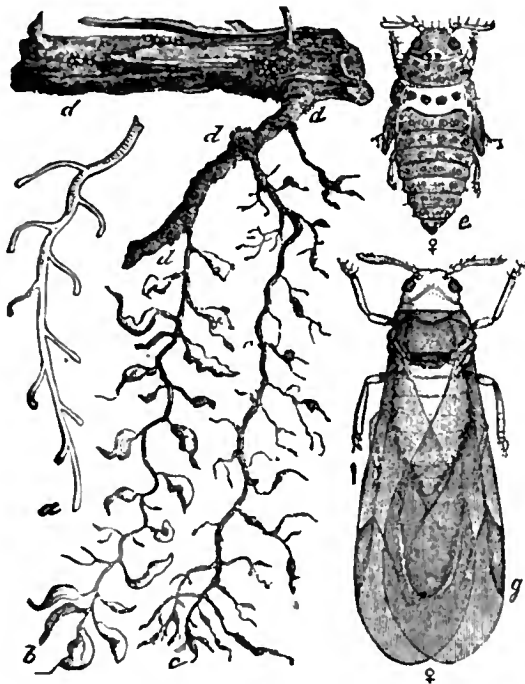

Phylloxera vastatrix: a, healthy rootlet; b, rootlet with swellings caused by *Phylloxera*; c, do. with swellings rotting; d, lice on larger roots; e, pupa; g, winged female—hair-lines showing natural size.

The insect spreads from vine to vine in the wingless state, but the winged individuals—the immediate precursors of the sexual individuals—are capable of quite extended flight, and spread the species from vineyard to vineyard. It may also be carried to remote districts in the winter-egg on cuttings.

The grape-vine most susceptible to the attacks of the root form of the phylloxera is the European *Vitis vinifera*. Of the native American varieties the most susceptible—the Catawba, Delaware, and the Goethe—belong to the Northern fox-grape (*Vitis labrusca*). The hardiest and most resisting species among the bunch grapes belong to *Vitis aestivalis*. The gall form is found most abundantly on the wild winter- or frost-grape (*Vitis cordifolia*), and least abundantly on the European vine (*V. vinifera*). The symptoms of the disease above ground are a sickly yellowish appearance of the leaves and a reduced growth of the cane. This is visible only during the second year of the attack, and about the third year the vine usually dies. The symptoms below ground the first year consist of swellings on the rootlets; the second year of the rotting and disappearance of the fibrous roots and the settling of the lice upon the larger roots, which rot away during the third year.

The natural enemies are quite numerous, though

they are principally found preying upon the gall-inhabiting form. The remedies tried have been almost innumerable. The most effectual so far experimented with is the use of bisulphide of carbon, inserted by means of a special injector, one of the best being that

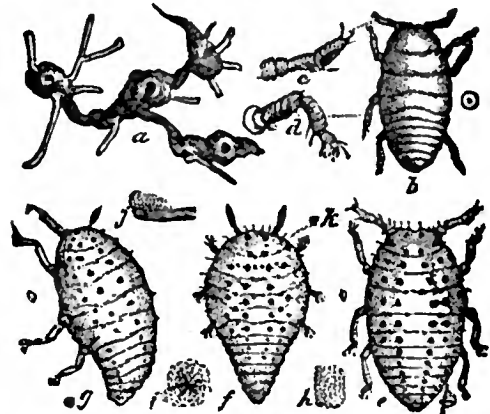

Phylloxera vastatrix: a, swellings on roots; b, newly hatched root-lice; c, d, its antenna and leg; e, f, g, forms of more mature lice—natural size indicated at side.

invented by M. Gastine, and known by his name. Sulfo-carbonate of potassium is the next remedy that has so far been used; about a pint to 40 gals. of water is employed to each vine, poured into a circular trench around the vine. Petroleum emulsion, *i. e.*, two parts of kerosene emulsified in one part of sour milk, and this mixed with from 40 to 100 parts of water, and used in a similar manner, is recommended as still more satisfactory. Submersion, where practicable, the use of rich fertilizers, the adoption of the American resistant varieties—like Taylor, Clinton, Jacques, etc.—as stocks upon which to graft susceptible varieties, are the most satisfactory.

See the *Fourth, Fifth, Sixth, Seventh, Eighth, and Ninth Missouri Entomological Reports*; the *Reports of the California State Horticultural Commission*, and the *Reports of the French Commission Supérieure du Phylloxera*.

(C. V. R.)

PHYSICAL EDUCATION. In very remote periods a definite association was recognized between health, longevity, and physical exercise, and this became a little later an integral part of the creed and the civilization of all the most powerful nations of the world, many of whom owed to its recognition their most brilliant successes in both warlike and artistic pursuits. In Greece, especially, the cultivation of the body by means of gymnastics begun in the earliest life of the individual, fostered and encouraged by the enormous rewards in both fame and riches accruing from success at the Olympic games, and aided by a rigid application of the principles of heredity, eliminating almost completely those persons unfit for the founding or propagating of families, resulted in the nearest approach to physical perfection in an entire people that the world has ever witnessed. Aristotle considered a commonwealth essentially defective if gymnastics were not a part of its code, while Plato called him a cripple who, cultivating his mind alone, suffered his body to "languish through sloth and inactivity." The labors of gymnastics, he very truthfully says, if excessive, may make men hard and brutal, but under proper restrictions they stimulate the spiritual element of their nature, make them courageous, and bring their passions under control.

The Greek gymnasia were not only schools for the cultivation of the body, but exerted the greatest influence upon the development of art and upon intellectual progress. The idea ever present to the minds of the Greeks that the first care of life should be the preservation of bodily health, without which all other advan-

tages of mind, of rank, of fortune, became void and ineffective, resulted in the establishment of an ideal of physical beauty and excellence which reacted upon their art, their manners, their entire civilization, and made them in certain directions pre-eminently superior to the rest of the world. Personal hygiene, and what we now call physical culture, had already attained with them the dignity of a science. The god of physicians was the presiding deity of the gymnasia, and none were considered so well qualified to regulate this branch of education as those best acquainted with the art of medicine. Their five favorite exercises—constituting the pentathlon—running, leaping, wrestling, hurling the lance, and casting the discus, were admirably adapted to supplement one another in developing the body and conferring a high degree of strength and vigor, together with grace, celerity, and accuracy of movement. Whatever was needed in addition was supplied by their games of ball, by their practice in lifting and carrying weights, and by swimming, pugilism, and other athletic sports.

During the middle ages gymnastic and athletic proficiency became the almost exclusive property of the nobility and the professional soldiery, and was displayed only at tournaments and in actual warfare. Among those comparatively small classes it was, however, brought to a great degree of perfection, and it has been said that, even after the middle of the fourteenth century, the levy of a small German burgh could turn out more athletes than the combined armies of the empire.

It was not until the beginning of the present century that gymnastics became systematized or popularized among modern nations. In Germany Jahn established his gymnasium, or Turnplatz, at Berlin, in 1811, introduced new apparatus, improved the defective system of exercises, published a celebrated essay on the principles of gymnastics, and organized the *Turnvereine*, gymnastic societies which, apart from their occasional connection with political movements, have been of the greatest practical benefit not only to their members, but, by force of example, to the community. As a system of exercises is now employed for all the armies of the German empire, and as all able-bodied adult male citizens are required to give three years of personal military service, it is evident that nearly the whole male population of Germany enjoys the advantages of a systematic physical education at a period of life when training is most valuable and important. In Switzerland, Sweden, and France, societies analogous to the *Turnvereine* were formed, and finally government action was taken making gymnastic exercises compulsory in most of the educational institutions as well as in the army. In England, directly after the Crimean war, a commission was appointed to consider the subject, and upon its report a code of instruction in physical exercise was prepared by Mr. MacLaren, of Oxford, which is now in satisfactory operation at all the barracks of the British army.

In this country, although there are many excellent gymnasia in the large cities, it is only within the last decade, and then at but few of the more important colleges, that gymnastics have been regarded as more than a pastime for the younger males, or a prescribed and unpleasant remedy for some of the ailments of the older members of society. In 1881, in the Northern and Middle States, only three educational institutions in a thousand paid any official attention to gymnastics, athletics, or physical education. That this is not the proper position of athletics in an intelligent community has become evident to all thinking people; but there are comparatively few who realize the incalculable power for good which physical education, rightly understood, encouraged, and applied, could have upon the human race in years to come.

The excellent work and writings of MacLaren, Ralfe, Ball, Sargent, Hartwell, Blaikie, Oswald, Schaible and others, have done much to diffuse accu-

rate knowledge of its true value, and should be consulted by all who desire complete information on the subject.

Health consists, in a comprehensive sense, in such a condition of growth and development of all the organs of the body as enables them to fulfil their functions easily and completely, respond promptly to occasional unusual demands upon them, and resist effectually the attacks of disease. These unusual demands upon the energies of the body are continually occurring in everyday life, and should be of themselves sufficient inducement to all persons to aim at the highest attainable condition of health; but when we know that on a certain day or during a certain time such an exceptional demand will be made on the organism to put forth all its powers, we aim especially to prepare it to meet that demand, and such preparation, whether preliminary to the exploration of a continent, the vicissitudes of a campaign, the fatigue of a week's shooting, or the strain of a four-mile boat-race, we call "training." MacLaren has thus well defined training as a "method of putting the body with extreme and exceptional care under the influence of all the agents which promote its health and strength, in order to enable it to meet extreme and exceptional demands upon its energies." Ralfe defines it as "the art which aims at bringing the body into the most perfect condition of health, making muscular action more vigorous and enduring, and increasing the breathing power." Dr. Parkes says, "Training is simply another word for healthy and vigorous living."

Of the agents of health which are employed in the process of training, exercise is the most important, though food, drink, rest, sleep, air, bathing, and clothing are elements which must be carefully considered. To understand how exercise produces strength and health, we should remember that the life of the body as a whole depends upon the life of numberless atoms which constitute it, and which are continually dying, being cast off and replaced by others. The general health depends directly upon the activity of this process and the perfection with which it is performed. The pabulum or food which is needed by all the organs and tissues of the body for their repair or for their growth and development is carried to them by the blood. At every moment of our lives, whenever we make a movement, draw a breath, change a muscle of expression, conceive a passing fancy, certain cells die and are disintegrated, as a consequence. They become useless, and must be removed and carried to organs whose function it is to eliminate them from the body; new cells must be supplied to take their place. All this is done by the blood, which in performing this work becomes loaded with effete and useless material, much of which in the shape of carbonic acid is thrown off by the lungs. Now, this process is going on incessantly at every imaginable point in the human organism. Whether sleeping or waking, sitting or standing, walking or running, the same successive causes and effects continue to follow one another in the same unbroken circle of physiological phenomena—motion or activity, temporary and molecular loss of vitality, death of certain cells or atoms, disintegration of those cells, their removal and ejection from the system by means of the lungs, the skin, and the kidneys, their replacement by others brought by the blood, renewed vital power, and then further motion or activity, with the same succession of events. Taken as a whole, these events make up "life," and, reducing the statement to the simplest possible terms, we may say that the health and strength of any individual are in direct proportion to the thoroughness and celerity with which these occurrences take place; that is, to the speed and accuracy with which the cells or atoms are removed and replaced, or, as MacLaren says, to their "newness." Consequently, we are able to understand how an agent of any sort which influences these processes favorably must be one which will promote at the same time the

destruction of the old cells and their rapid replacement by new ones; in other words, one which, while it hastens the molecular death of certain tissues, will at the same time send them an increased amount of material with which to repair damages, or which may even enable them to improve upon and add to the original structure. Now, when we look for such an agent, discarding drugs, of course, as inapplicable and injurious, and assigning food to its proper place as fuel which may be transformed into force but is useless alone and unassisted, we find that there is but one means within our reach for effecting this purpose safely, continuously, and healthfully, and that is exercise. By "exercise" is meant certain movements made by means of the contraction of the voluntary muscles, and made with sufficient force and rapidity to quicken the breathing and the circulation of the blood, that is, to augment the action of the involuntary muscles concerned in those functions, chiefly the heart and the diaphragm. We understand what exercise thus essentially means. The force which moves the muscles employed in exercising is derived from the death or burning up of some of the cells of the body; this creates a need for the introduction of more oxygen into the system to unite with the carbon of these cells and produce this combustion; this increased quantity of oxygen is supplied through the lungs, which consequently have to expand much oftener than usual to meet the demand. This is the physiological and easily understood explanation of the fact that exercise is accompanied by quickened breathing. The increase that takes place in the quantity of air inspired under a variety of movements has been estimated as follows: Taking the amount of air inhaled at each breath in the recumbent position at 1, it rises on standing to $1\frac{1}{2}$; on walking at the rate of one mile an hour, to 1.9; at four miles an hour, to 5; riding at a trot raises it to 4.05; and swimming to 4.33. But it must be remembered that this oxygen thus brought to the lungs by the increased quantity of air inspired can be carried to the cells in the various tissues where it is needed only by the blood, which must, therefore, itself be sent to the lungs in greater amount to receive the oxygen and to give up the carbonic acid with which it is laden; in other words, when we exercise we not only breathe more quickly, but the heart beats more rapidly and forcibly. To make a similar comparison, we may say that while lying down the heart will beat 65 or 70 times a minute; on standing, 75 to 80 times; on walking slowly, 80 to 90 times; during fast walking, 90 to 100 times; and during or immediately after great physical exertion, as a boat-race or a running-match, from 115 to 125 times a minute.

These, then, as Ralfe has pointed out, are the two important facts to be remembered about exercise: that it increases the breathing-power, rids us of carbonic acid, and purifies our blood; and that it increases the action of the heart, sending a larger quantity of this purified blood to all the tissues of the body, removing their waste, supplying the material for their renewal, and quickening all the vital processes.

Exercise thus fulfils all the conditions that we have seen to be necessary in an agent which is to increase strength and health. As soon as any act of exercise is begun, a number of the voluntary muscles are put into action, their contraction compresses the blood-vessels and impels the venous blood actively towards the heart, which, thus spurred, contracts vigorously and sends the blood in increased quantity to the lungs. The inspiratory muscles contract and lift the bony frame-work of the chest, the diaphragm pushes down the contents of the abdomen, and air rushes into the lungs to fill the space thus produced and supplies the oxygen needed for the purification of the blood. This is then returned to the heart, to be distributed anew throughout the system, carrying with it the materials to supply the waste caused by the muscular movement originally made. These materials are often deposited in larger quantities than are required to counterbalance

the destruction which has taken place, and then we have the muscle growing in size, or in hardness, or both. The involuntary muscles also, including the heart and diaphragm, grow stronger in the same manner, the pulsations of the heart during exercise becoming more forcible but at the same time slower and less obtrusive, showing that it does its work more easily, the increased activity of the circulation carries the blood in larger quantity not only to the muscles but also to *all* the organs of the body, and thus stimulates them to greater activity, strengthening the appetite, digestion, and nutrition, and causing a gain in weight; the larger amount of blood sent to the skin results in an increase in the quantity of perspiration, which carries with it much of the worn-out and useless or noxious material of the system, and thus adds to the resistive power of the economy against evil influences from without, such as bad air from ill-ventilated rooms or dirty streets; the bony frame-work of the chest, though elastic, does not quite go back to its original dimensions, but, increasing a little at a time, soon becomes noticeably augmented in size, giving additional room for the important organs which it contains and protects.

These, then, are the effects of exercise—the most obvious but least useful being an increase in the size and power of the voluntary muscles, the more important being a strengthening of the involuntary muscles concerned in the processes of respiration and circulation, which enables us to use the increased power of the voluntary muscles with comfort and safety, and to influence through these processes not only the health and strength but also the growth and development of the whole body, and even the activity and force of the mental processes.

No system of exercise or of physical education is complete unless it recognizes the necessity which exists for attending to the *symmetrical* development of the contraction of the voluntary muscles, and the body. If, for example, a typical rowing-man, one who has been exclusively an oarsman, is carefully examined, it will be seen that his hips and thighs are developed at the expense of his calves; that the muscles of his back and loins are far stronger than his chest muscles; that his back arm and forearm somewhat exceed in development and hardness the front arm, though neither is noticeably developed. This condition indicates the proper exercises with which to supplement rowing in such a man, which will round him out, complete his development, add to his symmetry, and increase his general health and efficiency. He needs, obviously, running for his legs, the parallel bars for his chest, the rings or ladder for his upper arm; and this would be the advice which he would receive from a careful and intelligent trainer, to his great advantage not only as a man or an athlete but also as an oarsman. Further examples might be drawn from athletic sports to illustrate the general and important truth that no one exercise (nor, indeed, any series of the recreative and competitive exercises alone) will give complete and symmetrical development.

It is with this fact in mind that the systems of physical education now in use at Harvard, the University of Pennsylvania, and other American colleges, and long used at Oxford, have been devised, the plan being approximately as follows:

Each student is stripped and carefully examined as to his weight, height, the circumference of his chest, and the size and condition of his legs, thighs, arms, and forearms. The sum of these measurements, expressed in any convenient terms which may be selected, centimetres or feet, for example, is taken as an approximate indication of his development. It indicates, that is, with more or less accuracy (and particularly in men of immature years, in whom there is but little subcutaneous fat), the amount of working material which he possesses, though it fails to show the actual working value of that material.

Having recorded the development, the examiner proceeds to estimate the total available strength, and for this purpose applies a series of tests which show the strength and capacity of the lungs, and the strength respectively of the back, legs, thighs, arms, and chest, forearms and abdominal muscles. The sum of these is expressed in the same terms as those indicating the development, and can readily be compared with it. If the strength is in excess of the development, the condition is good, and the figures representing it have a plus value; if the reverse is the case, the condition is poor, and the figures have a minus value. The personal and family history is also ascertained and recorded.

The examiner is now in position to give advice, if it is required, upon a number of important topics. He can point out to the man inclined to be pigeon-breasted the value of the parallel bars or upright bars; he can suggest to the man with weak legs the rowing-machine or the river; he can instruct the man with the feeble or irritable heart to moderate his work, or can advise the man with flabby muscles, slow circulation, or undue accumulation of fat, to become more active in his exercises. He can go further than this, if need be, and can point out the proper diet to those of gouty or rheumatic parentage, the proper clothing to those inheriting a tendency to pulmonary trouble, and in fact can apply the general rules of hygiene or of preventive medicine to each individual case, with the advantage derived from the previous thorough and scientific inspection. It would be well, indeed, if every person in the community submitted to a similar examination by his family physician and received similar instruction. The effect of such a course in warding off preventable disease could hardly be overestimated.

These examinations are repeated from time to time, and the changes carefully noted. It has already been conclusively shown that not only are greater feats of strength accomplished when this system is properly followed, but that they are done with vastly greater ease and safety, owing to the symmetrical development of all parts. Tables made out at Harvard by Prof. Sargent (whose excellent papers on the subject are well worth study) and extending over five years show, for instance, taking the average of ten men as to "condition," and expressing the result in figures, that whereas in 1880 their strength was in excess of their development as 126 to 100, in 1884 the proportion had risen as 476 to 100; in other words, their condition in 1880 being taken at 126, it had in four years increased to 476, or nearly fourfold. The improvement may be made more readily comprehensible, perhaps, by taking a special example of physical exertion. In 1880 there was not a man among them who lifted over 393 pounds: that was the maximum. In 1884 the maximum was 675 pounds, while the minimum was 427, or 35 pounds more than the maximum of the first year. The concomitant improvement in health and vitality cannot be expressed in figures, but was no less marked.

This is the sort of athletic work which it seems most worth while to preach or prescribe to the world. Competitive athletics, though far less dangerous and much more beneficial than is generally supposed, cannot, for want of time and opportunity, be indulged in by the majority of men who have entered upon the real work of their lives. In college students their undue encouragement is objectionable on account of the one-sided and partial development which they bring, and because of the frequent distraction from college duties which they cause when the spirit of rivalry is allowed to become extreme. It is desirable to foster and preserve the manly games and sports in which for centuries it has been the pride of the Anglo-Saxon race to excel and to encourage their spread, not only among the students of our schools and colleges, but among the dyspeptic, nervous, and over-worked professional and business men produced in such enormous numbers by the

strain and hurry and exciting competition of our modern life. But, at the same time, the evils which surround these sports should be avoided, the risk of strain from lack of proper preparation, *i. e.*, of rational "training;" the risk of developing the competitive element until all things are sacrificed for success in one particular direction or event; the danger—especially to be guarded against in our colleges—of introducing the spirit of "professionalism" which looks rather at the prize now than at the means by which it was obtained; which abounds in quibbles and wrangles and unkind feeling; which reduces the masses to the position of spectators and develops a few specialists instead of a large number of general athletes. It should be understood that the main object and idea of exercise is the acquirement and preservation of health; that it is by far the most important therapeutic and hygienic agency at the command of the physician of to-day; that it can be prescribed on as rational a basis with as distinct reference to the correction of existing troubles or the prevention of threatened ones as any of the drugs of the pharmacopœia; that it increases not only the muscular strength and vitality but also the activity and vigor of the brain; that it augments incalculably the working power of the individual, and that it enables him, by means of the health and strength which it confers, not only to do better work than his business or professional rival who lacks these attributes, but also to do it more easily and safely, with the greatest amount of comfort and pleasure and the highest degree of usefulness to mankind. (J. w. w.)

PHYSICK, PHILIP SYNG (1768-1837), physician, was born at Philadelphia, July 7, 1768. His father had charge of the estates of the Penn family. After being taught at the Friends' Academy, he went to Europe to study medicine, and was private pupil under John Hunter. He was made house-surgeon to St. George's Hospital, obtained a diploma from the Royal College of Surgeons, and graduated at the University of Edinburgh in 1792. Returning to Philadelphia, he was soon made physician of the yellow-fever hospital during the epidemic of 1793, and one of the surgeons of the Pennsylvania Hospital. In 1805 he was made professor of surgery in the University of Pennsylvania, and in 1819 was transferred to the chair of anatomy, which he held for twelve years. He stood in the foremost rank of his profession as a surgeon, and was exceedingly popular as a lecturer. He was honored with membership in several medical societies of Europe. His only publications were in the medical journals. He died at Philadelphia, Dec. 15, 1837.

PIANO. The general history and construction of the pianoforte are treated at length in See Vol. XIX. the ENCYCLOPÆDIA BRITANNICA. This p. 64 (p. 72 article will therefore be confined to piano Am. Rep.). manufacture in America. The piano was already known and manufactured in Europe when this nation was still in its infancy. Yet the inventive genius of the American, once applied to this instrument, accomplished as much towards perfecting it as all the other nations put together. It is generally supposed that Benjamin Crehore, of Milton, Mass., made the first piano produced in this country. This was about at the beginning of the present century. Adam and William Bent were making pianos in Boston as early as 1803. In 1810 the brothers Alpheus and Lewis Babcock, who had learned their trade with Crehore, joined with Thomas Appleton and the Hoyts, music dealers, under the firm-name of Hoyts, Babcocks & Appleton. After the war of 1812 the Hoyts went to Buffalo, John Mackay taking their place. The firm was dissolved about 1820. John Osborne worked with this firm, and subsequently set up for himself, and with him Jonas Chickering (1797-1853) and Timothy Gilbert worked as journeymen. James Stuart, a Scotchman, who had the reputation of making an excellent piano, was associated for a time with Osborne, and later with Chickering. After the firm of

Hoyts, Babcocks & Appleton had been dissolved, John Mackay was associated for a few years with Alpheus Babcock. In 1830 Mackay formed a partnership with Jonas Chickering, which lasted until his death in 1841. Chickering had started in business for himself in 1823. He soon began introducing the improvements which have made his name famous, and the rapid perfection of the American piano is in a large measure due to him. Alpheus Babcock, of Boston, who afterward, and until his death, was foreman of the Chickering factory, had, in 1825, patented a cast-iron frame for square pianos. In 1833 Conrad Meyer, of Philadelphia, also exhibited a piano with a full cast-iron frame. Babcock's plan of construction was greatly improved and modified by Chickering, who, in 1837, made his first square piano with a complete iron frame, and three years later the first grand piano ever made with a full iron frame. About 1843 he took out a patent on an invention of great importance. This was the introduction of a cast-iron flange on the top of the plate covering the head-block, which flange was drilled for each string to pass through. This gave the strings a firm tendency upwards, and served at the same time as a transverse strengthening-bar. When grand pianos of this construction were sent to the International Exhibition of 1851, in London, they attracted considerable attention, and were awarded a prize medal. In 1856 this method of construction was superseded by the "agraffe" system now in use. According to this a solid iron flange is cast on the under side of the iron frame, into which the "agraffes" are screwed. In 1845 Chickering invented and first used the circular scale for square pianos. The improvements mentioned are only the most important of those introduced by him. After his death, in 1853, the business was carried on by his sons, under the old firm-name, Chickering & Sons. They have a large branch house in New York, in the same building with the well-known "Chickering Hall." The number of pianos that have come from their factory is about 75,000. The originator of the system of "overstringing," which Chickering did not adopt until 1853, is, it seems, not known. It has been claimed, however, that the first piano on this plan made in America came from the factory of John B. Dunham.

Among Chickering's competitors in Boston were Lemuel and Timothy Gilbert, and about this time a number of piano-makers were beginning to work in Albany. Among the first were Boardman & Gray and James A. Grovesteen. Later came Meecham & Pond, John Osborne, and others. Grovesteen went to New York in 1843, and retired from business in 1886. The prominent firms in New York at this time were R. & W. Nunn, who enjoyed an excellent reputation; Stoddart, Worcester & Dunham; Firth, Pond & Co., later Firth, Hall & Pond (the same Pond who was associated with Meecham in Albany); Bacon & Raven (established about 1840); William H. Gieb & Co.; Linden & Fritz, and Lindeman & Sons (established 1836). Henry Hazleton was an apprentice with Dubois & Stoddart in 1831. He and his brother were for a time with Bacon & Raven, but began business soon after that firm was established. When, some time before 1840, William Nunn left R. & W. Nunn, Charles S. Fischer entered the firm, which changed its name to Nunn & Fischer. Later, he and his brother, John W. Fischer, began conducting business together, under the name of J. & C. Fischer, by which the firm is still known. Frank and Napoleon J. Haines were apprenticed in 1839 to the N. Y. Pianoforte Manufacturing Company, and, in 1851, started in for themselves. One of our earlier musicians, William B. Bradbury, also began to manufacture pianos in 1854, in partnership with his brother, E. G. Bradbury.

A house that has played a prominent part in the growth and development of piano-making in this country is that of Steinway & Sons. Henry Engelhard Steinway (originally Steinweg), the founder of the firm,

was born in Germany in 1797. He was originally an organ-builder, but soon began making pianos on a small scale, exhibiting some as early as 1839. In 1850 he came with his family to New York, where, three years later, he established the house which bears his name. The business increased very rapidly, and, after repeated removals, the firm finally settled in its present quarters in 1863. Three years later the well-known concert-room, "Steinway Hall," in the same building, was opened to the public. In 1875 a branch house was opened in London, England, and in 1880 another in Hamburg, Germany. Charles and Henry, two of the sons, died in 1865, and the father in 1871. The business is now carried on by William Steinway, C. F. Theodore Steinway, and some younger members of the family. The firm has patented a number of inventions, among which the overstrung scale (1859); an agraffe arrangement for square and grand pianos (1859); the duplex scale (1872); and the tone-sustaining pedals (1874-75). Their instruments take high rank, and have gained honors whenever exhibited, notably at London in 1862 and 1885, and in Paris in 1867.

In 1833 William Knabe (1803-64) came to this country, and began to work in Baltimore, first under Hartge, and later alone. He and H. Gaeble went into partnership in 1839, under the name of Knabe & Gaeble, and when Gaeble died in 1855 Knabe continued the business, under the name of William Knabe & Co. This name it still bears, his sons, William and Ernest, and his son-in-law, Charles Keidel, constituting the present firm. The house manufactures a first-class piano, and its instruments are much in demand.

Another well-known house is that of Weber, also founded by a German. Albert Weber came to the United States in 1845, settling in New York. Seven years later he started in business for himself, but it was not until about 1871 that the business began to assume the large proportions to which it subsequently grew. When Weber died in 1879 he was succeeded by his son, Albert Weber, Jr., who, the following year, opened a branch house in Chicago. The house of George Steck & Co., of New York, was established in 1857 by George Steck, the senior partner. Among the improvements which Mr. Steck has introduced is one patented in 1870 in the frame of upright pianos. His instruments are favorably known, both in this country and Europe. One of the younger firms is that of Sohmer & Co., founded in 1872 by Hugo Sohmer and Joseph Kudor. They also have introduced several improvements in construction, among which the improvement of the "Allicot" system, by which they place the auxiliary tone-re-enforcing string above the other three, and arrange all the tuning-pins on one side. They have patented also an improved agraffe-bar for the upper three octaves of squares and grands (1882), a pianissimo pedal (1887), and an action in upright pianos for obtaining quick and certain repetition (1882). The firm gives much attention to upright pianos, in which it excels.

The firm of Decker Brothers, of New York, established by the brothers, David and John Jacob Decker, in 1862, has also introduced several notable improvements, and is still adding to its reputation. Myron A. Decker (not related to the members of the preceding firm) began business in Albany in 1856, and four years later came to New York. Here he worked for seventeen years, sometimes alone, sometimes in partnership with others, until, in 1878, he and his son formed the present firm of Decker & Son. Other firms of greater or less repute at the present day are Kroeger & Sons (Henry Kroeger came to New York in 1855, and was superintendent under the Steinways for 24 years); Ernest Gabler & Bro. (established 1854); Kranich & Bach; Calenberg & Vaupel (established 1858); Krakauer Bros.; Mathushek Piano Manufacturing Company; Vose & Sons (established 1851); F. Bräutigam; F. Schuler; Behning; and Behr Bros. & Co. (founded in 1881), all of New York. The Henry F. Miller &

Sons Piano Company, of Boston, Mass., was organized in 1884, succeeding Henry F. Miller, who had established himself as early as 1863; the Emerson Piano Company, and the Ivers & Pond Piano Company, also have their head-quarters in Boston. Many others, too numerous to name here, have arisen within recent years. The Mason & Haulin Organ and Piano Company deserves mention for the new method of stringing it has introduced. By this system, which was patented in 1883, the strings are secured by metallic fastenings directly to the iron frame, instead of winding them around wrest-pins set in wood as in the old system.

The business of piano-making in this country is continually assuming larger proportions, and new firms continue to spring up. Naturally, a certain percentage of the work produced is cheap and poor. But on the whole the many useful improvements made in the construction of the piano by American manufacturers have served to make their instruments superior in many ways to those produced in Europe. (F. L. W.)

PIATT, JOHN JAMES, poet, was born at Milton, Dearborn co., Ind., March 1, 1835. Taken in boyhood to Columbus, Ohio, he became a printer. In 1856 he removed to Illinois and soon began to contribute poems to the *Louisville Journal*, whose editor, G. D. Prentice, proved a steadfast friend. In 1860 Piatt and W. D. Howells published at Columbus *Poems of Two Friends*. In 1861 Piatt removed to Washington, having been appointed clerk in the U. S. Treasury Department. In 1867 he engaged in newspaper work in Cincinnati, but in 1870 he returned to Washington as clerk in Congress, and two years later was made librarian of the lower House. In 1882 he was appointed U. S. consul at Cork, Ireland. His publications are *Nests at Washington* (1864); *Poems in Sunshine and Firelight* (1866); *Western Windows* (1869); *Landmarks and other Poems* (1871). The later volumes contain old retouched as well as new poems. His uncle, DONN PIATT, born in 1829, rose to the rank of colonel in the civil war, and is noted as a journalist.

J. J. Piatt's wife, SARAH MORGAN BRYAN PIATT, born near Lexington, Ky., Aug. 11, 1836, was educated at Henry Female College, Newcastle, Ky., and early wrote poems for the *Louisville Journal*. She was married in 1861, and some of her early poems were published in *Nests at Washington* and others in *A Woman's Poems* (1871). Her poems are thoughtful and deep in sentiment, but sometimes obscure.

PICKENS, ANDREW (1739-1817), general, was born at Paxton, Bucks co., Pa., Sept. 19, 1739. His parents, who were of Huguenot descent, removed to South Carolina in 1752. In 1761 Andrew served in an expedition against the Cherokees, and at the outbreak of the revolution he was made captain of militia. Throughout the struggle he displayed patriotic zeal, and rose to the rank of brigadier-general. In February, 1779, he defeated a band of Tories under Col. Boyd at Kettle Creek; in June he covered the retreat at Stono Ferry, and later in the same year defeated the Cherokees at Tomassee. For his part in the battle of Cowpens, Jan. 17, 1781, see COWPENS. He had command of the Carolina volunteers at Eutaw Springs, Sept. 8, 1781. He made an expedition against the Cherokees in 1782, which resulted in the cession of a large territory. He was afterwards member of the State Legislature (1783-94), then member of Congress for a single term, and major-general of militia. He took part in negotiating several treaties with the Indians. In 1765 he married Rebecca Calhoun, aunt of John C. Calhoun. He died in Pendleton District, S. C., Aug. 17, 1817.

His son, ANDREW PICKENS, became governor of South Carolina in 1816, and died in 1838. FRANCIS W. PICKENS (1807-1869), son of Andrew, was noted as a Secession leader. Educated at South Carolina College, he was a lawyer and first obtained note as a speaker in

the Legislature during the nullification excitement in 1832. He maintained that Congress, being a creature of the States severally, had no sovereign power. In 1835 he was elected to Congress, and there he denied the right of Congress to abolish slavery in the District of Columbia. After ten years' service in the national legislature he was returned to the State Senate, where he opposed a movement for immediate secession. He took part in the Southern Convention at Nashville in 1850 and in the Democratic National Convention at Cincinnati in 1854. He was sent as U. S. minister to Russia in 1858, but returned to take part in the secession of South Carolina, of which State he was then chosen governor. He demanded the surrender of Fort Sumter from Major Anderson, and afterwards aided in every way the rebellion. He retired from office in 1862 and died at Edgefield, S. C., Jan. 25, 1869.

PICKERING, TIMOTHY (1745-1829), statesman, was born at Salem, Mass., July 17, 1745. He graduated at Harvard College in 1763, and became a lawyer at Salem in 1768. He was prominent in resisting the arbitrary measures of Parliament, and in 1774, on behalf of the people of Salem, he delivered an address to Gov. Gage on the occasion of the Boston Port Bill. While holding the office of judge, he published *An Easy Plan of Discipline for a Militia* (1775), which became the textbook of the State. He served in the revolution as colonel, and in 1777 was made adjutant-general by Washington, and in 1780 quartermaster-general. After the war he became a merchant in Philadelphia. In 1786 he removed to Wilkesbarre to organize the county of Luzerne and to settle the disputes which had arisen from conflicting claims of Connecticut and Pennsylvania to the Wyoming Valley. While acting in this capacity he was seized by persons in disguise, imprisoned and harshly treated for twenty days. He was sent as delegate of Luzerne county to the Pennsylvania Constitutional Convention of 1790. In Washington's administration he was postmaster-general (1791-94), then secretary of war (1794-95), and secretary of state (1795-1800). He had also been much employed in negotiating treaties with the Indians of New York and Ohio. Leaving office poor, he lived for a time in a log-house at Wyoming, but afterwards, by the sale of lands, was enabled to return to Salem, Mass., where he was made judge of common pleas. In 1803 he was elected to the U. S. Senate, being an ardent Federalist. During the war of 1812 he was a member of the board of war of Massachusetts. He was afterwards member of Congress for a single term, but retired from public life at the age of 72, though he remained president of the Essex Agricultural Society. He died at Salem, Jan. 29, 1829. His *Life*, left incomplete by his son Octavius, was finished by C. W. Upham (4 vols., 1867-73).

His oldest son, JOHN PICKERING (1777-1846), philologist, was born at Salem, Feb. 17, 1777, accompanied his father in his visits to the Six Nations of New York, and was thus led to investigate the Indian languages, to which he devoted much attention throughout life. After graduating at Harvard in 1796 he spent some time in diplomatic service at Lisbon and London, and was afterwards a lawyer at Salem. From 1829 till his death, on May 5, 1846, he was the city solicitor of Boston. His chief publications were on philological subjects, and include, besides treatises on the Indian languages, a *Vocabulary of Americanisms* (1816) and a *Greek and English Lexicon* (1826), which reached a third edition before his death and was long held in high esteem. He was the founder of the American Oriental Society and president of the American Academy of Arts and Sciences.

Another son, OCTAVIUS PICKERING (1792-1868), born in Wyoming Valley, Sept. 2, 1792, graduated at Harvard College in 1810, and became a lawyer at Boston. He was State reporter from 1822 to 1840, publishing 24 volumes of *Reports*. He afterwards lived in Europe for some years and died at Boston

Oct. 29, 1868, leaving his father's biography unfinished.

CHARLES PICKERING (1805-1878), naturalist, grandson of Timothy, was born in Susquehanna co., Pa., Nov. 10, 1805. He graduated at Harvard College in 1823 and obtained his medical degree in 1826. After some years' practice at Philadelphia, where he was also active in the Academy of Natural Sciences, he went in 1838 as naturalist on the Wilkes exploring expedition. He also travelled in India and Eastern Africa, examining the different tribes. The result of his researches was given in his *Races of Men and their Geographical Distribution* (1848; vol. ix. of Wilkes' Report); *Geographical Distribution of Animals and Plants* (1854; vol. xix. of Wilkes' Report); and *Geographical Distribution of Plants* (1861). He afterwards lived a very retired, studious life at Boston, where he died March 17, 1878. After his death appeared his *Chronological History of Plants* (1879), a laborious but unsystematic work, cumbered with useless learning.

EDWARD CHARLES PICKERING, physicist, great-grandson of Col. Timothy Pickering, was born at Boston, July 19, 1846. He graduated at the Lawrence Scientific School in 1865, and was chosen professor of physics in the Massachusetts Institute of Technology in 1867. He took part in observing the solar eclipse of 1869 in Iowa and that of 1870 in Spain. He has made extensive researches in optics and in the polarization of light, and has published *Physical Manipulation* (1874).

PICKETT, ALBERT JAMES (1810-1858), historian of Alabama, was born in Anson co., N. C., Aug. 13, 1810. He removed in boyhood to Autauga co., Ala., and became a lawyer. He took part in the Creek war, and became a colonel. His only publication was his *History of Alabama* (2 vols., Charleston, 1851). He died at Montgomery, Ala., Oct. 28, 1858. C. M. Jackson published a brief biography.

PICKETT, GEORGE E. (1825-1875), a Confederate general, was born at Richmond, Va., Jan. 25, 1825. Graduating at West Point in 1846, he served in the Mexican war from Vera Cruz to the capture of Mexico, winning two brevets for gallantry. He was afterwards engaged in frontier duty until June 25, 1861, when he resigned to enter the Confederate service. In the defence of Richmond in 1862 he commanded a brigade, and was severely wounded at Gaines's Mill. Rejoining the Army of Northern Virginia as major-general, he was conspicuous for courage, skill, and zeal. At Gettysburg, July 3, 1863, he led the famous final assault on the Union lines (see **GETTYSBURG**). Gen. Pickett afterwards commanded in North Carolina, where he captured Plymouth. At the opening of the campaign in 1865 his division was engaged in protecting the Southside Railroad, near Richmond, but was surrounded and overwhelmed at Five Forks, April 1, 1865. Gen. Pickett died at Norfolk, Va., July 30, 1875.

PIERCE, GEORGE FOSTER (1811-1884), bishop of the Methodist Episcopal Church, South, was born in Greene co., Ga., Feb. 3, 1811, being the son of Rev. Dr. Lovick Pierce (1785-1879), a noted pulpit orator. After studying law he joined the Georgia Conference in 1831, and was engaged as an itinerant in Georgia and South Carolina. He was prominent in the General Conference of 1844, when the Methodist Church was divided on the slavery question. In 1848 he was made president of Emory College, and was ever active in promoting its financial interests. In 1854 he was chosen bishop, and found a wider field for his executive abilities. He was also noted as an orator, edited a magazine, and published many sermons. His only book was *Incidents of Western Travel* (1857). He died Sept. 3, 1884.

PIERPONT, JOHN (1785-1866), clergyman and poet, was born at Litchfield, Conn., April 6, 1785, being descended from Rev. James Pierpont, the second

minister of New Haven and a founder of Yale College. Here John graduated in 1804, and then went to South Carolina as a tutor in the family of Col. William Allston. Returning to the North he became a lawyer in 1812, but soon engaged in unsuccessful mercantile enterprises with John Neal (*q. v.*) at Boston and Baltimore. In 1819 he was ordained minister of Hollis Street Unitarian Church, whence he passed to Troy, N. Y., in 1845, and thence to Medford, Mass., in 1849. He was an earnest anti-slavery and temperance orator, and obtained public favor by his poetic addresses. The most noted of these was *The Aims of Palestine* (1816), which set forth the associations of music with natural scenery and national character. At the centennial celebration of his native place he gave a humorous sketch of Yankee character. In 1861, true to the anti-slavery zeal of younger days, he accepted the chaplaincy of a Massachusetts regiment, but was soon transferred to a clerkship in the U. S. Treasury, from which he retired in 1864. He died at Medford, Mass., Aug. 27, 1866. A collection of his *Poems* appeared in 1854, and he also published some school-books.

PIERREPONT, EDWARDS, lawyer, was born at North Haven, Conn., March 4, 1817. Graduating at Yale College in 1837, he was admitted to the bar in 1840, and practised for some years at Columbus, Ohio, but removed to New York city in 1846. He was elected judge of the superior court of New York in 1857, but resigned in 1860 and resumed practice at the bar. In 1862 he was appointed, with Maj.-Gen. John A. Dix, to try the prisoners of state held on various charges growing out of the Rebellion. In 1867 he served in the New York State Constitutional Convention, especially on the Judiciary committee. He also conducted for the U. S. government the prosecution of John H. Surratt for complicity in the assassination of Lincoln. In 1869 Pres. Grant appointed him U. S. attorney for the southern district of New York, which office he resigned in May following. In 1875 he was called into Pres. Grant's cabinet as attorney-general of the United States, and in May, 1876, was sent as minister to England. He resigned this office in December, 1877. He published *From Fifth Avenue to Alaska* (1884).

PIG. See **SWINE**.

PIGEON. See **FOWL**.

PIGMENTS. The mining and manufacture of pigments in the United States have been of steady growth, and although there was for many years a strong prejudice in favor of imported pigments, this has given way to a fair appreciation of the home products, until now both the imported and domestic are sold on their merits, and as nearly all of domestic productions compare favorably with the imported, the former are consumed in yearly increasing quantities; our imports show little variation from year to year on most pigments, while a few show a decrease. In considering articles properly classed under the name "pigments," only such are treated as are manufactured or produced in the United States in commercial quantities.

Barytes.—The heavy spar from which this article is made is found in many sections of the country, but the principal sources of supply are Missouri, Virginia, North Carolina, and Tennessee. As its principal use is as a substitute or adulterant in the manufacture of paints, both dealers and manufacturers withhold all information as to the amount of production and use. The total amount produced, however, may be estimated as approximating 50,000 tons annually. Its principal use is in the adulteration of white lead and in the manufacture of mixed paints, and as a weighting material for various purposes. Owing to its great weight and its dazzling whiteness, it is regarded as the best adulterant of white lead, and on that account not liable to detection. It is also largely employed as a weighting substance by paper-makers and others. Barytes is also imported from Germany, England, and

Canada. Artificial barytes, commercially known as "blanc fixé," is a mixture of crude heavy spar and other materials, and is superior to natural barytes as a pigment, having greater covering capacity. It is largely employed by paper and card manufacturers. The amount imported is about equal to that made here. There is no difference in the quality, although the imported realizes a higher price.

Litharge.—See article WHITE LEAD.

Ochre.—In commerce only the lighter shades of hydrated peroxides of iron are known as ochres; the darker shades, notably the browns and reds, are designated as "metallic paints." Ochres are found in many States, but the best are found in Virginia, Pennsylvania, Missouri, Georgia, and South Carolina. Some of these deposits contain various colors and shadings, but not all are valuable as pigments. The more common grades are used by floor-cloth manufacturers in the preparation of the body of the cloth. Of the grades used as a pigment about 10,000 tons are annually mined and sold. Ochres are imported from France, and these are preferred by manufacturers of paints as they require less oil for grinding, and are consequently more economical in the manufacture of "mixed paints."

Red Lead.—See article WHITE LEAD.

Sienna.—There are many deposits of this clay in the United States, but most of them are of inferior quality. The mines are in Pennsylvania, New Jersey, Maine, and Virginia, the quality of product ranging in this order. Painters prefer the imported, and although double the price of the domestic, Sicily sienna is imported in yearly increasing quantities.

Terra Alba.—The gypsum used to produce this article is imported from Nova Scotia, but what proportion of the total quantity is used in the manufacture of paints is not known. The terra alba made from gypsum mined in the United States is used as an adulterant for many articles, as also by paper-makers and others as a weighting substance. Fine grades of terra alba are imported from France and England, though only in limited quantities.

Ultramarine.—In commerce, the artificial product has received this name and the pigment product of lapis lazuli is scarcely known except to the artist, while its high cost excludes it from most studios. Only three firms are engaged in the manufacture of ultramarine, two factories being located in the State of New Jersey and one in New York. The annual production of these works amounts to about 2000 tons. For some years after the manufacture of this pigment was established in the United States, there existed a strong prejudice against it, and fully double the price asked for the domestic product was obtained for that imported from Germany. It was not until the year 1880 that the first manufacturer began to realize a fair reward for his perseverance in introducing American ultramarine, which from the beginning was equal to the best imported.

Umber.—The only States from which umber is obtained are Pennsylvania and Vermont, the former supplying fully five-sixths of the total of about 1500 tons annually marketed. In all respects except color the American umber is the equal of that imported from Turkey, while the price is much lower. The imported is of a rich, reddish-brown, while the American inclines to gray. An artificial umber, made by mixing certain mineral pigments, and which in color is a good imitation of Turkey umber, is sold as the genuine imported.

Vermilion.—The manufacture of this pigment in the United States is controlled by a combination of manufacturers which regulates the price, the amount of production, and the trade in the article. The process of manufacture being one of extreme difficulty and requiring great skill, the process is kept secret and the manufacturers, not over six in number, are enabled to prevent competition, having successfully checked at-

tempts to establish new plants which have at different times been in contemplation. The manufacture of this artificial sulphide of mercury is made a specialty of manufacturers of other pigments and paints, the amount consumed being too small to make its manufacture profitable as a separate industry. The amount manufactured varies from year to year, averaging about 800,000 pounds, but does not show the increase which is noticeable in the consumption of most other pigments. This is due to the introduction of substitutes known as vermilion, but not made from quicksilver. The genuine quicksilver vermilion is commercially known as "quicksilver," "English," or "California" vermilion. The imports of English vermilion do not increase, the American product being equal to the imported in every respect, and by many regarded as superior. A number of pigments are on the market, known as vermilion but not made from quicksilver, and these have a large sale, owing to their low market price. The principal of these, "American vermilion," "Persian red," "Persian scarlet," "scarlet vermilion," etc., are chromates of lead. Of these fully 1,000,000 pounds are produced and sold annually. Other cheap substitutes are aniline colors which, instead of growing darker on exposure as is the case with quicksilver vermilion, grow lighter. As their color is brilliant they have become popular and their sale has steadily increased until at the present time their consumption equals that of the genuine. These aniline imitation vermilions are sold under various names, the better known being "Roman red," "Swiss red," "Columbian red," "rubeide," etc. The relative value of these several vermilion pigments is not easily stated, but true quicksilver vermilion is superior in body, richness, and permanency. The chromates of lead lack body, are not so rich in color, but have the compensating quality of greater permanency and extreme cheapness. The aniline vermilions have good body, are even more brilliant than the quicksilver vermilion, but their grave fault is the fugaciousness of the color.

White Lead is treated in a special article, which see.

Whiting and Paris White.—The manufacture of whiting is confined to the cities of New York, Brooklyn, Philadelphia, and Boston. The material used, chalk, is all imported from Hull, England, whence it is brought as ballast in sailing vessels. The annual production is from 300,000 to 350,000 barrels. Paris white is made from English cliffstone, a variety of limestone, which is imported from England. From 4000 to 4500 tons are annually used. About 300 tons of Paris white are imported from England.

Zinc White.—The oxide of zinc, known as zinc white, ranks second in importance as a pigment. It is extensively employed in the manufacture of mixed paints, and is especially esteemed for indoor painting, owing to the purity and brilliancy of the color. It is made directly from the zinc ore by several firms in New Jersey, Pennsylvania, Missouri, and Wisconsin. The consumption has increased steadily and has now reached about 25,000 tons, only about 2000 tons being imported. The French zinc white is regarded as superior to the American in purity of color, and the German is preferred by others for no well-defined reason. Fully 20,000 tons are annually used as a pigment, while 5000 tons are consumed by manufacturers of paper, rubber, and pottery. New York city is the principal market.

(H. G. A.)

PIKE, the strongest and most voracious of fresh water carnivorous fish, comprising the genus *Esox*, the only genus of the family *Esoxidae*. The pikes are well represented in the waters of the United States.

there being five or six species, while only one species is found in Europe and Asia. The *Esoxidae* are soft-rayed abdominal fishes, with long bodies, having but one dorsal fin, opposite the anal. The mouth is large, with a wide gape, and is plentifully supplied with teeth.

The skeleton, especially the skull, is remarkably soft, and Agassiz assigns them to a low place among abdominal fishes. The body is covered with scales, barbels are wanting, the margin of the upper jaw is covered by the intermaxillaries mesially and by the maxillaries laterally, the stomach is without blind sac, the air bladder simple, and the gills open very wide.

Of the American pikes the largest is *Esox Estor*, the Muskallonge or Maskinonge (Canadian-French *Musque-allongé*, long face or snout). This species is found only in the Great Lakes and the waters of the St. Lawrence basin. It grows to the length of 3 feet, and is said to occur in Lake Champlain of over 4 feet in length and of 40 lbs. weight. This fish is of a deep greenish-brown hue on the back, while the sides have numerous rounded pale yellow spots, and the abdomen is white, the fins being of a reddish-yellow color with dark green marbling. The snout is very long and acute, the borders of the upper jaw being formed of the maxillaries alone, their edges furnished with several rows of long, powerful, and very sharp, awl-shaped teeth. The lower jaw is considerably longer than the upper, and is armed for less than half its length with powerful, recurved teeth, the two largest in front. The head and body are flattened above and much compressed at the sides, the dorsal fins directly above the anal, the caudal powerful and deeply forked.

This is the boldest, fiercest, and most voracious of all fresh-water fishes, making havoc among all other tenants of the waters it inhabits, none, perhaps, except the great lake trout, being able to resist its attacks. Even the spring dorsal fins of the perch are said to not afford protection from the pike. It bites daringly at dead bait, and is said to be easily taken even by a bait of tin or red cloth made to play briskly through the water. The European pike, *E. lucius*, is closely related in specific character to *E. estor*. It attains 3 feet in extreme length, is found in most of the rivers and lakes of Europe, and is much angled for, the flesh being well esteemed for table use.

The smaller species of American pike are commonly known as pickerel. There are several of these, the largest being *E. lucioides*, a fish which, like *E. estor*, is peculiar to the basin of the St. Lawrence. It is from one to two feet in length and rarely exceeds 16 or 17 lbs. weight, and is a handsome fish, with a four-sided body, longer and sligher in proportion to its depth than in the Muskallonge. The snout is not nearly so long and much more obtuse than in the latter, the under jaw being less elongated, and armed with a single row of small teeth round the fore part, with large, awl-shaped teeth on the sides. The back is of a rich blackish-green color, the sides greenish-gray, the abdomen pearly white, there being several rows of diamond-shaped yellowish spots along the body and head. A bright speck on the tip of each scale gives a sparkling aspect to this fish. It is equal in boldness and voracity to the Muskallonge, attacks fish of every variety, even of its own species, and preys also on the young of wild fowls, rats, reptiles, or any small creature that ventures into its domain. It is generally taken with a hook baited with white flesh or other substance and moved rapidly over the surface. It is also readily caught in winter by spearing through holes in the ice. It formed an essential food-supply to the Indian hunters when short of other food in winter.

The common pickerel (*E. reticularis*) is perhaps the commonest of all game fishes in the north-eastern United States. It ranges from New England to Western Pennsylvania, and south perhaps to the hill-districts of Virginia. In size it is much below those above mentioned, being of an average weight of 2½ or 3 lbs. It has the elongated snout and curved lower jaw of the Muskallonge, and is in color olive-green on the back and greenish-yellow on the sides. It is more voracious if possible than the others, bites at any time of the day, and with the bait above or below water, drawn fast or slow. It darts on its prey with great force, its prominent

lower jaw serving as a defence against violent blows on the bottom of streams. The Long Island pike, *E. fasciatus*, is the smallest of the family, and of little value to sportsmen. It is remarkable for the great size of its scales as compared with the other species, whose scales are very minute. The name of pike is given to several sea-fish of the allied genus *Belone*, the European sea-pike, *B. vulgaris*, being known also as the mackerel guide, as it precedes the latter in their annual migration to their spawning-grounds. (C. M.)

PIKE, ALBERT, poet and general, was born at Boston, Dec. 29, 1809. When he was a child his family removed to Newburyport, and he began to teach after studying for a time at Harvard College. In 1831 he went to St. Louis, travelling mostly on foot, and then joined an expedition to Santa Fé. After further wanderings he settled in Arkansas, becoming editor, and in 1834 proprietor of a newspaper at Little Rock. He published (Boston, 1834) a narrative of his adventures and added to it several poems, suggested by the scenery through which he had passed. He became a lawyer in 1836, supervised the publication of the statutes of Arkansas, and published *Reports of the Supreme Court of that State* (1840-45). In the Mexican war he served as a volunteer, and at the outbreak of the civil war he recruited on behalf of the Southern Confederacy a force of Cherokee Indians, whom he led at the battle of Pea Ridge, March 7, 1862. On account of their scalping some of the fallen, the Confederate government caused the disbandment of this Indian force. After the war Gen. Pike edited the *Memphis Appeal* and in 1868 he removed to Washington. He has received the highest degrees in free-masonry, and has published the *Statutes and Laws of the Ancient Scottish Rite* (1859). His most noted poems are the *Hymns to the Gods*, composed before he left New England, published at Boston in 1831, reprinted in *Blackwood's Magazine* in 1839, and in his *Nugæ* (Phila., 1854, and later).

PIKE, ZEBULON MONTGOMERY (1779-1813), general, was born at Lambertton (now part of Trenton), N. J., Jan. 5, 1779. His father, Zebulon Pike (1751-1834), had been a captain in the Revolutionary army and afterwards in the regular army. The son was appointed cadet in his father's regiment in 1799, and soon promoted lieutenant. His mathematical skill led to his being appointed in 1805 to make a survey of the Upper Mississippi, which was accomplished in less than nine months. Being then made captain he was employed in exploring the newly acquired territory of Louisiana, and while thus engaged was arrested for invading Spanish ground, and carried to Santa Fé, where his papers were seized and examined. He was escorted across Texas and arrived at Natchitoches, July 1, 1807. The narrative of both expeditions is given in his book, *The Sources of the Mississippi and its Tributaries* (Phila., 1810), for which he received the thanks of the government. He was promoted colonel in 1812 and brigadier-general in March, 1813, when he was selected to command the expedition against York (now Toronto), the capital of Upper Canada. He sailed from Sackett's Harbor, landed under heavy fire, April 27, 1813, carried one battery by assault, and was moving on the main works when he was killed by the explosion of the magazine. Pike's Peak in Colorado preserves his name and fame. His *Life* was written by Gen. H. Whiting in Sparks's *American Biography*.

PILLOW, GIDEON JOHNSON (1806-1878), general and politician, was born in Williamson co., Tenn., June 8, 1806, being a grandson of John Pillow, a Revolutionary soldier, who had settled at Nashville in 1783. He graduated at the university of that city in 1827 and entered on the practice of law at Columbia, Tenn., in 1830. He assisted in the nomination and election of President Polk, by whom in July, 1846, he was commissioned brigadier-general. His brigade of Tennessee volunteers joined Gen. Scott's army at Vera Cruz, and took part in its capture. Pillow commanded

a division of the army in the march to Mexico, and was wounded at Cerro Gordo and Chapultepec. After entering the city of Mexico he had serious difficulties with Gen. Scott and was placed under arrest, but was released by orders from Washington. Returning to Tennessee he devoted himself to the management of his estate. In 1850 he was a member of the Nashville Southern Convention and opposed secession. In April, 1861, he undertook to raise troops in Tennessee for the Confederacy and was made major-general in the Confederate army. His conduct at FORT DONELSON is narrated under that head. Gen. Grant in his *Personal Memoirs* expresses a poor opinion of his worth as soldier and general. Pillow escaped to Nashville, and afterwards had some nominal command under Beauregard. He died in Lee Co., Ark., Oct. 6, 1878.

PILOTY, KARL VON (1826-1886), a German painter, was born at Munich, Oct. 1, 1826. He studied at the Munich academy and became manager of the lithographic institute founded by his father. He improved his knowledge of art by travels through Belgium, France, and England. His first painting, *The Dying Mother and the Nurse*, attracted attention to his merits. His next was *The Adhesion of the Elector Maximilian to the Catholic League*. After Piloty was made professor in 1858, he was quickly surrounded by a crowd of enthusiastic students, some of whom, Makart for instance, have since been acknowledged masters. On the death of Kaulbach, the direction of the Academy was assigned to Piloty. Among his noted works are *The Assassination of Wallenstein*; *Nero amid the Ruins of Rome* (1864); *Columbus Discovering America* (1865); *The Death of Julius Cæsar*; *Mary Queen of Scots listening to her Death Warrant*; *Thusnelda in the Triumph of Germanicus* (1872). At various international exhibitions he obtained the highest honors. He died July 21, 1886.

PINCKNEY, CHARLES (1758-1824), statesman, was born at Charleston, S. C., in 1758, being grandson of William Pinckney (1703-1766), commissary-general of South Carolina. He became a lawyer and on the capture of Charleston in 1780 was sent as prisoner to St. Augustine. He was afterwards elected to the State Legislature, to Congress, and to the Convention which framed the United States Constitution in 1787. In the next year he presided over the Convention which framed the State constitution and was governor of the State for several years. In 1798 he was chosen to the U. S. Senate, in which he advocated the principles of Jefferson. In 1802 he was sent as minister to Spain and there obtained a relinquishment of Spanish claims to Louisiana. Returning in 1805 he served chiefly in the State Legislature, but in Congress, 1819-21, he opposed the Missouri Compromise. He died at Charleston, Oct. 29, 1824.

His son, **HENRY LAURENS PINCKNEY** (1794-1863), was long a member of the South Carolina Legislature, member of Congress from 1833 to 1837, afterwards mayor of Charleston and collector of the port. He upheld the extreme States rights view. He published a biography of his brother-in-law, Robert Y. Hayne, and of Jonathan Maxey and Andrew Jackson.

PINCKNEY, CHARLES COTESWORTH (1746-1825), was the most distinguished member of a family noted in South Carolina history. Thomas Pinckney, its founder, emigrated from Lincolnshire, England, in 1687. Charles C. Pinckney was born at Charleston, Feb. 25, 1746. His father, who was chief-justice of the colony, took his family to England in 1753 to be educated. Charles graduated at Christ Church College, Oxford, studied law at the Middle Temple and attended the Royal Military Academy in France. After his return to Charleston, in 1769, he was a lawyer, and took part in the political agitation of the time. He was elected to the Provincial Congress, and at the outbreak of the war was made colonel. He assisted in the defence of Charleston in 1775, and afterwards went

North where he fought at Brandywine and Germantown. Returning to the South he had a share in the vicissitudes of the struggle for independence, and after the surrender of Charleston was prisoner, though part of the time on parole, until February, 1782. He was a delegate to the Convention which framed the U. S. Constitution, to the State Convention which ratified it, and to the State Constitutional Convention of 1790. He declined a seat in the U. S. Supreme Court and a position in Washington's cabinet. He was sent as U. S. Minister to France in 1796, but the Directory, offended at the attitude of America, dismissed him and threatened war. The government re-appointed him, but in a spirit of conciliation joined with him John Marshall and Elbridge Gerry. After various delays they were told by Talleyrand that no peace could be made until the members of the Directory had been paid. The insulting proposal was rejected, and according to a popular story, Pinckney exclaimed, "War be it, then! Millions for defence, but not a cent for tribute!" On the envoys' return to America this exclamation became a favorite motto. Pinckney was elected to Congress, and in 1800 he was supported by the Federalists for the vice-presidency, but was defeated. He had even less success in 1804, when he was a candidate for the presidency, and received only 14 out of 176 electoral votes.

His brother, **THOMAS PINCKNEY** (1750-1828), was also educated in England, and became a lawyer. In the Revolutionary war he rose to the rank of major, fought at Stono Ferry, and was wounded and captured at the battle of Camden, where he was serving as aide to Gen. Gates. He was sent as U. S. Minister to England in 1792, and in 1794 negotiated a treaty with Spain, securing to American citizens the free navigation of the Mississippi. Returning home in 1796 he was twice elected to Congress as a Federalist, and on the triumph of the opposite party retired to private life. In 1812 Pres. Madison appointed him major-general, and he took part in campaigns against the Creeks, whom he defeated at Horse-shoe Bend. He died at Charleston, Nov. 2, 1828.

PINE. This well-known class of trees has been already treated under *CONIFERÆ*, *FORESTRY*, and *LUMBER*, and little remains to be said concerning it. It may be stated generally that the pines are distinguished from all the other *Conifera* by the character of their foliage, which consists of needle-shaped leaves in clusters of 2, 3, or 5, surrounded by a sheath at the base. They embrace the pitch pines and their relatives, with leaves 2 or 3 in cluster, scaly-sheathed at base; wood resinous; cones lateral and persistent long after shedding the seeds, scales thickened at the ends, and often tipped with spines; leaves rigid; and the white pines, with softer leaves, 5 in cluster, the sheath early deciduous; cones long, cylindrical, terminal, and falling after the seeds are shed; scales little or not at all thickened at point; seeds thin-shelled and winged.

In the genus *Pinus* the flowers are monœcious, the fertile catkins terminal, solitary or aggregated, the sterile catkins clustered at the base of the shoot of the season. Each stamen answers to a flower, which is reduced to a two-celled anther with hardly any filament. The fruit is a woody cone, usually large, whose nut-like seeds are partly sunk in excavations at the base of the scales, there being two to each scale. There are from 3 to 12 cotyledons. The blossoms develop in late spring and the cones mature in the autumn of the second year.

The pines are confined to Europe, Asia, and America, except one species in the Canary Islands, and are found mostly in the temperate and cooler regions, where they form large forests. They are among the most useful of trees, yielding, besides wood, such important products as turpentine, rosin, tar, pitch, etc., while several species bear large and edible nuts. They

are well represented in the United States, whose white pine (*P. strobus*) is the most valuable commercially of all the pines, and yields most of the timber used in and exported from that country. In the northern and eastern regions of the United States this species formerly covered enormous tracts of land, but its range has been greatly reduced by the destructive axe of the woodman. In form the white pine is the most elegant of all the usually grown species, and it is much used for ornamental purposes. It is distinguished by its gray bark, which is smooth and shining up to 15 years of age, but afterwards cracks and roughens, the graceful



White Pine.

lightness of its branches, and its general gracefulness of form. It grows straight and rapidly, sometimes attaining a height of 200 feet. The wood is soft, fine-grained, and very durable, while the stem is so straight and even that large trunks are much sought for as masts of ships.

The United States have several other species of the 5-leaved, or white pine group. In the Pacific region is *P. Lambertiana*, or the great sugar pine of California and Oregon, one of the huge trees of the West, isolated specimens of which sometimes reach a height of 300 feet, and 20 feet diameter of trunk. It bears large, bright-green leaves, and cones of enormous size. Other western species of this group are *P. aristata*, the awn-coned pine; *P. flexilis*; and *P. monticola*, the mountain pine, whose wood resembles that of *P. strobus*.

Of pines with 3 leaves in the cluster, the Atlantic United States possess *P. australis*, the long-leaved or southern yellow pine, a lofty tree with very resinous wood and durable timber, much used in the South; *P. taeda*; *P. rigida*, the Northern pitch pine; and *P. serotina*, the pond pine. In the Pacific region there are of this group *P. macrocarpa*, the great hooked pine; *P. Subiniana*, Sabine's pine, which, like the above, bears large edible seeds; *P. ponderosa*, the most abundant pine of California and Oregon; *P. edulis*, the New Mexican nut pine, with large, edible seeds; *P. Coulteri*, a Californian species, with very large seeds, and leaves thicker and heavier than in any other species; and *P. insignis*, so named from its bright grass-green color.

Of pines with two leaves in the cluster may be named *P. pungens*, the Table Mountain, or prickly-

pine of the Southern Alleghenies; *P. mitis*, the yellow pine of the North, a valuable timber-tree; *P. inops*, the Jersey, or scrub-pine, a very resinous species; *P. banksiana*, the Northern scrub-pine; and *P. resinosa*, the resinous, or red pine of the North, which is next to the white pine in commercial value. There are other American species, several of which have been introduced from Europe as ornamental trees. Principal among the latter are *P. excelsa*, the Bhotan pine from the Himalayas; *P. cembra*, from the Alps; *P. sylvestris*, the Scotch pine, and *P. austriaca*, the Austrian pine. American pines have also been taken to Europe as ornamental trees, a purpose to which this genus of trees is excellently adapted through its graceful forms and evergreen foliage. For the same reason much has been done to disseminate the more attractive species over the earth.

The pines of the Southern Atlantic States are of special value in their abundant yield of rosin and oil of turpentine, tar, and pitch. This is mainly gathered from one species, *P. australis*, though *P. taeda*, the loblolly-pine, yields also a considerable quantity of turpentine. *P. australis*, the Southern yellow, or long-leaved pine, is a tree from 60 to 70 feet high and 15 to 20 inches diameter. Its leaves are bright green, and from 10 to 15 inches long, enclosed at base in long white sheaths. The hardness and compactness of its timber render it of great value for floors, or stairways where the wear is great, while it yields the great sum of the tar, rosin, and turpentine of the United States. The range of States from North Carolina to Florida possesses about 60,000 square miles of pine-forest, and their present yield of the above-named products is susceptible of great increase. The value of the naval stores (pitch, rosin, turpentine, etc.) produced in North Carolina in 1880 was about \$8,000,000, while South Carolina also yielded largely. This product is steadily on the increase, and promises to become of great value in the future. The crude turpentine is obtained by tapping the trees and collecting their exudations. From 10 to 25 per cent. of this is oil of turpentine, which is obtained by distillation, while the residuum constitutes the rosin. Tar is obtained by burning the dead limbs and wood in kilns, while the reduction of the tar to half its volume by evaporation yields pitch.

(c. M.)

PINEAPPLE, the fruit of *Ananassa sativa*, a tropical plant which is indigenous to See Vol. XIX. South America and some of the West p. 106 (p. 114 Am. Rep.). India islands, though now so perfectly naturalized in many tropical countries as to seem a native species. It is found in almost a wild state in India and Ceylon, and is abundant in the Malayan Peninsula, China, the islands of the Eastern

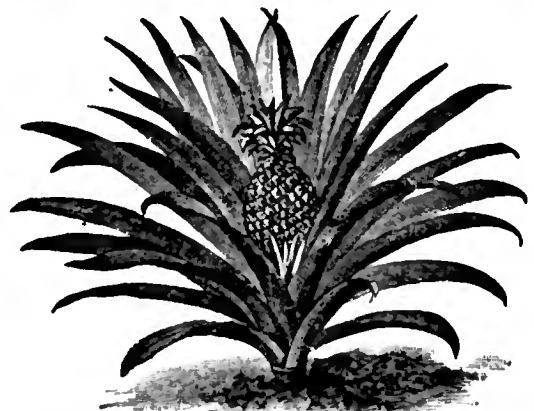

Pineapple.

Archipelago, and in parts of Africa. The fruit receives its name from its resemblance in form and external appearance to the cones of some species of pines

The plant is a member of the *Bromeliaceae*, a small endogenous family, nearly related to the ginger and banana families, its plants generally stemless, and mostly epiphytes in the forests of tropical America. The *Tillandsia*, or "long moss," of the Southern States, is a member of the family.

The pineapple plant is a biennial, with the habits of the aloe, but much thinner leaves, which form a crown of foliage, each leaf being recurved at the point and having small sharp spines on its edges. From the centre of the cluster of foliage rises a stem two or three feet high, bearing on its apex a conical spike of flowers, each flower in the axil of a bract. The upper flowerless bracts develop into a cluster of small leaves. The flowers have three outer or calyx divisions and three inner much longer petalous divisions, six stamens, and three styles. The pineapple is not a fruit botanically considered, but an aggregation of accessory parts, to which the fruit proper (the ripened ovary) bears but a small proportion. Seeds are rarely produced by the cultivated plant, but the whole cluster of flowers undergoes a remarkable change, all parts—stem, ovaries, bracts, etc.—becoming enormously enlarged, and when quite ripe fleshy and succulent, with a sweet and highly flavored juice. On the outer tessellated surface the tips of the bracts and the points of the petals show themselves.

There are many varieties of the pineapple, and when properly cultivated it is one of the best of fruits, but is too often tough, coarse, and indigestible. The first specimens seen in England were sent there as a present to Cromwell, and the plant was first cultivated there about 1715. It had been grown in Holland in the previous century. These glass-raised English pineapples are much superior in flavor to the ordinary commercial fruit, and still find a market, though sold from three to six shillings a pound, while the imported ones can be had for a much lower price. The fruit imported to American ports is better than that sent to England, on account of the shortness of the voyage, yet even here the glass-raised fruit is the best. The Bahamas have long been the source of much of the imported fruit, it being extensively grown there. At Nassau, New Providence, large quantities are canned for exportation. The culture of the fruit for exportation, which was at first restricted to the Bahamas, has extended to Jamaica, Trinidad, the Azores, and other islands, and the trade in it has become extensive and important. In addition to the fruit imported fresh and canned, the juice is expressed and sealed in bottles, for use in flavoring ices and as a syrup for soda-water. It will keep its flavor for a year. The leaves of this and allied species yield a long, fine, and very strong fibre, which is used in Manilla for weaving the beautiful Pina muslin, said to be the finest web in the world. It is exceedingly light, delicate, and durable, and is chiefly employed for ladies' handkerchiefs and dresses. Only small quantities of it are exported. (C. M.)

PINKNEY, WILLIAM (1764-1822), statesman, was born at Annapolis, Md., March 17, 1764. His father, a native of England and related to the Pinkneys of South Carolina, opposed the movement for American independence. The son studied law with Judge Samuel Chase and was admitted to the bar in 1786. He was a member of the State Convention which ratified the Federal Constitution in 1788, and he was elected to Congress in 1790, but did not take his seat, though he defended the legality of his election, which was questioned on the ground that he did not reside in the district whence he was chosen. By his eloquence and learning he rose to the head of the Maryland bar, and was prominent in State legislation. In 1796 he was sent to London as one of the commissioners under Jay's treaty, and during his eight years' stay recovered for Maryland from the Bank of England a claim of \$800,000. In 1806 Pres. Jefferson appointed him U. S. Minister to England, and after his return in 1811 Madison made him U. S. Attorney-General. In

the British attack on Washington Pinkney was wounded at Bladensburg, while commanding a battalion of volunteers. After the war he served one term in Congress and then went to Naples as special envoy and thence to Russia as minister resident. Returning in 1818 he was U. S. Senator from 1820 until his death at Annapolis, Feb. 25, 1822. His *Life* has been written by H. Wheaton (1825) and by his nephew, Bishop Pinkney (1853).

PINS. The original pin was undoubtedly a thorn, which was used to fasten together the rude clothing of our remote ancestors. Afterwards a considerable variety of materials came into use for this purpose.

In early England wooden skewers were used, while clasps and ribbons also did the duty of pins. The metal pin was introduced from France in 1543, the manufacture in England beginning in 1626. At Birmingham, which has long been the centre of the English pin manufacture, the industry began about the middle of the last century. Pins were long made there by hand labor, it being given as a remarkable evidence of the division of labor that it took 14 persons to make a pin. Now it takes but 2 or 3 to perform the same work, while the making of a needle, a much more complex process, requires about 70 persons.

Pin-making machines are American inventions of which many have been made during the present century. The first of these of importance was devised by Mr. Wright, a native of New Hampshire, who took out a patent in England in 1824. This machine was adapted to produce a complete pin at every revolution of a wheel. It at first worked imperfectly, and was rendered available only by long-continued experiment and at great expense. Its method of operation in its perfected state is briefly as follows: A pin is a piece of polished brass wire, with point and head, and covered with a coating of tin. In Wright's machine the wire is drawn from a wheel by pincers, which push forward the proper length for a pin at each rotation of the shaft. This is cut off by a die and carried forward to the pointing apparatus, where it is held while a revolving bevel-edge file-wheel roughly points it. It is then carried to a finer file-wheel which finishes the pointing. A third carrier takes the pin to the first heading die, where a steel punch thickens up the wire for the head, while a fourth carrier takes it to a second die, where the head is finished. The complication of this process is now reduced by one machine being used for pointing and another for heading. It only remains to whiten and stick the pins. The former is done in a copper vessel, where the pins are boiled in water containing tin. Several very efficient machines are in use for sticking the pins in paper.

The manufacture of pins in America was begun in 1810 by some English pin-makers. It was abandoned after the war, but practised for a short time again about 1820. A patent for the manufacture of pins at one process was taken out in 1816, but the machine proved too intricate. Somewhat later a small machine is said to have been in operation which made 30 solid-headed pins per minute. In 1832 a machine was invented by John J. Howe which produced from 40 to 50 pins per minute. In this machine the head was not solid, but was made from a coil of fine wire which was wrapped round the pin wire and pressed fast by dies. These "spun-head" pins had the defect that the head often came loose, and the Howe machine was soon adapted to make solid-headed pins which were first made in 1838, and soon superseded the spun-head pins. There have been other inventions, but those named are the most important. Pins are now made with astonishing rapidity, and fastened in papers by machines which seem almost magical in their operation. In one process the pins as made by the machine are placed in a feeding dish, from which they fall to a trough with a slit just wide enough to let the shank

through. The pins, thus suspended in rows by their heads, are carried to a sliding frame with a dozen grooves, in each of which a pin is deposited as it passes under the slit. A dozen are thus arranged in a row with their points all in one direction. The sheet of paper to receive the pins is passed through a grooving machine, which creases it into cross ridges, through which a row of a dozen pins is driven at every thrust forward of the carrying frame. This process can be repeated with great rapidity and the pins stuck as fast as made.

The statistics of the American pin and needle manufacture in 1880 were as follows, as given in the census reports: Establishments, 40; capital invested, \$1,144,550; hands employed, 1077; wages paid, \$392,214; value of materials, \$591,013; value of products, \$1,378,023. The making of pins and needles is, in great measure, confined to Connecticut, which State claims \$801,985 of the total annual product. (C. M.)

PINTO, SERPA. See **SERPA PINTO.**

PIPE LINES. See **PETROLEUM PIPE-LINES.**

PIQUA, a city of Miami co., Ohio, is on the W. bank of the Miami river, 28 miles N. of Dayton, on the Cincinnati, St. Louis, and Pacific and the Cincinnati, Hamilton, and Dayton Railroads. It has an opera-house, 3 hotels, 2 national banks, 2 daily and 4 weekly newspapers, 13 churches, and 5 schools. It has two foundries, oil-refineries, and manufactures of mattresses, straw boards, furniture, flour and meal. The city is regularly laid out with wide streets, lighted with gas and electricity. The site is a level plateau. Two bridges connect it with the opposite side of the river.

PISCICULTURE. See **FISH CULTURE.**

PISTOL. See **SMALL-ARMS.**

PITMAN, ISAAC, the inventor of phonography, was born at Trowbridge, England, Jan. 4, 1813. He was educated at a normal school in London and became a teacher at Barton-on-Umber in 1832, and afterwards at Wotton-under-Edge. Having published a book on shorthand, he removed to Bath in 1839 and devoted himself to the propagation of his system. He established a special printing-office called the Phonetic Institute, and issued a weekly paper. From time to time he revised his system, though its principles remained the same. See **SHORTHAND**, in **ENCYCLOPÆDIA BRITANNICA.**

His brother, **BENN PITMAN**, removed to the United States, and, settling at Cincinnati, carried on similar work. He was also engaged in reporting important trials.

PITRA, JEAN BAPTISTE, French cardinal, was born near Autun, Aug. 31, 1812. He became a priest and taught rhetoric in the seminary of his native town. Afterwards he entered the Benedictine order and resided in the abbey of Solesme. In 1858 Pope Pius IX. sent him to Russia to study the Oriental canons and liturgy, and in 1869 made him librarian of the Vatican. In 1863 Pitra was made cardinal and in 1879 promoted to the rank of cardinal-bishop of Frascati. In 1884 he was transferred to the see of Porto et Santa Rufina. He has published some biographies and a valuable collection of documents, called *Spicilegium Solesmense* (5 vols., 1852-60), which sheds much light on ecclesiastical history; *Juris ecclesiastici Græcorum historia et monumenta* (1864); *Hymnographie de l'Eglise grecque* (1867); and *Triodion Kataktaicon* (1879), which is a continuation of his work on the Greek churches. The *Spicilegium* has also been continued in a second series called *Analecta Sacra* and a third called *Analecta Novissima*.

PITTSBURG, the second largest city of Pennsylvania, is at the confluence of the Allegheny and Monongahela Rivers, which here form the Ohio. It is 353 miles west of Philadelphia by the Pennsylvania Railroad. Altogether, twelve railroads, six of which are trunk-lines, enter Pittsburg and contribute to its prosperity. The commerce, which was formerly

conducted on the Ohio River, has now been mostly transferred to the railroads, yet in 1887 there were 152 vessels belonging to this port, with a tonnage of 33,240. They were chiefly engaged in coal-carrying, the total capital invested being \$8,000,000. Pittsburg is subdivided into three districts, the Old City, East End, and South Side, formerly Birmingham. The Health Bureau estimated its population in 1888 at 237,000, while Allegheny has a population of 96,000. The latter is enclosed between the Ohio and Allegheny Rivers and is a favorite place of residence. The total population of Allegheny county in 1880 was 355,869, and is now estimated at 530,000. The appearance of the city has greatly improved since the introduction of natural gas in 1884 has removed the smoky pall which formerly hung over them. The **ENCYCLOPÆDIA BRITANNICA** gives an excellent account of the history, buildings, and industries of Pittsburg, yet the following particulars may be added. The finest public building is the new county court-house, built of granite and iron, 208 by 306 ft., and enclosing a court-yard. It is 3 stories high and has a tower 425 ft. high. It replaces one that was destroyed by fire in May, 1882. It was completed and furnished at less than the estimated cost, \$2,500,000, and was dedicated with special ceremonies on Sept. 24, 1888, when the centennial anniversary of Allegheny county was celebrated with civic and military parades. The U. S. government building, which furnishes accommodation for the post-office and national courts, was built in 1884. The municipal hall is a stone structure with a tower 175 ft. high. A fine Exposition building, with valuable contents, was destroyed by fire, but a new one has been commenced at the apex of the triangle occupied by the city, and will be completed in 1889.

Pittsburg has 26 national banks, with a capital of \$10,620,000; 5 private banks, capital \$700,000; 7 State banks, capital \$1,815,300; 14 savings banks, \$11,964,850. There are 19 blast furnaces in Pittsburg besides 5 in the vicinity, 36 iron- and 20 steel-mills. The capacity of the iron-mills is 780,000 tons yearly, and their actual output is about 580,000. The output of rails in 1887 was 360,000 tons; of iron pipes, 320,000 tons; of railway supplies, 132,000 tons; of crucible steel, about 42,000 tons; of Bessemer steel, 360,000 tons. Glass is largely manufactured in Pittsburg and the use of natural gas has increased the amount. There are 15 factories making window-glass, 9 making bottles, 16 making table-ware, 4 making fancy ware, 7 making lamp-chimneys, and 1 making mold-ware. The capacity of the plate-glass manufacture is now 250,000 sq. ft. per month. There are also locomotive-works with a capacity of 200 yearly, manufactures of steam-engines, fire-proof safes, brass, copper, lead, bronze and tin works, manufactures of iron chains, nuts and bolts, shot-towers, tanneries, factories making Britannia ware, paper-bags, carbon-points, boots and shoes, white-lead, etc. Pittsburg has the largest cork-factory in the world. The lumber trade in 1887 amounted to 2,000,000 ft., and the pork-packing to 108,000,000 pounds.

During the civil war 164 companies of soldiers were raised for the Union army in Allegheny county and 30 more were recruited from it. The official records of Pennsylvania give it credit for 23,000 soldiers, of whom 4000 perished in the struggle. The Subsistence Committee, a voluntary association organized in July, 1861, gave meals to 409,745 soldiers passing through Pittsburg, and relieved 79,460 sick and wounded at the Soldiers' Home. The Sanitary Fair held in June, 1864, realized \$361,516, part of which was used in endowing the Western Pennsylvania Hospital, and the rest for the aid of the soldiers. In July, 1877, a strike took place among the employés of the railroads passing through Pittsburg. The weakness and inefficiency of the mayor allowed a riotous mob to seize and destroy railroad property there to the value of more than \$2,500,000. The

See Vol. XIX. p. 150 (p. 160 Am. Rep.)

State militia was called out and suppressed the riot. Allegheny county was subsequently held responsible for the damage done to property, and an attempt to transfer the burden to the State was defeated.

PITTSFIELD, a city of Massachusetts, shire-town of Berkshire county, is on a beautiful plateau, 1200 ft. above the sea. It is on the Boston and Albany and two other railroads. There are six lakes around it which give rise to the Housatonic River. The city has a marble court-house, 3 banks, several hotels, an atheneum with free library, 13 churches, some of which are notable for architecture, a high-school, 30 public schools, a young ladies' school, 2 weekly newspapers, and 2 parks. The lakes furnish water-power which is used in the manufacture of cotton and woollen goods, knit goods, silk, and tacks. The site of Pittsfield was granted to Boston in 1735, and was hence known as "Boston Plantation" until 1761, when it was incorporated under its present name. Its population in 1880 was 13,364.

PITTSSTON, a borough of Luzerne co., Pa., is on the E. bank of the Susquehanna River, 9 miles above Wilkesbarre, and in the centre of the Wyoming coal-region. It is on the Lehigh Valley, the Erie and Wyoming Valley, and the Delaware, Lackawanna, and Western Railroads. The last-named road crosses the Susquehanna River here by a bridge, and there are two other bridges connecting the borough with West Pittston, a village of nearly 4000 inhabitants, which is chiefly used as a place of residence. Pittston itself is a mining town, though there are also several manufacturing industries, including 3 knitting-mills, a silk-mill, and foundries producing stoves, car-wheels, engines, and iron-roofing. It has 3 hotels, a national bank, and 2 other banks, 1 weekly and 2 daily newspapers, 18 churches, and 8 graded schools. It has a park and water-works, and is lighted with both gas and electric light. The assessed valuation of its property is \$725,922, but the actual value is over \$1,000,000. The public debt is \$35,000, and the yearly expenses are \$11,000. The first house on the site was built by Zebulon Marcy in 1770. The borough was incorporated in 1852. The population is largely of foreign birth and in 1880 amounted to 7472.

PLAINFIELD, a city of New Jersey, in Union co., is on Green Brook, 24 miles W. S. W. of New York city, by the N. J. Central Railroad. It has 2 national banks, 14 churches, good public and private schools, and 2 weekly newspapers. The manufactures are of hats, clothing, and machinery. Plainfield was laid out in 1735 and made a city in 1869. It has become a favorite place of residence for persons doing business in New York. Its population in 1880 was 8125.

PLANE, a tree of the genus *Platanus*, order *Platanaceae*, well known under the common names of buttonwood and sycamore, the latter a misnomer, as the real sycamore is a very different tree. The order contains but one genus, *Platanus*, and three species, two of which are natives of the United States. It is classed by some writers with the bread-fruit family, which it resembles in many particulars. The planes are distinguished by their broad leaves, globular inflorescence and fruit, and watery juice. The leaves are 5 to 6 inches long, and 7 to 8 broad, with 5 lobes and long foot-stalks. The leaf-buds end in the leaf-stalk, and by their expansion break the articulation of the previous leaves, so that the plant is necessarily deciduous. The young shoots, leaves, and stipules are thickly covered with a fine down, which falls off as they expand and floats in the air. When breathed in it is apt to produce a disagreeable and persistent cough, for which reason it is objectionable to plant these trees too near to dwellings. The female catkin of the plane is a globular ball, less than an inch in diameter, borne on a flexible, downy footstock from 2 to 5 inches long. The flowers are so small as to be imperceptible. The male catkins are globes of about $\frac{1}{4}$ inch in diameter, borne on slender, thread-like stalks of an inch or two

in length. The stamens are very numerous, each of two cells opening at the sides and filled with white pollen. They are surmounted by brownish-green glandular disks which form the surface of the ball. The ripened seeds are small and light, yet have the structure of nuts. They remain on the tree until the ensuing spring, when they are dispersed by the bristly down attached to them. A marked feature of the planes is the character of their bark, which is deficient in toughness and extrusibility, while its layers have little mutual adhesion. In consequence the outer layers are apt to crack and scale off in large irregular patches, revealing the whitish inner bark. This peculiarity gives the plane a different appearance from any other tree. The planes are large, spreading trees, and have long been highly esteemed as shade-trees.

The Oriental plane (*Platanus orientalis*), a native of the Levant, is a tree of great size, growing to the height of 80 feet and sometimes higher, and occasionally of immense diameter, while its thickly leaved branches spread widely from the trunk. It was a favorite tree in ancient times, the Romans particularly valuing it as a shade-tree. It is still much esteemed in the East, and is a great favorite in Persia. Its wood, which has a beautiful surface, and takes a brilliant polish, is much used in carpentry, joining, cabinet-making, and even in ship-building.

The occidental plane (*P. occidentalis*), the buttonwood of the eastern United States, is the largest and loftiest of American deciduous trees. It has a massive column or trunk, tapering rapidly to some distance from the ground, and then ascending with a very slight taper. Specimens have been measured on the banks of our western rivers of from 40 to 50 feet diameter and 100 feet high, but such dimensions as these are very seldom attained. The tree is a very rapid grower, especially near water, and sends its lower limbs out horizontally, while the density of its foliage makes it an excellent shade-tree. The leaves are less palmated than those of the oriental plane, are large in size and seldom injured by insects, while they cluster so thickly as to throw a very dense shade. The wood is of little use in the arts, being perishable if exposed to the weather, and liable to warp, but it makes good fuel when grown on dry soil. The bark of the plane has some astringency, and the leaves have been used in fomentations. They were formerly considered an antidote to the poison of serpents. The American plane has a wide distribution, extending from the Atlantic to the States west of the Mississippi and as far north as Montreal, where it is called the cotton tree.

A third species occurs on the Pacific coast, the California plane (*P. racemosus*). It is a well-distinguished species, its leaves being deeply cleft, and very downy when young, while their under surface continues covered with a white woolly down, that gives them the feeling of thick woollen cloth. The male catkins are smaller than peas. The female catkins grow in racemes with from 3 to 5 pendent balls, the styles being remarkably long and persistent on the ripe balls. The tree has a very unusual appearance with its long pendular racemes, nine inches long, each with from 3 to 5 balls. The wood is superior to that of *P. occidentalis*.

(C. M.)

PLATTSBURG, a city of New York, seat of Clinton co., is on the W. shore of Lake Champlain at the mouth of the Saranac River, and on the railroad of the Delaware and Hudson Canal Company, 63 miles S. of Montreal. Two fine iron bridges cross the river. The Chateaugay and the Au Sable Railroads lead into the Adirondack region. In the summer a steamboat runs daily to Fort Ticonderoga, 70 miles south, and others run to Burlington, Vt., and various points of interest on the lake. Plattsburg has 5 hotels, 4 national banks, 1 daily and 4 weekly newspapers, 7 churches, a high-school, and six other schools. Its industries comprise an iron-furnace, machine-shops, sewing-machine-works, wagon-factory, and planing-mills. It has water-

works and 2 small parks, and is lighted with gas and electric light. Lumber, iron, and grain are shipped here. In 1880 the population of the village was 5245 and of the township 8283. On Sept. 11, 1814, General A. Macomb here repulsed a superior British force, while on the adjacent Cumberland Bay Commodore McDonough gained a complete victory over the British fleet at the same time.

PLAYFAIR, SIR LYON, a British chemist and publicist, was born at Meerut, Bengal, May 21, 1819. He was educated at St. Andrews, Scotland, and studied chemistry under Prof. Thomas Graham at Glasgow and afterwards at London. In 1838 he went to Giesesen to study organic chemistry under Liebig, some of whose works he translated into English. On his return he had charge of calico-print-works at Clitheroe and in 1843 he was made professor of chemistry in the Royal Institution at Manchester. He was employed by the government in various commissions and especially in connection with the World's Fair of 1851. For his services he was made a C. B., and in 1853 was made joint-secretary with Henry Cole, of the newly established department of Science and Art. In 1856 he was appointed inspector-general of the Government museums and schools of science. In 1858 he was called to the chair of chemistry in the University of Edinburgh, and in 1868 was elected to Parliament for the Universities of Edinburgh and St. Andrews. In 1873-74 he served in Mr. Gladstone's cabinet, being postmaster-general and member of the privy council. He was president of the commission which in 1874 presented the plan for the reorganization of the civil service. After the election of 1880 he was made deputy speaker of the House of Commons and chairman of ways and means. On retiring in 1883 he was made K. C. B. Besides his technical work Dr. Playfair has published several lectures on educational and sanitary matters.

PLEASANTON, ALFRED, general, was born at Washington, D. C., June 7, 1824. He graduated at West Point in 1844 and entered the dragoons. He fought in the Mexican war under Gen. Taylor and was brevetted for gallantry. He afterwards served on frontier duty and as assistant adjutant-general. He conducted his regiment from Utah to Washington on the outbreak of the civil war. He served creditably in McClellan's Peninsular campaign and was made brigadier-general of volunteers in July, 1862. When Lee's army invaded Maryland Pleasanton commanded the division of cavalry which followed them, and was engaged at Antietam. By his bravery and skilful management at Chancellorsville (*q. v.*) he checked "Stonewall" Jackson's attack. Being promoted major-general in June, he had chief command of the cavalry at Gettysburg (*q. v.*) In 1864 he was transferred to Missouri, and freed that State from the invasion of Gen. Sterling Price. In March, 1865, he was brevetted major-general U. S. A. In 1866 Gen. Pleasanton was mustered out of the volunteer service and in 1868 he resigned also from the regular army, believing that his claims to promotion had been slighted. He was U. S. collector of internal revenue for some years and afterwards president of the Terre Haute and Cincinnati Railroad. In May, 1888, he was placed on the retired list of the army with the rank of colonel.

PLOUGH. See AGRICULTURE, Chap. III. (1).

PLUM, the name given to *Prunus domestica*, a tree of the order *Rosacea*, which differs from the cherry chiefly in having a larger and richer fruit, which ripens later in the season. Prof. Gray says that the distinction between the plum and the cherry, while very perceptible, is hard to define botanically, none of the botanical distinctions being constant. The common plum is supposed to have originated from the bullace, *P. insubrica*, a native of Europe, with a black fruit covered with a yellow bloom, and from *P. spinosa*, the sloe, a thorny shrub, commonly called

blackthorn from its black bark. Its fruit is a globose black drupe, covered with a fine blue bloom when ripe. The plum is said to be a native of Southern Russia, the Caucasus, and the Volga region.

The domestic plum resembles the sloe, though larger and destitute of spines. It is from twelve to twenty feet high, with dark green, lanceolate leaves and solitary flowers of white color, having twenty to thirty stamens with orange anthers, and one and sometimes two styles. The fruit is covered with a fine bloom, and contains a smooth surfaced stone, sharp pointed at the ends and with a longitudinal furrow passing around it. There are very numerous varieties, which differ greatly in size and flavor, some being two inches long, while others are less than an inch. Among the varieties the greengage is the most esteemed for sweetness and flavor. It is a delicious dessert fruit, while some of the inferior varieties are very sour and harsh in taste. The Damson, another well-known variety, probably received its name from Damascus, which was formerly celebrated for its plums. The plum is a very hardy plant, and is cultivated throughout Europe, from Norway to Barbary, and widely in the United States, in which country many choice varieties have originated, some of them of great size and beauty of fruit. It is less grown here than formerly, however, on account of the ravages of the curculio and of other diseases. Another species of the same genus, the apricot (*P. Armeniaca*), is widely raised in Europe, but is only occasionally cultivated in the United States. It is a native of Armenia, growing from fifteen to thirty feet high, and bearing a fruit which resembles the peach, of roundish shape and yellow color, ruddy on the side next the sun, the flesh being yellow and juicy.

The sloe and bullace are both naturalized in the United States, and there are four native species of *Prunus* known here. *P. Chickasa*, the Chickasaw plum, is a shrub or small tree of the Southern States, which bears a thin-skinned, yellowish-red fruit of agreeable flavor. *P. Americana*, the wild yellow or red plum, is a bushy tree eight to twenty feet high, bearing a roundish, oval fruit of two-thirds inch diameter, with a tough skin, but pleasant-flavored pulp. It has a wide range from Canada to Georgia, and has been cultivated. The beach plum, *P. maritima*, is a low, straggling shrub, which is found on sandy coasts from Massachusetts to New Jersey, one variety reaching to Alabama. Its fruit is often an inch in diameter, and of pleasant taste, but somewhat astringent. *P. glandulosa*, of Texas, is less than a foot high, with very crooked, thorny branches.

The finer varieties of the plum form choice table-fruit, while the inferior kinds are used in pies, conserves, and sweetmeats. In moderate quantity plums are wholesome, but are apt to produce colic and diarrhoea if eaten to excess, particularly if not fully ripe. A pleasant wine is made from them in Europe, and in some places a strong spirit is distilled from the fermented juice. The dried plum, under the name of prune, is a favorite dessert article, and great quantities are thus prepared in Europe. Many of the inferior grades are sun-dried, the better qualities carefully heat-dried. The best prunes come from France, while large quantities are produced in Spain and Turkey, and many of a coarse quality in Germany. The prunellos, the finest grade of prunes, are made from the greengage and the St. Catharine plum. These afford a delicious and highly esteemed table-fruit.

(C. M.)

PLUMBAGO.—The mineral known under the two names of Plumbago and Graphite, and See Vol. XIX, p. 230 (p. 242 Am. Rep.), also frequently but incorrectly called Black Lead, is one of the several forms assumed by carbon, the others being diamond and coal. It occurs in considerable abundance in many parts of the world, being found in laminæ or masses in the granite, gneiss, mica, schist, and crystal-

fine limestone of the primary geological strata. Concerning its origin mineralogists are in ignorance, though it is generally believed that it was derived from very ancient vegetation, which has left no other trace of its existence. It is often found in coal veins where traversed by trap-rock, indicating that the coal has been transformed into plumbago by heat. It is also produced in iron furnaces, crystallized in flat flakes in the cavities of cast-iron. As found in the rocks it is composed of pure carbon, with a little iron oxide mechanically mixed, and occurs in foliated prismatic masses, and also in a compact granular form. It is infusible, very difficult of combustion, and of a lead-like metallic lustre, from which, and the readiness with which it leaves a black mark on paper, it has received its name of black lead.

Plumbago is utilized in several important methods, of which the best known is its employment in the manufacture of lead pencils. For this purpose it is used either in its pure state, or ground up and mixed with clay. For the finer grades of pencils plumbago free from impurities is required. This is attained by grinding and removing all impurities and then condensing by pressure, or by selecting pure natural graphite and cutting it into appropriate sizes. A second important use is in the manufacture of retorts and crucibles, to which its high resistance to heat well adapts it. For this purpose it is mixed with fire clay, thus forming one of the most refractory substances known. Plumbago crucibles are used largely in the manufacture of Bessemer steel. Another important use is that of dry lubrication, as in producing smoothness of action between the frictional surfaces of the piano and organ. Plumbago, thus applied, must be absolutely free from grit. Recently it has come into extended use as a general lubricant for machinery. Mixed in proper proportions with an oily substance it makes a perfect lubricant, which remarkably reduces friction, and is unaffected by heat or cold, steam or acids. Others of its uses are for pigments, and for polishing iron surfaces, while in foundries it is employed as a facing for moulds in order to produce a smooth surface in casting. In this particular it is of great utility. As it is a good conductor of electricity, it is sometimes used to coat moulds in electrotyping.

Plumbago is found in many parts of the earth, but in few places in sufficient purity for profitable working, it being generally mixed in the vein with slaty and other impurities. Very pure plumbago was formerly extracted from the Borrowdale mines of England. This was of sufficient purity to be sawn directly into pencils, as is now done with that extracted from the Alibert mine of Siberia. The great source of the present supply of plumbago is the island of Ceylon, where a very pure quality is obtained. It is mined also in several European localities.

Plumbago is distributed widely throughout the United States and Canada, though in few places in sufficient purity for profitable working. It is found at intervals along the whole line of the Alleghenies, in California, and in several other localities, but in few places in sufficient purity to warrant its mining. The Eureka mine of Sonora, California, is said to be capable of yielding 1000 tons monthly. The only place where plumbago is now mined successfully in the United States is at Tieonderoga, Essex co., N. Y. Of this place we are told in the *Mining Resources of the United States*, 1883-84: "The vein there has been worked to a depth of 600 feet. The graphite schist or vein is about 15 feet thick, carrying from 8 to 15 per cent. of graphite, and is practically inexhaustible. This mine is unusually rich, for it perhaps produces the finest graphite in the world." It contains occasional pockets of graphite of the finest quality, consisting of 99.9 per cent. of carbon. This is the purest known, and is particularly well adapted for pencil-manufacture. (See PENCILS.) (C. M.)

PLUMBING. See SANITARY SCIENCE.

PLUMER, WILLIAM SWAN (1802-1880), clergyman and author, was born at Griersburg, Pa., July 25, 1802. He graduated at Washington College, Va., in 1825, studied theology at Princeton, and was ordained to the Presbyterian ministry in 1827. He served several churches in Virginia and North Carolina, and while at Richmond was editor of *The Watchman of the South* (1837-45). In 1838 he was moderator of the Presbyterian General Assembly. He was afterwards pastor in Baltimore, and in 1854 was called to a professorship in the Western Theological Seminary at Allegheny City, Pa. On account of his sympathy with the South in the civil war he was obliged to retire in 1862, when he removed to Philadelphia. In 1866 he became professor in the Theological Seminary at Columbia, S. C., and held that position until 1880, having in 1871 been moderator of the Southern Presbyterian General Assembly. He died at Baltimore, Oct. 22, 1880. In theology he was an extreme Calvinist. He published *The Law of God*, an exposition of the Ten Commandments (1864), *The Grace of Christ* (1853), *Vital Godliness* (1865), *Pastoral Theology*, *Studies in the Book of Psalms* (1866), *Commentaries on the Romans and the Hebrews* (1870), besides numerous tracts and minor works.

PLUMPTRE, EDWARD HAYES, English clergyman, was born in London, Aug. 6, 1821. He was educated at University College, Oxford, and on graduating in 1844 became fellow of Brasenose College. He was chaplain of King's College, London, from 1847 to 1868, being also professor of pastoral theology there from 1853 to 1863, and of exegesis from 1864 to 1881. He was also dean of Queen's College, London, from 1855 to 1875, when he was made its principal, but he resigned in 1877. He was chosen select preacher at Oxford in 1851, 1864, and 1872, and Boyle lecturer in 1866. In 1869 he was made rector of Pluckley, Kent, and in 1873 vicar of Bickley, which position he held till 1881, when he was made dean of Wells. He took part in the revision of the English Bible, and in 1875 the University of Glasgow conferred on him the degree of D. D. Besides contributing to *Smith's Bible Dictionary* he annotated the *Book of Proverbs* in the *Speaker's Commentary*, the first three *Gospels*, *Acts*, and *Second Corinthians* in Bishop Ellicott's *New Testament Commentary*, and *Isaiah* and *Jeremiah* in the *Old Testament Commentary*. He assisted also in the *Cambridge Bible* and other commentaries, edited the *Bible Educator* (1875) and published the *Biblical Studies* (1870) and *Introduction to the New Testament* (1883). He has also published *Epistles to the Seven Churches* (1877); *Movement of Religious Thought* (1879); *Things New and Old* (1884); *Spirits in Prison* (1884); and *Life of Bishop Thomas Kerr* (1886). Dean Plumtre is also favorably known by his poems and especially his excellent translations of *Sophocles* (1865) and *Æschylus* (1868), and of *Dante* (2 vols., 1887). His original poetical works are *Lazarus* (1864) and *Master and Scholar* (1866).

PLYMOUTH, the shire-town of Plymouth co., Mass., is situated on Plymouth Bay, part of Cape Cod Bay, 37 miles S. E. of Boston, at the terminus of a branch of the Old Colony Railroad. Here the Pilgrim Fathers landed on Dec. 21, 1620, and founded their first settlement in America. Plymouth village is at the north end of the "town," which is altogether about 16 miles long and 6 miles wide. The "town" contains large tracts of woodland and 180 ponds, of which 135 bear names and are well stocked with perch, pickerel, etc. The village contains Pilgrim Hall, in which memorials of the Pilgrims of the Mayflower are preserved. In front of it is a portion of the rock on which they first stepped. The rock itself is in Water street, and is now covered by a granite canopy. The village has also a town-hall, a court-house, 2 national banks, 2 savings banks, 2 weekly newspapers, 11 churches, a high-school, and 30 graded schools. Manufactures are extensively carried on, the chief prod-

ucts being cordage, nails, tacks, rivets, shoes, shoehawks, cotton, duck, and seamless pockets. There are also 2 zinc-rolling-mills and an iron-foundry. The village is modern in appearance, is lighted with gas, and has water-works, the cost of which, about \$100,000, constitutes its public debt. The property is valued at \$5,000,000 and the yearly expenses are about \$60,000. The town is much resorted to by summer visitors, there being 7 hotels, and 7 trains daily to and from Boston, besides daily trips by steamboat in the summer.

PLYMOUTH, a borough of Pennsylvania, in Luzerne co., on the east bank of the Susquehanna River, is on the Delaware, Lackawanna, and Western Railroad, 8 miles from Wilkesbarre. It is a coal mining town with 6665 population in 1880. It was in 1885 the scene of a serious epidemic of typhoid fever, which was eventually traced to the contamination of the water-supply by the excreta of a single family some months previous.

POEY Y ALOY, FELIPE, a Cuban naturalist, was born at Havana, May 26, 1799. Though his father was a Frenchman, he was educated at Havana, and in 1823 became a lawyer there. His inclination for natural history was so strong that in 1826 he went to Paris with drawings and specimens of Cuban fishes, which were submitted to Cuvier and Valenciennes. These eminent naturalists used his researches in their *Histoire Naturelle des Poissons*, giving him due credit. In 1833 Poey returned to Cuba and in 1842 he was appointed professor of comparative anatomy and zoology in the Royal University of Havana. Though hampered by want of means, Prof. Poey diligently prosecuted his researches in natural history. He made valuable contributions to the U. S. National Museum, to the Museum of Comparative Zoology at Cambridge, Mass., and to the Museum at Madrid. His chief contributions to science are *Memorias sobre la Historia Natural de la Isla de Cuba* (2 vols., 1855-60); *Synopsis Piscium Cubensium* (1868), which was revised under the title *Enumeratio Piscium Cubensium* (1875), but he has spent years in preparing a valuable *Ictiologia Cubana*, still in manuscript.

POINDEXTER, GEORGE (1779-1853), politician, was born in Louisa county, Va., in 1779. He began to practice law in his native State, but in 1802 removed to Mississippi Territory, where he was made attorney-general by Gov. Claiborne. In 1807 he was sent to Congress as Territorial delegate, and in 1813 he was appointed U. S. District Judge for Mississippi. When that State was admitted to the Union, in 1817, he was elected to Congress, and in 1819 he was elected governor. In 1831 he was sent to the U. S. Senate, and though he had formerly been a defender of Gen. Jackson, he now turned against him. Poin Dexter went to Kentucky in 1835, but afterwards returned to Mississippi, where he died at Jackson, Sept. 5, 1853.

POINSETT, JOEL ROBERTS (1779-1851), statesman, was born at Charleston, South Carolina, March 2, 1779. He was of Huguenot descent, was educated by Pres. Dwight at Greenfield, Conn., and afterwards studied medicine at the University of Edinburgh and military science at Woolwich. He spent some years in travel through Europe, visited the Calmuck Tartars and entered Persia. In 1809, being sent by Pres. Madison to examine the condition of the people of South America then in insurrection against the Spanish authorities, he established friendly relations with Buenos Ayres and then crossed the continent to Chili. While he was there the Spanish authorities seized several American whalships at Talcahuana, but Poinsett, with the aid of some Chilians, liberated the vessels. The British preventing his return by sea, he again crossed the Andes. After his return home he was elected to the Legislature and in 1821 to Congress. He also visited Mexico in 1822 to report upon the prospects of the empire established

by Iturbide. In 1825 he was sent as minister to that country and in spite of troubles due to revolutionary movements negotiated treaties with its government. He returned to Charleston in 1829 and became a leader of the Union party in the struggle against nullification. He was in constant correspondence with Pres. Jackson during this trying period and heartily approved the action of the national administration. After the nullification movement had failed Poinsett married and became a rice-planter. Pres. Van Buren called him from his retirement, in 1837, to be secretary of war. While holding this office he organized and equipped the Wilkes Exploring Expedition. He planned and founded the first National Museum at Washington. He reorganized the artillery service and strongly urged other improvements in army methods. Yet he stoutly resisted the movements leading to the Mexican war, which, however, in its course displayed effectively the value of his services to the military strength of the country. At the close of his term he retired again to his plantation at Statesburg, S. C., where he died Dec. 12, 1851. See Dr. C. J. Stille's "Life and Services of J. R. Poinsett" in *Penna. Magazine of History and Biography* (1888).

POISONS. The subject of toxicology has been very fully treated in the *ENCYCLOPEDIA BRITANNICA*, and this article (p. 275 (p. 287 Am. Rep.)) will be devoted to a brief statement of antidotes. An antidote is a substance which is used for the purpose of overcoming the deleterious effects of some poison upon the animal system. There are two kinds of antidotes—physiological and chemical. Physiological antidotes are uncertain in their action and require for their use a thorough knowledge of physiology and pathology. We shall not, therefore, discuss them in the present article.

Chemical antidotes act usually by forming with the poison a new compound which is inert so far as the human system is concerned. With but one exception they are incapable of acting when the poison has been absorbed. The exception is a very important one in that it is the antidote of a very common poison, carbolic acid. This antidote is a soluble sulphate, especially the sulphate of magnesium or Epsom salt, or the sulphate of sodium or Glauber's salt. It seems to have the power of forming a harmless sulphocarbonate in the blood as well as in the alimentary canal.

The antidotes are best studied for practical purposes under general heads.

All mineral and vegetable acids, with but one single exception, are neutralized and rendered innocuous by ordinary alkalis or alkaline earths. The exception is *oxalic acid*, whose salts of potassa and soda are as poisonous as is the acid itself. The antidote is lime, the oxalate of lime formed being completely insoluble and inert.

In applying an antidote to an acid time is of the utmost importance, and as soap is usually at hand, and is very effective, it is the most frequently employed of all the alkaline substances.

The alkalis are also more or less antidotal to most of the *mineral salts*, the principal exceptions being, 1. *Corrosive sublimate*. The yellow oxide of mercury, which is formed when an alkali is added to corrosive sublimate, although less poisonous than the corrosive sublimate, is very deleterious in its action upon the system. 2. *Tartar Emetic*. The oxide of antimony acts less promptly but scarcely less certainly than tartar emetic itself, and consequently we are not able to employ it in tartar emetic poisoning. Tannic acid, though not a perfect antidote, is still the best we have for the salts of antimony. 3. *Arsenic*. The antidote to arsenic and its soluble preparations is some form of the hydrated sesqui-oxide of iron. It is necessary that this antidote be freshly prepared, be given in a moist state and in great excess. If it has long been prepared it is nearly useless. It should, therefore, be made when wanted by precipitating the tincture of the

chloride of iron, the solution of the per sulphate of iron, dialyzed iron or some other soluble sesqui-compound of iron, by an alkali. Ammonia is frequently employed as the alkali, but in order to free the precipitate from it much washing is required, and as time is a matter of the greatest importance, it is therefore preferable to add to the iron solution magnesia in excess. The powder which falls after such treatment is a mixture of the hydrated sesqui-oxide of iron and magnesia, and is believed by many chemists to be superior to the hydrated sesqui-oxide of iron as an antidote to arsenic. It is the official *antidotum arsenici* of the Prussian Pharmacopœia and has been officially recognized in the last revision of the U. S. Pharmacopœia (*Ferri-Oxidum Hydratum cum Magnesia*, U. S. P., 1880). 4. *Nitrate of Silver*. It has for its antidote common salt, which is very much more effective than soap or the alkalis.

Alkaline Poisons have for their antidote vegetable or dilute mineral acids. When these are not to be had, or even if they be used, it is very well, in most cases, to administer bland oils, which act in part by forming a soap with the alkali, and in partly mechanical sheathing the stomach and bowels from the local action of the poison.

Of the *neutral or elementary poisons* one of the most important is phosphorus, whose antidote is not, as was formerly thought, freshly calcined magnesia or a fixed oil, but sulphate of copper. Very old European oil of turpentine is also antidotal and official, but American emulsions seem to have no such property.

Very few *vegetable poisons* have reliable chemical antidotes, but tannic acid forms with alkaloids salts which are not readily dissolved in the stomach and absorbed. Whenever a poison containing an alkaloid has been taken, tannic acid or nutgalls may be given, and follow immediately by an emetic and such a cathartic as castor oil, in order to remove the only partially inert tannate. Mustard flour is the most rapidly acting and easily attainable emetic in poisoning. A tablespoonful may be given at once in a tumblerful of water and repeated in fifteen minutes if required. The principal poisons depending for their activity upon an alkaloid are *opium*, *belladonna*, *hyoscyamus* or *henbane*, *stramonium* or "*Jimson weed*," *nux vomica*, *hemlock* or *conium*, *water hemlock*, *Calabar bean*, poisonous mushrooms, *veratrum viride*, *aconite*, *digitalis*, *Gelsemium* or *yellow jessamine*. *Strychnia* and *morphia* are alkaloids. (H. C. W.)

POLAR REGIONS. See ARCTIC EXPLORATIONS.

POLITICAL CONVENTIONS form the present customary method in the United States of nominating persons to be voted for at elections. These conventions are of various grades, State, city, county, and Congressional district, but all are conducted in practically the same way. The citizens of a political party are invited to meet at a primary election in their precinct, or division, to choose delegates to these conventions, who are in theory free to name candidates and to vote according to their own judgment on the names presented. In some cases, however, the people vote also directly for the candidate and the delegate is required simply to register the will of the majority of those who elected him. The dangers and difficulties attending this method and others which have been used are discussed under CAUCUS (*q. v.*) This article will give simply a brief outline of the various national conventions.

As early as September, 1812, a convention in which eleven States were represented was held in New York, and nominated DeWitt Clinton for the Presidency. Madison, then President, had already been nominated for a second term by a Congressional caucus. Both candidates and their respective followers belonged to the Republican party, but Madison, having the "regular" nomination, was elected. The system of nominating by Congressional caucus fell

to pieces in 1824, when only one-third of the Republican members of Congress attended the caucus which nominated William H. Crawford. Other candidates were presented in various ways, and, there being no choice by the people, the House of Representatives elected John Quincy Adams. Andrew Jackson, who had received a plurality of the electoral votes, was forthwith nominated by the Legislature of Tennessee as presidential candidate for the next election, and this action being approved by the Democratic party throughout the country, he was elected in 1828 over Pres. J. Q. Adams, who refused to use his power of patronage to assist his own election.

In September, 1830, a national conference of citizens opposed to Free Masonry (see ANTI-MASONRY) was held in Philadelphia. It had been called by the New York Anti-Masonic State Convention, and was presided over by Francis Granger of that State. It called a national nominating convention, which met in Baltimore, Sept. 26-28, 1831, and nominated William Wirt, of Maryland, for President, and Amos Ellmaker, of Pennsylvania, for Vice-President. The example of this first national political convention was followed by the "National Republican" convention which assembled in Baltimore, Dec. 12, 1831. James Barbour, of Virginia, presided; Henry Clay, of Kentucky, was unanimously nominated for President, and John Sergeant, of Pennsylvania, for Vice-President. The Democratic party also adopted this method in the following May and held a convention at Baltimore, at which Martin Van Buren was selected as candidate for Vice-President, a second term of Presidency having been already conceded to Jackson. (See DEMOCRATIC PARTY.)

In May, 1835, a national Democratic convention was held at Baltimore, 21 States being represented, and Andrew Stephenson, of Virginia, presided. At this convention the present rule of the Democratic party requiring a two-thirds vote to insure a nomination was adopted. Martin Van Buren was then unanimously nominated for President, and Richard M. Johnson, of Kentucky, was chosen for Vice-President, receiving 178 votes to 87 votes for William C. Rives, of Virginia. Gen. William H. Harrison, of Ohio, the opposition candidate to the Democracy in 1836, was nominated by a State convention in Pennsylvania and by several other bodies.

In 1839 a national Whig convention was held in Harrisburg, Pa. James Barbour presided, and Gen. Harrison was nominated for President on the first ballot, receiving 148 votes. John Tyler, of Virginia, was selected as Vice-President. In December, 1839, a convention of Abolitionists was held at Warsaw, N. Y., and nominated James G. Birney, of New York, for President and Francis J. Lemoyne, of Pennsylvania, for Vice-President. On May 5, 1840, a national Democratic convention assembled at Baltimore and Martin Van Buren was unanimously renominated, but no choice was made for a Vice-President. This was the first convention to frame a platform, declaring the ideas and wishes of the party.

A national Whig convention met at Baltimore on May 1, 1844, nominated Henry Clay, of Kentucky, for President by acclamation; and chose for Vice-President T. Frelinghuysen, of New Jersey. On May 27 the national Democratic convention met in the same city. The two-thirds rule was adopted, and after a session of 3 days James K. Polk, of Tennessee, was nominated for President. Silas Wright, of New York, was selected for Vice-President, but declined, and George M. Dallas, of Pennsylvania, was chosen to fill his place. On the first ballot Martin Van Buren had 146 votes, Lewis Cass 83, R. M. Johnson 29, and James Buchanan 4. Van Buren's name was withdrawn after the 8th ballot; and on the 9th Polk received 233 votes, to 29 for Cass and 2 for Van Buren. The national convention of the Liberty party met in Buffalo, N. Y., Aug. 30, 1844, and nominated James G. Birney, of

Michigan, for President and Thomas Morris, of Ohio, for Vice-President.

The national Whig convention of 1848 was held in Philadelphia, June 7-10, Gen. Zachary Taylor being nominated for President on the 4th ballot and Millard Fillmore, of New York, for Vice-President. Taylor's principal competitor was Clay. The national Democratic convention assembled at Baltimore, May 22, 1848; Lewis Cass was selected as the candidate for the Presidency on the 4th ballot; and William O. Butler, of Kentucky, for Vice-President. The Free Soil Democratic convention assembled on June 22, 1848, at Utica, N. Y., but only 3 States were represented. It placed in nomination Martin Van Buren for President and Henry Dodge for Vice-President. The latter subsequently declined. On Aug. 9 a larger convention of those holding Free Soil views met in Buffalo, 17 States being represented by delegates. This body nominated Martin Van Buren for President and Charles Francis Adams for Vice-President. (See FREE SOIL PARTY.)

The national Whig convention of 1852 assembled on June 16, in Baltimore, and was in session 6 days, during which time 53 ballots were taken, commencing with 131 for Gen. Winfield Scott, 133 for Fillmore, and 29 for Webster; and continuing, with very little variation, until the last, when Scott had 159, Fillmore 112, and Webster 21. In the same city the national convention of the Democratic party met on June 1, and on the 49th ballot selected Gen. Franklin Pierce, of New Hampshire, as its candidate for the Presidency. The 1st ballot stood: Cass, 116; Buchanan, 93; Douglas, 20; Marey, 27; Lane, 13; Houston, 8; Dodge, 3; Butler, 2; and Dickinson, 1. Cass rose to 131 on the 35th ballot, when the name of Pierce was presented, and on the 49th ballot the vote stood: Pierce, 282; Cass, 2; Buchanan, 2; Butler, 2. W. R. King, of Alabama, was then nominated for the Vice-Presidency. The Free Soil Democrats held a national convention at Pittsburg on Aug. 11, 1852, and nominated John P. Hale, of New Hampshire, for the Presidency, and George W. Julian, of Indiana, for Vice-President.

The first national Republican convention was held on June 17, 1856, at Philadelphia. (See REPUBLICAN PARTY.) After an informal ballot which resulted as follows, Fremont, 359, McLean, 196, John C. Fremont was declared nominated. Upon the same ticket was placed William L. Dayton, of New Jersey, as Vice-President. The American national council met in Philadelphia Feb. 19, 1856, and nominated Millard Fillmore for President and Andrew Jackson Donelson for Vice-President. The Democratic convention of 1856 met at Cincinnati on June 2, and cast 17 ballots. The 1st ballot stood: Buchanan, 135; Pierce, 122; Douglas, 33; Cass, 5. Pierce's votes were given to Douglas on the 15th ballot, but without effect; and on the 17th Buchanan was nominated.

The national Republican convention met in Chicago May 16, 1860, with delegates in attendance from all the free States, and also from Delaware, Maryland, Virginia, Kentucky, Missouri, Texas, and the Territories of Kansas and Nebraska, and the District of Columbia. Three ballots were taken for President, each delegate casting a half-vote; on the last the vote was: Lincoln, 231½; Seward, 180; Chase, 24½; Bates, 22; McLean, 5; Dayton, 1; C. M. Clay, 1. As this gave Lincoln within 2½ of a nomination, several delegations changed their ballots and gave him 354 votes. Hannibal Hamlin was nominated for Vice-President. A convention of the Constitutional Union party met in Baltimore on May 9, and nominated John Bell, of Tennessee, for President, and Edward Everett, of Massachusetts, for Vice-President. The national Democratic convention of 1860 met in Charleston, S. C., on April 26, delegates being present from all the States. The Territories are not allowed a vote in

Democratic conventions. After a stormy debate upon a platform a part of the delegates left the convention, and those that remained proceeded to ballot. The 1st ballot stood: Douglas, 145½; Guthrie, 35; Hunter, 42; Dickinson, 7; H. V. Johnson, 12; Lane, 6; Jefferson Davis, 1½; Toucey, 2½; Pierce, 1. The 57th ballot stood: Douglas, 151½; Guthrie, 68½; Hunter, 16; Dickinson, 4; Lane, 14; Davis, ½. The convention then adjourned to meet in Baltimore June 13, and there on the 2d ballot Stephen A. Douglas was declared the choice of the convention for President, and Benjamin Fitzpatrick, of Alabama, was nominated for Vice-President. When he declined Herschel V. Johnson, of Georgia, was put in his place. The delegates who had withdrawn from the Charleston convention immediately assembled at St. Andrew's Hall, in that city, and, after adopting a series of resolutions, adjourned to meet in Richmond, Va., on June 10. This body, after a number of meetings, finally indorsed the nomination of Breckinridge and Lane. On June 28 the delegates who did not participate in the convention that nominated Douglas and Johnson assembled in Baltimore, and proceeded to ballot for a candidate for President. John C. Breckinridge, of Kentucky, received the unanimous vote of the 105 delegates present, representing 20 States. For Vice-President Gen. Joseph Lane, of Oregon, was nominated.

On May 31, 1864, a convention to organize a new party under the name of the "Radical Democracy" met at Cleveland, issued an address to the people, and nominated John C. Fremont for President, and John Cochrane, of New York, for Vice-President. These candidates were subsequently withdrawn. The national Republican convention of 1864 assembled in Baltimore on June 7; Robert J. Breckinridge, of Kentucky, was its president. Abraham Lincoln was renominated on the 1st ballot by a unanimous vote, with the exception of the vote of Missouri, which was cast for Grant. For Vice-President Andrew Johnson was nominated on the 1st ballot. The national Democratic convention of 1864 met at Chicago, Aug. 20. Horatio Seymour, of New York, was appointed permanent chairman. The vote was: George B. McClellan, 202½; Horatio Seymour, 23½. George H. Pendleton was nominated for Vice-President on the 2d ballot.

The national Republican convention met at Chicago May 21, 1868. Gen. Joseph R. Hawley, of Connecticut, was selected as President. A ballot was taken, and the president announced that 610 votes had been cast, all for Ulysses S. Grant. On the 5th ballot for Vice-President Schuyler Colfax, of Indiana, received 522 votes and was nominated. On July 4, 1868, the national Democratic convention met in New York, Horatio Seymour presiding. The 1st ballot resulted: Pendleton, 105; Hancock, 33½; Church, 34; English, 16; Parker, 13; Packer, 26; Johnson, 65; Doolittle, 13; Hendricks, 2½; Blair, ½. On the 21st ballot the vote was: Hancock, 135½; English, 19; Johnson, 5; Doolittle, 12; and Hendricks, 132. On the 22d ballot all the States voted for Horatio Seymour, and he was declared the nominee. Gen. Frank P. Blair, of Missouri, was unanimously nominated for Vice-President.

The national convention of the Liberal Republican party met in Cincinnati on May 1, 1872, and opened the Presidential campaign of that year. Six ballots were taken. On the 1st Horace Greeley received 147 votes; C. F. Adams, 203; Trumbull, 110; Davis, 92½; Brown, 95; Curtin, 62; Chase, 2½. On the 5th ballot Greeley had 258, and Adams 309; but on the 6th ballot Horace Greeley was declared the nominee of the convention for President. On the 2d ballot B. Gratz Brown, of Missouri, was selected for Vice-President by a vote of 435 to 261. The national Republican convention of 1872 assembled in Philadelphia on June 5. Morton McMichael was chosen

temporary chairman, and Thomas Settle, of North Carolina, as permanent president. On the 1st ballot Ulysses S. Grant received the entire vote. For Vice-President Henry Wilson, of Massachusetts, was nominated over Schuyler Colfax on the 2d ballot. The national Democratic convention met at Baltimore, July 9, 1872, and all the ballots but 45 were cast for Greeley, who was declared the candidate for the party. B. Gratz Brown was nominated for Vice-President.

The convention of the Republican party for 1876 met at Cincinnati on June 15, having 752 members. Edward McPherson, of Pennsylvania, was permanent chairman. On the 1st ballot James G. Blaine had 285 votes; Morton, 125; Bristow, 113; Conkling, 99; Hayes, 61; Hartranft, 58; Jewell, 11; Wheeler, 3. The 7th ballot resulted: Blaine, 351; Bristow, 21, and Hayes, 384, or 5 more than a majority. William A. Wheeler received 366 votes for Vice-President on the 1st ballot. The Democratic convention met in St. Louis June 27. On the 1st ballot S. J. Tilden had 403½ votes; Hendricks, 133½; Allen, 56; Hancock, 75; Parker, 18; Bayard, 27. On the 2d ballot Tilden had 508, and was declared nominated; and Thomas A. Hendricks was unanimously nominated for Vice-President. A convention of the Prohibition party met at Cleveland May 16, 1876, and nominated Green Clay Smith, of Kentucky, for President, and G. S. Stewart, of Ohio, for Vice-President. A Greenback convention was held at Indianapolis May 17, which nominated Peter Cooper, of New York, for President, and Newton Booth, of California, for Vice-President. Mr. Booth afterwards declined, and Samuel C. Cary, of Ohio, was substituted.

The national Republican convention of 1880 met at Chicago, June 2. It was a notable gathering of distinguished Republicans. Gen. Grant had just returned from a remarkable journey around the world, and a large portion of the Republican party desired to make him a candidate for a third term. George F. Hoar, of Massachusetts, was selected as temporary chairman, and subsequently made permanent president of the convention. Edwards Pierpont, of New York, reported the platform. After sharp preliminary contests the first ballot was taken on the fifth day of the convention, and stood: Grant, 304; Blaine, 284; Washburne, 31; Edmunds, 34; Windom, 10; John Sherman, 93. The balloting continued for 2 days, and the 36th ballot stood as follows: Grant, 306; Garfield, 399; Blaine, 42; Washburne, 5; Sherman, 3. James A. Garfield, of Ohio, thus had a majority, and Roscoe Conkling, of New York, who had led the Grant forces, made the motion that the nomination be unanimous. Chester A. Arthur, of New York, was then nominated for Vice-President on the 1st ballot, receiving 468 votes. The Democratic convention of 1880 met at Cincinnati on June 22. A considerable number of Democrats believing that Mr. Tilden had been defrauded of the election in 1876 urged his renomination. The 1st ballot taken on the 3d day stood as follows: Winfield S. Hancock, 171; Thomas F. Bayard, 153½; Stephen B. Field, 65; William R. Morrison, 62; Thomas A. Hendricks, 49½; Allen G. Thurman, 68½; Henry B. Payne, 81; Samuel J. Tilden, 38; Thomas Ewing, 10; Horatio Seymour, 8; scattering, 22. On the 4th day the final ballot was taken with this result: Hancock, 705; Hendricks, 30; Tilden, 1; Bayard, 21; and the nomination of Hancock was made unanimous. William H. English was nominated for Vice-President by acclamation. An unsuccessful attempt was made to change the two-thirds rule, which still holds in Democratic conventions. The national Prohibition convention met at Cleveland, on June 17, and nominated Neal Dow for President, and A. H. Thompson for Vice-President. The Greenback party met at Chicago June 11, and nominated James B. Weaver, of Iowa, for President, and B. J. Chambers, of Texas, for Vice-President.

In 1884 the Republican convention met at Chicago on June 3. For the first time the new system of representation by delegates elected in Congressional districts was in force. Government office-holders were excluded from the national committee and from the Presidential electors. The scheme proposing that States and districts should be represented in the convention in proportion to the number of Republican votes cast by them had failed. The 1st ballot stood: Blaine, 334½; Arthur, 278; Edmunds, 93; Logan, 63½; Sherman, 30; Hawley, 13; Lincoln, 4; William T. Sherman, 2. On the 4th ballot James G. Blaine received 541 votes and was declared the nominee for President. No opposition was made to the nomination of John A. Logan for Vice-President. The national Democratic convention also met at Chicago, July 8. On the 3d day the 1st ballot stood: Grover Cleveland, 392; Thomas F. Bayard, 170; Allen G. Thurman, 88; Samuel J. Randall, 78; Joseph McDonald, 56; John G. Carlisle, 27; scattering, 9. On the 4th day Cleveland was nominated by the following vote: Cleveland, 683; Hendricks, 45½; Bayard, 81½; McDonald, 2; Randall, 4; Thurman, 4. Hendricks was nominated for Vice-President without opposition. John P. St. John was nominated for President by the Prohibitionists; and Benjamin F. Butler by the Greenback and Labor parties.

In 1888 the Republicans met in Chicago, June 19. The 1st ballot was taken on June 22 with the following result: John Sherman, 229; Walter Q. Gresham, 107; Chauncey M. Depew, 99; Russell A. Alger, 84; Benjamin Harrison, 79; William B. Allison, 72; James G. Blaine, 33; John J. Ingalls, 28; William Walter Phelps, 25; Jeremiah M. Rusk, 25; Edwin H. Fidler, 24; Joseph R. Hawley, 13; Robert T. Lincoln, 3; William McKinley, Jr., 2. The 8th and final ballot, taken on June 25, resulted as follows: Harrison, 544; Sherman, 118; Alger, 100; Gresham, 59; Blaine, 5; McKinley, 4. Gen. Benjamin Harrison, of Indiana, being thus the choice for President, Levi P. Morton was nominated for Vice-President. At the Democratic convention of 1883, held in St. Louis on June 5, there was no opposition to the renomination of Pres. Cleveland. The convention, without a division, nominated Allen G. Thurman, of Ohio, for Vice-President. Gen. Clinton B. Fisk, of New Jersey, was nominated for the Presidency at the convention of the Prohibition party, and Rev. John A. Brooks, of Missouri, for the Vice-Presidency. There were some minor conventions which also nominated candidates.

(F. G. M.)

POLITICAL ECONOMY.

While the article in the *ENCYCLOPÆDIA BRITANNICA* gives an excellent sketch of the general history and tendency of the science of Political Economy, the aim of the present article is to give an outline of the labors of Americans in this important field. If the work done in the United States for the development of this science be measured by the number and weight of the systematic treatises, it will appear much less than in England, and perhaps three of the countries on the continent of Europe. But if it be taken into account that in America the discussions of such subjects are represented less by books and pamphlets than by newspapers, articles in periodicals and the debates before the people in the national legislature and in political canvasses, it will be found that in no other country has the science been more sedulously cultivated and more profitably employed than with us. From the very foundation of our national government in 1789 the problems of currency and banking, taxation, immigration, slavery, protection to home industry, and the administration of public debts have formed integral parts in our political discussions, and in later times those of capital in its relation to labor, the administration of charities, and the pretensions of communism and socialism have been ad-

See Vol. XIX. p. 346 (p. 359 Am. Rep.).

ded to the number of themes handled in our great national university.

In colonial times these questions were not much agitated, American ideas being in this field as in others little more than reproductions of those of England. It was the proposal to place the national finances upon a better footing by appointing a supervisor of finance which incited Peletiah Webster to write his *Political Essays* (1781). Similarly it was Lord Sheffield's *American Commerce* (1783) which provoked Tench Coxe to reply in his *Examination* of that audacious book, showing that the colonies had not plunged into commercial ruin by achieving their independence, but had at hand all the elements of industrial prosperity, and were quite able to take care of themselves. After the formation of "a more perfect union" under the Constitution, the duty of chief adviser of the country in economical matters fell upon Alexander Hamilton, the greatest statesman of his age, in Niebuhr's estimation. His *Treasury Report on the Tariff* (1791) and on a national bank (1790), together with his practical administration of our finances, laid the foundation of American policy in these matters. Not that there were no theoretical dissenters from the national policy. The fact that Adam Smith's *Wealth of Nations* was thrice reprinted in the United States, and that Say's treatise appeared here in an early translation, denote the contrary. Two other foreign text-books were the translations of Destutt de Tracy published in 1817, with an introduction by Jefferson, and of Charles Gannil in 1812.

The agitation over the tariff after the second war with Great Britain produced a shower of pamphlets, of which the most notable are those of Mathew Carey: *Addresses of the Philadelphia Society* (1816); *The New Olive Branch* (1820); *Essays on Political Economy* (1822). The same discussion produced our first attempts at a systematic presentation of the science: Daniel Raymond's *Elements of Political Economy* (1823); Thomas Cooper's *Elements of Political Economy* (1826); *A Summary of the Practical Principles of Political Economy by a Friend of Domestic Industry* (1826); Willard Phillips's *Manual of Political Economy with Particular Reference to the Institutions, Resources, and Condition of the United States* (1828); Friedrich List's *Outlines of American Political Economy* (1827), and Jennison's *Outlines of Political Economy* (1828). All of these are vindications of the protectionist policy, except that of Prof. Cooper, of South Carolina (see COOPER, THOMAS), which repeats the passionate propaganda of Free Trade which he had been conducting on congenial soil in the South. He speaks of manufactures as though they were little else than a blight to the nation. The works of Raymond and Phillips are written with ability and acuteness. That of List, who was a resident of Pennsylvania at that time, foreshadows the principles of his later *Nationalökonomie* (1841).

In the next decade the Protectionists are represented only by Oliver Putnam's *Tracts on Sundry Topics of Political Economy* (1834) and John Rae's *New Principles of Political Economy* (1834). But the work of Rae, by birth a Scotchman, is recognized by Senior and Mill as one of the ablest in the whole field. On the other side we have Prof. Samuel Newman's *Political Economy* (1835), that of Dr. Francis Wayland, of Brown University, first published in 1838 and often reprinted, before its recast by Prof. Chapin (1886); and Henry C. Carey's *Elements of Political Economy* (1837-40). Dr. Wayland's was one of the most superficial books ever written on the subject, but its clear and graceful style gave it the greatest popularity ever enjoyed by any economic text-book in America. Mr. Carey's *Elements* represent his first stage, in which his revolution of the accepted teachings of Political Economy, so far from bringing him into collision with

the *laissez-faire* principle, had made him an earnest adherent of it. On the same side was his friend Condy Raguet, whose treatises *On Currency and Banking* (1839) and *Principles of Free Trade* (1835-1840), together with the three economic periodicals he successively edited, entitle him to remembrance as an acute and forcible writer.

The adoption of the protective tariff of 1842 marks a turning-point in the development of Mr. Carey's ideas. Neither then nor afterwards did he abandon those convictions which arrayed him against the "dismal science" of the English economists. He remained a conditional optimist in his belief that "Men pass from what is worse to what is better in land, in labor, and in food." He still asserted that the economic laws were designed to secure a constantly increasing return for human labor in subduing nature, and thus reducing values, and to effect a more equal distribution between capitalist and workman, between landlord and tenant. He still contended that where the misery of the savage is found within the scope of civilization, somebody is to blame. But the effects of the nation's return to the protective policy satisfied him, after some years of reflection and further study, that he had underestimated the power of the wealthier and more advanced countries to check the growth of economic association in others, and to secure to themselves what English economists taught were the more remunerative industries. After several years of silence he announced his new conclusions in *The Past, the Present and the Future* (1848) and in *The Harmony of the Interests* (1850). In the meantime four other authors had announced the same inferences from our economic experience: A Southern Planter in *Notes on Political Economy as applicable to the United States* (1844); Ezra C. Seeman in his *Progress of Nations* (1846-68); Rev. Calvin Colton, the friend and biographer of Henry Clay, in his *Public Economy for the United States* (1848); and Willard Phillips in his *Propositions Concerning Protection and Free Trade* (1850), a searching examination of Adam Smith's principles. On the other side the most notable publication was the *Treasury Report* of Mr. Robert J. Walker in 1846, which may be said to have been answered by that of Mr. William M. Meredith in 1849.

The decade before the civil war was taken up with the discussion of Slavery, and it is notable that its moderate opponents, such as Dr. Channing, pressed the consideration that it was an economic mistake, as has been proven since the war. On the Free Trade side at this time there appeared a short systematic treatise by George Opydyke, of New York, in 1851, which aims at a new treatment of the subject, but made little impression: *Political Economy for the People* (1859) by the veteran George Tucker, of Virginia, who in 1837, 1839, and 1857 had published works on the currency; and *The Science of Wealth, a Manual of Political Economy*, by Amasa Walker, a practical banker, who also was lecturer on the subject in Amherst College. It was by far the ablest of the orthodox treatises which had appeared in this country, and reached its fifth edition after its author's death. On the protectionist side are *Principles of Political Economy* (1835) by E. Peshine Smith, a disciple of Carey, but with a good deal of originality of his own; Prof. Francis Bowen's *Principles of Political Economy* (1854); the translation of Friedrich List's *National Economy* (1858), with an elaborate historical and critical "Introduction" by Stephen Colwell, whose own book on the currency problem, *The Ways and Means of Payment* (1859), never has been surpassed either in historical learning or wealth of practical suggestion. Above all Henry C. Carey in 1858-59 published his own system in definitive shape in his *System of Social Science*, which has been translated into more languages than any other economic work except perhaps those of Adam Smith and J. Stuart Mill.

The next decade (1860-70) saw few books on the

general subject, although the great monetary discussions raised by our fiscal policy during the war had already begun. In 1864 Prof. Bowen published *Political Economy Applied to the Conditions and Institutions of the American People*, in which hard money and moderate advocacy of Protection are leading features. Prof. A. L. Perry published in 1866 his *Elements of Political Economy*, following Carey and Bastiat in his conception of value, but advocating the *laissez faire* theory without reservation. In 1869 Horace Greeley, the veteran editor, collected into a book his *Essays to Elucidate the Science of Political Economy*, chiefly occupied with the tariff and coöperation. Mr. Andrew W. Young in 1866 published under the title *National Economy* an historical account of the great debates on the tariff question in this country. In 1870 Dr. William Elder gave the public a popular exposition of Mr. Carey's leading doctrines in *Questions of the Day*.

The next decade (1871-80) witnesses the division of the economists who look to Europe for light and leading into two schools. The new Historical School founded by Roscher in Germany began to find disciples in America. Prof. Francis Walker, a son of Amasa Walker, published *The Wages Question* (1876), *Money* (1878), *Money, Trade and Industry* (1879), in which the new views of labor and the functions of government are presented, and bimetallism is defended. Since that time the new school has grown rapidly, and now much more than outnumbers its orthodox rival in the leading universities of the country. On the other side Prof. William G. Sumner, of Yale, represents the old method and the old doctrines of English Political Economy with an energy peculiar to himself, in his *History of American Currency* (1874), his *Lectures on the History of Protection in the United States* (1877), and other works. On the protectionist side are Prof. R. E. Thompson, who in his *Social Science and National Economy* (1875), revised under the title *Elements of Political Economy* (1882), seeks to combine the views of List with those of Carey; Prof. Bowen's *American Political Economy* (1877); Orin Skinner's *Issues of American Politics* (1873); Prof. Albert S. Bolles's *Chapters in Political Economy* (1874) and his *Financial History of the United States* (3 vols., 1879-83), besides pamphlets by John L. Hayes, George Basil Dixwell, Cyrus Elder, and David H. Mason.

The resumption of specie payments in 1879 may be said to have disposed of that controversy, only to leave the country leisure for a prolonged discussion first of the Silver question, and then of the question of Free Trade vs. Protection. In the former controversy the case for remonetization has been ably maintained by Mr. S. Dana Horton in *The Silver Pound* (1887) and other works, by Mr. Balche as an American interpreter of the ideas of Cernuschi, by Prof. Francis A. Walker, Hon. Wm. D. Kelley, and many others; and the Report of the Congressional Commission on the question is of permanent value. On the other side were Prof. Sumner, Prof. J. L. Laughlin, of Harvard, in his *History of Bimetallism in the United States* (1886), and the orthodox economists generally. In that on Protection Prof. Sumner has been the foremost champion of Free Trade, as is shown in his *Economic Problems* (1884), and *Protectionism* (1885). Next to him comes Mr. Henry George, whose very readable *Protection and Free Trade* is marred by readiness to catch at any loose statement made by an opponent, and by extremism. It advocates the entire abolition of custom-houses and the substitution of a single tax on land for all others. Mr. David A. Wells, Mr. J. S. Schoenhof, Prof. F. W. Taussig in his *History of the Tariff* (1888), and others have been earnest fighters on that line, and Prof. R. T. Ely has advocated Free Trade in his *Problems of To-day* (1888) from the standpoint of the new school which rejects the *laissez faire* premise of that policy. On the other side are Mr. Giles B. Hawley's *Capital and Population* (1882); Mr.

Ellis D. Roberts's *Government Revenue* (1884); Prof. Robert Ellis Thompson's *Harvard Lectures on Free Trade and Protection* (1885); Mr. Robert P. Porter's *Breadwinners Abroad* (1885); Hon. Henry M. Hoyt's *Protection versus Free Trade* (1886); Mr. Giles B. Stebbins's *Protectionist's Manual* (1883); Mr. Richard W. Thompson's *History of Protective Tariff Laws* (1888); Mr. Henry V. Poor's *Twenty-two Years of Protection* (1888); and Mr. David H. Mason's *Short Tariff History of the United States*, Part I. (1884), besides pamphlets by John Welsh, Joseph Wharton, Horace Castle, John F. Seanlon, Henry Hall, Thomas H. Dudley, and many others. Arguments from both sides will be found in Mr. H. W. Furber's *Protection and Free Trade, Both Sides* (1888) and in Dr. Albert Shaw's *The National Revenues: a Collection of Papers by American Economists* (1888).

Parallel with these two controversies, and at times running into the second, has been the discussion of the relations of rich and poor, wage-earners and wage-payers, which has come to be recognized as an economic problem since the discredit of the wage-fund theory by Thornton and Mill. In America the condition of labor has been a matter of public concern ever since the rise of the factory system and the consequent formation of a class who live by wages outside of personal relations to their employers of any intimate sort. Mr. George's theories of land nationalization and the single tax, set forth in his *Progress and Poverty* (1879) and *Social Problems* (1884), have given a notable impulse to the discussion. Mr. Wm. G. Moody in *Land and Labor in the United States* contends that machinery has made the reduction of the hours of labor to six imperative, if we are to find work for our people. Mr. George Gunton in *Wealth and Progress* (1887) maintains that the rate of wages is fixed by the standard of living, that this can be raised only by increasing the social opportunities of the laboring classes, and that the readiest means to this is a reduction of the daily hours of labor. Mr. Laur. Gronlund in *The Coöperative Commonwealth* (1884) contends for the entire overthrow of the competitive system and the absorption of all productive energies by the state. These are specimens of the teachings which are stirring the laboring population of all Christendom like a ferment. The only notable attempt to assert the old economic indifference to them is in Prof. Sumner's *What Social Classes Owe to Each other*. (1883). Genuinely radical is the demonstration offered by Mr. Edward Atkinson of the truth of the law of equalizing distribution first formulated by H. C. Carey, which he presents in *The Distribution of Products* (1885) and *The Margin of Profits* (1887). Mr. Wm. B. Weedon in *The Social Law of Labor* brings the light of general sociological development to bear on the problem. It is taken up in the light of Christian principle in Rev. Washington Gladden's *Working People and their Employers* (1885); in Dr. T. Edwin Brown's *Studies in Socialism* (1886); and in Prof. Richard T. Ely's admirable book, *The Labor Movement in America* (1886).

Of systematic treatises in this period there are Simon Newcomb's *Political Economy* (1887) and Prof. J. L. Laughlin's *The Elements of Political Economy* (1887), which belong to the orthodox school, as does the latter's abridgment of Mill (1884) with valuable additions; also translations of Roscher and Laveleye and Prof. F. A. Walker's *Political Economy* (1883), which represent the new Historical School; as does Dr. Simon N. Patten's *Premises of Political Economy* (1884). On the Protectionist side, to which Dr. Patten also belongs, there are Dr. Steele's *Lessons in Political Economy* prepared for the Chautauqua students, and Dr. Van Buren Denslow's *Principles of Economic Philosophy of Society, Government and Industry* (1888).

A marked feature of the decade has been the enlargement of the facilities for economic study in the leading universities of the country—Harvard, Yale,

Columbia, Pennsylvania, Johns Hopkins, Cornell, and Michigan. With this has come the formation of organizations to bring together the teachers of the science, the Political Economy Club representing orthodoxy more or less, and the American Economic Association the new tendencies. Finally, at Harvard, Columbia, Pennsylvania, and Johns Hopkins there are series of publications, in which economic and related questions are treated. (R. E. T.)

POLK, LEONIDAS (1806-1864), bishop and general, was born at Raleigh, N. C., in 1806. He graduated at West Point in 1827 and entered the artillery, but soon resigned. After a course of theological study he was ordained to the Episcopal ministry in 1831, and was made missionary bishop of Arkansas and the Indian Territory in 1838. He took charge also of the adjoining diocese until 1841, when he was made bishop of Louisiana. After twenty years' service in this capacity he accepted the appointment of major-general in the Confederate army. He took command at Columbus, Tenn., and unsuccessfully endeavored to obstruct the passage of the Mississippi to Union forces. When Gen. Grant captured a Confederate camp at Belmont Polk crossed from Columbus, but did not prevent the accomplishment of Grant's object. He afterwards had command of a division and fought at Stone River, Chattanooga, and Chickamauga. He was killed while reconnoitring near Marietta, Ga., June 14, 1864.

POLLOCK, FREDERICK, English lawyer and essayist, was born in London, Dec. 10, 1845. He is a grandson of Sir Frederick Pollock (1783-1870), who was chief baron of the exchequer. He was educated at Eton and Trinity College, Cambridge, of which he became a fellow in 1868. He was called to the bar at Lincoln's Inn in 1871, and in 1882 was made professor of jurisprudence at University College, London, in 1883 corpus professor of jurisprudence at Oxford, and in 1884 professor of common law. He is also editor of the *Law Quarterly Review*, and has contributed to various periodicals. Among his legal works are *Principles of Contract* (1875); *Digest of the Law of Partnership* (1877); *The Land Laws* (1883). To other departments belong *Spinoza, his Life and Philosophy* (1880), and *Essays in Jurisprudence and Ethics* (1882). His brother, **WALTER HERBERT POLLOCK**, was born in 1850, educated at Eton and at Trinity College, Cambridge, graduating in 1871, and was called to the bar at Inner Temple in 1874. He has delivered many lectures on historical and literary subjects, and in 1884 became editor of *Saturday Review*, with which he had long been connected. His publications include *Lectures on the French Poets; Songs and Rhymes, English and French; Verses of Two Tongues; and The Poet and the Muse*.

POLYGAMY (Gr. *πολῆς*, many, and *γάμος*, marriage) means multiple marriage, i. e., the condition of a man having two or more wives, or of a woman having two or more husbands at the same time. Recent writers on sociology have distinguished these two kinds of polygamy by different names, calling the former "polygyny" (many wives), and the latter "polyandry" (many husbands). Opposed to polygamy is that form of the marriage relation called "monogamy" (single marriage), by which one man is forbidden to have more than one wife, or one woman to have more than one husband at the same time. Although from a scientific point of view this terminology is both convenient and accurate, yet it is not in accordance with popular usage. As commonly employed the word "polygamy" designates exclusively that form of the marriage relation in which one man has several wives at the same time, and it is in this sense that we shall use it in the present article. Polyandry, the condition of a woman having several husbands, though much more extended than is commonly supposed, many intelligent persons being ignorant of its existence in any part of the world, is comparatively limited and excep-

tional. It exists among the aboriginal inhabitants of the island of Ceylon and in Thibet. In both these countries, however, it is usually restricted to the case where all the husbands of one wife are brothers or half-brothers. Among other barbarous tribes where it is said to exist, as the Fuegians, the Aleutians, many of the Pacific islanders and some of the native tribes of Hindustan, polygamy also exists, and the two form a system hardly distinguishable from promiscuous intercourse. Polygamy, in the sense of one man having several wives, is far more frequent and widely extended. It exists in every latitude and every climate, in Asia, in nearly the whole of Africa, in Australia and most of the islands of the Pacific, and on the western continent and the adjacent islands among the aboriginal tribes from the Esquimaux and Aleutian islanders in the extreme north to the Patagonians and Fuegians in the extreme south. It has existed from the remotest periods of antiquity, and traces of it are to be found in the history of almost every race. Nor has polygamy been confined to barbarous nations. The Egyptians, Hebrews, and Persians were among the most civilized peoples of ancient times, and in the middle ages the Moors of Spain were at one time the foremost nation in Europe in literature, science, and art; yet polygamy was practised among them all. Taking into consideration all nations, past and present, barbarous and civilized, it cannot be doubted that the peoples among whom polygamy has been and is allowed far exceed in numbers those among whom it has been and is prohibited.

The only widely extended religion by which polygamy is at the present time expressly sanctioned is the Mohammedan. Even by that the number of wives a man may lawfully marry is limited to four (see Koran, cap. 4), but in practice the number is only limited by his wealth and his inclination. The Mohammedan religion has, during the present century, extended itself greatly among the barbarous tribes of Africa. This, however, has not really extended polygamy, as that custom prevailed among those tribes previous to the introduction of Mohammedanism. The fact that Mohammedanism sanctions polygamy has greatly facilitated the spread of that religion among the barbarous tribes where the custom already existed. In all Christian nations (which is equivalent to saying in all the most highly civilized nations) polygamy is regarded as a sin, and is prohibited by law as a crime.

Old as polygamy is historically and widely extended as it is geographically, a closer examination shows that practically this extension is more apparent than real. Inhabitants of highly civilized countries who have never given the subject any special examination, when they hear or read about a country in which polygamy is allowed, are apt to imagine that in such a country every married man has three or four wives. This has also been frequently asserted by travellers. Such statements necessarily imply either that the adult female population is three or four times greater than the male, or that only a small fraction of the male population have any wives at all unless polyandry exists at the same time. Excluding this latter case, which is of limited extent, there is no evidence that either of the above conditions has ever existed for any great length of time in any community of any considerable size. It is fully established that among all races of mankind the number of male infants born slightly exceeds the number of female, the ratio being about twenty-one males to twenty females. From physiological causes, into the nature of which it is not necessary to enter here, the number of deaths among male infants slightly exceeds that among female. After arriving at adult age the occupations of men, even in the most civilized and peaceable communities, expose them to death by accident more frequently than women. On the other hand the female sex is alone exposed to the accidents and perils of child-bearing. Taking the human race as a whole the numbers of married and

marriageable men and women are practically equal. What is true of the race is, in the great majority of cases, true of any particular community or nation. Exceptional causes sometimes interfere with this equilibrium of the sexes. Neighboring tribes of savages constantly engaged in war with each other sometimes show a great preponderance of the female population, owing to the number of men slain in war. Such cases are mostly confined to the lowest type of savages. It is quite certain that no considerable portion of the human race has ever been in such a condition that a majority of the men could each have as many as two wives. Hence, even among barbarians, the practice of polygamy is usually confined to a small minority of the males.

Among highly civilized nations economic tendencies sometimes temporarily disturb the equilibrium of the sexes in particular localities. Thus, when gold was discovered in California there was a great rush of the male population of other countries to that territory. The same thing happened afterwards in the case of Australia.

Although the preponderance of the male population in those countries was for a time very great, yet its ratio to the population of the countries whence it came was so small that it had upon them no perceptible effect. In the United States there is a constant emigration of young unmarried men from the Eastern to the Western States. This tends to produce an excess of males in the West and of females in the East. But the means of rapid and cheap transit have so greatly increased during the last half century, the opportunities for self-support afforded to the female sex have been so multiplied, and the tendency of both sexes not to enter the marriage state until they have a reasonable prospect of being able to rear a family in a social condition at least equal to their own has so much increased, that they have more than counterbalanced any effects of the slight inequality of the sexes thus produced. Even in a community when from some cause the female population had become so great in comparison with the male as to render it possible for each man to have three or four wives, unless that cause were constant in its operation, natural laws would in a few generations bring about an equality of the sexes, and polygamy, though tolerated by law and custom, would inevitably be confined to a small minority of the male population.

Another circumstance tends to restrict the practice of polygamy. Where a people is so far advanced in civilization as to have a permanent abiding place and to depend for support principally upon its industry, each one of the great majority of the male population finds the support of one wife and her children all that he is able to achieve, and thus polygamy can only be practised by the wealthy and powerful, who necessarily constitute a small minority. Hence though polygamy was allowed by the Gauls, Germans, and other barbarous races from which the modern nations of Europe are in great part descended, yet practically it was confined to the chiefs, and as a rule among the mass of the people each man had but one wife.

During the flourishing periods of the Greeks and Romans no man among them could have more than one legitimate wife at the same time. As fast as the barbarous nations that overthrew the Roman empire were converted to Christianity the last remnants of polygamy were blotted out.

In its effects on the family nothing can be said in favor of polygamy except in comparison with those lower conditions of mankind where the domestic relations can hardly be said to exist. When it exists among barbarous tribes the husband regards his wives as so much property and treats them as slaves. The women are compelled to do all the labor, and hence they do not object to an increase in the number of wives, thinking that by this means the amount of work which each will have to perform will be lessened. In

more civilized countries, where polygamy is confined to the rich and the powerful, the number of a man's wives is looked upon as an index of his rank, and the women are hence led to regard it with favor as an indication of their own higher position. Travellers in countries where polygamy is allowed are unanimous in their testimony that the mutual respect and affection of husband and wife, which in countries where monogamy is only permitted is regarded as constituting the highest ornament of the ideal family, is almost unknown. The husband regards his wives merely as the instruments of his pleasures, and considers himself as having discharged his whole duty to them when he has provided for their physical comfort; and the wives look upon the husband simply as a master from whom they must get all they can by artifice but can demand nothing as a right.

The effect upon the children is in the highest degree deleterious. Where there are groups of children by different wives either the paternal care and authority is dissipated among so many as to be of little account or it is concentrated upon some of the children to the neglect of the others. The rivalries, jealousies, and contentions of the wives are shared by the children and hatred rather than love is fostered. Hence in those countries where polygamy is practised by the rulers the old age of a monarch is a season of plotting and conspiracy, and his death is the signal for revolution and bloodshed.

A general review of the past history and present condition of the human race leads irresistibly to the following conclusions: 1st. In the vast majority of communities of any considerable size the number of married and marriageable men is substantially equal to the number of married and marriageable women. 2d. Whenever from any cause this equality is destroyed the natural laws which govern the reproduction of the human race will, if the cause ceases to operate, restore the equality. 3d. Except where the male population of a community is constantly reduced by continual warfare the practice of polygamy by a majority of the males becomes a physical impossibility, unless wives are obtained by capture or purchase from some other community, and this state of things is confined almost entirely to the lowest grades of humanity. Where polygamy exists in semi-civilized nations the number of women obtained by capture or purchase bears but a small ratio to the whole population, and such women are most frequently regarded as slaves and concubines, not as wives having equal rights with those legitimately married. 4th. Wherever polygamy has co-existed with a high state of civilization it has been confined to the wealthy and powerful, who are necessarily a small minority, and in such cases it has always been a survival from a previous state of barbarism. 5th. Natural laws, the progress of science and the industrial arts, and the spread of Christianity all tend with irresistible force to its final extirpation.

In modern times the attempt of the Mormons to revive polygamy within the limits of a Christian nation is the only one of such extent and importance as to demand attention.

In regard to this only a few words are necessary in addition to what will be found under MORMONS. When (1847) the members of this sect, after their expulsion from Illinois and Missouri, selected as their abiding place the region south of the Great Salt Lake, they were separated on all sides by a vast extent of unsettled country from all contact with civilization. They undoubtedly expected that many years, probably two or three generations, would pass before they would be interlarded with by the advancing tide of emigration from the East. When in 1850 they were organized into a Territory, Brigham Young was appointed governor, the other territorial offices were filled by members of their own sect, and the delegate elected by themselves was admitted to Congress, these expectations were strengthened. They hoped in a few years

to become sufficiently numerous to demand admission as a State. That object accomplished, polygamy, already established by custom, would immediately be sanctioned by law. All these calculations proved mistaken. The construction of the Pacific Railroad made communication on the east and the west rapid and easy, and they became exposed not only to transient observers but to the influx of a population protected by the force of the government and regarding the system of polygamy with loathing and disgust. Their polygamous delegate was expelled from Congress. The territorial offices were filled by men opposed to the institution. Finally polygamy was declared to be a crime, and those who practised it were deprived of the elective franchise and subjected to heavy penalties. Of course many difficulties have been met with in enforcing these laws, but there can be no doubt about the final result. Already discussions on this point are springing up among the Mormons themselves. It is reported that a large portion of those who are determined to maintain the institution of polygamy have purchased a tract of country in the northern part of Mexico and are about to remove thither. Those who remain where they now are will undoubtedly gradually abandon the practice. So long as Utah remains a Territory the authority of the government of the United States is absolute, and it is entirely certain that Utah will never be admitted into the Union as a State except under guarantees that will ensure the final extinction of an institution so opposed to the moral and religious convictions of the nation at large. (W. M. F.)

POLYTECHNIC SCHOOLS (derived from the Greek *πολις*, many, and *τεχνη*, art) are educational institutions intended for instruction in the practical applications of mathematics, physics, and chemistry. The first school bearing this name was founded in Paris in 1794 by the National Convention for the recruiting of the public service. In this the most eminent French scientists were instructors, and the pupils received an annual stipend from the government. The Emperor Napoleon afterwards required the pupils to pay their own expenses and gave the school a military organization, which it has since retained. Many of the most distinguished French scientists and mathematicians have been graduates of this institution.

Similar institutions have been founded in the United States by private enterprise, while the larger colleges and universities have formed their scientific departments on its model. The oldest of these institutions, the Rensselaer Polytechnic Institute of Troy, N. Y., was founded in 1824; and in the same year the Franklin Institute was organized in Philadelphia. These institutions are still in existence and have done much excellent work. From time to time other technical schools were founded, so that by 1848 the Ohio Mechanics' Institute was in existence and scientific departments had been added to Yale and Harvard Colleges and to the University of Virginia.

In 1829 the highly useful Central School of Arts and Manufactures was founded in Paris, while the School of Design from which has grown the school system of science and arts of Great Britain came into operation in 1837. A department of science and arts was formally added to the school system of Great Britain in 1856. The American movement in this direction was made national in 1862 by a congressional land-grant to the several States for the support of schools of scientific and industrial education. This action of the government has given rise to a considerable number of such State schools, some of which are in a flourishing condition, and excellently equipped with books and scientific material, though in others the progress has been far from satisfactory. In addition to these endowed schools a considerable list might be made of unendowed polytechnic institutions, in many of which the instruction is of the most thorough character and the equipment and professional ability equal to that of similar institutions in Europe.

The scientific schools of America, indeed, have elicited favorable comment from foreign authorities. Dr. Kerr, a Senior Inspector of the Schools of Great Britain, remarked in 1883 that America had (at St. Louis) the finest scientific school in the world. Mr. Mather, another high authority, says of the technical schools of the United States: "I am of opinion that there is nothing better of the kind in Europe. The advantage of the training in these is its practicalness."

Yet the schools founded by the land-grant of 1862 have not, as a rule, realized the expectations entertained of their work. Complaint is made that their instruction is too theoretical, that many of them suffer from a lack of scientific equipment, and that instruction in agriculture and the arts has languished through various causes. These difficulties are gradually being removed; several of these schools are equipped for thorough instruction in pure and applied science, while progress in this direction is being made in them all. Of the endowed schools several, such as the Columbia School of Mines, the scientific department of Harvard, of the Johns-Hopkins institution, of the University of Pennsylvania, and of several similar institutions, with other schools solely devoted to polytechnic instruction, have attained a high standing as schools of practical science, and compete successfully with the most famous scientific schools of Europe.

The following table taken from the report of the Commissioner of Education, gives the statistical position of these schools in the United States in 1886. The statistics of schools of science endowed with the national land-grant are given in the column under "With National Grant" and the statistics of other polytechnic schools under the head "Without."

	With National Grant.	Without.
Schools,	48	42
Instructors,	527	447
Students,	5882	4263
Books in libraries,	100,266	138,713
Value of grounds, buildings, etc.,	\$5,182,455	\$2,004,426
Income from funds,	405,507	129,895
Income from tuition fees,	174,099	74,558
Income from State appropriations,	383,390	444,305
Total income,	\$962,996	\$648,758

In recent years a system of technical instruction of a less advanced grade has been established in several States, and is meeting with highly encouraging success. The experiment of combining manual work with education is now going on in many of our cities, and the idea is spreading with great rapidity. The Manual Training School as a practical institution originated in 1868, in the Imperial Technical School of Moscow, Russia. It was not till 1876 that the world became generally aware of the excellent work that Russia was doing in this direction. In that year a display of the work of the Moscow school made at the Centennial Exposition, Philadelphia, attracted the attention of educators generally. The first to accept the new idea practically was Dr. John D. Runkle, of the Massachusetts Institute of Technology, who immediately recommended the adoption of the Russian system, and added to the Institute a department of mechanic arts. In 1877 the Washington University of St. Louis experimented in the same direction, and gained a fully endowed manual training department by 1879.

Since that time manual training departments have been added to several of the State agricultural colleges, to Girard College, Philadelphia, and to other institutions, while manual training has been made a part of the public school system in Boston, Baltimore, San Francisco, Philadelphia, Washington, and several other cities. One of the most notable of the earlier schools of this character is the Workingmen's School and Free Kindergarten, established by Felix Adler in connection with the Society for Ethical Culture of New York. The purpose of this school is to connect general training in industrial principles with moral and

educational training. The work of the manual training schools gives high satisfaction wherever instituted, and the training of the hand and the mind together promises to become in the future an essential feature of educational systems. It is now clearly perceived that the training of the hand does not detract from intellectual education, but rather brightens than dulls the wits, while the instruction of girls in sewing, cooking, and the like, and of boys in the use of tools and in the general principles of the mechanical arts, cannot but be productive of good results, in fitting the growing generation to be practically self-supporting members of the community. The time required for manual training will detract but little from that requisite for mental training, and will be particularly well applied in the case of that large percentage of the school population who lack capacity for advanced intellectual education. (See also DESIGN, SCHOOLS OF.) (C. M.)

POMEROY, a city of Ohio, county-seat of Meigs co., is on the Ohio River, 66 miles below Parkersburg, and is enclosed landward by precipitous hills. It has 2 national banks, 9 churches, a high-school, and a weekly newspaper. Its chief industries are coal-mining and salt manufacture. There are also iron-foundries, flour-mills, and a woollen-factory. The city was incorporated in 1868 and the population in 1880 was 5560, having decreased since 1870.

POMEROY, JOHN NORTON (1828-1885), legal writer, was born at Rochester, N. Y., April 12, 1828. He graduated at Hamilton College in 1847, was admitted to the bar at Rochester in 1851, and practised there for some years. In 1864 he was made professor of law in the University of New York, but in 1869 returned to the practice of his profession at Rochester. He was also active as a contributor to legal and political periodicals. In 1878 he was made professor of law in the University of California. He died at San Francisco, Feb. 15, 1885. He published an *Introduction to Municipal Law* (1865); *Introduction to Constitutional Law* (1868); *Remedies and Remedial Rights* (1876); *Equity Jurisprudence* (1883); and *Riparian Rights* (1884).

POMEROY, SETH (1705-1777), soldier, was born at Northampton, Mass., in 1705. He served in the expedition against Lewisburg in 1745 with the rank of major. In September, 1755, he succeeded to the command of a regiment in the battle of Lake George. He was a delegate to the provincial congress of Massachusetts in 1774 and was appointed by it a brigadier-general in 1775. He ventured into the fight at Bunker Hill as a volunteer and was conspicuous for his bravery. The Continental Congress had appointed him senior brigadier, but finding his competency questioned he retired from the camp without receiving the commission. In the autumn of 1776 he led a body of militia to the aid of Washington on the Hudson. He died at Peekskill, N. Y., in the following February.

PONCAS, a tribe of American Indians of the Dakota family, were found by Lewis and Clarke in 1803 dwelling on the Ponca River, west of the Missouri. They had formerly dwelt on a branch of the Red River of the North, but had been driven out by the Sioux, who are of the same family. Their numbers were then stated at 200, but this is evidently too small, for in a census made by Gen. Porter in 1829 they were set down at 600. Their first treaty with the U. S. government was in 1817, and another was made in 1825. No further notice was taken of them for thirty years. In 1858, after having been harassed by the Sioux and the whites, they sold most of their lands to the government, and were promised aid in cultivating a reservation on the Niobrara River. The buffalo, which had once been their chief food, was now driven to a distance, and they depended almost entirely on agriculture. Being without arms they were not able to protect themselves against those who took advantage of their feeble condition. They remained loyal and peaceable throughout the civil war, though the

soldiers at times committed outrages and the government did not give them aid or protection. By a new treaty in 1865 their reservation was extended, and promise was made of indemnity for their losses. Under Pres. Grant's administration they were assigned to the care of the Protestant Episcopal Church. A chapel was built and three schools established, and they seemed for a short time to prosper. Then a flood in the Missouri in 1873 caused great damage, their crops were destroyed by drought and locusts, and they were reduced to a deplorable condition. In 1876 efforts were made to remove them to Indian Territory. Their chiefs who had gone to look at the new land returned dissatisfied. But the work of removal went on. The tribe was conducted by troops, and suffered greatly on the road. In a few months one-third of their number had died. In 1877 Standing Bear, a chief, with thirty others, returned to Kansas and sought refuge among the Omahas. They were seized and imprisoned. But this act caused great excitement in Omaha, and T. H. Tibbles, editor of a newspaper, sought their release in the U. S. Court by *habeas corpus*. Judge Dundy gave a decision in favor of the Indians, allowing them to go where they pleased. Roused by this revelation of their rights under the law they soon sought to obtain restoration of their original lands in Dakota, which had been given to the Sioux. An agitation in their behalf sprang up throughout the country. In the meantime Standing Bear and others settled on an island in the Niobrara River, and soon 130 Poncas were gathered around him. Assisted by friends in Omaha they set to work industriously in improving the soil. In 1887 they were reported as numbering 210, and, receiving instruction from a missionary of the American Missionary Association, about 40 wear citizens' dress. Over 400 Poncas remained in Indian Territory and received aid from the government. They have a reservation of 101,894 acres about 30 miles south of the Kansas line. In 1887 their number was reported as 528, which was a decrease of 23 from that of the previous year. Through the influence of their chiefs they stubbornly resist attempts to civilize them, but have been prevailed upon to forego the annual sun-dance. About 100 wear citizens' dress wholly or in part. The agency school had an average attendance of 77. In 1884 the issue of rations to them was discontinued, but in 1887 a failure of crops caused it to be renewed.

PONCE DE LEON (1460-1521), the discoverer of Florida, was born in Leon, Spain, about 1460. After displaying great bravery in the wars with the Moors of Granada, he was attracted by the discovery of the New World, and in 1493 joined the second expedition of Columbus. He was placed in command of the eastern province of Hispaniola and thence conducted successful expeditions against Porto Rico. He finally subdued this island in 1509 and became its governor, but the family of Columbus caused his removal from the post. Having amassed great wealth he immediately organized an expedition for the discovery of a "Fountain of Youth," of which reports were current among the natives. On March 3, 1513, he sailed from Porto Rico with three ships and cruised among the Bahamas. On March 27, being Easter Sunday, called by the Spaniards *Pascua Florida*, he sighted land, which he named Florida. On account of bad weather he did not go on shore until April 9, when, near the mouth of the River St. John, he formally took possession in the name of the King of Spain. He cruised southward along the coast and among the Tortugas, and then returned to Porto Rico. On reporting his discovery in Spain he was made governor of Florida, and in 1521 he attempted to effect its colonization, but he was repulsed and wounded by the natives and withdrew to Cuba, where he soon died of the effects of his wound.

POND, ENOCH (1791-1882), Congregationalist minister, was born at Wrentham, Mass., July 29, 1791. He graduated at Brown University in 1813, and studied

theology with Rev. Dr. Emmons. He was ordained pastor of the Congregational Church, Auburn, Mass., in 1815, and in 1828 became editor of *The Spirit of the Pilgrims*, a monthly founded at Boston to uphold Orthodox theology against the Unitarian movement. In 1832 he was made professor of theology in the seminary at Bangor, and here he remained until his death. In 1836 he had been made president of the seminary and professor of ecclesiastical history, but at the age of eighty was made professor emeritus. He published *Lives of President Samuel Davies* (1827), Count Zinzendorf (1839), John Wickliffe (1841), the Mather Family (1844), Sir William Phipps (1847), John Knox (1856). His other works include *Plato* (1846); *The Ancient Church* (1851); *Svedenborgianism Examined* (1861); *Pastoral Theology* (1866); *Christian Theology* (1868); *History of God's Church* (1871).

PONTE, LORENZO DA (1749-1838), an Italian poet, was born at Ceneda, Venice, March 10, 1749. He was professor of rhetoric, but was banished from Venice on account of his liberal opinions and especially a satirical poem. He then became Latin secretary to Emperor Joseph II., and wrote the librettos of several operas, among which were *Don Giovanni* and the *Marriage of Figaro*. He went to London as secretary of an opera company, and in 1805 removed to New York. Here he gave instruction in Italian, and at the age of eighty was made professor of that language in Columbia College. He published an autobiography (New York, 1823), and died Aug. 17, 1838. His son, Lorenzo L. Da Ponte (1805-1840), was professor in the University of the City of New York, and published a *History of the Florentine Republic* (1833).

PONTIAC (d. 1769), a noted Indian warrior, belonged to the Ottawa tribe, and was born about 1710. His first exploit after becoming principal chief of his tribe was the defence of Detroit on behalf of the French in 1746. He is also said to have led his warriors at Braddock's defeat in 1755. His hatred of the English increased after they had come into possession of Canada, and he proceeded to organize a conspiracy among the Indian tribes to exterminate the colonists. The month of May, 1763, was appointed for a universal attack on the settlements. In nine cases the attacks were successful, but at Detroit, where Pontiac led in person, the settlers were forewarned. He then conducted a regular siege for five months, and meantime sought aid from the French in Louisiana. He also obtained food for the besiegers by issuing a kind of notes on birch-bark, signed with the figure of an otter. Though the siege was raised Oct. 12, he faithfully redeemed the notes. But he was unable to retain his followers and eventually himself submitted to the English in 1766. In his later years he was intemperate, and he was killed by an Indian at Cahokia, opposite St. Louis, in 1769. The best history is F. Parkman's *Conspiracy of Pontiac* (1851). F. B. Hough edited a *Diary of the Siege of Detroit* (1860).

POOLE, STANLEY LANE, English author and Orientalist, was born in London Dec. 18, 1854. He is a grandnephew of E. W. Lane, the noted Orientalist, by whom he was partly educated. He then proceeded to Corpus Christi College, Oxford, whence he graduated in 1878. He had already given attention to numismatics under his uncle's direction, and in 1874 he was appointed by the trustees of the British Museum to write the official *Catalogue of Oriental Coins* (8 vols., 1875-83). To this was added a *Catalogue of Indian Coins* (2 vols., 1885). He also completed his great-uncle's *Arabic Lexicon*, editing the sixth and seventh volumes (1877-85), and published a *Life of E. W. Lane* (1877). As the result of a mission to Egypt in 1883 he published *Art of the Saracens* (1886), and has since visited Russia in numismatic investigation. He contributed many articles to the ninth edition of the *Encyclopædia Britannica*, to the *Dictionary of National Biography*, and various periodicals. Among his works are *Essays in Oriental Numismatics* (2 series, 1872-77);

Egypt (1881); *Speeches and Table-Talk of Mohammed* (1882); *Social Life in Egypt* (1883); *Life of Gen. F. R. Chesney* (1885); *Coins and Medals* (1885); *History of the Moors in Spain* (1886).

His uncle, REGINALD STUART POOLE, born in London Feb. 27, 1832, is also distinguished as an Egyptologist and numismatist. He has been connected with the British Museum since 1852, holding the positions of assistant in the department of antiquities, assistant keeper of coins and medals (1861), and keeper (1870). He has edited *Official Catalogue of Greek, Roman, Oriental, and English Coins* (19 vols., 1873-85). He has also published *Howe Egyptiaca* (1851); *Cities of Egypt* (1882); *Coins of the Ptolemies* (1883); *Coins of the Shaks of Persia* (1886). He has contributed to the *Encyclopædia Britannica* and to periodicals.

POOR, ENOCH (1736-1780), Revolutionary general, was born in 1736 at Andover, Mass., being descended from Daniel Poor, one of its first settlers. He engaged in mercantile business at Exeter, N. H., and in 1775 was appointed colonel. He served at the siege of Boston, then went to New York, and was sent to take part in the invasion of Canada. In February, 1777, he was appointed brigadier-general, and as such was engaged in resisting Burgoyne's invasion. He afterwards served under Washington, spent the winter at Valley Forge, fought at Monmouth in 1778, and was in Sullivan's expedition against the Indians of Western New York in 1779. In the next year he had command of a brigade of light infantry under Lafayette. He was killed in a duel with a French officer near Hackensack, N. J., Sept. 8, 1780.

POORE, BENJAMIN PERLEY (1820-1887), journalist, was born at Newburyport, Mass., Nov. 2, 1820. He was descended from John Poore, who came from England in 1635, and purchased from the Indians in 1650 Indian Hill in Newbury, on which Ben resided most of his life. He was educated at Dummer Academy, learned the printer's trade, and went to Athens, Ga., where he edited the *Southern Whig* from 1838 to 1840. He was then made agent of the State of Massachusetts to obtain in Europe historical documents and was connected with the U. S. legation to Belgium. After travelling over Europe and as far as Egypt and Palestine he returned in 1847 and became Washington correspondent of the Boston *Atlas* and afterwards of other papers. He introduced the practice of reporting the Washington news by telegraph. He was clerk of the Senate committee on foreign affairs, and clerk of the printing committee for 20 years. He died at Washington, D. C., May 30, 1887. He compiled by order of Congress several works, among which were *Our Diplomatic Relations, Federal and State Constitutions, Colonial Charters, Catalogue of Government Publications*. He issued annually the *Congressional Directory*. He published *Lives of Generals Zachary Taylor, Grant, Logan, and Burnside*. His last work was *Perley's Reminiscences* (2 vols., 1886). He was prominent in the Masonic fraternity, having taken the 33d degree, and contributed to this work the article on FREE MASONRY.

POPE, JOHN, major-general, was born at Kaskaskia, Ill., March 12, 1823, being the son of Judge Nathaniel Pope (1785-1850). He graduated at West Point in 1842, and entered the topographical engineers. He served under Gen. Taylor in the Mexican war and won two brevets for gallantry. From 1849 to 1859 he was engaged in exploring expeditions in Minnesota, New Mexico, Texas, and among the Rocky Mountains. He was afterwards engaged in light-house duty. His intense loyalty to the Union induced him to use such remarks on Pres. Buchanan's policy in reference to the United States forts in the South that he was summoned before a court-martial, but the trial was not pressed. Capt. Pope was one of the officers who escorted Lincoln to Washington before his inauguration as President. In May, 1861, he was made brigadier-general and assigned to command in Missouri, where

he was successful in suppressing rebel movements. Early in 1862 he had command of the Army of the Mississippi and by his vigorous movements in March he captured New Madrid and Island No. 10 with thousands of prisoners. He was then promoted major-general of volunteers and brigadier-general in the regular army. He took command of the Army of Virginia, which consisted of all the troops in that State except those under McClellan near Richmond. Unfortunately he inaugurated his command with boastful proclamations which set forth the achievements of the armies in the West in contrast with the want of success in the East. He left Washington on July 29 with rash pledges of victory, and a month later was completely defeated by Gen. "Stonewall" Jackson at Bull Run (see BULL RUN). He returned to Washington and soon asked to be relieved from the command. He attributed his defeat to the want of proper support by the officers who had been under Gen. McClellan's command. The controversy raged especially around the conduct of Gen. Fitz John Porter, and took a political form. Gen. Pope was sent to Minnesota and engaged in a campaign with the Sioux. After the war he commanded a military district in the South and later had command of the Department of the Missouri. In October, 1882, he was made major-general in the regular army. He published *Explorations from the Red River to the Rio Grande and Campaign in Virginia* (1863).

PORCIER, FRANCIS PEYRE, physician and botanist, was born at St. John's Berkeley, S. C., Dec. 14, 1825. He is of Huguenot descent, graduated at South Carolina College in 1844, then studied medicine, and received his degree from Charleston Medical College in 1847. He lectured on medical subjects at Charleston and edited the *Charleston Medical Journal*. During the civil war he had charge of Confederate hospitals at Norfolk and Petersburg, Va. In 1872 he was elected president of the South Carolina Medical Association. His chief publications are *Medical Botany of South Carolina* (1849); *Cryptogamic Plants of the United States* (1854); *Resources of Southern Fields and Forests* (1863).

PORGY or MENHADEN. See FISHERIES.

PORK. See SWINE.

PORTER, ANDREW (1743-1813), general, was born at Worcester, Montgomery co., Pa., Sept. 24, 1743. He was engaged as a school-teacher in Philadelphia, when Congress in 1776 appointed him a captain of marines. He was soon employed in the artillery service and fought at Trenton, Princeton, Brandywine, and Germantown. In 1779 he took part in Gen. Sullivan's expedition against the Indians of Western New York. After the war he was a commissioner to run the boundary lines of Pennsylvania (1784), was major-general of militia (1800), and surveyor-general (1809). At the outbreak of the war of 1812 Pres. Madison offered him a commission as brigadier-general, but he declined on account of his age. He died at Harrisburg, Pa., Nov. 16, 1813.

His eldest son, **DAVID R. PORTER** (1788-1867), was governor of Pennsylvania 1839-45. Charges of irregularity in his election gave occasion for what was called the "Buckshot War" in the organization of the Legislature. He died at Harrisburg, Aug. 6, 1867.

Another son, **JAMES MADISON PORTER** (1793-1862), was a member of the Pennsylvania Constitutional Convention in 1838, and was appointed secretary of war by Pres. Tyler, but rejected by the Senate. He was afterwards a State judge, and one of the founders of Lafayette College, Easton.

His nephew, **ANDREW PORTER** (1819-1872), general, was born at Lancaster, Pa., July 10, 1819. He graduated at West Point in 1837, and served in the Mexican war with distinction. At the outbreak of the civil war he was made colonel in the regular army and then brigadier-general of volunteers. He commanded a brigade of regulars at the battle of Bull

Run, and was afterwards provost-general of the Army of the Potomac. He resigned in April, 1864, and died at Paris, Jan. 4, 1872.

HORACE PORTER, son of Gov. David R. Porter, was born in Huntingdon co., Pa., April 15, 1837. He graduated at West Point in 1860 and entered the artillery. In October, 1861, he went as assistant ordnance-officer to Port Royal, S. C., and he took part in the siege of Fort Pulaski on the Savannah River. He was chief of ordnance in different armies from July, 1862, to November, 1863. In April, 1864, he was made aide-de-camp to Gen. Grant with rank of lieutenant-colonel, and continued with him till the close of the war. He then made tours of inspection in the South and on the Pacific coast until Gen. Grant became President, when he was made his military secretary. In 1873 Col. Porter resigned to take part in railroad management. He has published *West Point Life* (1866), and has contributed to various magazines.

PORTER, DAVID (1780-1843), naval-officer, was born at Boston, Feb. 1, 1780. His father, of the same name, was captain of a merchant-vessel and the son early went to sea. In April, 1798, he entered the U. S. navy as midshipman and was on board the Constitution in her fight with L'Insurgente in the West Indies. He was made lieutenant in 1799 and was wounded in an engagement with pirates at Santo Domingo. His next service was in the war with Tripoli, but after some exploits he was captured in the ship Philadelphia aground in Tripoli harbor in October, 1803. A captivity of eighteen months followed. In July, 1812, he was appointed to the command of the Essex (32 guns) and sailed on a cruise to the Pacific memorable in American annals. Among his captures was the British ship Alert (20 guns), the first man-of-war so taken. Of twelve other vessels captured some were armed by him to protect American whale-fishers. On March 28, 1814, his cruise was brought to a close in the harbor of Valparaiso, where after a desperate fight he was overpowered by a British frigate (36 guns) and a sloop (28 guns). Porter wrote to his government, "We are unfortunate, but not disgraced." David G. Farragut, then a lad of twelve, had served as midshipman in the Essex and won Porter's commendation (see FARRAGUT, in the ENCYCLOPÆDIA BRITANNICA). Capt. Porter was employed as naval-commissioner from 1815 to 1823. He then took command of an expedition against the pirates in the West Indies, but having exceeded his power in exacting an apology from the authorities at Porto Rico for an insult to the American flag, was recalled and suspended for six months. He resigned his commission in August, 1826, and was appointed commander-in-chief of the Mexican navy in the war against Spain. In 1829 he was sent as U. S. consul to Algiers, and in 1830 as chargé d'affaires to Turkey, where he was afterwards minister-resident. He died at Constantinople March 28, 1843, and his remains were afterwards interred at Philadelphia. He published a *Journal of the Cruise of the Essex* (2 vols., 1815), and from his letters was compiled *Constantinople and its Environs* (2 vols., 1835).

PORTER, DAVID DIXON, admiral, son of the preceding, was born at Philadelphia, June 8, 1814. When his father took command of the Mexican navy he was made a midshipman and was captured on the Guerrero after a severe fight. In 1829 he became a midshipman in the U. S. navy and served in various waters until 1845, when he was stationed at the Washington Observatory. In the Mexican war he served at Vera Cruz and other points. He was afterwards engaged in the coast-survey, as he has been before for four years (1836-40), and in 1849 entered on command of the Californian mail-steamers. At the outbreak of the civil war he held a commander's commission and was sent to the relief of Fort Pickens, at Pensacola. He prepared a flotilla of mortar-boats for service in the expedition against New Orleans. After

the capture of this city the flotilla was employed against Vicksburg, and Porter with the rank of rear-admiral had command of all the naval forces on the Mississippi. Steamboats covered with iron plates were used in many places for attack and for transport. Arkansas Post was captured in January, 1863, and the Grand Gulf batteries destroyed in April. Porter's efficient and generous co-operation in the siege of Vicksburg was repeatedly acknowledged by Gen. Grant. He afterwards assisted in Gen. Banks's Red River expedition in April, 1864, and in the same year was transferred to the James River. Here he had command of the naval forces which took part in the expedition against Fort Fisher (*q. v.*) and captured it Jan. 15, 1865. He was made vice-admiral in 1866 and was superintendent of the Naval Academy for two years. On the death of Farragut in 1870 Porter succeeded him as admiral of the navy. He has in recent years published several books, among which are *Life of Commodore David Porter* (1875); *Incidents and Anecdotes of the Civil War* (1885); two novels, *Allen a Dare* and *Robert le Diable* (1885); *Harry Marline* (1886); and a *History of the Navy in the War of the Rebellion* (1887).

WILLIAM DAVID PORTER (1809-1864) was another son of Commodore David Porter, born at New Orleans, March 10, 1809. Entering the navy as midshipman in 1823, he retired in 1855, having in the meantime originated the light-house system now in use. He returned to the service in 1859, commanded the iron-clad Essex on the Mississippi in 1862, and safely passed the Confederate batteries on his way to New Orleans. For his exploits he was made commodore in July, 1862, but was obliged by ill health to retire from service. He died at New York, May 1, 1864.

PORTER, FRIZ JOHN, general, was born at Portsmouth, N. H., June 13, 1822, being a nephew of Commodore David Porter. He graduated at West Point in 1845, entered the artillery and served with distinction in the Mexican war under Gen. Scott from Vera Cruz to the capture of the City of Mexico, where he was wounded Sept. 13, 1847. He was afterwards instructor of artillery and cavalry at West Point and in 1856 was transferred to the adjutant-general's department. He served in the Utah expedition in 1858. At the outbreak of the civil war he was made colonel in the regular army and soon after brigadier-general of volunteers. He was chief of staff to Gen. Robert Patterson and to Gen. N. P. Banks until August, 1861, when he had command of a division in the defenses of Washington. In Gen. McClellan's Peninsular campaign Porter had direction of the siege of Yorktown, afterwards commanded the fifth corps of the Army of the Potomac. His gallantry was displayed at Mechanicsville, Gaines's Mill and Malvern Hill. After the failure of the attack on Richmond Fitz John Porter's corps was transferred to the Army of Virginia under Gen. Pope. At the second battle of Bull Run, Aug. 29, 1862, he was ordered to attack Gen. Jackson's flank, but did not move on account of the presence of Gen. Longstreet in front. Gen. Pope afterwards attributed his defeat to Gen. Porter's inactivity and even charged him with treachery. McClellan returned to the chief command and Fitz John Porter fought under him at Antietam, but on November 27 he was tried by court-martial on a charge of disobedience of orders, and on Jan. 21, 1863, he was cashiered. After many efforts to obtain a rehearing of his case, a board of inquiry was called by Pres. Hayes in April, 1878, which eventually declared Gen. Porter free from blame. Pres. Arthur in May, 1882, remitted part of his sentence, but vetoed a bill passed by Congress for his relief, on account of its unjust effect on other officers. In 1885 a bill free from this objection was passed and signed by Pres. Cleveland, and on Aug. 7, 1886, Gen. Porter was restored to the army with the rank of colonel. Gen. Porter had in the meantime been engaged in business in New York city, and was superintendent of the New

Jersey insane asylum. In 1875 he was appointed commissioner of public works in New York city. From 1884 to 1888 he was police commissioner. Gen. Grant, while President, had refused to reopen Gen. Porter's case, but afterwards became convinced of his innocence and published an article to that effect in the *North American Review* (Dec., 1882). (See BULL RUN.)

PORTER, JOSIAS LESLIE, educator and author, was born Oct. 4, 1823, at Burt, County Donegal, Ireland. He graduated at the University of Glasgow in 1842, and studied theology at the University of Edinburgh and the Free Church College. In 1846 he was ordained in the Presbyterian Church of England and had charge of a church at Newcastle. In 1849 he was sent by the Irish Presbyterian Church as a missionary to Damascus and resided there until 1859. He travelled extensively in Palestine, Arabia, Egypt, and Northern Africa. On his return to Ireland he was made professor of Biblical criticism in the Assembly's College, Belfast. Dr. Porter was moderator of the General Assembly in 1875. He took an active part in organizing the new system of higher education in Ireland, and, in 1878, was appointed by Parliament commissioner of intermediate education. In the next year he was made president of Queen's College, Belfast, and in 1880 senator of the Royal University of Ireland. He has published *Five Years in Damascus* (2 vols., 1855); *Murray's Handbook for Syria and Palestine* (1858); *The Pentateuch and the Gospels* (1864); *Giant Cities of Bashan* (1865); *Jerusalem, Bethany and Bethlehem* (1886.). He married in 1849 the youngest daughter of Rev. Dr. Henry Cooke (*q. v.*), and he has published *Life and Times of Dr. Cooke* (1871.) He has contributed to various reviews, magazines, and encyclopedias, chiefly on subjects relating to Biblical geography and history.

PORTER, NOAH, philosopher and educator, was born at Farmington, Conn., Dec. 14, 1811. His father, Rev. Dr. Noah Porter (1781-1866), was minister of that parish for fifty-five years. He graduated at Yale College in 1831, and engaged in teaching. In 1833 while tutor at Yale College he studied theology, and in April, 1836, was ordained pastor of the Congregational church at New Milford, Conn. In 1843 he accepted a call to Springfield, Mass., and in 1846 he was chosen professor of metaphysics and moral philosophy at Yale College. He became president of the college on the resignation of Rev. Dr. Woolsey in 1871, and after a successful career of fifteen years himself resigned in 1886. He has contributed to several leading reviews and has published *The Human Intellect* (1868); *Books and Reading* (1870); *American Colleges and the American Public* (1870); *Elements of Intellectual Philosophy* (1871); *The Science of Nature versus the Science of Man* (1871); *Evangeline* (1882); *Elements of Moral Science* (1885); *Bishop Berkeley* (1885); *Kant's Ethics* (1886). Dr. Porter was the chief editor of the revised editions of *Webster's Dictionary*, 1864 and 1880.

PORTER, PETER BUEL (1773-1844), general, was born at Salisbury, Conn., Aug. 14, 1773. His father, Dr. Joshua Porter (1730-1825), superintended the manufacture of cannon for use in the American army during the Revolution and fought at Saratoga. Peter graduated at Yale in 1791, studied law at Litchfield, and settled in Western New York, where he had large estates. He was elected to Congress in 1808 and he was active in the measures leading to a declaration of war against Great Britain in 1812. He then resigned to become quartermaster-general of New York and afterwards had command of volunteers who drove out the British invaders. In 1814 he led a brigade into Canada under Gen. Brown and fought at Chippewa and Lundy's Lane. On Sept. 17, while besieged at Fort Erie, he made a sortie which compelled the enemy to depart. His services were acknowledged by Congress with a gold medal and by New York State with a sword. In 1816 he was employed as commissioner

in settling the boundary between Canada and the United States. He was afterwards secretary of state of New York, and was secretary of war in the administration of Pres. John Quincy Adams. He was prominent in the progress of Western New York and was one of the projectors of the Erie Canal. He died at Niagara Falls, March 20, 1844.

His only son, PETER AUGUSTUS PORTER (1827-1864), graduated at Harvard College in 1845, studied in Germany, and was elected to the Legislature of New York in 1861. He raised a regiment for service in the civil war and was killed at Cold Harbor, June 3, 1864.

PORT HURON, a city of Michigan, the county-seat of St. Clair co., is on the St. Clair River, at the mouth of the Black River, and at the foot of Lake Huron, 62 miles N. N. E. of Detroit. It is the terminus of three railroads, the Grand Trunk, the Chicago and Grand Trunk, and the Port Huron and North-western. There are 4 iron bridges over the rivers, 2 of which are railroad bridges, and a railroad tunnel is now being built under St. Clair River to Sarnia on the Canadian side. With this town there is steam-ferry communication and steamboats also ply to Detroit daily while navigation is open. Port Huron has a fine building for the U. S. custom-house and post-office, erected in 1877, a city-hall, 1 national and 3 other banks, an opera-house, 1 daily and 4 weekly newspapers, 9 churches, and 7 schools with substantial buildings. Timber is brought in large quantities by the Black River and manufactured and shipped here. There are several saw-mills, ship-yards, dry-docks, grain-elevators, machine- and boiler-shops, threshing-machine-works, and extensive car-works and railroad repair-shops. In the vicinity large quantities of salt are produced and natural gas and some petroleum are obtained. The city is supplied with water from Lake Huron by the Holly system. It has three small parks. The valuation of property is \$5,000,000, its public debt is \$150,000, and its yearly expenses about \$100,000. Originally settled by Canadian French in 1819, it was incorporated as a city in 1857. Its population in 1880 was 8883.

PORT JERVIS, an incorporated town of Orange co., N. Y., is on the Delaware River above the mouth of the Neversink River, 88 miles N. W. of New York city, on the Erie Railroad and on the Port Jervis, Monticello, and New York Railroad. It is close to the border of New Jersey and a bridge connects it with Pike co., Pa. It has 2 national banks, 7 schools, 2 daily and 3 weekly newspapers, 2 foundries, the Erie Railroad machine-shops, planing-, saw-, and feed-mills, 2 glass-works, boot-and-shoe-factory, glove-works, and watch-case-factory. The village was settled in 1826 and incorporated in 1853. It has a park and water-works and is lighted with gas and electric light. It is free of debt and its public yearly expenses are about \$20,000. Population in 1880 was 8678.

PORTLAND, a city of Maine, seat of Cumberland co., is in 43° 40' N. lat. and 70° 14' W. long., on a peninsula of 1666 acres in Casco Bay. It is 62 miles S. S. W. of Augusta, capital of the State. Besides the facilities for commerce furnished by its deep and capacious harbor, it has five railroads, the Grand Trunk, Maine Central, Boston and Maine, Portland and Ogdensburg, and Portland and Rochester. The important buildings include the custom-house, post-office, city-hall, court-house, observatory, Baxter Hall, Mechanics' Hall, Maine general hospital, public library, The Society of Natural History and the Society of Art have valuable collections. Besides 6 national banks there are 8 others. There are 15 hotels, 4 daily and 11 weekly newspapers, and 26 schools. There are 32 churches, several of which have fine edifices. The industrial works comprise rolling-mills, stove-foundries, locomotive- and boiler-works, sugar-refineries, shoe-factories, carriage-works. Rising gradually from the harbor and well shaded Portland presents a very picturesque appearance. It has gas and electric light, water-works, and a park called "The Oaks." Its pop-

erty is assessed at \$33,752,040 in 1888; its public debt is \$3,440,000, and the city expenses for 1887 exceeded \$936,000. The first settlement was made here in 1633, and it was included in the town of Falmouth, which was incorporated in 1650. Portland was burnt by Indians in 1676, by French and Indians in 1690, by the British in 1775. It was incorporated in 1786 and received a city charter in 1832, having on its seal the motto "Resurgam." In 1866 it again suffered from a disastrous conflagration. Its population in 1880 was 33,810.

PORTLAND, the largest city of Oregon, county-seat of Multnomah co., is on the Willamette River, 12 miles from its confluence with the Columbia and about 120 miles from the ocean, yet it is virtually a seaport to which large vessels come from various parts of the world. It is in 45° 30' N. lat. and 122° 27' 30" W. long. It has a fine court-house, a U. S. government building, 10 banks, several large hotels, 3 public halls, a theatre, a high-school, good public schools, a female academy, a large library, asylum for the insane, and 25 churches. The industrial works comprise iron-foundries, machine-shops, flour-mills, saw-mills, canneries, breweries, furniture-factories, shoe-factories, etc. There are 5 daily and 15 weekly newspapers and 2 monthly magazines published here. Lumber, wheat, flour, and wool are largely exported. Portland is a handsome city, with wide, well-shaded streets, and has four lines of street railway. It has gas- and water-works. It is the terminus of the Oregon Railway and Navigation Company's system. It was settled in 1845, became a city in 1851, and in 1880 had a population of 17,577. Its present population exceeds 40,000.

PORTSMOUTH, a city of New Hampshire, half-shire-town of Rockingham co., is on the Piscataqua River, 3 miles from the Atlantic Ocean, and 54 miles N. N. E. of Boston. It is built on the slope of a peninsula, overlooking a deep, capacious harbor with rock bottom. The streets are well shaded and there are many antique mansions. Portsmouth has a custom-house, an athenæum, with a library of 10,000 volumes, a music-hall, 4 national banks, 2 savings banks, and 11 churches, some of which have fine structures. Three daily and three weekly newspapers are published here. The manufactures include cotton and woollen goods, hosiery, shoes, iron-castings, etc. Ship-building is still carried on, but the commerce has declined. The U. S. navy-yard of Kittery, on an island opposite, has 3 large ship-houses and a floating balance-dock, 350 feet long by 105 wide, with 24 pumps. Portsmouth was settled in 1623, but did not receive a city charter until 1849. It was the capital of New Hampshire until 1807. It is now a favorite summer-resort. Its population in 1880 was 9690.

PORTSMOUTH, a city of Ohio, seat of Scioto co., is on the Ohio River, at the mouth of the Scioto, 113 miles E. S. E. of Cincinnati. It is on the Scioto Valley, the Ohio and North-western, and the Cincinnati, Washington, and Baltimore Railroads. It has a court-house, 2 opera-houses, 3 national banks, and 1 other bank, 1 daily, 5 weekly, and 2 monthly newspapers, 21 churches, 6 public schools, and a young ladies' seminary. The industrial works comprise 2 rolling-mills, 3 foundries, 2 woollen-mills, 2 stone-mills, 3 saw-mills, steel-spring-works, a tannery, wheelbarrow, furniture, and shoe-factories. Iron is abundant in the vicinity. Portsmouth has gas and electric light, a paid fire department, a street railway, a Holly system of water-works. The city is partly enclosed by hills and on the opposite side of the Ohio there are hills 500 feet high. Population in 1880 was 11,321.

PORTSMOUTH, a city of Virginia, county-seat of Norfolk co., is on the west bank of the Elizabeth River, opposite Norfolk. It has a fine harbor, the river here being about two-thirds of a mile wide. In the suburb of Gosport is a U. S. navy-yard with a granite dry-dock and a marine-hospital. The navy-yard was destroyed at the beginning of the civil war, to prevent its

stores from falling into the hands of the Confederates, but has since been restored. Portsmouth has 2 banks, 15 churches, 2 daily and 3 weekly newspapers, good public and private schools. It exports lumber, naval stores, cotton, and iron. Early vegetables are extensively shipped to Northern cities. Portsmouth in 1880 had 14,870 inhabitants.

POST. TRUMAN MARCELLUS (1810-1886), clergyman, was born at Middlebury, Vt., June 3, 1810. He graduated at the college of that town in 1829 and while studying law was tutor there. In 1832 he went to Washington and thence to St. Louis, and settled at Jacksonville, Ill., where he was made professor of languages in Illinois College, and also in 1840 ordained pastor of the Congregational Church. In 1847 he was called to the pastorate of the Third Presbyterian Church of St. Louis, and in 1851 he formed the First Congregational Church there. He exerted great influence and was the prominent representative of New England views in the theology, education, and public affairs. Besides attending to his pastoral duties he was professor of history in Washington University, St. Louis, professor of ecclesiastical history in Chicago Theological Seminary, and delivered some lectures in Andover Theological Seminary. He died Dec. 31, 1886. He published *The Skeptical Era in Modern History* (1856) and contributed to the *Andover Review* and other periodicals.

POSTAL SERVICE OF THE UNITED STATES.

See Vol. XIX. Probably the first attempt to establish postal service within any part of the territory now embraced in the United States was made by the General Court

of Massachusetts in 1639—just nineteen years after the landing of the Pilgrims, and only four years after the proclamation of the Crown establishing a general postal system in England. On the records of the court for that year we find the following entry: "It is ordered that notice be given that Richard Fairbanks his house in Boston is the place appointed for all letters which are brought from beyond the seas, or are to be sent thither to be left with him; and he is to take care that they are to be delivered or sent according to the direction. And he is allowed for every letter a penny, and must answer all miscarriages through his own neglect in this kind." This service was in a short time expanded into one for the transmission and delivery of letters other than those for or from foreign parts; though its administration did not give universal satisfaction; for on the records of the General Court in 1667 is a petition of citizens of the colony for "better arrangements for the sending and receipt of mails"—the petition alleging a number of grievances, one among them being the frequent loss of letters.

In 1657 mail service existed also in the colony of Virginia, but of a very primitive character. By act of Assembly March 13, 1657, it was provided "that all letters superscribed for the public service shall be immediately conveyed from plantation to plantation to the place and person directed, under a penalty of one hoghead of tobacco for each default." Although this system was intended solely for the transmission of letters on official business, it is not unreasonable to assume that private letters were by general consent at times transmitted in the same way; but of course this could not have accommodated the growing demands of the Colony, and so we find that later on, in 1692, an act of Assembly was passed providing for the "erection and establishment" of a post-office, as a matter of "general concernment and of great advantage for the increase and preservation of trade and commerce."

In 1672 the government of the colony of New York established a "post to goe monthly from New York to Boston;" and notice was given to "those that be disposed to send letters, to bring them to the secretary's office, where in a lockt box they shall be preserved till the messenger calls for them, all persons paying the post before the bagg bee sealed up." This monthly dispatch was evidently for a long time sufficient

for the wants of the public. Thirty years later it was changed to a fortnightly one, as appears from the following notice published in the *Boston News Letter*: "By order of the Postmaster-General of North America: These are to give notice that on Monday night, the 6th of December (1702), the western post between Boston and New York sets out once a fortnight the three winter months of December, January, and February, and to go alternately, from Boston to Saybrook and Hartford, to exchange the mayl of letters with the New York ryder; and all persons that sends letters from Boston to Connecticut after the 13th inst. are hereby notified first to pay the postage on the same."

In Pennsylvania the first record of any postal service is to be found in a law of the provincial Assembly passed in 1683, which required that "every justice of the peace, sheriff, or constable within the respective counties of this province and territories thereof, to whose hands or knowledge any letter or letters shall come directed to or from the governor, shall dispatch them three hours at the furthest after the receipt or knowledge thereof, to the next sheriff or constable, and so forwards as the letters direct, upon the penalty of twenty shillings for every hour's delay." This, like the law of Virginia, was intended for public letters only; but in 1693 the General Assembly of the province passed a "law for erecting a post-office," whereby authority was given to Andrew Hamilton to establish a "general post-office at Philadelphia, from whence all letters and packets may be with all expedition sent into any of the parts of New England and other the adjacent colonies in these parts of America, at which said office all returns and answers may be received."

In Maryland and the two Carolinas there does not appear to have been any postal service whatever until very much later than the foregoing dates. Even as late as about 1755, postal communication between points south of Philadelphia was without any regularity, as is seen in the following passage from Dr. Wm. Douglass's *Historical and Political Summary of British Settlements in North America* (1755): "From Piscataqua or Portsmouth to Philadelphia is a regular postage; from thence to Williamsburg is uncertain, because the post does not proceed until letters are lodged sufficient to pay the charge of the post-riders. From Williamsburg, in Virginia, to Charlestown, in South Carolina, the post-carriage is still more uncertain."

In 1692 the postal service of the colonies was, by authority of the government of Great Britain, placed in charge of an officer of the Crown called the Deputy Postmaster-General for America; but practically each colony exercised the right to govern the service within its own territory, and to fix its own schedule of postages; and this state of things continued until 1710, when by formal act of Parliament (9 Queen Anne, chap. 10) the first organized system for the transmission of the mails in the colonies was created. By this act the Postmaster-General was required "to keep his chief office in New York, and other chief offices in some convenient place or places in other of her Majesty's provinces or colonies in America;" a monopoly was established, not only in the carriage of letters, but of parcels of goods and the transport of travellers; and a fixed tariff of charges therefor was prescribed. The following were the rates for letters and parcels fixed by this act, which were without material modification renewed by the act of 1765 (5 Geo. III., chap. xxv.):

All letters and packets from London to New York, in North America (or vice versa), single, 1s.; double, 2s.; treble, 3s.; one ounce in weight, 4s. From any part of the West Indies to New York, single, 4d.; double, 8d.; treble, 1s.; ounce, 1s. 4d.
From New York to any place within 60 English miles thereof, or thence back to New York, single, 4d.; double, 8d.; treble, 1s.; ounce, 1s. 4d.; over 60 and not over 100 miles, single, 6d., etc.

From New York to Perth Amboy, "the chief town in East New Jersey," the single rate was 6d., as it was to "Bridlington, the chief town in West New Jersey;" to New London, "the chief town in Connecticut," and to Philadelphia, it was 9d.; ounce, 3s.; to Newport, Boston, Portsmouth, and Annapolis, "the chief town in Maryland," it was 1s.; ounce, 4s.; to Williamsburg, "the chief town in Virginia," it was 1s. 3d.; ounce, 5s.; and to Charleston, S. C., it was 1s. 6d.; ounce, 6s.

The system thus begun in 1710 was not successfully managed; it yielded no revenue to the government. and, as we have seen above, in some parts of the country it furnished scarcely any mail service whatever. Even near Philadelphia, then the most populous city in the colonies, the meagreness of the mails is calculated at this day to excite a smile; for example, it was customary, down to 1750, for letters intended for persons residing in Newtown, Bristol, and Chester, in Pennsylvania, and even in Newcastle, Delaware, to remain in the Philadelphia post-office until called for. Bristol was 20 miles from Philadelphia in one direction, and Newcastle 40 miles in an opposite direction, making a distance of 60 miles with but one post-office. In 1753, however, on the death of the Deputy Postmaster-General for America, the celebrated Benjamin Franklin—who had been postmaster at Philadelphia for sixteen years—succeeded to the office by a commission from the Postmaster-General of England. He was to have for himself and an associate £600 per annum, to be made out of the profits of the service; and to do this many improvements were undertaken. For example, in the year of his appointment a penny-post, for the delivery of letters to the residences of addressees of the mail, was established at Philadelphia; in the following year a tri-weekly mail between Philadelphia and New York, in spring, summer, and fall, was established; in the next year (1755) notice was given that to assist trade, arrangements had been made by which the winter mail from Philadelphia to New England, which before had set out but once a fortnight, would thereafter set out once a week, as in summer; in 1756 the first stage probably that was started in the colonies, began to carry the mails between Philadelphia and New York; in 1758 newspapers, which previously had been carried in the mails free, were charged with postage. Other reforms and improvements, far in advance of anything before attempted, were begun, so that in 1774, the last of Franklin's administration under the Crown, the net revenue of the postal service was over £3000. On January 30 of that year this great man was removed from office, as he himself calls it, "by a freak of the ministers," due to his pronounced advocacy of the cause of the colonies in the troubles with the mother country just then near their culmination; and from then until the middle of the following year, when the Second Congress of the colonies took upon itself the management of public affairs, the postal establishment was almost without control.

On July 26, 1775, nearly a year before the Declaration of Independence, a resolution was passed by the Continental Congress creating a post-office department with head-quarters at Philadelphia, continuing the rates of postage then in force, appointing Benjamin Franklin Postmaster-General at a salary of \$1000 a year, and giving him authority to appoint an assistant and comptroller of accounts, and as many postmasters as to him might seem proper—their salaries in no case to exceed 20 per cent. of the gross receipts of the post-office. On Nov. 7, 1776, Dr. Franklin being then in France engaged in business of a diplomatic character, his son-in-law, Richard Bache, was appointed Postmaster-General by Congress, and he remained in office until Jan. 23, 1782, when Ebenezer Hazard succeeded him. From 1775 to 1789 a vigilant supervision of the affairs of the post-office department was exercised by Congress; but owing to the existence of war during a part of that period, to the depreciation of the currency, and to more or less inefficiency in administra-

tion, the service was a constant burden upon the public treasury—repeated appropriations of money having to be made for its support—and it was otherwise unsatisfactory. It may naturally be supposed that the dispatch of the mails was irregular, and that their security could never be absolutely assured; besides which the rates of postage were exorbitant and varying—not less than eight radical changes having been made in about as many years. The last of these was in 1787, reducing by 25 per cent. the rates fixed by resolution of Oct. 18, 1782, which were as follows (the standard of value being the pennyweight of silver, rated at five-ninetieths of a dollar):

For a single letter, sent any distance under 60 miles, 1 dwt. 8 grs. or 7.4 cents; over 60 and under 100 miles, 2 dwt., or 11.1 cents; over 100 and under 200 miles, 2 dwt. 16 grs., or 14.8 cents; and an advance of 16 grs. for every additional 100 miles.

For a single letter by packet to Europe, 4 dwt., or 22.2 cents. Double rates for double letters, triple rates for triple letters, etc. (Single, double, and triple letters were those composed of one, two, or three sheets of paper, respectively—designations that had previously been used, and continued to be used until the weight standard was adopted.)

During the foregoing period—the period of the Confederation—three very noticeable provisions of law concerning the post were enacted, which deserve especial mention: The first was a provision in the Articles of Confederation (Par. 4 of Art. IX.), which, in giving the power to Congress to establish post-offices and to fix the rates of postage, coupled with the latter the condition that such rates should be sufficient "to defray the expenses of the said office"—a condition that seems to establish the fact that then, at any rate, the postal service was intended to be self-supporting. The second was a provision in the act of Oct. 18, 1782—after hostilities with Great Britain had ceased—which gave to the commander-in-chief of the army, to the President of Congress, and to the governors of the several States, the right to open or to authorize the opening of private letters in the mails. The third was a resolution of Congress passed in secret session Oct. 23, 1786—three years after the treaty of peace with England was signed—which gave a similar power to the Secretary of State for Foreign Affairs. These two latter laws remained in force until 1792. At present it is a penal offence for any officer of the government to invade the privacy of letters.

When the control of postal affairs was transferred, in 1789, from the government of the Confederation to that of the Constitution, the number of post-offices in the thirteen States then composing the Federal Union was less than 100, scattered along a line of post-routes extending from Wiscasset, in the province of Maine, to Savannah, in the State of Georgia, on which line not a single daily mail anywhere existed. The prevailing method of carrying the mails was that primitive one, the horse and rider, which furnished the post-office department with the then appropriate emblem of its seal; the rates of postage, as is shown above, were exorbitant; and the entire postal revenue for a whole year was less than double that of but one great post-office now for a single day. For the first full year after the organization of the post-office department the gross receipts of the whole service did not exceed \$25,000, arising, too, it seems "principally from letters passing from one seaport to another; and for several years thereafter the annual revenue did not reach \$50,000. The revenue of the ten principal post-offices in 1790-91 was for one year as follows:

Philadelphia, Pa.,	\$7,087.06	Petersburg, Va.,	\$1,472.18
New York, N. Y.,	3,788.04	Alexandria, Va.,	1,234.00
Baltimore, Md.,	3,034.64	Fredericksburg, Va.,	1,059.08
Boston, Mass.,	2,883.67	Norfolk, Va.,	1,016.00
Richmond, Va.,	2,777.07	Charleston, S. C.,	810.00

So insignificant was this department of the govern-

ment that we find the gentleman intrusted with its administration in 1790—Samuel Osgood—in a letter to Alexander Hamilton, gravely discussing the question whether the postmaster-general should not be required to occupy the room at the seat of government where the mails were received and dispatched, in order that he might personally superintend the work. The following table shows the condition of the department in 1789, 1790, and 1791 :

Years.	Offices.	Miles.	Revenue.	Expenditures.
1789 (3 months only)	75	2275	\$ 7,510	\$ 7,560
1790.....	75	1875	37,935	32,140
1791.....	89	1905	46,284	36,657

Immediately after the adoption of the Constitution a law was enacted which continued for one year the old post-office establishment of the Confederation; and this law was twice renewed, until in 1792 a general act was passed establishing the post-office department upon substantially the basis which it occupied down to 1836; but this act being limited in its operation to two years, it was found necessary in 1794 to re-enact it, and without limit. The rates of postage fixed by these two laws, continuing until 1799, were as follows, being a considerable increase over the rates previously prevailing :

For every single letter, sent over 30 miles and not over 60 miles, 8 cents; over 60 and not over 100 miles, 10 cents; over 100 and not over 150 miles, 12½ cents; over 150 and not over 200 miles, 15 cents; over 200 and not over 250 miles, 17 cents; over 250 and not over 350 miles, 20 cents; over 350 and not over 450 miles, 22 cents; over 450 miles, 25 cents.

For every double letter, double these rates; triple letters, triple rates; every packet weighing one ounce avoirdupois to pay four rates.

Letters and packets passing by sea to and from the United States, or from one port to another therein, 8, 16, and 24 cents, respectively, for single, double, and triple letters.

Newspapers when sent not over 100 miles, 1 cent each; over 100 miles, 1½ cent. Free exchanges permitted between publishers.

By this act, too, authority was given the Postmaster-General to provide for the transmission of letters to foreign countries by any means which in his judgment might be proper. The following table shows the progress of the service under this schedule of postages, to 1799 :

Years.	Offices.	Miles.	Revenue.	Expenditures.
1792.....	195	5,642	\$ 67,443	\$ 54,530
1793.....	209	5,642	104,746	72,039
1794.....	450	11,984	128,947	89,972
1795.....	453	13,207	160,627	117,903
1796.....	468	13,207	195,066	131,571
1797.....	554	16,180	213,998	150,114
1798.....	639	16,180	232,977	169,084
1799.....	677	16,180	264,846	188,037

By act of March 2, 1799, the rates of postage were changed to the following—a still further advance over the rates of 1789 :

For every single letter, sent not over 40 miles, 8 cents; over 40 and not over 90 miles, 10 cents; over 90 and not over 150 miles, 12½ cents; over 150 and not over 300 miles, 17 cents; over 300 and not over 500 miles, 25 cents. Double, triple, and ounce rates, upon the same principle as in former act.

Letters or packets brought into the United States, or carried from one port therein to another, 6 cents, if for delivery at the port; if for interior delivery, 2 cents more.

Newspapers, same rates as before, except that if for delivery within the State where published 1 cent only on each was chargeable. Free exchanges between publishers.

Magazines and pamphlets, 1 cent a sheet for not over 50 miles; 1½ cent for over 50 and not over 100 miles; and 2 cents for any greater distance. (A sheet was reckoned as 1 page folio, 8 pages octavo, and so on.)

These rates continued without material alteration until Dec. 23, 1811, when an addition of 50 per cent. to all of them was authorized—a war-measure—which addition remained in force until 1816. In 1810, how-

ever, the drop or local rate of postage on letters was fixed, and for the first time, at one cent each. The progress of the service to 1816 is shown in the following table :

Years.	Offices.	Miles.	Revenue.	Expenditures.
1800.....	903	20,817	\$280,804	\$213,994
1805.....	1558	31,076	421,373	377,367
1810.....	2300	36,406	552,366	495,969
1812.....	2610	39,378	649,208	540,165
1814.....	2670	41,736	730,370	727,126
1815.....	3000	43,748	1,043,065	748,121
1816.....	3260	48,673	961,782	804,422

In 1816, under the act of April 9, the following new schedule of rates was authorized, which remained practically unchanged for twenty-nine years :

For a single letter, sent not over 30 miles, 6 cents; over 30 and not over 80 miles, 10 cents; over 80 and not over 150 miles, 12½ cents; over 150 and not over 400 miles, 18 cents; over 400 miles, 25 cents. Double, triple, and ounce rates according to principle of former laws. Same provisions, also, as to newspapers, magazines, and pamphlets, and as to drop letters.

The period during which these rates were in force is memorable for five things : 1st, the efforts of postal reformers to have books admitted to the mails, which, strange as it may appear to us now, were strenuously and successfully resisted by the department; 2d, the transportation of the mails on railroads, which was begun in 1834, and which was, it appears, to the post-office authorities, a decidedly unpleasant innovation; 3d, the radical change, made during the incumbency of Amos Kendall as Postmaster-General, in 1836, and upon his recommendation, in the manner of keeping postal accounts, which before that time had been practically under the control of the post-office department, but which afterwards were placed in charge of an Auditor of the Treasury, and by him audited and settled independently of the Postmaster-General; 4th, the tendency to extravagance in the administration of the postal service, and a manifest indifference to the self-supporting policy that had previously prevailed, as shown by the fact that in nineteen years out of twenty-nine the postal expenditures exceeded the receipts; and 5th, the establishment of the electric telegraph, in 1845, which, though brought into being by the aid of the government, was suffered to pass, in spite of the energetic protests of the Postmaster-General, into private hands. The progress of the service during this period, however, was very great, as is shown by the following table :

Years.	Offices.	Miles.	Revenue.	Expenditures.
1817.....	3,459	52,089	\$1,002,973	\$ 916,515
1818.....	3,618	59,473	1,130,235	1,035,682
1819.....	4,000	67,586	1,204,737	1,117,861
1820.....	4,500	72,492	1,111,927	1,180,926
1825.....	5,677	94,052	1,306,525	1,229,043
1830.....	8,450	115,176	1,850,583	1,932,708
1835.....	10,770	112,774	2,993,356	2,757,350
1840.....	13,468	155,739	4,543,522	4,718,236
1844.....	14,103	144,687	4,237,288	4,296,513
1845.....	14,183	143,940	4,289,841	4,320,732

By act of March 3, 1845, a very marked reduction and simplification was made in the rates of postage, as is seen from the following statement :

For a single letter (not over ½ ounce), sent less than 300 miles, 5 cents; over 300 miles, 10 cents; every additional half ounce an additional rate. Drop letters, 2 cents each. Newspapers of not more than 1900 square inches, sent within 30 miles of the office of publication, free; of less size, sent over 30 miles from office, 1 cent each for not over 100 miles, and 1½ cent for over that distance. Newspapers of greater size, same rates as magazines.

Printed or lithographed circulars, handbills, etc., on sheets not larger than single cap paper, 2 cents a sheet without regard to distance.

Pamphlets, periodicals, and magazines, 2½ cents an ounce without regard to distance. Bound books expressly excluded from the mails.

During the period when these rates were in force—that is to say down to 1851—two events occurred that are worthy of special mention: one was the negotiation of a postal treaty with England—the first in the history of the department—by which the single rate of ocean postage was fixed at 5 cents; and the other was the introduction of postage-stamps in 1847, although their use was not made obligatory until several years afterwards.

Years.	Offices.	Miles.	Revenue.	Expenditures.
1846.....	14,601	152,865	\$3,489,193	\$4,084,297
1847.....	15,146	153,818	3,955,893	3,979,570
1848.....	16,159	163,208	4,371,077	4,326,850
1849.....	16,749	163,703	4,905,176	4,479,049
1850.....	18,417	178,672	5,532,971	5,212,953
1851.....	19,790	196,290	6,727,867	6,278,402

In 1851, by act of March 3, the most remarkable reduction that had yet been made in the rates of postage was authorized. The following were the new rates:

- Every single letter (½ ounce), sent not over 3000 miles, prepaid, 3 cents; not prepaid, 5 cents; any greater distance, double these rates. Drop or local letters, 1 cent each.
- Every additional half ounce, an additional rate.
- Newspapers, weekly, free in county where published; outside of county, 5 to 30 cents a quarter, according to distance; other than weeklies, higher rates, varying according to distance.
- Magazines, books, and other printed matter, 1 cent an ounce for not over 500 miles; 2 cents for over 500 and not over 1500 miles; 3 cents for over 1500 and not over 2500 miles; 4 cents for over 2500 and not over 3500 miles; and 5 cents for over 3500 miles.

In 1852, by act of Aug. 30, the rates on printed matter were radically changed, one cent an ounce being the general rate on newspapers, periodicals, and unsealed circulars, with certain reductions for prepayment, and one cent an ounce the general rate on books when prepaid and sent not over 3000 miles. By this same act stamped envelopes, since become so popular, were authorized.

Again, in 1855, by act of March 3, prepayment of postage on letters was made compulsory—the rates being 3 cents a half ounce for distances not over 3000 miles, and 10 cents for greater distances; drop letters, 1 cent each. By the same act the system for registering letters was introduced—now a very important branch of the postal service.

In 1861, by act of Feb. 27, merchandise was for the first time admitted to the mails—the articles admitted being maps, photographs, phonographic paper, letter envelopes, and seeds and cuttings, postage on all of which was fixed at a cent an ounce for less than 1500 miles, and 2 cents for greater distances. By the same act letter postage to and from the Pacific slope was fixed at 10 cents a half ounce.

The growth of the service to 1863 is shown in the following table:

Years.	Offices.	Miles.	Revenue.	Expenditures.
1852.....	20,901	214,284	\$6,925,971	\$7,108,459
1853.....	22,320	217,743	6,940,725	7,982,957
1854.....	23,548	219,935	6,955,586	8,577,424
1855.....	24,410	227,908	7,342,156	9,968,342
1856.....	25,565	234,642	7,020,822	10,405,286
1857.....	26,586	242,601	8,053,952	11,508,058
1858.....	27,977	260,603	8,186,793	12,722,470
1859.....	28,539	260,052	8,663,484	15,754,093
1860.....	28,498	240,954	8,518,067	19,170,610
1861.....	28,586	140,139*	8,349,296	13,606,759
1862.....	28,875	134,013*	8,299,821	11,125,364
1863.....	29,047	139,598*	11,163,790	11,314,267

* Not including routes in the insurrectionary States.

In 1863, by act of March 3, mail matter was divided into three distinct classes, on which the following rates of postage were chargeable:

- First-class matter, or letters and other written matter, 3 cents a half ounce to any distance; drop-letters, 2 cents a half ounce.

Second-class matter, or newspapers and periodicals issued from a known office of publication, weeklies, 5 cents a quarter for each 4 ounces; semi-weeklies, 10 cents; tri-weeklies, 15 cents; six times a week, 30 cents; seven times a week, 35 cents. Weekly papers in county of publication and exchanges between publishers, free.

Third-class matter, or miscellaneous articles and transient printed matter, 2 cents for each 4 ounces; double this rate for books.

These rates remained practically unchanged for nine years, during which, however, a number of important events occurred, which render this period probably the most memorable in the history of the postal service. One was the meeting of the first International Postal Congress, brought about by the efforts of the United States government begun in 1862, and which was the first step towards the formation of the Universal Postal Union effected eleven years after; another was the establishment of the free-delivery system in 1863; another, the adoption of the great money-order system in 1864; another, the organization of the travelling post-office system in 1863, which has revolutionized the manner of separating the mails; another, the further introduction of merchandise into the mails as authorized by act of June 22, 1864; another, the introduction of envelopes bearing requests to return the letter enclosed to the writer in case of non-delivery; and another, the introduction of stamped newspaper-wrappers. The two latter innovations are purely of American origin. The growth of the service, too, was wonderful, as is shown by the following table:

Years.	Offices.	Miles.	Revenue.	Expenditures.
1864.....	28,878	139,171*	\$12,438,254	\$12,644,786
1865.....	20,550	142,340*	14,556,159	13,694,728
1866.....	23,828	180,921	14,386,986	15,352,079
1867.....	25,163	203,245	15,237,027	19,235,483
1868.....	26,481	216,928	16,392,601	22,730,593
1869.....	27,106	223,721	18,344,511	23,698,131
1870.....	28,492	231,232	19,772,221	23,998,837
1871.....	30,045	238,359	20,037,045	24,390,104
1872.....	31,863	251,398	21,915,426	26,658,192

* Not including routes in the insurrectionary States.

By act of June 8, 1872, another rearrangement of postage rates was made as follows:

First-class matter, 3 cents a half ounce. Drop-letters at free-delivery offices, 2 cents a half ounce; at other offices, 1 cent a half ounce.

Second-class matter issued less than weekly, 1 cent each a quarter; weekly, 5 cents a quarter, less than 4 ounces; weekly, 5 cents a quarter; and 5 cents additional for each issue oftener than once a week. An additional rate for each additional 4 ounces.

Third-class matter, 1 cent for each 2 ounces. Books and samples of minerals, metals, and ores, double this rate.

Two years later than this, by act of June 23, 1874, postage on second-class matter was changed to 3 cents a pound for issues of less frequency than once a week, and to 2 cents a pound for all others; and the rate on third-class matter was made uniform at 1 cent for each 2 ounces. This latter rate was changed, however, by act of March 3, 1875, to a cent an ounce; and in the following year the rate on miscellaneous printed matter was changed back to 1 cent for each 2 ounces. No further changes of postage occurred until 1879; but two or three notable events transpired, which should be mentioned, namely: the abolition of the franking privilege by act of Jan. 31, 1873, and the adoption of official postage-stamps for the payment of postage on official matter—a system that was practically abandoned in 1877; the formation of the Universal Postal Union in 1873, by which international postage was reduced generally to 5 cents a half ounce on letters; and the introduction of postal-cards in 1873. The following table shows the growth of the service to 1879:

Years.	Offices.	Miles.	Revenue.	Expenditures.
1873.....	33,244	256,210	\$22,996,742	\$29,084,946
1874.....	34,294	269,097	26,477,072	32,126,415
1875.....	35,547	277,873	26,791,360	33,611,309
1876.....	36,383	281,798	27,805,908	33,203,488
1877.....	37,345	292,820	27,468,823	33,486,322
1878.....	39,258	301,966	29,277,517	34,165,084
1879.....	40,855	316,711	30,041,983	33,449,898

In 1879, under the act of March 3, a reclassification of mail matter was made, the following being the rates of postage established:

First-class (sealed or written matter), 3 cents a half ounce; postal cards, 1 cent each; drop-letters at free-delivery offices, 2 cents a half ounce; at other offices, 1 cent. Second-class matter, newspapers and periodicals issued regularly from a known office of publication, or by news-agents, 2 cents a pound. Third-class matter (books and miscellaneous printed articles), 1 cent for each 2 ounces. Fourth-class matter (merchandise), 1 cent an ounce.

Since the passage of this act the following important changes have been made in the postal laws:

By act of March 3, 1883, the rate of postage on first-class matter was reduced from 3 to 2 cents a half ounce, the tariff of money-order fees was considerably lowered, and the issue of postal notes was authorized.

By act of June 9, 1884, postage on transient newspapers was fixed at 1 cent for each 4 ounces.

By act of March 3, 1885, the unit of weight of first-class matter was increased—the rate of postage being fixed at 2 cents an ounce instead of a half ounce; the special-delivery system, hereinafter described, was authorized; and the rate of postage on newspapers and periodicals was reduced to 1 cent a pound.

By act of June 29, 1886, the fee for money-orders of less than \$5 was reduced.

In August, 1886, the issue of stamped letter-sheet envelopes was begun, under authority of the act of March 3, 1879.

By act of Jan. 3, 1887, the free-delivery system was extended to places of 10,000 population, or \$10,000 of annual postal revenue.

By act of March 3, 1887, authority was given for the issue of postal-notes by other than money-order offices.

By act of July 24, 1888, the rate of postage on seeds, plants, bulbs, roots, scions, and cuttings was reduced from 1 cent an ounce to 1 cent for 2 ounces.

These changes and the following table bring the service down to the close of the fiscal year ending June 30, 1888:

Years.	Offices.	Miles.	Revenue.	Expenditures.
1890.....	42,989	343,888	\$33,315,479	\$36,542,804
1891.....	44,512	344,006	36,785,398	39,251,736
1892.....	46,231	343,618	41,883,005	40,482,021
1893.....	47,863	353,166	45,508,693	43,282,944
1894.....	50,017	359,530	43,335,959	47,224,560
1895.....	51,232	365,251	42,560,844	50,046,235
1896.....	53,614	368,660	43,948,423	51,004,744
1897.....	55,157	373,142	48,837,609	53,006,194
1898.....	57,376	403,976	52,695,176	55,795,357

The existing rates of postage are as follows, which, taking everything into consideration, are probably the lowest in the world:

On letters or written or sealed matter, 2 cents an ounce.
 On postal cards, 1 cent each.
 On newspapers and periodicals mailed by publishers and news-agents, 1 cent a pound.
 On books, circulars, miscellaneous printed matter, and seeds, bulbs, plants, cuttings, roots and scions, 1 cent for each 2 ounces.
 On all other matter, 1 cent an ounce.
 All matter on official business of the government enclosed in distinctive envelopes or under labels, free.
 Newspapers and periodicals sent by publishers to actual subscribers residing in the county of publication, free.
 All matter sent out by agricultural colleges and agricultural experiment stations on the subject of agriculture, free.
 Letters to countries of the Postal Union, 5 cents a half ounce.

From the foregoing sketch it will be seen that the postal service of the United States, from its humble beginning in 1789, has grown to gigantic proportions. In the course of but one century it has in its progress outstripped the service of many nations whose history goes back beyond the middle ages; and to-day in the general extent of its business it stands conspicuously ahead of all other countries. Let us judge its position by a comparison with the postal business of Great Britain, Germany, and France, the three next great nations of the Universal Postal Union.

The statistics which follow are the latest that are obtainable—those for the United States and Great Britain being taken from the Reports of the Postmasters-General for the two countries, and those for Germany and France from the tabulation of 1886 published by the International Postal Bureau at Berne.

In ascertaining the postal revenue of Great Britain, France, and Germany, the income from the telegraph service is omitted, and in the case of the latter country the income from the service of couriers and the transportation of travellers—none of these branches of business being comprehended in the postal service of the United States. The income of Germany and France is estimated upon the basis of 5 per cent. increase over the actual amount of the preceding year.

In gross postal revenue the showing is as follows:
 United States—(year ending June 30, 1888)..... \$52,695,176
 Germany—(year ending March 31, 1888)..... 45,194,357
 Great Britain—(year ending March 31, 1888)..... 42,362,346
 France—(year ending Dec. 31, 1887)..... 28,779,301

In the number of post-offices the United States has more than the other three countries combined:
 United States—(June 30, 1888)..... 57,376
 Germany—(Dec. 31, 1886)..... 18,688
 Great Britain—(March 31, 1888)..... 17,587
 France—(Dec. 31, 1886)..... 7,296

In the length of mail routes the United States is ahead of the other countries, as is here shown:

United States—length of mail routes in miles—1888	403,976
Germany—“ “ “ “ 1886	85,885
Great Britain—“ “ “ “ 1888*	44,275
France—“ “ “ “ 1886	65,334

In the mileage of mail service annually performed the United States is immeasurably in advance of all other countries:

United States—miles of all service performed in 1888.....	287,651,055
Germany—miles of all service performed in 1886.....	132,011,695
Great Britain—miles of all service performed in 1888*.....	52,669,584
France—miles of all service performed in 1886.....	90,980,803

These figures comprehend an advance of about 10 per cent. over a computation furnished by the Secretary of the General Post-Office in London for the year 1886.

In the number of pieces of mail matter transmitted—which is the best criterion of the magnitude of the postal service—the United States is greatly in the lead, as the following table will show:

Countries.	United States, 1888	Germany, 1886
Letters mailed or delivered	1,769,800,000	720,497,240
Postal Cards “ “	372,200,000	245,282,540
Newspapers “ “	1,063,100,000	523,873,340
Mis. printed matter, pieces		210,108,220
Parcels of merchandise	372,900,000	116,305,050
Total.....	3,578,000,000	1,816,066,390

Countries.	Great Britain, 1888	France, 1886
Letters mailed or delivered	1,512,200,000	591,451,811
Postal Cards “ “	188,800,000	35,923,379
Newspapers “ “	152,300,000	92,957,793
Mis. printed matter, pieces	389,500,000	713,962,439
Parcels of merchandise	36,732,000	28,953,858
Total.....	2,279,532,000	1,463,249,280

The average number of pieces of mail matter to every inhabitant of these countries, upon the basis of the last census, is about as follows: United States, 71; Germany, 41; Great Britain, 61; France, 37.

The gross expenditure of the postal service of the several countries was as follows:

United States, year ending June 30, 1888.....	\$55,795,357
Germany, year ending Mar. 31, 1888 *.....	44,348,939
Great Britain, year ending Mar. 31, 1888.....	28,876,935
France, year ending Dec. 31, 1887 *.....	28,327,666

* These amounts are 5 per cent. over the actual expenditures of the preceding year. They also include the cost of the telegraph service.

There are several branches of the postal service of the United States which deserve special description:

1st. *The Money-Order System*, created by act of Congress of May 17, 1864. The object of this system is to provide the public with the means of making small remittances of money by mail cheaply and safely. This is accomplished through the issue of orders by one postmaster upon another, the orders being issued upon written applications therefor, the purchaser in every case being required to deposit with his application the amount of money which the order calls for, in addition to the fee. The order, after delivery to the purchaser, is usually sent by him to the payee through the mails, though it may be, of course, sent by any means. Money orders are limited by law to \$100, the fees for amounts up to that being as follows: For an order not exceeding \$5, five cents; over \$5 and not over \$10, eight cents; over \$10 and not over \$15, ten cents; over \$15 and not over \$30, 15 cents; over \$30 and not over \$50, 25 cents; over \$50 and not over \$60, 30 cents; over \$60 and not over \$70, 35 cents; over \$70 and not over \$80, 40 cents; over \$80 and up to \$100, 45 cents. The order is always upon a designated postmaster, and therefore can be paid by no other, and it is invalid if not presented within one year from its date. It is assignable to only one payee beyond the first, and cannot be paid unless

the presenter be known to the paying postmaster or be properly identified. The principal security in the money order, however, lies in the leaving out of the order the name of the payee, and in the sending by the issuing to the paying postmaster of a secret letter of advice, giving the payee's name and all the other particulars of the order, which renders it almost impossible to make a mistake in payment. If an order be lost or invalidated by improper assignment or lapse of time or otherwise, it may be duplicated; if it be paid to the wrong person, the government is liable to the owner. The system on June 30, 1888, existed at 8241 post offices. It has upon the whole been profitable to the government, the fees amounting to more than the expenses; besides which a very large amount has been gained—probably over a million dollars—through the loss or non-presentation of orders from the beginning of the system to the present time. As the system is carried on without any working capital except such as accrues from unpaid orders, it is necessary to keep the funds in constant circulation, and as rapidly as possible to accumulate at paying centres the receipts of offices where the issues of orders exceed payments. Every postmaster is therefore required to remit daily to some post-office designated as his depository all his surplus money-order funds—an arrangement which also tends to prevent defalcations. To the country at large the money-order system has been of immeasurable benefit; for it has given a great stimulus to many branches of trade; it has been a not inconsiderable agent in the ceaseless and necessary circulation of money; and it has materially aided through its international branch that wonderful migration of people from the Old to the New World that has made the progress of America one of the marvels of history. Table I. shows the growth of the money-order business from its establishment Nov. 1, 1864, to June 30, 1888.

TABLE I.—U. S. Money-Order System.

Fiscal year (ending June 30).	Offices.	Orders issued.	Orders paid and repaid.	Fees received.	Expenses.	Deficit.	Surplus.
1865.....	419	\$1,360,122.52	\$1,313,577.08	\$11,536.40	\$18,584.37	\$7,047.97
1866.....	766	3,977,259.28	3,903,890.22	35,803.06	28,664.27	\$7,138.79
1867.....	1,224	9,229,327.72	9,071,240.73	70,889.57	44,628.96	26,260.61
1868.....	1,468	16,197,853.47	16,118,537.03	124,503.19	70,345.04	54,158.15
1869.....	1,685	24,848,058.93	24,654,123.46	176,247.87	110,694.00	65,553.87
1870.....	2,076	34,054,184.71	33,927,924.79	235,557.05	145,382.42	90,174.63
1871.....	2,452	42,164,118.03	42,027,336.31	295,563.38	194,381.60	101,181.78
1872.....	2,775	48,515,532.72	48,419,644.97	350,499.40	244,521.63	105,977.77
1873.....	3,069	57,516,216.69	57,295,012.27	354,816.66	286,232.66	68,584.00
1874.....	3,404	74,424,854.71	74,210,156.25	462,238.54	357,040.42	105,198.12
1875.....	3,401	77,431,251.58	77,396,690.75	494,717.27	374,575.18	120,142.09
1876.....	3,697	77,035,972.78	77,106,338.85	647,021.52	456,250.68	190,770.84
1877.....	3,686	72,820,509.70	72,908,475.25	624,409.66	524,478.47	99,931.19
1878.....	4,143	81,442,361.87	81,279,910.80	716,638.98	513,686.61	202,952.37
1879.....	4,512	88,254,641.02	88,006,200.20	799,347.09	575,386.32	223,960.77
1880.....	4,829	100,252,818.83	100,165,982.78	917,091.58	659,516.50	257,575.08
1881.....	5,183	105,075,769.35	104,924,853.61	967,772.93	715,458.29	252,314.64
1882.....	5,491	113,400,118.21	113,388,301.90	1,054,538.62	774,197.45	280,341.17
1883.....	5,927	117,329,406.31	117,344,281.78	1,102,838.42	791,133.75	311,704.67
1884.....	6,310	122,121,261.98	121,971,083.80	950,479.39	702,603.80	247,875.59
1885.....	7,056	117,858,921.27	117,996,205.06	925,125.03	681,150.06	243,974.97
1886.....	7,357	113,819,521.21	113,885,463.04	922,781.97	689,758.38	233,023.59
1887.....	7,853	117,462,660.89	117,264,026.66	914,076.57	402,458.59	511,617.98
1888.....	8,241	119,649,064.98	119,743,345.25	947,316.56	406,043.79	541,272.77
Total.....	1,736,341,816.76	1,734,287,602.84

Money-order arrangements exist between the United States and the following named countries: Great Britain, France, Germany, Switzerland, Belgium, Italy, Portugal, Sweden, Netherlands, Canada, Jamaica, Windward Islands, Leeward Islands, Hawaiian Islands, New Zealand, New South Wales, Tasmania, Victoria, Queensland, Japan, India, Cape Colony, Norway, and Denmark.

By act of March 3, 1883, a new form of money-order has been added to the system's issues—known as the "postal note." These are limited in amount to \$4.99. The fee for issuing them is three cents. They are payable to bearer, but only at the post-office on which drawn, and they are transmitted always at the risk of the purchaser, and not of the government. If not presented within three months from the last

day of the month of issue, they become invalid, though a duplicate may be obtained upon payment of an additional fee. The following table shows the business of the postal-note system since its establishment :

Fiscal year.	Notes issued.	Notes paid and repaid.
1884.....	\$7,411,992.48	\$7,254,125.94
1885.....	9,996,274.37	9,948,023.80
1886.....	11,718,010.05	11,666,930.73
1887.....	11,768,824.81	11,726,767.51
1888.....	12,134,459.04	12,104,881.55

Fiscal year.	Fees received.	Expenditures.
1884.....	\$110,282.88	\$76,389.49
1885.....	152,018.58	91,275.82
1886.....	180,333.15	110,113.30
1887.....	189,844.56	82,870.72
1888.....	200,341.68	82,456.30

2d. *The Registry System*, first authorized by act of March 3, 1855. By this system additional security is intended to be given to valuable matter in its passage through the mails, the means relied on for giving this security consisting of the recording, or registering, of all matter presented for registration, the giving of receipts to the senders at the time of mailing, the receipting and careful handling of the matter by all persons through whose hands it may pass throughout its journey, and the final acknowledgment of receipt by the addressee. Thus a letter registered may be traced from hand to hand until it gets to destination, or, in case of its loss or miscarriage, up to the official who is responsible therefor. To give distinctiveness to registered matter it is enclosed in large colored envelopes, termed "registered package envelopes," which may contain one or more letters to any one office, and the condition of which must be indicated by the indorsements of all who handle it. A bill of lading, or "registry bill" as it is called, accompanies this envelope, which bill after verification is returned by the receiving to the sending postmaster. Every failure to receipt for these envelopes or their contents, every discrepancy between bill and contents, and every loss, is promptly reported and at once investigated. Much of the separate handling of and receipting for registered matter has of late years been obviated by the use of through pouches between prominent offices, the pouches being locked with tell-tale locks that can properly be opened only by the sending and receiving postmasters. Vast amounts of money, bonds, and other valuables are transmitted annually by registered mail, so that its value to the business world is beyond question ; but its greatest value is probably to people at small places where the money-order system does not exist, where banks are unknown, and where railroad, steamboat, and express lines have not been extended; for it brings every one of these little communities into safe and expeditious commercial intercourse with the great cities, and places, as it were, their opulence and variety at its feet. The fee for registering matter is 10 cents, which is in addition to the lawful postage. The system is probably self-sustaining. The number of letters and parcels of matter registered during the past ten fiscal years is as follows :

1879.....	5,429,022	1884.....	11,246,545
1880.....	6,996,513	1885.....	11,043,256
1881.....	8,338,918	1886.....	11,648,227
1882.....	9,627,922	1887.....	12,524,421
1883.....	10,594,716	1888.....	13,677,169

3d. *The Free-Delivery System*, authorized by act of March 3, 1863.—The principal function of this branch of the postal service is to make delivery by regular carriers employed by the government, at the residences of addressees or at other specified places of address, of all mail matter that may arrive or be deposited for local delivery at what are known as free-delivery offices. In connection with this duty is that of collecting matter from designated boxes throughout the cities where the system exists, and mailing it at the

post-office. The term "free-delivery" is not strictly accurate; for while no direct charge is made for collecting or delivering matter by the carriers, there is an indirect charge, made by doubling the local or drop rate of postage on letters at all free-delivery offices. Thus, at an office where carrier delivery is not made, the drop rate on letters is one cent an ounce or fraction thereof; at a free-delivery office the drop rate is two cents—the difference being originally intended to maintain the system. Under the last law passed by Congress affecting the free-delivery system, authority is given the Postmaster-General to establish it at any place having a population of 10,000, or where the gross revenue of the post-office for the preceding year shall have amounted to \$10,000. The total number of free-delivery offices in existence on June 30, 1888, was 358; the number of carriers in service at the same time was 6346; and the number of pieces of matter handled by them during the year ending on that date was as follows :

Letters delivered.....	873,760,692
Postal cards delivered.....	212,426,703
Registered letters delivered.....	4,271,105
Newspapers, etc., delivered.....	428,710,933
Letters collected.....	760,113,963
Postal cards collected.....	223,980,437
Newspapers, etc., collected.....	127,597,925
Whole number of pieces handled.....	2,630,861,758

Table II. shows the growth of the free-delivery service since its establishment. It will be seen that if one-half the postage on local matter at free-delivery offices be taken as the measure of revenue resulting from the establishment and extension of the system, it has been financially a burden to the government from the beginning. If, however, the additional use of the mails, locally and otherwise, which the system undoubtedly influences, with the resulting increase of revenue, be taken into account, to say nothing of the immense amount of office separation of the mails which in the absence of carriers would have to be done by distributing clerks and paid for out of some other item of revenue, the system beyond all question has been self-sustaining. Besides, it handles an enormous amount of matter other than letters, on which no increase of the local rate of postage has been made, and from which, consequently, no increase of revenue has been derived, and it collects for mailing nearly as much matter as it delivers—a service which was probably not intended when the system was created, and which the increase in the drop rate of postage was not expected to pay for.

Prior to 1863 a carrier-delivery service existed at a few of the larger post-offices known as the "penny post"—the carriers being appointed by the department, and being allowed in the way of compensation a fee to be collected from every person to whom matter was delivered. It is a rather remarkable fact that although this system existed in England as far back as the reign of Charles II.—one Wm. Dockwra having successfully introduced it into the city of London—and was a short time afterwards authorized in this country, and sanctioned, after the separation of the colonies from England by repeated acts of Congress, it had not, down to the establishment of the free-delivery system, been extended to more than 15 or 20 post-offices in the whole country. The principal cause of this is to be found, not in the disinclination of the people to patronize the system—for we find them in many places eagerly supporting private letter expresses wherever they were permitted to exist—but in the opposition of postmasters, whose compensation, always partially dependent upon the rent of post-office boxes, the system of carrier delivery was supposed to seriously affect. Some attempts have been made within the last five or six years to bring about the re-establishment of the "penny-post" for places of less population than the law requires as a condition

TABLE II.—Free-Delivery Service of U. S. Post-Office.

Fiscal year (ending June 30).	Offices.	Carriers.	Cost of service.	Postage on local matter.	Excess of cost.	Excess of postage on local matter.
1864.....	66	685	\$317,063.20			
1865.....	45	757	448,664.51			
1866.....	46	863	589,236.41			
1867.....	47	943	699,934.34			
1868.....	48	1,198	995,934.59			
1869.....	48	1,246	1,183,915.31			
1870.....	51	1,362	1,230,079.85	\$681,864.70	\$548,215.15	
1871.....	52	1,419	1,353,923.23	758,120.78	595,802.45	
1872.....	52	1,443	1,385,965.76	907,351.93	478,613.83	
1873.....	52	1,498	1,422,495.48	1,112,251.21	310,244.27	
1874.....	87	2,049	1,802,696.41	1,611,481.66	191,214.75	
1875.....	87	2,195	1,880,041.99	1,947,599.54		\$67,517.55
1876.....	87	2,269	1,981,186.51	2,065,561.73		84,375.22
1877.....	87	2,265	1,893,619.85	2,254,597.83		360,977.98
1878.....	87	2,275	1,824,166.96	2,452,251.51		628,084.55
1879.....	88	2,359	1,947,706.61	2,812,523.86		864,771.14
1880.....	104	2,688	2,353,693.14	3,068,797.14		705,104.00
1881.....	109	2,861	2,499,911.54	3,273,630.39		773,718.85
1882.....	112	3,115	2,623,262.74	3,816,576.09		1,193,313.35
1883.....	154	3,680	3,173,336.51	4,195,230.52		1,021,894.01
1884.....	159	3,890	3,504,206.52	4,777,484.87		1,274,278.35
1885.....	178	4,358	3,985,952.55	5,281,721.10		1,295,768.55
1886.....	181	4,841	4,312,306.70	5,839,242.97		1,526,936.27
1887.....	189	5,310	4,618,692.07	6,691,253.69		2,072,561.62
1888.....	358	6,346	5,422,35.36	7,721,689.16		2,299,332.80

precedent to free-delivery ; but although there is little doubt that such an establishment would prove of great convenience to many communities, and would certainly not to an injurious extent affect the postal revenue, both Congress and the Post-Office Department appear to look upon it with disfavor.

4th. *The Special-Delivery System*, established by authority of the act of March 3, 1885. This system is intended to secure the immediate delivery of mail-matter, on its arrival at the post-office of destination, by means of special messengers employed for the purpose. At first its operations were confined to places having a population of 4000 or more ; but by subsequent law it was extended to all post-offices. The charge for making special delivery is ten cents, which is paid by the sender of the matter affixing to it a large and otherwise distinctive stamp, which is additional to the postage. The amount allowed messengers for every delivery is eight cents, the government thus realizing a profit of two cents. The amount of this profit is about \$30,000 a year. At large post-offices, where the amount of business will warrant it, permanent messengers are employed on special-delivery duty ; at other offices the postmaster effects delivery by any practicable means. The system has met with a reasonable amount of patronage, and may be said to supply a popular want. The following table gives the number of pieces of matter specially delivered since the system was introduced, at offices which are required to make returns :

Fiscal year (ending June 30).	Pieces ord. matter.	Pieces drop matter.	Total.
1886—9 mos. only and at 555 offices.....	622,054	274,200	896,334
1887—at free-delivery offices.....	725,330	299,237	1,024,567
1888—at free-delivery offices.....	899,494	320,782	1,220,276

5th. *The Travelling Post-office System* (generally called the Railway-Mail service).—This great system, whose main function is to make minute distribution of the mails on postal-cars, and to make immediate transfers to connecting lines—so that a letter leaving a given point at the same time as a traveller to the same destination accomplishes its journey at the same time—was begun in an unsystematic and tentative way, and not by creation of law, in the year 1862. Prior to that the work of distributing the mail was done en-

tirely in post-offices, the scheme of distribution, speaking generally, being comprehended in the massing of the mails at certain prominent offices, called "distributing post-offices"—(the number of them varying in different years from about twenty to fifty)—where minuter separation was required before further transmission could be made. The result of that system was, of course, frequent delays, unnecessary handlings, and great expense. The mail-car in those days was simply for freighting mails in bulk : now it is a post-office also, by which not only through mails are carried, but in which way mails are taken on and put off—separated and pouched for all offices on the line and their connections, and for connecting car-lines—while the car is in progress. Much separating work is necessarily still done in post-offices, such as through mails, local mails, and mails to go over other than railway routes ; but in general all mails to go over railroads where postal clerks are employed are pouched to the postal car, and there distributed, with accretions made *en route*, according to schemes intended to secure the utmost possible expedition in transmission. The travelling post-office system was not organized until 1865 : it exists now on nearly every railroad in the United States, employs thousands of officials, who handle the bulk of the entire mail of the country.

6th. *The Dead-Letter Office*.—The history of this office, whose business it is to restore to the owners letters and other mail matter that have failed of delivery, goes back to the early days of the republic, the first "inspector of dead letters" having been appointed under a resolution of the Continental Congress passed Oct. 17, 1777. Prior thereto the subject of undelivered letters had, of course, received some attention—so much so that in 1753 such letters began to be advertised ; but they were not sufficient in numbers to warrant the employment of any separate official for their treatment. For many years after the establishment of the office, everything that came into its keeping was, whenever practicable, restored to the owner ; subsequently, when the business of the office had increased considerably, the rule was changed so as to require restoration of only what was apparently valuable ; but now the original practice is revived, and everything except printed matter of no apparent interest or value, such as advertisements, circulars, etc., is restored. In

the treatment of undelivered matter at post-offices the following rules govern: If the matter bears upon it the name and address of the sender, it is returned to him direct by the postmaster at the end of 30 days; if it bears, in addition, a request to return within a given time, it is returned direct at the end of that time; if it does not bear the name of the sender, it is advertised, and, if not delivered, retained in the post-office 30 days, and finally, if still undelivered, sent to the Dead-Letter Office, where it is opened, if found necessary, and restored to the owner. Weekly returns of such matter are made by postmasters at the larger offices; monthly returns by all others. The registered matter and such as is considered valuable are recorded, and prompt restoration is made of everything of which the ownership can be ascertained. Matter of which the ownership is doubtful or not ascertainable is held subject to reclamation. All foreign dead matter is returned without examination to the country of origin. Much of the matter that reaches the Dead-Letter Office is never restored, especially if no inquiry concerning it is received; as, for example, where neither the sender nor addressee of the matter can be found, or where the writer of a letter has failed to sign his name, or has signed only a part of his name—a not inconsiderable class of letter-writers, by the way—or where, as in the case of parcels, nothing appears to indicate the sender. All moneys obtained from dead letters for which no owner can be found, as well as moneys realized from the sale of unreclaimed parcels—which sale now occurs annually—are deposited in the general treasury. The moneys thus obtained amount to about \$10,000 a year. It is a curious fact that every year there are turned into the Dead-Letter Office a great many letters that bear no superscriptions whatever, but still more curious that the most of these letters are written by business men, and on important business subjects. In the examination of letters in the Dead-Letter Office, it has always been an unwritten law that no employé shall ever divulge any information he may thus acquire; indeed, it has been an established principle, seldom departed from, that the government itself has no right, even though it should be in the interests of public justice, to take advantage of secrets that the business of the Dead-Letter Office may disclose. But it is rather remarkable that no law exists which makes an offence of such a betrayal of trust, although the unauthorized opening of or prying into letters by other postal officials has been prohibited from the foundation of the government, and at times made punishable by death. The following table gives some interesting statistics of dead-letter business for the past 10 years:

Fiscal year.	Dead letters.	Am't realized.
1879.....	2,996,513	\$3,323
1880.....	3,057,141	6,506
1881.....	3,323,621	6,584
1882.....	4,285,285	7,657
1883.....	4,379,398	12,279
1884.....	4,564,451	9,619
1885.....	4,708,240	12,097
1886.....	4,791,698	8,858
1887.....	5,335,363	10,976
1888.....	6,217,876	9,118

7th. *Transportation of the Mails.*—There are five general methods of transporting the mails, namely: by railroads, by mail-messengers, by steamboats, by ocean steamers, and by what is known as "star" service. The pay for railroad transportation is prescribed by law of Congress, the rates being as follows: On routes carrying their whole length an average weight of 200 lbs. of mail a day, \$42.75 per mile per annum; 500 lbs., \$64.12½; 1000 lbs., \$85.50; 1500 lbs., \$106.87½; 2000 lbs., \$128.25; 3500 lbs., \$149.62½; 5000 lbs., \$171, and \$21.37½ for every additional 2000 lbs., the average weight to be ascertained by actual weighing for thirty days once every four years. On

land-grant roads the rates are somewhat less. In addition to these rates, which most postal experts consider too high, the railroad companies are allowed for the use of postal cars furnished by them, in every case where a daily trip is made each way, the following pay: \$25 per mile per annum for cars 40 feet in length; \$30 for 45-foot cars; \$40 for 50-foot cars; and \$50 for 55 or 60-foot cars. Railroad companies are required to transport the mails on their fastest trains; but with a number of trunk lines the department often enters into special arrangements for still faster time, paying for the increased expedition out of an annual appropriation for "special facilities on railroads." The companies are obliged, under a well-established practice having now the force of law, to carry the mails to and fro between railroad stations and post-offices at their own expense, when the distance is not over a quarter of a mile. *Mail-messenger* service is that which comprehends the carriage of the mails between post-offices and railroad and steamboat stations where the distance is over a quarter of a mile; between one station and another of different railroads; between post-offices and their branches in the great cities, and over routes not regularly established as post-routes. This service is usually let to the lowest bidder. *Steamboat service* is contracted for whenever such service is considered necessary—usually for four years, and at the lowest obtainable rates. *Star service* (which includes transportation by wagon, carriage, stage, horseback, or afoot) is let every four years by separate routes to the lowest bidders. For convenience in letting this service the country is divided into four contract sections, a letting of the service being made every year for one-fourth of the country. To provide for service over new routes, or over routes where contractors have failed to perform service, a miscellaneous letting is also made every year. Competition has brought the pay for star service down to low rates—in many cases to rates too low to secure good service. *Ocean steamship service* is, of course, confined to foreign mails, and is usually let for periods of two years. The limit of pay in most cases is the sea-postage of the matter conveyed. The pay for carrying United States mails through one country of the Postal Union to another is regulated by the Postal Union convention.

8th. *Organization.*—The postal service is under the general control of the Postmaster-General, who is, and has been since the administration of President Jackson, a member of the Cabinet. Under him are the First, Second, and Third Assistant Postmasters-General, the Superintendent of the Money-Order System, the General Superintendent of the Railway Mail Service, the Superintendent of Foreign Mails, the Chief Post-office Inspector, and the Superintendent of the Dead-Letter Office, each of whom has under him a corps of clerks and other employés at the seat of government. Besides these there is an officer of the Treasury Department, known as the Auditor of the Treasury for the Post-office Department, who has a close and important connection with the postal service. The several classes of postal officials outside of the department proper at Washington are postmasters and their clerks, letter-carriers, railway postal clerks, mail-messengers, and mail contractors. The First Assistant Postmaster-General has charge of the appointment and qualification of postmasters, the establishment of post-offices, the apportionment among them of the appropriations for clerk-hire, rent, light, and fuel, the supply of stationery, and the operations of the Free-Delivery System. The Second Assistant Postmaster-General has control over the transportation of the mails, the making of contracts therefor, the ascertainment of the pay of railroads for mail service, and the supply of mail-bags, locks, and keys. The duty of the Third Assistant Postmaster-General takes in all business relating to the classification of mail matter and the rates of postage, the collection and deposit of the postal revenues, the payment of

postal indebtedness, the control of the registry and special-delivery systems, and the issue to postmasters of postage-stamps, stamped envelopes, and other forms of stamped paper. The duty of the Auditor is to audit and settle quarterly the accounts of postmasters and other postal officers, and to certify for payment the several classes of postal indebtedness. The duties of the other officers named are indicated by their designations. The number of persons employed in the postal service on the 1st of March, 1887 (not including assistants in post-offices of the third and fourth classes, and employes of mail contractors on star routes), was as follows:

In Department proper at Washington.....	600
In Auditor's office at Washington	404
Postmasters of all classes.....	54,774
Assistant Postmasters, first and second-classes.....	384
Clerks in post-offices of the first and second-classes...	5,781
Messengers, janitors, and laborers in post-offices.....	222
Carriers at free-delivery offices.....	5,206
Post-office inspectors and inspectors' clerks	122
Contractors and sub-contractors, star service	14,533
Contractors and sub-contractors, steamboat service...	126
Special carriers.....	2,433
Mail messengers.....	5,412
Employes in railway-mail service.....	4,760
Miscellaneous.....	33
Total	94,790

About 5 per cent. of this number should be added to bring the statement up to June 30, 1888.

PROPOSED IMPROVEMENTS.

Among the many things that have been urged for the enlargement and improvement of the postal service of the United States these are the most important:

1. The postal service, it is said, is incomplete without the telegraph. Every other great nation has had to attach to its postal system this important medium of transmitting intelligence, and the United States, doubtless, will eventually do so too. If it is to be done at all, however, it ought to be done soon; for the only really equitable mode of beginning such a service would be to buy up all private lines of telegraph, and every year, of course, is adding to their value. The Postmasters General, who have advocated the adoption of the telegraph, are Cave Johnson, in 1845 and 1846, under whose administration it was, by the aid of the government, brought into existence; Alex. W. Randall, in 1868; Jno. A. J. Creswell, in 1871 and 1872; Horace Maynard, in 1880; T. O. Howe, in 1882; Walter Q. Gresham, in 1883; and Don M. Dickinson, in 1888.

2. It is said, too, that the postal service should include a system of savings banks. All over the world, wherever this system exists, the patronage of it proves that the people desire a perfectly safe means of investment for small savings, even though the rate of interest be trifling. In support of the proposition the claim is made that a considerable part of the national debt might be paid off by the money deposited in postal savings banks; or, to speak more accurately, by a proper system of receiving and applying the deposits in such banks a great part of the present bonded debt might be transmuted into a savings-bank debt, held by a greater number of the people, and bearing a much lower rate of interest. The great importance, too, to the government, of the possession of a large amount of ready money in times of national peril or financial stringency, such as would be available under a postal savings-bank system, is manifest.

3. Again, it is said that the present method of compensating railroad companies for transporting the mails should be changed—the government now paying too much for the service. The items, at least, of "postal-car service" and "special facilities on railroads," which now amount annually to about \$2,000,000, should be unknown to the government ledger. That is to say, the railroad companies should

provide, without any addition to the statutory pay for mail transportation, whatever cars are necessary, so constructed as to afford the best possible facilities for postal clerks in the distribution and receipt of the mails, and they should transport these at whatever rate of speed the Postmaster-General might at any time deem necessary, just as is done under the law in England.

4. It is urged, with reason, that the civil service reform should be extended so as to take under its protection every employe of the postal service—not merely the letter-carrier and the clerk, but employes above and below these grades; that every official in the service should have a secure tenure of office co-existent with efficiency and good behavior; and that an equitable system of promotions upon competitive examination should prevail, together with one for the imposition of fines and penalties for improper conduct or inefficient service. No person under such a business-like mode of administering the department should ever be taken into its service except after such an examination, to which any man or woman of good character and sound physique should be eligible, and no one should be dismissed except for cause. In this way the service would secure and retain the best talent and character; and instead of its breeding an official aristocracy, as some over-scrupulous statesmen have apprehended, it would originate the purest kind of an official democracy.

5. As soon as postal business shall have sufficiently increased to allow of it the present absurd distinctions in the rates of postage on mail matter should end. Everything admissible to the mails at all—with the exception, perhaps, of newspapers and periodicals, which might, as at present, be granted better terms than other matter—should be placed on the same footing. The lowest rate of postage compatible with public interests should prevail, and it should be no more on a letter than on anything else. One cent for every two ounces would be a rate simple and sensible, and it would, no doubt, be ultimately profitable.

6. The government should, of course, as the law now requires, exercise a complete monopoly in the carriage of letters for pay. Private letter expresses, district telegraph companies, and the like, which in many of the large cities now invade the rights of the government, should be made to give way. It is admitted, with justice, that the exercise of the government's exclusive right in this respect should carry with it such efficient service as to render any private competition unnecessary.

7. It is further insisted that all the mails for delivery in the great cities should be separated as far as possible during their transit. For example, the mails that go into New York by rail should all be made up *en route*, so as to reach every postal station—and, for that matter, every letter-carrier—without the necessity of separation on their arrival at the post-office, and therefore in the shortest possible time. So the mails that pass from one part of the city to another, and the mails which arrive at and depart from the post-office and stations, should be carried to and fro, not by wagon service, as at present, but by underground steam conveyance. Less expense, greater rapidity of transit, and later hours for closing the mails would thus be secured.

8. The free-delivery system should be greatly extended. If, as can, perhaps, be demonstrated, free delivery is profitable and desirable where there is a population of 10,000, there is no reason why it should not be profitable in a place containing 5000 inhabitants; or, to put it differently, if it be proper to introduce it where half a dozen carriers are needed, it would be proper to extend it to every place where a single carrier could be economically employed. Indeed, in thickly settled parts of the country, the system of rural deliveries might be adopted, the same as exists in England, France, and Germany—the carrier taking

the place of the mail contractor, and collecting from and delivering mail to everybody along his route.

9. The railway officials on all trains that carry mails not in charge of postal clerks should be required to receive mail matter offered to them *en route*, and to deposit it in designated boxes along the line, or at post-offices at the termini of their several runs. In other words, the present law which requires the captain of a steamboat or the mail-carrier on a star-route to receive and properly deposit all mail matter handed to him, should apply equally to the officials of a railroad company. Greater dispatch of matter, and greater convenience to the public, would in innumerable cases result from such a regulation.

10. The system, now existing in the postal service of many European countries, under which reimbursement to a limited amount is made for losses in the mails, should be introduced, as a part of the system of registration.

11. The pneumatic tube system, now existing in London, Paris, Berlin, and Vienna, should be adopted for use in New York, Philadelphia, Chicago, Boston, and St. Louis, as a part of the system for the special delivery of letters.

12. There should be a better method of cancelling the stamps on mail matter than that now in vogue. Several plans to this end might be urged: for example, the use of a cancelling ink which by chemical combination with that used in printing the stamps would effect permanent discoloration; or the use of an ink for printing postage stamps which, while sufficiently strong to resist the ordinary wear and tear to which the stamps are subjected by their holders before use, would yet be so yielding as to give way before such solvents as would be necessary to remove the usual cancelling marks; or the use of a chemically prepared paper in the making of postage stamps, such as would discolor when cancelling inks should be applied, or when efforts should be made to remove the cancelling marks. Under any circumstances, the color of the stamps should be anti-photographic—that is, such a color or colors as will prevent counterfeiting by the aid of photography; and in this event it might be cheaper and better to print the stamps on an ordinary printing machine from electrotypes than from steel plates and by the plate-printing process. The value to the government of any good plan for preventing the counterfeiting or the fraudulent reuse of postage stamps is obvious.

13. The present system of postmarking letters should be improved. Probably over 25 per cent. of all the postmarks on letters mailed in the United States are illegible, causing at times great annoyance and inconvenience. An excellent plan has been suggested as a partial remedy for this trouble: that of having various outline forms of postmark—say a different form for every State—which, if the name of the post-office were indistinct, would assist in its identification.

14. At every place of considerable size—say at every place of 10,000 inhabitants—the government should own the post-office building; and these buildings should be erected and furnished with facilities according to carefully considered plans made upon consultation with postal experts. The result would be an ultimate saving to the government in the item of rent and the prevention of changes in the location of the post-offices; while the transaction of postal business would be expedited and rendered more accurate.

15. The method of ascertaining and fixing the compensation of postmasters should be radically changed; for, as may be seen by any one who gives the subject any consideration, the present plan offers a constant temptation to official dishonesty. The law authorizing this method requires that at what are known as fourth-class post-offices (constituting more than nineteen-twentieths of all the offices) the compensation of postmasters shall be made up mainly of commissions on postage stamps cancelled, the amount of cancellation

at an office being ascertained quarter-yearly from the postmaster's own returns, the verification of which by the auditing office at Washington is simply impracticable; at what are known as presidential offices the compensation is fixed once a year, in even hundreds or thousands of dollars, upon the basis of the gross postal revenue, as reported by the postmasters themselves, the correctness of the reports, as in the case of the fourth-class offices, it being impracticable for the auditing office to determine. The schedule of salaries at the presidential offices is as follows: Where the gross receipts are \$1900 and do not exceed \$2100, the compensation is \$1000 per annum; where the receipts are \$2100 and not over \$2400, the compensation is \$1100; where the receipts are \$2400 and not over \$2700, the compensation is \$1200; and so on through thirty grades, increasing \$100 for each grade up to the three highest, the pay of which is \$4000 per annum where the gross receipts of the office are \$450,000 and not over \$500,000; \$5000 where the gross receipts are \$500,000 and not over \$600,000; and \$6,000 where the gross receipts are in excess of \$600,000. Thus at nearly 55,000 post-offices (the department never knowing the amount of cancellation) the postmasters practically determine their own compensation; at every one of the presidential offices, about 2200 in number, the postmaster has it in his power, whenever the gross receipts approach the maximum of the grade in which for the time being his office is placed, to carry himself, either by forced sales of stamps or false returns of sales, over into a higher grade, and thus increase his compensation. The temptation to do this is very great, in view of the fact that a single dollar's increase of gross revenue may make an increase in the postmaster's compensation of either \$100 or \$1000 according to the grade he may happen to be in. The true policy would seem to be fixed compensation for long periods, or to be varied only when special examination should show an increase to be proper. (M. D.)

POSTAL UNION, UNIVERSAL. This is the name given to an association of nearly all the civilized nations of the world, formed for the purpose of regulating international postal intercourse. The credit of originating this great union (which has been of inestimable service to mankind), or rather of taking the first action that may be said to have brought about its formation, belongs to the government of the United States—the idea having been first suggested in the early part of 1862, to the head of the Post-Office Department, by Hon. John A. Kasson, then First Assistant Postmaster-General. At his request the Postmaster-General, Hon. Montgomery Blair, on Aug. 4, 1862, transmitted, through the Department of State, to the government of every country with which the United States had diplomatic intercourse, a formal invitation to participate in a congress of nations, to assemble at some convenient place in Europe, and which should consider the expediency of establishing a uniform classification and standard of weight for international mail matter, uniform rates of international postage, and uniform systems for regulating the dispatch of matter between the various countries of the world, the transit of matter from one country to another through the intermediary of a third, the registration of matter, the return of undelivered letters, and the transmission of limited amounts of money by means of international orders or drafts. Under this invitation a congress—the first international postal congress that ever assembled—convened at Paris on May 11, 1863, in which there were distinguished representatives of the postal administrations of Austria, Belgium, Costa Rica, Denmark, France, Great Britain, the Hanseatic Cities, Italy, the Netherlands, Portugal, Prussia, the Sandwich Islands, Spain, Switzerland, and the United States. Mr. Kasson represented this country. The utmost harmony and liberality of thought prevailed at the sessions of this congress, and the interchange of ideas and the discussion of principles and policy

gave a great impetus to postal progress. Thirty-one articles of agreement were formally adopted, covering all the propositions made by the United States, except that relating to a money-order system, and establishing principles that are still the basis of all international postal business. The agreement, however, not being of the nature of a formally ratified convention, did not secure a perfect union, did not establish for it a fixed duration, made no arrangements for future congresses, and failed to provide for the adhesion of other nations. The necessity for another congress, therefore, in a few years became manifest; and accordingly, by general consent of the nations represented in the first congress, a second one assembled at Berne, Switzerland, Sept. 15, 1874, and on Oct. 9 agreed to a formal convention, in which the defects of the former agreement were remedied, new provisions adopted, and a name—the "General Postal Union"—given to the association. The duration of the convention was to be not less than three years from July 1, 1875, and the territory to which it applied comprised the United States and the whole of Europe, Asiatic Turkey, Asiatic Russia, Egypt, Iceland and the Faroe Islands as a part of Denmark, the Balearic Islands, the Canaries, the Spanish possessions on the northern coast of Africa and the Spanish postal establishments on the west coast of Morocco as a part of Spain, Algeria as a part of France, Malta as a part of Great Britain, and Madeira and the Azores as a part of Portugal. On May 1, 1878, a third congress assembled at Paris, for the purpose of revising and improving the system established by the congress of Berne, and continued in session until the 4th of the next month, when a new convention was agreed upon, which was to go into effect April 1, 1879, and was to endure for an indefinite period. By this convention the name of the association was changed to the "Universal Postal Union"—by which name it is still known—and the extent of its jurisdiction was greatly enlarged. On Feb. 4, 1885, the fourth postal congress met at Lisbon, and adopted a new convention, which went into effect on April 1, 1886, and which is now in force. The next congress will assemble at Vienna in 1890, unless an earlier session is found to be necessary.

The scope and aim of the Universal Postal Union are vast and noble, and its work admirably executed. It makes a single postal territory of nearly the whole world, uniting all nations under a common idea, subjecting them to the same laws, establishing them all upon a footing of perfect equality, and making the self-interest of each give way before the interest of all. In a word, its conspicuous purpose is the good of mankind. The subjects covered by the Convention of the Postal Union are the classification of mail matter, the rates of postage, the transit of matter between the several countries of the Union, direct and through intermediaries, the charges to be made for such intermediary transit and the manner of their settlement, the reforwarding and return of mail matter, the registration of matter and the charges therefor, a system of indemnifying the owners of mail matter that may be lost, the collection of unpaid postage, and a system for the transmission of letters of declared values. Under it an International Bureau is maintained at Berne, in the Republic of Switzerland, through which, under established rules, correspondence is carried on between the several countries of the Union, relative to its general business, to the settlement of disagreements between two or more countries, to the tabulation and publication of statistics, to the admission of new members to the Union, to proposed changes during the intervals between the congresses, and to all other matters that may be of interest or benefit to the postal world. The rates of international postage as now fixed by the convention are as follows: Letters, 5 cents a half ounce if prepaid, and double this rate (to be collected on delivery of the matter) if not prepaid. Postal cards, 2 cents each. Printed matter, commercial

papers, and samples of merchandise, 1 cent for each two ounces if prepaid, and double this rate if not prepaid.

The Postal Union now comprises the following-named countries: The Argentine Republic, Austria-Hungary, Belgium, Bolivia, Brazil, British India, Bulgaria, Canada, Chili, Colombia, the Independent State of Congo, Costa Rica, Denmark and Danish colonies, Dominican Republic, Ecuador, Egypt, France and French colonies, Germany, Great Britain and British colonies (except the Australian and other Oceanian colonies), Greece, Guatemala, Hayti, Hawaiian Islands, Honduras, Italy, Japan, Liberia, Luxembourg, Mexico, Montenegro, Netherlands and Netherlands colonies, Nicaragua, Norway, Paraguay, Persia, Peru, Portugal and Portuguese colonies, Roumania, Russia, Salvador, Servia, Siam, South-west Africa, Spain and Spanish colonies, Sweden, Switzerland, Tunis, Turkey, Uruguay, and Venezuela.

For further information concerning the Postal Union, see Reports of Postmaster-General of the United States for 1862, 1863, 1874, 1875, 1878, and 1885; also the files of *L'Union Postale*, the official organ of the International Bureau at Berne, and *Documents du Congrès Postal de Lisbonne* (Berne, 1885), and to similar documents of the Congresses of Paris and Berne, published in 1874 and 1878. (M. D.)

POTASH.—The hydrated oxide of potassium, or caustic potash ($K_2O \cdot H_2O$), or, as given by many chemists, KHO), was not known as a separate substance till 1739, in which year its distinction from soda, which it resembles in general properties, was first recognized. In its pure state it is one of the most powerful basic substances known, and is largely employed in the decomposition of saline substances, whose acid combines with the potash. As existing in nature it is of the utmost importance to the growth of plants. It is prepared from the carbonate by boiling with lime, which seizes the carbonic acid and leaves the hydrate in solution. Its most important sources are the potash minerals, carnallite and sylvate, which exist abundantly in the salt mines of Stassfurt, Germany. In a single locality in these mines there is a mass of carnallite equivalent to 6,000,000 tons of chlorate of potassium. Ordinary commercial potash consists of the crude carbonate and hydrate, and is chiefly obtained from wood-ashes, which contain it in abundance. The method pursued in America is to burn large heaps of wood to ashes. These are then placed in tubs made from barrels sawn in half, and with perforated false bottoms. About 5 per cent. of lime is added, and the ashes are leached by successive applications of water, each of which is allowed to stand for an hour or two. The water is then drawn off from the bottom, the first draining being taken to the evaporating pans, while the succeeding portions are kept to use on fresh ashes. Broad, shallow iron pans are used in which the liquid is boiled till it becomes syrupy. It grows solid on cooling. The substance thus obtained is intensely alkaline. When purified by heat, which drives off the sulphur and some other impurities, it becomes of a white, bluish, or pearly cast, and is known as pearlsh. The lime used in its preparation acts to decompose the sulphate of potash, which forms one of the salts of the ashes, and frees the potash.

The growing scarcity of wood has greatly decreased the production of potash in this manner, as has also the competition of foreign potash made from the beet-root sugar waste and from the Stassfurt minerals. In 1880 the American product was 4,571,671 lbs., valued at \$232,643. Potash is a constituent of the abundant mineral felspar, which, however, holds it with such powerful affinity that it cannot be separated with sufficient cheapness. It also exists to the amount of 10 or 12 per cent. in the mineral glauconite of the cretaceous or greensand deposits of New Jersey. This is more easily decomposed than felspar, and is capable of

yielding immense quantities of potash. The greater cheapness of soda has enabled it to replace potash in most cases where an alkali is needed, but a steady demand exists for potash from its special adaptation to certain uses. Its principal uses are in the manufacture of soft soap and of several important salts of potassium. It is also used in the manufacture of glass; some of the best and most costly glasses now made, such as Bohemian white and English flint, being potash glasses. In its pure state potash is sometimes used in sticks and pencils as a cauterizing agent. (C. M.)

POTATO. See AGRICULTURE, Chap. v., 2.

POTATO BEETLE. See COLORADO POTATO BEETLE.

POTT, AUGUST FRIEDRICH (1802-1887), a German philologist, was born at Nettelrede, Hanover, Nov. 14, 1802. Early left an orphan, he was educated at Hanover and studied philology at Göttingen. In 1825 he began to teach at Celle, and two years later received the degree of Ph. D. from the University of Göttingen. In 1829 he went to Berlin, resolved to devote himself to comparative philology, and became associated with Franz Bopp, the pioneer in that department. In 1831 he was a privat-docent at the University of Berlin, and in 1833 was made professor of comparative philology in the University of Halle. His reputation was firmly established by his *Etymologische Forschungen auf dem Gebiete der indogermanischen Sprachen* (2 vols., 1833-36), which work, joined with the labors of Bopp in comparative grammar, introduced a new era in the study of language. Pott continued to revise and enlarge this work, so that it finally occupied eight volumes (1859-76), while he issued numerous volumes and essays on philological subjects. A curious by-product of his labors was his essay, *Die Zigeuner in Europa und Asien* (2 vols., 1845), in which he proved that the language of the Gypsies had originated in India. This work obtained the Volney prize from the French Academy. Other treatises of his relate to the systems of numeration by fives and twenties, to personal and family names, and to the origin of language and of the races of men. He edited Wilhelm von Humboldt's essay, *Ueber die Verschiedenheiten des menschlichen Sprachbaues*, with an introduction (2 vols., 1876). He held his professorship for fifty-four years, meantime receiving marks of honor for his profound learning. The knighthood of the order *pour le mérite* for science and art was awarded to him in 1886. In 1877 he celebrated the jubilee of his taking the doctor's degree, and in 1883 that of his entrance on his professorship. His literary activity was continued until the last. He died at Halle, May 3, 1887. His valuable library was purchased for the University of Pennsylvania.

POTTAWATTAMIES, a tribe of American Indians of the Algonquin family, were found by the French explorers in the lower peninsula of Michigan. They were scattered about in small bands, living by hunting and fishing, though they raised a little maize. The Iroquois drove them westward to Green Bay, where the French established a mission among them. By the favor of the French they increased and greatly extended their territory. They joined in Pontiac's conspiracy in 1763, but during the Revolution favored the English, and annoyed the western settlements. Their head-quarters were then on St. Joseph's River, Mich. They were included in the treaty of 1795 with Gen. Wayne, and afterwards ceded various tracts of land. Under the influence of Tecumseh they joined the British in the war of 1812, and after its close were obliged to give up their lands. In 1838 they numbered 4000, many of them being Catholics. Eventually the greater number settled in Kansas, but in the subsequent troubles of that region they suffered severely. By the treaty of 1862 they were permitted to hold lands in severalty, but the civil war produced delay in carrying out its provisions. In 1867 two-thirds accepted its terms, but its results were not uniform.

While some persons prospered others became paupers. The Prairie band, which had always been less docile, was placed on a reservation in Kansas under the care of the Society of Friends. It contains 77,358 acres, of which 30,900 are tillable, but only 3300 cultivated in 1887. The census then taken showed 474 on the reservation, and about 300 scattered in the States. The Citizens' band are mixed bloods of French descent, who live on the Sac and Fox reservation. They numbered 418 in 1887, lived in houses and cultivated small farms. A Catholic mission school has accommodations for 100 scholars, but is not well attended.

POTTER, ALONZO (1800-1865), bishop of the American Episcopal Church, was born at La Grange, Dutchess co., N. Y., July 10, 1800. After graduating at Union College in 1818 he was a tutor there and professor of mathematics and natural philosophy until 1826. In the meantime he had taken orders in the Episcopal Church in 1822, and was elected president of Geneva College in 1825. He declined this post, but accepted a call to St. Paul's Church, Boston, in 1826. In August, 1831, he returned to Union College as professor of rhetoric and natural philosophy. He married the only daughter of Rev. Elihu Nott, D. D., president of the college. In 1845 he was chosen and consecrated bishop of Pennsylvania. In this office he was energetic in his promotion of church work; he assisted in founding the Protestant Episcopal Hospital and the Divinity School at Philadelphia. The increase of the church necessitated the appointment of an assistant, and afterwards the division of the diocese. But before this was accomplished Bishop Potter died July 4, 1865, at San Francisco, whither he had gone on a visit. While engaged in teaching he published *Political Economy* (1841), and other textbooks. In later years besides editing *Lectures on the Evidence of Christianity* (1855) he published a *Handbook for Readers and Students* (1847), a volume of *Discourses and Charges* (1858), and *Religious Philosophy* (1853). Bishop Howe has edited his *Life* (1871).

POTTER, HORATIO (1802-1887), brother of the preceding and bishop of New York, was born at Beckman, N. Y., Feb. 9, 1802. He graduated at Union College in 1820, and became rector at Saco, Me., in 1828. In 1833 he was called to St. Peter's Church, Albany, and in 1854 he was made provisional bishop of New York. He became bishop in 1861 and discharged the duties of his office until October, 1883, when his nephew, HENRY CODMAN POTTER (b. 1835), was made assistant bishop. Bishop Horatio Potter thenceforth lived in retirement until his death, Jan. 2, 1887. His publications were sermons and charges. The present bishop has published *Sisterhoods and Deaconesses* (1871); *Gates of the East*, a book of travels (1876); *Sermons of the City* (1881).

POTTSTOWN, a borough of Pennsylvania, in Montgomery co., is on the Schuylkill River, at the mouth of Manatawny Creek, 40 miles W. N. W. of Philadelphia, with which it has connection by two railroads. It has 2 banks, 14 churches, a seminary for young ladies, an academy for boys, public schools, 2 daily and 2 weekly newspapers. The industrial works comprise iron-foundries, blast-furnaces, rolling-mills, nail-factories, and car-works. The population in 1880 was 5305.

POTTSVILLE, a city of Pennsylvania, county-seat of Schuylkill co., is on the Schuylkill River, at the mouth of Norwegian Creek, 93 miles N. W. of Philadelphia. It is the northern terminus of the Philadelphia and Reading Railroad, and from it branches extend to Tamaqua, Harrisburg, and other places. It is built on the side of steep hills. It has a court-house, town-hall, 3 national banks, 7 other banks, 20 churches, a high-school and other schools, 3 daily and 6 weekly papers, some of which are German. It is the head-quarters of the anthracite coal trade (see COAL, Vol. II.). It has several rolling-mills, iron-furnaces, found-

dries, machine-shops, saw- and planing-mills. In 1880 it had 13,253 inhabitants.

POUGHKEEPSIE, or POKEEPSIE, a city of New York, the seat of Dutchess co., is on the E. bank of the Hudson River, 81 miles N. of New York city, and 70 miles S. of Albany. It is on the New York Central and Hudson River Railroad, and a ferry connects it with Highland Station on the West Shore Railroad. The New York and Massachusetts Railroad also runs from Poughkeepsie 42 miles to Boston Corners where it connects with other roads. Poughkeepsie has the county buildings and offices, city library, the U. S. Government building, an opera-house, Vassar Institute, Vassar Home for Aged Men, Home for the Friendless, St. Barnabas Hospital, Old Ladies' Home, and Eastman Business College. Just beyond the eastern city limit is VASSAR COLLEGE (q. v.), a noted institution for women. It was founded in 1865 and liberally endowed by Matthew Vassar, to whose generosity the city owes also other institutions. Two miles north of the city is the Hudson River State Hospital for the Insane, erected in 1871, and costing \$750,000. Poughkeepsie has 6 national banks, 1 savings-bank, 3 large hotels, 18 churches, 12 public school buildings, 3 daily and 4 weekly newspapers, besides several periodicals. It has a blast-furnace, rolling-mill, and several breweries. The manufactures comprise silk, boots and shoes, clothing, carriages, iron-ware, etc. The town was settled by the Dutch about 1680. In 1778 the State Legislature met here, and in 1788 the New York Convention here ratified the Federal Constitution. Poughkeepsie was incorporated as a city in 1854. It is on a plateau about 200 feet above the river and is sheltered on the east by high hills. It is laid out with wide streets crossing at right angles. Main street, which extends eastward from the river, is about two miles long. The population in 1880 was 20,207.

The Poughkeepsie Railroad bridge was commenced in 1873, by a company which had obtained from the Legislature a charter, which permitted it to place four piers in the channel of the river. The work was interrupted and remained in a very incomplete state until 1886, when it was resumed and pushed forward that the bridge might be opened for traffic in 1889. The bridge is 3094 feet in length from anchorage to anchorage, and the approaches consist of a viaduct of about 3000 feet in length on the east side and about 1000 feet on the west, making the whole about 7100 feet. The bridge proper rests on 6 piers, 1 on either shore and 4 in the channel. The river piers are carried down to depths of from 125 to 135 feet below the surface. In order to secure a solid foundation open caissons of timber were built 60 feet wide by 100 long, weighted by "pockets" filled with concrete, and sunk by dredging through the open spaces, 12 in number in each caisson. This method, never before used on a large scale, proved entirely successful, the caissons having been sunk by pneumatic caissons, such as were used in the St. Louis and Brooklyn bridges, and with much less danger and expense. As the caissons were sunk they were built up by additions to the top, so that the lower edges rest upon the solid stratum underlying the mud and silt at the bottom of the river. The tops of the caissons are about 20 feet below the surface. The open spaces were then filled with concrete, the top levelled and a solid platform of timber placed upon it, and the masonry built on this. The masonry piers, which are all that show above the water, are 80 feet long each by 25 wide, the length being in the direction of the current, and they are built up to a height of 30 feet above the surface. Upon the piers are erected steel towers 100 feet high, making the height from the water to the under side of the trusses 130 feet. There are 2 rectangular steel truss spans, each of 525 feet and 80 feet high. The 3 other spans are cantilevers, the cantilever arms being 160 feet each and the connecting trusses 212 feet; the height of the connect-

ing trusses is 162 feet from the water surface, and the height of the rail on the top 212 feet. The cantilevers extending from the river piers are counterbalanced by the rectangular trusses, and those on the shore piers by inshore arms, each 200 feet long, attached to the anchorages. About 15,000 tons of steel and over 6000 tons of iron were used. The bridge is calculated to hold with entire safety 2 continuous trains of 85-ton locomotives, covering the whole length of both tracks, the ultimate strength of materials being equal to 5 times this strain. The bridge is intended to furnish a short route between the anthracite coal regions of Pennsylvania and the manufactories of New England. (F. G. M.)

POUJOLAT, JEAN JOSEPH FRANÇOIS (1800-1880) French historian, was born at Fare, Jan. 26, 1800. He was educated at Aix and went to Paris in 1826, where he joined Michaud in preparing the *History of the Crusades*. Together they visited the East and explored especially Syria. These travels were reported in their *Correspondance d'Orient* (7 vols., 1833-35), to which Poujolat added a romance, *La Bedouine* (2 vols., 1835), which was crowned by the Academy. The two historians published also a valuable collection of documents relating to French history from the thirteenth to the end of the eighteenth century (32 vols., 1836-38). A joint visit to Italy gave opportunity for another volume of correspondence, *Toscane et Rome* (1839). After the death of Michaud, Poujolat issued a new edition of his *History* with a preliminary sketch of his life (6 vols., 1840-48). For the remaining half of his life Poujolat labored alone but with undiminished activity. Among his works are *Histoire de Jérusalem* (2 vols., 1841-42); *Histoire de Saint Augustin* (3 vols., 1844), which also was crowned by the Academy; *Voyage en Algérie* (2 vols., 1846); *Histoire de la Revolution française* (2 vols., 1847); *Histoire de France depuis 1814* (4 vols., 1865-67); biographies of Cardinal Maury, Archbishop Sibour, Father Ravignan, and various collections of essays, literary and political. In 1848 Poujolat was elected to the Constituent Assembly, and afterwards to the Legislative Assembly, in which he took part with the Right, or conservative party. Under the Empire he was engaged only in literary work, though he published some pamphlets on the clerical side of controverted questions. One of his latest publications was *Les Folies de ce temps en matière de religion* (1877). He died at Paris, Jan. 5, 1880.

POULTRY. See FOWL.

POURTALES, LOUIS FRANÇOIS DE, COUNT (1833-1880), naturalist, was born at Neuchâtel, Switzerland, March 4, 1833. He was educated as a civil-engineer and followed Prof. Louis Agassiz to America. He served in the U. S. Coast Survey and obtained a high reputation by his papers on the physical geography of the Caribbean Sea and the Gulf Stream. He was also associated with Agassiz in the study of natural history, and in 1873 succeeded him as keeper of the Museum of Comparative Zoölogy at Cambridge, Mass. He died at Beverly, Mass., July 20, 1880.

POWDERLY, TERENCE VINCENT, labor-organizer, was born at Carbondale, Pa., Jan. 22, 1849. His parents were Irish Catholic immigrants and had nine children. After attending school six years, Terence at the age of 13 began to work on a railroad; at 17 he entered a machine-shop and at 19 removed to Scranton, where he became a member of the Machinists' and Blacksmiths' Union. He was soon made secretary of the union and so remained till 1880. In 1873, being discharged on account of his connection with this union, he sought employment in Ohio and at Oil City. He was delegate to the International Union at Louisville in September, 1874, and organized assemblies of the Industrial Brotherhood near Pittsburg. Returning to Scranton he joined the Knights of Labor, and was made secretary of the District Assembly. He was then foreman in locomotive works. The Groenback-

Labor party enlisted his energies and being nominated by it for mayor of Scranton in 1877 he was elected by 531 majority. He was re-elected in 1878, but declined a third term in 1879 when he was made General Master Workman of the Knights of Labor at their Convention in Chicago. In 1881 he urged upon the Knights the abolition of the oaths and the removal of the obligation of secrecy, which was finally accomplished. In 1886 the Knights had 160 District Assemblies, 9000 districts, and 730,000 members; but at the convention at Indianapolis in November, 1888, their total was admitted to be less than 500,000. The constitution adopted in 1878 has been revised at nearly every annual meeting, but Mr. Powderly has been steadily re-elected, although his health has been impaired by devotion to his work. There has been considerable opposition to his policy within the order; the disaffected elements have, however, been steadily overruled, and many have withdrawn on this account.

POWELL, BADEN (1796-1860), an English natural philosopher, was born at Stamford Hill, near London, Aug. 22, 1796. He graduated at Oriel College, Oxford, in 1817, and became Savilian professor of geometry at Oxford in 1827. For many years he was one of a small band at Oxford who kept alive the study of physical sciences when they were regarded with little favor. In 1850, as a member of the Oxford University Commission, he assisted in introducing some modifications which gave those sciences a recognized place in the system of study. He died at London, June 11, 1860. Besides purely scientific treatises he wrote chiefly on the connection between natural science and theology. His principal works are *Historical View of the Physical and Mathematical Sciences* (1834); *Connection of Natural and Divine Truth* (1838); *Christianity without Judaism* (1857); *The Order of Nature considered in Reference to the Claims of Revelation* (1859). To the *Essays and Reviews* (1860) he contributed an essay "On the Study of the Evidences of Christianity."

POWELL, JOHN WESLEY, geologist and anthropologist, was born at Mt. Morris, N. Y., March 24, 1834. The son of a Methodist preacher, he was in early life taken to Wisconsin and Illinois, where he received a common school education and became a teacher. Being also an ardent student of natural history, he gathered specimens for many institutions of learning. Meantime he pursued for two years a special course at Oberlin College, Ohio. In his scientific excursions he descended the Mississippi River in a skiff, and the Ohio in a rowboat. In 1861 he entered the Union army as a private but soon rose to a captaincy. At the battle of Shiloh he lost his right arm, but on his recovery went to the front and was engaged in the Vicksburg and Atlanta campaigns, becoming major of artillery. In 1865 he was made professor of geology in the Wesleyan University, Bloomington, Ill., but this position was soon exchanged for a similar one in the Illinois Normal University. In connection with his college work he undertook in 1867 a scientific exploration of Colorado Territory. This work obtained the attention of the national government, and in 1870 under the authority of Congress he was engaged to explore the region of the Colorado River and its tributaries. During these investigations he became interested in the ancient cities of the Moquis and entered upon ethnological researches, which have greatly affected his subsequent career. In 1879 when the various government surveys of the Territories were consolidated, as he had advised, Major Powell was made director of the bureau of ethnology. In 1881 he became director of the U. S. Geological Survey. This work he has greatly enlarged and thoroughly classified, originating plans for its prosecution, and employing experts where their services were most valuable. Among his reports are *Exploration of the Colorado River* (1874); *Geology of the Uinta Mountains* (1876); *Lands of the Arid Region of the United States* (1879); *Method of Sur-*

veying the Public Domain; Organization and Plan of the U. S. Geological Survey. The *Reports of the Bureau of Ethnology* include *Contributions to North American Ethnology*, *Outlines of the Philosophy of the N. A. Indians*. Other contributions to anthropology are an address on *Mythologic Philosophy* (1875) and *Wyandotte Government*, a study of tribal society. Maj. Powell has been president of the Anthropological Society of Washington since its organization in 1879, and as such has delivered addresses on *Outlines of Sociology* (1882); *Philosophic Bearings of Darwinism* (1883); *Three Methods of Evolution* (1884); *Human Evolution* (1884); *From Savagery to Barbarism* (1885); *From Barbarism to Civilization* (1886); *Evolution of Civilized Man* (1888). Major Powell in 1886 received the degree of Ph.D. from Heidelberg University, Germany, and of LL.D. from Harvard University. In 1887 he was chosen president of the American Association for the Advancement of Science.

PRAIRIE. This term in the French language signifies "a meadow," and takes its derivation from a mediæval Latin *pratori*, a variant of the classical Latin *pratium*, "a field." Its application as the name of an extended plain dates from the planting of the early French settlements in the Mississippi Valley, a large part of whose floor is of a true prairie formation. There is some looseness about the use of the name. In general, a prairie is supposed to be treeless, at least by nature; but in some of the Southern States a flat region of a forest-character is called a "timbered prairie," while a treeless plain of the same district is called a "bald prairie." So in the Gulf States there are what are called *prairies tremblantes*, or "quaking prairies," the surface of which shakes beneath the tread of a person crossing them. Here the tough sward may support herds of cattle, and the unstable plain may even be crossed by lines of railway; yet it would seem that the strata beneath must be of a semi-liquid character. But the true and representative prairies are the great plains of the upper half of the Mississippi Valley, with their extensions northward into Canadian territory, and south-westward to the Gulf and the Rio Grande. It is usual to discriminate between the prairies and the upper plains which skirt the eastern flank of the Rocky Mountains; yet the distinction is in the main arbitrary, for no line of demarcation can be drawn between the prairies and the high sub-Alpine plain. It is certain that very considerable areas of the great prairie-region at one time (and that not very remote, from a geological point of view) were lake-beds, or were the basins of shallow seas. This is proved by abundant and highly characteristic fossil remains. It is possible that, as more than one geologist has asserted, the peculiar fineness of the slowly deposited silt, which has now become a soil, is unfavorable to tree-growth. Another view, and a very reasonable one, is, that the prevalence of great annual prairie-fires, which, in the dense foggage which covers the natural prairie, burn with great intensity, has done much to repress forest growth. Certain it is that almost the only native arboreal growth (and that of few species) is to be found along the water-courses. But at present the prairie fires are limited in range and intensity; and almost everywhere belts of young native or self-planted forest are seen springing up, especially in those regions where the rainfall is considerable. Besides this, in no other part of the United States has the planting of forest trees been undertaken upon so large a scale as in the prairie-regions west of the Mississippi, arboriculture having been stimulated by State and Federal legislation. But the final success of much of this tree-planting is still undecided. It is possible that some drought of exceptional length and severity may yet give a great check to this matter of tree-planting. The *climate* of the prairie-regions, especially towards the mountains on the west, has its drawbacks, such as the tremendous violence of the winds, the scanty rainfall, and the occasional intensity of the winter's cold.

As to whether the dryness of the climate is being lessened by tree-planting and agriculture, opinions differ widely. But the weight of scientific opinion is certainly against the idea that the planting of trees will very materially increase the fall of rain, although the popular view asserts that such an increase has already taken place. That trees by shading the soil make the process of evaporation a slow one is certain. The extension of agriculture also makes the soil more permeable by rains, and thus stores up moisture in it, and the introduction of great systems of irrigation-canals, such as may be seen in Colorado, tends to a similar result.

A comparatively limited part of the true prairie-region is of a dead-level character, though such tracts are not unknown. But most of the prairies have a "rolling" or wavy surface, broken in some parts by "sloughs" or muddy depressions; in others by *coulées*, or dried-up water-courses, which somewhat resemble the *wadies* of Arabia. Elsewhere there are low ridges of sandy or flinty nature, and even considerable areas of soft and wind-worn rock, with deep "draws" or ravines, which furnish good winter harborage for cattle. But these are exceptional.

The prairies are the great grazing region of the United States. The varieties of their grasses are fully described in Section III. of the article on FORAGE CROPS. Two of their most remarkable animals are fully described under ANTELOPE, AMERICAN (also called PRONGHORN) and BISONS (commonly called Buffalo). See also GOPHER, etc. (C. W. G.)

PRAYER. Man has always looked up to a superior power, and has sought its favor or deprecated its anger. That power might be considered as resident in one God or in many gods, but the most barbarous nations have recognized the power and bowed before it. That communication could be had with the divine power was instinctive in the race, and some form of worship (however crude) marked every community. Part of that worship was prayer, the speaking of the worshipper to the deity. It took the form of doxology or supplication, and was generally accompanied with sacrificial rites.

Revelation has made this instinctive principle a clear privilege and duty, and has exhibited its philosophical connection with man's position before God. It is thus shown to be the expression of the heart's faith, receiving all its value from the truth of that faith, that it is not a mere form of words, nor a mere external ritual, but a spiritual action, and that all approaches to God without the interest of the heart are abhorrent to him. Our Lord, in teaching his disciples to pray, gave as the subjects of prayer God's glory upon the earth and our own supply, forgiveness and deliverance from sin. Under the head of our own supply earthly blessings may be considered as appropriate subjects of prayer, but the large preponderance of the other petitions clearly show that earthly blessings should be held in subordination to the spiritual wants of the soul and the world.

Warrant may be found in the Holy Scriptures for either extemporaneous or prepared prayer in public worship. The prayer offered by the church for Peter when he had been seized by Herod (Acts xii. 5) was certainly extemporaneous, while the prayer offered by the church on the deliverance of Peter and John (Acts iv. 24) must have been prepared and learned, or at least uttered by a leader and repeated by the assembly. In no other way can we explain the words "they lifted up their voice to God with one accord and said."

The Christian church has used liturgies in all her history, but not to the exclusion of extemporaneous prayer. (II. C.)

PREBLE, EDWARD (1761-1807), commodore, was born on the present site of Portland, Me., Aug. 15, 1761. His father, Jedidiah Preble (1707-84), was an early settler of that place, a brigadier-general in colonial times, and afterwards a judge and State senator

of Massachusetts. Early in the Revolutionary war Edward had sailed in a privateer, and in 1779 he entered the Massachusetts navy as a midshipman. In the Penobscot expedition he was captured and was confined in the Jersey prisonship at New York. After his liberation he gained distinction by his daring capture of a British brig at Castine, Me. Peace being declared he entered the merchant service, but in 1799, when the navy was reorganized, he was made lieutenant. Soon promoted captain, he had command of the frigate *Essex* (36 guns) sent to protect American commerce in the East Indies. In 1803 he was assigned to the command of the fleet sent against Tripoli. Arriving at Tangiers in October he succeeded in averting a war with Morocco. In November he blockaded the port of Tripoli. Here lay the captured ship Philadelphia, which was destroyed by the gallant *Decatur* Feb. 16, 1804. In August Com. Preble began a series of attacks on the Tripolitan galleys and gunboats, which were protected by batteries on the shore. Though he inflicted much damage his own losses were serious, and on Sept. 4 a powder-ship intended to destroy the enemy's fleet was blown up by a shot from the shore. On Sept. 10 Com. Preble was relieved by Com. Barron and returned to the United States. He died at Portland Aug. 25, 1807.

His nephew, **GEORGE HENRY PREBLE** (1816-1885), rear-admiral, was the son of Capt. Enoch Preble, and was born Feb. 25, 1816. He entered the U. S. navy in 1835, served in the Seminole war in 1841, and on the coast of Mexico in 1847. While commanding the sloop *Macedonian* in 1854 he was sent to punish the Chinese pirates, and in July and August, 1855, he destroyed five of their junks. During the civil war he was engaged in the blockade of the Gulf coast, assisted in the capture of New Orleans, and from 1863 took part in the South Atlantic blockade, sometimes also fighting on shore. He attained the rank of rear-admiral. He died at Brooklyn, Mass., March, 1885. His publications were a *Genealogy of the Preble Family* (1868); *History of the American Flag* (1872; afterwards enlarged; last ed., 1883); and a *History of Steam Navigation* (1884). He contributed the article on FLAG, AMERICAN, to this work.

His cousin, **WILLIAM PITT PREBLE** (1783-1857), was a leader of the Democratic party in Maine, and influential in framing the State constitution in 1819. On the organization of the State government in 1820 he was made a judge of its Supreme Court, and in 1829 he went as U. S. minister to the Netherlands.

PRENTICE, GEORGE DENISON (1802-1870), journalist, was born at Preston, Conn., Dec. 18, 1802. He was educated at Brown University, trained for the law, but destined to be a newspaper editor. In 1828 he established a literary paper at Hartford, Conn., in which many of his own poems, serious and sentimental, appeared. In 1830 he removed to Louisville, Ky., and became editor of the *Journal*, with which his name is constantly associated. His bright wit and sparkling paragraphs made the paper a daily favorite with the people. It formed a connecting link between the poetical, aristocratic South and the practical, progressive West. Prentice was a gallant supporter of Henry Clay, and a firm opponent of secession. When the civil war came his paper, like the State in which he presided, suffered severely. In his later years he gave up the ownership of the *Journal*, though he still contributed to its columns. He died at Louisville, Jan. 22, 1870. From his writings was collected *Prenticeana, or Wit and Humor in Paragraphs* (1860). His poems were never collected in a volume, though specimens may be found in various works.

PRENTISS, GEORGE LEWIS, Presbyterian minister, was born at Gorham, Me., May 12, 1816. He graduated at Bowdoin College in 1835, and studied theology at the Universities of Halle and Berlin. He was pastor of a Congregational church at New Bedford, 1845-51, and of a Presbyterian church in New

York city, 1851-58. He then resigned on account of ill health, and spent two years in Europe. After his return he was pastor of the Church of the Covenant, New York, until 1873, when he became professor of pastoral theology in Union Theological Seminary. Besides sermons he has published memoirs of his brother and his wife.

His wife, ELIZABETH PAYSON PRENTISS (1818-1878), was the daughter of Rev. Edward Payson (*q. v.*), and exhibited the same amiable disposition and fervent piety. She was born at Portland, Maine, Oct. 26, 1818, and in early life was a teacher. She was married in 1845, and after the early death of her children began to write for publication. After some books for children, she gained a wider circle of readers by *Fred, Maria and Me* (1868). But the most marked product of her pen was *Stepping Heavenward* (1869), which has been translated into several languages. Her other books were *Home at Greylock* (1876); *Pennuquid* (1877). She died at Dorset, Vt., Aug. 13, 1878.

His brother, SERGEANT SMITH PRENTISS (1808-1850), noted as an orator, was born at Portland, Me., Sept. 30, 1808. After graduating at Bowdoin College in 1826, he went to Mississippi as a teacher, and there studied law, and was admitted to the bar in 1829. His eloquence gave him success from the start. In 1832 he moved to Vicksburg and won a suit involving title to the most valuable part of the city. The ground which he obtained as his fee made him one of the wealthiest men of Mississippi. He was elected to the State Legislature in 1835, and was Whig candidate for Congress in 1837. His rival, Col. Claiborne, obtained the certificate of election, but Prentiss carried the contest to Washington, and in support of his claim delivered a remarkable speech before the House of Representatives. By the casting vote of the Speaker, James K. Polk, the case was decided against him. Prentiss then returned to Mississippi and entered upon an earnest canvass, after which he was returned to the House by an overwhelming vote. He was, however, embarrassed by the financial troubles of 1837, and served but one term in Congress. After Mississippi repudiated her State bonds, Prentiss, who had earnestly opposed this action, removed to New Orleans in 1845. There he was leader of the bar, and prominent in philanthropic work. He died at Longwood, near Natchez, July 1, 1850. See *Memoir of Sergeant S. Prentiss*, by his brother (2 vols., 1855; new ed., 1879).

PRESBYTERIAN CHURCH. The ENCYCLO-

See Vol. XIX. PÆDIA BUTANNICA gives not only a full statement of the system of Christian faith and church government known as

Presbyterianism, and a history of its progress in Europe, but also an excellent sketch of its introduction and growth in America. The latter part of the article was prepared by Prof. Charles A. Briggs, D.D., and needs only such additions as may bring its statements down to the present time.

"The Presbyterian Church in the United States of America" is the official title of the largest body holding this system of church government. Its present organization dates from Nov. 12, 1869, when the two bodies which had been known as the "Old School" and "New School" since 1837 accepted a plan of union "on the doctrinal and ecclesiastical basis of our common standards." This reunion was the outcome of fraternal feeling, revived and nurtured by joint evangelistic labors during the civil war, especially in the work of the U. S. Christian Commission (*q. v.*). The strength and tendency of this feeling were plainly exhibited at St. Louis in 1866, where the two Assemblies participated in the sacrament of the Lord's Supper. In 1867 a further step was taken when a national Presbyterian convention was held in Philadelphia, over which Mr. George H. Stuart (*q. v.*), who had been president of the U. S. Christian Commission, was called to preside. Although this convention failed of its

grander purpose—the organic union of all American Presbyterians—it was the first practical movement towards the reunion accomplished two years later. The outcome of the friendly discussions of the joint convention needed only to be formulated to be accepted by the churches at large. When this was accomplished the popular rejoicing over the reunion was manifested in raising a memorial fund amounting to \$7,883,984. This fund was chiefly expended in paying church debts and building new churches. In 1871 the Assembly, under the leadership of Rev. Dr. James McCosh, undertook a scheme of ministerial sustentation for the purpose of increasing the salaries of pastors to \$1000 per annum, but in a few years this work was transferred to the Board of Home Missions. A committee on Systematic Beneficence was appointed in 1879, and a committee on Temperance in 1881. A Board of Aid for colleges and academies was established in 1883. The other Boards through which most of the benevolent and missionary work of the church is transacted are of older date, as follows: Board of Home Missions, organized in 1816; Education, 1819; Foreign Missions, 1837; Publication, 1838; Church Erection, 1844; Ministerial Relief, 1855; Freedmen, 1865.

The reports made to the General Assembly in May, 1888, for the year preceding, give the following statistics: Synods, 26; Presbyteries, 202; ministers, 5789; churches, 6543; elders, 22,434; deacons, 7210; communicants, 722,071; Sunday-school membership, 793,442. The receipts for home missions were \$844,696; foreign missions, \$743,495; other general objects, \$602,441; ministerial relief, \$525,555; the contributions to the last-named being intended as a centennial thank-offering. The total receipts for all purposes were \$12,817,783.

"The Presbyterian Church in the United States" is the official title of the body commonly distinguished as the Southern Presbyterian Church, being composed chiefly of ministers and churches in the Southern States. Its organization was effected in 1861, and was due to the separation produced by the civil war. It took its present name in 1865, and in 1886 celebrated its quarter-centennial. The reports made to its General Assembly in May, 1888, for the year preceding, gave the following statistics:—Synods, 13; Presbyteries, 68; ministers, 1129; churches, 2280; elders, 7110; deacons, 5228; communicants, 156,249; Sunday-school membership, 113,901. The receipts for foreign missions were \$73,389; education, \$35,226; and the total for all purposes, \$1,463,473.

These two General Assemblies, distinguished as Northern and Southern, established a system of correspondence in 1882, and in the next year appointed fraternal delegates to each other. In 1885 they agreed upon a joint celebration of the centennial of the original General Assembly, which was accordingly held with great enthusiasm on May 24, 1888, in Philadelphia. The *Addresses* delivered at the several sessions of this celebration by distinguished representatives of both churches have been published.

Committees were appointed by both Assemblies in 1887 to report on the practicability of reunion between these bodies holding a common faith and polity. The report, however, when presented to the Assemblies, encountered some opposition, especially in the Southern church.

For other Presbyterian churches in America see their respective titles. (J. P. L.)

PRESCOTT, WILLIAM (1726-1795), colonel, was born at Groton, Mass., Feb. 20, 1726. He was of the fourth generation from John Prescott, a native of Lincolnshire, England, who settled at Lancaster, Mass. William's first military service was at the capture of Cape Breton in 1754, and his next in the expedition against Acadia in 1756. He had large estates at Pepperell, Mass., and held local offices. In 1774 he was appointed colonel of minute-men, and in the following April he led his regiment to Lexington and then joined

the army at Cambridge. On June 16 he was ordered to throw up defences on Bunker's Hill, and, though the work was done on Breed's Hill, the battle that ensued is known by the former name. (See BUNKER'S HILL.) Col. Prescott had the command throughout and was one of the last to leave the intrenchments. He resigned in 1777, but afterwards joined Gen. Gates's army as a volunteer and was present at Burgoyne's surrender. He was for many years a member of the Massachusetts Legislature. He died Oct. 13, 1795.

His brother, OLIVER PRESCOTT (1731-1804), graduated at Harvard College in 1750 and became a physician. In 1776 he was made brigadier-general of militia and in 1777 he was elected to the supreme executive council of the State. From 1779 till his death he was a judge of probate for Middlesex county. He was active in suppressing Shays's Rebellion.

PRESCOTT, WILLIAM (1762-1844), the son of Col. William Prescott, was a noted lawyer, served in the Massachusetts Legislature and in the governor's council, and was a delegate to the Hartford Convention of 1814. Though twice offered a seat on the bench of the State Supreme Court he declined, but he served as judge of common pleas for Suffolk county. He was the father of the historian WILLIAM HICKLING PRESCOTT (1796-1859), for whom see the ENCYCLOPÆDIA BRITANNICA.

PRESSENSÉ, EDMOND DÉHOULT DE, a French theologian and senator, was born at Paris, Jan. 7, 1824. He studied theology at Lausanne under Vinet, and also at Halle and Berlin. In 1847 he was ordained pastor of the Evangelical Free Church in the Taitbout Chapel at Paris and soon after was made professor in the Free School of Theological Science. He gained high reputation as a pulpit orator and soon devoted himself energetically to the advocacy of the entire separation of church and state. In 1863 the University of Breslau conferred on him the degree of D. D. In 1871 he was elected to the Chamber of Deputies, and during his five years' service voted constantly with the Republican party. In 1883 he was made a life-senator. He is a chevalier of the Legion of Honor. Of his numerous works may be noted *Christianisme dans son application aux questions sociales* (1849); *Le Rédempteur* (1854); *Les trois premiers siècles de l'Église chrétienne* (4 vols., 1858-77); *L'Église et la Révolution française* (1864); *Jésus-Christ, son temps, sa vie, son œuvre* (1866); *Le Concile du Vatican* (1872); *La Liberté religieuse en Europe* (1874); *Études contemporaines* (1880); *Les Origines* (1882); *Variétés morales et politiques* (1885). He founded the *Revue chrétienne* in 1854 and the *Bulletin théologique*. Several of his works have been translated into English by Annie Harwood.

His wife, ELISE F. L. DE PRESSENSÉ, born in Switzerland in 1826, has published several religious stories, including *Rosa* (1858); *Le Journal de Thérèse* (1854); *Bois-Gentil* (1878).

PRESTON, WILLIAM CAMPBELL (1794-1860), statesman, was born at Philadelphia, Dec. 27, 1794. His father, Francis Preston (1766-1835), was then a member of Congress from Virginia. The son studied law with William Wirt at Richmond, and travelled in Europe from 1816 to 1819. He was admitted to the bar at Richmond, but removed to Columbia, S. C., in 1822, and two years later was elected to Congress. He was a leading advocate of free trade and nullification. In the U. S. Senate from 1834 to 1842 he was one of the noted orators. His style was ornate and his elocution graceful. In 1845 he was made president of South Carolina College, and after filling this position with honor for six years he retired on account of ill health. He died at Columbia, May 22, 1860.

His brother, JOHN SMITH PRESTON (1809-1881), was educated at Hampden-Sidney College and at the University of Virginia and studied in the Law School of Harvard College. He married a daughter of Gen. Wade Hampton, of South Carolina, in 1839 and took

part in the nullification movement. He was a member of the South Carolina Legislature from 1848 to 1856, and became noted as a speaker. In February, 1861, he went as a commissioner to Virginia to urge immediate secession. His speech before the Virginia Legislature at that time was his most noted and brilliant effort. During the civil war he served first on the staff of Gen. Beauregard, taking part in the battle of Bull Run, and afterwards was brigadier-general with charge of the conscript department. After the war he went to Europe, where he remained several years. After his return on some notable occasions he delivered addresses in which he maintained with vigor and eloquence the right of secession. He died at Columbia, S. C., May 1, 1881. He was a highly cultivated gentleman and a liberal patron of art.

JAMES PATTON PRESTON (1774-1843), uncle of the preceding, was a colonel in the U. S. army and was wounded in Canada during the war of 1812. He was afterwards governor of Virginia, 1816-19, and State senator. His son, WILLIAM BALLARD PRESTON (1805-1862), was a lawyer and served in Congress as a Whig. He was secretary of the navy under Pres. Taylor and in 1858 went to France to promote the establishment of a French line of steamers to Norfolk. He took part in the Virginia convention in 1861, at first strongly opposing secession, but finally acquiescing. He was afterwards a member of the Confederate Senate till his death.

PREVENTION OF CRUELTY TO ANIMALS. "The American Society for the Prevention of Cruelty to Animals," of the State of New York, the first institution of its kind ever organized in America, was incorporated by an act of the Legislature of the State of New York, passed April 10, 1866. Its founder was Henry Bergh, whose career has been sketched in Vol. I. of this work.

While engaged in his duties as Secretary of the American Legation to Russia, 1862-64, he was much pained at witnessing the brutality of the drivers of the Russian conveyances to their animals, and in several instances interfered in their behalf. Passing through England, on his return homeward, he examined the methods of the Royal S. P. C. A. in London and determined to found a similar institution in New York. Soon after his return home he entered with zeal upon his humane work. He at first solicited the support of prominent citizens and called a meeting, at which officers of the society were elected. Then he applied to the State Legislature for the enactment of laws for the protection of animals, and also for the grant of a charter for the institution. Having secured these, he attacked the problem of obtaining for dumb creatures a proper degree of consideration for their comfort. At first his efforts met with much opposition from the cruel and ridicule from the thoughtless. Nevertheless, he persevered, and by continued efforts, in which at times he personally arrested offenders, he succeeded in winning public commendation for the cause to which he had devoted his services.

In 1871 Louis Bonard, a man of humane and generous nature, died, bequeathing his entire fortune to the society, which placed it on sound basis financially. Since that period numerous other contributions have been received by it, and its power for good largely augmented. The building at the S. E. corner of Fourth avenue and Twenty-second street, in the city of New York, was purchased and altered to adapt it to the purposes of the institution, and the work of reform was proceeded with on a larger scale.

Every form of unnecessary pain inflicted upon animals comes under its supervision. Dog-fighting, cock-fighting, the use of lame, sore, weak, or disabled animals, violent beating, or needless abuse of these creatures, are a few of many kinds of cruelty suppressed by it. It has a regularly uniformed force of officers in New York city and Brooklyn, branch agencies in many counties, and agents in nearly every county in the State

of New York. An important feature of its work is the adoption of a system of transportation for disabled animals in ambulances, in which they can be placed with little discomfort and conveyed to proper places for treatment. Two of these are almost constantly in use in New York city, and one in Brooklyn. A derrick for raising animals out of excavations into which they have fallen is also provided. The society has taken an active part in the erection of numerous drinking-fountains to provide water for men and animals.

Other States have adopted its example, and passed laws for the protection of animals, until at this date 44 societies exist in North and South America, 33 of which are in the United States, all of which have adopted its emblem.

The following table shows, in a condensed form, what has been done during the twenty-two years, 1866-87:

Cases prosecuted in the courts.....	13,850
Disabled animals temporarily suspended from work.....	35,108
Horses, disabled past recovery, humanely destroyed.....	24,099
Disabled horses removed from the streets in the ambulances.....	4,444

The aggregate result for the year 1887 was as follows:

Cases prosecuted in the courts.....	797
Disabled animals temporarily suspended from work.....	3,456
Horses, disabled past recovery, humanely destroyed.....	2,546
Small animals, disabled past recovery, humanely destroyed.....	1,202
Disabled horses removed from the streets in the ambulances.....	522
Complaints received and investigated.....	3,773

Henry Bergh remained its president from the date of its organization until his death, which occurred on March 12, 1888. His nephew, Henry Bergh, was then chosen to succeed him. (E. B.)

PRICE, ELI KIRK (1797-1884), lawyer, was born at East Bradford, Chester co., Pa., July 20, 1797. He was descended from Philip Price, one of the Welsh Quakers who came to Pennsylvania with William Penn in 1682. He was educated at the Friends' School at Westtown, and entered on a mercantile career, but soon turned to the study of law under John Sergeant. Devoting himself chiefly to real estate practice, he became the most eminent lawyer in that branch in Philadelphia. Taught by his experience, he prepared for the Legislature of Pennsylvania drafts of many important acts regulating the holding and transfer of real estate by corporations and individuals. They tended to promote security of title and the welfare of the community by keeping up the improvement of real estate. To him especially was due the act of 1854 by which the various districts of the county of Philadelphia were consolidated into one city. Later labors helped to obtain for that city the land now forming Fairmount Park and to secure within it the holding of the Centennial Exhibition of 1876. After a long, useful, and honored life he died Nov. 15, 1884. He published a few legal treatises, the most important being *The Law of Limitations and Liens against Real Estate* (1857).

PRICE, STERLING (1809-1867), a Confederate general, was born in Prince Edward co., Va., Sept. 14, 1809. He removed to Missouri in 1830, and after service in the State Legislature was elected to Congress in 1845. In the Mexican war he led a Missouri regiment to New Mexico, and was made brigadier-general and military-governor of Chihuahua. He was governor of the State of Missouri from 1853 to 1857. He was a strong advocate of secession, and presided at the State convention of February, 1861. Gov. Claiborne F. Jackson appointed Price major-general of the State

militia, but their efforts to withdraw the State from the Union were baffled by the patriotic energy of F. P. Blair and Gen. N. Lyon, who compelled the State guard at St. Louis to surrender. Price retired to Carthage and gathered an army of 9000 men. Being joined by Gen. Ben. McCulloch, who had brought 3000 from Arkansas, he defeated and killed Lyon at Wilson's Creek Aug. 10. Price, marching to Lexington, Mo., captured 3000 Union men, and then retreated to Arkansas. In March, 1862, he was appointed major-general, and he fought at Pea Ridge and Corinth. He held command of the department of Arkansas in 1863-64, and then joined with C. L. Vandigham and other Northern opponents of the war in forming a secret society called "Knights of the Golden Circle." Price was the "Grand Commander" of this order, and invaded Missouri in September, 1864, expecting to gather an army of knights as he advanced, but his expectations were not realized. Though he reached Jefferson City, he was obliged to flee, closely pursued by Gens. Pleasanton and Curtis. After the close of the war Price went to Mexico and obtained some favor from the Emperor Maximilian, but, on the overthrow of the latter, Price returned to St. Louis, and died Sept. 27, 1867.

PRIESTS. Prof. W. Robertson Smith, in his article See Vol. XIX. BRITANNICA, prefaces his account of p. 724 (p. 743 the Hebrew priesthood by a general description of what he calls the priest-

hood of "the pure Semites," that is to say, of "the ancient Arabs." From what he says the casual reader would be likely to infer that we have some authentic and independent information concerning the practices of "the ancient Arabs," who lived before the beginning of Israelite history. Of course the author did not intend to convey any such impression. No one knows better than he that the alleged facts he presents are derived either from literature and traditions later than the Mohammedan era—say from eight hundred to a thousand or more years later than the latest Old Testament books—or, by processes of pretty remote inference, from incidental notices in earlier literature, the Old Testament itself being the most ancient and most fruitful source of these notices. Evidently, therefore, whatever the value of these views as to the priesthood of the early Semites may be, they can have no very great weight as evidence concerning the Old Testament priesthood. Especially, they have not sufficient weight to entitle them to be preferred, when they come into conflict with reputable testimony. A man who takes a different view of the Old Testament priesthood would make a correspondingly different construction of what information there is concerning the primitive Semitic ideas of priesthood.

Prof. Smith probably would not claim that his account of the matter can possibly be made to agree with most of the Biblical statements concerning it. Suppose we reconstruct the Hexateuch on the plan proposed by his school, distributing its contents over several centuries, and then reconstruct the history of Israel to make it fit the reconstructed Hexateuch, even then the Biblical statements concerning the priests cannot be interpreted so as to agree with his views; the only course open to an advocate of those views is to accept such items of the evidence as agree with his conclusions, and reject the rest. The Biblical account of the priests of Israel is entirely different from his account, and is in every way credible. It has supernatural elements, which are to be dealt with precisely as we deal with supernatural factors anywhere; but, considered as a historical account, it is contradicted by nothing in philology, or in authentic tradition, or in what we know by experience as to the laws of religious phenomena among men.

The Hexateuchal records inform us that Israel had priests before the giving of the law at Sinai, and the setting apart of Aaron and the Levites for sacred

ministry (Ex. xix. 22, 24). They also mention Egyptian, Palestinian, and Midianite priests, with whom Israel came into contact in the pre-Sinaitic times (Gen. xli. 45, 50; xlvii. 22, 26; xiv. 18; Ex. ii. 16; iii. 1; xviii. 1). It is well known that the Egyptian priests were not mere keepers of shrines, but mediators by sacrifices between men and the gods. Among the few items mentioned concerning Jethro the priest is his taking "a burnt offering," in addition to the sacrificial feast he made for Moses and the elders of Israel (Ex. xviii. 12). Israel at that time had a national burnt offering, and a ritual of the sprinkling of blood (Ex. x. 25; xxiv. 5, 6, 8; cf. Heb. ix. 19). Israel was then familiar with the idea of a priesthood, as that of men set apart, having peculiar relations respectively with God, and with other men (Ex. xix. 5, 6). From these facts, from the elaborate account in Num. iii. : viii. 5-22, of the taking of the Levites instead of the first-born, and from the pains taken in the popular legislation in Deuteronomy to define the priests there mentioned as "the Levite priests" (just as if, otherwise, some one might understand that non-Levite priests were meant), it is a highly probable inference (not, perhaps, a necessary inference) that these writers meant to be understood that the priests of Israel, when they came out of Egypt, were "the first-born," and that the Sinaitic legislation superseded this priesthood by that of the tribe of Levi. But whether this view or some other be taken, in any case the early Israelite priests are not mere shrine-keepers, but have a genuine mediatorial priesthood.

In the so-called priest-code legislation, "the priests, the sons of Aaron," are sharply distinguished from the Levites; but in most of the passages where this distinction is defined, "the sons of Aaron" are simply his four sons, whose names are mentioned. That is to say, after the death of Nadab and Abihu, the priests, according to the prevailing, perhaps the exclusive usage of the priest-code, are Aaron, Eleazar, Ithamar, and, in the last year of the wandering, Phinehas, and no others, save that the term "priest" is also applied to future descendants of Aaron, as well as to those then living (Ex. xxviii. 1, 3, 4, 41; xxx. 30; xxix. 29, 30; Lev. vi. 15 [22]; Num. xviii. 1-7; xxvi. 1, 2; xxvii. 2, 19, and scores of other places). Occasionally in these writings the terms "the great priest," or the "anointed priest" are used to distinguish the person who, later, was known as the high-priest (Lev. xxi. 10; Num. xxxv. 25, 28; Lev. iv. 3, 5, 16; vi. 15 [22]), but ordinarily the simple term "priest" is used instead. The especial functions of the priesthood are those of mediation and atonement, in connection with the sacrifices and the holy of holies. In distinction from this the Levites had ministrations, external and internal, in the care of the sanctuary, and were the assistants of the priests.

Doubtless the laws of the priest-code assign to the priests of the times of Moses a vastly greater number of duties than it was possible for three men personally to perform. It matters not how we suppose that the writer of these laws intended us to understand this, whether that Aaron had other sons and grandsons besides Eleazar and Ithamar, acting as priests, or whether a body of Levites performed priestly functions under the name "sons of Aaron," though not lineally descended from him, or whether it was understood that he and his two sons were to do their work largely by deputy, or whether we adopt some other understanding of the matter; in any case the term priest, in the priest-code, is ordinarily used either to describe the person who, later, was known as high-priest, or to describe him and a very limited number of sacerdotal chiefs, associated with him.

From this point of view the alleged contradiction of usage between the priest-code and Deuteronomy vanishes. Deuteronomy and Joshua use the term "the priest" precisely as it is often used in the priest-code, to denote the high-priest of the time, Deut. x. 6;

xvii. 12; xxvi. 3, 4; Josh. xiv. 1; xvii. 4; xix. 51; xxi. 1, 4, 13; xxii. 13, 30, 31, 32 (once "the great priest," Josh. xx. 6, from Num. xxxv.). Apparently, however (the point is disputed), these books also call all Levites priests, insisting mainly on the distinction between a Levite priesthood, and a non-Levite, Deut. xvii. 9, 18; xviii. 1-3; xxi. 5; xxiv. 8; xxvii. 9; xxxi. 9; Josh. iii. 3, 6, 8, etc. The Levite priests principally mentioned in these books are those who have charge of the ark, and the other furniture of the sanctuary, and of its internal services; these functions the priest-code assigns to the Kohathite family of Levites, the family to which Aaron belonged. Naturally, the books of Deuteronomy and Joshua never use the term "sons of Aaron" to denote Eleazar and Ithamar; indeed, they use this term only in one passage (Josh. xxi. 4, 10, 13, 19). Here the sons of Aaron are also called priests, and comprise so large a section of the Kohathite Levitical family that they receive 13 cities, while the remaining Kohathites receive only 10, the other two great Levitical families receiving respectively 13 and 12. Whether we suppose that the lineal descendants of Aaron had now become as numerous as these proportions would indicate, or suppose that these "sons of Aaron" were so called from their habitual functions rather than from their parentage, in any case, the representations of these books are capable of being understood in such a sense that they perfectly agree with the priest-code laws.

Thus understood, the state of the Israelitish priesthood, at the beginning of the period of the judges, was about as follows: There was the high-priest Phinehas, resident in Shiloh, the ordinary seat of the tabernacle and the ark; with him were as many Aaronite priests and other Levites as were needed for service; the corps of service was changing, however, some Levites constantly coming in from their homes, and others returning to their homes; the great body of the Aaronite priests, the Kohathites, the other Levites, and the Gibeonite sanctuary servants dwelt in their respective cities in the various parts of the country, or sojourned where they saw fit.

Are these representations contradicted by the other accounts of the times of the Judges and of David? The statement that "the priest," in the narrative of Eli's time, "is always in the singular" is incorrect (1 Sam. ii. 13, the Hebrew, and i. 3). The statement that "Hophni and Phinehas are not called priests" is also incorrect (i. 3). The statement that they "bore the ark" has no ground in anything said in 1 Sam. The fact is that the term "priest" is here used just as in the priest-code and Deuteronomy and Joshua, sometimes to denote the chief priest, and sometimes to denote subordinate priests. The assertion that "the priest of Shiloh . . . sits enthroned by the doorway, preserving decorum among the worshippers," instead of ministering at the altar, is an instance of purely imaginary exegesis. The statement, "Wherever there was a temple there was an oracle, a kind of sacred lot, . . . which could be drawn only where there was an 'ephod,' and a priest" includes particulars not found in 1 Sam. xiv. 18, 41, Sept.; xxiii. 6 *seq.*, the passages on which it is based. The statement from Ex. xxxiii. 7 *seq.*, that "Moses was the priest and Joshua the ædituus" of a tent-temple in the wilderness, has no foundation either in that passage or elsewhere. To infer that the priest "is not the minister of an altar" from such instances as 1 Sam. xiv. 34, 2 Sam. xxiii. 16, 17—instances that have nothing to do with either priest or altar—is inconsequent reasoning. When one says "It is not clear from 1 Sam. ii. 15 whether even at Shiloh the priests had anything to do with sacrifice," he ignores the apparently clear fact that in that passage the worshippers complain of the priests for violating the precept, Lev. vii. 28-34, that the priests' portion was due *after* the burning of the fat. Moreover, in 1 Sam. ii. 28, and elsewhere in the writings connected

with this period, the relations of the priests to the altar are distinctly affirmed.

Further, the assertion that "priesthood was not yet tied to one family," but that there were then in Israel many different priesthoods of different families, ministering at various sanctuaries, and all counted as equally the legitimate priests of Jehovah, is in contradiction with 1 Sam. ii. 27, and with all the account that is given of the priests mentioned in the Books of Samuel, as being the descendants of either Eleazar or Ithamar, the sons of Aaron. The Hebrew text says, not that "The temple at Shiloh . . . was the lineal descendant of the Mosaic sanctuary, . . . and its priests claimed kin with Moses himself," but that the Mosaic sanctuary either was itself the temple at Shiloh, or was there at the temple, 1 Sam. ii. 22; that its priests claimed kin with Moses appears in no other way than by their claiming descent from Aaron. The assertion that "this sanctuary was hardly visited from beyond Mount Ephraim" does not agree with the statements in the narrative, 1 Sam. ii. 14, 22, 24, 28, iii. 20, etc., to the effect that "all Israel" came up thither.

Evidently, the priesthood of Micah's son, Jud. xvii., is not recognized by the writer of Judges as legal. No more is the priesthood of Jonathan, Jud. xviii., although the facts in the case show that the priestly character of the tribe of Levi was then recognized. We have no information as to the descent of Eleazar, 1 Sam. vii. 1, and no intimation that his consecration to be keeper of the ark was regarded as giving him the character of a priest. The priesthood of David's sons, 2 Sam. viii. 18, is best understood as an irregularity of the same nature with the contemporary attempt to carry the ark on a cart, instead of on the shoulders of men. (See paragraph on "David's Period of Rest" in article ISRAEL).

If it is fair to infer from Dent. xxxiii. 8-10 that "the ritual functions of the priesthood still appear as secondary to that of declaring the sentence of God," it is equally fair to draw the same inference from the yet more decided passage in Malachi ii. 5-8. That is, this double function of the priests belongs equally to the latest times of the Old Testament, and to the times when Dent. xxxiii. was written. The fact is that the Old Testament attributes it to the priests of Israel of every date. And at all dates the function of the priests in regard to the law differs from that of the prophets; the priest administered and interpreted the law that the prophet brought from Jehovah.

In fine, the Old Testament account of the priesthood of Aaron and Levi is that it was organized in the time of Moses; that from the death of Joshua to the later years of David it maintained its succession, though in those troubled times it was largely shorn of its dignity, and often compelled to share the field with illegitimate rival priesthoods; that it suddenly rose to magnificence with the quick blossoming out of Israelite greatness that marked the times following David's conquests; that from the death of Solomon to the Babylonish exile it was maintained in Judah, but with times of decline and times of revival, according to the characters and circumstances of the various kings; that it was preserved through the exile, and restored in the times of the second temple; that it underwent reorganizations, with changes more or less marked, in the times of David, and again after the exile. The view of the matter that represents the priesthood as a gradual growth in the times later than the judges, through the consolidating of the shrine-keepers of the various high places, attaining its distinctive character only in the post-exilic times, is a view that makes more difficulties than it solves, besides being contradictory to the only sources of information we have on the subject. (w. j. n.)

PRIME, SAMUEL IRENÆUS (1812-1885), Presbyterian editor and author, was born at Ballston, N. Y., Nov. 4, 1812. His grandfather, Benjamin Young Prime (1733-1791), was a learned physician of New-

York city, who wrote several Revolutionary songs. His father, Rev. Nathaniel Scudder Prime (1785-1856), was an able preacher and teacher. Irenæus graduated at Williams College in 1829, studied theology at Princeton, and entered the Presbyterian ministry in 1833. He had pastoral charges at Ballston Spa and Mattawan, but in 1840 was compelled by ill health to relinquish preaching. He then became editor of the *New York Observer*, which by his able management was rendered one of the most successful religious newspapers. Dr. Prime's visits to Europe and the East in 1853, 1866, and 1876 were narrated in his paper, and these letters afterwards published in volumes. His personal connection with the religious movements of his time gave variety and freshness to his writings. He took a prominent part in the organization and various meetings of the Evangelical Alliance. About fifty volumes are attributed to his pen. Among these, besides his books of travel, the three series of *Irenæus Letters* are the most attractive. The third series, published posthumously, is chiefly autobiographic. He had also prepared biographies of Rev. Nicholas Murray, known as Kirwan (1862), and of Samuel F. B. Morse (1875). His most widely circulated volume was *The Power of Prayer* (1859), which gave the history of the Fulton street Prayer Meeting in New York. He published three later books on the same subject, the last being *Prayer and its Answer* (1882). He died on July 18, 1885, at Manchester, Vt., whither he had gone on a vacation journey.

His brother, WILLIAM COWPER PRIME, was born at Cambridge, N. Y., Oct. 31, 1825. He graduated at Princeton College in 1843 and became a lawyer in New York city. He was a frequent contributor to the newspapers and was editor of the *New York Journal of Commerce* for many years. Much of his leisure was devoted to numismatics and ceramics. He has published *The Old House by the River* (1853); *Boat-Life in Egypt and Nubia* (1857); *Tent-Life in the Holy Land* (1857); *Coins, Medals and Seals* (1860); *I go-a-fishing* (1873); and a handsomely illustrated work on *Pottery and Porcelain*. He has also published monographs on the hymn *O Mother dear, Jerusalem* (1865) and on the *Holy Cross* (1877). His valuable ceramic collection has been presented to Princeton College.

Another brother, EDWARD DORR GRIFFIN PRIME, was born at Cambridge, N. Y., Nov. 2, 1814. He graduated at Union College in 1832 and at Princeton Theological Seminary in 1838. He was pastor of a Presbyterian church at Scotchtown, N. Y., 1839-51. He had charge of the American chapel at Rome in 1854-55, and then returned to New York to assist in editing the *New York Observer*. In 1865 he became also one of its proprietors. He has published *Around the World* (1871) and *Forty Years in the Turkish Empire* (1875), the last being a biography of Rev. William Goodell.

PRIMROSE (Lat. *prima rosa*, the first rose), a handsome flowering shrub, genus *Primula*, largely European in habitat, 5 species growing wild in Great Britain. Different species are known by the common names of Primrose, Cowslip, and Oxlip, the European *P. grandiflora* being the typical primrose. The Eastern United States have but two species of the genus. One of these, *P. farinosa*, the bird's-eye primrose, is also a native of England and other parts of Europe. It is distinguished by a white meanness on the underside of the leaves, the flower stems, and the calyx, the flowers being of a pale lilac color with yellow centre. It is a rare plant, found on the northern borders of the States. Another rare species, *P. mistassinica*, occurs from Maine to Wisconsin along the lake shores. It is a pretty little species bearing from 1 to 8 fresh-colored flowers on a stem 2 to 6 inches high. Several other species occur in the far West, the most important being *P. Parryi*, found originally on Pike's Peak, and since then on several other Rocky Mountain peaks. It is the most beautiful member of the genus, its flowers

being very large and of the richest purple hue. Unfortunately its native habitat, on the banks of streams fed with ice-cold waters from melting snows, unfits it for warmer situations, and it does not yield kindly to cultivation. The American Cowslip, *Dodecatheon Meadia*, one of our most beautiful wild flowers, belongs to another genus of the same family. It is found in woods from Pennsylvania to Wisconsin and southwardly, and bears a gracefully drooping cluster of pale purple flowers. The beautiful garden flowers called Polyanthus and Auricula are results of cultivation of species of the primrose genus. (C. M.)

PRINCETON COLLEGE. See NEW JERSEY, COLLEGE OF, and THEOLOGICAL SEMINARIES.

PRINCIPAL AND AGENT. Agency is founded upon a contract, either express or implied, by which one of the parties confides to the other the management of some business to be transacted in his name or on his account, and by which the other assumes to do the business, and to render an account of it. The authority may be by deed or writing, or verbal merely. The agency may be inferred from the relation of the parties and the nature of the employment, without proof of any express appointment. If the agent is to convey or complete the conveyance of land or interests therein, however, the appointment must be in writing. The agency must be previously given or subsequently adopted. Acquiescence in the assumed authority of another when his acts are known to the principal is equivalent to an express authority. Thus it has been held that if a confidential clerk has been accustomed to draw checks for his principal, and has occasionally been permitted to endorse for him, the jury would be warranted to infer a general authority to endorse.

An agent intrusted with general powers must exercise a sound discretion, and he has all the implied powers which are within the scope of the employment. If his powers are limited, he must strictly follow them: he cannot have an adverse interest or employment, as to represent both buyer and seller. If an agent exceeds his powers, his principal is not liable on the contract except so far as the agent was authorized to go. If the agent executes his commission in part only, the principal is liable in some cases, as if the agent was empowered to buy a farm of fifty acres and he bought one of forty acres, corresponding to the directions as nearly as possible. The acts of a general agent, with power to transact all the principal's business of a particular kind, or at a particular place, will bind the principal so long as the agent keeps within the general scope of his authority, though he may act contrary to private instructions. But an agent appointed for a particular purpose, with limited power, cannot bind his principal if he exceeds that power. Any one dealing with such an agent does so at his peril, when the agent passes the precise limits of his power; as where C, a holder of a bill of exchange, desired A to get it discounted, but refused to endorse it, and A procured B's endorsement to it, it was held that C was not bound, A being a special agent with limited authority, not to endorse the bill. The presumption of an authority to sell is inferred in some cases from the nature of the business of the agent, as if a broker be intrusted by a merchant with goods, the principal would be bound by a sale of them. A factor, who buys or sells on commission, may sell on credit if the usage of the trade is such, provided he be not restrained by his instructions, does not give an unreasonably extended credit, and uses due diligence to ascertain the solvency of the purchaser. He cannot sell on credit, however, where such is not the usage, as in a sale of stock. A note taken in this way by a factor belongs to the principal, even if the factor has sold without disclosing his principal. Should the factor fail, the note would not pass to his assignees upon the doctrine that the principal may follow his goods or the proceeds into the hands of the agent or of his legal representatives or assignees.

The sale by an agent on what is known as a *Del Credere* commission, *i. e.*, on credit at his own risk, for an additional premium, has generally been held to substitute the agent's liability to the principal for that of the purchaser.

A factor cannot pledge the goods of his principal for his own debt. In such case the principal may look to the pledgee for the goods: there is an exception to this rule, however, in the case of negotiable paper, unless notice of the fraud or want of title can be brought home to the endorsee.

Where an agent is duly constituted, and names his principal, and contracts in his name, without exceeding his authority, the principal becomes responsible: the agent is personally liable only when the principal is not known, or where there is no responsible principal, or where the agent undertakes in his own name, or exceeds his power. If the agent buys in his own name, but for the benefit of the principal, without disclosing his name, both are bound, provided the goods reach the principal, or the agent acted in the business intrusted to him and within his power. If the authority of the agent be coupled with an interest in the property, he may sell in his own name and be personally liable, *e. g.*, the case of a master of a ship, or a mortgagee. It has been generally held that an agent cannot be sued on a written contract binding the principal only, made by the agent without authority. Where goods have been sold by a factor, the owner may call upon the purchaser for the price before payment to the factor, and a payment to the factor after notice from the owner not to pay would not prejudice the rights of the owner. Where a party dealing with an agent, knowing him to be such, elects to make the agent his debtor, he releases the principal. It has been generally held that an agent, making a contract on behalf of a government, is not responsible himself, though by the terms of the contract he might be if it were private: the presumption in such case is that the party who deals with a public agent relies on the good faith and standing of the government.

The general principle is that an agent is liable to third persons for acts of misfeasance and positive wrong; but for mere non-feasance and negligence in the course of his employment, he is answerable only to his principal, and the principal is answerable to the third party.

Since agency is generally a personal trust, the principal employing the agent from the opinion which he has of his personal skill and integrity, the latter cannot as a general thing delegate the confidence reposed in him to another. In some cases, however, a usage of trade has been held to authorize an agent to employ a broker.

A factor has a lien on the goods of his principal in his possession, or on the proceeds if he has sold the goods, for his charges and commissions. In like manner attorneys, bankers, *etc.*, have a lien on the papers of their clients for the amount of their charges.

The authority of the agent may terminate (1) *by his death*; this results from the personal nature of the trust; (2) *by the principal's revocation*, in which case the agent must immediately be notified: all acts of the agent under the agency previous to notification are binding on the principal: so also if the agent had concealed the fact of notification, and the public had no means of knowing of it; (3) *by a change in the state or condition of the principal*, as by his bankruptcy, or lunacy, or the marriage of a *feme sole* principal; (4) *by the death of the principal*: under the civil law the acts of an agent, done *bona fide*, after the death of the principal, but before notice of it, bind his representatives. In England and America, however, it has generally been held that the death of the principal is an instantaneous and absolute revocation of the agent's authority, unless the agent's power be coupled with an interest. (T. R.)

PRINTING. See TYPOGRAPHY.

PRISON DISCIPLINE. Prisons are as old as history. Eighteen centuries before the Christian era

Joseph, in Egypt, was in prison, and Egyptian monuments testify clearly that prisons were common on the Nile many centuries before. In Chinese annals prisons are mentioned a thousand years before the time of Joseph, and doubtless they have been a necessity wherever an organized government has been maintained.

Prior to the present century, however, prison management with rare exceptions seems to have been little else than organized cruelty. The founder of Christianity had taught that mercy to prisoners was a sign of his coming, and had inculcated the remembrance of prisoners as brethren in bonds, but yet in the practical administration of prisons the hearts of rulers seem to have been hardened, and darkness reigned supreme. It is true the church did something, and under Constantine and succeeding Christian emperors the bishops were authorized to visit prisons with a view to their amelioration, and under Theodosius II. and Justinian, criminal codes were somewhat improved, but the results were not large, and prison reform as a continuous entity had no abiding-place upon the earth until the beginning of the present century.

When we remember that through the Christian centuries the typical prisons were the Mamertine at Rome, the Tower in London, the Bastille in France, the Spielberg in Austria, the Plombs of Venice, and the dungeons of the Inquisition, we may rest assured that the horrors of prisons, in all ages, cannot well be exaggerated. The dark ages of prisons were very dark, and their annals are an interesting and instructive study, but the purview of this article is modern and local rather than ancient or general, and will be confined almost entirely to the United States of America. The history and management of prisons in Europe and other countries of the Eastern Hemisphere have been fully and clearly presented in the *ENCYCLOPÆDIA BRITANNICA*, which should be consulted by those who desire additional information upon this topic.

Penology as a practical science, and a positive force in the world, in the main, had its origin with John Howard. As Paul was the apostle of Christianity to the Gentiles, so Howard was the apostle of prison reform to modern nations. As Paul was converted by special revelation on his way to Damascus, so Howard was converted by the revelations of Bedford gaol. Both served the same master, and both died as martyrs. Paul in the Mamertine prison at Rome, and Howard in a lazaretto at Kherston, near the Black Sea.

The investigations and revelations of Howard attracted attention in all civilized countries, but curiously the fruition of his work, to any large extent, began in America. Howard began his work in 1773, and his first report was made in 1774. On Feb. 2, 1776, the first Prison Reform Association in the world was organized in Philadelphia. It was called "The Philadelphia Society for Assisting Distressed Prisoners;" but in September of the following year the British army entered this city, and the society was dissolved.

Ten years later, May 8, 1787, peace being restored, the society was reorganized, and has continued its beneficent work until the present.

The fact that over one hundred prominent men of Philadelphia (among whom were Benjamin Rush and Benjamin Franklin) signed the original constitution of the society on the day of its adoption indicates the aroused condition of public sentiment at the time, and enables us to understand the reasons for the rapid progress made in the amelioration of the criminal laws of Pennsylvania, and in the improvement of prisons. The impelling motive of the society is indicated in the closing paragraph of its first appeal to the community for funds to carry on its work: "To a people professing Christianity it will be sufficient only to mention that acts of charity to the miserable tenants of prisons are upon record amongst the first Christian duties.

From ladies therefore whom Heaven has blessed with affluence and the greater gift of sympathy—from gentlemen who acknowledge the obligations of humanity—and from the followers of the compassionate Saviour of mankind, of every rank and description, the society thus humbly solicits an addition to its funds."

Perhaps a more thorough transformation in the character of a penal code, by peaceful legislation, is not recorded in the world's history than that which took place in the penal code of Pennsylvania during the eighteen years immediately succeeding the Declaration of Independence. When the Revolution commenced, nearly a score of crimes were capital. High treason, petit treason, murder, robbery, burglary, rape, sodomy, malicious maiming, manslaughter by stabbing, witchcraft, arson, and a second conviction of any crime except larceny, counterfeiting, or passing counterfeit money or bills of credit, counterfeit gold or silver coin, were all punishable with death; but by 1794 such progress had been made that it was ordained that no crime should be punished with death except murder in the first degree.

The Pennsylvania society began its work on the very day of its organization by securing the release of a prisoner held in violation of law and followed it up by persistent and continuous efforts for a more humane administration of prisons. The city prison of Philadelphia secured special attention, and the society protested against its abuses in vigorous language: (1) that the clothing of the prisoners was insufficient; (2) that the daily allowance to prisoners committed for trial was only half of a four-penny loaf, while those detained as witnesses had no allowance at all; (3) no provision was made for decent lodging, the inmates of the gaol lying indiscriminately upon the floor, unless supplied with something better by their friends; (4) the indiscriminate intermingling of criminals, untried prisoners, and debtors was another monstrous abuse, and led in many instances to the conversion of debtors and innocent parties into criminals; (5) that parents were allowed to have their children with them in gaol, and young offenders were exposed to the corrupting influences of association with confirmed and reckless villains; (6) it was presented as a radical evil that a large proportion of prisoners were unemployed; and further it was maintained that labor, even in the public streets, was preferable to sheer idleness within the walls.

In view of these considerations the society recommended "The classification of prisoners, and as far as possible individual reformation with labor in seclusion, and the interdiction of all intoxicating drinks." And so energetically were these points pressed upon the Legislature that on April 5, 1790, an act was passed to reform the penal code of the State. By this act the principle of separation was recognized so far as "hardened and atrocious" offenders were concerned, and intoxicating drinks were entirely prohibited. In 1794 this act was amended so as to require the separation and seclusion of *all* convicts, and, as has already been stated, the death penalty was abolished in all cases except for murder.

The society did not stop here, for we find them in 1796 pressing upon the Legislature the abolition of exacting fees as a condition of liberation from imprisonment. Also the subjection of prisoners to the pillory, the whipping-post, the branding-iron, and cropping, together with exposure to the gaze and taunts of the rabble with external marks of degradation such as the clog and chain upon the neck or leg. When we remember that all these occurred twenty years before Elizabeth Fry exposed the horrors of Newgate in London, and nearly thirty years before remedial legislation was obtained from the British Parliament, it is apparent that the State of Pennsylvania was in advance of all other civilized countries in the matter of prison reform.

As the years went on additional improvements were secured in the criminal laws of Pennsylvania, until at

last the greatest advance in prison reform, which had yet been made in the world was obtained by the creation and completion of the Eastern Penitentiary at Philadelphia, which was opened on Oct. 25, 1829. This prison soon became famous, and attracted attention in all civilized countries, and imitation in many; and even now, after a lapse of sixty years, it ranks as one of the best managed prisons in the world.

The system of cellular separation, or, as it is more generally called, solitary confinement of prisoners, was here for the first time put into operation as an entirety, and has since been known in penological science as the "Pennsylvania System." The entire and permanent separation of prisoners under sentence, as required by the Pennsylvania system, is not now generally approved by penologists, and has been abandoned in all other convict-prisons in the United States, and largely in other countries, but for prisoners awaiting trial, and for brief periods after sentence as an initiatory stage of prison discipline, it is almost universally considered desirable by penologists.

At Philadelphia the system is no longer enforced in its original strictness, and prisoners are brought into such frequent contact with prison officials, and with individual prisoners, as to obviate largely the evils of entire isolation. In Belgium, also, where the system was adopted in all convict-prisons, the severity of continued separation has been largely relaxed, and such improvements have been introduced as to recall the favorable attention of penologists, and to a certain extent to cause a reaction of opinion in its favor, at least in a modified form.

The first prison in America to follow the example of Philadelphia was that at Auburn, N. Y., which adopted the Pennsylvania system in 1830, but, unlike the prison at Philadelphia, no employment was provided and in fact the cells were not of a size to permit such employment, and the result was the early abandonment of the system. In its place labor in association, by day, was provided for the prisoners, and solitary cellular confinement at night. This soon became known as the Auburn or congregate system, and is still so recognized.

The Pennsylvania system was also adopted at Sing Sing, N. Y.; at Thomaston, Me.; at Providence, R. I.; at Trenton, N. J., and the Western Penitentiary of Pennsylvania at Allegheny, but it was soon abandoned for the Auburn system in all of them, and since then the Auburn system, with various modifications, has prevailed, almost universally, in American penitentiaries.

Aside from these two systems only one other has been operated to any large extent in the United States, and that is known as the lease system, which was adopted from necessity rather than choice in nearly all of the Southern States, immediately after the war of the rebellion, but which does not exist in any Northern State except Nebraska. Upon the liberation of 4,000,000 slaves there came such a sudden and large increase of prisoners, convicted of felonies, that sufficient room for their confinement could not be found in existing prisons, and therefore, as an available and economical expedient for getting rid of them, they were leased out to the highest bidders for the term of their sentences. The lessees were to have the entire control of the prisoners under certain restrictions as to care and management, and for the privileges thus secured they were to maintain the prisoners, and pay the State a stipulated price per capita.

This system, in reality, is a modified form of slavery, but of necessity is far more dangerous and cruel than unlimited slavery, with that personal ownership in the master which makes him interested in the preservation of his property. In the nature of things it cannot last long in any civilized country, and is now rapidly passing away. In fact, the only Southern States in which no legislative action has yet been taken for the extinction of the lease system are Georgia, Florida,

Tennessee, Mississippi, Arkansas, and Louisiana, but in these there is a powerful and growing public sentiment which promises its entire and speedy termination.

Next to Pennsylvania, in point of time, the State of Massachusetts became actively interested in the reform of prisons through the organization of "The Society for the Improvement of Prison Discipline, and for the Reformation of Juvenile Offenders," at Boston, in 1815. This was the second great prison society of the world. The third was "The Royal Prison Society of France," organized in 1819; and the fourth, "The Boston Prison Discipline Society," established in 1824.

These two Massachusetts societies did an active work for many years in the education of public sentiment, and, through their influence largely, the State has kept abreast of the best experiences of the world in its methods of dealing with the criminal classes, and taken as a whole its prison and reformatory methods are not surpassed by any State in the Union, and in some respects they are in advance of all others. The prison for women at Sherborn, and the reformatory for men at Concord, are especially noteworthy, and the Suffolk county jail in Boston for many years has been a model for the nation in its enforcement of the absolute separation of all prisoners awaiting trial. The probation system for misdemeanants in force in the city of Boston has also attracted large attention among penologists, and its centralized control of prisons is worthy of imitation everywhere.

The State of New York, in its efforts for better methods of prison management, followed Pennsylvania and Massachusetts very closely, and in one respect was in advance of both of them. "The House of Refuge," opened in 1825, and still in operation at Blackwell's Island, was the first institution for juvenile delinquents in the United States, and was the outgrowth of the work of "The Society for the Prevention of Pauperism," established in 1818, and reorganized in 1823 as "The Society for the Reformation of Juvenile Delinquents." Since then New York has always maintained an advanced position in all matters pertaining to prisons and prison management.

The prison at Auburn, established in 1816, as we have already seen, created and gave its name to the congregate system, now almost universally adopted in the United States, and the reformatory prison at Elmira, established in 1877, marks a new era in prison management, and is now the model prison of the world in its methods of dealing with felons under 30 years of age convicted of their first offence. The indeterminate sentences in force at Elmira are no longer experimental, and for this class of criminals are now almost universally approved by penologists. So, also, the Elmira plan of segregating the prisoners into three classes under the mark system, together with industrial training and conditional discharges, are features of the highest value, which are being rapidly adopted elsewhere. New York was also the first State in the Union to establish a hospital, separate from its prisons, for the custody of insane criminals, which has been in operation at Auburn since 1858.

The organization of the New York Prison Association in 1844, and its continued activity since, has also exerted a wide influence in all matters pertaining to prisons, not only in the United States but in foreign countries. By the efforts of this association and its accomplished secretary, Rev. E. C. Wines, the organization of the National Prison Association was effected in 1870, and of the International Prison Congress in 1872, both of which have contributed very largely to the advancement of prison reforms, and still remain in active operation.

The State of Ohio also has taken an advanced position in prison improvements, and has in process of completion a general system of prisons upon a comprehensive plan of progressive classification, which pro-

vides jails so constructed as to secure the absolute separation of all prisoners awaiting trial (of which a score or more have already been completed), district workhouses for misdemeanants, an intermediate penitentiary for young men under thirty years of age convicted of felony for the first time (now being erected at Mansfield), and retains the old penitentiary at Columbus for life-prisoners and incorrigibles.

For delinquent children Ohio was the first State in the Union to establish reformatories upon the family or cottage system. The first was for boys, at Lancaster, in 1858, and the second, for girls, at Delaware, in 1878. Ohio has also taken the lead in establishing a system of paroles for penitentiary prisoners, and in making a third conviction for felony conclusive evidence of incorrigibility, and subjecting the offender to imprisonment for life.

During the first half of the present century the United States were clearly in advance of all other nations in prison management, but since then we have fallen behind, and other nations, having adopted all that was best in our American systems, have added large improvements of their own.

In recent years, however, through the influence largely of State boards of charities and correction, and the conferences and publications of the national and local prison associations, there has been a revival of public interest in America upon prison subjects, and annual improvements are indicated by the action of Legislatures in almost every State.

The fact that in the United States, for many years past, there has been a steady increase of crime in a ratio largely in advance of the increase of population, has also emphasized the necessity of better methods in dealing with the criminal classes, and has aroused public attention. This increase, as indicated by the U. S. census reports, is as follows:

Year.	Prisoners.	Ratio to population.
1850.....	6,737	1 out of 3,442
1860.....	19,086	1 " " 1,647
1870.....	32,901	1 " " 1,171
1880.....	58,609	1 " " 855

That this rate of increase has been checked somewhat now seems assured by reports of investigations in several States, and it is probable that the national census of 1890 will show a perceptible and possibly a large decrease in the country as a whole.

The science of penology is no longer in a chaotic condition, for its fundamental principles are as well established as those of any other science relating to social development, and their application in other countries, and notably in England, has shown that crime can be so dealt with that, instead of increasing, it can be steadily diminished. In the nature of things, preventive measures will always be more potent for good than any others, but still the necessity will always remain for intelligent treatment of those actually convicted of crime and sentenced to prison confinement. At the bottom of all effective prison management, and without which no large results in the reformation of criminals can be obtained, is such classification as will cut off, or at least minimize, the contaminating influences of evil associations.

According to the census, the number of prisoners in the United States, June 1, 1880, not including the inmates of reformatory institutions for juvenile delinquents, was 58,609. The number of juvenile delinquents reported was 11,468. The total number, therefore, of criminals and quasi-criminals, taken together, was 70,077. Of the 58,609 prisoners, properly so called, 30,659 were found in penitentiaries, 7865 in workhouses and houses of correction, 12,691 in county jails, 1166 in city prisons, 499 in military prisons, 350 in hospitals for the insane, and 4879 were leased out to private parties.

It will be noticed that of these prisoners 14,350, or

nearly one-fourth of the entire number, were in county jails and city prisons. This, however, only represents the number actually in confinement on the day of enumeration. Taking the whole year through, the number of separate prisoners actually confined in jails and city prisons would be increased at least tenfold, and possibly twentyfold; and if we include village lock-ups and city station-houses, the number would again be increased many times. It is very evident, therefore, that in the classification of prisoners, with a view to prevent the contaminating influences of association, the largest attention by far should be given to county jails and city prisons, and it is here our American prisons are most deficient. In fact, at this one vital point of unrestricted association among prisoners, our American jails are substantially the same as the jails of England were found by John Howard a century ago.

In England at the present time jails, by act of Parliament, are simply places of detention for prisoners awaiting trial, and each prisoner is kept entirely separate from every other prisoner; but in America, with very rare exceptions, prisoners in jail are herded together in a common hall, and all the evils of association are not only permitted, but enforced, so that the jail becomes a school of crime and a moral pest-house. So long as this continues all penologists are agreed that no large advance in the suppression of crime can be expected, and they are also agreed that cellular separation is the only effective remedy.

Several States are making progress in this direction, notably Massachusetts and Ohio. The Suffolk county jail, in Boston, has already been referred to as the pioneer in cellular separation, and in Ohio nearly all new jails, for several years past, have been constructed upon what is known as the central corridor or Ohio plan, which provides for the entire separation of prisoners, and in several such separation is now enforced; and a law is now under consideration by the Legislature to make it compulsory in all.

In England, by act of 1877, the control of jails was vested in a body of prison commissioners, appointed by and responsible to the Home Secretary, which secured uniformity of action throughout the kingdom, and contributed largely to the present pre-eminence of English prisons; but in the United States the control and maintenance of jails, except in Massachusetts, is entirely with county authorities, and so long as this continues progress will necessarily be slow. It is so clearly evident that jails, together with all other prisons, should be wholly under control of the State authorities, that it would only seem necessary to bring it to the attention of the public, in order to secure its adoption, but thus far local and political interests have been strong enough to prevent affirmative action.

Outside of jails and other places of detention for prisoners awaiting trial, the prisons of the United States, as a whole, are not inferior to those of other countries, either in construction or management, and many of them are keeping fairly abreast of the best experience of the world. In each of the Northern States, and in most of the Southern States, there is at least one penitentiary for prisoners convicted of felonies; and in some of the larger States there are two or three, and all of these, except the Eastern Pennsylvania Penitentiary, at Philadelphia, are conducted upon the congregate or Auburn system of management, which maintains cellular separation at night, and associated labor in silence by day.

The tendency of public sentiment in the United States now seems to favor such classification of penitentiaries as shall provide for the separate confinement of young men under thirty years of age convicted of their first offence. The first prison of this kind was established at Elmira, N. Y., and is known as the Elmira Reformatory. Its success in the reformation of prisoners has been so conspicuous that several other States have adopted the system. The reformatories at Concord, Mass., Huntingdon, Pa.,

and Mansfield, Ohio, are prisons of this kind, and similar prisons are now being constructed in Minnesota and Kansas, and are under legislative consideration in several other Western States.

The distinguishing features of the Elmira system are: (1) The Indeterminate sentence. (2) Classification of prisoners into three grades regulated by a system of merit and demerit marks. (3) Discharge upon probationary parole, under supervision. The Elmira system is distinctly a new departure in prison management, and is receiving large attention, not only in the United States but in other countries, and the general adoption of its leading features now seems probable.

There is also a growing sentiment in favor of separate prisons for women, to be entirely controlled by women. Two such prisons have been in operation for several years, one at Indianapolis, Ind., and one at Sherborn, Mass., and their advantages are so manifest that others are contemplated in several of the larger States.

In the United States there are no prisons owned and controlled by the general government, except a few territorial jails, and the military prison at Fort Leavenworth, Kas. Prisoners convicted of felonies under federal laws are confined in such State penitentiaries as may be designated by the Attorney-General of the United States, under agreements with State authorities. Of this class of prisoners 1228 were reported July 1, 1886, as serving out sentences in 55 separate prisons, in 25 States, 6 Territories, and the District of Columbia. That a great government like ours should convict its citizens of violations of its laws, and then consign them to prisons in which it has no ownership, and to the care of officials over whom it has no control, is not creditable, and attorney-generals for several years past, in their annual reports, have recommended the erection of federal prisons for all prisoners of this kind. Bills for this purpose have been considered by Congress, but no act has been passed.

The attorney-general has also recommended to Congress some action for the better care of federal prisoners awaiting trial, or serving sentences for misdemeanors, of whom there are several thousand, who are at the present time kept in the local jails of the judicial districts where the offences were committed, and are substantially outside of any federal care or supervision.

Misdemeanants.—For misdemeanants, especially, there would seem to be an imperative necessity for workhouse or reformatory care, for association in idleness, as at present, with hardened criminals in county jails, cannot be otherwise than demoralizing. For misdemeanants generally there is now large consideration among penologists on account of the apparent inefficiency of existing methods for their treatment. By the term misdemeanants is meant such persons as are convicted of offences less than felony, and are usually sentenced for short periods to jails or workhouses. As these institutions are wholly under county or city control they seldom receive that intelligent supervision or management which is essential to their highest efficiency. Penologists are substantially unanimous in the opinion that district workhouses exclusively under the control of the State should be provided for this class of prisoners, and that jails should be solely places of detention for prisoners awaiting trial.

In view of the fact that workhouse misdemeanants are largely recidivists for whom short periods of confinement have no terrors, it is also advised that sentences should be cumulative, and after a third or fourth conviction be made indefinite, with a maximum limit of five years.

In the United States, in recent years, an obstructive interference in the management of prisons has arisen from the opposition of outside labor organizations on account of the supposed injurious competition of prison labor with free labor. In a few of the Northern States this influence has been sufficiently powerful to

secure legislation entirely abolishing contract labor in prisons, and in New York by act of July, 1888, not only contract labor but all other forms of labor are practically abolished in the penal institutions of the State. This law entirely prohibits the use of machinery in prisons, and only permits handwork in the manufacture of clothing and other necessary supplies for the public institutions. This, possibly, may give employment to prisoners for a month in the year, but for the remainder of the year there seems no recourse but idleness. In the estimation of all prison experts, not only in this country but throughout the world, there can be nothing more injurious to the discipline of prisons, or to the conditions essential to the reformation of prisoners, than enforced idleness. If this kind of legislation is to prevail, and become permanent, it must follow as the night the day that American prisons will retrograde to the condition of the dark ages, and the progress of the last century will be practically lost.

That there is ground for objection to contract labor most penologists agree, and they greatly prefer some other form of labor, whenever the reformation of prisoners is a leading object, but that productive labor of some kind is an indispensable requisite to the proper conduct of convict prisons of every grade is considered by all students of penology and by all practical prison managers settled beyond all dispute. It is not likely, however, that a people as intelligent as those of New York, or of any other State, will submit for any long period of time to the taxation necessary to maintain in absolute idleness an army of criminals, and especially when they discover, as they will, that no good comes by it either to the laborers outside of the prison walls or to prisoners inside.

The total amount of prison labor in the United States, as compared with the total amount of free labor (as shown by the report of the U. S. Commissioner of Labor, for 1886), is only $\frac{1}{4}$ of 1 per cent., and therefore by the economic law which shows that wages (the price of labor) are not fixed by the number of laborers or the producing power of any single manufacturing industry, but are governed by the total number of laborers and the total production of all the industries of every kind in the country, it is absolutely certain that the abolition or retention of prison labor cannot have any appreciable effect upon the wages of free labor or the price of its products.

The concentration of all prison labor upon a few industries, doubtless, might affect, injuriously, industries of the same kind outside, and might compel their operatives to seek other employments on account of overproduction, as often occurs in other cases, but even then there would be no perceptible influence upon the general average of wages. As a matter of fact such concentration has rarely occurred to an injurious extent, and such cases could easily be corrected by legislation.

The total number of persons employed in prison industries, and the total number of free laborers in the same industries outside, is shown by the following statistics from the census reports of 1880:

Form of industry.	Total No. citizens.	Total No. convicts.	No. of convicts to 100 citizens.
Agricultural implements...	39,580	284	0.7
Bolts and rivets.....	5,064	167	3.3
Boots and shoes.....	134,256	6,358	4.7
Boxes.....	17,400	55	0.3
Brickmaking, quarrying..	66,355	1,016	1.5
Brooms and brushes.....	8,773	1,786	20.3
Buttons.....	5,825	29	0.5
Carpeting.....	21,023	304	1.4
Chairs.....	10,575	3,313	31.3
Cigars and tobacco.....	53,297	659	1.2
Clothing.....	160,813	1,291	0.8
Cooperage.....	25,973	821	3.1
Foundry and machinery...	110,351	157	0.1
Furniture.....	48,729	946	1.9
Hardware.....	17,201	215	1.2
Harness and saddlery.....	21,446	1,014	4.7

Form of industry.	Total No. citizens.	Total No. convicts.	No. of convicts to 100 citizens.
Hats	22,671	326	1.4
Hemp and jute	4,306	392	9.1
Hosiery and knitting	28,885	2,417	8.3
Lime-burning	4,570	218	4.7
Marble work	21,471	320	1.5
Printing	58,478	82	0.1
Railway cars	14,232	180	1.2
Saddlery hardware	2,815	536	19.0
Shirts and collars	25,687	684	2.6
Stoves and hollowware	35,000	1,576	4.5
Tanning	24,812	87	0.4
Tools	13,679	248	1.8
Trunks and valises	4,574	25	0.5
Wagons and carriages	46,704	1,458	3.1
Whips	1,056	130	12.3
Wire-work	4,459	208	4.6
Total	1,059,020	27,302	2.5

It appears, therefore, that only 32 industries, all told, are represented in the prisons of the United States, and that the aggregate of these industries compared with the same industries outside is only 2½ per cent. It should be remembered also that a large proportion of prisoners are employed in the same industries inside that they were previously engaged in outside, and as the product of their labor inside cannot be greater than it was outside the percentage of competition should receive corresponding reduction. The productive power of convict labor is also much less than free labor, so that the 2½ per cent. of apparent competition, small as it is, should be largely reduced. In fact, except for political purposes, it would scarcely be noticed.

As with prison labor, so also with prison administration, political influences of a partisan character have been largely injurious. In fact, to a large extent, prison officers are selected, not because of experience and trained efficiency in prison management, but because of their services in securing votes for the dominant political party, and prisons can be named in which it has been the established custom for many years that whenever a change of politics occurs in the State, all persons within the prison walls, except the prisoners, must go out, and the result is untrained officials, and terms of office so brief, as to forbid the attainment of the experience essential to the highest efficiency in prison management. Until this evil can be corrected American prisons must remain at a disadvantage in comparison with other countries.

In England the entire prison service is organized under the control of the Secretary of State for the Home Department, subject to whose orders each class of prisons is governed by central boards of directors and commissioners, and constantly examined by government inspectors and by local justices. The officers within the prisons are men who devote their lives to the work, and are appointed and promoted, paid or pensioned, solely for fitness, experience, and efficiency in the service. "Politics" are utterly without influence in the matter. Every appointment is made after a rigid examination into qualifications for the special work in hand, and then is probationary only, its continuance depending solely upon proved efficiency. Administrations, parties, and governments may rise or fall, but from the chairman of directors of convict prisons, now the highest authority in the kingdom on the subject of prison discipline, down to the humblest turnkey, every man is secure in his place while he fills it well; not one can be dislodged or fail of his fair promotion except by failure to do his work.

In France, at Metz, in connection with the agricultural penitentiary at that place, for forty years past there has been a training-school for prison officers, and M. De Metz, its veteran superintendent and the highest authority in the world upon this subject, has declared that a good penitentiary establishment is impossible which does not create a nursery of agents from which to recruit its staff. So also in Belgium and other con-

tinental countries where high attainments have been made in prison management, efficiency of administration by trained officials is considered indispensable, and without it no prison, however complete in its construction and equipment, can be a success, either there or here.

In the construction, classification, and management of prisons in the United States a greater advance has been made in the last decade than in the previous quarter of a century. The discussions and interchange of experiences among penologists at national and international conferences have brought about an intelligent consensus of opinion which has had a large influence for good, not only in prison management but also in legislation pertaining to prisons, and there is every reason to hope that in the near future a still larger and more general advance will be made in all our methods of dealing with the criminal classes.

As to the character of these improvements there is now, substantially, no difference of opinion among American penologists, and their leading requirements may be briefly summarized as follows:

1. County jails should be solely places for the detention of prisoners awaiting trial, and in them no prisoner should be permitted to associate with any other prisoner.

2. Prisoners convicted of misdemeanors should be sent to district workhouses and employed at productive labor.

3. Prisoners convicted of felony should be sent to penitentiaries, of which there should be at least two in each State—one a reformatory for young men, and the other for life-prisoners and incorrigibles, and no prison should contain a population exceeding 1000, and a reformatory not more than 600.

4. All sentences, except for life, should be indefinite, subject to parole and police supervision within a minimum and maximum limit.

5. All able-bodied prisoners should be kept at productive labor, but those in reformatories should receive such educational and industrial training as will enable them to earn an honest living after discharge.

6. All prisoners upon discharge should be systematically aided to obtain employment.

7. Prisoners convicted more than twice for felony should be adjudged incorrigible, and sentenced for life, or at least for long periods, with the privilege of parole for good conduct at the maximum limit of a first conviction.

8. Prison officers should be as thoroughly trained for their duties as are army and navy officers, and their tenure of office should be as secure and their compensation as liberal.

9. Prisoners convicted of violations of federal laws should be confined in prisons owned and controlled by the general government.

10. In all prisons moral and religious culture should be the leading reformatory influences, and a prison school, with competent instructors, should be an indispensable requirement. (R. B.)

PRIVATEERING is the practice of sailing armed vessels owned and officered by private persons, but acting under a commission from a state, which authorizes them to cruise against the commerce of an enemy.

Such commission is usually called a "letter of marque," the term being derived from a procedure upon land, granting license to go across the boundary ("mark") and make reprisals. A privateer corresponds to a troop on land commanded by private parties, but acting under authority of the state, rather than as a guerilla band. A privateer without a license from the state would be liable to the charge of piracy. The use of privateers in Europe dates back to the time when large public navies had not been formed. During the Middle Ages the European states without navies impressed merchant vessels in time of war. Private parties also engaged in warfare upon the high seas in

their own vessels or at the public expense. There were also free plunderers, who hired public vessels and sailed them with crews and outfits of their own, the expedition of the French against the Portuguese at Rio Janeiro, in the reign of Louis XIV., being an example. It was toward the end of the sixteenth century, in the middle of the war in the Netherlands, that letters of marque began to be issued. William of Orange appears to have used this method, and he was met in retaliation by the Spanish government. The French adopted privateering about 1555.

The advantage of privateering on the side of a nation with a small navy, when it is at war with a nation having a large commercial marine, is very evident. The United States had this advantage during the war of the American Revolution, yet Benjamin Franklin, in his correspondence with the British authorities, declared that though the practice of privateering may be incidentally beneficial, yet "it is a remnant of piracy, and is far from being profitable to all engaged in it or to the nation that authorizes it." He claimed that farmers, fishermen, and merchants should not be molested by enemies even in times of war; and his doctrine was incorporated in the treaty of 1785 between the United States and Prussia, which he fashioned. This treaty provided that neither of the contracting parties should issue any commission to any private armed vessels against the other, empowering them to take or destroy its trading vessels, or to interrupt commerce. When this treaty expired, in 1799, this article was not renewed. Had it been renewed, and had Great Britain and the United States agreed to the same, it would have been a fortunate thing for the former power in the war of 1812, and for the latter in the civil war of 1861. Thomas Jefferson is known to have approved of the practice of privateering, and to his influence may be attributed much of the privateering carried on by Americans in the war of 1812. During the war of the Revolution the people of the United States had engaged in the practice in but a small degree, except toward the latter end. New London, Conn., became head-quarters for the privateers, and this fact afforded an excuse to the British for burning it in September, 1781. The Legislative Assembly of France in 1792 proposed that all nations should do without privateering, but not one of them adopted the suggestion.

The war of 1812, the second between Great Britain and the United States, proved the opportunity of the Americans to prey upon British commerce. Congress declared war June 18, 1812, but 75 days before that date there was a list of 18 privateers already fitted out at Baltimore, and by October 15 there were 26 from New York. The first British ship was captured July 1, and by July 14 it is said that there were at least 65 privateers at sea. In November the owners of 24 privateers from New York petitioned Congress to reduce the duties on prizes, and to allow captors to dispose of such prizes. The first privateers of this war carried less than 10 guns, but later from 20 to 30 guns were carried. It is stated that a contract was made in Boston for the building of a privateer in 18 working days. The estimate is that within 2 years more than 800 British vessels were captured. The list of American privateers numbered 250 in all, of which 58 were from Baltimore, 55 from New York, 40 from Salem, Mass., 32 from Boston, and 14 from Philadelphia. At the opening of the war the effective force of the American navy consisted of only 7 frigates, with a total of 278 guns.

In 1818 Congress passed a law forbidding the enlistment, within the United States, of any person on board of any privateer belonging to a foreign power. In 1824 the United States urged upon Great Britain the abolition of privateering, but that entreaty was not heeded. Thirty years later, in 1854, Lord Clarendon advised such abolition. James Buchanan, then the ambassador of the United States at the court of St.

James, replied that this would not be satisfactory unless all the naval powers should agree that war should not be waged against private property on the high seas, in the same way that it had been already agreed that war should not be waged against private property on land. While the law of 1818 was very strict in forbidding American citizens to enter the service of foreign privateers, yet the United States, according to Buchanan's statement, could not agree that it would not use its merchantmen in case of war.

A very important step toward the entire abolition of privateering was taken at the treaty of Paris in 1856. This treaty contained four points relating to privateering, which it was agreed should be regarded as an entirety. These points were to bind only those states assenting, and it was the understanding that those states signing would try to secure the signatures of other states not represented. The four points were as follows: "1. Privateering is and remains abolished. 2. The neutral flag covers enemy's goods, with the exception of contraband of war. 3. Neutral goods, with the exception of contraband of war, are not liable to capture under an enemy's flag. 4. Blockades, in order to be binding, must be effective; that is to say, maintained by a force sufficient really to prevent access to the coast of an enemy." Nearly all of the secondary states of Europe and America signed the treaty. The United States, through W. L. Marey, then Secretary of State, refused to sign, but declared that the treaty would be signed "in case the clause abolishing privateering were amended by adding that the private property of the subject or citizen of a belligerent on the high seas should be exempted from seizure by public armed vessels of the other belligerent, except it be contraband of war." The great powers refused to allow this change. When the civil war of 1861 broke out the U. S. government found itself in a very difficult position on this account. W. H. Seward, then Secretary of State, offered the assent of the United States to the treaty of Paris without the amendment noted above; but this was declined by the governments of Great Britain and France if coupled with the condition that it was to be made applicable to the use of privateers by the Confederate States.

Pres. Lincoln's proclamation of April 15, 1861, calling for 75,000 men to put down the insurrection and to repossess the ports, was answered by the granting of letters of marque and reprisal by the Confederate States. Lincoln then, April 19, declared a blockade of all the Southern ports, and threatened the Confederate privateers with punishment for piracy. A long debate took place in the British House of Lords in May and the ground taken by the President was strongly denounced. Finally, England declared that no Confederate prizes should be carried to the British ports. The French declared that privateers might enter their ports with prizes which they could not sell, and that such privateers should remain only 24 hours. The Spanish government enacted a similar requirement. The recognition of the Confederate States as belligerents by the British government was a severe blow to the U. S. government, for the latter was very poorly prepared to show that the blockade was an effective one. The Confederates followed up their advantage by threatening retaliation in case the captured crew of the privateer Savannah were treated as pirates. The trial found the court in doubt as to whether the U. S. government could treat as pirates those of its own citizens who were alleged traitors against it, and so the case fell to the ground. This left the seas open to the Confederate privateers, and the opportunity was eagerly seized. Swift steamers, like the Sunter, Nashville, and Alabama, preyed upon the American commerce.

For years after the end of the civil war the U. S. government sought compensation from Great Britain on the ground that the latter had allowed the escape of the privateers from British ports. In 1871 the

treaty of Washington provided for the settlement of several disputes between these governments, the chief of which referred to those demands known as the Alabama Claims (*q. v.*). The commission met in December, 1871, at Geneva, and, after a hearing of 9 months, agreed upon the "Geneva award." By its terms \$15,500,000 in gold were paid by Great Britain to the United States for the satisfaction of the claims referred to the consideration of the tribunal. Congress subsequently constituted a court to take charge of the Alabama Claims, which court has but recently (1888) completed its business. According to the present agreements between the leading nations of the world, there is no probability that any war hereafter will be attended by such acts of privateering as have been frequent in the past. (F. G. M.)

PRJEWALSKI, NICHOLAS VON (1830-1888), Russian explorer, was born March 31, 1830, at Smolensk. Educated at the Military Academy in St. Petersburg, he became instructor in history at Warsaw. In 1867, at his own request, he was sent to East Siberia, where he spent two years. Then he journeyed southward to the Yangtsekiang, and thence northward, crossing the Desert of Gobi on his way to Irkutsk, which he reached in October, 1873. In his next expedition, 1876-77, he explored Lob-Nor, and the Altyn-Tag Mountains. In 1879 he crossed into Thibet, and had approached within 120 miles of Lassa when he was obliged to turn off towards the Hoangho, and thence back to Orenburg. In 1883 he again crossed the Desert of Gobi, discovered the sources of the Hoangho, and again reached the Yangtsekiang and Lob-Nor in 1885. He gathered a vast zoological collection, containing over 500 reptiles and 5000 birds. He held the rank of colonel in the Russian general staff. His explorations have been published by the Russian Geographical Society, but he also published *Journeys among the Mongols and in the Deserts of North Thibet*, 1870-73 (1875-76); *Journeys in Thibet*, 1875-80 (1883). His travels were translated into English, and the geographical results given in the *Proceedings of the Royal Geographical Society* (London, 1887). He died in Central Asia in 1888.

PROCTOR, RICHARD ANTHONY (1837-1888), astronomer, was born at Chelsea, Eng., March 23, 1837. He was educated at King's College, London, and St. John's College, Cambridge, and graduated B. A. in 1860. He devoted himself to astronomical labors, and from his analysis of the researches of the Herschels, Struve, and others, as well as his own, he formed a new theory of the stellar universe. For a time he was a member of the Roman Catholic Church, but he left it in 1875 on the ground that certain of his scientific views were incompatible with its faith. Proctor was a most industrious writer and lecturer, but never held a really prominent position among scientists. He was made fellow of the Royal Astronomical Society in 1866, and was its honorary secretary for a few months in 1872. He spent the winters of 1873-74 and 1875-76 in lecturing tours in the United States. In 1881 he took up his residence at St. Joseph, Mo., having married as his second wife a lady of that city, and he was naturalized as an American citizen. In 1887 he removed to Marion co., Florida, where he began to build an observatory. He died suddenly on Sept. 12, 1888, at New York, having come thither on his way to Europe, where he was to lecture. His principal works are *Saturn and its System* (1865); *Gnomonic Star Atlas*, recording 324,000 stars (1866); *Constellation Seasons* (1867); *Half-hours with the Telescope* (1868); *Half-hours with Stars* (1869); *Other Worlds than Ours*, with a star-atlas (1870); *The Sun* (1871); *The Moon* (1873); *Transits of Venus* (1874); *Treatise on the Cyclonid and Cyclonid Curves* (1878). He also published an interesting pamphlet on *Whist*, and contributed largely to periodicals, besides editing *Knowledge*, a weekly journal. At the time of his death an elaborate work, *The Old and New Astronomy*, was in

course of publication. Proctor's labor was spent in diffusing among the people a general, though not exact, knowledge of astronomy, and in awakening interest in its researches. His successive works combined theory with ascertained facts, and discussed them in such a way as steadily to diminish his reputation with practical astronomers.

PROHIBITION PARTY. This party received its national organization by a convention of nearly 500 delegates from twenty States and the District of Columbia, assembled in Farwell Hall, Chicago, Ill., Sept. 1, 1869. The convention continued its sessions during two days. The call was issued by a committee of those favoring independent political action during the session of the R. W. Grand Lodge of Good Templars, held in Oswego, N. Y., in the month of May previous. The committee consisted of James Black, of Lancaster, Pa.; Prof. Daniel Wilkins, of Bloomington, Ill.; John N. Stearns, of New York city; Julius A. Spencer, of Cleveland, O., and John Russell, of Detroit, Mich. When the convention assembled Mr. D. R. Pershing, of Indiana, called the meeting to order, read the call, and nominated Rev. John Russell, of Michigan, as temporary chairman. On taking the chair Mr. Russell, among other things, said: "The people who fear God and regard the social and moral welfare of their fellow-men are, in all parts of the country, beginning to realize the imperious necessity for some stronger and more formal bond of union between those who favor legal prohibition of the liquor traffic. While separated by other political party lines, and absorbed in other issues, we are unable to act efficiently together for what we conscientiously believe to be the most important moral and political movement of the age. Hence, the object of our meeting is the organization of a separate and independent political party, presenting complete legal prohibition of the manufacture and sale of alcoholic drinks as its paramount issue." These sentiments were heartily applauded by the convention. Upon request of the chairman, Rev. Dr. Evarts invoked the divine blessing. After the appointment of secretaries and the usual committees, Hon. James Black, of Pennsylvania, was chosen permanent president, together with a vice-president from each of the States represented.

The committee on platform and resolutions was appointed as follows: Rev. J. C. Stoughton, of Illinois; Rev. John Russell, of Michigan; Henry D. Cushing, of Massachusetts; D. R. Pershing, of Indiana; L. B. Haines, of Ohio; Dr. S. W. Wilson, of Wisconsin; O. K. Harris, of District of Columbia; Timothy Parsons, of Missouri; M. D. Bartlett, of Minnesota; E. C. Judson, of California; Dr. Chas. Jewett, of Tennessee; Rev. J. H. Chase, of Vermont; Rev. Wm. Goodell, of Connecticut; Frank Walker, of Iowa; Hon. Gerritt Smith, of New York; S. B. Ransom, of New Jersey, and Hon. Robt. M. Foust, of Pennsylvania. A preamble and six resolutions were presented, carefully considered, and adopted as a platform. The second resolve, expressive of the chief intention of the party, is as follows: "That the traffic in intoxicating beverage is a dishonor to Christian civilization, inimical to the best interests of society, a political wrong of unequalled enormity, subversive of the ordinary objects of government, not capable of being regulated or restrained by any system of license whatever; but imperatively demands for its suppression effective legal prohibition, by both State and national legislation."

Previous to this convention, however, the question had been tentatively discussed in temperance societies, lectures, and in newspapers, and initiative local organizations had been effected in several of the States. Michigan led the way by a small convention of about forty persons, held in the city of Detroit, Jan. 8, 1867. As there was no political canvass at the time this meeting simply declared by resolution in favor of a separate party, and appointed a State committee au-

thorized to call future conventions. Illinois followed by a much larger assemblage, of some 200 delegates, at Bloomington, Dec. 9, 1868. And to Ohio belongs the honor of placing the first State ticket in nomination for a convention held at Mansfield, July 14, 1869. For this ticket 679 votes were cast in that State.

The following is the opening sentence of a call for the first national nominating convention, issued Dec. 9, 1871, and signed by John Russell, chairman, and Gideon T. Stewart, secretary: "The friends of the National Prohibition party are hereby requested to assemble in national convention at the city of Columbus, O., on the 22d day of February, 1872, at 11 A. M., for the purpose of putting in nomination candidates for the offices of President and Vice-President of the United States, to be supported at the next ensuing national election; and of transacting such other business as the convention, when assembled, shall deem advisable." At the convention, assembled pursuant to the above call, Hon. Henry Fish, of Michigan, was chosen temporary chairman, and subsequently Hon. S. B. Chase, of Pennsylvania, was elected to preside permanently over the deliberations. Prof. Elroy M. Avery, of Ohio, was elected secretary, with Capt. Chas. P. Russell, and several other assistants.

This convention adopted a broad platform consisting of a preamble and 17 resolutions on various subjects; the two subjects of chief importance which received unequivocal endorsement were the complete legal outlawry of the liquor traffic, and impartial, yet properly qualified, suffrage, without distinction of "sex or race." Hon. James Black, of Pennsylvania, received the nomination for the Presidency, and Rev. John Russell, of Michigan, for the Vice-Presidency, at the hands of this convention. For this ticket there were cast a total of 5508 votes, in six States—Connecticut, Michigan, New Hampshire, New York, Ohio, and Pennsylvania.

The second national nominating convention met in the city of Cleveland, O., May 17, 1876. Rev. H. A. Thompson, D. D., of Ohio, presided, and Charles P. Russell, of Michigan, was secretary. Hon. Green Clay Smith, of Kentucky, was made the nominee for the Presidency, and Hon. G. T. Stewart, of Ohio, for the Vice-Presidency. The platform of 1872 was reaffirmed, and 15 new resolutions were adopted. This year there were cast 9757 votes for the Presidential ticket by 17 States.

On June 17, 1880, the party held its third nominating convention, again at Cleveland, O., and Rev. A. A. Miner, D. D., of Boston, Mass., presided. Gen. Neal Dow, of Maine, was unanimously chosen as Presidential candidate, and for Vice-Presidential nominee Rev. H. A. Thompson, of Ohio, was selected. The ticket received 11,610 votes.

The great social and semi-religious temperance revival which spread over the country during the previous decade had by 1881 fairly crystallized into its logical sequence of prohibition sentiment. But many of the more active new workers now in the field were but imperfectly informed regarding the real status of the Prohibition party. Hence, at a convocation composed chiefly of such new recruits, held at Lake Bluff, Ill., in August, 1881, an organization known as the "Home Protection Party" was effected. However, at a subsequent conference, convened at Chicago Aug. 23, 24, 1882, composed of 341 delegates, there was little trouble in effecting a union of the two organizations under the name of "Prohibition Home Protection Party." Even this change of title lasted only two years, when the original name of "Prohibition Party" was restored by a vote of the next national nominating convention, which was held in Pittsburg, Pa., July 25, 1884.

This convention marked a bright era in the history of the party. There were 602 delegates present. The platform, although newly constructed in form, was not essentially changed in sentiment. Prof. Samuel

Dickie, of Michigan, was selected to preside over the deliberations. Ex-Gov. John P. St. John, of Kansas, received the nomination for the Presidency, and Hon. William Daniel, of Maryland, for the Vice-Presidency. More than 150,000 votes were cast for this ticket in the nation. The late Hon. John B. Finch was made chairman of the national committee, and infused new life and force into the operations of the party.

After the death of Mr. Finch, which occurred Oct. 3, 1887, the present incumbent, Prof. Samuel Dickie, of Michigan, was called to that position.

The fifth national convention, held at the city of Indianapolis, Ind., on May 30, 31, 1888, composed of 1046 delegates, nominated Gen. Clinton B. Fisk, of New Jersey, as its candidate for the Presidency, and Rev. Dr. John A. Brooks, of Missouri, for the Vice-Presidency. It is reckoned that 242,984 votes were polled for the ticket, being about 100,000 more than were cast for the party in 1884.

The comparatively slow progress of the movement is a source of discouragement to persons of sanguine temperament. But patience is an essential virtue in a reformer. Drunkenness and its adjunct, the liquor traffic, constitute a chronic disease of the body-politic. Such difficulties yield but slowly even to the best of treatment. Prohibitionists regard the temperance reform as a complex question, both social and political. In its legal relations it is strictly a political measure, demanded by strong moral considerations. The legalized liquor traffic is a counter-educating and counter-acting force, standing directly in the way of all moral efforts to save society from the direful consequences of using alcoholic intoxicants.

License or taxation provides for the regulation and continuance of the business, but not for its suppression. Prohibition is the only line of policy which aims logically at, and seriously contemplates the utter overthrow of, the dram-shop system. Therefore the paramount issue which the Prohibition party presents is, "Prohibition versus Legalization of the Liquor Traffic." They indict the business of making and vending intoxicating beverages as grossly immoral in its nature and tendencies, in violation of the sound principles of political economy, and at variance with every object of good government, constituting a political wrong of unequalled enormity. For this "gigantic crime of crimes" absolute prohibition is the only adequate remedy, to secure which involves the responsible agency of a political party.

They regard the nation as being again confronted with the solution of a great public question, which is of so radical a nature as to be utterly incapable of any just compromise. The question is not whether we shall have a few saloons or many, but whether we shall have any or none at all. Only such a condition can justify the formation of a new political party in this country, but when such a political question does present itself for settlement, there is no other way out of the difficulty.

Postulating, as somewhat axiomatic, that "Government by the people involves government through parties," and that "political parties are either strong or weak to handle public questions in proportion as the members are united or divided on the particular question to be adjusted," the main argument against the older parties and in favor of the new may be placed in syllogistic form thus: Where the members of a political party are radically and irreconcilably divided on any question, it thereby becomes impossible for the party to give positive and effective legislation on that question. But members of the two leading parties are radically and irreconcilably divided on the question of prohibiting the liquor traffic. Therefore, it is impossible for either of them to give positive and effective prohibition of the liquor traffic. Hence the need and existence of the radical Prohibition Party. (J. R.)

PRONGHORN, or PRONGBUCK. See ANTELOPE, AMERICAN.

PROPERTY. Property consists of material things, and rights growing out of such things, to and of which one has the exclusive right and possession. The earliest division of property known to the English law was into "real" and "personal." So far as the subject matter is concerned, real property includes land, minerals in it, what is grown or built upon it, and certain rights which are connected with or issue out of it. All other forms of property whatsoever are personal.

REAL PROPERTY.

The law governing real property was developed under the feudal system. The theory of this system was that the king was the absolute owner of all the land in the kingdom and granted portions of it to certain of his subjects who, in turn, subdivided their respective shares and granted portions to others. What was conveyed by these grants, however, was not the land itself but an interest or an estate in the land, and therefore every one who held land, except the king, was called a tenant because he held under some superior lord, and all held, finally, either mediately or immediately, of the king, who was the lord paramount. The interest in land which a subject had was called his estate.

All subjects held their lands feudally; that is, under some superior to whom they were bound to render allegiance and service in return for the land; the king held allodially; that is, he held the land itself, and was under no obligations to any superior.

The tenure by which these tenants, if they were freemen, generally held the land was upon condition of performing military service; of following their lord to the war and furnishing from among their retainers a certain number of armed men. The tenant also swore allegiance to his lord and promised to be subject to his commands. If the tenant was not a freeman the services he rendered were of some menial kind.

There were certain incidents connected with this military tenure. The tenant was bound to ransom his lord if he was captured; to pay the expense of making his lord's eldest son a knight; to give his eldest daughter a marriage portion. He was also bound to pay for the privilege of being his lord's tenant. The lord was entitled to the wardship of his tenant's heir if he was a minor. The tenant was obliged to pay for the privilege of transferring his estate, and, by reason of the lord's superior title, the land reverted to him when the tenant died and left no heirs.

As these military tenures became vexatious on account of the uncertainty of the amount and time of service which the tenant was to render, they were all changed, in the reign of Charles II., into what was called tenure by free and common socage, when the military feature was abolished and the service upon which the estate was held was of some certain and honorable nature, as payment of money, or performance of some work or duty, to the lord. This tenure was still feudal in its nature and had many of the incidents of military tenure, but the amounts or fines to be paid were fixed by statute, and the service was rendered less onerous.

This socage tenure, as it is called, is probably the one under which lands in this country were held under the English grants. Every acre, as it has been said, was held either mediately or immediately of the king. By the Revolution the sovereign, proprietary, and territorial rights of the crown of Great Britain passed to the people of the various colonies. As the people of each colony took the place of the former sovereign, and the social condition which grew up was entirely different in its structure from the old order, the superior lords disappeared, and most of the incidents of the feudal tenure fell into disuse. Whether the holding of lands in the United States is feudal or allodial is a question about which the opinions of jurists of equal eminence differ. No State, it is believed, ever asserted

the claims of tenure and fealty from its citizens by reason of their holding of land. Some States have rejected the existence of tenure and fealty; and others have, by statute, abolished feudal tenure. Some of the courts of last resort have declared that lands are held allodially. Perhaps the true view is, that while the nomenclature of real-estate law and the forms of conveyancing still suggest some traces of feudal tenure, lands are actually held as nearly allodially as they can be when the holders are members of society under any form of government. Allegiance of the citizen to the government is still obligatory, but is independent of the holding of real estate. And the claims of eminent domain and escheat are not put upon the ground of any superior title in the government, but are enforced by reason of the agreement and consent of the citizens.

Land titles in parts of this country—as Louisiana and some of the South-western Territories—are derived from the civil, and not from English common, law. The nature of the estates, and the rights and obligations of their owners, are, however, essentially the same for all practical purposes at present under either system.

The interest which a man has in lands is still called his estate, and may be of greater or less duration. Under the feudal system a man could not have possession of the soil unless he had a freehold estate, which was defined to be "the possession of the soil by a freeman." This did not mean the unqualified and absolute ownership of the land, but the possession of it under the superior rights and title of his lord, as distinguished from the mere right to use the soil. Under the artificial system of the English law it was thought a freeman could not have the possession of the soil for a less period than his life—a freehold estate came to be an estate for life at least; and so now the smallest estate in real property is an estate for life, and a freehold is either an estate for life or a greater interest. An estate for life may be created to last either during the life of the person to whom it is granted or during the life of some other person. In either case its existence is measured by a life, and the rights of the owner are limited to that period; he cannot sell a larger interest than he possesses, nor can he dispose of it by will. At the expiration of the life the estate ceases to exist. A life-estate may be created by deed or will or by operation of law. Upon the death of a husband or wife the law gives to the survivor an estate for life in the lands of the decedent. What portion of the decedent's estate shall go to the survivors is generally fixed by the intestate laws of the different States. The homestead estate is an interest in lands which is created by statute in most of the United States. Its general incidents are similar to those of a life-estate, although it sometimes continues after the death of the husband for the benefit of the wife during widowhood, or of the minor children. This interest is intended for the benefit and support of the family, and is therefore allowed to a householder, who is also the head of a family, or to the widow and minor children. Sometimes, however, it is allowed to any householder, although unmarried. It cannot be taken in execution for the owner's debts, and its disposal is generally restrained so far as not to allow the object for which it is created, that is, the support of the family, to be defeated.

The largest freehold known to the law is an estate in fee-simple, which is created by granting or devising land to one and his heirs forever. This interest is without end. The owner may change, but the estate will not diminish. The then owner may grant or devise out of his fee-simple a smaller estate, as for life, to another person, but at the expiration of this life-estate the fee will return to the owner, or those who then represent him; or he may, by selling his fee, give to the purchaser the same unending interest that he possessed. He may dispose of his entire interest by will, subject to the rights of his surviving wife and to special statutory limitations peculiar to individual States, and, if he die without a will, his estate will

seek for his heir to the remotest degree of relationship.

An interest which is smaller than a life-estate or freehold is an estate for a term of years, or the usual tenancy, as it is generally understood. The tenant has not the possession of the soil, but only the use of the land. Of so much dignity and value did the old law esteem the freehold that an estate for even a period of years very much longer than an ordinary life was considered of less importance. And this theoretical distinction is still observed. This estate is in some respects peculiar, for while the property is itself land, the interest of the tenant, being less than a freehold, is personal property and not real estate, and, at the same time, as to most of his obligations in respect of his property, to all persons except his landlord he is held responsible practically as the owner of the land. The mutual rights and duties of the tenant and his landlord are generally regulated by contract between them, but, in the absence of any agreement, they are governed by the rules of law usually applicable to real property. The disposition of the estate, if the tenant dies before the expiration of his term, is governed by the rules which regulate personal property, and not those which control the descent of realty.

An estate may be created to begin or end upon the happening, or not happening, of some event, and, in this case, it is said to depend upon a condition. Most of the cases where real estate is given as security for debt are conditional estates; that is, an estate granted upon condition that it shall cease when the debt is paid.

The whole of an estate may be granted or devised to one person, or it may be divided into portions for successive periods, and each be given to a different individual. So a fee-simple may be carved up so as to take out of it several smaller estates before the final vesting in possession of the fee. As, however, the policy of the law is against any restraint upon the freedom of alienation, the limit of time within which these smaller estates may be created is generally regulated by statute.

A person may have certain rights in the land of another, and these are regarded as interests in real estate. A man may acquire the right of way over the land of another person; and adjoining owners have certain mutual rights of support in the houses or lands of each other.

An interest in land may be divided into a legal and an equitable estate, and the owner of each has his own special enjoyment and rights. This is accomplished by giving the legal estate to one as trustee for another; the latter is said to have the equitable estate.

The trustee is possessed of whatever extent of interest is necessary to enable him to carry out the provisions of the trust, and his management of the estate is intended to be for the benefit of the person for whom he holds it. The interests of the beneficiaries, or equitable owners, and whatever rights of enjoyment or disposal they have, are usually defined by the terms of the instrument which creates the trust. These estates are created for a great variety of purposes; frequently for the benefit of some one who, on account of some disability, cannot hold the legal estate, or for some improvident person who would squander the estate if he had full control, but for whose support some provision is desired. They are also created in order to preserve the estate intact for the person who is to be finally entitled to it, while the income is to be distributed to different individuals for a period of years, or one or more lives. The duty of the trustee is to hold and manage the estate, and distribute the income as the trust directs. To make a good trust the trustee must have some actual duties to perform; if he is made the depository simply of the legal title, the law will strike down the trust and vest the legal as well as the equitable estate in the person who is entitled to the latter. When the purposes of the trust have been

accomplished, and the equitable estate vests in those who are finally entitled to it, the trust dies out, and the legal and equitable estates merge in the same owner.

The owner of an estate may be one individual, or several who are joint owners. These joint owners may have the same quantity of interest, and hold by the same title, and acquire their estate at the same time; or they may have simply one possession of the same piece of property but for different interests—as one for life, the other in fee—and they may have acquired their titles at different times.

The extent of the owner's enjoyment in, and right of disposal of, his estate depends upon the extent of his interest in the land. The right of disposal by will is, however, restricted by statutory regulations, in many of the States, in two directions: first, in fixing at what period of time before the death a devise or grant for charitable uses can be made; and second, what share of the estate cannot be devised but must be left for the decedent's family. Subject to these limitations, he has, generally, the right to do as he pleases with his own property, provided he does not injure the rights of others in the same property or infringe upon the rights of the use and enjoyment of his neighbors in their possessions.

It is a general rule in this country that real estate is liable for the payment of the debts of its owner. A creditor can, by legal process, put his debt in such a position that it becomes a lien, under statutory limitations as to time, etc., upon the real estate of his debtor, and when this is done, a transfer of the property by the owner will convey it subject to this lien. Real estate is also liable to be taken by the government, either by taxation or under the right of eminent domain. This latter right, however, is subject to the conditions that it can be taken for the *public benefit* only, and upon due compensation to the owner.

Title to real estate is defined by Blackstone to be "the means whereby a man cometh to the just possession of his property." Where the right of possession, the right of property, and actual possession exist in the same person, he has a perfect title. Title may be acquired by occupancy. This is the taking possession of land which has no owner, or the taking possession of land which belongs to another and holding the same adversely to the title of the real owner. It may also be acquired by the act of the parties, as by gift or sale—and this, in the case of real estate, must be by a deed—or by will; or by the operation of law, as by a judicial sale, a sale under legal proceedings, or by forfeiture; or by descent, where the law casts the property upon whomsoever it designates to be entitled to it, in case the owner dies without a will; or by escheat, which is a proceeding by which the title to lands, where the owner dies without any heirs, becomes vested in the commonwealth.

PERSONAL PROPERTY.

Personal property includes every species of property that is not real estate, or an estate in land. To understand what this expression means it is necessary to recall what the old law designated an "estate in land," to wit, the possession of the soil by a freeman. As the smallest estate of freehold was the life-estate, any interest which was less than this in value or dignity was simply personal estate. The word "estate" does not fairly express the owner's interest in reference to personal property. For "estate" meant his interest in land, whereas in the case of personalty the owner possessed not an "interest" in it, but the very thing itself. The property is designated as "personal" because, unlike land which has a fixed location and is immovable, this can accompany its owner's person wherever he goes, subject only to the limitation inherent in the particular case. After the possession of the soil, the next interest in it is the

See Vol. XVIII. p. 664 (p. 677 Am. Rep.).

right to use it for a certain time. As, therefore, personal property includes, as to its subject-matter, both land and other things, the first division of it is into chattels real, including every interest in land less than a freehold; and chattels personal, all other things whatsoever. Chattels personal are said to include things in possession and things in action; and by the latter is meant the right to sue, as for the recovery of a debt. This division is incomplete, for there is a right to sue for a specific thing when one has been deprived of it; and, on the other hand, there are certain species of intangible property which imply more than a right to sue, as one's interest in a partnership or in the stock of a company. A more accurate division of chattels personal would be into things corporeal, including all tangible, visible property; and things incorporeal, or all property which is not tangible and visible. Property may pass or be changed from one species into another. Crops and minerals, when not separate from the land, are part of it, but by severance become personal property; and lumber which is used for the construction of a dwelling becomes part of the realty. Gold, which is realty before it is mined, becomes by severance a corporeal chattel, the ownership of which is lost by a loan of the money coined from the gold, and in its place the lender has simply the incorporeal property, the debt for which he may sue. In animals that are wild by nature one has a qualified property so long as they remain upon his premises.

Certain kinds of property lie along the border line between realty and personalty. These are things which, from their nature, would be considered personal property, but, by reason of their connection with land, pass as part of the realty. Heirlooms, as family pictures, armor, title-deeds, are strictly chattels, but as formerly their importance consisted principally in their connection with the land, they were considered part of the inheritance and, at the death of the owner, would go with the land to the heir and not to the executor as personal property. They are of little importance in this country, as title-deeds are generally recorded, and, under the various intestate laws, there is less distinction than formerly between the heir and those who are entitled to the personal estate. Emblements, or the products of the soil, may be realty or personalty. The question as to which they are is of importance chiefly between the landlord and the tenant upon the termination of a tenancy. Fixtures, also, are personal chattels which are attached to the land. Whether these are strictly chattels or become part of the realty are questions of great importance in transactions that may arise between a seller and purchaser of land, or between the heir and executor of the deceased owner of land; or between a mortgagee who has loaned money upon the security of premises used as a mill or factory, etc., and the creditor of the mortgagor who is seeking satisfaction out of the personal property of his debtor; or between a landlord and tenant when the dispute is as to what things the latter has the right to remove at the expiration of his tenancy. In determining these respective rights, great attention was formerly paid to the manner of the connection of the chattel to the land, the rule being that whatever was built into the land, including the buildings, became part of it and belonged to the owner of the realty. But now greater stress is laid upon the intention of the parties and the use for which the fixture was intended, and very little upon the nature of the physical connection. The leaning is strongly in favor of allowing the tenant to remove all fixtures placed upon the premises by him for the purpose of his trade.

Among many of the most valuable species of property in modern times are incorporeal chattels, as stock in corporations, or patent- or copy-rights.

Ownership in chattels may be transferred either by delivery of the chattel itself, or by delivery of that

which is evidence of its ownership. Personalty has also some of the incidents of realty. A chattel may be owned by one person, or by several as joint owners. Interests, analogous to present and future estates in realty, may be created in chattels. This, of course, is true generally of chattels not intended for immediate consumption or which are perishable, but especially of those which yield an income. The chattel may be given to one for a term of years, or for life, and, upon the termination of this interest to another. Chattels are frequently the subjects of deeds of trust. The same general rules against creating perpetuities apply in case of chattels as in realty.

There is a difference between land and personalty in the rules of law which govern each. Land has a fixed locality, and the rules of law which control it are those of the jurisdiction in which it lies, no matter what may be the domicile of the owner, while the law which controls personal property is, generally, that of the domicile of its owner. While this is generally true, there are some exceptions to it; as, in the case of the transfer of stock, the manner of doing this may be regulated by the law of the jurisdiction of the corporation, although that might not be the holder's domicile.

Title, which is the true foundation of ownership, may, in the case of personal property, be acquired by occupancy; by the act of the parties; by the act of the law. Possession is evidence of title, but not complete. A perfect title is where possession and the right of possession are in the same person.

Occupancy is the taking possession of a chattel which belonged to no one, with the intention of appropriating it. One may acquire title to a chattel which has no owner by taking possession of it as his own, or by finding a lost chattel, to which the finder has title against all the world except the real owner. Title is acquired in this way, also, to the increase of animals, the offspring being the property of the owner of the female; and also to the products of the exertions of one's brain, as his inventions.

Title by the act of the parties is by gift, where a chattel is voluntarily transferred from one to another; or by sale or exchange, where the property is transferred for a price, or for some other article; or by will. Title by the operation of the law is where the property is transferred by a judicial sale, as upon execution for the payment of a debt; or by the intestate law when the owner dies without a will. In many States the personal property of one who dies intestate and without leaving any known person who may be entitled to his property under the statutes of distribution is vested in the commonwealth by process of escheat.

LITERARY PROPERTY.

It seems to be agreed that the right to property is founded upon occupancy, or first possession. "Occupancy," says Blackstone, p. 356 (p. 316 Am. Rep.), "is the taking possession of those things which before belonged to nobody."

This is the true ground and foundation of all property, or of holding those things in severalty, which by the law of nature, unqualified by that of society, were common to all mankind. When it was once agreed that everything capable of ownership should have an owner, natural reason suggested that he who could first declare his intention of appropriating the thing to his own use, and actually took it into possession, should thereby gain the absolute property of it." Upon the ground of occupancy depends one's right to what is called his literary property. Literary property is the right one has to the possession, use, and disposal of his own intellectual productions. A person is pre-eminently the first possessor or occupant of his own ideas, thoughts, and sentiments. The possessor of these mental products may either keep them to himself or by speech freely give them to the public, or put them into the form of property by committing them to

manuscript or print. When these thoughts take the form of property the law treats them as it does all other property. The owner has the right to claim protection against the improper use or appropriation by others of his property; he may give it away or abandon it to the general public; he may derive an income from it, may sell it, or dispose of it by will. Although it is necessary, in order to receive the protection of the law, that literary property be put into some form, the author's property does not consist in the form or the substance upon which his mental productions are inscribed, but in the thoughts, sentiments, and ideas themselves.

The author's rights in and to his property depend upon what is called the common law and certain statutory enactments. His right to his own exclusive control and disposal of his manuscript has never been doubted, but whether he had a common law copyright, that is, a right to multiply and distribute for his own sole benefit copies of his work, or whether by such multiplication and distribution the author did not lose his exclusive right by abandonment to the public, have been debated questions. These differences of opinion have been further emphasized by the consideration of the effect of copyright statutes. The various opinions upon this subject seem to group themselves into three views: First, that at common law an author had the right of multiplying copies for his own benefit; secondly, that he had not such right until it was given to him by statute; and, thirdly, that, although he had a copyright at common law, the statute took it away from him and gave him instead a statutory copyright, which thereafter was the only one he possessed. In the history of judicial discussions upon the subject of the author's right of property all of these views at times have come to the surface. In some of the earlier cases injunctions against the piracy of books were granted upon the ground of the author's common law copyright. In 1710, in the reign of Anne, the first copyright statute was passed. The first view of this statute seems to have been that it did not take away the common law copyright, but was intended to afford additional remedies against piracy. In 1769 the question of the piracy of *Thomson's Seasons* came before the court. In this case (*Millar vs. Taylor*, 4 Burr. 2303) the statutory copyright had expired, and a majority of the court held that literary property did exist at common law and was not taken away by the statute. The same question again presented itself for decision in 1774, in the case of *Donaldson vs. Becket* (4 Burr. 2408), which was carried upon appeal to the House of Lords, where the final judgment, which has been the law from that day to this, was that the statute of Anne had taken away the author's common law copyright, and the only rights of publication he had thereafter were such as the statute secured to him. And this decision was followed by the Supreme Court of the United States, when the same question presented itself, in the case of *Wheaton vs. Peters* (8 Pet. 591), under our own statute of copyright.

Copyright statutes are intended to protect the author's rights in the multiplication and distribution of copies of his work. In most other respects his rights are governed by the usual common law rules applicable to personal property. The great value of literary property, as a source of gain, consists in its owner's ability to make and circulate copies without interference or competition from others. The author's control of his manuscript is exclusive and absolute, but by dedicating his property to the use of the public he loses this sole possession. Publication of a work intended to be protected by the copyright statute, without compliance with the requirements of that act, is a dedication to the public. Literary property may be dedicated to the public by any act of its owner which shows that he abandons his exclusive right of property. Such dedication, however, must be the free, voluntary act of the owner, and not of some one else without his

consent or knowledge. The mere gift of a manuscript confers no right to publish. A restricted circulation of copies, as among friends, indicates no abandonment of the owner's right of property; nor does the use of a manuscript for a particular purpose, as lectures read to a class, give any right to a student or hearer to print and sell for profit, or in any way interfere with the lecturer's rights. (*Abernethy vs. Hutchinson*, 1 H. & T. 39; *Morrison vs. Mount*, 1 Edw. ch. 25; *Miller's Appeal*, 15, W. N. C. (Pa.) 27).

While intellectual productions must assume some form in order to be recognized, identified, and protected as property, no particular form is prescribed, and whether the property exists in manuscript or print the owner's rights are equally protected if he has done nothing to prejudice them. The writer of a letter does not lose his right of property in it by sending it to his correspondent. The sending of the letter is a gift to the receiver of it of the material upon and by which it is written, and the writer loses control over his manuscript to the extent that he cannot demand its return; but no rights of publication are conferred upon the one to whom it is sent, and the writer could restrain such publication, and his right to do this is upon the ground that he has not parted with his property. There may be cases where, perhaps, for his own vindication, the receiver of a letter which reflected upon him might have the right to publish, but some necessity of the kind must exist to justify such a course.

A very common form in which literary property appears is the daily newspaper. These are rarely, if ever, copyrighted. They certainly come within the language of the act and could be copyrighted if desired. But as the great object of such a paper is the first circulation of news, not much would be gained by simply providing against the piracy of its contents. Of course, the publication of valuable material, as letters, or a novel, may be protected by copyrighting such matter for a newspaper or any serial publication. A copyright by the editor of any matter published in his paper would not give him the right to publish it in any other form. The title of a newspaper is valuable property, and the proprietor can be protected against the unlawful use of it by others, but he cannot secure this protection by copyright, as a title cannot be copyrighted by itself, but only as part of a work.

A dramatist's rights in his property differ somewhat from those that pertain to any other kind of literary property. He may have his copyright in it as a literary production, and also his playright or the right of representation upon the stage. And as the value of a book, as a source of profit, consists in the right to multiply and sell copies, the value of a play consists largely in the right to perform it and prevent others from doing so. It is a recognized rule of law that where any kind of literary property is not included within the terms of a statute of copyright the owner's rights are to be determined by the ordinary rules of the common law applicable to such property. The U. S. copyright statutes refer to plays in two respects only. They provide that when an author obtains a copyright for a dramatic composition he only is entitled to represent, or cause to be represented, such play, and, further, that for the unauthorized publishing of any one's manuscript damages may be recovered. If, therefore, a play is printed, the only right of performance is the one conferred by the statute, and, according to the rule which has been followed in the case of copyrighted books, the statute has taken away the author's common law rights. But as the statute nowhere refers to manuscript plays, it would seem that the author's common law rights in them still exist to their fullest extent. And as the author of a book had at common law the exclusive right to multiply copies—for the decisions say only that that right was taken away by the statute—the dramatist had and still has the exclusive right to the performance of his drama. The question whether the public performance of a

manuscript play by its author or owner is a dedication of it to the public, so that thereafter any one could lawfully reproduce it, has not been squarely decided, but the tendency of the decisions seems to be in the direction of holding that such performance is not a dedication and the unauthorized reproduction of the play is a piracy. It has been decided that the performance of a play by its owner does not prevent him from afterward having it copyrighted; and that the performance of a drama which has been obtained from its owner by fraud, breach of trust, or unfair means, will be prevented. (*Keene vs. Wheatley*, 9 Am. Law Reg. 33; *Boucicault vs. Wood*, 2 Biss. 34.) Some courts have decided, and others have to some extent approved this view, that reproducing a play from memory by one who has seen its performance is not obtaining the play by unfair means. This view has, however, been repudiated by courts of equal authority, and certainly seems to be entirely inconsistent with common sense.

Literary property must possess the qualities of innocence and originality in order that its possessor may demand the protection of the law. The law does not generally prohibit the publication of works which are not innocent, but it refuses protection to the owner of such works when others have infringed his rights. It is impossible, perhaps, to give an accurate definition of "innocence" within the meaning of the law. The judicial conception of this quality has varied considerably, and protection was formerly denied in many cases where now it would be granted without question. In England, some years ago, an injunction to restrain the pirating of certain lectures on the "Physiology, Zoology, and Natural History of Man," was refused upon the ground that they contained passages hostile to natural and revealed religion and the doctrine of the immortality of the soul. (*Lawrence vs. Smith*, 7 Jacob. 471.) And the owner of an edition of Byron's *Cain* was refused protection, as, in the opinion of the court, that production was intended to bring into discredit portions of the Scriptures. (*Murray vs. Bentlow*, Shortl. L. Lit. 8.) In this day, however, of free discussion and expression of sentiment it may be safely said that no work which discusses, criticises, or teaches any branch of knowledge, faith, or practice, or which expresses sentiments at variance with those generally held on any subject, would be condemned as not innocent. But works which are openly blasphemous, indecent, immoral, or libellous, or put forth false pretences to authorship which are calculated to deceive the public, still fall under the ban. The certificate of copyright has no effect upon the question of the innocence of the work.

Originality is, perhaps, as incapable of exact definition as "innocence," but there is a legal conception of originality, and this is what the law requires a literary work to possess. The law does not merely refuse protection to a work which does not possess its own originality, but it may restrain the reproduction of the identity of a former work. Every original work possesses an identity; this consists, says Blackstone, "in the sentiments and the language. The same conceptions clothed in the same words must necessarily be the same composition; and whatever method may be taken of exhibiting that composition, to the ear or the eye of another, by reciting, by writing, or printing, in any number of copies, or at any period of time, it is always the identical work of the author which is so exhibited." Any work which appropriates this identity of a former work, in whole or in part, is not an original composition. This originality, however, does not mean absolute newness, for there is no such thing; nor does it exclude all imitation. It does not mean the addition of something new, as a part, to something old, as a part. No number of chapters added to one or more chapters of a work formerly published would make the second publication an entirely new work. The newness must consist in some essential feature of the work. There must be original labor in the plan, selection, arrangement, or

composition. Every word of a work may be found in a subsequent one and yet the last production be entirely original; as a Concordance of Shakespeare. An abridgment, compilation, translation, etc., if the results of original labor, fulfil the requirements of the law. An author does not forfeit his claim to an original production by employing some one to assist or prepare certain portions of his work.

Literary property is as much the subject of contract, under the statutory requirements and limitations, as any other species. The owner of a manuscript may sell it outright, or part with an interest in it. He may retain the property and license its publication for a term of years, or within a certain territory. The license to publish for a certain time would probably carry with it the right to sell copies of the work unsold at the termination of the period. The only satisfaction the law affords for the breach of a contract to write a work is an action for damages. It would be impossible for a court of equity to order a specific performance of such a contract, as a court could not determine, after performance in obedience to its order, whether the original contract had been actually carried out. Where the breach consists not only in a refusal to carry out the contract but in an attempt to perform the same work for some one else than the person with whom the original contract was made, a court of equity can restrain such attempt. No contract to write a work which the law regards as not innocent, as to violate the copyright of another, can be enforced.

Where an author who is producing a literary work under contract with a publisher dies during the progress of the work, as his contract is one of personal skill it dies with him, and his executors cannot be compelled to finish the work or pay damages for its non-completion. The general rule of law is that all one's property is liable to seizure to pay its owner's debts. This, however, is true to a limited extent only in the case of literary property. The products of literary property, the books published, may be taken in execution. And while a manuscript, or the stereotype plates of a book, as a piece of property, may be seized under a levy, such seizure confers upon the officer, or upon one who purchases at his sale, no right to publish for the benefit of the author's creditors or of any one else, because all that is sold is the manuscript or the metal of the plates, and the literary property—the intangible thing of which the manuscript is the form—is not taken. It might be possible, however, under some circumstances, for equity to come to the assistance of creditors, by compelling the taking out of a copyright and the publication of copies.

The injury to literary property which the law is most frequently called upon to redress is piracy—which is the illegal use of another's literary property. As property of this kind is generally protected by copyright, piracy is sometimes defined as the infringement of another's copyright. The literary property must be appropriated or used to render one guilty of piracy; merely stealing a manuscript is not this offence. Where, for any reason, the law does not recognize the right of property, the appropriation of it is not piracy.

The mere taking of another's literary property constitutes this offence, without regard to the intention with which the act was done, and, therefore, ignorance that the property belonged to another, or the absence of any intention to injure, is no defence. Of course, a flagrant intention to injure might be ground for giving greater damages. There may be no pecuniary damage done and the offence would be complete—as in the case of the publication of a work which had been printed for private circulation only and not for profit. Nor is it necessary that the piracy be committed for profit; it may be done for convenience merely. As some one's property must be injured to constitute piracy, the offence is not committed by resorting to the same sources of information, provided such sources are common and open to all alike. There is a fair use of

literary works, already published, which the law recognizes and allows. What is such fair use must be determined by the circumstances of each particular case. It is perfectly fair to use portions of a work for criticism or review, but criticism must not be made a guise for the publication of another's work. And in the same way fair quotation is allowable. The remedies for piracy are an action for damages or an injunction to restrain the act.

Copyright Statutes.—Prior to the adoption of the Constitution of the United States many of the States had passed copyright statutes, but as these were inadequate for the protection of authors outside the boundaries of each State, a provision was inserted in the Constitution giving Congress the power to enact such statutes. The first act of this kind was passed in 1790, and after several amendatory acts were passed from time to time, finally the act of 1870 came into force which repealed all previous laws, and, with a few alterations, constitutes the copyright law of to-day.

The provisions of this act are briefly as follows: Any citizen in the United States or resident therein, who shall be an author of any book, or dramatic or musical composition, and his executors, administrators, or assigns, by complying with the provisions of the law, have the sole liberty of printing, reprinting, publishing, and vending the same; and in the case of a dramatic composition, of publicly performing or representing it, or causing it to be so done. And authors may reserve the right of dramatizing or translating their own works. Copyright is also given in maps, charts, cuts, prints, photographs, paintings, drawings, chromos, statuary, models, and designs.

The copyright is granted for twenty-eight years from the time of recording the title. The author, if living and a citizen of the United States or resident therein, or his widow or children, if he be dead, may have the same exclusive right continued for fourteen years more by complying with the provisions as to recording and advertising within six months before the expiration of the first term. A copyright can be assigned by an instrument in writing duly recorded.

To obtain a copyright there must be deposited with the librarian of Congress the printed title of the book, etc., and two copies of the book. A fine is imposed for failure to deliver these copies.

No action for the infringement of a copyright of a book can be maintained unless there is inserted in the several copies of each edition published, on the title-page or the immediately following page of a book, or on some visible portion of a dramatic or musical composition, maps, etc., the following statement, "Entered according to the act of Congress in the year— by A. B., in the office of the librarian of Congress at Washington," or "Copyright," together with the year the copyright was entered, and the name of the person by whom it was taken out.

Any one who knowingly prints, publishes, or sells a book or other work, or performs a drama, duly copyrighted, without the written consent of the owner, duly attested, forfeits every copy of the book or the work issued in violation of the copyright, and in his possession; and is also liable to damages.

Damages may be recovered for printing or publishing any manuscript without the consent of the author, if he is a citizen of the United States or resident therein.

The act further provides that an injunction may issue to protect a copyright; and that the provisions of this law do not extend protection to aliens and non-residents.

The words of this act have frequently received judicial interpretation. The applicant, if not a citizen, must be a permanent "resident." The assignee of a foreign resident is not entitled to copyright. "Author" includes any one who performs original labor in composition, whether as writer, translator, or abridger. A "book" may consist in a diagram of one page, with directions for cutting ladies' dresses, as well as the bound volume of many pages. All the contents of a book,

including engravings, etc., are covered by a copyright. Any mode of depicting action, whether by words, ballet, or pantomime, is included under the term "dramatic composition," and the copyright of such a production will protect the music in the action, the letterpress, the text, and the dramatic incident or situation, but not the mechanical arrangement for facilitating the flow of the incident.

There is no international copyright statute in the United States, though vigorous efforts have been made for some years by native authors as well as foreigners to induce Congress to pass such a measure. (S. C. P.)

PROPHETS. In this article we will consider first the phraseology employed in the Old Testament to describe prophecy and the prophets; secondly, the history of the succession of men known as the prophets; thirdly, their position and functions; and, fourthly, the written works commonly described as the books of the prophets.

I. The word commonly translated "prophet" is *nābhî*, נָבִי. Other words of the same stem are translated "prophesy," "prophecy," "prophetess." The derivation of the word is unknown, and is of no consequence; even the assertion that it is borrowed from the Canaanites is a mere guess. Practically, the word is a technical term used to describe a certain class of men and their acts; the only way to define it is to learn what we can concerning the men.

The phrase, "man of God," has precisely the same meaning as the word "prophet," so far as the person denoted by it is concerned; it is never applied to a priest as such, or to a holy man as such, but always to one who is thought of as having the prophetic character.

The word *roeh*, רֹאֵה, translated "seer," is used a few times to denote the person who is more commonly called a prophet, or a man of God. It is from the stem which primarily denotes ordinary eyesight. Two different nouns of this stem are sometimes translated "vision." The passive verb of it may be translated "appear," and is the verb regularly used to describe the instances when Jehovah is said to have appeared to his servants. The active and the causative verbs of this stem are frequently used of the seeing of visions. In the use of these words a prophet is described as a man to whom Jehovah reveals truth by causing it to take a form in which it is thought of as visible to the eye. Ezekiel's visions of the winged creatures are familiar instances.

A prophet is also sometimes called *hozeh*, הוֹזֵה, also translated "seer." Several words of this stem are translated "vision," and the verb may be used in the cognate sense. In some of the other Shemitic languages this stem is employed to denote ordinary eyesight, but in Hebrew it is restricted to the idea of insight or of thoughtful seeing. Used of the visions of a prophet, it may include other forms of divine revelation than those that are thought of as presented to the eye. The word "vision," as found in the titles of the prophetic books, is always a word from this stem (Isa. i. 1, *e. g.*). Where words of the two stems are found in the same context the derivatives of *roeh* should be regarded as generic, and those of *roeh* as specific.

The prophetic gift is currently said to be by "the Spirit of Jehovah" (1 Kings xviii. 12; Isa. lxiii. 10, 11; Joel ii. 28, 29 (iii. 1, 2); 2 Chron. xv. 1, etc.).

The phrase "the word of Jehovah," very rarely "the word of God," is used throughout the Old Testament to describe the message brought by a man endowed with the gift of prophecy, *e. g.*, Mic. i. 1; Jonah i. 1; Jer. i. 4. The word *massa*, מַסָּא, "burden," is used from Elisha's time onward to denote a prophecy of a certain character (2 Kings ix. 25; Isa. xiii. 1, etc.).

In Hag. i. 13, 2 Chron. xxxvi. 15, 16, and possibly elsewhere, a prophet is called a "messenger," or angel,

of Jehovah. Prophets are also called "watchmen," "servants of Jehovah," "shepherds." In Mic. ii. 6, 11, the word translated "prophet," "prophecy," means physically "to let drop," and so "to talk sagely," to be a sage. But all these are figures of speech, or descriptive phrases, rather than strictly proper terms.

Most of the terms descriptive of prophets and prophecy are actually used in three degrees of extension: first, to denote a man whose distinguishing characteristic is the possession of the prophetic gift, such a man, for example, as Samuel or Isaiah; secondly, to denote any man who has the prophetic gift, even though he is more distinguished in some other direction—Moses, for example, or David, or doubtless Ezra or Nehemiah; thirdly, to denote the men who are also called "the sons of the prophets," that is, the secondary prophets, the disciples or followers of the great prophets (1 Kings xx. 35, 38; 2 Kings ix. 1, 4). For the sake of distinction, we may apply the term "prophetic men" to the second of these three classes.

II. The sources of information concerning the prophets are two—the testimony of the Old Testament, slightly supplemented by testimony from other sources, and the analogy between the religious history of Israel and that of other peoples. In its treatment of the testimony, the article in the *ENCYCLOPÆDIA BRITANNICA* assumes that it is necessary first to recast a large part of the text of the Old Testament, and then to reject certain statements as untrue, and to discount others as fictional. We shall get an account somewhat different if we examine the testimony as it stands, without any preliminary manipulation; and if this account turns out to be consistent and credible it is of course to be preferred to the other.

Before Samuel's Time.—The Pentateuch and some of the later books attribute the gift of prophecy to the patriarchs. Abraham is called a prophet (Gen. xx. 7; 1 Chron. xvi. 22; Ps. ev. 15). The "word of Jehovah" came to him (Gen. xv. 1, 4). Several times it is said of him and of Isaac and Jacob that they had divine visions, or that Jehovah "appeared" to them (Gen. xv. 1; xlv. 2; xii. 7; xvii. 1; xviii. 1; xxvi. 2, 24; xxxv. 9).

Prophecy is represented as being very abundant in the times of Moses and Joshua. Moses himself, though we are accustomed to think of him chiefly as a lawgiver, is currently described as "the man of God," and is said to have been the greatest of prophets (Deut. xxxiii. 1; xxxiv. 10; Josh. xiv. 6; Ezra iii. 2; Hos. xii. 13, and very many other places). Miriam is called a prophetess (Ex. xv. 20). Moses is compared with other prophets of his time (Num. xii. 1, 6, 7). We have an account of the prophesying of Eldad and Medad and the seventy in Num. xi. 25-29. The function of a prophet as the special spokesman of his God is assumed to be a well known fact, and is used for the purpose of an illustration (Ex. vii. 1). Specific legislation in regard to prophets is given in Deut. xviii. 15-22; xiii. 1, 3, 5.

But it is alleged that these testimonies come largely from sections of the Pentateuch that are of late date, and that they must therefore be regarded as carrying back into the patriarchal and Mosaic periods the phraseology that properly belongs to later times. In reply to this: First, if all the testimony in the case were of late date, that would not prove the inference as drawn, but would merely open the way for proving it; the statements are still credible unless disproved. Secondly, part of the testimony in the case is from other sources than these alleged late parts of the Pentateuch. Thirdly, irrespective of the phraseology used, the testimony to the facts is clear; it does not depend on the question whether the narrator used the phraseology of his own times or of the times of which he wrote. Fourthly, it is to be noted, however, that in several of the instances cited the writer puts the phraseology describing prophecy into the mouth of Je-

hovah, or of Moses, or some other person, thus apparently representing it to be the phraseology of the time when the events occurred. Finally, the allegation that these sections of the Pentateuch are of late origin is itself not to be accepted without proof, and the proof of it is not forthcoming. (See article *PENTATEUCH*.)

Prophecy is represented to have been in existence in the times of the judges, though the thread of testimony is here slender. It is said that Deborah was a prophetess (Jud. iv. 4); that "a prophet man" came in the Midianite times (vi. 8); that the angel of Jehovah "appeared" to Gideon and to Manoah (vi. 12; xiii. 3, 21); that Manoah and his wife were familiar with the character of a "man of God," and described by that phrase the person who appeared to them (xiii. 6, 8). It is mentioned as marking the time when Samuel was a child that "the word of Jehovah" was then scarce, there being "no open vision" (1 Sam. iii. 1); though even for that time we have an account of a divine message brought by a "man of God" (ii. 27). When Samuel became a distinguished prophet, we are told that Jehovah "again appeared in Shiloh, for Jehovah was revealed unto Samuel in Shiloh in the word of Jehovah" (1 Sam. iii. 21). This seems to imply the restoration of a state of things that had existed in Shiloh before the time of especial scarcity of "the word of God."

The facts thus testified to are entirely consistent with the statement made in 1 Sam. ix. 9. It is there explained, to account for the fact that Saul inquired, not for the prophet, but for the seer, that "seer" was then the term in common use. It does not follow that the term "prophet" had never been known till then; the facts we have been examining rather show that it had been temporarily superseded by the word "seer," this being one of the phenomena of the time of the scarcity of the prophetic gift.

Prophecy in the Times of Samuel, David, and Solomon.—In Acts iii. 24 (cf. 22), in the same breath in which Moses is spoken of as a prophet, we read of "all the prophets from Samuel and them that followed after," as if Samuel was in some sense the first of the prophets. This agrees well with all the statements of the Old Testament. Prophets and prophecy had existed in Israel from the earliest times, but under Samuel they assumed new forms and a fresh importance. Samuel himself, followed by Gad, David, Nathan, Asaph, Heman, Jeduthun, Zadok, Solomon, Ahijah, Shemaiah, Jedo (spelled Iddo in the King James version), form a group of distinguished prophets and prophetic men (see Concordance of Proper Names). Besides these, we find "the companies of prophets," mentioned in 1 Sam. x. and xix., probably organized by Samuel, and certainly controlled by him to a large extent. The attempt to make it appear that Samuel, being a seer, was therefore not properly a prophet, but that the prophets were a different class of men, who afterwards absorbed the class known as "seers," is not a success. The true statement of the difference between such a man as Samuel and the ordinary members of the prophetic companies is, that most of the latter, like the "sons of the prophets" of later times, were mere secondary prophets—the followers and disciples of the men who were recognized as having great prophetic gifts.

Prophecy in the Later Periods.—The next group of prophets is that of which Elijah and Elisha are the great figures. The men of this group who are named in addition to these two are Oded, Azariah, Hanani, Jehu, Micaiah, Jahaziel, Eliezer, the high-priest Jehoiada, and his son Zechariah. But, in addition to these, prophets are represented to have been very numerous, especially in the Northern kingdom. Obadiah, for instance, saved the lives of a hundred of them, at a time when this was apparently only a small proportion of the whole number (1 Kings xviii. 4; cf. xix. 10). The so-called schools of the sons of the

prophets were flourishing at Jericho, Gilgal, Bethel, and doubtless other places. Very likely most of the numerous prophets were so only in the sense of being members of these organizations. At this time, also, we find mention made of great numbers of false prophets who prophesy in the name of Jehovah (1 Kings xxii.), whether we regard these as mere pretenders or in some other light. The next group is that of which Isaiah is the chief figure, including Jonah, probably Joel and Obadiah, Amos, Hosea, the Zechariah named in 2 Chron. xxvi. 5, Isaiah, the Oded named in 2 Chron. xxviii. 9, Micah, Nahum. Throughout this period true prophets are spoken of as numerous, and false prophets as equally so. (To find instances use Concordance.) The next group includes the Palestinian prophets of the time of Jeremiah. Besides him, we have some account of Habakkuk, Zephaniah, Uriah (Jer. xxvi. 20-23), and Huldah (2 Chron. xxxiv. 22). Prophets, both true and false, are still numerous. Of false prophets, Ahab, Hananiah, and Shemaiah are mentioned by name, with some details (Jer. xxix. 21; xxviii. 10; xxix. 8, 24). Still another group is that of the prophets of the exile in Babylonia. Of these Daniel and Ezekiel are the prominent ones. False prophets are numerous, both male and female, and possibly true prophets also. A final group is that of the post-exilic prophets. To this group belong Haggai, Zechariah, and Malachi, and, by fair implication, Ezra and Nehemiah are to be regarded as prophetic men. The existence of other prophets is referred to, with false prophets among them (Zech. vii. 3; viii. 9; Neh. vi. 7, 14). The Jewish traditions concerning the men of the Great Synagogue affirm that many of these men were prophets. With the death of Malachi the succession of prophets is held by Jewish tradition to have ceased (1 Mac. ix. 27; iv. 46; xiv. 41; Josephus *Cont. Ap.* i. 8).

III. The character and functions of a prophet are briefly outlined in such passages as Ex. vii. 1; Num. xii. 6; 1 Sam. iii. 20, 21; Deut. xviii. He is simply a citizen ("of thy brethren, like unto me") who speaks for Jehovah in a special message given him for the purpose. He differs from the practitioners of magic arts in that he has genuine communications with the invisible world, through the word of Jehovah, revealed to him. He differs from the Levitical priest, in that his message is special, and not a matter of regular routine. The simplicity of the Old Testament statements concerning the prophets is quite remarkable. The prophets did and saw wonderful things, but so far as they themselves are concerned, the elements of mystery and marvel are conspicuously absent, except as these have been interpreted into the Old Testament accounts from other sources.

The Personal Appearance of the Prophets.—Our most current picture of a prophet is one for which some ecclesiastic or monk sat as a model, the artist modifying the picture, according to his fancy, by elements copied from the Greek oracle priests, or from Eastern dervishes. But we may as well start by reminding ourselves that in part the picture is contrary to the facts, and in part the facts are unknown. It is customary to infer from Zech. xiii. 4, Isa. xx. 2, 3, 1 Sam. xxviii. 14, 1 Kings xix. 13, that the prophets as a class wore a peculiar garb to distinguish them from other people; but the passages do not justify the inference, and the contrary is fairly to be inferred from 1 Sam. ix. 18, 2 Kings i. 7, 8, etc. On the strength of 1 Sam. xviii. 10, xix. 19-24, Jer. xxix. 26, and like passages, it is frequently alleged that frenzied utterance was characteristic of the prophets, and indeed that this is the radical idea of the word "prophet" itself. But the assertion that Jeremiah raved is mentioned as a slander, and not as a fact. Saul acted like a crazy man when the spirit of prophecy came upon him at Ramah, but he acted so because he was crazy at the time; the passage does not say nor necessarily imply that any one but Saul acted so. In 1 Sam. xviii.

10, Saul's raving is called "prophesying;" but this may be not because prophesying is thought of as a species of raving, but because Saul, when he raved, talked religiously, like a prophet. Ordinarily, the words and deeds of the prophets, even those that are strangest, or most impassioned, are marked by very clear, self-contained common sense. It is safest to think of a prophet as having the dress, the appearance, and the habits of an ordinary citizen, except in the instances where particular prophets, for particular purposes, are described as dressing or acting otherwise.

The Prophetic Schools.—The term "school," as thus applied, is not Biblical, but is convenient. The evidence does not show to what extent the organizations of Samuel's time (1 Sam. x.-xix.) resembled those of the times of Elijah and Elisha (see especially 1 Kings xx. 35-41; 2 Kings ii. -ix.), but it is a natural conjecture that they were much alike. From 2 Kings v. 22, ix. 1, 4, it is natural to infer that the members of these organizations were mostly young men. That married men were included among them appears from 2 Kings iv. 1. That they were of the obscure class in society has been inferred from 1 Sam. x. 11, but the inference will hardly hold; the surprise that Saul should be among the prophets shows, indeed, that his reputation was different from that of the others, but not necessarily that he was more prominent than they; it may just as well be that he was known as less religious than they. From what is said in the chapters referred to, it appears that the sons of the prophets sometimes lived together in common residences, that contributions for their support were sometimes made by citizens, that they were accustomed to organized action for their own comfort, and for other purposes, that they took their part in national politics, that they cultivated music, that they sometimes held out-of-door religious services (1 Sam. x.), that they had certain exercises in concerted prophesying of some sort (1 Sam. xix.). Whether these were schools or not, they were not mere schools, but organizations for public work and influence. Whether they had anything like a course of study and training we are not informed. As we have seen, their members were sometimes called prophets, but it by no means follows that most or all of them regularly became endowed with prophetic gifts. That some of them became so endowed is probable; and it is also probable that the name "prophet" would come to be applied to them, in general, whether they had the gift or not.

The So-called Prophetic Order.—It is probable that the prophets were an unbroken succession, in the sense that from Malachi back to Samuel, and earlier, Israel was never wholly without living prophets of Jehovah. But in addition to this a great deal is said about the prophetic order, as if the prophetic body had an organic character, like that of the priests, or was perpetuated by some ordaining act, like the ministry in the Christian churches. It is true that some priests were prophets or prophetic men, Zadok, Jeremiah, and Ezra, for example; it is also true that a prophet, not of the priesthood, might be commissioned to perform priestly acts, Moses for example, Lev. viii. 15-30; but there is no trace of any priestly functions regularly exercised by the prophets, as prophets, nor of any properly prophetic functions regularly exercised by the priests as such. In this the religion of Israel differed notably from certain other ancient religions. The only alleged instance of anything like ordination is the setting apart of Elisha, 1 Kings xix. 15, 16, 19; cf. 2 Kings ix. 1-13. But Elisha's case is evidently exceptional, like the parallel cases of Jehu and Hazael. He was not set apart to be a prophet, but to do certain especial work as a prophet.

In fine, a prophet became such, so far as appears, solely by becoming endowed with prophetic gifts; he came to be recognized as a prophet by its being perceived that he had the gifts (Deut. xviii. 21, 22; xiii. 1-5), and not ordinarily through his costume or per-

sonal appearance, or mode of life, or registry of ordination. But men might, of course, become secondary prophets by merely becoming followers of the prophets whose gifts were recognized.

Certain Naturalistic Functions of the Prophets.—They were prominent as the public men of their times. In proof, note what is said concerning the career of Moses or Samuel, Elijah, Elisha, Isaiah, Jeremiah. They were the leaders of the party that advocated a certain religious policy on the part of the government, and of the party that opposed foreign alliances in every direction. After the Babylonian conquest became an accomplished fact, such prophets as Jeremiah advocated the political action that accepted it as a fact. As long as the separate kingdoms of Israel and Judah existed, the prophets were a bond of unity between the two kingdoms; Judean prophets like Amos and Isaiah prophesied for the Northern kingdom, and northern prophets, Elisha and Hosea, for instance, for the Southern kingdom (Am. i. 1; iii. 1, 12, etc.; Hos. xi. 12, etc.; 2 Kings iii. 14; Jer. xxx. 3, 4; xxxi. 1, 5, 6, 9, 12, 15, 18, 20, 27). In short, a biography of the prophets would be a history of Israel.

They were the reformers of their times. Besides religious questions, they discussed improper divorce, licentiousness, usury, land monopoly, drunkenness and dissipation, slavery, and like questions (Mal. ii. 10-16; Jer. v. 7-9, etc.; Neh. chap. v.; Ezek. xviii. 8, etc.; Isa. v. 7-10, 11-22; Jer. xxxiv. 8-22, and the prophetic books throughout). Further, they were evangelistic preachers and organizers. As a rule, the prophetic books are homiletic. Still further, they were the literary men of the nation. This is of course true of the so-called literary prophets and their contemporaries, and among those who lived earlier the Bible attributes authorship to Elijah, Jehu, Shemaiah, Jedo, Ahijah, Solomon, David, Ethan, Heman, Asaph, Nathan, Gad, Samuel, Joshua, Moses. So far as functions of these kinds are concerned, the prophets of Israel have their counterparts among two classes of men, in all ages: first, among devout religious workers, adherents of the true religion; and, secondly, among the especially gifted men whom God anywhere raises up for special purposes in the history of mankind.

Wonder-Working by the Prophets.—But in addition to all such functions as have been mentioned, the Old Testament attributes distinctly supernatural powers to the prophets. Under the influence of the Spirit of Jehovah, supplied to them for that purpose, they became workers of miracles. Familiar instances of this sort are to be found in the accounts given of Elijah and Elisha. Very prominent among their miracles is the supernatural discovering and revealing of secrets, *e. g.*, 2 Kings vi. 12, or Dan. chap. ii.

The Prophets as Predictors of Events.—In Christian apologetics, the argument from fulfilled prediction has constituted one of the chief uses made of the prophecies. Owing in part to this fact, many persons unquestionably make the predictive element too prominent in their ideas of prophecy. Prediction is far from being, as many imagine, the central and essential factor in prophecy. Nevertheless, the Old Testament represents it as a real factor, and an especially important one. Evidently a prediction might be one of the signs whose fulfillment would accredit the prophet who speaks in Jehovah's name, Deut. xviii. 22; xiii. 1-5. Fulfilled predictions are prominently claimed as having this effect, *e. g.*, Isa. xli. 22, 23, 26; xlii. 9; xliii. 9, 12, 18, 19; Zech. i. 4-6.

Messianic Preaching by the Prophets.—That which the prophets make most prominent in their utterances is the doctrine that Israel is Jehovah's peculiar people, in virtue of Jehovah's purpose, and his covenant with Abraham, Isaac, and Jacob; that this covenant promise and purpose has been receiving fulfillment up to the time when each prophet lived, and is to have yet larger fulfillment in the future. In all the pro-

phetic writings this doctrine, either expressed or implied, lies at the basis of all counsel, all rebuke, all exhortation to repentance or obedience, all encouragement, all comfort, all direction for private life, all patriotic appeal, all religious teaching. The doctrine is central in the discourses of the prophets, just as the doctrine of a crucified and risen Christ is central in the discourses of the apostles. A part of this doctrine is that Israel's mission as Jehovah's peculiar people is not for himself alone, but for all the nations. The passages cited in the New Testament in support of the claims of Jesus are, with hardly an exception, those in which the prophets teach this great central doctrine. The New Testament claim is essentially that the promised fulfillment of Jehovah's covenant purpose with Israel mainly comes about through Israel's Christ, and that Jesus of Nazareth is that Christ.

If this view be correct, we have in the Old Testament not a great number of predictions concerning the Messiah, but a single prediction, often repeated in a great variety of forms and aspects. If we make a distinction between prediction and promise or doctrine, the Messianic utterances of the Old Testament are of the nature of promise and doctrine rather than of prediction, though this does not render them any the less genuinely predictive. With this view of the matter, we need neither affirm that the evangelists claim that the prophets had in mind the person of Jesus, when they wrote these passages, nor admit that the evangelists used the passages in an accommodated sense. From the point of view of the great covenant promise, they regard the history of the Christ as the crowning portion of the history of Israel, and they interpret accordingly what the prophets say of the future history of Israel, as fulfilling the covenant promise.

The Prophets and Jehovah's Law.—The handling of the *Torah* of Jehovah is, in the Old Testament, attributed to both the priests and the prophets. It does not follow that there were two different bodies of Jehovah's law—a prophetic *Torah* and a priestly *Torah*. The difference seems rather to be that the priests, in association with the magistrates, were the custodians, teachers, and interpreters of such law as Jehovah had already given (Deut. xxxi. 9; xvii. 8-12, 18, 19; 2 Chron. xv. 3; xvii. 9; Jer. ii. 8; Lev. x. 11; Deut. xxxiii. 10; xxiv. 8; Mic. iii. 11; 2 Kings xvii. 27, 28, etc.), while the prophets not merely give instruction in the law, but bring the law from Jehovah (Isa. viii. 16, 20; Neh. ix. 26; Jer. xxvi. 4, 5; Dan. ix. 10; 1 Sam. xii. 23, etc.). The representation everywhere seems to be that through the prophets Jehovah revealed the *Torah*, which it was the duty of the priests merely to administer.

The term "*Torah*," as thus used, seems to have been applicable to any particular revelation made by Jehovah to a prophet, especially if the revelation were committed to writing, and again, to have been applicable collectively to the whole body of such revelation. It is more correct to say that it is often so used as to include the sacred writings attributed to Moses, than to say that it is currently used to denote those writings. Long before the Christian era, however, those writings had come to be regarded as the *Torah par excellence*.

Modes of Divine Revelation to the Prophets.—As we have already seen, the inspiration of the prophets is represented to have been by the Spirit of Jehovah. The modes in which the Spirit is said to have communicated with them are commonly classified as three, namely, by dreams, by visions, and by direct revelation. A better classification is that suggested by the terms employed to describe the prophets, namely, first, by dreams (Num. xii. 6; Deut. xiii. 1; Dan. i. 17), with the dreams of Joseph, Solomon, etc., and the interpretations by Joseph, Daniel, etc.; second, by sense-visions, the presenting of object lessons, thought of as visible to the eye, as in Zech. i. 8-13, 18-21; ii. 1-5; iii., etc.; third, by theophanies, Jeho-

vah (usually in the character of "the angel of Jehovah") taking visible form and appearing to the eye, or attracting the eye by some visible manifestation (the burning bush, for example), and then communicating directly with the person thus aroused; fourth, by excited insight, or other form of mental vision, as distinguished from sense-vision. Among the most familiar instances of theophany are those described in Gen. xviii., Ex. iii., the events at Sinai, Jud. xiii. Perhaps the instance in 2 Kings iii. 15 is an instance of mental vision as distinguished from sense-vision. It may be presumed that most of the instances described by words of the stem יָרָא are instances of mental vision, except as otherwise specified. Theophany, in either form, is regarded as the highest form of divine communication.

Modes of Utterance by the Prophets.—Certain peculiar modes of utterance by the prophets bear a close analogy to the modes of revelation just considered. For example, they use symbols, that is, physical objects or personal acts representing the truths they have to utter, e. g., 1 Kings xi. 30, 31; Ezek. xxxvii. 15, seq.; Isa. chap. xx. A higher class of symbols are those called types. The subject of prophetic typology has been voluminously discussed, with much difference in definition and opinion. Perhaps the best definition of what is properly to be called a "type" is that it is an object or event used to present a great truth in such a way that it becomes a foreshadowing example of a greater presentation of the same truth. Thus Christian theology might hold that the Levitical sacrifices were types of the sacrifice of Christ, or that each member of the line of great Old Testament prophets was a type of Christ in his prophetic office.

No utterances of Jehovah's prophets have a double meaning in the sense of being equivocal in meaning. In some cases which have been regarded as presenting a double sense, the New Testament uses a prophetic passage simply for illustration. An instance of this kind, doubtless, is that in which Matthew applies Jeremiah's language concerning Rachel weeping for her children to the case of the innocents slaughtered by Herod, Matt. ii. 18; Jer. xxxi. 15. But there is a large class of instances in which a prophecy may have a manifold application, or a manifold fulfilment, without being equivocal in meaning. Types and anti-types, for example, may occur in a series, so that the foretelling of one event amounts to the foretelling of all the future events in the series. Or a statement made concerning some part of a complex event may equally be true of the whole, or *vice versa*. Or a prediction may be capable of a successive or a progressive fulfilment. Or the foretelling of a final event in a historic process may imply that of many of the events that lead up to the final event. It is evident that in these and other ways a prophecy may be generic without being ambiguous. And still further, when a prophecy, whether properly predictive or not, enunciates a principle on which God acts, its statement may be made to apply to every case in history that comes under the principle.

IV. The Jewish tradition counts the Books of Joshua, Judges, Samuel, and Kings as the four books of the earlier prophets, and the Books of Isaiah, Jeremiah, Ezekiel, and the twelve Minor Prophets as the four books of the later prophets. By one form of the tradition—a form which is corroborated by the arrangement of the versions and by the phenomena in the case—Ruth is counted as a part of the collection of the earlier prophets, being regarded as one with Judges, but our present Hebrew Bibles put Ruth in the Hagiographa. They also put Lamentations in the Hagiographa, though another form of the tradition counts this book along with Jeremiah as prophetic. Starting from the idea that prophecy is mainly prediction, it is sometimes mentioned as remarkable that Daniel, the book more marked by prediction than any other, is uniformly reckoned among the Hagiographa,

and not in the division called the Prophets; but really, the fact that the book is predictive, to the exclusion of the homiletical element, constitutes a sharp difference between it and most of the books that are classed as prophetic. Whatever may have been the reason for classifying this list of books as "The Prophets," it certainly does not indicate that the men who made the classification regarded the Pentateuch and the Hagiographa as of non-prophetic authorship. It is beyond dispute that they, whoever they were, regarded Moses, David, Daniel, and others as prophets, and regarded all the Old Testament as written before the disappearance of prophecy. See articles on BIBLE and CANON.

The records contained in the Books of Judges, Samuel, and Kings, up to the times of Jeroboam II. of Israel, doubtless consist largely of transcriptions from writings of Samuel, Gad, Nathan, Ahijah, Shemaiah, Jehu, and other prophets, who flourished before the times of Amos and the other earliest prophets whose names are attached to our present prophetic books. This fact, or even the traditional opinion that this was the fact, affords a natural and plausible reason why these books should be called the books of the earlier prophets. See further in the articles JUDGES, RUTH, SAMUEL, KINGS.

The books commonly called the twelve Minor Prophets seem to be arranged in what their collector regarded as four chronological groups. The last three, *Malachi, Zechariah, and Haggai*, belong to the Persian period. The two next preceding, *Zephaniah and Habakkuk*, belong with *Ezekiel and Jeremiah*, in the Babylonian period. The next two preceding, *Nahum and Micah*, belong with most of Isaiah in the later Assyrian period—the period of the Sargonidæ. The intention seems to have been to indicate that the first five of the twelve books belong in a group together, dated by the dates of *Hosea* and *Amos* as in the middle Assyrian period—the period to which Tiglath-pileser gives character. *Hosea* is placed first, though it is not the earliest. The Jewish traditions explain this by the fact that it is the largest of the twelve books. The earlier prophecies of Isaiah belong with these five books to the middle Assyrian period, and the historical situation of *Zech. ix.-xiv.* is that of the same period, no matter when these chapters were written. Our study of the books will be facilitated if we first make a brief survey of the history of the period.

On their face the Biblical numerals give 175 years for the interval between the accession of Jehu and the destruction of Samaria. The chronology most commonly received so treats the numerals as to reduce this by a few years, and the chronology now accepted by many Assyriologists and others rejects a part of the statements of the Bible, and reduces the length of the period by about fifty years. It is not a matter of indifference which chronological theory we accept, but we need not now discuss the question, as the point before us does not depend upon it. In any case the first decades of the interval belong to what may fairly be called the earlier Assyrian period, that in which Shalmaneser II. figures prominently. This monarch mentions Samaria and nearly all the Palestinian countries except Judah as his tributaries, and says that Hazael of Damascus, who came to the throne at about the same time with Jehu, was conquered after some resistance. According to the accounts in the Books of Kings and Chronicles, Hazael's reign lasted some forty-six years, his son Benhadad being a part of the time associated with him in some capacity; it covered the reigns of Jehu and his son Jehoahaz in Israel, and those of Athaliah and Joash in Judah. Hazael was the enemy of Israel. We may assume that he was checked by the power of Assyria, but before the death of Jehu he had "cut Israel short" and gained control of the country east of the Jordan. Later, he and his son Benhadad utterly wasted the Northern kingdom, and finally, in the last year of Joash of

Judah, he invaded Philistia, and afterward marched against Jerusalem. Meanwhile, according to the Moabite stone, corroborated by such notices as that in 2 Kings xiii. 20, the Moabites were also engaged in acts of successful hostility against the two Israelite kingdoms, and we may assume that their usual allies, the Ammonites, were associated with them.

The great event of this part of the history is Hazael's expedition against Jerusalem. The accounts of it are brief, but with several very distinct particulars. It occurred just at the close of the reign of Joash of Judah, 2 Chron. xxiv. 23, 25. The utter wasting of the Northern kingdom had continued up to that time, that is, all the days of Jehoahaz, 2 Kings xiii. 3, 14, 22. Hazael first took Gath, and started for Jerusalem from that direction, 2 Kings xii. 18 (17). With a comparatively small force he signally defeated a very great army of defence, 2 Chron. xxiv. 24. He destroyed the princes of Judah, and captured their spoil, 2 Chron. xxiv. 23. Joash bribed him to leave by giving him sacred treasure from the king's house and the temple, 2 Kings xii. 19 (18). It is not said that he captured Jerusalem. He left Joash of Judah prostrated by illness and about to be slain by conspirators, 2 Chron. xxiv. 25. Very soon after, Hazael died, and Joash, the newly crowned king of the Northern kingdom, was able, notwithstanding the depleted condition of his power (2 Kings xiii. 7), to overcome Benhadad in a succession of battles and recover the cities of Israel.

Rimman-nirari, the contemporary king of Assyria, grandson of Shalmaneser, says that Tyre, Sidon, the land Omri, Edom, Philistia, were tributary to him, and immediately adds an account of his besieging Mariha, king of Damascus, and compelling him to submission and to the payment of immense fines. These operations are not dated, but it is plausible to conjecture that Mariha (the lord) is an appellation for Hazael, and that the interference of the Assyrian king may account for the successes of Joash of Israel. But whether this conjecture be accepted or not, the Biblical account is that the successes of Hazael at Jerusalem were presently followed by his death and the humbling of his kingdom.

It remains further to be noted in connection with these events that Amaziah, the successor of Joash of Judah, a few years later regarded himself as having reason to take bloody vengeance on the Edomites; possibly this may suggest something as to the attitude of Edom in the days of Hazael.

Joash of Israel reigned sixteen years, and was succeeded by Jeroboam II., who reigned forty-one years. In Jeroboam's twenty-seventh year Uzziah became king of Judah. Waiving the question whether we should count the numerals as overlapping one another, and should thus, or by any other process, count the period as shorter than it at first seems to be, our attention should now be fixed on the fifteen years (or whatever the number may be) during which Jeroboam and Uzziah are said to have been contemporary. The situation now contrasts very strongly with that when Hazael made his attempt upon Jerusalem. Jeroboam "restored the border of Israel from the entering of Hamath unto the sea of the Arabah," 2 Kings xiv. 25. He "restored Damascus and Hamath to Judah in Israel," xiv. 28. Of Uzziah it is recorded that he built Elath, 2 Kings xiv. 22; that he made successful war with the Philistines and other enemies, and received tribute from the Ammonites, 2 Chron. xxvi. 6-8; that "his name spread abroad even to the entering in of Egypt," xxvi. 8; that he fortified Jerusalem, and had an immense army, xxvi. 9-15; that "his name spread far abroad," xxvi. 15. It is common to assume that Judah and Israel were at this time in hostility; but the passages cited more naturally imply the contrary, and give us to understand that they were two kingdoms with one policy and purpose, and with a sway under which Hamath, Syria, Damascus, the Ammonite coun-

try, and Philistia were included as tributaries. This, with the possession of the Elanitic gulf, implies the subjection of Moab and Edom, as well as of the peoples mentioned.

We instinctively ask how it was possible that Assyria would allow such a power to spring up in the west, and reduce her tributaries to tribute? At present, there is no answer to this question, but certain Assyrian inscriptions of a few years later testify to the fact that these Assyrian tributaries actually had "in their faithlessness made revolt to Azariah" giving him such strength as to make him a formidable foe to Assyria. See Schrader's *Cuneiform Inscriptions*, translated by Whitehouse (pp. 208-212), or the inscriptions attributed to Tiglath-pileser, in any collection of Assyriological matter. The inscriptions in question are so mutilated that very little can be learned from them, but they clearly agree with the Biblical statements as to the greatness of Uzziah and the extent of the sway of the combined Jewish-Israelite kingdoms of this period. They further indicate a temporary decadence of the Assyrian empire, covering a longer or briefer time, between the date when Assyria held all this region in undisputed subjection, and the date when Assyria was making efforts to wrest the same region from its allegiance to Uzziah.

Leaving the remainder of the history, for the present, we are now ready to look at the prophetic books which connect themselves with the history as already sketched.

The Book of Amos.—This book dates itself "in the days of" Uzziah and Jeroboam, "two years before the earthquake." The best analysis of it makes it to consist of four discourses, the song "I will not reverse it," i. 3-ii. 16, the exhortation, iii.-iv., the lamentation, v.-vi., and the book of visions, vii.-ix. The present treatment will be confined to a single point, namely, the historical situation presented in the book.

This is twofold: the book is quite distinct in its picture of the times when it was written, and in addition to this, it is very distinct in its presentation of a certain earlier period, to which it alludes in the way of reminiscence. We find here the same representation that we found in the historical books as to the extent of the dominion of Israel in the reigns of Jeroboam and Uzziah. "From Hamath to the brook of the Arabah," Am. vi. 14, shows this, as does the challenge to compare the region of Assyrian conquests centring in Calneh with the region from Hamath to Gath, vi. 2. If "Damascus" is the correct reading in iii. 12, that verse represents Israelite grandees as living in luxury in the subject city Damascus. It follows that some at least of the peoples mentioned in i. and ii. are there thought of as dependent on Israel and Judah, and not as independent.

We find the same community of interest between Israel and Judah that we found in the accounts in the historical books. Amos is a Judaite, i. 1. His predilections are for the house of David, ix. 11, *et al.* But his prophecy refers almost exclusively to the Northern kingdom. He seems to know no difference between Jeroboam's Hamath and Uzziah's Gath, but speaks as if both were included in the same interest. The passage between him and Jeroboam's priest Amaziah (vii. 10, 12) could hardly have taken the form it did, except when the relations between Israel and Judah were intimate. See also iii. 1 and ix. 12.

We find that the prosperity mentioned in the historical books has resulted in luxury, dissipation, and the oppression of the poor by the rich, on the part of both men and women, ii. 6, 7; iii. 9, 12; iv. 1; v. 11, 23; vi. 1, 4-6. We further find, throughout the book, descriptions of the religious life of the Northern kingdom, its various sanctuaries, its conformities to the law of Moses and the opposite, that give to the book especial historical interest and value.

To mention only one thing more in this list, the

book is written under the shadow of a threatened and impending invasion from Assyria. To cite a few among many passages, calamity and exile are thus threatened in v. 2, 5, 27; vi. 7, 10; vii. 16, 17; ix. 9. Syria, Ammon, etc., are included in the threat, i. 5, 15, etc. In i. 5, vi. 2, 14, Assyria is pretty distinctly pointed out as the power that will carry these peoples into exile, though it is not directly named.

So much for the historical situation contemporary with the uttering of these prophecies. A very different situation, belonging to an earlier date, is recalled by the prophet in chapters i., ii., and iv. 6-11. Whatever else may be referred to in the first two chapters, the following points are clear: Damascus is named first in the list of threatened nations, the names of Hazael and Benhadad being also mentioned, i. 3-5. The sin especially charged is the "threshing" of Gilbead (cf. 2 Kings x. 32-33; xiii. 7). Ammon and Moab are included among the threatened nations (i. 13-15; ii. 1-3), the sin of Ammon being that "they ripped up the pregnant women of Gilbead, that they might enlarge their border" (cf. 2 Kings viii. 12; xiii. 21, and the Moabite stone). Gaza, Ashdod, Ashkelon, and Ekron are mentioned (but not Gath), i. 6-8, the offence charged being this very peculiar one, that "they caused to go into exile an entire exile-band, shutting [them] up to Edom." Tyre is included, charged with two offences, namely, "their shutting up an entire exile-band to Edom," and that "they remembered not a brethren's covenant," i. 9, 10. Edom directly follows Philistia and Phœnicia in this list, with the charge that he "pursued his brother with the sword," and was implacable in his cruelty, i. 11, 12. In connection with these phrases of brotherhood, as used of Tyre and Edom, note that the charge against Moab is his burning the bones of the king of Edom to lime, ii. 1.

The situation thus outlined is peculiar enough to fix our attention. Apparently, the two Israelite kingdoms have their interests in common; Israel has been in brotherly relations of some sort with Phœnicia and with Edom; Israel and Edom have suffered grievously from the hostile attacks of Moab, Ammon, and Syria—the Syria of Hazael and Benhadad; a change has come, in which Phœnicia and Edom prove false to the brotherly relations, Edom committing bitter hostilities, and Phœnicia and Philistia somehow less directly supporting the hostile acts—"shutting up an entire exile-band to Edom," whatever that may mean. Evidently, these are not the particulars given in the historical books, of Hazael's career, and his great attempt upon Jerusalem; but just as evidently, it is likely that these may be additional particulars of those transactions. As long as Edom, Phœnicia, and northern Israel quietly paid their tribute to the Assyrian, they had so much, at least, in common, distinguishing them from Hazael and his confederates, who were in the habit of making revolts. When Hazael at last made his march from Gath upon Jerusalem, defeating the great army that opposed him, he necessarily sent a crowd of fugitives flying for safety to the neighboring countries. It would be very much like the Edomites, at such a crisis, to break loose from their friendliness, and treat with hostility both the fugitives who came among them, and other men of Israelitish blood. It would not be unlike the Phœnicians and Philistines to aid them in this, or to seek to make gain from them and the Syrians, by affording them a market for their captives and their spoils. Thus understood, the particulars fit so well as to render it probable that this is the true explanation of them.

Our versions render the verbs in Amos iv. 6-11 in the present-perfect tense, as if the situation there described was contemporary with the prophet, thus making the passage difficult to reconcile with all else that is said in the book as to the contemporaneous situation. The verbs should rather be translated by our simple past, *e. g.*:

"And also I, for my part, give you cleanness of teeth in all your cities,
And lack of bread in all your places;
Yet ye returned not unto me, saith Jehovah."

This and the following verses thus allude to notable calamities that God had brought upon the people at some past time not here specified. They mention a calamity of drouth, verses 7, 8, a calamity of blasting and of locusts, verse 9, and then follows:

"I sent among you pestilence in the way of Egypt;
I killed your chosen youths with the sword,
With the captivity of your horses,
And I brought up the stench of your encampments even into your nostrils;
Yet ye returned not unto me, saith Jehovah."

"I made overthrow among you,
Like God's overthrowing Sodom and Gomorrah,
And ye were as a brand plucked from a burning,
Yet ye returned not unto me, saith Jehovah."

It is barely possible that the "way of Egypt" may here mean "after the manner of Egypt," but that is an unnatural translation. By its most simple and natural meaning the phrase is geographical, and we have here a mention of a signal overthrow of the forces of Israel in the region lying toward Egypt. Either the destruction in battle was preceded by a pestilence in the camp, or it is itself called a pestilence. At once we recall to mind that, according to the historical books, Hazael was on his way from Gath to Jerusalem, and, therefore, somewhere "in the way of Egypt" when Jehovah "delivered a very great host into their hand," and also that there is no other recorded defeat of Israel that corresponds to this description in Amos. It is not a necessary part of the view now presented, but is in itself likely that "the very great host" in question was composed of the allied armies of Israel and Judah, and that it was after this defeat that Jehoahaz had left only fifty horsemen, ten chariots, and 10,000 footmen (2 Kings xiii. 7). There may be a connection between the disproportionately small number of horses left to Jehoahaz and the fact described in Amos in the noticeable phrase, "with the captivity of your horses."

It seems to be true, therefore, as we should have expected to find it, that the career of Hazael was still remembered with especial distinctness in the times when Amos prophesied, and that several additional particulars in regard to it are preserved to us in the allusions made by this prophet.

The Book of Obadiah.—This book speaks of an event in the past in which Edom wronged Judah, of punishment already incurred for the wrong, and of yet greater punishment in the future. The points mentioned in regard to the wrong to Judah are that strangers took his army captive; that they came into the vicinity of his gates (possibly, that they entered); that they cast lots upon Jerusalem, verse 11; that they "drank" upon the holy mountain, verse 16; that there was "the exile-band of this army to the sons of Israel" among the "Canaanites as far as Zarephath," and "the exile-band of Jerusalem which is in Sepharad," verse 20. Nothing is said about Jerusalem being destroyed or even captured, nor about the land being made desolate, nor about the nation in general going into exile. In these respects there is a sharp difference between Obadiah and the passages in Ps. cxxxvii.; Ezek. xxv. and xxxv.; Lam. iv., and, indirectly, Jer. xlix. In other words, the event here described has not very much in common with the destruction of Jerusalem by Nebuchadnezzar. The particulars agree at least equally well with those of Hazael's expedition. Further, the resemblances between this event and that referred to in Amos are striking. We have the same stress laid upon the fact that Edom was in brotherly relations with Judah, and was false to these, verses 10, 12. In verse 14 we have

the same peculiar phraseology that we found in Amos: "and shut thou not up his survivors in a day of distress." But the phrase, obscure in Amos, is here intelligible, being interpreted by the parallel line, "And stand thou not at the fork of the road to cut off his escaping ones." In Amos Edom is associated with Philistia and Phœnicia, and the same is true, though less distinctly, in Obadiah, see verse 19, and "Canaanites as far as Zarephath," verse 20. From Obad. 7 it appears that Edom's allies used him for their own advantage, got him out to the border, deceived him, made his bread a snare to him—that is, possibly stimulated him to acts of violence by furnishing him a market for spoils and captives; cf. verse 20. The implication is that they did not stand by him after they had thus got him into trouble. With this agrees the fact that, a few years later, when Amaziah took vengeance on the Edomites in Sela (2 Kings xiv. 7; 2 Chron. xxv. 11, 12; cf. Obad. 3), they seem to have stood alone.

It follows that we have no need to pull the text of Obadiah to pieces, and no need to put forced explanations on the fact that Obadiah speaks as if Ephraim, Samaria, the house of Joseph (verses 18, 19), existed in his time side by side with Judah, in order to reckon the phenomena of the book with its supposed reference to the taking of Jerusalem by Nebuchadnezzar. The reference is not to the Babylonian monarch, but to Hazael. The Book of Obadiah gives us the following particulars connected with Hazael's invasion, in addition to those stated or alluded to in the historical books and Amos: There was a scene of drunken revelry and gambling in the vicinity of Jerusalem, verses 16a, 11c; bands of captives were sold into exile by way of the Phœnician coasts, or sent to Sepharad (Sardis, perhaps), verses 14, 20; Edom claimed, by way of justification, some right of retaliation for some previous injury, verse 15.

These considerations seem to fix the date of the prophecy as after Amaziah's revenge upon Edom, and at a time when there was cordial feeling between Judah and Israel; that is, either just before Joash of Israel beat Amaziah and broke down the walls of Jerusalem (2 Kings xiv. 8-14), or some years later than that event, probably the former.

The Book of Joel.—This book, like Obadiah and unlike Amos, is distinctly Judaite, being even more so than Obadiah. It consists of a single discourse, and therefore belongs to a single date. Probably no one would dispute that its affiliations with Obadiah are such as to prove the two books to be of about the same date.

The careful reader will observe that the argument mainly depended upon, in the article in the *ENCYCLOPEDIA BRITANNICA*, to prove that Joel is post-exilic is drawn from the fact that Joel evidently presupposes the priestly legislation of the Pentateuch, and must, therefore, have been written later than that legislation. To one who is already convinced that the priestly legislation is post-exilic the argument is decisive; but really it is bad reasoning first to argue that the priestly legislation is post-exilic because it is only mentioned in post-exilic books, like Joel, and then to infer that these books are post-exilic from the fact of their mentioning the priestly legislation.

The historical situation recognizable in Joel is mainly that of a related group of recent calamitous events. Verbally, the calamities mentioned are three—a drouth, i. 10-13, 15-20; a locust plague, i. 4-9; ii. 1-11, and a subjugation to enemies. In this Joel is parallel with Amos iv. 7, 8, 9, 10, 11. Whether we regard the drouth and the locust plague as separate facts or as figurative modes of expression for the invasion by enemies, in any event the invasion is the most prominent fact contemplated in the descriptions, the threats, and the promises of the book. The situation is peculiar, is pretty distinctly outlined, agrees in some particulars with the situation of the invasion of Hazael, as

presented in the historical books, and in Amos and Joel, and is in no particular inconsistent with that situation.

It was a time when strangers were passing through Jerusalem, iv. 17 (iii. 17); when Jehovah's inheritance was being dominated to its reproach by the nations, ii. 17-19; when they had apportioned Jehovah's inheritance, scattered Israel among the nations, and reduced the population of Jerusalem to an escaping remnant, iv. 2 (iii. 2); iii. 5 (ii. 32); cf. Obad. 17. Joel nowhere uses any word of the stem נָזַח , and, properly understood, nowhere speaks of the nation as being in exile; but he speaks of a condition of captivity, either past, present or future, from which Judah needed restoration, iv. 1 (iii. 1). Like Obadiah, he speaks of a scene of revelry, when Jewish captives, boys and girls, had been sold cheap to satisfy the demands of drink and lust, or had been gambled for, iv. 3 (iii. 3); cf. Obad. 11. In these injuries Edom and perhaps Egypt had participated, doing violence to the sons of Judah, and shedding innocent blood in their land (perhaps the blood of Jewish fugitives shed in Edom), iv. 19 (iii. 19); cf. Obad. 10. Tyre, Sidon, and Philistia, under pretence of retaliating upon Jehovah for something (say for the fate of Jezebel and Athaliah), had taken their part in the affair, iv. 4 (iii. 4). Perhaps in the way of trade for spoils they had brought in Jehovah's silver and gold and delightful things into their palaces, iv. 5 (iii. 5); they had sold Jewish captives as slaves to the Greeks long distances away, iv. 6 (iii. 6); cf. Obad. 20.

Joel describes the principal agent of subjugation as "the northerner," ii. 20. His occupation of the country is not permanent, but he is driven out into a dry and desolate country, and his stench ascends. His going is with his face to the eastern sea, and his rear toward the hinder sea; that is, perhaps, from the vicinity of Jerusalem, out of the country in an easterly direction. At first thought this might seem inconsistent with the referring of the passage to Hazael, since the account in Kings seems to represent him as leaving the country in triumph, bearing with him the spoils of the temple, which had been given him to bribe him to leave. But why did Hazael content himself with thus receiving a part? Now that Jerusalem was at his mercy, why did he not take the whole? Combine the suggestion in these questions with the possibility that the interference of Rimman-nirari occurred at this point of time, and with the fact that the power of Syria so soon afterward went down before that of Israel, and we see that this part of Joel's description may very probably be true of the invasion by Hazael.

If the reference is to this event, it fixes the date of the Book of Joel. It belongs within the lifetime of the men who had witnessed the event, i. 2, while some of the captives then taken were yet living, with the promise of returning to their native country, iv. 7 (iii. 7), cf. Obad. 20.

Joel elaborates a doctrine of the day of Jehovah, in which Jehovah will judge the nations; Obadiah and Amos cite this doctrine as something already known, e. g., Obad. 15; Amos v. 18. From this and other circumstances, it is to be inferred that Joel was first published, then Obadiah, then Amos, and that the citations of one from the other are to be interpreted accordingly. Joel and Obadiah were prophets, by whose word concerning Jehovah's day of judgment for the nations Jeroboam and Uzziah were encouraged in the efforts by which they established their power from Hamath to the sea of the Arabah, and thus became the "saviours" Jehovah promised, Obad. 21; 2 Kings xiii. 5; while Amos prophesied a few years later, against the sins that were rife, in spite of Jehovah's graciousness.

The Book of Jonah.—According to the statement made in 2 Kings xiv. 25, Jonah prophesied before the victories by which Jeroboam II. restored the glories of

Israel. He belongs, therefore, with Joel and Obadiah; though, unlike them and Amos, he was a northern Israelite. It is possible that he was the earliest of the four, and therefore the earliest of the prophets who have given their names to the prophetic books.

The Book of Jonah is thoroughly recognized both in the New Testament and in tradition, as well known and as scriptural, and hence as having whatever authority of inspiration belongs to any book of Scripture. This fact, and, along with it, the religious teachings of the book, should be carefully guarded, no matter what questions may arise in regard to its authorship, or the settling of the difficulties it presents.

We now resume our study of the history. Unless reasons can be given for some different interpretation, the Biblical numerals make the interval between the death of Jeroboam II. and the destruction of Samaria to be seventy-four years. The chronology adopted in the BRITANNICA's article on HOSEA would reduce this nearly one-half, while still other different views of the matter have their advocates. These differences cannot here be discussed; it is sufficient to say here that the numerals given in the BRITANNICA are merely tentative; the failure of any one of half a dozen conjectures would leave them groundless; there is reason here for careful inquiry into all items of evidence that may throw light upon the Biblical numerals and statements, but no reason, as the evidence stands, for rejecting or suspecting these.

In any case the death of Jeroboam was followed by anarchy in northern Israel. Probably there was an interregnum before the accession of his son Zechariah, and certainly Zechariah, after reigning only six months, was slain by Shallum, who, in turn, was in a month dethroned and slain by Menahem. The ten years of Menahem extended from the thirty-ninth of Uzziah to the forty-ninth. In the early part of it, apparently, Pul, king of Assyria, invaded the land, and Menahem paid him a thousand talents "to confirm the kingdom in his hand." To this date, most likely, belongs the deportation of the tribes east of the Jordan, mentioned in 1 Chron. v. 6, 26. That Pul was Tiglath-pileser seems to be generally accepted, but a comparison of the Biblical dates with the Assyrian shows it to be probable that these transactions occurred before he became king of Assyria. An Assyrian account of them probably exists, in the shape of the fragmentary inscriptions mentioned above, conjecturally attributed to Tiglath-pileser. These mention Menahem as paying tribute, and Uzziah as the chief of an anti-Assyrian confederacy.

Menahem was succeeded by Pekahiah, and he by Pekah, whose first year was the last year of Uzziah. Uzziah was succeeded by Jotham, and he by Ahaz, who came to the throne in the seventeenth year of Pekah. By this time the combination of peoples which had constituted the empire of Jeroboam II. and Uzziah was broken up, and the unity of Israel and Judah was also broken. Pekah joined Rezin of Damascus in war against Ahaz; Ahaz became tributary to Tiglath-pileser, and asked help from him; he conquered Damascus, and deported its citizens, and captured several cities of the north of Israel, deporting their inhabitants, 2 Kings xv. 29. Apparently this is a different deportation from that of the trans-Jordanic people, 1 Chron. v. 26. These transactions are narrated somewhat in full in the Assyrian records, Tiglath-pileser, Ahaz, Rezin, and Pekah being mentioned by name.

The Book of Hosea.—According to its inscription Hosea prophesied in the times of Jeroboam II. and of Uzziah, Jotham, Ahaz, and Hezekiah, of Judah. Of the prophecies contained in this book the earlier antedate the death of Jeroboam, but, perhaps, none are later than Uzziah. The historical situation exhibited in the earlier prophecies of Hosea is the same with the contemporary situation as shown in Amos; the

later parts of the book often directly mention Assyria, and represent Israelitish public men as in a state of perpetual intrigue with Assyria and with Egypt, *e. g.*, v. 13; vii. 11, 16; viii. 9; ix. 3, 6; x. 6; xi. 5; xii. 1; xiv. 3. The violent changes in the monarchy are also alluded to in such passages as viii. 4 and xiii. 11. The absence of elements like these from Amos, Obadiah, and Joel, and their presence in Hosea, are facts that enable us to fit the dates of these prophecies very closely to those of the history.

The Earlier Prophecies of Isaiah.—The points in the treatment of Isaiah which especially need notice have already been considered in the article on ISAAIAH. The parts of Isaiah which we naturally assign to the reign of Uzziah are the three prophecies contained in chaps. ii.–vi. The historical situation here ought to agree with that in Hosea, and the agreement actually exists, if we make due allowance for the fact that Isaiah is essentially a Judaite prophet, and Hosea a Northern prophet. The Book of Isaiah, chaps. vii.–xii., is made up of prophecies of the time of Ahaz. In them the invasion of Pekah and Rezin and the Assyrian intrigues and movements of the time are especially prominent.

The Prophecies in Zechariah ix.–xiv.—The relation of these chapters to the earlier chapters of the Book of Zechariah will be considered in its proper place. For the present we have to notice the historical situation presented in them. Chaps. ix.–xi. are a discourse entitled "The Burden of the Word of Jehovah in the Land of Hadrach," while chaps. xii.–xiv. are entitled "The Burden of the Word of Jehovah upon Israel."

In the first of these two discourses the following are among the noteworthy points: "Hadrach" occurs only here in the Bible. The name is used about in the same way with such names as Hamath, Damascus, Samaria, in the Assyrian inscriptions, in connection both with Menahem and with Pekah. The time of the prophecy was during the Assyrian period, x. 10, 11. It was when the kingdoms of Israel and Judah were both in existence, that is, before the downfall of Samaria, ix. 10, 13; x. 6; xi. 14. According to the traditional translation of ix. 2 it was a time when Hamath was the border of Israel, and therefore before the empire of Jeroboam II. had utterly gone to pieces. Like Joel and Amos, this discourse groups together Tyre, Sidon, Ashkelon, Gaza, Ashdod, and Ekron, as having certain relations with Judah, but, unlike them, omits Edom, ix. 1–8. Like Joel, it has something to say concerning the Greeks, ix. 13. A short time previously there had been in existence "my covenant which I made with all the peoples," and this covenant had now been broken, xi. 10. There had also been "brotherhood," now broken, between Judah and Israel, xi. 14; cf. ix. 10, 13; x. 6. The "exacter" has been passing through upon the temple at Jerusalem, perhaps by way of Philistia, ix. 8; x. 4. Apparently, there has been a great recent defeat of Ephraim and Judah combined, ix. 10. (Translate thus: "And though I cut off chariot from Ephraim, and horse from Jerusalem, and battle-bow be cut off, yet he shall speak peace," etc., cf. Hos. i. 7; ii. 20 [18]), the prisoners being now confined in dry wells and such places (ix. 11, 12). Israelites from Gilead and Lebanon have been sown among the peoples, and their return is promised, especially from Assyria and Egypt (x. 8–12; cf. Hos. vii. 16; ix. 3–6). The Israelites are now the "flock of slaughter," and therefore "the most miserable of sheep" (xi. 4, 7), especial emphasis being laid upon certain mercenary transactions by which they became so (xi. 5; cf. Hos. viii. 9; 2 Kings xv. 19). It is a time of bad "shepherds," and of the cutting off of shepherds (x. 2, 3; xi. 8, 16, 17). On the whole the situation is pretty sharply that of the later years of the reign of Uzziah, either shortly before or shortly after the death of Menahem.

The discourse concerning Israel, Zech. xii.-xiv., is, notwithstanding its title, exclusively concerned with Judah. It is late enough in date so that it can refer to the earthquake in the days of Uzziah as a thing of the past, but early enough so that people then living had fled from the earthquake (xiv. 5). That is to say, it is a generation later than Amos (Amos i. 1). It is enough later than the previous discourse so that the attitude of the surrounding peoples, then somewhat undecided, has now become one of positive hostility (xii. 2; xiv. 12, 16, etc.) In fine, it contemplates a condition of things like that of the reign of Ahaz, as delineated in Kings, Chronicles, and Isaiah vii.-xii.

The prophets of this earliest group all preach, prominently, the doctrine of "the day of Jehovah." In Joel and Obadiah it is mainly a day of judgment for the nations and of rescue for Israel. In Amos, Hosea, Isaiah, and Zechariah it is the same, but is also a day of judgment for Israel, a day of dread, as well as a day of gladness. It would be a mistake, in any of these prophets, to refer it to any particular event in such a way as to exclude its application to other events. It is an eternal judgment day, always impending, and perpetually repeating itself. The conception of it in the minds of the prophets, from Joel onward, is large enough to include and justify the largest New Testament use of their language.

Even more prominently than their preaching of the day of Jehovah these prophets preach the covenant promises made to Israel. In connection with this they all allude very abundantly to the events, the institutions, and the phraseology of the various parts of the Pentateuch.

Beginning with Amos, they preach the promises made to David, combining this in their preaching, with the doctrine of the day of Jehovah, and the promise to Israel, *e. g.*, Amos ix. 11; Hos. iii. 5; Isa. ix. 7; Zech. xii. 7, 8, 10, 12; xiii. 1. The Israelite prophets are as distinct in this as the Judaite. Here again the person mentioned is commonly not some particular king of the house of David, but the seed of David as promised, an eternal seed, including, of course, all particular kings in the line, but always anticipating something yet greater in the future. It is true to the stirring scenes in which these prophecies were uttered that they sometimes make splendid promises of victory won in battle, over Israel's enemies, *e. g.*, Zech. ix. 13-16. But far more prominently they insist upon the sway of the seed of David as that of a prince of peace, having universal dominion, *e. g.*, Zech. ix. 9, 10; Isa. ix. 6, 7; xi.; ii. 2-4, etc. This conception of these prophets stands out in striking contrast with the scenes by which they were surrounded.

The Prophets of the Later Assyrian Period.—These are Isaiah, Micah, and Nahum. In the sixth year of Hezekiah, the political power of the Northern kingdom was finally extinguished by Sargon, king of Assyria. Sargon was succeeded on the throne by his descendants Sennacherib, Esar-haddon, and Assurbanipal. Hezekiah was succeeded by Manasseh, Amon, and Josiah. For most of this period the Assyrian records are abundant and throw great light on the Bible. The chronology of these records synchronizes very closely with that of the Bible, rightly understood, though the contrary is sometimes asserted.

According to Mic. i. 1, Micah prophesied in the days of Jotham, Ahaz, and Hezekiah. Those of his prophecies that are recorded, however, all belong to the days of Hezekiah, and mainly to the six years of Hezekiah's reign that elapsed before the downfall of Samaria, *e. g.*, i. 6; iii. 12; Jer. xxvi. 18. From the rebukes uttered by Isaiah and Micah at this period, Prof. W. Robertson Smith in the article in the *ENCYCLOPEDIA BRITANNICA* infers "the conclusion that Hezekiah was not from the first a reforming king," as the accounts in Kings and Chronicles represent him to have

been; but the premises justify no such conclusion. If Hezekiah was from the first a reformer, it does not follow that he would be able by a pen-stroke instantly to annihilate the evils of the times, so that there would no longer be these evils to rebuke. It is more natural to think that there would be a struggle, and that he would need all the aid these prophets could give him in carrying out his purposes of reform. The alleged contradictions between Isaiah and Micah, and between Mic. iv. 9, 10 and iv. 11-13, are not contradictions, but the presentation of different aspects of the same fact. When we remember that Tiglath-pileser and the kings of the Sargon dynasty claimed it as a special glory that they were kings of Babylon as well as of Assyria, and that some of the immigrants to Samaria were brought from the Babylonian regions, we see that there is nothing in the words, "thou shalt come even to Babylon," Mic. iv. 10, to justify the charge of interpolation, or of the presence of a later hand than Micah's. The idea that Mic. vii. 7-20 is post-exilic is sufficiently refuted by the mention of Assyria in verse 12, and the alleged difference of situation between chaps. vi.-vii. and the previous chapters does not exist except on the assumption that people of different characters cannot live in the same country at the same time.

Nahum is not formally dated. As it consists largely of threats against Assyria, it evidently belongs to the Assyrian period. If it were necessary to refer iii. 8-10 to the taking of Thebes by Assurbanipal, that would prove the prophesying of Nahum to have been in the latter part of Manasseh's reign, or later, but the sacking of Thebes referred to may be an earlier event. Josephus says, very circumstantially, that Nahum's prophecy was uttered in the reign of Jotham, 115 years before the fall of Nineveh (*Ant. IX.*, xi. 3).

The Prophets of the Babylonian Period.—These are Zephaniah, Habakkuk, and Jeremiah in Palestine, and Ezekiel in Babylonia. No one knows just when the downfall of Nineveh occurred, but the power of Nineveh in Palestine evidently ceased from early in the reign of Josiah. The first three of the prophets just named began to prophesy in the interval between the loosening of the hold of the Assyrian over Judah and the rise of the Babylonian supremacy. The Book of Zephaniah is, like Joel, a monograph on "the Day of Jehovah." It is best regarded as consisting of three parts—a threat of judgment, i.; an exhortation to repentance, ii. and iii. 1-8, and a promise of salvation, iii. 9-20. It is dated "in the days of Josiah," i. 1. Havernick, Ewald, De Wette, Jahn, and others regard it as belonging to the first eleven years of Josiah's reign, the years before his reformation begun. Keil, Witsius, V. Coeln, Knobel, Hitzig, E. Meier, Strauss are quoted as assigning it to the middle seven years of Josiah, the years when his reformation was in progress, and Delitzsch, Bertheau, Klein, and Kleinert, as assigning it to the later years of Josiah, after the reformation had become an accomplished fact. The evidence can hardly be regarded as decisive in favor of either view. Such passages as i. 4, 6, seem to imply that there had recently been a reformation, which had reduced the worshippers of Baal to a remnant, and that still more recently there had been some apostasy on the part of those who had reformed. If it were certain that the reformation here referred to is that of Josiah, that would be decisive as to the date of the book; but this reformation is quite as likely to be that of the later days of Manasseh, 2 Chron. xxxiii. 12-17, with the apostasy that followed in the days of Amon. Taking this view of the matter, there is a preponderance of probability in favor of the opinion that Zephaniah prophesied early in Josiah's reign, and that we have here one of the discourses by which public opinion in Judah was influenced in favor of undertaking the reformation.

Concerning Habakkuk, it need here only be noted that this prophecy is dated by its affiliations with Zeph-

aniah and Jeremiah, as belonging, probably, to the later years of Josiah.

The Book of Jeremiah, as it now exists, is more fully provided with a system of titles and sub-titles than any other book of the Old Testament. Following these, or classifying by them, the book consists of five parts: The first part, chaps. i.-xx., contains six collections of sketches of prophecies (i. 4-iii. 5; iii. 6-vi.; vii.-x.; xi.-xiii.; xiv.-xvii.; xviii.-xx.). Each collection includes several sketches, some of the prophecies being sketched in a sentence or two, and others given quite in full. The sketches mingle poetry and prose in the most unexpected ways, and are remarkably uneven, both in literary character and in the topics discussed. The first two of these collections are dated as belonging to the reign of Josiah; the third is identified in chap. xxvi. as containing the group of prophecies for which Jeremiah was prosecuted early in the reign of Jehoiakim; the other three are not dated. The second part, chaps. xxi.-xxxvi., is a series of dated narratives and addresses, each complete in itself, in an order which seems to be entirely miscellaneous. The third part, chaps. xxxvii.-xliv., is a continuous narrative of the times of the destruction of Jerusalem by Nebuchadnezzar, including some discourses. The fourth part, chaps. xlv.-li., is a collection of poems, which might be entitled "The Book of Woes upon the Nations." The poems contained in it are of different dates, but they have a common character. The fifth part is the historical appendix, chap. lii. Whatever there may be that is puzzling in the present order of the book, it seems at least to be clear that the man who put the book together had in his possession the first, third, fourth, and fifth parts, each complete in itself, and also the various discourses that compose the second part; he first arranged the completed parts, in the order which was on the whole the most natural, and then put the remaining separate discourses in the place where, as a whole, they belonged, without arranging them, relatively to one another, in the order of time.

The first collection of the first part of Jeremiah contains sketches of five different prophecies, each introduced by the formula, "And the word of Jehovah was unto me, saying." The five sketches are i. 4-10, 11, 12, 13-19; ii.; iii. 1-5; the introductory formula being incomplete in our text in iii. 1. Here and in the following collections it is at once evident that we have not, ordinarily, the full text of each prophecy, written out in the words in which the prophecy was originally uttered, but a mere sketch of the prophecy, made for some purpose, at a later date. What should we expect to find different from these collections, if we could recover the roll said to have been written by Baruch, Jer. xxxvi. 32? The different roll mentioned in xxxvi. 2-26, the roll which the king destroyed "when Jehudi had read three or four leaves," can hardly have been so brief a document as Graetz supposes, when he says that it was merely the prophecy now found in chap. xxv. A resumé of the prophet's utterances for many years would give weight to his testimony, even if it included much besides direct threatenings as to what the king of Babylon would do to Judah. It is not good reasoning to substitute conjecture for testimony, in cases where there is no more difficulty with the testimony than there is here.

In the argument as to the authorship of Jer. lii., it should be kept in mind that the accession of Evil-merodach was but sixty-six years after Jeremiah began to prophesy, he being then a "child" (i. 6). We have no information as to how long Jeremiah lived. It is true that Ezekiel was his "late contemporary," but we do not know which of the two died first, and most of the Book of Ezekiel is dated either before the destruction of the temple, or very soon after that event, that is to say within the probable lifetime of Jeremiah.

The article on EZEKIEL in the ENCYCLOPÆDIA

BRITANNICA includes a good many dates from the Christian era, given according to the commonly accepted scheme of chronology. If any one will take the trouble to compare the Biblical dates with those of the Canon of Ptolemy, and will do the work correctly, he will find that all these dates are too large by two; that is, for example, the date of the exile of Jehoiachin was B. C. 597, instead of B. C. 599. The difference is important, not for the times of Ezekiel only, but for all dates concerning the prophets, or concerning the history, back to the time of the downfall of Samaria. For all this period, the dates B. C. accepted by the Assyriologists are based on the Canon of Ptolemy. As a matter of fact, if we reduce the Biblical dates to the same standard, we transform many a supposed general and vague synchronism between the Biblical and the Assyrian records into an exact synchronism.

The connecting of Ezekiel's forty years with his frequently repeated prophecies of the restoration of Judah is, it should be remembered, a matter of interpretation, and not of direct statement by him. Whatever may be true as to Kuenen's having proved the traditions concerning the Great Synagogue to be unhistorical, no history is more veritable than much of the tradition concerning Ezra, Nehemiah, and some of the other men who are often called "the men of the Great Synagogue;" and it is the traditions concerning the men, and not those concerning the organization, that are mainly important as evidence in regard to the completing of the Scriptures. According to the traditions, Ezekiel's contemporaries, Daniel, Shadrach, Meshach, and Abed-nego were among the men of the Great Synagogue. Ezekiel himself is likely enough to have been one of the number. There is no reason for doubting the essential fact in the tradition concerning Ezekiel, namely, that the men of the Great Synagogue are responsible for its existence as a literary work.

As to the relations of Ezekiel to the Pentateuch, his holy land, holy city, temple, and ritual are all largely symbolical, for they are full of specifications that are palpably impossible, if we try to understand them as literal facts; the strong literary resemblances between Ezekiel and certain parts of the Pentateuch are readily accounted for by the fact that the prophet was evidently a man of narrow reading, whose style was greatly affected by those writings to which he paid especial attention; Ezekiel is distinguished from every part of the Pentateuch, by the fact that the Babylonian *locus* of the author never for a moment disappears from Ezekiel, and never sharply appears in the Pentateuch; and by the fact that Ezekiel throughout presents linguistic peculiarities different from those found in the Pentateuch. The relations of Ezekiel to the Law are admirably discussed by Dr. Frederic Gardiner, in the *Journal of the Society of Biblical Literature and Exegesis* for 1881.

The Post-exilic Prophets.—These are Haggai and Zechariah, each containing several short prophecies, dated by certain days of certain months in the reign of Darius Hystaspes, and Malachi, dated by its contents, its position in the canon, and tradition as from the latest period of the Old Testament canon, that is, from the latter part of Nehemiah's second administration in Jerusalem. By the plan on which the present articles are written, these books require no extended notice. Any reader who will carefully examine the references given in the article on HAGGAI in the ENCYCLOPÆDIA BRITANNICA will see that, really, there is no conflict between the statements made in Haggai and those made in Ezra, as to the restoration of the temple, but that, on the other hand, the prophecies of both Haggai and Malachi presuppose that the builders had had especial hindrances and difficulties, and that the hindrances mentioned in Ezra exactly fit the case.

We have already noted the fact that the two prophecies in Zech. ix.-xiv., although they immediately

follow eight chapters dated in the reign of Darius, yet present distinctly the historical situation of the times of Uzziah and Ahaz. This would be accounted for if we suppose that two independent books have here been arbitrarily joined, or if we suppose that the Zechariah of the times of Darius wrote both, but, in writing ix.-xiv., put himself back to the point of view of the earlier time, or if we suppose that he possessed the earlier work, and edited it into his own book, or very likely in other ways. Among the various possible theories, it is not necessary here to decide; with the facts clearly in mind, the question as to how the facts are to be accounted for is a question that can wait.

The present writer, having in mind the fact that this article is to be supplementary to those in the *ENCYCLOPÆDIA BRITANNICA*, has regarded it as ordinarily unnecessary to repeat the details that are given, and often admirably given, in those articles. Nor has he regarded it as his duty to controvert every point in which those articles present views different from those held by most American evangelical scholars. Much less has he attempted the limitless task of arguing all such questions. The reader who really desires to get at the truth should carefully look at the evidence for himself, on both sides of these controverted questions. But there is one line of statements that requires a brief additional consideration. In regard to nearly every one of the prophetic books the reader will observe that the various writers in the *BRITANNICA* make two affirmations: first, that the text is corrupt, containing errors and interpolations, and needing emendation; secondly, that the book shows marks of having been worked over, changed from its original form by additions, omissions, and the piecing together of parts that originally did not belong together. In the instances where these writers are cautious and avoid these affirmations, some other living writers are less cautious; there is probably no prophetic book, and indeed no book of the Old Testament, in regard to which a certain class of critics do not confidently assert both that the text is in need of emendation, and that the book has been worked over since it was written. These points are raised in connection with a multitude of instances throughout the prophetic books; it has been impossible to notice the instances separately as they arose, and is now impossible to discuss the points at length. But by all fair laws of critical reasoning, most of the instances are mistakes, and, in general, the inferences drawn from them are not well drawn. All questions of this sort have a right to be examined and decided by the evidence. But presumptively, phenomena that characterize every part of a literature are to be regarded as the ordinary phenomena of that literature, and not as marks of text-corruption or of complicated redaction. In the books of the prophets, the fair application of this principle will sweep away nearly all the alleged instances of these.

Literature.—Among accessible commentaries that treat of the prophetic books, those of the Lange series and those of the Keil and Delitzsch series are full and valuable. The successive volumes of the *Cambridge Bible for Schools* are highly prized. The successive issues of the *Old Testament Student* from January, 1888, contain notices of the prophetic books with references to the literature; and the same periodical has for some years published a monthly list of publications concerning the Old Testament, including, of course, the prophetic parts of it. Dr. W. H. Green's book, *Mosaics and the Prophets*, includes reviews of the volumes of Kuenen and of W. Robertson Smith. Orrell's book on *Old Testament Prophecy* has attained wide celebrity. An especially valuable compact discussion of the most important questions concerning the prophets and prophecy is contained in several of the lectures in *The Old and New Testaments in their Mutual Relations*, by the Rev. Frederic Gardiner, D. D. *Messianic Prophecy*, by the Rev. C. A. Briggs, D. D., is fresh and brilliant, and of very great value for many purposes. The various Bible Dictionaries and Religious Encyclopædies contain full lines of articles on these subjects, with lists of the literature; the literary lists in the *Schaff-Herzog Encyclopædia* are especially rich. (W. J. u.)

PROTECTION. See **FREE TRADE** and **POLITICAL ECONOMY.**

PROVERBS, BOOK OF. See **SOLOMON.**

PROVOOST, SAMUEL (1742-1815), bishop of the American Episcopal Church, was born in New York city, March 11, 1742, being of Huguenot descent. After graduating at King's (now Columbia) College in 1758 he went to England, studied, and graduated at Cambridge University, and was admitted to orders in 1766. Returning to New York he was made assistant minister of Trinity Church, but in 1770 retired to a farm in Dutchess county. During the Revolution he favored the American cause, but took no active part. On the evacuation of New York by the British in 1783 he became rector of Trinity Church, and in 1785 he was chaplain to the Continental Congress. In 1786 he was elected bishop of New York, and in company with Dr. William White, who had been elected bishop of Pennsylvania, went to England and was consecrated at Lambeth palace, Feb. 4, 1787. Returning to New York, he continued his work as rector of Trinity Church until 1800, when he resigned on account of his infirm health. He also resigned his bishopric in the next year, but the resignation was not accepted, though Rev. Dr. Benjamin Moore was chosen his assistant. Bishop Provoost died Sept. 6, 1815.

PRYOR, ROGER ATKINSON, Confederate general and lawyer, was born near Petersburg, Va., July 19, 1828. He graduated at Hampden-Sidney College in 1845, and at the University of Virginia in 1842. He was admitted to the bar and was also active in journalism in Petersburg, Washington, and Richmond. In 1854 he was sent as a special commissioner to Greece. In 1857 he was elected to Congress, where he threw all his youthful ardor into the advocacy of extreme Southern claims. A noted incident of his career as representative was his challenge of John F. Potter, of Wisconsin, who selected bowie-knives as the weapons, but no duel was fought. Pryor joined Gen. Beauregard's staff at the attack on Fort Sumter. On the secession of Virginia, he was sent as delegate to the Confederate Congress, but he soon entered the army with the rank of colonel. He was promoted brigadier-general in 1862, and led a division in the defence of Richmond against McClellan. He resigned from the army in August, 1863, and being taken prisoner in November, 1864, was confined for a short time in Fort Lafayette, in New York harbor. Since the close of the war he has been a lawyer in active practice in New York city.

PSALMS. "As regards the dates and historical interpretation of the Psalms, all older discussions, even those of Ewald, are in great measure antiquated by recent progress in Pentateuch criticism and the history of the canon." This statement, taken from the last sentence of Prof. W. Robertson Smith's article on the **PSALMS** in the *ENCYCLOPÆDIA BRITANNICA*, defines his point of view. The psalms which by their titles, their apparent contents, and external testimony, are attributed to David and his contemporaries, contain hundreds of allusions to the various parts of the Hexateuch. If any considerable number of the psalms were actually written in the times of David, then the whole Pentateuch had been previously written. But if the view of Pentateuchal criticism presented in the successive volumes of the *BRITANNICA* is correct, then most of the psalms are not only post-Davidic, but post-exilic, and the completion of the Psalter cannot have been earlier than the Maccabean times. It is well to have this issue sharply presented. But unless one assumes that the post-exilic origin of the Hexateuch is a proven fact, the reasons are very weak for assigning a majority of the psalms to a date later than David, or any of them to a date later than Nehemiah.

It is conceded that the contents of a psalm may have more weight, as evidence of its date, than any external evidence that can ordinarily be cited. Ps.

cxvii., for example, with its picture of the children of Zion weeping by the rivers of Babylon, was evidently written after the beginning of the Babylonian exile, and apparently within the lifetime of some of the very persons whom Nebuchadnezzar had carried away. And this case shows us what we are to expect in other cases. The writers of the Psalms were not men who took pains to cover up the signs of the date when a psalm was written. If a psalm is really of late date, it is likely, in most cases, that there will be, as there is in Ps. cxvii., some evident and distinct sign of that fact. The absence of such signs has weight against attributing a late date to a psalm. But if any one will take pains to examine the reasons that are given when it is proposed to assign an apparently Davidic psalm to later ages, or any psalm to a date later than Nehemiah, he will find that the reason, in most instances, is not very distinct or very strong; in many instances it is as attenuated as possible.

The fact, for example, that a psalm mentions the temple or its service is no strong proof of its having originated later than David. To say nothing of the earlier temple of Eli's time, the accounts of the reign of David inform us that he and other devout Israelites used much time and treasure, making preparations for the temple that was to be built by his successor, and arranging for its services. Nothing could be more natural, during this period, than that a sacred poet should look forward to the times when the proposed building and its ritual should be in existence, mentioning them in his song.

Nor is a psalm proved to be of post-exilic origin by its speaking of Israel as in distress, or as needing to be saved, or even of Israel as scattered among the nations. At half a dozen different periods between the reign of David and the Babylonian exile the history of Israel or Judah was such that language of this sort would be appropriate. During the later years of Saul, and the earlier years of David, there was a period of this sort; witness the battle of Gilboa, and, later, the two desperate attempts of the Philistines against David, after he took the throne of all Israel. War always means the driving of people as fugitives from their homes; wars in ancient times involved the selling of the conquered into slavery. Nothing could be more superficial than to regard every expatriated Israelite spoken of in the Bible as an exile of Nebuchadnezzar's time. There never was a century of Israelitic history that had not its own cases of this sort.

Nor is a psalm proved to be post-exilic by the fact of its containing Aramaic or Syriac peculiarities of language, nor even by its containing peculiarities that are also found in prose in the later Hebrew. No fact is more familiar than that the poetic forms of a language, or of one period of a language, are apt to show affiliations with the prose forms of some cognate language, or of some different period. The colloquialisms of one language or period correspond to the literary usage of a cognate language, or a different period. The times of David were times when the Israelites were rapidly changing in culture, and largely through the fact of their having conquered certain Aramaean peoples more cultured than themselves. In the circumstances, the literature of the times of David ought to show the marks of the times. And later, in the times of Benhadad, Hazael, and the successive Assyrian conquerors (see 2 Kings xviii. 26), there existed facts that might easily account for linguistic peculiarities of this sort.

Nor is a psalm proved to be non-Davidic by its not having a title, in the Hebrew, attributing it to David. We have no sufficient knowledge as to the origin of the titles to justify any inference of this sort. It is easy to say that the collectors of the psalms would naturally ascribe a psalm to David, if they knew of the least shred of evidence to justify them in doing so; and that their failing to do so therefore shows that no evidence existed in their day; but of this we have no proof.

As a matter of fact, several of the psalms that are most specifically attributed to David in the New Testament and in the Books of Chronicles are those that have no titles.

A psalm is not necessarily proved to be of late date by agreements of its phraseology with that of passages in the later books. Nothing could be more natural than that the authors of these later books should quote the psalms. Nothing could be more natural than that they should be so familiar with the national sacred songs that their own phraseology should be influenced thereby, even when they made no formal quotations.

The positive proof that a majority of the psalms date from the lifetime of David and of men who were contemporary with him, that a large proportion of the rest are pre-exilic, and that none are later than the possible lifetime of Nehemiah, includes many different items, and applies differently to different psalms. Of course it is possible here to consider this evidence only in general.

The Testimony of the Hebrew Titles.—To begin with, the Hebrew titles of about ninety psalms (the same titles that are found in the English versions) contain the name of David or of one of his contemporaries, Asaph, Heman, Ethan (or Jeduthun), or Solomon. Save in a very few instances these titles are corroborated by the Septuagint, and the various copies of this version also prefix the name of David to a considerable number of the psalms where it is not found in the Hebrew. It is not necessary, in all cases, to suppose that the man who wrote the title intended to be understood that the man named in the title is the author of the psalm. Supposably, the words "to David," prefixed to a psalm, might mean, not that David wrote the psalm, but that he is the subject of it, or that it was dedicated to him, or that it was regarded as Davidic in its character, or that it belonged to a collection that was considered as in some sense Davidic; and there are other ways in which a psalm might be regarded as Davidic, though not written by David. Any one who will look up the Septuagint titles to the psalms with care will readily see that, in some cases, the Septuagint writers and annotators did not regard the man named in the title of a psalm as its author. But after making all due allowances of this sort, no one would dispute the statement that, prevailing, the prefixing of a name to a psalm, in its title, was intended as an indication of its authorship. In any given case, therefore, this interpretation of the title is to be preferred until reasons appear for a different interpretation.

But it is said that the titles originated in a later and uncritical age, and are therefore of little value. If it were known that they are of late origin, that would not prove them valueless, but would merely open the way for proving them so; on comparing them with other evidence, external and internal, it might still appear that they were thoroughly trustworthy. But what evidence can any one adduce that the titles are of late origin? This is a thing to be proved, not to be assumed. The titles have been there as far back as we can trace the psalms themselves. In the Hebrew, they are printed with nothing to distinguish them from the rest of the psalm; if a title is long enough to make a verse, it is numbered as the first verse of the psalm, and not, as in the versions, as a separate paragraph. No one has a right to reason from the premises that the titles are some centuries, or some generations, later than the psalms to which they are prefixed, until he has first proved these premises.

But it is said that the titles are inconsistent with the contents of the psalms to which they are prefixed, and are by this shown to be unhistorical. If this inconsistency really exists, in some cases, then it shows that in those cases the title is either erroneous or else is to be understood as indicating something else than the authorship of the psalm. But to justify this, the inconsistency must be clearly made out, not slimly guessed

at. "To refer Ps. lii. to Doeg, Ps. liv. to the Ziphites, Ps. lix. to David when watched in his house by Saul, implies an absolute lack of the very elements of historical judgment." The question which displays the greater lack of historical judgment, the man who wrote these titles, or the man who made this remark concerning them, may safely be left to the decision of any intelligent reader who will read carefully, in each case first the passage referred to in Samuel, in its full connection, and then the psalm referring to it. In none of the cases does the psalm contain a description of the incident referred to, so that some later editor would be likely to identify the psalm with the incident; but in each case the psalm delineates thoughts and feelings such as might naturally arise from the incident, in an earnest, religious young man, who held somewhat large views in regard to God's purposes with Israel.

"There is a whole series of hymns in which the writer identifies himself with the poor and needy, the righteous people of God suffering in silence at the hands of the wicked, without other hope than patiently to wait for the interposition of Jehovah (Ps. xiii., xxv., xxxvii., xxxviii., etc.). Nothing can be further removed than this from any possible situation in the life of the David of the books of Samuel." On the contrary, if any one will carefully read what the books of Samuel say concerning David and his relations with Saul, up to a point of time when David had become a fugitive, but before the time of his defection to the Philistines, he will see that the Twelfth psalm accurately fits a situation in the life of David. If any one will get distinctly into mind the situation of David in the period after his domestic troubles began, say from the time of the murder of Amnon by Absalom to the close of David's life, and will observe the extent to which David had brought these troubles upon himself, by practising polygamy, by the sin with Uriah's wife, and in other ways, he will see that just such a situation as this is the situation contemplated in such psalms as the Twenty-fifth and Thirty-eighth. If he will think of David in these later years, repentant, but bound fast to such men as Joab, Absalom, Ahithophel, by bonds that were partly creditable, but partly discreditable, he will find a situation that fits the Thirty-seventh psalm, as it also fits the shorter psalm found in 2 Sam. xxiii. 1-7.

"Even the bare names of the old history were no longer correctly known when Abimelech (the Philistine king in the stories of Abraham and Isaac) could be substituted in the title of Ps. xxxiv. for Achish, king of Gath." But if this argument proves anything, it proves that this title has not yet been written, and never will be; for the time has not yet come when the name of Achish is "no longer correctly known." Whatever explanation may be given for the variation of names here (variant names are too common in the Old Testament to require much explanation), there is nothing in it that has the slightest weight to prove either that the title was written after the name of Achish was forgotten, or that the title is unhistorical.

"Ps. xx., xxi. are not spoken by a king, but addressed to a king by his people." If this were true, it would prove nothing against the Davidic authorship of these psalms; why should not this poet, like other lyric poets, sometimes write from the point of view of others, especially when he writes a song for others to repeat and sing? But Ps. xxi. bears every mark of having been written by the king in question, as well as to the king.

"The titles which ascribe four of the pilgrimage songs to David and one to Solomon are lacking in the true LXX., and inconsistent with the contents of the psalms." Considering the extent to which the copies of the Septuagint differ both among themselves and with the Hebrew, no one should regard the omission of these titles by the Septuagint as very significant. As to whether the contents of these psalms are incon-

sistent with their coming from David and Solomon, that can best be decided by any one for himself, by reading the psalms in question. They are Ps. cxxii., cxxiv., cxxxi., cxxxiii., and cxxvii. Any ordinary reader, reading with this question in mind, will probably decide that the sentiments of these psalms are such as would come with peculiar appropriateness from David and from Solomon.

"The notes struck in the Lamentations and in Isaiah xl.-lxvi. meet our ears again in not a few psalms of book i." The psalms cited in proof of this are xxii., xxv., xxxiv., xxxv., xxxviii., xli., and xxxi., "with many points of resemblance to Jeremiah." "Other psalms of the collection treat the problems of individual religion in the line of thought first opened by Jeremiah. Such a psalm is xxxix. and above all Ps. xvi." But the phenomena referred to in these statements are best explained by the view that these psalms were already ancient in the times of the prophetic authors mentioned, and were familiarly known to them as the ancient sacred songs of the nation. It follows that "the line of thought" alluded to was not "first opened by Jeremiah," but was found by Jeremiah in the Davidic psalms, and used accordingly.

If any reader of the preceding paragraphs takes the trouble to verify them by carefully reading the passages of Scripture referred to, he will probably find himself wondering how any man could possibly be led to make such statements as those that have been quoted; perhaps the fact that the misstatements in the quoted passages are so very palpable may lead him to question whether the present treatment of them is not one-sided and unfair. But to explain this puzzling fact, he need only plant himself at the point of view from which the quoted statements are made. If it were true that the Pentateuchal legislation came into existence long after the times of David, and the ceremonial parts of it mostly after the exile, then it would be true that all the psalms that mention this legislation are of correspondingly late date. Again, those who hold, as a fundamental part of their theory of the origin of the Hexateuch, that literary and humane culture in Israel practically began several generations later than David, are obliged so to understand the history of the times of David that it will be consistent with their view. It is a part of their work to analyze, emend, and correct the books of Samuel, to submit these books to what they call a process of sifting, so as to make the books conform to the truth, as the truth seems to them. The statements quoted above in regard to the character of David and his times are based, not on the books of Samuel as found in the texts, but on what these critics understand to be the credible portions of the books of Samuel, interpreted according to a certain scheme for the historical development of Israel. Facts like this at once account for the statements that have been quoted, and corroborate the reasons that have been given for condemning them.

The article in the *ENCYCLOPÆDIA BRITANNICA* regards Ps. li. as a psalm of the exile, purely on the ground of its mentioning, in the last two verses, the offering of sacrifices and the building of the walls of Jerusalem; but according to the historical books of the Bible these marks fit David's time. From the mention of Zebulon and Naphtali along with Benjamin and Judah, in Ps. lxxviii. 27, it infers that this psalm must have been written later than Nehemiah's time; but, according to the historical books, this mark accurately fits the time of David. It is useless to multiply examples. Evidently, the reasons alleged to discredit the titles of the psalms have no great weight, and the titles remain, as a whole, historically credible.

The Testimony of the New Testament.—In many different passages the New Testament books connect the name of David with the following psalms that have this name in their titles: Ps. xvi., cxxii., lxxix., cix., cx. (see Concordance), and also with Ps. ii., cxxxiii., and xcv., which are anonymous in the Psalter. The

last instance appears in Heb. iv. 7: "Saying in David, after so long a time . . . To-day if ye shall hear his voice, etc." In this case it would not be difficult to understand the writer as merely citing the book that commonly went by the name of David; not necessarily as testifying that David wrote the particular psalm here cited. But in all the other instances the personal attribution of the psalm quoted to David is, verbally, at least, and, to all appearance, really, as explicit as possible. See, for example, Acts ii. 25, 29, 34, or iv. 25, 26. If this testimony is to be believed (and there is no reason for disputing it, even apart from all supernatural claims made for it), it confirms the titles to five of the psalms, thus incidentally confirms the testimony of the titles in general, adds Ps. ii. and less distinctly Ps. cxxxii. (Acts vii. 46) to the list of those written by David, and strongly points out David as pre-eminently the great writer of psalms.

The Testimony of the Books of Chronicles, Ezra, and Nehemiah.—These books testify to the personal existence, in David's time, of the singers Asaph, Heman, and Jeduthun, whose names appear in the titles of certain psalms, and that their function as singers was handed down from the times of David, 1 Chron. vi. 33, 39; xv. 19; xxv.; 2 Chron. v. 12; xx. 14; xxix. 13, 30; xxxv. 15; Ezra ii. 41; iii. 10; Neh. vii. 44; xi. 17, 22; xii. 35, 46, and many other passages. In these same passages they testify to David's personal interest in sacred song. They testify to the public use in Israel of a group of songs giving thanks to Jehovah because his loving-kindness is forever (such songs as Ps. cvi., cvii., cxviii., cxxxvi., all anonymous) from the time when David brought up the ark to Jerusalem, and onward, 1 Chron. xvi. 34, 41; 2 Chron. v. 13; vii. 3, 6; xx. 21; Ezra iii. 11, etc. In 1 Chron. xvi. 7-36 it seems to be asserted that Ps. cv., xevi., and cvi. were placed by David in the hands of his singers at the time when he brought the ark to Jerusalem; and in 2 Chron. vi. 41, 42, it seems to be affirmed that Ps. cxxxii. was used at the dedication of the temple. These four psalms are anonymous in the Hebrew; the Septuagint calls Ps. xevi. Davidic, and connects it in some way with the building of the "house after the captivity;" as we have seen, Ps. cxxxii. is alluded to in Acts vii. 46, as containing sentiments of David.

This evidence is at some points lacking in explicitness, but there can be no doubt that it recognizes David as the great original writer of psalms, that it associates Asaph and the others with David, or that it attributes to them a group of psalms, mostly of liturgical character, which can be quite plausibly identified with several of our present psalms that have not David's name in their titles.

But it is alleged that the books containing this evidence are of late date, and take an uncritical view of the history of David's time, attributing to it the characteristics that belonged only to the second temple and its worship. That the books are relatively of late date is true, though there is no proof that they are later than Nehemiah: whether they are untrustworthy is a different question. So far as their testimony to the Psalms is concerned, it fits in well with what other evidence there is in the case. Many conservative scholars, indeed, admit that Ps. cvi., among those testified to in Chronicles, cannot be of David's time, because of its closing lines:

"He made them also to be pitied,
Of all those that carried them captives.
Save us, O Lord, our God,
And gather us from among the nations."

But if it were sure that these words refer to the Babylonian exile, it would be easy to regard them as an addition: and it is not at all sure that they have any such reference. At the time when David brought up the ark, a few years after the close of a series of Philistine invasions that had lasted for a generation, it is

certain that there were yet Israelitish fugitives, both slaves and sojourners, scattered in the neighboring countries; on that joyful occasion, why should not the minds of the people turn to these, their suffering brethren, just as naturally as if they had lived several hundred years later?

Other Testimony.—The testimony of the psalm-titles, the New Testament, and the Books of Chronicles is confirmed by many incidental notices in the earlier books. Psalm cxxxvii. distinctly presupposes that Judah, before the time of the exile, had well-known songs of Zion. The songs giving thanks to Jehovah because his loving-kindness is eternal are alluded to as something familiarly known in Isa. liv. 8; Jer. xxxiii. 11. In the times of Amos the name of David was celebrated among lovers of music and song, Amos vi. 5. In 2 Sam. xxii. the Eighteenth psalm is attributed to David, and the habit of lyrical production is ascribed to him in 2 Sam. xxiii. 1-7; i. 17, seq.; iii. 33, 34. According to 1 Sam. xvi. 14-23, etc., David's first entrance into public life was due to his celebrity as a skilled musician. Facts like these have no small value as corroborative evidence.

Considerable additional testimony, dating earlier than the Christian era, might be drawn from the Septuagint translation, from the additional titles to the psalms found in the Septuagint, and from the Apocrypha and the other Jewish-Greek literature, and it would all be to the same effect with that already cited. As contradicting the idea that some of the psalms are later than the Persian period, it may be noticed that the Septuagint titles often contain the names of Jeremiah, Haggai, and Zechariah, but no later names. If the Septuagint translation of the psalms had not been made till nearly 130 B. C., and a good many of the psalms had then only just been written, the signs of this in the Septuagint would certainly be very different from the phenomena actually presented there.

Internal Evidence.—A full consideration would require us now to take up each particular psalm, comparing its internal phenomena with the evidence at which we have been looking, and reaching a separate conclusion in the case of each psalm by itself. This we cannot do, but there are certain general facts of internal evidence that are worth looking at.

Among the psalms that are attributed to the times of David, either by their titles or by the notices in the history, are several that recapitulate the history of Israel—Ps. lxxvii., lxxviii., assigned to Asaph, cv., cvi., called Davidic in 1 Chron. xvi., cxxxvi., with the refrain "his loving-kindness is forever." In each case the psalm recapitulates the history as now found in the Pentateuch, Joshua, Judges, and Samuel, stopping with the times of David or a little earlier. The most natural explanation of this fact certainly is that the writers lived in the times of David, and brought the history up to their own times; in proof of this compare the similar repetitions in Neh. ix. or Ecclus. xlv. -1. "The view of Israel's past history taken in Ps. lxxviii., where the final rejection of the house of Joseph is co-ordinated with the fall of Shiloh and the rise of Zion and the Davidic kingdom, indicates a standpoint very near to that of Chronicles." But Ps. lxxviii. 60-64 is evidently a description of the capture of the ark and the killing of Hophni and Phinehas in Eli's time. The refusing of Joseph in the following verses is not the ultimate casting off of Northern Israel, but the transfer of the sanctuary from Shiloh to Jerusalem, from the territory of Ephraim to that of Judah. It is true that the passage "indicates a standpoint very near to that of Chronicles," in the sense that the psalm takes the same view of the history that is taken in the Books of Chronicles; but that is to be accounted for by the fact that both look at the history correctly. It has no weight at all to show that this psalm is of even date with the Books of Chronicles.

This reasoning is not necessarily vitiated by the fact

that several of the Asaph psalms, notably Ps. lxxiv., lxxix., lxxx., and probably lxxxiii., are evidently later than the times of David. The account given in the Bible seems to be that a guild bearing Asaph's name existed from the time of David's Asaph onward. From this we might naturally expect that the psalms bearing this name would be of various dates.

In the *ENCYCLOPEDIA BRITANNICA* the psalms just mentioned, together with Ps. xli., xlix., lxxiii., and lxxxvii., are referred to the time of an alleged revolution in Judæa, in the reign of Artaxerxes Ochus, of Persia, about 350 B. C. But the very existence of this revolution is at best a slimly supported conjecture, too uncertain to be justly described as "an historical situation which can be very definitely realized." It is said of these psalms, "They are post-exile in their whole tone, and belong to a time when prophecy had ceased and the synagogue worship was fully established (lxxiv. 8, 9)." But the statement—

"We see not our signs:
There is no more any prophet,"

does not necessarily imply that the gift of prophecy had ceased when the words were written, but only that there were no prophets just then available (cf. 1 Sam. xxviii. 6, 15). Further, the statement, "They have burned up all the synagogues of God in the land," does not justify the assertion that the synagogue worship was then fully established. There is no proof and no probability that the word *moed* here means "synagogue;" it may possibly mean places of religious service of some sort, though this would be a singular meaning for it; it is ordinarily used to describe the great annual festivals, and the Septuagint and Vulgate translators understood that it was so used here. This meaning makes good sense, for, in the thought of the Psalmist, the burning of the temple was the burning up of all the religious solemnities that centred in the temple. It is an error to say that Ps. lxxiv. is referred to in 1 Mac. vii. 16. The reference there is to Ps. lxxix., and this psalm is cited in Jer. x. 25, and apparently alluded to in several places in Jeremiah. The suggestion that Ps. lxxxiii. represents Ashur as "the satrap of Syria" is quite a feat of exegetical imagination. "That it is not of the Assyrian age is obvious from the mention of Arab tribes" is an assertion which should be compared with the fact that all the tribes mentioned in the psalm are elsewhere in the Bible said to have been in relation with Israel in the times of Saul or earlier. In fine each of these psalms can be assigned to some date earlier than the death of Jeremiah, where it will fit some known group of historical facts much more closely than they fit the situation that has been conjecturally created for them in the time of Artaxerxes Ochus.

The Collection of the Psalms.—Our present collection was formed in part from several earlier collections. So much is evident without accepting all the statements of the *ENCYCLOPEDIA BRITANNICA* on this subject, or taking space to discuss them. The statement that in "Jewish tradition" David "was held to have completed and arranged the whole book" is unfair to all the older and better forms of the Jewish tradition. Fairly interpreted, these simply attribute to David that pre-eminence in psalm-writing which justifies the calling of the collection by his name. There is no reason for holding that the very ancient collection of "The Prayers of David," the subscription of which now appears at the close of Ps. lxxii., was intended exclusively or mainly for liturgical use. So far as appears its characteristics were those of a book of lyric and devotional poems, rather than those of a public hymn-book. The testimony we have cited from Chronicles favors the idea that there was in the hands of the temple singers from the time of David a collection for liturgical use, different from the collection known as the Prayers of David, and including the psalms that

have the refrain, "for his loving-kindness is forever."

The reasons for assigning any part of the work of collecting the psalms to an excessively late date are disproved by the same considerations that disprove the excessively late alleged dates of the psalms themselves. Assertions to the contrary notwithstanding, the doxology at the close of Ps. evi. is naturally to be regarded, like those at the close of Ps. xli., lxxii., and lxxxix., as belonging to the book closing with the psalm, rather than to the psalm itself. This being the case, the fact that 1 Chron. xvi. quotes Ps. evi., with its doxology, may be taken as evidence (not, perhaps, as entirely decisive evidence) that the first four books of the psalms had been collected before that part of Chronicles was written. In any case the five books of psalms were complete before the completing of the Old Testament itself; that is, within the probable time of the life of Nehemiah. See *BIBLE and CANON* in this work, Vol. I., pp. 503, 504, and 708, *seq.*

Literature.—*The Origin and Growth of the Psalms*, by Prof. T. C. Murray, of the Johns-Hopkins University (1880), is a monograph worth reading. The commentaries on the Psalms in the Schaff-Lange series, or those of Delitzsch, are thoroughly good. Such works as Barnes' *Notes* or Spurgeon's *Treasury of the House of David* are rich in practical thought and devotional feeling, however lacking they may be in critical thoroughness. The purpose of *The Psalter a Witness to the Divine Origin of the Bible*, by T. W. Chambers (N. Y., 1876), is indicated by its title. In the successive numbers of the *Journal of the Society of Biblical Literature and Exegesis* are articles by Professor C. H. Toy, advocating an extreme late date for the several groups of psalms. Recent periodical literature abounds in articles on the Psalms. Quite notable is the article of Prof. Smend in the *Zeitschrift für A. T. Wissenschaft*, 1888, on the use of the pronoun of the first person in the psalms. (W. J. B.)

PTOMAINES. See SANITARY SCIENCE.

PUBLIC HEALTH. See SANITARY SCIENCE.

PUBLIC LANDS. The public domain of the United States acquired by cession from the several States and by treaty from France, Spain, Mexico, Texas, and Russia, amounts to 2,894,235.91 square miles, or about 1,852,310,000 acres, and its cost was, in round numbers, \$322,000,000. The first sales of these lands were made in blocks of townships and of 8 sections, but soon in tracts of 640 and 160 acres, and later of 120, 80, and 40 acres. What is known as a township is 6 miles square and contains 36 sections, each section being one mile square, and containing 640 acres of land. A quarter section is $\frac{1}{4}$ mile square, 160 acres. This system of surveys originated with Judge Oliver Phelps (*q. v.*) in 1788. The following is a diagram of a township, with sections numbered according to government surveys:

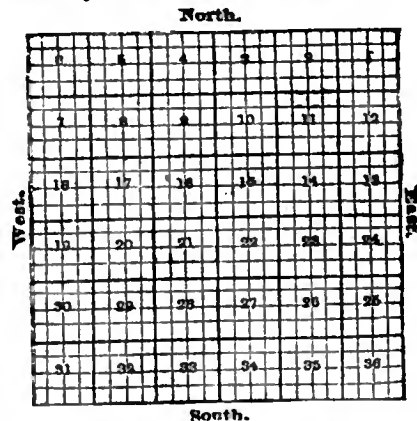

The public lands of the United States which are still undisposed of and open to settlement lie in 19 States and 10 Territories. The following statement shows the number of thousands of square miles sur-

veyed in each of the States and Territories: Alabama, 51; Arkansas, 52; California, 158; Colorado, 105; Florida, 59; Illinois, 55; Indiana, 34; Iowa, 55; Kansas, 81; Louisiana, 45; Michigan, 56; Minnesota, 84; Mississippi, 47; Missouri, 65; Nebraska, 74; Nevada, 112; Ohio, 40; Oregon, 95; Wisconsin, 54; Alaska, 577; Arizona, 114; Dakota, 151; Idaho, 86; Indian Territory, 63; Montana, 144; New Mexico, 121; Utah, 84; Washington Territory, 70; Wyoming, 98; Land strip, 6; total of 2,837,000 square miles—or 1,815,504.147 acres. In each case, except Ohio, Indiana, Illinois, Indian Territory, and Alaska, land offices are established, in charge of an officer known as register of the land office, where the records of all surveyed lands are kept, and all applications concerning lands in each district are filed and inquiries answered. The public lands are divided into 2 great classes. The one class has \$1.25 an acre designated as the minimum price and the other \$2.50 an acre, the latter being the alternate sections, reserved by the United States in land grants to railroads, etc. Titles to these lands may be acquired by private entry or location under the Homestead, Pre-emption, and Timber-culture laws; or, as to some classes, by purchase for cash. In the case of lands which may be purchased at private sale, or such as have not been reserved under any law, such tracts are sold on application to the land register, who issues a certificate of purchase, the receiver giving a receipt for the money paid, subject to the issue of a patent, or complete title, if the proceedings are found regular, by the Commissioner of the General Land Office at Washington.

The following list comprises the U. S. land offices:

- Alabama—Huntsville, Montgomery.
- Arkansas—Little Rock, Camden, Harrison, Dardanelle.
- Arizona—Prescott, Tucson.
- California—San Francisco, Marysville, Humboldt, Stockton, Visalia, Sacramento, Los Angeles, Shasta, Susanville, Bodie.
- Colorado—Denver City, Leadville, Central City, Pueblo, Del Norte, Lake City, Durango, Gunnison.
- Dakota—Mitchell, Watertown, Fargo, Yankton, Bismarck, Deadwood, Grand Forks, Aberdeen, Huron, Greelburg.
- Florida—Gainesville.
- Idaho—Boisé City, Lewiston, Oxford, Hailey.
- Iowa—Des Moines.
- Kansas—Topeka, Salina, Independence, Wichita, Kirwin, Concordia, Larned, Wa Keeney, Oberlin, Garden City.
- Louisiana—New Orleans, Natchitoches.
- Michigan—Detroit, East Saginaw, Reed City, Marquette.
- Minnesota—Taylor's Falls, St. Cloud, Duluth, Ferns Falls, Worthington, Crookston, Benson, Tracy, Redwood Falls.
- Mississippi—Jackson.
- Missouri—Booneville, Ironton, Springfield.
- Montana—Helena, Bozeman, Miles City.
- Nebraska—Beatrice, Lincoln, Niobrara, Grand Island, North Platte, Bloomington, Neligh, Valentine, McCook.
- Nevada—Carson City, Eureka.
- New Mexico—Santa Fé, Las Cruces.
- Oregon—Oregon City, Roseburg, Le Grand, Lakeview, The Dalles.
- Utah—Salt Lake City.
- Washington—Olympia, Vancouver, Wallawalla, Yakima, Spokane Falls.
- Wisconsin—Menasha, Falls of St. Croix, Wausau, La Crosse, Bayfield, Eau Claire.
- Wyoming—Cheyenne, Evanston.

The earliest form of grants of public lands was those to canals, beginning in 1824 and ending in 1866. The total was 4,424,000 acres, divided as follows: Illinois (Illinois River and Lake Michigan), 291,000; Indiana (Wabash and Erie), 1,457,000; Michigan (St.

Mary's Ship Canal, Portage, Superior, La Belle), 1,250,000; Ohio (Miami and Dayton, and General), 1,100,000; Wisconsin (Milwaukee and Rock River and Breakwater), 325,000. The next kind of grants was for river improvements, from 1828 to 1846; and the total was 1,406,000 acres. This was divided as follows: Alabama (Tennessee, Coosa, Cahawba, and Black Warrior), 400,000; Iowa (Des Moines), 322,000; Wisconsin (Fox and Wisconsin), 684,000.

The Pre-emption Act of 1841 was a progressive step, giving a preference to actual settlers, also permitting them to pay for their lands with cash or warrants. According to this act heads of families, widows, or single persons (male or female), over the age of 21 years, who are citizens of the United States, or who have declared their intention to become such, under the naturalization laws, may enter upon any "offered" or "unoffered" lands, belonging to the United States, or any unsurveyed lands to which the Indian title has been extinguished, outside of the limits of any land grant, and purchase not exceeding 160 acres under the pre-emption laws. If the tract is "offered" land, the settler must file his "declaratory statement" in the U. S. District Land Office within 30 days after making settlement; and within one year from the date of settlement he must make proof of actual residence on and cultivation of the land, and thereupon purchase the same at \$1.25 per acre, if outside of the limits of a railroad land-grant, and at \$2.50 per acre if within railroad land-grant limits. If the tract is "unoffered" land, the settler must file his "declaratory statement" within 3 months after the approved plat of the township is received at the U. S. District Land Office, and final proof and payment must be made within 30 months after the expiration of the said 3 months. A pre-emptor may submit proofs of continuous residence at any time after 6 months from the date of settlement and obtain title to his land. The settler in possession of a valid pre-emption claim may, at any time, convert his pre-emption claim into a homestead. No person who abandons his residence upon land of his own (not a town lot) to reside upon public lands in the same State or Territory, or who owns 320 acres of land in any State or Territory, is entitled to the benefit of the pre-emption laws. The Pre-emption Act is now virtually embodied in the 8th section of the Homestead Law to be described below. It is urged that it should be repealed because it is said not to operate uniformly since it does not apply to lands in the Southern States. A very peculiar case arose in regard to actual settlers in what was known as the Territory of Oregon 40 years ago. At that time the territory north of California, indefinitely, was claimed by both England and the United States. In 1846 a treaty designated the parallel 49° N. lat. the boundary between British Columbia and the United States, at which time Oregon contained about 10,000 people. By 1850 the Territory had been organized under the United States, and 3000 more immigrants had arrived. In order to make good titles to land taken up when the sovereignty of the region was doubtful, and also to encourage further immigration, Congress passed what is called the "Donation Law." This perfected titles originating under the previous provisional government, and gave to every actual new settler 320 acres of public land; or, if he were married, it gave him and his wife 640 acres. This law, during its brief existence, aided the settlement of the country so rapidly that the census of only a decade later showed over 50,000 inhabitants.

By far the most important law enacted by the United States was that of 1865, known as the Homestead Act. Under its provisions any person who is the head of a family, or who has arrived at the age of 21 years, and is a citizen of the United States, or has filed his declaration of intention to become such, is entitled to enter one-quarter section, or less quantity, of unappropriated public land. The applicant must make affidavit that he is entitled to the privileges of

the Homestead Act, and that the entry is made for his exclusive use and benefit, and for actual settlement and cultivation, and must pay the legal fee and that part of the commissions required as follows: Fee for 160 acres, \$10; commission, \$1 to \$12; fee for 80 acres, \$5; commission, \$2 to \$6; within 6 months from the date of entry the settler must take up his residence upon the land, and reside thereupon and cultivate the same for 5 years continuously. At the expiration of this period, or within 2 years thereafter, proof of residence and cultivation must be established by four witnesses. The proof of settlement with the certificate of the Register of the Land Office is forwarded to the General Land Office at Washington, from which patent is issued. Final proof cannot be made until the expiration of 5 years from date of entry, and must be made within 7 years. The government recognizes no sale of a homestead claim. A homestead settler may at any time purchase the land under the pre-emption laws if desired, upon making proof of settlement and cultivation for a period of not less than 6 months from the date of entry to the time of purchase. The law allows only one homestead privilege to any one person. A special act covers soldiers' homesteads. Every person who served not less than 90 days in the army or navy of the United States during the War of the Rebellion, and who was honorably discharged and has remained loyal to the government, may enter a homestead, and the time of his service shall be deducted from the period of 5 years, but he or his widow, as the case may be, must reside upon and cultivate his homestead at least one year before final proof can be made, whatever may have been the period of his service. The widow of a soldier, or, if she be dead, or is married again, the minor heirs (if any) may, through their guardian, make a homestead entry, and if the soldier died in the service, the whole term of his enlistment will be deducted from the time otherwise required to perfect the title. Neither the guardian nor the minor children are required to reside on the land, but the land must be cultivated and improved for the period of time during which the father would have been required to reside on the tract. A soldier or sailor as described above may file a homestead declaratory statement for 160 acres of land through an agent, after which he has 6 months within which to make entry of the land and commence his settlement and improvement. This latter entry must be made in person.

It has been proposed that the various homestead acts should be consolidated and that a new law, applicable to all public lands not mineral or timber, should make the entry for lands 160 acres; that a homestead entry should not be considered as consummated until a patent issues; and that the law requiring settlers to advertise their intention to pay for their lands should be abolished. Of course the government expects no revenue from the Homestead Act—the fees and commissions paying only for the cost of survey and the sale. But there is a gain to the nation of more than money value in filing the lands with settlers. The number of acres entered under the Homestead Act for the past 10 years were as follows:

Year.	Acres.	Year.	Acres.
1878.....	4,500,000	1883.....	8,250,000
1879.....	5,250,000	1884.....	7,750,000
1880.....	6,000,000	1885.....	7,500,000
1881.....	5,000,000	1886.....	9,000,000
1882.....	6,350,000	1887.....	7,500,000

There has been a grave abuse of both the pre-emption and the homestead laws. In 1882 and 1881, 7,200 acres of the public lands in Eastern New Mexico were taken up under the homestead and pre-emption laws by one individual for grazing purposes, by entries made in the names of fictitious persons. In the Homestead entries, which comprise the greater por-

tion of the cases, pre-emption declaratory statements were filed in the names of the supposititious claimants, alleging a prior residence of more than 5 years required under the homestead laws. These filings were immediately transmuted to homestead entries and alleged proofs at once made, not more than a month or two elapsing from the date the first papers were filed until the final entries were placed on record. In the proofs the alleged residence of the parties was made to relate back and cover the period from 1876 or 1877 to 1882 or 1883. Mexican names were used to represent claimants, and the papers showed on their face that they were all prepared by one individual, the signatures of alleged claimants and witnesses bearing unmistakable evidence that they were written by the same individual and one other person. The lands were conveyed immediately after entry, and the transferee conveyed them to a cattle company. Reliable persons who had lived near the lands from 5 to 15 years, and were well acquainted in the vicinity, testified that they had never seen or heard of any one of the alleged claimants, and that no such persons ever lived on the lands. It is estimated that fully 90 per cent. of all the entries made under the two acts in the Territory of New Mexico have been fraudulent. Much of the abuse comes from large cattle-owners who fenced thousands of acres without the slightest claim; or who made claim without any fencing whatever. The consequence has been that there has been developed a system of land-holdings on a scale not known in any other part of the world. In many instances the holders are aliens who have no interest whatever in supporting U. S. laws or institutions. Some of these individuals and corporations own millions of acres; and many of them hold areas of several hundred thousand acres.

In this connection the State laws in regard to alien ownership may be noted. In 1883 land-ownership was made the subject of special investigations and it was found that citizens and aliens are on the same footing in Alabama, Arkansas, California, Colorado, Dakota, Florida, Georgia, Illinois, Indiana, Iowa, Kansas, Louisiana, Maine, Maryland, Missouri, Massachusetts, Michigan, Minnesota, Mississippi, Nebraska, Nevada, New Hampshire, New Jersey, New Mexico, North Carolina, Ohio, Oregon, Pennsylvania, Rhode Island, South Carolina, Tennessee, Texas, Utah, Vermont, Virginia, West Virginia, Washington Territory, and Wisconsin. California and Utah require simply a non-resident alien to whom an inheritance falls to claim it within 5 years. This is merely a reasonable statute of limitation. Nevada prohibits a subject of China from owning real estate. Pennsylvania limits the right of purchase in an alien to 5000 acres, but he may hold without limit real estate by devise or descent. This is the only State in the Union that limits the amount of land purchasable by law. In Vermont it was stated in the case of *The State vs. Boston, Concord, and Montreal R. R. Co.*, that while no laws prohibit aliens enjoying real estate, and while the power of escheat may still exist, *strictissimi juris*, yet it has always remained dormant, notwithstanding the frequent occasions for its legitimate exercise. In other words, the common law, although unreppealed, is a dead letter in practice. The Indiana statute of 1881 provides that any non-resident alien may acquire by inheritance real estate as though he were a citizen; but the time during which he may hold, sell, alienate, and convey expires in 8 years after final settlement of the decedent's estate from which it was derived. A resident alien is in all respects in the same position as a citizen, and it may generally be remarked that in States in which restrictive laws are in force the resident has superior rights to the non-resident alien. In the under-mentioned States and Territories the following is the state of the law: Connecticut: Aliens residing in the United States and natives of France can hold and transmit land. Other

aliens are restricted to lands for mining and quarrying only. No doubt exists that a treaty negotiated with a foreign power by the President can abrogate restrictive State land laws in regard to aliens, and this curious exception in favor of the French was probably incorporated in the State laws of Connecticut in deference to the U. S. treaty with France during the Revolutionary war. There are two early Anglo-American treaties on the same subject. Delaware and Kentucky draw the line at resident aliens who have declared their intention to become citizens. New York, which has always been the most progressive in law reform, strangely holds to the doubtful blessing of the common law, although many slight modifications have been made by statute. A declaration to become a citizen is still necessary to make a legal devise of lands. Up to 1881 the Territories of Arizona, Idaho, and Montana seem to have enacted no laws upon the subject, but the practice is undoubtedly in conformity with all the Western States in granting the fullest power to the alien. A bill was introduced in the Senate of the United States, in 1884, limiting foreign holdings to 30 square miles of land. This bill was not passed; but it is evident that some restriction of the sort is needed. There can be no doubt that settlement has been retarded in the regions affected by the course of the land-thieves. The only check to the monopoly of the cattle-men in some of the Territories has been the spread of sheep-farming, which prevents range-feeding for cattle. The use of the wire fence, by these corporations, noted above, was found to be so reckless that, in August, 1885, Pres. Cleveland issued the following proclamation: "I do hereby order and direct that any and every unlawful enclosure of the public lands, maintained by any person, association, or corporation, be immediately removed, and I do hereby forbid any person, association, or corporation from preventing or obstructing by means of such enclosures, or by force, threats, or intimidation, any person entitled thereto from peaceably entering upon and establishing a settlement or residence on any part of such public land which is subject to entry and settlement under the laws of the United States; and I command and require each and every officer of the United States upon whom the duty is legally devolved to cause this order to be obeyed and all the provisions of the act of Congress herein mentioned to be faithfully enforced."

The Timber Culture Act of 1878 provides that public lands, naturally devoid of timber, may be acquired by planting trees thereon and keeping the same in a healthy, growing condition for 8 years. Not more than 160 acres in any one section can be entered, and no person can enter more than 160 acres or make more than one entry under these laws. An applicant must be the head of a family, or 21 years of age, and a citizen of the United States, or he must have filed his declaration of intention to become a citizen, as required by the naturalization laws. The Land Office fee for an entry of more than 80 acres is \$14; and for 80 acres or less, \$9; and \$4 when final proof is made. Land to be entered must be entirely devoid of timber. In order to acquire 160 acres of land, 10 acres must be cultivated and planted with trees; 5 acres must be cultivated and planted with trees to acquire any legal subdivision of 80 acres; and 2½ acres to acquire any legal subdivision of 40 acres or less. The person making entry of 160 acres is required to break or plow 5 acres during the first year, and 5 acres during the second year. The 5 acres broken or plowed during the first year must be cultivated to crop, or otherwise, during the second year, and be planted to timber during the third year. The 5 acres broken or plowed during the second year must be cultivated the third year, and planted to timber during the fourth year. For entries of less than 160 acres, a proportionate number of acres must be plowed, planted, cultivated, and planted to trees. These trees must be cultivated and protected

for not less than 8 years; and at the expiration of that period, or within five years thereafter, proof must be made by the claimant and two creditable witnesses, showing that there were at the time of making such proof at least 675 living, thrifty trees on each of the 10 acres required to be planted; also that not less than 2700 trees were planted on each of the 10 acres. Fruit-trees are not considered timber within the meaning of this act. Title cannot be obtained prior to the expiration of 8 years, and final proof must be made within 5 years after the expiration of the said 8 years. While the object of the act was a good one, the act itself has been abused quite as much as the Homestead and Pre-emption Acts. About 10,000,000 acres of agricultural lands have been located under it as a disguise; and it is urged that the act should be repealed, on the ground that the timber is actually necessary for the development of the country, since both mining and settlement are impossible without it. A very grave abuse of the timber laws was reported early in 1888, more particularly from California. This report was based upon investigations made during the two previous years. It was shown that the abuses were committed partially by a group of capitalists who coveted the choice redwood forests of Humboldt county. They engaged a group of timber speculators to get possession of the land and transfer it to them. The speculators hired 600 persons to take 160 acres apiece under the Timber Land Act, each swearing that he applied for the land "in good faith to appropriate it to his own exclusive use and benefit," and that he did not intend to transfer the title to any other person. Records of the county show that the timber alone on the land seized by these companies had an estimated value of \$11,000,000. Since the exposure many entries have been held for cancellation, and proceedings have been instituted to set aside patents issued on many such entries.

What are known as the "Swamp Land Grants" were made under the act of 1854 relating to desert lands. This act provided that any person who is a citizen of the United States, or any person of requisite age who may be entitled to become a citizen, and who has filed his declaration to become such, may file his oath with the Register and Receiver of the Land Office in the district in which any desert land is located, that he intends to reclaim, not exceeding one section of said land, by conducting water upon it, within 3 years; and by paying to the receiver the sum of 25 cents per acre for all the land claimed, such person may enter said land under the act. At any time within 3 years a patent can be obtained by making proof that he has reclaimed said land, and paying the additional sum of \$1 per acre. No person can enter more than one tract of land, and not to exceed 640 acres, which shall be in compact form. This act applies to desert land in Dakota, Montana, Idaho, Washington, and Oregon. Desert lands are defined by this act to be all lands, exclusive of mineral and timber lands, which will not, without irrigation, produce some agricultural crop. Even this law has been the cause of great abuse; because many lands have been claimed which were as fertile as any classed under the other acts for settlement. Nearly 100,000 acres were granted under this act during the year ending June 30, 1888; and the aggregate reaches 57,000,000 acres. The greater part of these grants have been made in the State of Florida; Louisiana, Michigan, and Oregon coming next in order. The original grants were made for the purpose of enabling States to construct levees necessary to reclaim swamp and other lands; but it was required that the proceeds of such lands should be applied to the reclamation of the same. The claims of many States were transferred to counties, and the money realized was used in such counties for roads, bridges, and many other purposes not contemplated by the law. Some of the lands have even been disposed of to railroads. Consequently only a small part of the proceeds has really gone to reclaim the lands. Further acts of 1855 and

1857 provided indemnities in such a way that nearly 600,000 acres of good land have been obtained so that certain agents could draw their percentages. A thorough investigation has, however, been prosecuted by the U. S. Land Office. The United States have also granted lands from time to time to the several States for educational purposes. At the present time (1888) there remain of such lands 1,850,000 acres. The good or bad use of such lands depends upon the people of each State respectively.

The most important and far-reaching grants of the United States have been those to railroads. Until 1850 the development of the Western territory proceeded gradually and steadily, by normal and natural methods of growth. Indiana, Michigan, and Illinois had become prosperous and populous States rapidly, it is true, but not by any speculative or adventitious means. As emigration from the East formed here and there upon the Western prairies, and along the water-courses of the great Mississippi Valley, the comforts and conveniences of the Atlantic States soon followed in its train. Where new railways were needed new railways were built, by private capital, in the ordinary way, just as they had been in the East. But, in 1849, the California gold fever quickened the pulse of the nation to an unnatural degree. All at once a State of the Union loomed up in the far West—as far from New York in one direction as Europe was in the opposite direction—and the country awoke to realization of the vastness of its domain and its glorious possibilities in the way of material wealth. Emigration became a national fever. Everybody who could do so went off to Iowa, Minnesota, Kansas, Nebraska, California, Oregon, and the intermediate Territories. The consequence was that there was soon a great population in those parts; but the inhabitants were widely scattered, and there were few large towns between St. Louis and San Francisco. The several laws allowing grants to railroads began in 1850 and ended in 1874. Nearly all the lands were taken by 1866, and their aggregate now (1888) is about 37,000,000 acres. This has been divided among the several States, in round numbers, by the thousand acres, as follows: Illinois, 2600; Mississippi, 1000; Alabama, 3000; Florida, 1760; Louisiana, 1072; Arkansas, 2517; Missouri, 1400; Minnesota, 8000; Kansas, 4638; Iowa, 4708; Michigan, 3229; Wisconsin, 3400. Between 1863 and 1869 a total of nearly 2,000,000 acres was granted for wagon roads, as follows: Wisconsin, 303,000; Michigan, 221,000; Oregon, 1,260,000. The grants for railroads to the several States were applied toward constructing the following railroads: Illinois—Illinois Central; Mississippi—Mobile and Ohio, Vicksburg and Meridian, Gulf and Ship Island; Alabama—Mobile and Ohio, Alabama and Florida, Selma, Rome, and Dalton, Alabama and Tennessee, Coosa and Tennessee, Mobile and Girard, Alabama and Chattanooga, South and North Alabama; Florida—Atlantic, Gulf, and West India Transit, Florida and Alabama, Pensacola and Georgia, Florida, Atlantic, and Gulf Central; Louisiana—North Louisiana and Texas, New Orleans, Opelousas and Great Western (in 1870, act passed forfeiting all lands not lawfully disposed of by the State); Arkansas—St. Louis, Iron Mountain, and Southern, Little Rock and Fort Smith, Memphis and Little Rock, St. Louis and Iron Mountain of 1866 (which was declared forfeited in 1884); Missouri—South-west Branch of the Pacific, Hannibal and St. Joseph, St. Louis, Iron Mountain, and Southern, St. Louis and Iron Mountain (forfeited); Iowa—Burlington and Missouri River, Chicago, Rock Island, and Pacific, Cedar Rapids and Missouri River, Dubuque and Sioux City, Iowa Falls and Sioux City, Des Moines Valley, McGregor and Missouri River, Chicago, Milwaukee, and St. Paul, Sioux City and St. Paul; Michigan—Port Huron and Lake Michigan, Jackson, Lansing, and Saginaw, Grand Rapids and Indiana, Flint and Pere Marquette, Marquette, Houghton, and On-

tonagon, Ontonagon and Brulé River, Bay De Noquet and Marquette, Chicago and North-western; Wisconsin—Chicago, St. Paul, Minneapolis, and Omaha, and formerly West Missouri, and formerly St. Croix and Lake Superior with branch to Bayfield, Wisconsin Railroad Farm Mortgage Land Company, Chicago and North-western, Wisconsin Central; Minnesota—St. Paul, Minneapolis, and Manitoba, St. Paul and Pacific, Brainerd Branch, St. Vincent extension, Minnesota Central, Winona and St. Peter, St. Paul and Sioux City, St. Paul and Duluth, Southern Minnesota and extension, Hastings and Dakota; Kansas—Leavenworth, Lawrence, and Galveston, Missouri, Kansas and Texas, Atchison, Topeka, and Santa Fé, St. Joseph and Denver City, Missouri River, Fort Scott, and Gulf. Corporations—Union Pacific, Central Pacific, Western Pacific, Central Branch Union Pacific, Kansas Division of Union Pacific, Burlington and Missouri River in Nebraska, Sioux City and Pacific, Northern Pacific, Placerville and Sacramento Valley of 1866 (declared forfeited in 1884), Oregon Branch of Central Pacific, Oregon and California, Atlantic and Pacific, Southern Pacific and Branch Line, Stockton and Copperopolis of 1867 (declared forfeited in 1874), Oregon Central of 1870 (declared forfeited, as to parts, in 1885), Texas Pacific of 1871 (declared forfeited in 1886), New Orleans Pacific (formerly New Orleans), Baton Rouge, and Vicksburg of 1871 (declared forfeited in small part and confirmed in large part in 1887). Of the grants to corporations the certified acres were as follows, in thousands: Central Pacific, 963; Central Pacific (successor to Western Pacific), 443; Central Pacific, Oregon Branch, 1362; Union Pacific, 2616; Union Pacific, central branch, 218; Union Pacific, Kansas division, 964; Union Pacific, successor to Denver Pacific, 165; Burlington and Missouri River, in Nebraska, 2373; Sioux City and Pacific, 41; Northern Pacific, 746; Oregon and California, 322; Atlantic and Pacific, 959; Southern Pacific, 1040; Southern Pacific, branch line, 188; New Orleans Pacific, 679; total, 13,085,000 acres.

These land grants had always been given with the condition attached that the roads must be constructed, finished, and put into operation before a certain specified time, failing which the grant would be inoperative. No attention, however, was paid to this part of the matter for many years. Grants were made to one road after another in quick succession, and the time had not yet arrived for inquiry as to how the beneficiaries were fulfilling their side of the contract. Then came the civil war, which concentrated all the care and energy of the nation to the exclusion of all minor matters; and it was not until long after the war that the government bethought itself of the interest it had in these Western roads. The Forty-seventh Congress, which began in 1881, was the first Congress to consider the question of forfeiture. The question arose in this way: Some settlers who had established homesteads in the upper peninsula of Michigan were suddenly confronted by the agents of a railway company who claimed their lands under the provisions of an old land grant, the terms of which had never been complied with by the company. The lands had belonged to the company at one time by the language of the grant, but the road had not been built, and the term of years in which it was ordered to be built had expired. The settlers took the matter to the courts, including the Supreme Court, but the decision was against them. In despair they turned to Congress for relief, and their petition was referred to the House Judiciary Committee. Nothing was done by this Congress; but the Forty-eighth Congress, in 1884, took up the matter and passed a resolution that all railroad land grants which have not been earned by the fulfilment of the conditions specified in the respective acts ought to be declared forfeited and restored to the public domain; and that the whole system of land laws now existing ought to be overhauled, and so changed as to open the

agricultural portions to actual settlers only, and to prevent grabs of public lands of any kind, whether farming, mineral, or forest. The question continued to be agitated with good results. The land department of the Central Pacific Railroad Company decided to sell no land to any person who would not keep and improve it, making a large reduction, however, to such persons. The railroad also proposed to retain control of the land until it had been improved in the manner agreed upon, and reserved the right to prevent a sale to speculators. Congress, on the 3d of March, 1887, passed a law providing that the Secretary of the Interior shall immediately adjust, in accordance with the decisions of the Supreme Court, each of the railroad land grants made by Congress to aid in the construction of railroads, and heretofore unadjusted. In October of the same year the Commissioner of the Land Office decided that an actual settler on restored railroad lands, who holds a deed from the railroad company, can secure title from the government under the pre-emption or homestead laws, provided he has not exhausted his privilege thereunder. The 5th section of the act of March 3, 1887 (24th *Statutes*, 5006), provides that when lands within the limits of railroad grants coterminous with the constructed portions of the lines of roads, which lines have not been conveyed on account of the grants, but were excepted from the operations of the same, and which have been sold by the railroad company to citizens, or to persons who have declared their intentions to become citizens of the United States, such lands at the date of purchase from the railroad company not being in the bona-fide occupation of adverse claimants under the pre-emption or homestead laws of the United States, and where claims and occupations have been voluntarily abandoned, and where such lands are not of the class described as settled upon subsequent to the 1st day of December, 1882, by persons claiming to enter the same under the settlement laws of the United States, then bona-fide purchasers from the railroad company, if qualified as to citizenship, their heirs or assigns, may make payment to the United States for such lands at the ordinary government price for like lands, and receive patents therefor.

As the result of the agitation relating to forfeitures it is now stated that the adjustment of the grant to one wagon-road and 32 railroads has been completed. This adjustment discloses the fact that 7 railroads and one wagon-road have had land certified or patented to them in excess of their respective grants to the amount of 218,590 acres, and suits are recommended, under said act, to vacate such illegal patents or certificates. There are 2000 forfeiture cases pending in the U. S. Land Office, and lands in the indemnity limits of the Northern Pacific, the Atlantic and Pacific, the Southern Pacific, the California and Oregon, and the Oregon and California roads, to the extent of 17,830,000 acres, are affected by these cases. Of the 25,429,866 acres of land covered by selections pending at the close of the fiscal year, 1888, 21,660,486 acres were selected by railroad companies whose roads were not completed in the time required by their respective grants. It has been recommended that there should be forfeiture of all lands coterminous with those parts of the respective roads which were uncompleted at the expiration of the limited time for their construction.

The future of the country depends largely upon the settlers that will occupy the unoccupied public lands. Upon the ownership of these lands by small holders rests the security of the country from internal disturbances. It is stated that in England only 1 person in 20 is an owner of land; in Scotland, 1 in 25; in Ireland, 1 in 79; and that the great majority of landholders in Great Britain own less than one acre each. From past experience it is not likely that any such record as this can ever be made in regard to the public lands of the United States. But it would seem that the laws should be so amended that the same settler

cannot take 130 acres under the Homestead Act; 130 acres under the Pre-emption Act; 640 acres under the Desert Land Act; and 160 acres under the Timber Culture Act—a total of 1060 acres. (F. G. M.)

PUEBLOS, an interesting family of Indians of New Mexico and Arizona, agricultural in their habits, and dwelling in very large, single habitations, sometimes capacious enough to contain a whole tribe. They are also known as Village Indians, village being the English rendering of the Spanish *pueblo*. The remarkable edifices built by these semi-civilized tribes are in some cases constructed of stone laid in mud mortar, but more generally of adobe or sun-dried brick. They cover a considerable area and are several stories high, sometimes 5 or 6. They are in some cases built in the form of a hollow square; in others on the brow of a high bluff or mountain terrace of difficult approach. Defence against enemies seems, indeed, an essential feature in their construction, and the lower story is invariably without doors or windows, the only entrance to the house being attained by ladders leading to the second story. Each story recedes a few feet from the line of that below it, leaving a terrace, which extends round the whole structure, to which this successive decrease in area of the stories gives something of a pyramidal aspect. There are no stairways anywhere in the edifice, all access to higher stories being attained by ladders. In some of these extensive edifices whole communities, numbering from 300 to 700 souls, reside, each family having a single apartment. Should this become overcrowded by increase of the family another apartment is occupied, or if there be none vacant, a new one is built above, thus adding to the height of the building. In each edifice there are reserved one or more large rooms capable of holding several hundred persons. These form the council-chambers of the tribe, and are also used for the tribal dances, of which there are several kinds, apparently connected with religious rites.

There are 19 of these villages in New Mexico, most of which have been occupied for a very long period, their inhabitants obtaining a livelihood by the cultivation of the soil, in which they have considerable skill. Their occupants number over 8000 souls and possess about 900,000 acres of land, but only 100,000 are tillable. On these they raise maize, wheat, vegetables, fruit, and cotton, while they possess considerable herds of horses, cattle, mules, goats, and sheep. The rainless character of the region renders irrigation necessary, and they have a well-devised system of ditches, many of which have been in use for centuries. They are economical in their habits and hard workers, each head of a family having a farm of his own, not well cultivated according to our ideas, yet sufficiently so to provide the necessities of life. As a people they are quiet, honest, and law-abiding, take good care of the farming implements with which the government has provided them, and are making slow but steady progress in education and civilization. In addition to agriculture they possess certain simple industrial arts, spinning and weaving cotton and wool into fabrics for clothing and heavy blankets, while they have some skill in the manufacture of pottery, which they ornament with various designs in color and geometrical figures. Their warlike habits are of a barbarous character, approaching those of the Aztecs. It is said that when an enemy is killed in battle they cut off his scalp, drink his blood, and bathe their faces and garments in it. Then they wet their hands in it, believing it will increase their strength and courage. The scalp of an enemy is placed in the hands of him who first took it, even if he was not present at the killing, and he is afterwards regarded with distinction, as if he had performed some great deed of valor. It can, fortunately, be said that all this refers to their former customs, as they have no opportunity or incitement under present conditions to indulge in hostilities.

In addition to the New Mexican tribes there are a

number of related agricultural tribes in Arizona some of which differ in their building habits from the former, yet are connected with them in other particulars. The Moquis tribes, numbering about 2200 and speaking languages of a different family, erect buildings like those described, these being placed on the summit of high mesas or isolated hills, which rise abruptly from the plain to the height of from 300 to 500 feet, and are so steep as to be almost inaccessible to an enemy. There are seven of these villages in the Arizona agency, only two of which are accessible by a wagon-road. Of these that known as Oribi is much the largest. The houses are all of stone, many of them 3 or 4 stories high, with flat, dirt roofs, cement floors, and small windows and doors. Lumber is such a luxury that it is seldom used even for doors. The furniture is very simple, a sheepskin serving for chair, the floor for table, while a few baskets, blankets, and pieces of pottery constitute the whole of the household goods. Nearly every family has a corn-mill, in which the grain is ground to flour by hand, rubbing with a stone. The Moquis are pastoral and agricultural in their habits. Nearly all have a few sheep, and some have large flocks of sheep, besides horses and barros. They all cultivate the soil, the farms of some being 15 miles or more from the village, their field-crops being wheat and corn, onions, beans, and melons their favorite vegetables, while peaches, apricots, and other fruits are raised. They weave their own belts and blankets and a coarse kind of cloth, and have some skill in the making of pottery.

The Pima Indians of the lower Colorado region are apparently of the same stock and cultivate the ground, but are of a lower grade of civilization. Their dwellings are the ordinary wigwam of the northern Indians, rudely built, with a hole on one side, through which the savage crawls into his home. They have no chimney or other means of ventilation, and are too low to allow him to stand erect, while the smoke is generally thick enough to stifle a white man. These are their winter habitations; in summer they live in the fields under a shelter made of forked sticks, covered with brush and poles to protect them from the sun. There are some 4000 in all of these and the related Mariposa tribes.

The Pueblo Indians have been known for over three centuries, their habits when first known being the same as those displayed now, and many of their habitations the same. They were first visited by Alvar Nuñez during his remarkable journey from Florida to the Pacific between 1529 and 1538; afterwards by De Niza in 1539, and in 1540 by Coronado, who visited and described the villages in much the same language as would now be applied to them. The "City of Cibola," called by others Zuñi, visited by him, is still in existence, and inhabited by one of the most interesting of the Pueblo tribes. Of the earlier history of these Indians nothing is known. They have a few vague traditions, but nothing definite; yet the ruins of old pueblos and the remains of ancient pottery, which are found not only near these ruins but generally over the plains, indicate a high antiquity and a much more numerous population than at present. In the Valley of the Gila, thirty miles above the Pimo villages, are traces of ancient canals, adobe buildings, and pottery of a superior character. The same is the case in other parts of northern Arizona, there being evidences of extensive irrigating works and a large population, while numerous remains are found in New Mexico, some of them more extensive and exhibiting a higher type of art than in the present villages. Mr. Bandler, who examined these ruins and studied the Indian habits under the direction of the American Institute of Archæology, has determined that the area formerly occupied by the Pueblo Indians is bounded on the east by a region 40 miles west of the Pecos River, New Mexico, and extends west to within about 100 miles of the Colorado. Northward it reaches to nearly

the 40th parallel of latitude, while the limit of southward extension is not well indicated. The pueblos vary in degree of skill, and indicate a gradual development from the Indian lodge to the complex edifice. He doubts the assertions sometimes made about a former large population, and thinks that the many buildings indicated by the ruins were occupied successively, and not simultaneously. This seems confirmed by the traditions of the Zuñis and the Pimos.

There are certain reasons to believe that village life was in decadence at the period of the first discovery of these remarkable habitations, and it seems probable that the industrious Pueblo tribes, after developing a primitive agriculture by means of irrigation of the soil of this rainless region, and growing numerous and powerful, were driven south by the hostile tribes of the nomadic Indians of the north, the strange cliff-dwellings of the river cañons of Colorado being defensive points occupied in their gradual retreat. Whether agriculture was original with them, or was derived from the civilized peoples of lower Mexico, cannot well be ascertained. All that can be said is that there seems no linguistic connection with the Aztec or other Mexican nations.

The process of civilizing these Indians has gone on ever since their first discovery. Catholic missions were established among them two centuries ago, and many of them are Roman Catholics to-day, though their Christianity is deeply diluted with paganism, and they still cling to their old beliefs and practices. Among these is the maintenance of the sacred fire and the worship of Montezuma, a deity not to be confounded with the emperor of the Aztecs. The Pueblo Indians were the citizens of Mexico, and came into the United States with the rights thus acquired. They thus maintain a different relation to the government from any other Indians, and hold their lands in fee under government patents. The treaty with Mexico, as interpreted by Chief-Justice Slough in 1857, makes them full citizens of the United States, but they have not as yet been recognized as such either by the Federal or the territorial authorities. The internal administration of the tribes remains in their own hands, and is conducted in accordance with their old customs, each village being controlled by a governor and a council of three elders.

Under American control the Pueblo Indians are making promising and substantial progress in civilization and education, and will undoubtedly become very useful citizens in the near future, being self-sustaining, peaceful, and law-abiding. Large numbers of their children are at school, and compulsory education is practised with good results. Seven day-schools and two boarding-schools are conducted by the Catholic Board of Missions, and four day-schools and one boarding-school by the Presbyterian Board. There is also a government school. The total average attendance is 680. In some of the schools the boys are taught trades, the girls instructed in housework, while in the communities at large wagon-roads have been made, bridges constructed, fields enlarged, irrigation ditches improved and lengthened, better clothing is worn, more fruit-trees planted, and many other indications of growth in ideas and prosperity are shown. This progress is due to the persistent efforts of the reservation agents, who are working vigorously and intelligently for the advancement of their wards. Among the wigwam-dwelling Pimos many have been induced to build adobe houses by presents of wagons and harness, and some of them now possess comfortable and well-constructed farm-houses furnished with tables, chairs, beds, and other civilized appliances, their walls even being adorned with pictures. When we reflect that these Indians have been under the control of the United States for only forty years, this degree of advancement is certainly very encouraging and is full of promise for their future progress in civilization.

(C. M.)

PULASKI, CASIMIR (1747-1779), a Polish Count who fought and fell in the American Revolution, was born in Lithuania, March 4, 1747. His father, Count Joseph Pulaski, organized the confederation of Bar in 1768, and fell in the revolt against King Stanislaus Augustus. Casimir had served in the army of Duke Charles of Courland, and took an active part in the war in defence of Polish liberty against Russian dictation. After the storming of Bar he sought refuge in a monastery, where he was besieged for some weeks and then permitted to depart, on promise to endeavor to effect a reconciliation. This promise he afterwards repudiated as extorted by force. From Moldavia he carried on a restless warfare and in 1771 he even seized the king at Warsaw, but was compelled to release him. Austria and Prussia united with Russia and effected the partition of Poland in 1772. Pulaski's father and two brothers had fallen in the strife; his property was confiscated, and he was sentenced to outlawry and death. After some service in the Turkish army he went to France, where he lived in poverty and obscurity. In 1777 he was brought to the notice of Franklin, who engaged his services in behalf of American independence. Soon after his arrival at Philadelphia, Pulaski's bravery was conspicuous at Brandywine and Germantown, and he was made a brigadier of cavalry. In March, 1778, he joined the main army at Valley Forge and was authorized to organize an independent corps of lancers and light infantry. He visited Bethlehem in the spring, and seems to have had one or more small flags embroidered there by the Moravian Sisters. But the consecration of Pulaski's banner, as described in Longfellow's poem, has no foundation in fact. In six months the Count had raised a legion of 330 men, chiefly in Maryland, and then joined Washington's army in New Jersey. While marching to Little Egg Harbor he was betrayed by a deserter, and surprised by the British, and 40 of his men were killed. In February, 1779, he went to the South to assist in the defence of Charleston. Reaching that city in May, he made a bold assault on the British but was repulsed. Charleston was relieved soon after, and the French Count d'Estaing called the Americans to besiege Savannah. Here an assault was ordered on Oct. 9, and Pulaski, at the head of the cavalry, received a mortal wound. He died on board the brig *Wasp*, Oct. 11, 1779, and was buried at St. Helen's Island. In 1825 Lafayette laid at Savannah the corner-stone of a monument, erected by the people of Georgia. A flag or banner of Pulaski, 20 inches square, is in possession of the Maryland Historical Society at Baltimore. Jared Sparks wrote the *Life of Count Pulaski* (1845) in his *American Biography*.

PULSZKY VON LUBOCZ UND CSELEVA, **FRANZ AUREL**, Hungarian statesman and author, was born at Eperies, Sept. 17, 1814. After completing his education he spent some time in foreign travel, and his *Diary of a Journey in Great Britain* (1837) procured his admission to the Hungarian Academy. He was elected to the Reichstag in 1839. In 1848 he was secretary of the Hungarian Finance Ministry, and later held a similar position in Vienna. Toward the end of that year he took part in the Hungarian revolution and after its failure accompanied Kossuth in his journey through the United States. Pulszky described this country in his *White, Red and Black* (3 vols., 1853). Having in the meantime been condemned to death by a court-martial in Hungary, he took up his residence in England. In 1860 he went to Italy, and took part in Garibaldi's expedition, which ended at Aspromonte, and was for a time a prisoner at Naples. In 1866, when constitutional self-government was granted to Hungary, Pulszky shared in the amnesty and returned to his native land. He was a member of the Reichstag from 1867 to 1875, and attached himself to Deak. In 1869 he was made director of the National Museum, and in 1872 super-

intendent of the public museums and libraries. Since 1884 he has again been a member of the Reichstag. His later works have been his autobiography, *My Life and Times* (4 vols., 1882), and *The Bronze Age in Hungary* (1884).

His wife, **THERESE PULSZKY** (1819-1866), was married in 1845, and after her husband settled in England engaged in literary work. Her principal publications were *Memoirs of a Hungarian Lady* (2 vols., 1850), and *Tales and Traditions of Hungary* (2 vols., 1851).

PUMPELLY, RAPHAEL, geologist, was born at Owego, N. Y., Sept. 8, 1837. He received his scientific training at Paris, Hanover, and Freiberg, Saxony, and returning to the United States in 1860 engaged in mining in Arizona. In 1861 he was employed by the government of Japan in exploring the mineral resources of the island of Yezo and in 1863 by the government of China in surveying the coal-fields of that empire. In 1866 he was made professor of mining engineering in Harvard University. In 1870 he surveyed the copper region of Michigan, and in 1871-73 was State geologist of Missouri, and published *Reports* of his work. When the U. S. Geological Survey was organized, Prof. Pumpelly took charge of the division of economic geology. He was a special agent of the Tenth Census and for its *Report* prepared Vol. XV., on *Mining Industries*. From 1881 to 1884 he was engaged in the Northern transcontinental survey, which he organized. Since 1884 he has been geologist of the archæan division of the national geological survey. Besides *Reports* of his public work and contributions to scientific journals he has published *Geological Researches in China and Japan* (1866), and *Across America and the Andes* (1869).

PUMPKIN, an annual plant of the *Cucurbitaceæ*, or gourd family, genus *Cucurbita*. Plants of this genus bear large yellow flowers with a bell-shaped corolla, 5-cleft, its base adherent to the calyx tube, with 3 long much curved anthers which unite into a small head, and 3 stigmas. The fruit is fleshy with a firm rind. The pumpkin, *C. pepo*, bears a fruit often of enormous dimensions, and is largely cultivated both in Europe and America, the fruit being fed to cattle and used in domestic cookery. The term pumpkin, a corruption of pompon, is very loosely applied in this country. In some sections it is used to include the squashes, members of another species; in others it embraces only the few varieties of the common New England pumpkin. The latter is a vigorous, prostrate plant, running 12 feet or more, with a hairy, almost prickly stem, the fruit being nearly round or elongated, of large size, the outer surface ribbed or furrowed, the internal portion mellow and crossed by pulpy threads. The average size of the fruit is about one foot diameter, though it is often much larger, its color a clear orange-yellow. As ordinarily grown, the seeds are planted in fields of corn or potatoes, and the plant left to take care of itself; yet, even with this neglectful agriculture, it often yields as much as a ton of the fruit per acre without apparent detriment to the yield of corn or potatoes from the same field.

The native country of the pumpkin is disputed, but there is good reason to believe that it is indigenous to America. The common field-pumpkin was much used for food in New England before the introduction of improved varieties, or of the more edible squashes, being made into pies, cooked as squashes are now cooked, or baked, the seeds and stringy matter having been removed. For winter use it was cut into strips and dried in the sun or in a warm room. At present it is mainly used to feed farm-animals, which eat it with avidity, though the seeds, being diuretic in their action, need to be first removed. This variety is of a rich orange-yellow color, and round shape with flattened ends, averaging about 14 inches long by 11 or 12 inches wide. The flesh is yellow, generally coarse-grained, and often stringy, yet still esteemed by many above the

improved varieties for making the favorite pumpkin pie of New England.

Of the varieties the Canada or Vermont pumpkin is one of the best for animal food, and of good quality for the table. It is of large size, oblate form with deep ribs, and a deep orange-yellow color. The flesh is much sweeter and less stringy than the common pumpkin. The cheese pumpkin is a remarkably vigorous and productive plant, the fruit large, much flattened, and deeply ribbed, its color a reddish-orange. The flesh is sweet and well flavored. There are several other



Sugar pumpkin.

varieties, the best of which for culinary purposes is the sugar pumpkin. This is of small size, being 8 or 9 inches broad and 6 deep, but is an abundant bearer and of excellent quality, being unsurpassed for pies and superior to many squashes for table use. The flesh of the pumpkin contains much sugar, and during the Revolutionary war it was boiled and the water evaporated to syrup by housewives, as a substitute for sugar. In addition to the diuretic action of pumpkin seeds, they are employed as an anthelmintic for the removal of tapeworm. (C. M.)

PURCELL, JOHN BAPTIST (1800-1883), Roman Catholic archbishop, was born at Mallow, Ireland, Feb. 26, 1800. He had received an academic education before he removed to the United States. Here he studied at Mount St. Mary's College, Emmitsburg, Md., supporting himself partly by gardening. After theological study at St. Sulpice he was ordained priest in the church of Notre Dame, Paris, May 21, 1826. Returning to Mount St. Mary's, he was appointed professor of moral philosophy and pastor of its congregation, and in 1829 became president. On May 19, 1833, he was appointed bishop of Cincinnati, and was consecrated in Baltimore cathedral October 13. He devoted himself with energy to the building and founding in all the growing cities of Ohio churches, orphan asylums, ecclesiastical seminaries, convents, and religious houses. In the city and suburbs of Cincinnati he founded 30 churches. He was also active in debates with religious leaders, the most noted of whom was Alexander Campbell (*q. v.*). In 1850 his diligence was rewarded by his promotion to the dignity of archbishop. He was loyal to the cause of the Union throughout the civil war. He attended the Vatican Council in 1870, and though he deprecated the promulgation of the Papal infallibility, he cordially embraced the dogma. For a few years longer his career continued to be one of success and prosperity in his work. But a great change came when it was discovered that the financial affairs of his see had been grossly and recklessly mismanaged. Trusted implicitly by thousands of Catholics, he had used the sums deposited with him in the buildings and support of ecclesiastical institutions, paying interest when asked, but making no proper provision for the return of the principal. His brother, Rev. Edward Purcell, whom he had called to assist him in his banking operations, had been

equally careless. In the financial distress which followed the crisis of 1873 the archbishop was unable to meet the numerous demands of his creditors. In December, 1878, he made a public assignment of his property for their benefit, endeavoring at the same time to retain for the church the use of many buildings. Much litigation ensued, and the civil courts in an equitable spirit examined the circumstances of the grants to churches. The claims proved amounted to \$3,672,371; large sums were lost by the ignorance of the depositors. Even after the bankruptcy the assignee also was found to have squandered part of the funds in speculation. Archbishop Purcell had retired from public view, and was succeeded by Archbishop Elder, of Natchez. He died at St. Martins, Ohio, July 4, 1883.

PUTNAM, FREDERICK WARD, naturalist and anthropologist, was born at Salem, Mass., April 16, 1839. His early fondness for natural history led him to become a student under Agassiz, who soon gave him charge of the collection of fishes in Harvard Museum of Comparative Zoology. In 1864 he took charge of the collections of the Essex Institute, at Salem, to which were afterwards added those of the East India Marine Society. In 1876 he became director of the Peabody Museum of American Archaeology and Ethnology. He had already edited vol. vii. of the *Report of Wheeler's Survey*, which treats of these subjects. Since 1873 he has been secretary of the American Association for the Advancement of Science, and has labored with great success to increase the number of its members and the value of its work. In 1886 he was made professor of ethnology in Harvard University. He was one of the founders of the *American Naturalist* in 1867, and one of its editors till 1875. He has also taught in Prof. Alexander Agassiz's summer school on Penikese Island, State commissioner of Massachusetts on inland fish, and in 1887 was chosen president of the Boston Society of Natural History. He has published more than 200 papers on American archaeology and anthropology. In 1888 he conducted successfully a movement for the purchase and preservation of the Great Serpent Mound in Ohio as a public park.

PUTNAM, ISRAEL (1718-1790), general, was born in that part of Salem now called Danvers, Mass., Jan. 7, 1718. His parents had twelve children, of whom he was the eleventh. With little education but of sturdy frame he in 1739 became a farmer at Pomfret, Conn. Already noted for courage, he enhanced his reputation by venturing into a she-wolf's den and killing the beast. In 1755 he was made a lieutenant of rangers and served in the expedition against Crown Point. In 1757 his coolness and courage prevented the explosion of the powder-magazine during a fire at Fort Edward. Romantic adventures with Indians marked his career. In 1758 they captured and bound him to a tree, and a fire was kindled around, when Marin, a French officer, intervened and saved him. Taken to Montreal, he received aid from Col. Peter Schuyler, a fellow-captive, and was finally exchanged. In 1762 he commanded a regiment in the expedition which captured Havana. He afterwards kept a tavern at Brooklyn, Conn., served some years in the Legislature, and in 1773 went to explore a tract of land on the Southern Mississippi supposed to have been granted by Parliament to the provincial officers. He was an ardent patriot, and in April, 1775, on learning of the fight at Lexington, he summoned the militia of his neighborhood and rode in one day 68 miles to Boston. The Legislature of Connecticut made him a brigadier-general, and with a regiment recruited by himself he joined the American army at Cambridge. This place he was resolute in holding, and when others advised falling back he urged an advance. After Col. Prescott had made intrenchments on Breed's Hill, Gen. Putnam sought to do the same at Bunker's Hill, and at the close of the battle, June 17, rallied some fugitives and took possession of Prospect Hill. Four major-gen-

erals were nominated by Congress for the Continental army, but Putnam was the only one to whom Washington on taking the chief command delivered the commission. After the evacuation of Boston Putnam went with Washington to the defence of New York city. He was to blame for the defeat suffered on Long Island, Aug. 27, 1776. In the winter he was called by Congress to superintend the fortification of Philadelphia, and after the battle of Princeton was stationed in New Jersey. In spring he took charge of the highlands of the Hudson, his chief duty being to watch the movements of the British from New York city. The capture of a lieutenant of a Tory regiment and Sir Henry Clinton's demand for his treatment as a British officer led to Putnam's famous letter:

"SIR:—Edmund Palmer, an officer in the enemy's service, was taken as a spy lurking within our lines; he has been tried as a spy, condemned as a spy, and shall be executed as a spy, and the flag is ordered to depart immediately. ISRAEL PUTNAM.

"P. S.—He has been accordingly executed."

After the loss of Forts Montgomery and Clinton in October, 1777, a court of inquiry was ordered and, though Putnam was declared free of blame, Washington, in deference to popular feeling, removed him from the command. He was stationed in Connecticut when Gov. Tryon, with 1500 men, made a raid into the State. Putnam with but 150 men faced him at Horseneck, and when obliged to retreat ordered his men to take refuge in a swamp, while he on horseback rushed down a steep declivity where the enemy's dragoons would not venture to follow. He afterwards harassed Tryon's retreat. In 1779 he returned to command in the Hudson Highlands and assisted in fortifying West Point, whose importance as a stronghold he had previously pointed out. In the following winter he was disabled by paralysis, and thenceforth remained on his farm, where he died May 19, 1790. His tombstone bears the inscription, "He dared to lead where any dared to follow." His *Life* was written by Gen. D. Humphreys (1790), by O. W. B. Peabody in Sparks's *American Biography* (1842), and by Increase N. Tarbox (1876).

PUTNAM, RUFUS (1738-1824), general, cousin of Israel Putnam, was born at Sutton, Mass., April 9, 1738. He became a millwright, but served as a soldier in the campaign against the French in 1757-60. On settling at New Braintree, Mass., he became proficient in surveying. In 1773 he took part in the expedition under Gen. Lyman to examine lands on the Southern Mississippi, supposed to have been granted to soldiers who served in the French war. On the outbreak of the Revolution he was lieutenant-colonel and displayed such ability in constructing defences at Roxbury that he won the esteem of Washington. In 1776 he was chief engineer of the defences of New York city, but, though Congress gave him that appointment with rank of colonel, he resigned to take command of a Massachusetts regiment. He fought at the battle of Stillwater and in 1778 with his cousin superintended the fortifying of West Point. At the close of the war he was made a brigadier-general. He assisted in quelling Shays's rebellion in 1787. Being made superintendent of the Ohio Land Company which he had been active in forming, he laid out Marietta, Ohio, in 1788. He was appointed a judge of the North-west Territory in 1790, and in 1796 U. S. surveyor-general. In Gen. Wayne's expedition against the Indians of Ohio Putnam was a brigadier-general and afterwards a commissioner to make a treaty with the tribes on the Wabash, which was done at Vincennes, Sept. 27, 1792. In 1803 Pres. Jefferson removed him from office. After serving in the Ohio Constitutional Convention in that year he held no public position. He died at Marietta, May 4, 1824.

PUTTKAMER, ROBERT VICTOR VON, a Prussian statesman, was born May 5, 1828, at Frankfort-on-the-Oder, his father afterwards becoming president of the

province of Posen. He attended the gymnasium of his native city and the real-gymnasium of Berlin. In 1846 he entered the University of Berlin and afterwards those of Heidelberg and Geneva, studying jurisprudence, political economy, modern languages, and history. After passing his first examination in the court of appeals at Marienwerder in 1850, he practised as auscultator in the court at Danzig; in 1851 he became court-referendary; in 1852 government referendary, and, after two years in this capacity in the administration of Posen, he rose, in 1854, to the post of government assessor. In the same year he was called to serve as assistant-adviser in the railroad department of the ministry of commerce. Here he was employed four years under the under-secretary of State Von Pommer Esche, whom, in January, 1859, he accompanied, as adviser-in-chief, to Coblenz. In 1860 he was appointed councillor of the district of Demmin and, during the war of 1866, he was civil commissioner of Moravia. On the conclusion of peace he entered, as assistant-minister, the department of the interior; thereafter he became consulting council in the newly founded bund-chancery. In 1871 he became government-president of Gumbinnen; in 1875 district-president of Lorraine; in 1877 chief president of Silesia. On the retirement of Minister Falk, in 1879, he undertook the office of minister of instruction with the purpose of furthering the negotiations between Pope Leo XIII. and the Prussian government for the promotion of peace between church and state. With this view he succeeded in passing a measure through the diet which empowered the ministry to set aside certain provisions of the "May laws." By his ordinance, dated Jan. 21, 1880, a reformed mode of spelling (called "Puttkamer's orthography") was introduced into Prussian schools. On June 18, 1881, he undertook the ministry of the interior, and, in October, was elevated to be vice-president of the Prussian state-ministry.

His cousin and brother-in-law, MAXIMILIAN VON PUTTKAMER, born in 1831, at Gross-Rossin in Pomerania, after studying law in Bonn and Berlin, passed through various offices, till, in 1879, he was named, as chief of the administration of justice, a member of the newly appointed ministry of Alsace-Lorraine. He began his parliamentary career as a member of the North-German constituent assembly in 1867, and belonged to the National-liberal party, but afterwards withdrew from it on the protective tariff question. In 1881 he was defeated as a candidate for re-election to the imperial parliament, but in the next year the entire administration of prisons and instruction, except public schools, was intrusted to him.

PYNCHON, WILLIAM (1590-1662), a settler of Massachusetts, was born at Springfield, Essex, England, in 1590. He was of ancient family and well educated. In the charter of the colony of Massachusetts Bay, granted by Charles I., March 28, 1628, he is named as one of the patentees and also as one of the assistants in governing the colony. In company with Gov. John Winthrop in 1630 he came to America and was one of the first settlers of Roxbury. Being wealthy, he engaged in the fur-trade with the Indians, and was made treasurer of the colony. In a few years many of the settlers desired to remove to the Connecticut River and Pynchon led a colony in 1636 to Springfield. The land was purchased from the Indians and he was made chief magistrate and so continued till 1651, being also for most of the time a member of the General Court. The change was occasioned by the publication of his book, *The Meritorious Price of Our Redemption* (London, 1650), in which he maintained that Christ did not suffer the punishment due to man's sins but by his perfect obedience procured man's redemption. The General Court pronounced the book heretical and called upon Rev. John Norton, of Ipswich, to answer it, which he did to their satisfaction. Meanwhile Pynchon had stated to the court that his views were somewhat modified after conference with Norton.

However being removed from the government and cited again to appear before the court, he left the colony in 1652 and fixed his residence at Wraybury, England. In 1655 his rejoinder to Norton appeared under the title, *The Meritorious Price of Man's Redemption*. In this he admits that the sufferings of Christ were appointed as a punishment for man's sins, but denies that Christ suffered the vindictive wrath of God or the pains of hell. Pynchon's other publications were *The Jews' Synagogue* (1652); *The Time when the First Sabbath was Ordained* (1654); *Holy Time; or the True Limits of the Lord's Day* (1654); *The Covenant of Nature made with Adam Described* (1661). He died at Wraybury, Oct. 9, 1662. But three copies of his first book are known to be in existence; one was sold at the Brinley sale for \$400. See Rev. Ezra H. Bixington's article on "William Pynchon" in the *Andover Review*, September, 1886.

His son, JOHN PYNCHON (1627-1703), succeeded to the management of affairs in the Connecticut Valley. He was for fifty years a magistrate of Springfield and was colonel of the Hampshire regiment. He was an "assistant" under the old charter of Massachusetts and a councillor under the new charter.

PYNCHON, THOMAS RUOGES, clergyman and educator, is descended in the seventh generation from the preceding. He was born at New Haven, Jan. 19, 1823, and was educated at the Boston Latin School. He graduated at Trinity College, Hartford, in 1841, and was tutor there 1843-47. He took orders in the Protestant Episcopal Church in 1848 and was rector of Stockbridge and Lenox, Mass., until 1855, when he returned to Trinity College as professor of chemistry. He was made president of the college in 1874. He has published an *Introduction to Chemical Physics* (1872), and several sermons and pamphlets.

Q.

QUAIL. See PARTRIDGE.

QUAIN, RICHARD (1816-1887), physician, was born at Mallow, Ireland, Oct. 13, 1816. His early education was in the diocesan school of Cloyne, and he was articled to a surgeon-apothecary in Limerick. In 1837 he went to London and entered the London University, whence he graduated M. B. in 1840, and M. D. in 1843. He served successively as house-surgeon and house-physician to the University College Hospitals. In 1846 he became a member of the Royal College of Physicians and in 1851 was elected a fellow. He was also elected a fellow of the Royal Society in 1871 and has held many other positions of responsibility and honor. From 1848 to 1875 he was connected with the hospital for diseases of the chest at Brompton, and afterwards was consulting physician. As member of the royal commission of the cattle plague he was active in directing the investigation, in determining the plan for its extinction and in securing public approval for this plan. His principal work is the *Dictionary of Medicine* (1882), and he also contributed valuable articles to medical journals and to the *Transactions* of learned societies. He was appointed in 1863 crown representative in the general medical council, and was several times reappointed. He died Sept. 17, 1887.

QUAKERS OR FRIENDS IN AMERICA. The arrival at Boston in July, 1656, of the English preachers, Mary Fisher and Anne Austin, was the first appearance of the Friends in America. The Massachusetts Colony immediately legislated (first in October, 1656) to suppress Quakerism. Fines, whipping, mutilation, imprisonment, banishment, etc., were provided in several successive laws, and that of October, 1658, prescribed death as a penalty for those returning after banishment. Under this, in 1659 William Robinson and Marmaduke Stevenson, and in 1660 Mary Dyer and William Leddra, were hanged on Boston Common, for persistence in remaining in the colony and preaching. Minor persecutions continued for many years. (An extensive literature, considerably enlarged in recent years, relates to the history of this subject, as viewed from the Puritan, the Quaker, and other stand-points.) All the other early colonies, except Rhode Island, also persecuted the Friends, but less severely than Massachusetts. Their preachers, however, continued to arrive from England, and the Society had members, by 1660, in Rhode Island, on Long Island, and in Maryland and Virginia, besides those who remained in Massachusetts. The first regular business meeting of importance is presumed to have been held in Rhode Island in 1661—an annual gathering. In

1671-72 William Edmundson and John Burnyeat, preachers of note from Great Britain, travelled through the Friends' communities, and did much to promote an organization of their meetings; and in 1672-73 George Fox visited the colonies from Rhode Island to North Carolina, further advancing this work. About 1670, or somewhat earlier, meetings were established in New Jersey, at Shrewsbury and elsewhere, and there were Friends in North Carolina about 1672. The purchase of West Jersey, in 1674, by the English Friends, and the grant of Pennsylvania to William Penn in 1681, brought companies of Friends to both banks of the Delaware. In 1675 they settled the town of Salem, and in 1677 Burlington, and in 1682 Philadelphia was laid out, and its building begun. Large immigrations of Friends and those in sympathy with them, such as the German Mennonites, followed to Pennsylvania in the next half century. In 1768 there were in all the North American provinces about 250 meetings for worship, distributed substantially as follows: Rhode Island and adjoining parts of Massachusetts, 48; Long Island and vicinity of New York city, 20; Pennsylvania, New Jersey, and Delaware, 111; Maryland, 20; Virginia, 26; and North Carolina, 11.

The changes in the Society since the colonial period may be briefly stated as follows: During the Revolutionary war a considerable but not relatively large loss of members was sustained, by the departure of those who took part in it from the peace testimonies of the Society. In New York and East New Jersey many of these sympathized with the mother country; in Pennsylvania and West Jersey the ratio was largely in favor of the colonies. About the close of the century and later, the North-western Territory being opened, an extensive migration of the North Carolina Friends took place, whole meetings going together to Ohio and Indiana. Similar movements of like character occurred from Eastern Pennsylvania to Upper Canada and to South-western Pennsylvania.

There had always been an extensive interchange of ministerial visits between Great Britain and this country. Between 1656 and 1818 the religious visits of British preachers to this country numbered 183; and the corresponding visits of American Friends to Great Britain (begun about 1693) numbered 110. About 1800, and from that date to 1825, the English preachers, influenced at home by the Evangelical movement begun by Wesley and others, began to find what they regarded as evidences of unorthodox views in this country, and they especially condemned the doctrines of Elias Hicks (1748-1830), a prominent minister of Long Island. In 1827 the Yearly Meeting of Phila-

delphia (by far the largest of the yearly meetings) divided, the minority basing their discipline upon orthodox doctrine. Other divisions followed in the Yearly Meetings of New York, Ohio, Indiana, and Baltimore. Those of New England and North Carolina did not divide, remaining with the Orthodox body.

Since 1830 several divisions have occurred among the Orthodox Friends, and they now form four bodies, as follows: (1.) Yearly meetings affiliating with each other and corresponding with London Yearly Meeting. This body is frequently designated as Gurneyite, from the fact that it sympathizes, generally, with the views of Joseph John Gurney, an English Friend (1788-1847), who visited this country in 1837-38, and whose views were opposed by John Wilbur, of Rhode Island, causing a division which extended to several yearly meetings within the following fifteen years. (2.) Yearly meetings of the "Wilbur" view, corresponding with each other, but not with any other of the Orthodox bodies, and not "recognized" by London. (3.) Philadelphia Yearly Meeting, which has avoided official commitment to either the Evangelical (or Gurney) views, on one hand, or the Wilburite on the other, and has sustained no division. It corresponds (1888) with no other body, though acknowledging the general relation of other Orthodox yearly meetings to itself, by receiving their members and ministers (the latter under carefully guarded rules, recently adopted). (4.) Smaller bodies, which have separated from the others, and have called themselves Primitive Friends, etc.

The body which did not disown the ministrations of Elias Hicks, in the controversy of 1827, remains unchanged, except by diminution. In the Western States, especially Ohio, Indiana, Iowa, and Kansas, the Orthodox (Class 1, above) have made considerable growth. They have adopted to some extent the methods of other churches, including prearranged services, salaried and stationed "pastors," singing during worship, etc., and some of their ministers have been baptized by immersion. They maintain missionaries in the West Indies, Mexico, and elsewhere. It is these methods, as well as doctrinal divergencies, which have caused the separation from them of the "Wilburite" and smaller bodies.

Statistics.—The census of 1880 stated the whole number of Friends in the United States at 95,966, with property valued at \$3,202,142, and 986 meeting places. These totals were divided as follows:

	No.	Val.	Prop.
1. Orthodox [including Philadelphia Yearly Meeting].....	66,738	\$1,951,847	33
2. "Hicksite".....	23,568	1,181,333	47
3. "Wilburite" Orthodox.....	4,742	41,285	1
4. Smaller bodies.....	618	27,677	0

The changes since 1880 in Classes 2, 3, and 4, above, have been unimportant. The Orthodox (Gurneyite) Evangelical body has made a growth in the Western States, by bringing in new members, mainly through "revival" methods. Its number (excluding Philadelphia Yearly Meeting) was estimated, 1887, at 72,500. It has ten yearly meetings in the United States and Canada: New England, New York, Canada, Baltimore, North Carolina, Ohio, Indiana, Western Iowa, and Kansas. The body, often called "Hicksite" (it is proper to say they disown this designation, and call themselves simply "The Religious Society of Friends"), has seven yearly meetings: Philadelphia, New York, Genesee, Baltimore, Ohio, Indiana, and Illinois. They have no meetings in New England or south of Virginia. Meetings have recently been organized in Nebraska, which is the farthest west. Their number is estimated, 1888, at 23,000, of which about half are in Philadelphia Yearly Meeting.

Several educational institutions of importance are in charge of the Friends. In the rank of colleges are Haverford, for young men, and Bryn Mawr, for young women, both near Philadelphia; Wilmington, at Wil-

ington, Ohio; Earlham, at Richmond, Indiana; and Penn, at Oskaloosa, Iowa—all belonging to the division called Orthodox. They have also several preparatory schools of note, the most prominent of which are those at Providence, R. I., and Westtown, Pa. The other principal body of Friends have Swarthmore College, near Philadelphia, for both sexes.

Bibliography.—For details concerning Friends in America, of the first importance is James Bowden's *History* (London, 1850); see also S. M. Janney's *History of Friends* (Phila., 1859); Janney's *Life of William Penn* (Phila., 1852); *Collection of Memorials* (Phila., 1787), and other collections of later date; T. Gilpin's *Exiles in Virginia* (Phila., 1848); *Account of the Conduct of Friends towards the Indian Tribes* (London, 1844); Michener's *Retrospect of Early Quakerism* (Phila., 1860); *Friends' Miscellany*, edited by John and Isaac Comly (12 vols., Phila., 1831-39); *Friends' Library*, edited by William and Thomas Evans (14 vols., Phila., begun 1837); R. P. Hallowell's *Quaker Invasion of Massachusetts* (Boston, 1883). There are many journals of ministers, one of the most notable being that of John Woolman, of New Jersey (1720-1772), of which many editions have been issued, one (Boston, 1882) edited by John G. Whittier. The questions arising out of the several divisions have given rise to a large number of controversial and doctrinal issues. Besides those relating to the division of 1827, others of interest are John Wilbur's *Narrative* (New York, 1845); and William Hodgson's *Society of Friends in the 19th Century* (Phila., 1876). (H. M. J.)

QUARANTINE. In the United States, and among civilized nations generally, this word no longer signifies "forty days'" detention p. 153 (p. 159 —it simply means "maritime sanitation"—and although still used to denote detention for an uncertain period (it may be only a few hours or at most a few days) it is now practised in connection with other measures employed by those in authority for placing the vessel, person, or thing detained in a thoroughly sanitary condition. (See SANITARY SCIENCE.)

"Shot-gun" quarantine is an unscientific if not a lawless procedure indulged in by panic-stricken inhabitants who, with deadly weapons in their hands, threaten to shoot any person from an infected district who seeks to enter or pass through their lines—*cordon sanitaire*. Although semi-barbaric and brutal, it exists in some parts of the United States to this day. (P. II. B.)

QUATREFAGES DE BRÉAU, JEAN LOUIS ARMAND DE, a French naturalist, was born at Berthezeme, Department of Gard, Feb. 10, 1810. He studied medicine and natural sciences at Strasburg and received his doctor's degree in 1829. He lived for some years at Toulouse, where in 1838 he was made professor of zoölogy. But he soon went to Paris, and in 1842 he commenced a series of scientific voyages along the Atlantic and Mediterranean coasts. In 1850 he was appointed professor of natural history in the Lycée Napoleon, and in 1856 exchanged this post for the professorship of anatomy and ethnology in the Museum of Natural History. His extensive investigations in zoölogy, comparative anatomy, and anthropology have afforded subjects for many works. Among the principal are *Études sur les types inférieurs de l'embranchement des annelés*; *Souvenirs d'un Naturaliste*, (1854); *Physiologie comparée, Métamorphose de l'Homme et des Animaux* (1862); *Histoire de l'Homme* (1864); *Charles Darwin et ses Précurseurs français* (1870); *La Race prussienne* (1871); *Crania æliica* (1875-79); *L'Espèce humaine* (1877). Miss E. L. Youmans translated his *Natural History of Man* (1875) and others of his works have appeared in English.

QUINCE. This plant, *Cydonia vulgaris*, so named from Cydonia, in Crete, its native place, is a well-known, hardy, deciduous fruit-tree, of the order *Pomaceæ*, being distinguished from the genus *Pyrus* by its leafy calyx lobes and the many-seeded cells of its fruit.

See Vol. XX. p. 182 (p. 188 A. M. Rep.).

It is a low, straggling tree, of from 8 to 15 feet high, with a crooked stem and twisted branches, a smooth, blackish bark, and large flowers with five red or white petals and twenty or more stamens. The fruit is large and globular or pear-shaped, of a rich yellow color when ripe, with a peculiar pleasant odor, which, when strong, many find disagreeable. The quince now grows spontaneously in the

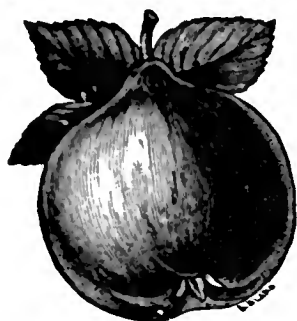

Meech's Quince.

the south of France and along the Danube. It was much esteemed by the ancients, who looked upon it as an emblem of love and happiness. There are several varieties, the most distinct being pear-shaped, which is thought the typical form, and which bears most abundantly. The apple-shaped quince, however, is most esteemed. The plant needs a rich, mellow soil, and well repays manuring. It is readily propagated from the seeds. Its most dangerous enemies are a borer, which is very destructive, and a peculiar yellow fungus, which attacks the young trees. It is much used as a stock for the budding of the pear, the Portugal variety being the best stock. The fruit is hard, with an austere taste, and is chiefly used for preserving with sugar and in the making of marmalades, jellies, etc. In England a wine is made from the juice. The mucilaginous seeds are employed in pharmacy and the toilet. The wood is hard, and is employed in turning.

Of the other species of *Cydonia* the Chinese quince is a very handsome tree, twenty feet high and of arborescent growth. The Japan quince, *C. Japonica*, is a low, straggling tree, but is valued as an ornamental plant, for the rich and abundant crimson blossoms which it bears in early spring.

QUINCY, a city of Illinois, county-seat of Adams co., is on the Mississippi River, 160 miles above St. Louis. It is on a limestone bluff, 125 feet above the river, and is an important railroad town. While Quincy Bay gives a fine harbor for steamboats, an important railroad bridge here crosses the stream. Quincy has a fine court-house which cost \$300,000, 2 opera-houses, 2 armories, numerous public halls, 7 banks, a cathedral and 35 churches, a medical college, several hospitals and asylums. Five daily and 8 weekly newspapers and 3 monthly magazines are published here. The industrial works comprise large flour-mills, saw- and planing-mills, stove-works, breweries, and factories producing carriages, furniture, sash, blinds, and tobacco. Quincy is finely laid out, has gas and electric light, street railways, good water-works and an excellent fire department. It was settled in 1822 and was made a city in 1839. In 1880 its population was 27,268.

QUINCY, the name of a family noted in the history of Massachusetts. JOSIAH QUINCY, Jr. (1744-1775), was renowned for his eloquent advocacy of the rights of the colonists. His son, JOSIAH QUINCY (1772-1864), in his long life was a prominent leader of the Federal party, afterwards mayor of Boston (1822-29), and a promoter of its improvements; then an able president of Harvard University (1829-45). The career of these distinguished men has been sketched in the *ENCYCLOPEDIA BRITANNICA*. Others of the family deserve mention.

EDMUND QUINCY (1681-1738) graduated at Harvard College in 1699. He was a member of the General Court and of the Governor's Council for many years. In 1718 he was made Judge of the Superior Court, and in 1737 went to England to conduct the case of Massachusetts in a boundary dispute with

New Hampshire. He died at London, Feb. 23, 1738, and the colony ordered a monument to be erected to his memory there.

Another EDMUND QUINCY (1808-1877), son of President Quincy, was born at Boston, Feb. 1, 1808. He graduated at Harvard College in 1827, and was secretary of the American Anti-Slavery Society. He published a novel, *Wensley* (1854), and a biography of his father (1867), and edited his father's *Speeches* (1875). He died May 27, 1877.

His brother, JOSIAH QUINCY (1802-1882), graduated at Harvard in 1821, studied law, and was active in the public affairs of Massachusetts. He was president of the State Senate in 1842 and mayor of Boston in 1845. In his term the water supply from the Cochituate was introduced. Other improvements were also promoted by him. Shortly before his death he contributed to the *Independent* sketches which have been collected under the title, *Figures of the Past* (1882).

His son, SAMUEL MILLER QUINCY, born in 1833, became a lawyer and edited the *Monthly Law Reporter*. Entering the army during the civil war, he rose from the rank of captain to that of colonel with the brevet of brigadier-general. He edited the *Reports of the Superior Court of Massachusetts, 1761-72* (1865), made by his great-grandfather, Josiah Quincy, Jr.

His brother, JOSIAH PHILLIP QUINCY, born in 1830, has published dramatic poems, *Lyleria* (1856), and *Charicles* (1856).

QUININE. The history of the manufacture of sulphate of quinine in the United States is interesting. The manufacture of this alkaloid was begun by John Am. Rep.). Farr, an eminent chemist of Philadelphia, in the year 1820. The process was crude though complicated, and, with the appliances then available, the manufacture of a few ounces was considered an important undertaking in chemical laboratory work.

Prior to the date mentioned all the quinine was imported at high cost. The record of the first authentic sale of quinine in the United States gives the price realized as \$200 per ounce, and Samuel Hart, a druggist of Philadelphia, as the seller. The date is not known, though believed to be 1815. The first lots sold by Mr. Farr were at \$8 per drachm.

The crude material (cinchona bark) was for many years received direct from the forests of South America, where the tree is of indigenous growth. The Peruvian government for many years enjoyed a monopoly of the trade in cinchona bark, and as the price was gradually advanced the manufacturing chemists extended their investigations. They soon discovered that lower grade barks from other sections could be used, and this resulted in a destruction of the monopoly. As the consumption of quinine increased, the question of future supply of the raw material became a serious one, as it was feared the supply could not be increased to keep pace with extending consumption. Fearing the exhaustion of the supply of bark in South America, the cultivation of cinchona trees was undertaken in Ceylon and Java, which, proving successful, an abundant supply is now assured. (See article CINCHONA in *ENCYCLOPEDIA BRITANNICA* and in this work.)

The successor to John Farr in the manufacture of quinine was the firm of Farr, Powers & Weightman, Philadelphia, which for many years was the only firm engaged in the business, though latterly the name has been Powers & Weightman. Two other firms of manufacturing chemists, in the same city, began at a later date the manufacture of the alkaloid, namely, Rosengarten & Sons and Kearby & Mattison. Still later the firm of Charles T. White & Co., of New York, engaged in the business, and, about 1885, a company was organized in the city of New York for the manufacture of this alkaloid. At no time, however, have there been more than four manufacturers of quinine in the

United States. After the removal of the duty on foreign quinine in 1879 the manufacturers could not compete with the imported article, and one after another abandoned the business, until, at the present time, but one firm continues the manufacture of quinine, and that is the oldest in the business.

About the time of the removal of the import duty on quinine, cheaper processes for the manufacture of the alkaloid were discovered, and the new sources of supply of the crude material furnishing bark of improved quality in unexpected abundance, the price declined steadily, and foreign competition has continued so active that the business has for several years been unremunerative. The imports of foreign quinine during the six years preceding the removal of the import duty averaged about 70,000 ounces per year. Since the removal of the duty the imports have increased steadily, reaching, in 1887, the enormous amount of 2,180,000 ounces. The imports of cinchona bark also show the effect of the competition of the foreign product. The total consumption of quinine in the world at the present time is estimated at 7,000,000 ounces per annum, and of this 3,000,000 ounces are consumed in the United States. Fully two-thirds of the quinine consumed in the United States is therefore of foreign manufacture, and none of the domestic made is now exported. Formerly there were considerable annual exports to Mexico and the South American states.

In the following table are given the highest and lowest prices of American quinine, per ounce, from 1823 to 1888 :

Year.	Highest.	Lowest.	Year.	Highest.	Lowest.
1823.....	\$20.00	\$16.00	1856.....	\$2.60	\$2.40
1824.....	14.00	12.00	1857.....	2.00	1.40
1825.....	8.00	8.00	1858.....	1.40	1.25
1826.....	7.00	5.25	1859.....	1.50	1.25
1827.....	7.50	6.00	1860.....	1.80	1.20
1828.....	6.00	3.25	1861.....	2.10	1.80
1829.....	2.90	2.25	1862.....	2.90	2.25
1830.....	2.50	1.75	1863.....	3.25	2.70
1831.....	1.50	1.35	1864.....	3.75	2.60
1832.....	1.00	1.75	1865.....	3.40	2.20
1833.....	1.87	1.70	1866.....	2.60	2.25
1834.....	1.80	1.25	1867.....	2.20	1.95
1835.....	1.65	1.60	1868.....	2.35	1.90
1836.....	1.58	1.45	1869.....	2.30	2.00
1837.....	1.40	1.40	1870.....	2.30	2.10
1838.....	1.90	1.60	1871.....	2.45	2.20
1839.....	3.30	2.75	1872.....	2.45	2.40
1840.....	3.12	2.87	1873.....	2.55	2.45
1841.....	2.62	2.50	1874.....	2.50	2.20
1842.....	2.00	1.60	1875.....	2.30	2.15
1843.....	1.80	1.55	1876.....	2.70	2.20
1844.....	3.00	2.00	1877.....	4.50	2.70
1845.....	2.40	2.35	1878.....	3.60	3.40
1846.....	2.40	2.20	1879.....	3.60	2.60
1847.....	2.40	2.30	1880.....	3.25	2.25
1848.....	2.70	2.60	1881.....	3.25	1.90
1849.....	3.65	2.95	1882.....	2.50	2.00
1850.....	3.70	3.70	1883.....	1.80	1.55
1851.....	3.25	3.25	1884.....	1.75	.90
1852.....	3.00	2.80	1885.....	1.05	.75
1853.....	3.20	2.70	1886.....	.80	.65
1854.....	2.50	2.50	1887.....	.70	.46
1855.....	3.00	2.60	1888.....	.56	.47

Over half a century's growth of the business of manufacturing quinine brought it to a prosperous condition, making it an important chemical industry. The past eight years has witnessed its decadence, until, at the present time, it is an unprofitable product among many in but one chemical manufacturing establishment, yet it is one of the most important articles of the *materia medica*, and its consumption continues to increase from year to year.

(H. G. A.)
QUITMAN, JOHN ANTHONY (1799-1858), a Southern general and politician, was born at Rhinebeck, New York, Sept. 1, 1799. He was the son of Rev. Frederick Henry Quitman (1760-1832), a Lutheran minister. After becoming a lawyer he removed to Ohio in 1820, but in 1823 settled at Natchez, Miss. Having won distinction at the bar he was made

chancellor of the Superior Court in 1828, and took part in the Constitutional Convention of 1831. For many terms he served in the Legislature, and in 1835 was acting governor of the State. The movement for the independence of Texas received his hearty support, and, when the Mexican war followed as its consequence, Quitman was one of the foremost volunteers. He commanded a division of Gen. Scott's invading army, and, when the city of Mexico was taken, he was made its governor until peace was concluded. In 1850 Quitman was elected governor of Mississippi, and gave every possible encouragement to the movement for the annexation of Cuba to the United States. (See CUBA.) But the administration at Washington baffled his schemes; by its order he was indicted in the U. S. Court at New Orleans, whereupon he resigned his governorship, to avoid an unseemly struggle between national and State authority. A new administration showed evident favor for Cuban annexation, but the plan remained in abeyance, while the struggle in Kansas demanded all the strength of the advocates of slavery extension. Quitman was obliged to forego the promised command of an army for liberating Cuba from the Spanish yoke. At the inauguration of Pres. Buchanan he led the military procession, and fondly hoped that the time had come for the realization of his cherished plans. Again disappointed, he died at Natchez, July 17, 1858.

QUO WARRANTO is the name of a writ by which the government commences an action to recover an office or a franchise from the p. 189 (p. 196 Am. Rep.) person or corporation illegally in possession of it. Formerly, in England,

the king, by virtue of his prerogative, sent commissions over the kingdom to inquire into all franchises granted by the crown; and if those in possession of them could not show a charter, the franchises were seized into the king's hands without any judicial proceeding. The statute of 6 Edw. I. prescribed the action of *quo warranto*, in which the writ commands the sheriff to summon the defendant to appear before the court and show (*quo warranto*) by what authority he claims the office or franchise. It is a proceeding to try the mere right to the franchise or office, where the possessor never had a right to it, or has forfeited it by neglect or abuse.

In the United States the writ of *quo warranto* has been superseded by what is called an *information* in the nature of a *quo warranto*, in form a criminal though in substance a civil proceeding. The person at whose instance it is instituted is called the relator. Proceedings referring to the usurpation of the franchises of a municipal corporation must be begun by the State through the attorney-general. In regard to the election of a corporate officer, however, the writ may issue at the suit of the attorney-general or of any person interested. It has been held in various States that *quo warranto* proceedings may be brought against members of a city council, a county treasurer, a sheriff, a governor or lieutenant-governor, a judge of probate, a presidential elector (proceedings being taken in the name of the United States), militia officers, etc. The State is not bound to show anything, but the defendant is bound to show a right to the office or franchise in question.

There are two forms of judgment—against an officer or individuals it is *ouster*; *i. e.*, that he or they be put out simply, for there is no franchise forfeited; against a corporation, by its corporate name, it is *ouster* and *seizure* of the corporate franchise. This is done on the principle that the franchise is a trust, of which the terms of the charter are the conditions; consequently, if any of the conditions be violated, it will work a forfeiture of the charter. Moreover, the corporate powers must be strictly construed, and exercised in the manner and form as well as by the agents prescribed in the charter.

Forfeitures may be brought about in two cases:

1. *In case of perversion*—as where a corporation does an act inconsistent with the nature and destructive of the ends of the grant; the perversion, however, must be such as to amount to an injury to the public, who are interested in the franchise. 2. *In case of usurpation*, as where a corporation exercises a power which it has no right to exercise; there is in such case no question as to injury to the public.

In England, corporations are the creations of the crown, and on dissolution their franchises revert to the crown; they may, however, be granted anew to the old corporators or to others. In the United States, corporations are the creatures of the Legislature, and on dissolution their franchises revert to the State. The Legislature has the same powers with respect to franchises as the English crown. (T. R.)

R.

RABBIT. The derivation of this name is by no means clear. The old Dutch *robbe*, the Walloon *robette*, and a local French form *rabette*, names for the European rabbit or the hare, are no doubt allied to this word. As to whether there is any connection between these names and the Portuguese *rabão*, "short-tailed," or the Spanish *rabito*, "a short tail," from *rabo*, "a tail," there is much room to doubt; and the rapidly progressing science of strictly historical and documentary philology can alone settle the questions.

It is well known that all the so-called rabbits native to North America are in reality hares. (See HARE.) The hares live and breed almost entirely in forms or rude nests, rather than in burrows, like the true rabbits. Moreover, the young at birth have a well-developed coating of hair and can see; while the true rabbits are born blind and hairless. The only true rabbit known in North America is the common domesticated rabbit introduced from Europe. Thus far, this animal has scarcely become naturalized in this country. Yet in Australia and New Zealand it has bred so rapidly in the wild state as to have become an intolerable pest and nuisance. There are parts of this country, like the Pacific States and the warmer parts of the South, where the climatic conditions are such as would seem favorable to the naturalization, on a hurtful scale, of the common rabbit; and reports have been printed of places in the Gulf States in which the animal is to be found in what might be called a half-wild condition. It is to some extent naturalized in tropical and South America. Among the hares miscalled rabbits in our country attention may be called to the so-called "jack-rabbits" or Jackass rabbits of the Far West. The large and very long-eared Texan hare (*Lepus Texanus*) appears to have been the first to receive this title. *L. callotis* of the South-west, and *L. artemisiae* and *L. Californicus* of the Pacific slope, are about equally remarkable with the Texan hare, in respect to development of the ears. But at present the name is generally given to *L. campestris*, the prairie-hare. One of our rabbits, *Lepus Bairdii*, from the Rocky Mountain region (probably only a variant form of the prairie hare) is, according to very respectable authority, distinguished among mammals as the only known species in which both male and female regularly produce milk and suckle their young. If this observation be correct, the anomaly may possibly be due to the scantiness of local vegetation, and the long duration of the summer droughts, which might very naturally reduce the secretion of milk in the female to such an extent as to call for a subsidiary supply from the male parent. Many exceptional cases of male lactation, even in the human species, have been reported; and there is no known reason why the male mammary gland, which in its structural elements is identical with that of the female, might not, under appropriate conditions, afford milk. (C. W. G.)

RABIES. See HYDROPHOBIA.

RACCOON. This familiar American animal is

well described in the *ENCYCLOPÆDIA BRITANNICA*. Besides the true raccoon, however, there are found in the South-western parts of the United States and in Mexico two interesting mammals, *Bassaris astuta* and *B. sumichrasti*, to which recent

authors give the name raccoon fox. The structure and other peculiarities of these creatures clearly mark them off from every other family of carnivorous mammals, and their true position has been much disputed. At present they are by common consent placed by themselves in a family, *Bassaridæ*; and they are generally assigned to a place among the *Arctoidæ* or bear-like animals. Among their popular names are coon-bear and civet. The ringed tail, arboreal habit, and playful, sociable disposition in captivity all prove a relationship to the raccoons; and in some parts of the country the raccoon fox is considered as a true raccoon—which it very certainly is not. The head and ears have a decidedly fox-like appearance. This little animal is easily tamed and soon becomes a great favorite in the frontiersman's cabin. The females are very much smaller than the males, and the males are smaller than the true raccoons.

RACINE, a city of Wisconsin, the seat of Racine co., is on the W. shore of Lake Michigan, 62 miles N. of Chicago and 23 miles S. of Milwaukee. It is the second city of the State in population and commerce. The Chicago and North-western and the Chicago, Milwaukee, and St. Paul Railroads as well as steamers on the lake in summer afford freight and travelling facilities. The city is on a plateau about 45 feet above the level of the lake, and is divided into two sections by Root River, across which there are five swing-bridges. It has a court-house, a handsome post-office building, a fine city-hall, 2 hospitals, 3 hotels, 3 national banks, 28 churches, 2 daily and 6 weekly newspapers. Besides the public schools, which have 6 large buildings, there are excellent private academies and the Church University of the North-west, which is under Protestant Episcopal control. This institution was founded in 1852 and was formerly known as Racine College. Taylor Orphan Asylum has a fine building about two miles from the heart of the city. The lumber trade of Racine is very large. Its manufactures comprise agricultural implements, pumps, wagons, cordage, furniture, fanning-mills, boots and shoes, rubber clothing, refrigerators, baskets, hardware, and wire work. It has also flour-, woollen-, and flax-mills, boiler-works, linseed-oil-works, etc. Racine was settled in 1834 by Gilbert Knapp, chartered as a village in 1841, and incorporated as a city in 1848. Its assessed valuation in 1886 was \$8,287,400; its public debt \$183,500 and its yearly expenses about \$150,000. The city is lighted with gas and electric light, has street railways, two parks and water-works and two artesian wells. It has twice suffered from large fires, in 1866 the loss being \$150,000, and in 1882 being \$800,000. In 1883 a destructive cyclone passed over the northern part of the city. There is a paid fire department, efficient and well supplied with apparatus. The population

was 16,031 in 1880, and by the State census of 1885 was 19,636.

RADISH, *Raphanus sativus*, a hardy annual originating in China, but now widely grown for its much-esteemed salad root. The plant when in flower is from three to four feet high, and bears large white or purplish flowers, and long smooth seed-pods. In Southern Asia the radish grows at a height of 16,000 feet on the Himalayas. In Norway it is cultivated beyond the latitude of 70°. All varieties succeed best in a light, rich, sandy loam, aided by manure rich in lime. The plant usually suffers in summer heat and drought, and when grown then the root is generally fibrous and very pungent. It is sometimes sown in beds of asparagus for the benefit of the shade and moisture. The root of the radish varies in shape from round or ovoid to a long tapering form. Its excellence consists in its succulent, crisp, and tender condition, qualities which can only be attained by rapid growth, so that the plant needs to be copiously watered in dry weather. Like most of the cruciferous salad plants, radishes are pungent and antiscorbutic. They are apt to be indigestible from their excess of woody tissue. The seeds of some varieties of the plant yield an oil almost identical with rape and colza oil. (C. M.)

RAFINESQUE, CONSTANTINE SCHMALTZ (1783-1842), an eccentric naturalist, was born at Constantinople, Oct. 22, 1783. His father was a French trader, and his mother, though born in Greece, was of a German family. In infancy he was taken to Marseilles and afterwards to Leghorn. He early developed a taste for natural science. In 1802 his father sent him to Philadelphia where he was employed in a counting-house, but his vacations were spent in rambling on foot in Pennsylvania and Virginia. In 1805 he went to Sicily to engage in business and for a time enjoyed a monopoly of the trade in squills, which he had discovered there. His labors in natural history are attested by his *Flora of Sicily* (1810), *Sicilian Ichthyology* (1810), and *Sicilian Crabs* (1814). The English ornithologist, William Swainson, paid a visit to Rafinesque in Sicily. In 1815 the latter returned to the United States, but on his voyage was shipwrecked near New London, Conn. His collection, manuscripts and drawings, were lost. He became a tutor in New York, but soon resumed his wanderings. In 1818 he was made professor of natural history and modern languages in Transylvania University, Lexington, Ky., but soon quarrelled with its authorities. He came in contact with Audubon, the ornithologist, who did not disdain to impose on the simplicity of the wanderer. Hence in his *Ichthyologia Ohioensis* (1824) appear some strange fish which have been a puzzle to later naturalists. Rafinesque's investigations were not confined to fishes and birds. He studied in his way the languages and customs of the Indians and projected various inventions. In 1830 he went to Philadelphia, and thenceforth published various magazines and histories, a poem called *The World: or Instability*, and a meagre autobiography called *A Life of Travel and Researches* (1836). He died at Philadelphia, Sept. 18, 1842. Rafinesque rejected the Linnæan system in botany and anticipated to some extent Darwin's theory. Between him and the naturalists of his time there was a strong repugnance, but Agassiz and a few of his successors have admitted some merit in his work. Many of his manuscripts are in the U. S. National Museum, but others are lost, and his publications are rare.

RAHWAY, a city of New Jersey, in Union co., is on the Rahway River, 4 miles from its mouth, and 19 miles S. W. of New York on the New York division of the Pennsylvania Railroad. It has 2 national banks, 2 savings banks, 18 churches, 2 weekly newspapers, and manufactures of carriages, wheels, axles, springs, printing-presses, shoes, and clothing. It was

settled in 1720, and incorporated as a city in 1858. Its population in 1880 was 6455.

RAILROADS IN THE UNITED STATES.—The subject of internal improvements, particularly that of improved means of internal communication for the colonists, was one that received considerable attention from the fathers of our country. The internal commerce of the United States, unlike that of any other country, has become almost wholly the creation of public works. The chief markets for its products, whether for home consumption or for exportation, are, and always have been, within a narrow strip of territory skirting the seaboard from Baltimore northward to Portland. The early settlements, from want of even ordinary highways, were necessarily made upon the navigable water-courses. When inland settlements were made the lack of suitable avenues for the transportation of their products to market was felt to be a serious check to their prosperity and progress. The subject engaged the attention of Washington at an early period in his life. He crossed the Allegheny range of mountains for the purpose of ascertaining whether a canal could be constructed from the navigable waters of the Chesapeake to the Ohio. Before the outbreak of the Revolutionary war, as a member of the House of Burgesses of Virginia, he urged the consideration of this subject upon that body. After the close of the war, and till his election as President of the United States, he was unremitting in his efforts to promote the construction of such works. He was president of the company first formed in Virginia to execute it. He also visited the State of New York, passed up the Mohawk to the summit from which the waters flow into the Hudson River on the one hand and into Lake Ontario on the other. At this point the Allegheny range falls off into a vast plain depressed 145 feet below the surface of Lake Erie, and 109 feet below the summit, which, near Chicago, separates the waters flowing into Lake Michigan from those flowing into the Mississippi. This physical feature, in one sense so unimportant, has exerted a paramount influence on the destinies, moral, political, and material, of the continent. It gave to the North the monopoly of its commerce, which brought supremacy in wealth, and in the West it made the lines of the Great Lakes the future seat of empire.

The first attempt to realize Washington's idea of binding by commercial interests the East and West was made, not in Virginia, but in the State of New York. In 1792 two companies—the "Western" and the "Northern Inland Navigation Company," of that State—were organized, the former undertaking the work of constructing what was termed a "lock navigation" from the Hudson to Lake Ontario, and the latter a similar work from Albany to Lake Champlain. The former constructed a canal which, being on a very small scale, proved wholly inadequate to its object, was unremunerative, and was speedily abandoned.

The next attempt of the kind grew out of the painful sense of the disasters suffered in the war of 1812, and in consequence of the difficulty in moving troops and munitions of war from the seaboard to the seat of hostilities in the line of the lakes and the St. Lawrence. The people of New York, in whose territory the war was chiefly waged, determined at its close to construct, with the least possible delay, a canal extending from the Hudson River at Albany to Lake Erie at Buffalo. On April 15, 1817, the Legislature passed an act, making provisions by means supplied by itself for the construction of such a canal, and on Nov. 14, 1825, the completion of the work was celebrated. (See CLINTON, DEWITT.)

From the success which followed the opening of the Erie Canal, the States of Pennsylvania, Maryland, Virginia, Ohio, and Illinois at once embarked on elaborate systems designed to give to almost every portion

of their respective territories the advantages of canal navigation.

Earliest Railroads.—The very year that the Erie Canal went into operation an event, hardly to be matched for its importance, occurred—the successful application on the Stockton and Darlington Railway of steam to purposes of locomotion. The railroad first undertaken in the United States was a short line of about three miles for the transportation of granite to the Neponset River, near Boston. This road was simply a copy of the tramroads already in use in England. It was important only as the pioneer of the great movement that was then taking place. A similar work was constructed about the same time for the transportation of coal from the pit's mouth to the Lehigh Valley Canal, near Mauch Chunk. It was not until 1828, however, that the construction of a railroad was undertaken for the transportation of freight and passengers on anything like a comprehensive scale. The construction of the Erie Canal had cut off the trade which Philadelphia had hitherto received from the West, and as the project of a canal from Baltimore to the Ohio was regarded by many as impracticable, the merchants of that city, in 1827, procured the charter of the present Baltimore and Ohio Railroad. On July 4, 1828, its construction was begun, the first act being performed by the venerable Charles Carroll, of Carrollton, the only surviving signer of the Declaration of Independence. At the close of the ceremony of breaking ground Mr. Carroll said: "I consider this among the most important acts of my life, second only to that of signing the Declaration of Independence, if even second to that." In the fall of 1829 the laying of the rails within the city of Baltimore was begun. On May 24, 1830, the first section of 14 miles, to Ellicott's Mills, was opened. Like all others constructed at the time, it was an unsubstantial structure, with longitudinal sills, on which was placed a thin bar or strap of iron. Although locomotive-engines had obtained some use in England, this road continued for nearly a year after its opening to be operated by horse-power. An ingenious but unsuccessful attempt was made to propel the trains by the use of sails. As some more efficient power than that of horses seemed indispensable, the company, on the 4th of January, 1831, invited proposals for the construction of a steam-engine for its use, "which, when in operation, must not exceed 3½ tons in weight, and must, on a level road, be capable of drawing 15 tons, inclusive of the weight of the wagons, 15 miles an hour." In response three engines were offered to the company. Only one was accepted as coming up to the required specifications. Although this engine was incapable of surmounting any considerable grades, it served to assure the officers of the company of the practicability of their working their railroad by steam-power. In the annual report of the company for 1831 its president, Philip E. Thomas, stated that "by many improvements made in the application of working power, an immense reduction in the cost of transportation and an increase in velocity had been effected."

The first locomotive ever used in the United States was one imported from England in 1829, called the "Stourbridge Lion." It weighed six tons. The engine was imported for use on the Carbondale Railroad, belonging to the Delaware and Hudson Canal Co., and extending from their canal to the mines. The first experimental trip was made by it Aug. 8, 1829. It was found too heavy for the track, and its use consequently had to be abandoned. The first locomotive built in this country, and the second in use in it, was called "The Best Friend of Charleston," having been built for use on the South Carolina Railroad, then in process of construction. It arrived at Charleston Oct. 23, 1830, and was placed on the road Nov. 2, 1830. The third, also constructed by the West Point Company, was placed on the Mohawk and Hudson, now a part of the New York Central Railroad, in 1831, and weighed three tons. It was used on the summit be-

tween the two planes worked by the stationary engines, that near Albany having a length of 3102 feet; that near Schenectady 2046 feet.

As early as 1832 the use of locomotives may be said to have been fairly established. From that time the comparative excellence of the engines' improvements was the only subject for consideration. Constant and rapid improvements were made in their construction. The locomotives first constructed weighed only from three to six tons, and were hardly capable of drawing on a level road half of the weight of the improved machine of the present day. No sooner was the superiority of the railroad over the ordinary highway fully demonstrated, both in this country and in England, than a great many schemes were immediately set on foot.

Following the Baltimore and Ohio Railroad, the next important line to be constructed was the South Carolina Railroad, extending from Charleston to Hamburg, opposite Augusta, Ga. This line was begun in 1830, and opened for traffic in 1833 for its whole length—135 miles. At that time it was the longest continuous line of railroad in the world. The construction of the Mohawk and Hudson, now a part of the New York Central, was begun in 1830. It was opened (17 miles) in 1831. The Saratoga and Schenectady Railroad (2½ miles) was opened in the following year; the Cayuga and Susquehanna (34 miles), connecting the Susquehanna River with Cayuga Lake, was opened in 1834; and the Reusselaer and Saratoga (25 miles) in 1835. In New Jersey that portion of the Camden and Amboy extending from Bordentown to Hightstown (14 miles) was opened Dec. 22, 1830, and between Hightstown and South Amboy (47½ miles) in 1834. In Pennsylvania a considerable extent of line for the transportation of coal had been constructed previous to 1835. In 1834 the Philadelphia and Columbia (82 miles) and the Portage Railroad (36 miles), the latter forming a part of the system of public works undertaken by the State of Pennsylvania, were opened. Their completion gave that State a continuous line, made up of canal and railroad, from Philadelphia to the Ohio River at Pittsburg. The total mileage of railroad constructed in that State to the end of 1835 was 318 miles, or nearly one-third of the whole extent of the line then in use in the United States. In 1833 the Baltimore and Ohio Railroad was extended as far west as Harper's Ferry (81 miles). In Massachusetts, in 1835, the Boston and Worcester Railroad (44 miles), the Boston and Providence (41 miles), and the Boston and Lowell (26 miles) were all opened for business. The total extent of mileage in operation in all the States at the close of the year 1835 was 1098 miles.

Only a moderate degree of success, either financial or commercial, attended the railroads first constructed in this country. They were rude and unsubstantial structures, involving a heavy outlay for repairs, and were very inadequate to the service even then required of them. The superstructure of the lines first constructed was a longitudinal sill, the rail or strap of iron laid upon it serving to prevent the abrasion of the wood rather than support the train. The change from wood to iron was a very gradual one. It was not until 1850 that the longitudinal sill and the flat rail were entirely removed from the Utica and Schenectady, the most important link in the New York Central line. Many of the early roads were upon routes having little traffic, and were consequently almost entirely unremunerative. Nevertheless the construction of railways was steadily persisted in. The total extent of mileage in operation in all the States at the close of the year 1835 was 1098 miles.

From 1835 the construction of railroads proceeded at the rate of about 400 miles annually until 1842, when the first work of the kind built for the express purpose of reaching and controlling the internal trade of the country was opened—the line from Boston to

Albany, connecting at the latter place with the Erie Canal. In the same year the last link in the line from Albany to Buffalo was opened. Nothing, however, was further from the minds of the parties opening this line than a competition for the business of the canals.

The most important railroads opened between 1835 and 1842 were the Philadelphia and Reading, to the coal-fields of Pennsylvania, opened in 1838; and the New Jersey Railroad, forming, in connection with the Camden and Amboy, a through line between New York harbor and Philadelphia, opened in 1840. The Baltimore and Ohio was opened to Cumberland, 179 miles, in 1842. At the end of 1848 the total mileage of all railroads in the country was 5996 miles, the average annual rate of increase from the date of their introduction being 316 miles.

RAILROAD CONSTRUCTION.

First Period.—The history of American railroad construction divides itself into four periods of activity, with two additional periods of inactivity intervening. The first period, from 1830 to 1848, may be termed the experimental period. In the following statement is shown the annual increase of railroad mileage during these 19 years:

Year.	Miles in Operation.	Increase of Mileage.
1830.....	23	...
1831.....	95	72
1832.....	229	134
1833.....	380	151
1834.....	633	253
1835.....	1,098	465
1836.....	1,273	175
1837.....	1,497	224
1838.....	1,913	416
1839.....	2,302	389
1840.....	2,818	516
1841.....	3,535	717
1842.....	4,026	491
1843.....	4,185	159
1844.....	4,377	192
1845.....	4,633	256
1846.....	4,930	297
1847.....	5,598	668
1848.....	5,996	398

Of the total mileage completed in 1848, 1225 miles were in New England, 2350 in the Middle States, 419 in the Western States, and 1415 in the Southern States. Pennsylvania led the States with 1048 miles, New York following with 869 miles, and Massachusetts coming third with 790 miles.

During this experimental period the progress of railroads was slow and unpromising. Their construction, maintenance, and improvement had absorbed all the floating capital of the country. Converting vast amounts of mobilized funds into fixed capital, it helped to prepare the way for those terrible financial hurricanes which swept over the country in 1837 and 1847. Small as was the progress made it imposed too heavy a burden on the financial machinery of the nation; for so rudimentary was the industry of the country, and so slow its rates of increase, that the best located lines, instead of creating as they now do an annual traffic much exceeding their cost, were a heavy charge upon their promoters and stockholders.

The discovery in 1848, immediately after its annexation to the United States, of deposits of gold of marvellous richness in California created an excitement hardly less universal and intense than that which followed their first discovery in the New World. The effect upon the industries and commerce of the country of the sudden addition of more than \$50,000,000 annually to its circulating medium was prodigious. A new field was opened which absorbed no inconsiderable portion of the labor of the country at most remunerative rates. All sections were proportionately benefited. For the newly created enterprise of the nation the

railroad offered the most attractive and appropriate field. Foreigners shared fully with ourselves in the enthusiasm which prevailed and proffered almost unlimited sums for the prosecution of our public works.

Second Period.—From the discovery of gold in California in 1848 dates the second period in the history of railroad construction. Then began the great movement, which has since suffered no considerable check, and which has resulted in building up, in the New World, in the incredibly short period of 40 years, the most powerful, wealthy, and progressive nation in the universe.

The following statement exhibits the progress made annually in railroad construction in the whole country from 1849 to 1860:

Year.	Miles in Operation.	Increase of Mileage.
1849.....	7,365	1,369
1850.....	9,021	1,656
1851.....	10,982	1,961
1852.....	12,908	1,926
1853.....	15,360	2,452
1854.....	16,720	1,360
1855.....	18,374	1,654
1856.....	22,016	3,642
1857.....	24,503	2,487
1858.....	26,968	2,465
1859.....	28,789	1,821
1860.....	30,635	1,846

On the first day of January, 1849, a continuous line of railroad was first formed between Boston and New York by the completion of the New York and New Haven Railroad. In the spring of 1851 the Erie Railroad was completed from the harbor of New York to Lake Erie—an event of first-rate importance in the commerce of the country. In the same year a continuous line of railway was opened between Boston and the St. Lawrence, by the completion of the Vermont Central and Vermont and Canada Railroad—the line from Ogdensburg to Lake Champlain having been opened in 1850. In the fall of 1851 the Hudson River Railroad was completed, giving to the city of New York a second line of railway to the great lakes; but some ten years after the city of Boston had secured such a connection.

In 1852 another important extension of the railway system of the country was made by the completion of the Michigan Central and Michigan Southern Railroads, from Lake Erie to Chicago. The lake served as a connecting link till 1853, when, by the opening of the Cleveland and Toledo Railroad, a continuous line of 1000 miles of railway was formed between New York and Boston and Chicago.

The preceding sketch has traced the progress westward of the great trunk lines based upon Boston, New York, Philadelphia, and Baltimore. Some progress had been made, however, in the Valley of the Ohio, before either of these lines had reached that river or Lake Erie.

The first line of railroad undertaken in the great interior basin of the country was the Mad River and Lake Erie of Ohio, now a part of the Cincinnati, Sandusky, and Cleveland Railway. Its construction from Sandusky to Dayton, 154 miles, was begun in 1835, a portion of it being opened in 1838. In connection with the Little Miami, which was opened from Cincinnati to Springfield in 1846, it formed, in 1848, a part of the first through line opened from Lake Erie to the Ohio. A second line between the lakes and river was formed by the Little Miami and the Cleveland, Columbus, and Cincinnati, which was completed between Cleveland and Columbus, 135 miles, in 1851. The Cleveland and Pittsburg, forming the third line, was opened in 1852. These roads opened up the greater part of the State of Ohio to transportation by railroads, and supplemented the trunk lines westward, so soon as the intermediate links could be put in. This was accomplished by the completion of the line of rail-

road from Buffalo to Toledo, the last link of which, between Cleveland and Toledo, was opened in 1853. Of the lines running east and west through that State the first to be constructed was the Central Ohio, which was opened from Wheeling to Columbus, 137 miles, in 1851. The Marietta and Cincinnati Railroad was begun in the spring of 1851, and six years later was completed from Marietta, on the Ohio River, to Loveland, 173 miles; entrance into Cincinnati, 6 miles beyond Loveland, being made over the tracks of the Little Miami Railroad. In 1857, the same year that the Marietta and Cincinnati was completed, the Baltimore and Ohio reached the Ohio River at Parkersburg by the construction of its Parkersburg branch, and two years later a branch of the Marietta and Cincinnati was built to meet the latter line, thus forming a through line from Baltimore and Washington to Cincinnati. In 1858 the Pittsburg, Fort Wayne, and Chicago Railroad Company opened its important line from Pittsburg to Chicago, a distance of 468 miles, completing the second great trunk line from New York to Chicago.

As in Ohio there were no railroads of importance constructed in the other Western States of the Union previous to 1849. In Indiana the Madison and Indianapolis (now a part of the Jeffersonville, Madison, and Indianapolis), one of the roads first constructed in the West, was opened in 1847. This line was originally begun by the State and 26 miles opened in 1841. It was transferred to a private corporation in 1843 and completed between Madison and Indianapolis in 1847. The first line running east and west through the State, made up of the Indiana Central and the Indianapolis and Terre Haute, was opened in 1853. The next line, having a similar direction, was the Ohio and Mississippi, opened in 1857. The New Albany and Salem, now the Louisville, New Albany, and Chicago, the first line connecting Lake Michigan and the Ohio, and lying wholly in Indiana, was opened in 1854.

In Illinois the first line undertaken was the Sangamon and Morgan, a portion of which was opened as a State work in 1839. This road now forms a part of the Wabash line. The second line opened in Illinois was the Galena and Chicago Union, which was commenced in 1849, and opened for a distance of 10 miles in June, 1850. The railway first opened in this State from Lake Michigan to the Mississippi River was the Chicago and Rock Island, in February, 1854. This connection marked a very important extension of the railway system of the country. The second line to the Mississippi, made up of the Galena and Chicago and the Illinois Central, was opened early in 1855. The Chicago and Alton was opened in 1855; the Chicago, Burlington, and Quincy to the Mississippi River in 1856; the Milwaukee and St. Paul in 1858; and the Western Union in 1862. Both of the latter now form part of the Chicago, Milwaukee, and St. Paul system. The Chicago branch of the Illinois Central was opened from Chicago to Cairo in 1856. At this time the Illinois Central, with its 700 miles of road, was considered the most stupendous undertaking in the world.

The next important extension westward was the Hannibal and St. Joseph, which carried the railway system to the Missouri River in 1859.

Of the lines constructed through Central and Southern Illinois the Terre Haute and Alton was opened in 1854 and the Ohio and Mississippi in 1857. From St. Louis, westward, the Pacific Railroad of Missouri, the beginning of the present Missouri Pacific system, was completed to Sedalia, 189 miles, in 1861—before the outbreak of the war.

The railroads whose progress has been here sketched formed at this date, geographically and commercially, one system, of which the Baltimore and Ohio Railroad and its connecting lines may be said to constitute the southern boundary or member. South of Baltimore there was no important commercial city upon the Atlantic coast, and the trade of all the interior north of

a line coincident with the lower Ohio naturally sought eastern outlets through the railways that had been opened. In consequence, the railroad development of the Southern States during the earlier periods was slow and of local importance only.

Several railroads were constructed at an early day in Virginia, the more important of which were those now forming the line traversing the State from North to South, and made up of the Richmond, Fredericksburg, and Potomac, completed from Richmond to Fredericksburg in 1837, and to the Potomac in 1841; the Richmond and Petersburg, opened in 1838; and the Petersburg and Roanoke, in 1843. But the great line of Virginia, prior to the civil war, was the railway traversing the State diagonally from Alexandria to the boundary line of Tennessee, 382 miles, made up of the Orange and Alexandria and the Virginia and Tennessee Railroads. The former of these roads was opened in 1859 and the latter in 1856. At the boundary it connected with East Tennessee and Virginia, extending to Knoxville, Tenn., which was opened in 1858. From Knoxville this line was extended to Dalton, on the line of the Western and Atlantic Railroad, by the East Tennessee and Georgia Railroad, opened in 1856.

From Weldon the Virginia system was extended to Wilmington, N. C., by the opening of the Wilmington and Weldon Railroad in 1840. It was not till 1853 that a connection was formed with the system of South Carolina by the opening of the Wilmington and Manchester Railroad. The South Carolina Railroad, as before remarked, was opened to Augusta, Ga., in 1833. From Augusta the Georgia Railroad was opened to Atlanta in 1839. The Central Railroad of that State was opened from Savannah to Macon in 1840. From Atlanta the railway systems of South Carolina and Georgia were extended to the Tennessee River at Chattanooga, Tenn., by the completion of the Western and Atlantic Railroad of Georgia, a State work, in 1850. From Atlanta a line of railway was opened to Montgomery, Ala., in 1853, and from Montgomery to Mobile, in the same State, in 1862.

From Chattanooga to Nashville the Nashville and Chattanooga was opened in 1854, and the Memphis and Charleston in 1857. The Mobile and Ohio Railroad was opened to Columbus, on the Mississippi River, near the mouth of the Ohio River, in 1859. The line from New Orleans, made up of the New Orleans, Jackson, and Great Northern, and the Mississippi Central, was opened to a connection with the Mobile and Ohio, at Jackson, Tenn., the same year. The Louisville and Nashville was opened to a connection with the roads last named in 1861, and with Nashville in 1859.

In the first period of 19 years there had been constructed in the United States, as already shown, 5996 miles of railroad, only 419 miles of which were in the Western States. In the second period, covering the 12 years from 1849 to 1860, there were added 24,639 miles of new railroad, making the total at the end of the latter year 30,635 miles, the increase over 1848 exceeding 400 per cent., and averaging annually over 2000 miles, as against an average of 316 in the experimental period.

The *third period* of the history of railroad construction was the first period of inactivity during the civil war. From 1861 to 1864 railroad construction was virtually suspended, the total additions during that time being only 3273 miles, of which 133 miles were in New England, 1235 in the Middle States, 1433 in the Western States, 143 in the Pacific States, and 329 in the Southern States.

Fourth Period.—The next period is that from 1865 (the close of the war) to the panic of 1873. In it the railroad mileage of the country expanded more than 100 per cent., increasing from 33,908 miles at the close of 1864 to 70,268 miles in 1873. This period covers what may be termed the Pacific Railroad era of the

United States. The railroads undertaken with the aid given by Congress were the most important of the period, or, more properly, the most important enterprises of the kind in the country's history. It was due to their undertaking that such an unprecedented stimulus was given to railroad construction; and the panic of 1873 resulted from the same cause as much as from any other special incident.

THE PACIFIC RAILROADS.

The project of a railroad to the Pacific Coast was first brought to the attention of Congress by Asa Whitney, of New York, in 1846 (antedating by two years the discovery of gold in California), in a memorial asking government aid for the building of a railroad from Lake Michigan to Portland, Oregon. It is a remarkable fact that this proposed route was substantially that followed by Lewis and Clarke's expedition to the Pacific, which was dispatched overland by Pres. Jefferson to examine and report upon the newly acquired Northwest Territory, shortly after the Louisiana Purchase in 1803, and that which was later practically adopted by the incorporators of the Northern Pacific Railroad Company. Whitney's proposition to Congress was for aid in the form of a grant of land on both sides of the proposed road. He asked no subsidy or pecuniary guarantees of any kind, relying upon his ability to dispose of the land to provide the means necessary for the successful prosecution of the work. His proposition was discussed in committee and in Congress, but his persistent efforts met with no reward beyond these respectful considerations.

Renewed interest was given to the scheme by the gold discoveries, yet all efforts to further the project were unavailing owing to the widespread prejudices of that time against granting his petition. For 2000 miles this proposed route lay through the public domain. According to a prevailing construction of the Constitution the nation was incapable of aiding such works or of even granting charters for their construction. Congress, however, yielded to the popular demands so far as to appoint commissions to survey other routes for national highways to the Pacific. The project continued to be a prominent subject of discussion until by 1860 public interest had been so thoroughly enlisted in it that both political parties at their national conventions in that year adopted resolutions in favor of granting government aid to an enterprise of this character. But the events immediately following the election of 1860 forbade the consideration at that time of any enterprise involving so large an outlay of money. The outbreak of the rebellion established emphatically the positive need of such a road as a war measure if for no other purpose. The Pacific Slope was loyal and the North, then in control of the government, determined to render that loyalty a matter of interest as well as sentiment.

On July 1, 1862, Congress passed an act chartering the Union Pacific Railroad Company, with authority to construct and operate a railroad and telegraph line from the Missouri River in the direction of San Francisco, or to a junction with the railroad of the Central Pacific of California, a company already chartered and organized under the laws of that State, and authorized by the same act to construct a railroad through the Territories of the United States, so as to form, in connection with the Union Pacific, a continuous line from the Missouri River to the Pacific Ocean. The route thus selected was one of those which had been surveyed by direction of Congress. The act provided for grants to both companies of right of way 200 feet wide, over the public domain; of alternate sections of land within 20 miles of the lines of the two roads; and of the bonds of the United States bearing interest at the rate of 6 per cent., payable in 30 years, and secured by a first mortgage on the roads, the bonds to be issued in ratio to the cost of construction of the several portions of the two lines; the amount finally issued being

\$27,236,512 to the Union, and \$27,855,680 to the Central Pacific. In consideration of these grants the two companies were to complete their roads by July 1, 1876; to transport troops, munitions of war, etc., for the United States at rates as favorable as those charged to individuals; to allow the use of its telegraph on similar terms; to pay into the treasury of the United States 5 per cent. of the net earnings of their respective roads, and allow the government to retain the whole of the charges for transportation on its account—the two sums so provided to be applied to the payment of the principal and interest as it accrued of the government bonds. At the maturity of these bonds the companies were to pay them, with such balance of interest as might then be due.

The act of 1862 did not secure its objects. The Union Pacific Company was organized as provided, but no one was to be found, as matters stood, to venture money in the construction of this road. Upon such representation, Congress, on July 2, 1864, amended the act of 1862, by making provisions more favorable to the companies, the chief of these being preference, by way of security, to an amount of bonds to be issued by both companies equal to those to be issued to them by the United States, and providing that the government should pay over to them one-half of the charges for services on its account. Under such provisions the two companies entered energetically upon the work of construction, and united their lines May 10, 1869, anticipating by more than seven years the time required by Congress therefor; the Union Pacific constructing 1034, and the Central Pacific, beginning at Sacramento, 743 miles.

The following statement shows the number of miles constructed annually by each company, and the total mileage for each year:

Years.	By Union Pacific.	By Central Pacific.	Total constructed.
1865.....	40	56	96
1866.....	265	38	303
1867.....	245	44	289
1868.....	350	362	712
1869.....	134	243	377
Totals...	1,034	743	1,777

The road of the Central Pacific was subsequently extended from Sacramento to San Francisco, a distance of 140 miles; the total length of line from the Missouri River to that city being 1917 miles; and from the harbor of New York, 3322 miles. Its general direction is almost exactly east and west, very nearly upon the parallel of 40°, or that of New York, Chicago, Salt Lake City, and San Francisco.

A connection with the eastern system of railroads had been provided in 1866 by the completion in that year of the second line of railroad between the Mississippi and Missouri Rivers, made up of the Chicago, Iowa, and Nebraska, and the Cedar Rapids and Missouri River Railroad, which completed the connection between Clinton, Iowa (the western terminus of the Galena and Chicago Union), and Council Bluffs, Iowa, opposite Omaha (the initial point in the Union Pacific line).

The Northern Pacific Railroad Company, whose line follows what is known as the Northern or 47th parallel route, was the second company chartered by Congress to build a transcontinental railroad. The charter was granted July 2, 1864, and the company was authorized to construct a railroad from Lake Superior to Puget Sound, a distance of about 1800 miles, with a branch from Puget Sound to the Oregon River, a distance of about 200 miles. By the act of incorporation the company was to receive the odd sections of government lands lying within forty miles of each side of the line of its road. With deductions for previous sales, water, Indian reservations, &c., etc., the grant, as estimated by the Land Department at Washington, equalled

TABLE I.—Miles of Railroads in the United States.

	1835.	1840.	1845.	1850.	1855.	1860.	1865.	1870.	1875.	1880.	1885.	1886.	1887.
<i>New England:</i>													
Maine.....		11	62	245	415	472	521	786	980	1,005	1,136	1,150	1,160
New Hampshire.....		53	92	467	67	661	667	736	934	1,015	1,044	1,050	1,085
Vermont.....				290	529	554	587	614	810	914	947	947	940
Massachusetts.....	113	301	567	1,035	1,264	1,264	1,297	1,480	1,817	1,915	1,998	2,018	2,066
Rhode Island.....		50	50	68	108	108	125	136	179	210	210	210	214
Connecticut.....		102	202	402	496	601	637	742	918	923	976	976	993
Group I., Total.....	113	517	973	2,507	3,469	3,660	3,834	4,494	5,638	5,977	6,310	6,350	6,459
<i>Middle Atlantic:</i>													
New York.....	104	374	721	1,361	2,583	2,682	3,002	3,928	5,423	5,991	7,385	7,481	7,508
New Jersey.....	99	186	186	206	466	560	864	1,125	1,511	1,684	1,921	1,957	1,954
Pennsylvania.....	318	754	798	1,240	1,800	2,598	3,728	4,656	5,705	6,191	7,667	7,872	8,019
Delaware.....	16	39	39	39	56	127	134	197	272	275	316	334	304
Maryland & D. C.....	117	213	259	259	327	386	446	671	929	1,040	1,211	1,247	1,189
Group II., Total.....	654	1,560	2,003	3,105	5,232	6,353	8,174	10,577	13,840	15,181	18,500	18,891	18,969
<i>North Central:</i>													
Ohio.....		30	84	575	1,486	2,946	3,331	3,538	4,461	5,792	7,338	7,456	7,546
Michigan.....		59	238	342	474	779	941	1,638	3,346	3,938	5,269	5,036	6,462
Indiana.....			30	228	1,406	2,163	2,217	3,177	3,963	4,373	5,600	5,711	5,834
Illinois.....			22	111	887	2,790	3,157	4,823	7,109	7,851	8,905	9,276	9,601
Wisconsin.....				20	187	905	1,010	1,525	2,566	3,155	4,418	4,869	5,283
Group III., Total.....		89	374	1,276	4,440	9,583	10,656	14,701	21,445	25,109	31,530	32,948	34,726
<i>South Atlantic:</i>													
Virginia.....	93	147	228	384	912	1,379	1,401	1,486	1,608	1,893	2,698	2,730	2,778
West Virginia.....			97	97	241	352	365	387	615	691	1,039	1,147	1,230
North Carolina.....		53	87	283	582	937	984	1,178	1,356	1,486	2,028	2,202	2,318
South Carolina.....	137	137	204	289	759	973	1,007	1,139	1,335	1,427	1,687	1,814	1,884
Georgia.....		185	516	643	1,020	1,420	1,420	1,845	2,264	2,459	3,116	3,390	3,490
Florida.....				21	21	402	416	446	484	518	1,603	1,918	2,178
Group IV., Total.....	230	522	1,127	1,717	3,535	5,463	5,598	6,481	7,662	8,474	12,166	13,201	13,878
<i>South Central:</i>													
Kentucky.....	15	28	28	78	242	534	567	1,017	1,326	1,550	2,010	2,117	2,275
Tennessee.....				466	1,253	1,296	1,492	1,630	1,843	2,158	2,158	2,199	2,463
Alabama.....	46	46	46	183	334	743	805	1,157	1,800	1,843	2,226	2,280	2,713
Mississippi.....			42	75	278	862	898	990	1,018	1,127	1,920	2,111	2,133
Louisiana.....	40	40	40	80	203	335	335	450	466	652	1,370	1,381	2,249
Group V., Total.....	101	114	156	416	1,523	3,727	3,901	5,106	6,240	6,995	9,684	10,089	10,833
<i>South-Western:</i>													
Missouri.....				139	817	925	2,000	2,905	3,965	4,969	5,068	5,068	5,463
Arkansas.....					38	38	256	740	859	2,146	2,196	2,196	2,375
Texas.....				40	307	465	711	1,685	3,244	6,687	7,295	7,889	7,889
Kansas.....						40	1,501	2,150	3,400	4,441	6,119	8,115	8,115
Colorado.....							167	807	1,570	2,884	2,044	3,911	3,911
New Mexico.....								758	758	1,195	1,231	1,234	1,234
Indian Territory.....								275	289	353	432	432	880
Group VI., Total.....				179	1,162	1,468	4,625	8,562	14,085	22,675	25,287	25,287	29,867
<i>North-Western:</i>													
Iowa.....				68	655	891	2,683	3,850	5,400	7,504	7,935	8,323	8,323
Minnesota.....						213	1,092	1,990	3,151	4,331	4,823	5,065	5,065
Nebraska.....						122	705	1,167	1,953	2,988	3,616	4,892	4,892
Dakota.....							63	275	1,225	2,877	3,098	4,324	4,324
Wyoming.....							459	459	812	617	778	877	877
Montana.....									106	1,047	1,062	1,684	1,684
Group VII., Total.....				68	655	1,226	5,004	7,741	12,347	19,364	21,912	25,165	25,165
<i>Pacific:</i>													
California.....				8	23	214	925	1,503	2,195	3,044	3,297	3,726	3,726
Oregon.....						19	159	248	508	1,181	1,219	1,274	1,274
Washington Terr.....								110	289	736	896	1,030	1,030
Nevada.....							593	601	739	954	954	931	931
Arizona.....									349	906	989	1,060	1,060
Utah.....							257	506	842	1,139	1,139	1,149	1,149
Idaho.....									206	798	811	845	845
Group VIII., Total.....				8	23	233	1,934	2,968	5,128	8,758	9,307	10,015	10,015
United States, Total.....	1,098	2,818	4,633	9,021	18,454	30,626	35,085	52,922	74,096	98,296	128,987	137,086	146,912

47,000,000 acres, or 73,000 square miles—an area larger than the States of Ohio and Indiana, and equal to a belt of land 40 miles wide and 1850 miles long. The grant was conditioned upon the construction of the road within a period of 15 years, or by the 4th of July, 1879. Lands, however, in the ratio of the whole grant to the mileage, were to be certified to the company as fast as the construction progressed—that is, upon the completion of sections of 20 miles each.

By act of Congress, approved July 27, 1866, the Atlantic and Pacific Railroad Company was chartered to construct a railroad on the 35th parallel route from Springfield, Mo., to the Pacific Ocean, about 2000 miles, across the Indian Territory, Texas, New Mexico, Arizona, and California, as a main line, and from Van Buren, Ark., to the point where the main line strikes the Canadian River in the Indian Territory as a branch line. To this company Congress granted lands to the extent of 12,800 acres per mile of road in the States and 25,600 acres per mile of road in the Territories. The land grant to this road called for 42,000,000 acres, or about 70,000 square miles.

The next Pacific railroad chartered by Congress was the Texas Pacific Railroad Company, which was incorporated by act of March 3, 1871, and authorized to build from Marshall, Texas, to El Paso, thence through New Mexico and Arizona to a point on the Rio Colorado, at or near the south-western boundary of California, and thence to San Diego. This was the most southerly route of all lines chartered, and is known as the 32d parallel route. Its land grant was of the same proportion per mile as that of the Atlantic and Pacific—12,800 acres in the States and 25,600 acres in the Territories.

Upon none of these roads was any considerable progress made in building in the period now under consideration—that is, from the close of the war until the panic of 1873. A vigorous effort was made toward the extension and completion of the Northern Pacific, and in three and one-half years from the beginning of work, July, 1870, to the date of default on its interest payments, Jan. 1, 1874, there had been completed and opened for business 424 miles of road on the eastern end—from a point 23 miles west of Duluth westward to the Missouri River in Dakota—and on the western end 65 miles from Kalama to Tenino. The Atlantic and Pacific Railroad was able to complete only 125 miles of its line—from Springfield west—before the suspension of work, while on the Texas Pacific work had been only just begun.

In New England during this period railroad mileage increased nearly 2500 miles; in the Middle States the increase was 6070 miles, about 75 per cent.; in the South it increased 4000 miles (44 per cent.), and in the Pacific States the increase was from 166 miles to 2193 miles. But the great increase of this period was in the Western and South-western States, as is shown in the following statement:

	1873.	1864.		1873.	1864.
Ohio	4,258	3,311	Wyoming.....	459
Michigan.....	3,253	898	Utah.....	372
Indiana.....	3,714	2,195	Dakota.....	275
Illinois.....	6,589	3,156	Colorado.....	603
Wisconsin.....	2,360	1,010	Indian Ter....	275
Minnesota.....	1,950	157	Arkansas.....	700	38
Iowa.....	3,728	805	Texas.....	1,578	451
Kansas.....	2,100	40			
Nebraska.....	1,107		Total.....	36,189	12,986
Missouri.....	2,858	925			

At the close of 1873 the total capital investment in all the railroads of the United States was \$3,784,543,034, represented by share capital to the amount of \$1,947,638,584, and bonded debts to the amount of \$1,836,904,450. This vast aggregate represented also the cost of the 70,651 miles of railroad then in operation, the average cost per mile for the whole country at that time equalling \$60,057. In New

England the average cost was \$47,850 per mile; in the Middle States, \$67,737 per mile; in the Western States, \$52,125 per mile; in the Southern States, \$36,994 per mile, and in the Pacific States, \$95,590 per mile. The maximum cost per mile was in New Jersey, where it averaged \$115,829; the minimum was in Florida, where the average was only \$18,445 per mile.

Table II. shows by groups of States, for 1873, the number of inhabitants to one mile of railroad; the number of square miles of territory to one mile of railroad; the amount of gross earnings of railroad per inhabitant and per mile of road; the percentage of gross earnings to cost; the percentage of net earnings to cost; and the percentage of dividend payments to capital stock.

The increase of mileage from 1871 to 1873 had been 21,623 miles, and the increase of the cost of the roads \$1,119,915,389. One cause for the excessive mileage built within a few years was the extraordinary effort to complete roads, in order to save from lapsing the vast grants made by Congress, on condition that the roads should be built within a certain time. But the increase was far beyond the possibility of speedy returns for the capital invested. That much land could be found unoccupied near the line of a railroad implied a sparse population, and although prairie soil could quickly be brought into cultivation, it would be long before there could be sufficient traffic to pay the interest on other cost of the roads. Excessive competition and speculation in railroad building and railroad bonds and stocks ensued until, in September, 1873, the great financial storm which has since passed into history as the "panic of 1873," burst upon the country. On the 20th of that month the New York Stock Exchange was closed by order of the Executive Committee, so great was the excitement, and was not opened again until the end of November. During the period of excessive speculation through which the country had passed, schemes of the most impossible or improbable kind had been freely floated, and it appeared as though the majority of people had virtually parted with all discretion.

Fifth Period.—After this fitful fever had culminated in the panic, the building of railroads fell off for two years, but in 1876 there was an evident recovery of tone. The second period of depression may be considered as lasting from 1873 to 1879. In 1873 the total mileage of lines constructed in the United States was 4097 miles. In the next year the total was only 2117 miles; in 1875 it fell off to 1711 miles; in 1876 there were built 2712 miles; in 1877, 2280, and in 1878, 2629 miles, the total during these five years being 11,449 miles, an average of only 2290 miles.

Sixth Period.—During 1879 matters began to improve throughout the country, and this feeling soon became reflected through the railroads. In that year construction increased nearly 100 per cent. over the preceding year.

The following statement shows the total mileage of railroads in operation at the close of each year from 1874 to 1887, with the annual increase in mileage:

Year.	Miles operated.	Increase.	Year.	Miles operated.	Increase.
1874.....	72,385	2,117	1881.....	103,145	9,796
1875.....	74,096	1,711	1882.....	114,713	11,568
1876.....	76,808	2,712	1883.....	121,454	6,741
1877.....	79,038	2,280	1884.....	125,379	3,825
1878.....	81,717	2,629	1885.....	128,987	3,608
1879.....	86,463	4,746	1886.....	137,986	9,000
1880.....	93,349	6,876	1887.....	149,913	11,927

During these 14 years there were built 79,645 miles of new railroad, an increase of over 112 per cent.; that is, in the last fourteen years we built 9400 miles of railroad more than we built in the preceding 44 years. The first five of these fourteen years comprised what we have termed the second period of depression; the

TABLE II.—*Ratios of Railroads and Railroad Earnings in 1873.*

	New England States.	Middle States.	Western States.	Southern States.	Pacific States.	Total United States.
No. of inhabitants to one mile of railroad.....	685	772	406	735	389	563
No. square miles of territory to one mile of railroad.	12.9	9.9	30.7	51.4	209.0	35.3
Gross earnings of railroad per inhabitant.....	\$14.50	\$18.00	\$14.49	\$ 4.76	\$23.68	\$12.80
Gross earnings per mile of railroad.....	\$9,687.00	\$12,417.00	\$6,421.00	\$3,687.00	\$9,477.00	\$7,947.00
Percentage of gross earnings to cost of railroad.....	19.7	22.5	11.8	10.7	9.9	13.1
Percentage of net earnings to cost of railroad.....	3.35	3.59	3.42	3.38	5.60	3.49
Percentage of dividend payments to capital stock..	6.36	5.00	2.25	0.40	2.00	3.45

next four years were years of unexampled activity; while the three years of 1883, 1884, and 1885 were years of hesitancy, in which no new railroad enterprise of great magnitude was begun, as was natural after the completion in a single year (1882) of 11,568 miles of road. The last two years, 1886 and 1887, which close the record, are memorable for the reason that within that time there was constructed a greater extent of mileage than in any two preceding years. In 1886 there were built 8343 miles, and in 1887, 13,188 miles, the latter surpassing the record of any previous year. In the two years the new construction aggregated 21,531 miles.

Since the revival of railroad construction in 1879 there have been completed three additional through transcontinental railroads, the Northern Pacific, the Atlantic and Pacific, and the Southern Pacific, while the Union Pacific, by the construction of its Oregon Short line northwest to a connection with a branch of the Oregon Railway and Navigation Company's system, has added another route to the Pacific. At least three of the great western railroad systems are also stretching westward, with the evident intention of speedily reaching the same ocean.

A striking feature of the last decade of railroad building is the large number of speculative and parallel lines which were put under way and many of them completed, notably the West Shore Railroad, which parallels the New York Central line for its whole length from New York to Buffalo; the "Nickel-Plate" line, which parallels Lake Shore in like manner from Buffalo to Chicago, and the South Pennsylvania paralleling the Pennsylvania Railroad between Philadelphia and Pittsburg, upon which a vast sum was expended, but which has not been completed. In some instances such lines were perhaps undertaken with a view to forcing their subsequent purchase by the older companies whose lines they sought to parallel, and in the case of the two roads first mentioned these plans met with eminent success. But their fulfillment was in the main the cause of the depression which existed during the years 1885, 1886, and 1887.

Railroad construction in the United States practically dates from 1828, when the Baltimore and Ohio Railroad was commenced. In 1830 there were but twenty-three miles of railroad in the whole country. The wonderful growth of this element of modern civilization since that time is shown in Table I., which gives by States and groups of States, quinquennially from 1835 to 1885, and for the last two years, 1886 and 1887, the mileage of all railroads in the United States.

RAILROAD LEGISLATION.

The railroad lines first constructed were all built under special charters granted by their respective State Legislatures. As the ramifications of the system became more extended and its advantages became more thoroughly appreciated by the public, the public was only too eager to encourage its further extension in every way possible. To this end it was deemed advisable to remove all obstacles or legislation that tended to hinder or obstruct the more speedy formation and inauguration of new railroad enterprises. In this work the State of New York led

by enacting in 1850 a General Railroad Law which provided for the organization of railroad corporations at will by 25 or more persons, without application to the Legislature, the object sought to be attained being unrestricted competition in railroads, as well as to relieve the Legislature of much labor. This law served as a model for all similar laws introduced since then in the other States of the Union.

The State railroad commissions, which are to-day a recognized factor in railway administration, have come into existence and prominence since 1867, although there were so-called commissions at an earlier period.

In some of the New England States at an early period in the history of railroads such commissions were established. New Hampshire led in 1844 with a single head commission. Connecticut and Vermont followed with similar commissions, 1853 and 1855 respectively. The powers of these boards were very limited and for the most part advisory. New York had a short-lived commission in 1855, and after the civil war several were created for a temporary purpose, distinct from regulation, such as that in Arkansas, which passed upon applications for State aid to railroads, and that in Tennessee, in 1870, which was authorized to sell or lease railroads in default to the State for loans. There are marked differences in the plan upon which the existing State commissions are organized. Of the older ones, those of the New England States, with the exception of Massachusetts and New Hampshire, form a distinct class by themselves, their duties being mainly limited to the inspection of the railway equipment and service.

Of an entirely different type were the commissions of the Western States, which owed their origin to the widespread "granger" movement (1870-77). Of this movement, Prof. Arthur T. Hadley writes in his work on *Railroad Transportation*:

"Nowhere had the policy of railroad subsidies been more recklessly carried out than in the Upper Mississippi Valley. The spirit of enterprise at the close of the war found full play here. There was no lack either of national land-grants or municipal subscriptions. Each community wanted railroads at any price. Each railroad offered glowing inducements to settlers. The result was that railroads and settlers both moved too far west; and ran heavily into debt to do it.

"In the years 1865-71, five hundred million dollars had been invested in Western railroads. These roads were dependent upon the wheat crop for their revenue. The price of wheat, which for some years had been high, was at last affected by the extension of production and the change of conditions. With transportation charges at their previous figure, the farmers could no longer pay their debts. With transportation charges reduced, the railroads could not pay theirs. There was a loss to be divided, instead of a profit. It was beyond the power of any law to divide this loss in such a way as to give a profit to both parties. It was the result of general industrial conditions.

"Unfortunately the railroads were managed in such a way that it seemed as if they were directly responsible for pretty much all these evils. In the first place they were run recklessly, with a most short-sighted view to present interests only. Outrageous favors were given in the way of special rates. Where there was but one railroad it charged all that it could extort. When the farmer had once settled so far from any market, he was at the mercy of the railroad, which furnished his sole means of transportation.

Table III. shows the area, population, and railroad mileage in the several States, and their relation each to the other on Jan. 1, 1887 :

TABLE III.—Area, Population, and Railroad Mileage, 1887.

States.	Area square miles.	Population.		Miles of railroad.	One mile of railroad	
		Total.	Per sq. mile.		To sq. miles.	To inhabitants.
Maine.....	33,040	648,936	19.64	1,149.51	28.73	564.62
New Hampshire.....	9,305	346,991	37.29	1,050.17	8.86	330.41
Vermont.....	9,565	332,286	34.74	946.75	10.10	350.98
Massachusetts.....	8,315	1,783,085	146.03	2,018.46	4.12	883.39
Rhode Island.....	1,250	276,531	221.22	209.99	5.95	1,316.81
Connecticut.....	4,900	622,700	127.08	975.56	5.02	638.30
New England Group.....	66,375	4,010,329	60.42	6,350.44	10.45	631.57
New York.....	49,170	5,082,871	103.37	7,481.40	6.57	679.40
New Jersey.....	7,815	1,131,116	144.74	1,957.41	3.99	577.86
Pennsylvania.....	45,215	4,282,891	94.72	7,871.56	5.74	544.09
Delaware.....	2,050	146,608	71.50	334.50	6.31	438.29
Maryland.....	12,210	934,943	76.57	1,225.09	3.18	755.00
District of Columbia.....	70	177,624	76.57	21.61	9.97	8,219.53
Middle Atlantic Group.....	116,530	11,756,053	100.88	18,891.57	6.17	622.30
Ohio.....	41,060	3,198,062	77.89	7,456.18	5.51	423.91
Michigan.....	58,915	1,636,937	27.78	5,635.82	10.45	290.45
Indiana.....	36,350	1,978,301	54.42	5,711.19	6.37	346.39
Illinois.....	56,650	3,077,871	54.33	9,275.69	6.11	331.82
Wisconsin.....	56,040	1,315,497	23.47	4,860.17	11.51	270.17
North Central Group.....	249,015	11,206,668	45.01	32,948.05	7.56	340.12
Virginia.....	42,450	1,512,565	35.63	2,729.83	15.55	544.09
West Virginia.....	24,780	618,457	24.96	1,146.82	21.60	539.28
North Carolina.....	52,250	1,399,750	26.78	2,201.60	23.73	635.79
South Carolina.....	30,570	995,577	32.57	1,813.60	16.85	548.85
Georgia.....	59,475	1,542,180	25.93	3,390.59	17.54	454.85
Florida.....	58,680	269,493	4.59	1,918.18	30.69	140.49
South Atlantic Group.....	268,205	6,338,022	23.63	13,200.53	20.31	480.15
Kentucky.....	40,400	1,648,690	40.81	2,116.78	19.08	778.91
Tennessee.....	42,050	1,542,359	36.68	2,199.10	19.12	701.36
Alabama.....	52,250	1,262,505	24.16	2,280.46	22.91	557.62
Mississippi.....	46,810	1,131,597	24.17	2,111.38	22.17	537.95
Louisiana.....	48,720	939,946	19.29	1,381.16	35.28	680.55
South Central Group.....	230,230	6,525,097	27.04	10,088.88	22.82	646.80
Missouri.....	69,415	2,168,380	31.24	5,068.32	13.69	427.83
Arkansas.....	53,850	802,525	14.90	2,195.68	24.52	365.50
Indian Territory.....	61,690	431.87	149.75
Texas.....	265,780	1,591,749	5.99	7,295.27	36.43	218.19
Kansas.....	82,080	996,096	12.14	6,119.40	13.41	162.77
Colorado.....	103,925	194,327	1.87	2,943.56	35.30	66.02
New Mexico.....	122,580	119,565	0.98	1,232.96	99.42	96.97
South-Western Group.....	762,320	5,872,642	8.42	25,287.06	30.15	232.23
Iowa.....	56,025	1,624,615	29.00	7,934.80	7.06	205.12
Minnesota.....	83,365	780,773	9.37	4,823.11	17.28	161.88
Nebraska.....	76,855	452,402	5.88	3,615.89	21.25	125.11
Dakota.....	149,100	135,177	0.97	3,698.21	40.32	36.55
Wyoming.....	97,890	20,789	0.21	777.72	125.82	26.73
Montana.....	146,080	39,159	0.27	1,062.48	137.55	36.86
North-Western Group.....	609,315	3,052,915	5.01	21,912.21	27.81	139.78
Washington Territory.....	69,180	75,116	1.09	897.90	77.04	83.66
Idaho.....	84,800	32,610	1.82	811.28	78.78	40.19
Oregon.....	96,030	174,768	5.46	1,219.41	48.03	143.16
California.....	158,360	864,094	0.56	3,296.76	116.04	262.29
Nevada.....	110,700	62,266	0.36	954.18	114.28	65.26
Arizona.....	113,020	40,440	1.69	988.95	74.60	49.89
Utah.....	84,970	143,963	0.38	1,138.97	104.56	126.39
Pacific Group.....	717,060	1,393,857	1.94	9,307.45	77.05	149.76
United States.....	3,019,050	50,155,783	16.98	137,986.19	21.89	363.49

"A state of feeling was developed through the community which only wanted organization to become all powerful. It found this organization in the Granges. (See GRANGES.)

"That the movement against the railroads should come, was inevitable. That it took this particular instrument to make itself felt was in some sense an accident. When the first Granges were formed, the purposes of the organization were, first, to render farmers' homes attractive, and, second, to make farming more productive. As a means to this second end they sought to diminish the expenses; and one of the most important elements of expense was the cost of getting goods to market. It was thus that they became interested, as an organization, in questions of transportation and of railroad control. Their first utterances on this matter were moderate; it was but gradually that they became the instrument of popular agitation.

"The first tangible results were reached in Illinois. The constitutional convention of 1870 made an important declaration concerning State control of rates, on the basis of which a law was passed in 1871, establishing a system of maxima. This law was pronounced unconstitutional by Judge Lawrence. The result was that he immediately afterward failed of re-election, solely on this ground. The defeat of Judge Lawrence showed the true significance of the farmers' movement. They were concerned in securing what they felt to be their rights, and they were unwilling that any constitutional barriers should be made to defeat the popular will. They had reached the point where they regarded many of the forms of law as mere technicalities. They were dangerously near the point where revolutions begin.

"But they did not pass the point. The law of 1873 avoided the issue raised by Judge Lawrence against that of 1871. Instead of directly fixing maxima, it provided that rates must be reasonable, and then further provided for a commission to fix reasonable rates. Similar laws were passed by Iowa and Minnesota almost immediately afterward. The Legislature of Wisconsin went even farther, fixing by the so-called Potter Law the rates on different classes of roads at figures which proved quite unremunerative. The railroads made vain attempts to contest these regulations in the courts. They were defeated again and again, and finally, in 1877, the Supreme Court of the United States sustained the constitutionality of the Granger laws.

"But a more powerful force than the authority of the court was working against the Granger system of regulation. The laws of trade could not be violated with impunity. The effects were most sharply felt in Wisconsin. The law reducing railroad rates to the basis which competitive points enjoyed left nothing to pay fixed charges. In the second year of its operation no Wisconsin road paid a dividend; only four paid interest on their bonds. Railroad construction had come to a standstill. Even the facilities on existing roads could not be kept up. Foreign capital refused to invest in Wisconsin; the development of the State was sharply checked; the very men who had most favored the law found themselves heavy losers. These points were plain to every one. They formed the theme of the governor's message at the beginning of 1876. The very men who passed the law in 1874 hurriedly repealed it after two years' trial. In other States the laws either were repealed, as in Iowa, or were sparingly and cautiously enforced. By the time the Supreme Court published the Granger decisions, the fight had been settled, not by constitutional limitations but by industrial ones."

The first of the State commissions to attract public attention was that of Ohio, which was established in 1867, Gen. George B. Wright being the first incumbent of the office. Gen. Wright being a practical railroad man, his investigations and reports on matters of practical importance and public interest received considerable attention from all interested in the problem of governmental supervision or control of railroads.

The Massachusetts railroad commission was established in 1869, and furnishes the most conspicuous instance of the purely advisory commission, depending upon investigation, the justice of its conclusions, and the force of public opinion for the enforcement of its recommendations; and by reason of its successful working under a novel plan and of the ability of its membership it has always made its influence widely felt. Since its establishment its career has been closely watched, and its success is now undisputed. That it has not been due solely to fortuitous circumstances, or

to its application to a limited local field, is indicated by the fact that the principle upon which it was organized has been successfully applied in other States and has been followed by satisfactory results in the State of New York, with its concentration of great and diverse railroad and commercial interests.

The Illinois commission has been the leading exponent of the other theory of regulation through a commission. It was inaugurated by the adoption of the constitution of 1870, now in force, which declared railways to be public highways, and free to all persons for the transportation of their persons and property thereon, under such regulations as may be prescribed by law. The General Assembly is required to pass laws establishing reasonable maximum rates of charges for the transportation of passengers and freight; to correct abuses and prevent unjust discrimination and extortion; and to enforce such laws by adequate penalties to the extent, if necessary for that purpose, of forfeiture of the property and franchise of the railways. The consolidation of railroad companies owning parallel or competing lines is prohibited, and sixty days' public notice of all proposed consolidations is required.

The railroad legislation of the Southern States has in the main followed the general features of the Georgia system, which is similar to that of Illinois. The constitution gives the General Assembly power to regulate railroad freight and passenger tariffs, prevent unjust discriminations, and require reasonable rates, and it is made its duty to pass laws for these purposes and to enforce the same by adequate penalties. The General Assembly is prohibited from authorizing any corporation to buy shares or stock in any other corporation in the State or elsewhere, or to make any contract or agreement with any such corporation which may have the effect to defeat or lessen competition in their respective businesses, or to encourage monopoly; and all such contracts are declared illegal and void. Railroad companies are prohibited from giving or paying any rebate, or bonus in the nature thereof, directly or indirectly; or doing any act to deceive the public as to the real rates received. Such payments are declared illegal and void, and the General Assembly is required to enforce these prohibitions by suitable penalties.

California is the only State which has adopted the commission system as a part of the organic law of the State. The constitution of 1879 is extremely rigid in its provisions for the regulation of railroads. It declares all railroad, canal, and transportation companies common carriers and subject to legislative control, and requires railroads to receive and transport each other's passengers, tonnage, and cars without delay and discrimination.

The following statement shows the States having commissions and the year in which commissions were first established in each State, arranged in the order of their establishment:

State.	Date.	State.	Date.
New Hampshire.....	1844	Virginia	1876
Connecticut.....	1853	Iowa	1878
Vermont.....	1855	South Carolina.....	1878
Maine.....	1858	Georgia.....	1879
Ohio.....	1867	Kentucky	1880
Massachusetts	1869	Alabama	1881
Illinois.....	1871	New York	1882
Rhode Island.....	1872	Kansas	1883
Michigan.....	1873	Mississippi.....	1884
Wisconsin.....	1874	Nebraska.....	1885
Minnesota.....	1874	Colorado.....	1885
Missouri.....	1875	Dakota.....	1885
California	1876		

Interstate Commerce Commission.--This commission, the first tribunal organized in connection with the National government, and clothed with advisory and other powers to regulate the traffic of railroads, began its official labors April 5, 1887. The assumption of

these powers by the National government had been zealously advocated for many years by a large and influential class of citizens who held that under the provision of the Constitution investing Congress with power to regulate the commerce between the States, Congress possessed the right to regulate the traffic of railroads, or other agencies of transportation, between the States. This proposition was, however, strenuously opposed by those who held contrary views as to the proper functions of the National government.

As far back as December, 1872, the Senate of the United States, upon the recommendation contained in Pres. Grant's message, appointed a committee to consider the question of transportation routes to the seaboard and to report to Congress with a view to "its better guidance in legislating on this important subject." In the preamble to the resolution authorizing the appointment of this committee it was recited that "the productions of our country have increased much more rapidly than the means of transportation, and the growth of population and products will in the near future demand additional facilities, and cheaper ones, to reach tide-water." The committee began its investigation in September, 1873, and pursued its inquiries in various parts of the country until the close of the year. A great mass of testimony was elicited upon all subjects examined, particularly those affecting the question of railroad transportation; but nothing tangible resulted from its deliberations or conclusions, at least so far as concerned the assumption of any controlling powers by Congress. The question of Congressional regulations of interstate commerce, however, continued to be discussed and agitated with more or less vigor, particularly during the three years immediately preceding the final passage of the Interstate Commerce Act.

As a result of the active interest that was being exhibited throughout the country upon this subject, particularly in the West, the U. S. Senate in March, 1885, appointed a committee "to investigate and report upon the subject of the regulation of the transportation by railroad and water routes in connection or in competition with said railroads of freights and passengers between the several States." From its chairman, Senator Shelby M. Cullom, of Illinois, the committee became popularly known as the Cullom Committee; and the bill presented by it subsequent to its extended investigations is known as the Cullom Interstate Commerce Bill. This bill was reported from a conference committee of both Houses Dec. 15, 1886, and was passed and became operative April 5, 1887. A brief synopsis of the bill is appended: By section 1 the railroads and other transportation companies are

required to have just and reasonable rates; section 2 forbids discriminations by special rates, rebates, drawbacks, etc.; section 3 forbids undue preferences to individuals or localities, and requires that carriers shall provide facilities for interchange of traffic; section 4 requires a uniform rate for all distances, but in special cases the commission may suspend this rule; section 5 forbids pooling of freights and division of earnings between carriers; section 6 requires schedules of rates, charges, and fares to be printed and copies kept at every station for public use, and forbids any increase in the rates so published without due notice; section 7 forbids acts interfering with and contracts preventive of continuous carriage of freight; section 8 makes the common carrier liable to the person injured for any damages sustained through any act done or permitted by the carrier contrary to this law; section 9 gives the person damaged the right to make complaint to the commission or to bring action in his own behalf, but forbids him the right to pursue both remedies, and in any such action brought the court is empowered to compel officers of companies to attend, testify, and produce books and papers; section 10 imposes a penalty for disobedience or infraction of the act; section 11 creates the Interstate Commerce Commission, and makes rules for its guidance; section 12 authorizes the commission to inquire into the management of the business of all common carriers, and to require attendance of witnesses and production of books, contracts, and documents relating to any matter under investigation; section 13 and those following make provision for the investigation of complaints, etc.

Pres. Cleveland appointed a commission of the highest character, Hon. Thomas M. Cooley, who had been chief-justice of Michigan, being chairman. The commission entered upon its important duties in a cautious and judicial spirit, which has been highly approved by all parties concerned in the questions submitted to it. Its labors have proved highly beneficial to the country, and will undoubtedly result in wise regulations, both by the National and State governments and by the railroad companies themselves.

The chief aim of the commission has been to secure on behalf of the people fixed and uniform charges for railroad service. The railroad corporations now admit that their own interest, and the interest of all who have invested in this species of property, will be subserved by effecting this.

RAILROAD OPERATION AND EARNINGS.

Table IV. shows the length of line operated, rev-

TABLE IV.—*Railroad Operation and Earnings in the United States.*

	1882.	1883.	1884.	1885.	1886.	1887.
Miles of Line Operated...	98,752.33	106,938.49	113,172.66	122,110.16	125,146.50	136,986.49
<i>Revenue Train Mileage:</i>						
Passenger.....	165,438,158	187,903,247	206,516,118	211,587,620	210,637,892	238,755,920
Freight.....	305,118,035	350,108,255	334,814,529	342,288,770	349,697,537	394,191,107
Mixed.....				6,297,575	9,437,561	11,031,869
Total.....	470,556,193	538,011,502	541,330,647	560,173,965	569,772,990	643,978,896
<i>Passenger Traffic:</i>						
Passengers carried.....	289,030,783	312,686,641	334,570,766	351,427,688	382,284,972	428,225,513
Passenger Miles.....	6,983,059,934	8,541,309,674	8,778,581,061	9,133,673,956	9,659,698,294	10,570,306,710
<i>Freight Traffic:</i>						
Freight moved (Tons).....	360,490,375	400,453,439	399,074,749	437,010,099	482,215,254	552,074,752
Freight Miles (Tons).....	39,302,209,249	44,064,923,445	44,725,207,677	49,151,894,469	52,802,070,529	62,061,069,996
<i>Gross Traffic Earnings:</i>						
From Passenger.....	\$194,060,159	\$206,837,256	\$206,790,701	\$200,883,911	\$212,929,857	\$240,512,876
From Freight.....	485,778,331	539,509,831	502,869,910	509,690,992	550,359,054	636,666,223
Total, including Miscell..	733,960,943	807,112,780	763,306,608	765,310,419	822,191,949	931,385,154

TABLE V.—Mileage, Capitalization, and Cost.

Fiscal years.	Miles of railroad completed.	Capital stock.	Funded debt.	Other debt.	Total stock and debt.	Cost of railroad and equipment.	Miles of railroad operated.
1887.....	147,999	\$4,191,562,029	\$4,186,943,116	\$294,682,071	\$8,673,187,216	\$7,799,471,835	136,986
1886.....	133,606	3,999,508,508	3,882,966,330	280,673,814	8,163,148,652	7,254,995,223	125,147
1885.....	127,729	3,817,697,832	3,765,727,066	259,108,281	7,842,533,179	7,037,627,350	122,110
1884.....	125,152	3,762,616,686	3,669,115,772	244,666,596	7,676,399,054	6,924,554,444	113,173
1883.....	120,552	3,708,060,583	3,455,040,353	332,370,345	7,495,471,311	5,684,756,045	110,414
1880.....	92,147	2,708,673,375	2,530,874,943	162,499,939	5,402,038,257	4,653,609,297	82,147
1876.....	76,305	2,148,358,375	2,220,233,560	203,504,556	4,572,096,491	3,886,653,178	71,998

TABLE VI.—Railroad Earnings, Expenses, Interest, and Dividends.

Fiscal years.	Passenger earnings.	Freight earnings.	Total earnings.	Operating expenses.	Net earnings.	Interest payments.	Dividend payments.
1887.....	\$240,542,876	\$636,666,223	\$931,385,154	\$600,249,478	\$331,135,676	\$203,790,352	\$91,573,458
1886.....	212,929,857	550,359,054	822,191,949	524,880,334	297,311,615	189,036,304	80,094,138
1885.....	200,883,911	509,690,992	765,310,419	498,821,426	266,488,993	187,426,035	77,672,105
1884.....	208,300,940	502,925,375	763,306,608	496,792,697	266,513,911	176,694,302	93,244,835
1883.....	206,837,256	539,509,831	807,112,780	515,525,192	291,587,588	173,139,064	102,652,548
1880.....	147,653,003	467,748,928	613,733,610	341,302,945	272,430,665	107,866,328	77,115,371
1876.....	136,120,583	361,137,376	493,233,629	308,075,099	185,158,430	93,559,573	68,039,668

enue train mileage, passenger and freight traffic, and gross traffic earnings of all the railroads in the United States for six years, 1882-87, inclusive.

Tables V. and VI. show the length, capitalization, debt and cost of the railroads of the United States at the close of recent years; the average length of same operated during such years, and the earnings, expenses, interest and dividend payments thereof.

An examination of the statistics of capitalization and debt (see Table V.) shows the following averages per mile of railroad for the past six years:

Year.	Capital stock per mile.	Bonded debt per mile.	Cost of road per mile.
1887.....	\$28,321	\$28,290	\$52,699
1886.....	29,925	29,062	54,301
1885.....	29,867	29,453	55,059
1884.....	30,064	29,317	55,329
1883.....	30,759	28,650	55,461
1882.....	30,674	28,268	52,726

The steady decrease in the average cost of road and equipment per mile during the past five years is the most striking feature of this table. It is due largely to the fact that the new lines of railroad built within that period for the most part run through sections of the country which present no extraordinary engineering difficulties; and in no small degree to the wonderful improvements that have been made in the manner of constructing railroads—the great speed secured by the massing of veritable armies of workmen at various points of the road, and the extraordinary reduction in the cost of the chief articles that enter into the construction of such work.

A comparison of these statistics by the eight groups into which the country has been divided shows the following relative averages for 1887:

Groups.	Capital stock per mile.	Bonded debt per mile.	Cost of road per mile.
New England.....	\$33,801	\$20,931	\$52,613
Middle Atlantic.....	57,982	57,451	97,043
Central Northern.....	23,688	24,868	46,536
South Atlantic.....	19,888	19,911	36,014
South Central.....	23,739	27,640	48,809
South-western.....	23,470	22,594	43,429
North-western.....	22,368	25,485	48,125
Pacific.....	30,443	26,881	61,054

The following statement shows the relative earning capacity of the railroads in the several groups during 1887:

Groups.	Passenger earnings per mile.	Freight earnings per mile.	Gross earnings per mile.	Net earnings per mile.
New England.....	\$4,168	\$4,801	\$9,495	\$2,758
Middle Atlantic.....	3,373	9,696	13,560	5,067
Central Northern.....	1,563	4,509	6,479	2,284
South Atlantic.....	937	2,431	3,740	1,163
South Central.....	1,247	3,710	5,274	1,817
South-western.....	1,135	3,363	4,873	1,676
North-western.....	1,079	3,320	4,720	1,844
Pacific.....	1,699	3,820	6,205	2,455
Whole U. S., 1887.....	\$1,756	\$4,649	\$6,661	\$2,444
United States, 1886.....	1,693	4,397	6,570	2,376
" " 1885.....	1,612	4,219	6,265	2,185

During the past six years the relation of passenger earnings to freight earnings in the whole country has varied but slightly; passenger earnings usually averaging about 26 per cent. of gross earnings, while freight earnings have averaged about 67 per cent. Comparing the groups, however, wide differences are shown. In New England passenger and freight approach nearest to equality, the former being 43.89 per cent. of the gross, and the latter 50.56 per cent. The greatest disparity is in the North-western States and in the Middle States, the proportion for passenger earnings in the former case being 22.86 per cent. of gross as against 70.33 per cent. for freight earnings, while in the Middle States the respective percentages of passenger and freight earnings were 25.18 and 72.36. The following statement shows the relative proportions of passenger, of freight, and of miscellaneous earnings to gross traffic earnings in the several groups of the United States in 1887:

Groups.	Passenger earnings. Per cent.	Freight earnings. Per cent.	Other earnings. Per cent.
New England.....	43.89	50.56	5.55
Middle Atlantic.....	25.18	72.36	2.40
Central Northern.....	24.12	69.59	6.29
South Atlantic.....	25.06	65.01	9.93
South Central.....	23.65	70.34	6.01
South-western.....	23.29	69.02	7.69
North-western.....	22.86	70.33	6.81
Pacific.....	27.38	61.56	11.06
United States.....	25.82	68.38	5.80

In this connection the following statement of passenger traffic in the several groups of the country for 1887 and of the whole United States for the years 1883 to 1887 is instructive:

Groups.	Number of passen- gers carried.	Number car- ried one mile.
New England.....	93,483,949	1,482,312,733
Middle Atlantic.....	176,361,731	3,059,957,868
Central Northern.....	87,292,882	3,027,621,204
South Atlantic.....	11,315,150	396,245,486
South Central.....	11,379,600	438,688,840
South-western.....	18,421,275	923,887,906
North-western.....	13,502,021	614,419,651
Pacific.....	16,468,905	627,173,022
United States, 1887....	428,225,513	10,570,306,710
" " 1886....	382,284,972	9,659,698,294
" " 1885....	351,427,688	9,133,673,956
" " 1884....	334,570,766	8,778,581,061
" " 1883....	312,636,641	8,541,309,674

An examination and comparison of these figures show that in New England the average distance travelled by each passenger was less than in any other group, while the longest trips were made in the South-western States. In like manner the rates of fare averaged lowest in New England and highest in the South-west. This can be best illustrated by the following tabular statement showing the average distance travelled per passenger and the average rate of fare per mile for same in each group in 1887:

Groups.	Average distance per passenger.	Average rate per passenger per mile.
New England.....	15.85 miles.	1.984 cents.
Middle Atlantic.....	17.35 "	2.092 "
Central Northern.....	34.68 "	2.274 "
South Atlantic.....	35.01 "	2.777 "
South Central.....	38.55 "	2.421 "
South-western.....	50.15 "	2.824 "
North-western.....	45.50 "	2.692 "
Pacific.....	38.08 "	2.277 "

In the whole United States the average distance per passenger was 24.68 miles, and the average rate of fare per mile 2.276 cents. The tendency throughout the country in both these respects is toward decreases in the length of the average trip and in the rates charged. No better evidence of the constant and rapid growth of the country can be furnished than the statistics of the passenger traffic of its railroads. By the table of passenger traffic given above it is shown that within the short space of five years, from 1883 to 1887, the number of passengers using the railroads of the United States (excluding all elevated

and surface city roads) increased 115,538,872, or from 312,686,641 to 428,225,513. The rate of increase within this period of five years was 37 per cent. If an increase of 33½ per cent. in every five years were to be maintained for fifteen years longer we would have in 1902 a passenger traffic of more than 1,014,000,000 persons. The following statement shows the steady decline in the average rate of fare per mile in every year from 1882 to 1887 (except the latter year, in which a slight advance was recorded), and the corresponding decreases in the average distance per passenger per mile:

Years.	Average rate per passenger per mile.	Average distance per passenger.
1882.....	2.514 cents.	28.89 miles.
1883.....	2.422 "	27.32 "
1884.....	2.356 "	26.24 "
1885.....	2.198 "	25.99 "
1886.....	2.181 "	25.27 "
1887.....	2.276 "	24.68 "

The constant decrease in average distance is due to the increase in the number of passengers carried, which as a country becomes developed will inevitably reduce the average length of trip for all passengers.

While the country has been undergoing the wonderful and unprecedented material development witnessed in the past twenty-two years, the inventive genius of the country has been engaged in bringing to perfection the details of railroad construction. The result is shown in the solidity of railroad superstructure of to-day, its massive bridges and viaducts, its wonderful tunnels and other great works built to overcome nature's obstructions, in the improved cars and engines of to-day, and the consequent increase of comfort in railroad travel. It was to be expected, with all those forces operating simultaneously, that there would be a steady increase of use of the improved facilities, but the results have surpassed anticipations.

Table VII. shows the number of tons of freight moved each year, the earnings therefrom, the aggregate tonnage-mileage, and the average rate per ton per mile for all roads, yearly, from 1865 to 1887, inclusive, on the Illinois Central, the Chicago and Alton, the Chicago and Rock Island, the Chicago, Burlington, and Quincy, the Chicago and North-western, the Chicago, Milwaukee, and St. Paul Railroads, with the aggregate tons moved annually on the same:

TABLE VII.—Freight Business of Six Principal Western Railroads since 1865.

Year.	Aggregate tonnage moved.	Aggregate of earnings.	Aggregate for each year.	Rate charge per ton per mile.
	Tons.	Dollars.	Tons-Miles.	Cents.
1865.....	4,032,166	18,703,805	513,421,459	3.642
1866.....	4,803,205	19,957,327	576,888,638	3.459
1867.....	6,303,783	24,389,631	768,171,050	3.175
1868.....	7,064,305	28,198,440	893,856,974	3.151
1869.....	8,071,568	31,911,794	1,054,559,835	3.026
1870.....	8,540,579	29,919,958	1,234,678,291	2.423
1871.....	9,391,684	30,947,254	1,233,058,058	2.509
1872.....	10,592,414	21,074,669	1,337,038,063	2.324
1873.....	11,958,467	37,629,776	1,719,496,690	2.188
1874.....	12,637,729	40,004,035	1,851,645,825	2.160
1875.....	12,662,768	37,699,553	1,904,937,377	1.979
1876.....	13,488,204	37,449,705	1,994,712,255	1.877
1877.....	13,364,721	36,799,051	2,211,021,475	1.664
1878.....	15,705,226	41,666,157	2,822,885,886	1.476
1879.....	18,807,123	44,410,617	3,470,822,877	1.279
1880.....	24,212,307	57,551,693	4,167,610,830	1.389
1881.....	27,076,047	63,007,765	4,498,641,431	1.405
1882.....	29,851,868	68,792,350	5,040,239,952	1.364
1883.....	31,663,979	75,565,194	5,768,109,279	1.310
1884.....	32,573,518	74,355,296	6,093,282,749	1.220
1885.....	34,348,684	75,307,684	6,500,185,261	1.158
1886.....	35,690,547	75,667,342	6,806,148,918	1.111
1887.....	40,276,909	78,890,235	7,776,436,486	1.014

Table VIII. shows the aggregate number of tons of freight moved, the aggregate freight earnings, and the aggregate tonnage-mileage, yearly, from 1865 to 1887, inclusive, on the Pennsylvania, the Pittsburg, Fort Wayne, and Chicago, the New York Central, the Lake Shore, the Michigan Central, the Boston and Albany, the New York, Lake Erie, and Western Railroads, with the average rate per ton per mile on all the roads:

TABLE VIII.—*Freight Business of Seven Principal Eastern Railroads since 1865.*

Year.	Aggregate tonnage moved.	Aggregate of earnings.	Aggregate for each year.	Rate-charge per ton per mile.
	Tons.	Dollars.	Tons-Miles.	Cents.
1865.....	11,151,700	47,832,803	1,649,316,859	2.900
1866.....	14,049,602	51,876,744	2,044,416,231	2.503
1867.....	15,594,454	52,074,335	2,258,216,174	2.305
1868.....	17,468,693	54,189,263	2,541,578,620	2.132
1869.....	20,556,154	58,826,156	3,159,832,219	1.860
1870.....	21,456,135	58,732,642	3,685,824,803	1.593
1871.....	25,098,953	64,168,533	4,340,131,068	1.478
1872.....	28,634,347	76,469,165	5,081,263,127	1.504
1873.....	32,817,277	85,100,099	5,762,022,724	1.476
1874.....	32,899,152	73,320,227	5,879,662,649	1.332
1875.....	32,956,655	68,919,790	5,935,242,897	1.161
1876.....	36,166,865	66,395,282	6,739,527,502	.985
1877.....	36,133,676	63,509,865	6,536,997,523	.971
1878.....	39,124,614	70,581,816	7,855,222,593	.898
1879.....	48,585,226	73,383,367	9,594,719,603	.706
1880.....	53,937,403	88,792,026	10,313,056,759	.869
1881.....	62,616,114	88,210,592	11,560,001,888	.763
1882.....	64,948,002	84,606,002	11,191,066,104	.761
1883.....	66,695,608	93,913,066	11,326,271,886	.825
1884.....	64,397,566	79,401,737	10,719,521,813	.740
1885.....	66,521,153	72,138,792	11,331,309,298	.636
1886.....	74,517,207	84,761,134	11,915,435,513	.711
1887.....	84,754,598	97,357,011	13,543,351,451	.718

Table IX. shows the number of locomotive-engines, cars in the United States for the years 1877-87, inclusive: passenger-, baggage-, mail- and express-, and freight-

TABLE IX.—*Rolling Stock of Railroads in the United States.*

Year.	Locomotive engines.	Revenue cars.			
		Passenger.	Baggage, mail, and express.	Freight.	Total.
1877.....	15,911	12,053	3,854	392,175	408,082
1878.....	16,445	11,683	4,413	423,013	439,109
1879.....	17,084	12,009	4,519	480,190	496,718
1880.....	17,949	12,789	4,786	539,255	556,930
1881.....	20,116	14,548	4,976	648,295	667,819
1882.....	22,114	15,551	5,566	730,451	751,568
1883.....	23,623	16,889	5,843	778,663	801,400
1884.....	24,587	17,303	5,911	798,399	821,613
1885.....	25,937	17,290	6,044	805,519	828,853
1886.....	26,415	19,252	6,325	845,914	871,491
1887.....	27,850	20,582	6,582	956,631	983,805

Table X. shows the number of miles of steel the total track in the United States, for the years rails and iron rails, also the percentage of steel rails to 1880-87 inclusive:

TABLE X.—*Steel and Iron Rails in the United States.*

Year.	Miles steel rails.	Miles Iron rails.	Total miles.	Per cent. steel of total.
1880.....	33,680	81,967	115,647	29.1
1881.....	49,063	81,473	130,536	37.5
1882.....	66,691	74,269	140,960	47.3
1883.....	78,491	70,692	149,183	52.7
1884.....	90,243	66,254	156,497	57.6
1885.....	98,102	62,495	160,597	61.0
1886.....	105,724	62,324	168,048	62.9
1887.....	128,959	60,388	189,347	68.1

Table XI. shows the relative proportions, for two years, of dividend-paying and non dividend-paying capital stock.

TABLE XI.—Comparison of Railroad Capital and Dividends.

	New England.		Middle Atlantic.		North Central.		South Atlantic.	
	1882.	1886.	1882.	1886.	1882.	1886.	1882.	1886.
Total capital stock.....	\$197,071,108	\$302,673,477	\$657,064,000	\$1,035,526,998	\$932,591,770	\$1,054,897,889	\$196,178,025	\$249,981,335
Amount dividend-paying.....	137,430,066	161,747,912	570,056,765	564,555,710	462,650,427	461,248,593	60,741,814	40,927,666
Amount not paying dividends.....	59,641,042	40,925,565	387,008,135	470,971,288	469,941,343	593,649,296	135,436,211	208,053,669
Total amount paid in dividends.....	8,707,540	9,483,360	36,777,072	27,731,093	\$1,294,552	27,124,794	3,109,247	2,216,146
Percentage on total capital.....	4.42	4.66	3.84	2.66	8.35	2.57	1.59	.89
Percentage on dividend-paying.....	6.34	5.66	6.45	4.91	6.76	5.10	5.10	4.73
Percentage of capital stock producing dividends.....	69.74	79.81	89.56	54.53	49.61	43.72	30.96	18.77
Percentage of capital stock not producing dividends.....	30.26	20.19	40.44	45.47	50.39	56.28	69.04	81.23

TABLE XI.—Continued.

	South Central.		South-western.		North-western.		Pacific.	
	1882.	1886.	1882.	1886.	1882.	1886.	1882.	1886.
Total capital stock.....	\$180,689,130	\$246,484,940	\$486,942,449	\$621,137,639	\$397,058,263	\$321,517,223	\$231,365,601	\$266,144,597
Amount dividend-paying.....	40,544,045	15,711,582	159,431,980	169,947,607	139,076,062	71,847,038	103,859,700	183,683,636
Amount not paying dividends.....	140,145,085	230,773,358	327,510,469	451,190,032	157,982,201	252,670,185	127,505,901	82,461,361
Total amount paid in dividends.....	1,232,737	601,595	7,244,192	8,090,406	7,475,981	2,907,004	6,126,239	1,939,740
Percentage on total capital.....	.68	.25	1.69	1.33	2.52	.73	2.11	.73
Percentage on dividend-paying.....	3.04	3.83	4.55	4.05	5.37	4.05	5.90	1.05
Percentage of capital stock producing dividends.....	22.44	6.37	32.74	27.36	46.85	22.14	55.11	69.02
Percentage of capital stock not producing dividends.....	77.56	93.63	67.26	72.64	53.15	77.86	44.89	30.98

During the six years in which full statistics of passenger and freight traffic of all the railroads in the United States have been compiled the increase in freight business has kept pace and in some years has largely exceeded the increase in passenger movement.

In the following statement the statistics of freight tonnage, tonnage mileage (tons carried one mile), average haul per ton, and average rates received per ton per mile on all the railroads of the United States are shown for the six years from 1882 to 1887 inclusive:

TABLE XII.—*Freight Movement.*

Years.	Freight moved.	Freight movement.	Average haul per ton.	Average rate per ton per mile.
	Tons.	Miles.	Miles.	Cents.
1882.....	360,490,375	39,302,209,249	109.02	1.236
1883.....	400,453,439	44,064,923,445	110.04	1.236
1884.....	399,074,749	44,725,207,677	112.07	1.124
1885.....	437,040,099	49,151,894,469	112.46	1.057
1886.....	482,245,254	52,802,070,529	109.49	1.042
1887.....	552,074,752	62,061,069,996	108.79	1.063

As these figures show there was an increase in number of tons of freight moved in 1887 over 1882 of 191,584,377 or 53.14 per cent., against an increase in number of passengers carried of 139,194,730 or 48.16 per cent. In the aggregate movement of each the following showing is made: Number of passengers carried one mile in 1882, 7,483,059,934; in 1887, 10,570,306,710; increase, 3,087,246,776, or 41.25 per cent. Number of tons of freight moved one mile in 1882, 39,302,209,249; in 1887, 62,061,069,996; increase, 22,758,860,747 tons or 57.90 per cent.

These enormous increases were directly the result of the rapid extension of the railroad system of the country which opened up to settlement and commerce immense tracts of land whose products were previously comparatively valueless through their inaccessibility to the markets of the country.

The remarkably rapid and steady decline of freight rates is shown in Table XII., and more fully in VII. and VIII. The fast two show that east of Chicago freight rates have declined from 2.9 cents per ton per mile in 1865 to 0.718 cent in 1887; while west of Chicago the decline has been from 3.642 cents in 1865 to 1.014 cents in 1887. Unquestionably these results could not have been attained otherwise than by the many improvements in construction methods already mentioned.

Rails.—One of the most important items that enters into the cost of a railroad is the rails used. The style of rails used on the first lines built in the country have already been described and reference has been made already to the gradual substitution of heavy rails, which, after 1850, came into general use. The first T rails rolled in this country were rolled in October, 1845, at the Montour rolling-mill, Danville, Pa., which was built in that year. The invention of the Bessemer steel process dates from 1855. The first steel rails used in this country were imported from England by the Pennsylvania Railroad. The first experimental rails rolled in this country were made at the North Chicago rolling-mill from steel made at Wyandotte, Mich., on May 24, 1865. It was not until August, 1867, that the making of Bessemer rails was fairly established in this country. In that year there were produced 2550 tons of steel rails. The superiority of steel rails over iron rails was speedily established, but for a long time their general adoption was retarded by the great cost of their manufacture. But within the past fifteen years the price has fallen from \$120 to \$30, and the result is shown in the rapid substitution of steel rails for iron as set forth in Table VIII. The production each year from 1867 to 1887, inclusive, is shown in the following statement:

Years.	Tons.	Years.	Tons.
1867	2,550	1870	34,000
1868	7,225	1871	38,250
1869	9,650	1872	94,070

Years.	Tons.	Years.	Tons.
1873	129,015	1881	1,355,519
1874	144,924	1882	1,460,920
1875	290,863	1883	1,295,746
1876	412,461	1884	1,119,291
1877	432,169	1885	1,079,400
1878	559,795	1886	1,768,920
1879	693,113	1887	2,396,397
1880	960,075		

Total tons of rails, 14,697,171.

An interesting and instructive record of the comparative productiveness as investments of the share capital and bonded indebtedness of American railroads is presented in the edition of *Poor's Manual of Railroads* for 1888. It shows the average rate per cent. of all dividend and interest payments during the past six years upon the aggregate capital stocks and bonded debts of the railroads, and is arrived at by dividing the total amount of stocks and bonds at the end of each year into the total amount of dividends and interest paid within that year. It is embodied in the following statement of percentages:

Years.	On debt.		General	
	On bonds.	(Inc. bonds).	Dividends.	Average.
1887.....	4.71	4.55	2.18	3.40
1886.....	4.75	4.53	2.04	3.26
1885.....	4.77	4.62	2.02	3.36
1884.....	4.66	4.51	2.48	3.52
1883.....	4.59	2.75	3.68
1882.....	4.40	2.91	3.65

These averages show clearly the fluctuating prosperity of railroads. In view of this showing for the past six years it is fair to assume that from the close of the civil war to the present time the average return on bonds per annum has been 5 per cent. and on stocks fully 3 per cent.

Poor's Manual of Railroads for 1888 gives also an interesting comparison of the respective productiveness in the two years 1882 and 1886 of American railroad stocks and bonds. It shows that in 1882 on a total capital stock of \$3,478,961,246, dividends aggregating \$101,967,560 were paid, the average rate of which per annum equalled 2.93 per cent. of the total, while on the remaining \$1,805,170,387, or 51.89 per cent. of the total, no dividends were paid. Upon this basis the average rate of dividends paid in 1882 upon productive stocks was 6.10 per cent.

In 1886 the showing is not quite so encouraging; for while the total amount of share capital increased \$522,403,252, the amount of productive capital increased less than \$2,000,000, or to \$1,675,669,744 (41.88 per cent. of the total), while unproductive capital increased more than \$520,000,000, rising to \$2,325,694,754, or 58.12 per cent. of the total. For this reason the total amount paid in dividends averaged in 1886 only 2 per cent. on the total amount of capital outstanding and 4.78 per cent. on the productive capital.

(J. P. M.)

RALE, SEBASTIAN (1657-1724), Jesuit missionary, was born in Franche-Comté, and entered the Jesuit order at an early age. After holding a professorship at Nîmes he was sent to Canada in 1689, and stationed first among the Abenakis. In 1692 he set out for Illinois, but spent the winter at Mackinac on the way. In 1694 he returned to the Abenakis and henceforth had his residence at Norridgewock, on the Kennebec. When the Indians resumed hostilities against the New England settlers, the latter blamed Rale for inciting them and set a price on his head. In 1705 they attacked Norridgewock and burnt the church; in 1722 they plundered the village, and in 1724 they again attacked it, and killed Rale at the foot of the cross. The *Dictionary of the Abenaki Language*, which he had compiled, was preserved in Harvard College and published by Dr. John Pickering in 1833. In the same year a monument to Rale's memory was erected at Norridgewock.

RALEIGH, the capital of North Carolina, and county-seat of Wake co., is on the Nense River, in 35° 47' N. lat. and 78° 48' W. long., and 133 miles N. N. W. of Wilmington. It has now three railroads. At its centre is Union square, containing the handsome granite State-house, which cost over \$500,000. From the square radiate the four principal streets, each 99 feet wide. The other State buildings are institutions for the deaf and dumb, the blind and the insane, the penitentiary, a geological museum, and the governor's residence; there are also a U. S. government building, a county court-house, a normal school and other schools. Raleigh has iron-foundries, car-shops, machine-shops, and manufactories of agricultural implements, carriages, and clothing. It was settled in 1792, and in 1880 had 9265 inhabitants.

RALSTON, WILLIAM RALSTON SHEDDEN, an English writer and lecturer on Russian subjects, was born in 1828, and was educated at Trinity College, Cambridge, graduating in 1850. In 1853 he was appointed assistant librarian in the British Museum, and continued there until 1875. His publications include *Kriloff and His Fables* (1869); *Songs of the Russian People* (1872); *Russian Folk Tales* (1873); *Early History of Russia* (1874).

RAMBAUD, ALFRED NICOLAS, a French historian, was born at Besançon, July 2, 1842. He was educated at the Upper Normal School, graduating in 1864, and receiving the degree of doctor of letters in 1870. He had spent some time in Russia in literary pursuits. In 1871 he was made professor of history at Caen, in 1875 at Nancy, and in 1879 was called by Jules Ferry, then minister of public instruction, to be his secretary. In 1882 Rimbaud became professor of history at Paris. His principal works are *La Domination française en Allemagne*, 1793-1804 (1873); *L'Allemagne sous Napoléon I.*, 1804-11 (1874); *La Russie épique* (1876), a study of the songs of Russia; and *Histoire de la Russie* (1878). The last two, written in a popular style, are excellent presentations of Russian thought and history, and have been translated into English.

RAMSAY, SIR ANDREW CROMBIE, Scotch geologist, was born in 1814, and educated at Glasgow University. He was appointed on the Geological Survey of Great Britain in 1841, and was made Director of it in 1845. He was appointed professor of geology at University College in 1848, and lecturer on geology in the Royal School of Mines in 1851. He became a member of the Royal Society in 1849, and received various marks of honor from universities and learned societies, American as well as European. In 1872 he was made director-general of the Geological Survey of the United Kingdom. He was president of the British Association in 1880. In the next year when he retired from his public offices the value of his services was acknowledged by granting him the honor of knighthood. Among his publications have been *Geology of Arran*; *Geology of North Wales* (1858); *Old Glaciers*

of North Wales and Switzerland (1860); *Physical Geology and Geography of Great Britain* (1878).

RAMSAY, EDWARD BANNERMAN (1793-1872), a Scotch clergyman, commonly known as Dean Ramsay, was born at Balma, in Kincardineshire, Jan. 31, 1793. He graduated at St. John's College, Cambridge, and was ordained in the Church of England. After holding a curacy in Somersetshire for some years, he became minister of St. John's Church, Edinburgh, and in 1841 was made dean. Already noted in the Scottish capital for his genial conversation and benevolent character, he gained in his old age wider appreciation by his *Reminiscences of Scottish Life and Character* (2 series, 1857-61). He also published *Diversities of Christian Character* (1858); *The Christian Life* (1859); *Pulpit Table-Talk* (1868); and a *Memoir of Dr. Thomas Chalmers* (1867).

RAMIE. See FIBRE.

RANDALL, SAMUEL JACKSON, Democratic leader, was born at Philadelphia, Oct. 10, 1828. He received an academic education and engaged in business in his native city. For four years he was a member of the city councils, and in 1858 was elected to the Pennsylvania State Senate. In 1862 he was elected to Congress as a Democrat, and has served continuously since that time, being sometimes elected without opposition. When in 1875 the Democratic party for the first time after the civil war obtained a majority in the House of Representatives, Michael C. Kerr was chosen speaker, and on his death in 1876 Mr. Randall became his successor. As such he used his influence in guiding the House through the dangerous crisis produced by the uncertainty of the Presidential election in that year. He favored the formation of an electoral commission to decide the points in dispute, and was successful in having its judgment accepted by the House. His ability as Speaker gave him prominence also as a candidate for the Democratic nomination to the Presidency in more than one National Convention. He continued to be Speaker until 1881, when the House passed again under the control of the Republicans. Financial questions have always received his especial attention. In 1883 the Democrats were again in power, but they chose Mr. John G. Carlisle speaker. The change of leaders indicated the progress of the party in the direction of tariff reduction. Mr. Randall has always advocated a tariff for revenue with incidental protection. Mr. Carlisle represents the tendency towards a tariff for revenue only. Mr. Randall's ability as a leader was still acknowledged so far that he was made chairman of the important committee on appropriations. In the closing hours of the 48th Congress, on March 4, 1885, his force of character and parliamentary skill enabled him to secure the placing of Gen. U. S. Grant's name on the retired list of the army. In the summer of 1888 he performed a similar act in having the rank of general restored in order that the dying soldier, P. H. Sheridan, might be promoted to it. After Pres. Cleveland's election, towards which Mr. Randall had contributed, he seemed to have the favor of the administration. When the increasing surplus in the U. S. treasury demanded legislative action he prepared a bill for moderate reduction in the tariff, and the removal to a great extent of the internal revenue system. Mr. Cleveland, however, steadily urged his party toward the single object of tariff reduction, and Mr. Randall became isolated. The number of Protection Democrats in the House was reduced to a handful, and Mr. Randall was silenced in the party councils. Worn out with labor, he was attacked with sudden illness in August, 1888, and compelled to retire to recruit his strength. Yet such was his hold on his own district that amid the heat of a Presidential campaign there was no opposition from either party to his re-election. (J. P. L.)

RANDOLPH. Of the Virginians of this name the most famous, John Randolph of Roanoke (1773-1833), is sketched in the *ENCYCLOPÆDIA BRITANNICA*.

PEYTON RANDOLPH (1723-1775) graduated at William and Mary College, and having studied law at the Temple, London, was made king's attorney-general in 1748. His sympathies were with the people during the conflict which soon arose with the British government. In the House of Burgesses in 1764 he drew up the address in opposition to the Stamp Act. When elected speaker of the House he resigned the office he held from the king, lest it should interfere with his duty to the people. But his brother John (1728-1784) was of a different mind and readily accepted the place. Peyton was chairman of the patriots' committee of correspondence in 1773, and when the first Continental Congress assembled in Philadelphia in September, 1774, was chosen its president. In every movement in Virginia for the rights of the people he was foremost. While attending Congress in Philadelphia, he died of apoplexy, Oct. 22, 1775.

His nephew, EDMUND RANDOLPH (1753-1813), suffered for his patriotism by being disinherited by his loyalist father, who suffered in turn for his loyalty by being compelled to seek refuge in England. Edmund, however, succeeded his father as attorney-general, was delegate to Congress, 1779-82, and governor of Virginia, 1786-88. While holding this office he took part in framing the Constitution of the United States, though the draft which he had originally prepared was not accepted by the convention. (See CONSTITUTION OF THE UNITED STATES.) He refused to sign the Constitution when completed, but urged its ratification in the Virginia Convention. He had been one of Washington's aides during the Revolutionary war, and in 1789 was appointed by him attorney-general of the United States. When Jefferson retired from the cabinet in 1794, Randolph, who had also countenanced Genet's projects, was appointed secretary of state, but in the next year he was compelled to retire in consequence of charges based on a letter from the French minister Fauchet, which was intercepted, translated, and published by the British. Randolph's *Vindication* (1795) did not suffice to restore his reputation. He died in Frederick county, Va., Sept. 12, 1813. Wirt in his *British Spy* gives a sketch of his person and services, and Moncre D. Conway, in his *Omitted Chapters of History Disclosed in the Life and Papers of Edmund Randolph* (1888), makes a strong effort to retrieve and restore his reputation. In this work the original of Fauchet's letter was published for the first time.

THOMAS MANN RANDOLPH (1770-1828) was a son-in-law of Pres. Jefferson, served in Congress during his administration, and was colonel in the war of 1812-15. In 1819 he was elected governor of Virginia. He died at Monticello, June 20, 1828.

His son, GEORGE WYTHE RANDOLPH (1820-1867), was educated at the University of Virginia and entered the U. S. navy, but was afterwards a lawyer at Richmond. He was a brigadier-general in the Confederate army, and in March, 1862, was made secretary of war in the Confederate government. In 1863 he went to France as agent of the treasury. After the war he returned and died in Albemarle co., Va., April 4, 1867.

RANGABE, ALEXANDER RIZOS, a Greek poet and statesman, was born at Constantinople in 1810, of a distinguished Fanariote family. His father was noted as a poet and had translated into modern Greek the *Æneid* and some French dramas, and also published an able work on the geography and history of Greece. The son was educated in the military school at Munich and at the end of 1829 went to Greece, where he served in the artillery. In 1832 he was appointed to a position in the department of public instruction. In 1841 he was made director of the royal press and in 1842 he was employed in the department of the interior. In 1845 he was made professor of archæology in the University of Athens, and founded and edited some literary and political journals. He was minister

of foreign affairs, 1855-59, and in 1867 he was sent as ambassador to the United States. Afterwards he was minister to France, Turkey, and finally Germany. As a representative of the Greek government he attended the Berlin Congress in 1878. Besides lyrical poems he has published a number of dramas relating to various epochs of Greek history, and translations from the ancient tragedians and Plutarch, as well as from Dante, Goethe, Shakespeare, and other modern writers. He has also published in French a *History of Modern Greek Literature* (1877).

RANKE, LEOPOLD VON (1795-1886), the distinguished German historian, was born Dec. 21, 1795, at Wiehe, in Prussian Saxony. He received his university training at Leipsic, where he studied Thucydides under Hermann and was attracted by the labors of Niebuhr and Savigny. In 1818 he became an instructor in the gymnasium at Frankfort, and in 1825 he was called to the University of Berlin as professor extraordinary of history. He was raised to the professorship in 1834. He had already entered the wider field in which he won enduring fame, and had published one volume of a *History of the Romance and German Nations* (1824). He declared his design to show the fundamental unity of modern European civilization, while yet tracing the mixture of the Romance and German elements. This volume covered the period of the Italian wars from 1494 to 1535. His original plan was then so far modified that the histories of the different states were treated independently. In an appendix to his first volume he had given a critical estimate of the authorities for the period, and had pointed out the importance of careful examination of diplomatic documents. The thorough sifting of statements previously accepted and the elucidation of what had remained obscure were the features of the new method to which he remained faithful through life. The government of Prussia gave him aid in carrying out his views and authorized him to make researches in Vienna, Venice, Florence, and Rome. The first instalment of his new series appeared in 1827, giving the history of the Turks and Spain in the sixteenth and seventeenth centuries. His attention to the main work was varied with monographs on Servian and Venetian history and lectures on Italian poetry. For a few years Ranke was associated with Savigny in editing a historical magazine, but from 1836 he devoted himself to original work. His labors on the history of the papacy, *Die Römische Papste; ihre Kirche und ihr Staat* (3 vols., 1834-37), gave him fame not merely in Germany but throughout Europe. Though not his best work it has been most widely circulated. It reached its eighth edition in 1885, and had in the meantime been translated into English by Miss Austin (1840) and into other languages. Its effect was to reveal to Protestant Christendom the true character and extent of what Ranke named the Counter-Reformation. This effect is graphically presented in Macaulay's admirable review.

In his subsequent works the historian turned from the South of Europe, dominated by Catholicism, to the North, where the Reformation had prevailed. His work here was even more important, though less widely appreciated. First came Germany, treated in his *Deutsche Geschichte im Zeitalter der Reformation* (6 vols., 1839-47), and then more particularly Prussia in the *Preussische Geschichte* (3 vols., 1847-48; subsequently enlarged, 1871-74). Ranke had been appointed historiographer of Prussia in 1841, and he amply repaid the favor which he had ever received from its royal family. Still pursuing his plan of giving elaborate histories of the several European states, he next published the history of France (5 vols., 1852-61), and that of England (6 vols., 1859-67; afterwards extended to 9 vols., 1877-79). He was allowed to retire from duty as professor in 1871, and immediately set about a thorough revision of his works, a collected edition of which had already appeared in 48 vol-

umes (1867). But the learned and vigorous old man was not content with this recast of modern history; at the age of eighty he boldly essayed to tell in his own thoroughly scientific way the history of the world from the dawn of civilization. He lived to complete twelve volumes of his *Weltgeschichte*, bringing the narrative down to the Middle Ages. This wonderful work shows no diminution of his intellectual force.

The celebration of various events in academic career gave opportunity for the government and others to bestow on him marks of honor. In March, 1865, he was raised to knighthood; in September, 1867, he was made chancellor of the order *pour le mérite*; in February, 1882, he was made a privy councillor with the title *Excellency*; in 1885 his ninetieth birthday was celebrated amid general rejoicings, and the aged Emperor Wilhelm gave the special mark of his esteem by calling upon his illustrious subject. The historian resumed his pen and labored till within a few days of his death, which occurred on May 23, 1886.

Besides the works already mentioned, Ranke edited the *Correspondence of Frederick William IV. with Chevalier Bunsen* (1873), and the *Memoirs of Count Von Hardenberg* (1876-77), and published several treatises on important epochs in German history and a volume of *Biographical Studies* (1877). The full list of his works is marvellous, even when his prolonged studious life is duly considered. He abstained from controversy and contented himself with silent correction of proved error. He refused to fritter away his time in correspondence, though he occasionally indulged in agreeable relaxation in society. Of the utmost importance was his example of patient, indefatigable investigation as the essential preliminary of genuine history. He was successful in attracting to this department the best minds among those who waited upon his instructions. Nor was his influence in this regard confined to Berlin or even to Germany. Recent historians in England and France have evidently been benefited by his guidance. In his earlier works, since his conclusions were often at variance with those of his predecessors who had not access to the same wealth of documentary evidence, he often felt obliged to fortify his statements by copious citations from original sources. In his later works such authorities were weighed more carefully, and somewhat more scope was given to the historic imagination which he had formerly studiously repressed. He avoided as a plague the generalizations characteristic of French historians, though his writings exhibit a vivacity beyond the usual reach of the German mind. He takes rank in the highest class of German historians, though possibly through the necessary limits of his method he has not attained the yet higher place of the universally acknowledged masters of historic art. (J. P. L.)

RANSOM, MATT WHITAKER, general and senator, was born in Warren co., N. C., Oct. 8, 1826. He graduated at the University of North Carolina in 1847, and was then admitted to the bar. From 1852 to 1855 he was State attorney-general and in 1858 he was elected to the State Legislature. He attended the Confederate Congress at Montgomery, Ala., in 1861, and soon after entered the Confederate army as lieutenant-colonel. He served throughout the war and attained the rank of major-general. He was elected to the U. S. Senate in 1872, and has since been twice re-elected.

RANSOM, THOMAS EDWARD GREENFIELD (1834-1864), one of the bravest generals in the American civil war, was born Nov. 29, 1834, at Norwich, Vt. He was educated in that city at the military institute, conducted by his father, Col. Truman B. Ransom, who was killed in the Mexican war. The son afterwards went to Illinois and became a civil engineer and real estate agent. On the outbreak of the war he raised a company of volunteers and was appointed major of the 11th Illinois Regiment. After gallant service in Missouri he was engaged in the capture of Forts

Henry and Donelson. Though wounded at the latter, he took part in the battle of Shiloh six weeks later. In June, 1862, Gen. McClelland appointed him chief of his staff and inspector-general of the Army of the Tennessee. He was appointed brigadier-general in November, 1862, and his services in Mississippi in the next year called forth high commendations. In his *Personal Memoirs* Gen. Grant speaks of Ransom as a "most gallant and intelligent volunteer officer," and says "that after the siege of Vicksburg he was well qualified to command a corps. Ransom was in Banks' Red River campaign, and for a time had command of McClelland's corps. He was again wounded at Sabine Cross-Roads in April, 1864, but he recovered in time to lead a division in the campaign against Atlanta. Here he succeeded to the command of the 17th corps. His ardor led him to overtask his body, enfeebled by illness, and he died at Rome, Ga., Oct. 29, 1864. Throughout his brief career he was distinguished not only for military ability and energy but for the highest Christian character.

RANUNCULUS, a genus of plants, comprising the well-known Buttercup or Crowfoot. The natural order *Ranunculaceae* consists of plants having a separate calyx and corolla, the petals usually numerous, hypogynous, with numerous stamens, and the pistils all distinct and unconnected. *Ranunculus* has the petals imbricated in the bud, not valvate as in *Anemone*, and is well characterized by the solitary erect seed and a scale or pore inside the petal at the base. Representatives of the genus are found over the cooler parts of Europe, Asia, and America and in the mountainous parts of warmer latitudes,



Ranunculus.

about one-third existing either as natives or introduced species in the United States. In mountainous regions the flowers of some species are larger than the common field-buttercup, while the plants are much diminished in size, as most Arctic plants are. The name "Crowfoot" is derived from *Ranunculus Asiaticus*, which has a cluster of small black roots not unlike the foot of a crow. As often happens in such cases, the name has crept over the whole genus, embracing those with fibrous and bulbous roots as well as those of the original crowfoot style. In the United States "Crowfoot" is not often used as a common appellation, "Buttercup" having gained the popular appreciation. The origin of this common name is uncertain, but perhaps the butter-colored flower-cup may have been quite sufficient to suggest the name. The generic name, *Ranunculus*, denotes a little frog or tadpole, the connection between the two not being apparent, except that this plant, like many others, is found in marshy places.

Two of the leading Buttercups of Europe have flourished by introduction to the New World. In the New England States *Ranunculus acris* has found itself completely at home, and is one of the worst weeds the farmer has to contend with. Farther south, *Ranunculus bulbosus* is the prevailing Buttercup. *R. repens* is occasionally found. *R. sceleratus*, named from its excessive acrid qualities, as its specific name implies, the "Cursed Buttercup" or "Crowfoot," is found only abundantly along water-courses.

The acrid property is a strong characteristic of the genus. Before cantharides was introduced it was in general use for raising blisters. Cattle feeding on the leaves get sore mouths and often ulcerated intestines.

In the hands of careful practitioners the various species still serve useful purposes in medicine. In pasture-lands they cause great loss to the agriculturist from the amount of ground lost by their occupancy. The plant loses much of its acidity by drying, so that it is not as objectionable in hayfields as in pastures. It is easily destroyed by ploughing up the pasture-ground and putting it for a season in corn or potatoes. Most of the kinds growing wholly in water are free from acidity. *R. aquatilis* is a favorite food of cattle in Europe, and they thrive on it. Like most plants of this acid character, the bitter property is removed by boiling; when cooked many species are eaten as greens in the Old World. None of the truly indigenous specimens have obtruded themselves on the notice of the agriculturist in the United States. In California, *R. Californicus*, a species having some affinity to the *R. acris* of Europe, is very abundant in the Coast ranges, so much so that the low grassy hills are often yellow with the shining flowers in early spring.

(T. M.)

RAPHAIL, MORRIS JACON (1798-1868), a Jewish rabbi, was born at Stockholm, Sweden, in September, 1798. He was educated at a Jewish college in Copenhagen, and in 1812 went to England for further study. After a Continental tour he spent three years at the University of Giessen, and in 1825 settled in England. In 1832 he began to deliver in London lectures on the Post-Biblical history of the Jews, and in 1834 he established the *Hebrew Review*, in which he published translations from the works of Maimonides and other celebrated rabbis as well as original poems and sketches. In 1840 he visited Syria on a mission to the Jews, and in 1841 he was called to be rabbi of a synagogue at Birmingham. He was prominent in various movements for the advancement of his race. In 1849 he was called to New York to be pastor of the congregation B'nai Jeshurun, and here became noted for his oratorical ability. He died June 23, 1868. His most noted work is the *Post-Biblical History of the Jews* (2 vols., 1856). He also published some devotional treatises.

RAPP, GEORGE (1770-1847), the founder of the Communistic religious sect of Harmonists, was a native of Württemberg, Germany, born in 1770. While still a youth he believed that he had experienced a divine call and was charged with the restoration of the Christian religion to its pristine purity. He did not long confine his efforts to spiritual instruction, but formed a plan of a community to be modelled on the system of the primitive church, all goods to be the common property of the association. In the realization of this project he found himself so hampered by state interference in Germany that he resolved to emigrate to America, where he hoped to be able to carry out his plans without official opposition. He reached this country in 1803, accompanied by a band of believers in his religious, social, and political views, and in 1805 founded the town of Harmony, on Conquequessing Creek, Butler county, Pa., where the community engaged successfully in agriculture and manufacture. In 1815 they removed to a new location on the Wabash River, Ind., where a tract of 27,000 acres was obtained, and a settlement started under the name of New Harmony. Here the Harmonists became involved in pecuniary difficulties, and in 1824 sold this land and improvements to Robert Owen, who wished to try a socialistic experiment on a different plan. Rapp and his followers returned to Pennsylvania, and founded towns called Economy and Harmony, in Beaver county, on the banks of the Allegheny, 17 miles northwest of Pittsburg. Rapp died here on August 7, 1847, but the community is still in existence. It owns 3500 acres of land, and in addition to agriculture is engaged in silk, woollen, and cotton manufacture. The industry and morality of the members of the community have gained it general esteem, and it stands as one of the few communistic

experiments that have had any measure of success. (See COMMUNISM.) (C. M.)

RASPAIL, FRANÇOIS VINCENT (1794-1878), a French scientist and revolutionary politician, was born at Carpentras in the department of Vaucluse, France, Jan. 29, 1794, and attained the chair of philosophy in the college of his native place. He was called to pronounce the oration there on the anniversary of the battle of Austerlitz, and this, on being submitted to Napoleon, elicited the remark: "Surveille ce jeune homme, il ira loin." In 1815 he hailed with joy the return of the Emperor and composed a song which was sung with enthusiasm everywhere. Removing to Paris in 1816 he took part in all the plots of the Restoration-period. In the Revolution of July, 1830, he was severely wounded. Later he was instrumental in founding the club of "The Friends of the People," and wrote a number of fugitive pieces against the July government, for which he suffered an imprisonment of 15 months. On the compulsory dissolution of "The Friends of the People" in 1832, he took part in founding "The Society of the Rights of Man." For a time he studied law, but, disgusted with its dry details, he turned from it and gave himself with enthusiasm to the natural sciences. His scientific writings of this earlier period were devoted to organic microscopic chemistry and to vegetable physiology. Beside general treatises he published *Histoire Naturelle de l'Insect de Gale* (Paris, 1834).

On the outbreak of the riots of April, 1834, he was again made prisoner, but being released after a short captivity he founded a revolutionary daily paper, *Le Reformateur*, which lived about a year. Raspail now devoted himself with redoubled zeal to science, and matured his camphor-system of medicine, proclaiming camphor as a specific against the germs of all, or most, zymotic diseases. This theory was set forth in his *Histoire Naturelle de la Santé et de la Maladie* (3 vols., 1839-46) and in several medical annuals which had extensive sale. On Feb. 24, 1848, at the head of a riotous mob, he stormed his way into the council chamber of the Provisional Government in the Hôtel de Ville, and compelled this body to proclaim the Republic. On February 27 appeared the first number of his *Ami du Peuple*, whose teachings he enforced by the establishment of a revolutionary propaganda through clubs of the "Friends of the People." Again, on May 15, he invaded the sitting of the National Assembly. Brought for this outrage along with Blanqui and other ringleaders before the high court of justice in Bourges, he was sentenced to six years' imprisonment in the citadel of Doullens. This confinement like the many others he had to undergo he utilized for the purposes of science, producing in his cell several of his most valuable works. In 1853 the Imperial government permitted him to exchange imprisonment for exile, and he settled in a village in Belgium. Elected a member of the Legislative Corps in 1869, he attached himself to the party of the extreme left and associated especially with Rochefort (*q. v.*). In 1876 he was chosen a member of the Chamber of Deputies. He died Feb. 8, 1878, at Arcueil near Paris. Besides almanacs and scientific and medical reviews he published *Reformes sociales* (1872).

His son, BENJAMIN FRANÇOIS RASPAIL, born at Paris, Aug. 16, 1823, has trod in his father's footsteps. In 1849 he was elected to the Legislative Assembly, but being proscribed in 1851, sought refuge in Belgium and did not return to France till 1863. In 1876 he was elected to the Chamber of Deputies, where he took his place on the extreme left.

RASPBERRY, a member of the botanical genus *Rubus*, order *Rosaceæ*. The species of this genus, commonly known as brambles, are divided into two sections—the blackberry, in which the receptacle is non-persistent, juicy, and becomes part of the fruit, and the raspberry, with a persistent, dry receptacle, from which the fruit separates when ripe. The genus

is made up of shrubs and a few herbaceous, perennial plants, mostly with compound leaves, the fruit being one-seeded, pulpy drupes, which cohere in a head or cluster above the open calyx. The species of *Rubus* are very variable, there having been more than 500 described, though there are probably not over 100 good species.

The Eastern United States have two very common species, *R. strigosus*, the red, and *R. occidentalis*, the black raspberry, which yield favorite fruit in the wild state, and both of which are cultivated. These species have biennial, woody, and prickly stems, the leaves having 3 to 5 leaflets. The red raspberry extends from Newfoundland to Oregon, and southward to the Middle States. It has upright, prickly stems, and propagates itself by underground runners, which send up suckers from which new plants rise. These grow to a height of 5 or 6 feet in one season, bear fruit the next, and then die. This species abounds in the North, particularly on new clearings. Its fruit is of a light red color, and is yielded in profusion all summer. It is nearly, or quite, identical with *R. Idarus*, the European garden raspberry.

The black raspberry is more southerly in its range, and extends as far as Georgia. Its fruit is black in color, ripens in July, and is drier than the red berry. Its mode of growth is different, as it makes no suckers, the new shoots springing from the base of the old plant. Late in summer the branches, which become very long, bend over till their tips touch the ground, when they take root and yield new plants. In cultivation the bending tips are covered lightly with earth. This species, known as black-cap and thimbleberry, is common around old stumps and in fence-corners. When cultivated in deep, loamy soil the fruit increases nearly one-quarter in size.

There are several interesting American species belonging to another section of the raspberry group, in which the plants are not prickly, have simple leaves and large flowers, and the fruit is very broad and flat. The most interesting of these is *R. odoratus*, the rose-flowering, or the Virginia raspberry, as it is called in England. The flower is of a rich, rose-purple color, about 2 inches across: the fruit sometimes an inch broad, dry, but of pleasing flavor. This species is found in rocky places, from Canada to Georgia. Other species are *R. Nutkanus*, the white-flowering raspberry of the north-east coasts; *R. deliciosus*, the Rocky Mountain raspberry, a species with very large, white flowers, and fruit of indifferent flavor; and *R. chamamorus*, the cloud-berry, a creeping plant of the Arctic regions of Europe and America.

Of cultivated raspberries, one of the best varieties is the Hudson River Antwerp, a red variety of supposed European origin, which is grown abundantly along that river, and supplies the New York market. The Philadelphia raspberry is another prolific bearer, not of best quality, yet a profitable variety. Other favorite varieties of the red berry are the Cuthbert and the Hansell; of the black, the Gregg, which yields large fruit of excellent flavor and in great quantity. Of the yellow varieties, the Caroline and Brueckle's Orange rank among the best. In some sections the raspberry is less hardy than the blackberry, and it is best to cover the cultivated varieties for the winter with from 3 to 6 inches of corn-stalks, straw, etc. The fruit of the raspberry is too well known to need remarks. It forms an excellent dessert fruit, of subacid flavor, and is much used in making conserves, jellies, and other delicacies for the table and sick-room, and an agreeable summer beverage known as raspberry vinegar. (C. M.)

RASSAM, HORMUZD, an Assyrian explorer, was born in 1826, at Mosul, on the Tigris, opposite the ruins of Nineveh. He was of native Chaldaean descent, but his family became connected by marriage with that of Rev. George Percy Badger (q. v.). He assisted Layard in his explorations of Nineveh in 1845,

and accompanied him to England, where Rassam pursued a regular course of study at Oxford. In 1849 he returned to Mesopotamia to prosecute further the excavations at Nineveh, and when Mr. Layard withdrew from the work Mr. Rassam became the superintendent in behalf of the British Museum. After his return to England, in 1854, he was employed by the British government at Aden, and in 1864 he was despatched to Abyssinia to procure the release of Consul Cameron. He was, however, himself seized by King Theodore, and kept prisoner for nearly two years, until the close of Lord Napier's campaign, in April, 1868. Rassam published a *Narrative of the British Mission to Theodore, King of Abyssinia* (2 vols., 1869). After the death of George Smith, the Chaldaean explorer, Rassam was chosen, in 1876, to succeed him in his work under a liberal firman obtained from the Turkish government. Among his discoveries were the bronze gates of Balawat, 22 feet high, bearing memorials of the wars of Shalmanezzer II., which, with other treasures, were safely deposited in the British Museum. Again, in 1878, Rassam was sent to make new explorations in other parts of the Turkish dominions in Asia. He was engaged in these archaeological researches until July, 1882, having explored the ruins of Sipar, the Sepharvaim of the Bible, and of the Babylonian Cethra.

RAT. The two species of rat most common in the United States are the brown rat and black rat described in the *ENCYCLOPÆDIA BRITANNICA*. The general characters of the rats, and the relationship of their genera and specie to each other and to the other rodents, are stated in the same work in the article MOUSE. There are, however, native American species of rat, all of which are sigmodont, rather than strictly murine, in their dentition. The old-world species, and especially the brown rat (miscalled Norway rat), are rapidly displacing the native species. The cotton-rat of the Southern States (*Sigmodon hispidus*) is the best known of our native rats. It is smaller than the common brown rat, and much less fierce and aggressive. (See COTTON RAT.) The Florida wood-rat (*Neotoma floridana*) is a large and handsome creature, with soft and delicate fur, which ought to have a commercial value. The squirrel-tailed wood-rat of the Rocky Mountains is very remarkable for its habit of building a great nest or house of sticks and brush, often in some tree or clump of large shrubs. This creature is a great thief, and is one of the pests of the frontiersman's life, carrying away to its secret stores towels, spoons, knives, soap, or any portable article not too large for it to handle. Its flesh is said to be very palatable, more so than that of any squirrel or rabbit. Not unfrequently various species of the mouse kind quarter themselves as guests in the commodious house of this curious wood-rat, where they appear to be well received. South America has quite a number of large rat-like rodents, for the most part little known to science. (C. W. G.)

RATIONALISM. As intimated in the *ENCYCLOPÆDIA BRITANNICA*, this term is capable of a much wider application than is there discussed. Lecky, whose *History of Rationalism in Europe* is one of the most widely read books of modern times, thus states his own conception of a proper use of the term: "It [rationalism] leads men on all occasions to subordinate dogmatic theology to the dictates of reason and of conscience, and, as a necessary consequence, greatly to restrict its influence upon life. It predisposes men in history to attribute all kinds of phenomena to natural rather than miraculous causes; in theology, to esteem succeeding systems the expression of the wants and aspirations of that religious sentiment which is planted in all men; and in ethics to regard as duties only those which conscience reveals to be such." This will be recognized as a marked departure from

the definition accorded to the term "rationalism" by the earlier writers on the subject. In itself it is an indication of a modified process on the part of rationalists, while the domain of their inquiry and investigation is enlarged. To its progress is assigned the credit of sweeping away faith in magic and witchcraft, of destroying fetishism and faith in miracle, anthropomorphism, relic-worship, and finally persecution itself. These beneficent results are ascribed to rationalism, which owed its power in England largely to the reaction against Puritanism, the influence of Hobbes, and the Baconian philosophy, as represented by the Royal Society.

Rationalism, however, in its proper interpretation and ultimate analysis, elevates the reason as the sole arbiter in religion, and, by a necessary consequence, denies to the historian the use of facts and to the ethical inquirer the use of emotions or of conscience. Certain *a priori* truths determine everything else. It is not difficult to see that such a narrow basis in philosophy or in theology must sooner or later reveal its insufficiency. Applied to statesmanship, it would demand that in government all the fruits of history should be ignored; to political economy it would deny the records of markets; and to religion everything of an experimental and emotional character. In short, its opponents claim that it is equally inconsistent to relegate the ultimate appeal in matters of religion solely to reason, as it would be to confine our judgment of the properties of matter to any one of the five senses, excluding the others.

Lecky's definition, given above, is an indication of the extent to which rationalists themselves have departed from the early principles of a rationalistic philosophy, and have attempted to bring to their aid other powers than those of reason alone.

The root of modern rationalism is probably to be sought in the Cartesian philosophy. Des Cartes' syllogism of universal doubt could not help, sooner or later, invading the realm of theology, and we are not surprised to find him followed by philosophers of his own school, who claim for reason a place as infallible as is accorded to the Divine Creator of reason.

The rationalism of Germany owed its remarkable prevalence to several concurrent causes. The mysticism of the Pietists on the one hand contributed to bring the stricter forms of orthodoxy into contempt. Prominent theologians, like Michael Lang of Altdorf, J. Lange and Rambach, claimed for the witness of the Spirit a superior place to the teachings of dogmatic theology. The "inner spark," the "inner word," became a substitute for system and creed, until serious and devout men began to feel that uncertainty rested upon all religious conclusions. The Bible itself was regarded as of so little authority that to the cultured and learned men of the time it was little better than a book of fable.

This result had been hastened by the demoralization consequent upon the Thirty Years' war, which debased the nobles and the masses alike, so that infidelity became almost universal. Then came German Idealism, with its beautiful but deceptive promise, and under Kant sought to counteract the method pursued by Voltaire and Volney, and the French Encyclopædists. It was designed to oppose the deists on the one hand and the supernaturalists on the other, and to establish its principles on the basis of the superiority of reason to revelation, while the fact of the existence of a credible revelation was assumed. Semler, J. G. Michaelis, and J. G. Eichhorn were among the early theologians to apply this philosophy to theology. Of these, Eichhorn may be regarded as the most important writer. He developed his principles in his *Universal Library of Biblical Literature* (10 vols., Leipzig, 1788-1801), and in his *Introduction to the Old and New Testaments*, which appeared in 7 volumes, at Göttingen, in 1824.

Singularly enough, the philosophers whose metaphysics furnished the basis for these theological con-

clusions, like Fichte and Schelling, do not hesitate to stigmatize the work of these rationalists as commonplace and vulgar. The greatest, and by all means the most powerful, exponent of the school of rationalism was Dr. H. E. G. Paulus (1761-1851). He held that we must discriminate between statements of facts and of opinions in the Bible. A fact is that which has occurred within their experience; an opinion is their expression of the conditions under which it occurred. As these are naturally and necessarily confused in Bible records, it is the duty of the critic to separate them. Of course, all supernatural or divine interference is denied and miracles are discredited. Christ, according to this view, was not divine, but he was a wise and virtuous man. He wrought no miracles—what appeared such were simple events, easily explained. The healing of the blind was due to an efficacious powder secretly applied to the eyes. The transmuting of the water into wine never occurred—Christ simply had his disciples bring wine, where nothing but water had been provided. Peter sold a fish, and thus secured the money for tribute, etc. These are given simply as illustrations of that form of rationalism which sought its basis in the ideal philosophy. According to its theories, truth was to be sought not by empirical processes at all, but in the line of certain *a priori* principles by which all truth is to be judged. Guided by these principles, the rationalists sought to explain the truths of theology. Some doctrines of Christianity were allegorized, many others were swept away altogether.

The German idealists, of whom Kant was incomparably the greatest, were succeeded in their influence upon theological thought by Frederick Henry Jacobi (1743-1819), one of the most powerful thinkers of any time. He insisted that all knowledge communicated to us by the understanding (reason) is contingent, and never universal, infinite, or purely philosophical. To demonstrate any truth we must infer it from another and so on to an infinite series. All human knowledge, he insisted, depends at last on faith or intuition. Sensation itself, he affirms, is a mystery and our knowledge of it rests on our faith in our memory of its presence. God, providence, freedom, moral distinctions, are ideas that do not come to us by proofs. They are ours by intuition. It is by the twofold office of this faculty therefore that we cognize two worlds—the whole material of truth comes within the scope of our knowledge and man is thus prepared to approach the questions of this world and of the world to come; "the immediate certainty of feeling" was emphasized, and it was claimed that every perception proved something actual present, whose existence and conditions were independent of our internal laws and faculties. He was followed by Bouterwek, Krug, Fries, Schlegel, Novalis, Schubert, Baader, and others who pursued his principles with varying success. Greatest among all those who availed themselves of the fruits of his philosophy was F. D. E. Schleiermacher (1768-1834). This wonderful philosopher and divine, while he is properly classified as a modified rationalist, wrought effectively to save theology from the destructive tendencies of his predecessors. He gave to German thought an uplifting that prepared it for Hase's *Huterus Redivivus*, which was the deathblow to German Rationalism and so effectively destroyed it that instead of being recognized as scientific it is henceforth distinguished as "Rationalismus Vulgaris."

The writings of Strauss and Renan seem to proceed upon the basis of an endeavor to find at the bottom of the Gospel narrative some veritable history. In the work of Strauss there is an attempt to explain by what is known as the mythical theory the prevalent beliefs of Christianity. According to him Christ really lived and taught and died, but his disciples innocently poetized his life, and having been rudely shocked by his dying, were really comforted by the mistaken belief that he had risen from the dead. These myths which

constitute the Gospel history were according to Strauss not invented by any single individual, but were the offshoot of the collective impression of a community or communities of people.

According to Renan these accounts were rather the transfiguration of fact than a pure creation of pious enthusiasm. Christ's disciples, partly through pious fraud and partly by blind enthusiasm, secured the appearance of the miraculous, to which deception Christ interposed no objection. The resurrection of Lazarus was a pretended resurrection contrived by Christ's disciples for popular effect, to which Jesus reluctantly yielded his assent and pretended agency.

But these later authors have exercised little permanent influence, and their writings are interesting chiefly as they relate to the history of rationalism. Theodore Parker (1810-1860) is the only American of prominence whose name is associated with rationalism, but his position is so imperfectly defined that such a classification may at least be said to be doubtful. (See PARKER, THEODORE, in the *ENCYCLOPÆDIA BRITANNICA*.)

The present time seems to be marked by an attempt to use the word Rationalism in a broader sense than has been attributed to it in the philosophic movements of the past. It is neither naturalism, rationalism in its narrowest sense, nor supernaturalism, all of which have been included in one classification by some of the writers on this subject. The claim which is made under this term in its latest use embraces all progress by which the world has emancipated itself from superstition and error and come under the sway of enlightened reason.

Whether the attempt to make it synonymous with a true social economy, which is the essay of Lecky, shall be successful or not remains yet to be determined.

Literature.—Bockhammer, *Offenbarung und Theologie* (Stuttgart, 1822); Cornil, *Feuerbuch und seine Stellung zur Religion und Philosophie der Gegenwart* (Frankfurt a. d. Main, 1851); Ilenhofer, *Der Kampf des Unglaubens* (Heidelberg, 1861); Hurter, *Ueber die Rechte der Vernunft und des Glaubens* (Innsbruck, 1863); Clifford, M., *A Treatise of Human Reason* (1675); *Plain Dealing* by A. M. (anon.), a reply to above (London, 1675); Draper, J. W., *Intellectual Development of Europe* (N. Y., 1863); Farrar, A. S., *Free Thought in Reference to the Christian Religion* (London, 1863); Hurst, J. F., *History of Rationalism* (N. Y., 1866), reviewed in *Edin. Rev.*, v. 121, 1865; *Fortnightly Rev.*, v. 1, 1865; *Littell*, 1866, v. 2 (by Geo. Eliot); Hedge, *Reason in Religion* (Boston, 1865); Mackay, R. W., *Tübingen School and its Antecedents*; Mackenzie, G., *An Essay on Reason*, in *Essays* (1713); Mansel, H. L., *Free Thinking, its History and Tendencies*, in his *Letters*, etc. (London, 1873), and *Limits of Religious Thought* (N. Y., 1859); Tulloch, John, *Rationalism* (*Contem. Rev.*, v. 1, 1866), and *Rational Theology and Christian Philosophy in the 17th Century* (*Edin.*, 1874); Fisher, G. P., *Faith and Rationalism* (N. Y., 1879); Lecky, W. E. H., *History of Rationalism* (N. Y., 1878); Cook, J., *Scepticism and Rationalism* (London, 1851); Salvagnini, O., *Cinque Contisti e Razionalisti* (Firenze, 1879); Rosmini Serbati, *Il Razionalismo che tenta insinuarsi nelle scuole teologiche addito in opuscoli* (Prato, 1822). (T. A. K. G.)

RATTLESNAKE. See SNAKES.

RAU, CHARLES (1826-1887), archaeologist, was born at Vervien, Belgium, in 1826. After finishing his education in Germany he returned to the United States in 1848 and engaged in teaching. Becoming deeply interested in American archaeology during his residence in the West, he contributed on this subject first to European periodicals, and from 1863 onward to the reports of the Smithsonian Institution. For *Harper's Magazine* he wrote a series of articles on the "Stone Age in Europe," which afterwards formed the volume, *Early Man in Europe* (1876). In 1875 he was appointed a curator in the archaeological department of the U. S. National Museum at Washington and he held this post till his death. Besides some monographs he published a catalogue of the Museum (1876), and several of his fifty papers were collected under the title *Articles on Anthropological Subjects*

(1882). He died at Philadelphia, July 25, 1887, leaving two works in an unfinished state. His eminence as an anthropologist was widely recognized, as was shown by his membership in all the European and American archaeological and anthropological societies.

RAUCH, FREDERICK AUGUSTUS (1806-1841), educator, was born at Kirchbraecht, Hesse-Darmstadt, July 27, 1806. He was educated at the Universities of Marburg, Giessen and Heidelberg, and was for a time professor in the last named. In 1831 he removed to the United States, and entered the ministry of the German Reformed Church. He was, however, chiefly engaged in educational work, being professor of German at Lafayette College, and principal of academies at York and Mercersburg. When a theological seminary was established at the latter place he was made professor of Biblical literature in it, and when Marshall College was founded there in 1836 he was made president. He died at Mercersburg, March 2, 1841. His principal English work is *Psychology* (1840).

RAUMER, FRIEDRICH LUDWIG GEORG VON (1781-1873), German historian, was born at Wörlitz, May 14, 1781. He studied law at the Universities of Halle and Göttingen and had entered the Prussian civil service, but in 1811 was made professor at Breslau and in 1819 professor of political science and history at Berlin. As early as 1806 he had published *Sechs Dialoge über Krieg und Handel*, and in 1810 *Das britannische Besteuerungssystem*. In 1821 his lectures on ancient history were published, and they passed through four or five editions in his lifetime, as did also his *Geschichte der Hohenstaufen und ihrer Zeit* (6 vols., 1823-25; 5th ed., 1878). This noted work clearly displays his ability as a philosophic historian, his masterly combination of insight with practical experience. Von Raumer's interesting essays on the *Development of the Ideas of Law, the State and Politics* first appeared in 1826, and the third edition in 1861. After some *Letters from Paris* on the history of the 16th and 17th centuries, he undertook his great work *Geschichte Europas seit dem Ende des 15. Jahrhunderts* (8 vols., 1832-50). By translations of this work he is chiefly known outside of Germany. It is second only to the labors of Ranke in the same field. Von Raumer was attracted to England by the historical treasures of the British Museum and other repositories, and while using these for essays he also published his impressions of the country and people. He next visited Italy and finally the United States. His description of the latter, of whose political institutions he was a warm admirer, was published in 2 volumes at Leipsic in 1845. Two years later he resigned his post as secretary and member of the Berlin Academy on account of the unfavorable reception of his address on Frederick II. He was elected to the Frankfort national assembly in 1848, and joined the moderate conservatives. He had also some diplomatic experience at Paris, of which he published an account, and on his return became a member of the Prussian parliament. Although he resigned his professorship in 1853, he continued for some time longer to give lectures. His later writings, besides a *Hand-book of the History of Literature* (4 vols., 1864-66), were chiefly letters and reminiscences. He founded the *Historische Taschenbuch* (Series 1-4, 1830-67), which was renewed in 1871, and continued after his death. He died at Berlin, June 14, 1873.

His brother, **KARL GEORG VON RAUMER** (1783-1865), scientist, was born April 9, 1783, in Wörlitz, near Dessau. He studied law at Halle and Göttingen and thereafter attended the Mining Academy at Freiberg, on leaving which he made geognostic tours in Germany and France. From 1806 to 1811 he filled several legal offices, and in the latter year was appointed professor of mineralogy at Breslau. In the German War of Liberation he served in 1813-14 as adjutant on Blücher's general staff; in 1819 became a professor in Halle; in 1823, a co-director of the Dittmarsch Edu-

ational Institute, in Nuremberg; and finally, in 1827, professor of mineralogy and natural history in the University of Erlangen. His geographical and geological writings acquired wide fame. Among his works may be noted: *Geognostische Umrisse von Frankreich und Gross Britannien* (1816); *Das Gebirge Niederschlesiens* (1819); *Lehrbuch der allgemeinen Geographie* (1832); *Palästina* (1835); *Der Zug der Israeliten* (1837); *Geschichte der Pädagogik* (1842), which passed through several editions; *Erinnerungen an die Freiheitskriege* (1850); *Die Erziehung der Mülchen* (1853). He died at Erlangen, June 2, 1865, and his *Autobiography* was published in 1866. His son, RUDOLF VON RAUMER (1815-1876), was noted as a philologist, and was professor of German language and literature at Erlangen from 1852 till his death.

RAWLE, WILLIAM (1759-1836), jurist, was born at Philadelphia, April 28, 1759. He was of Quaker descent and studied law in New York, London, and Paris. Returning to Philadelphia in 1783, he became distinguished in his profession. In 1789 he was elected to the Pennsylvania Legislature, and in 1791 he was appointed U. S. district attorney. He held this office eight years, having in the meantime declined the position of U. S. attorney-general. He was the first president of the Pennsylvania Historical Society, and received the degree of LL. D. from Princeton College, in 1827, after the publication of his excellent *View of the Constitution of the United States* (1825). He was long at the head of the Philadelphia bar, and students were attracted by his fame from distant places. He died April 12, 1836. See his *Memoir* by T. J. Wharton (1840), and a tribute to his memory in D. P. Brown's *Ferriam* (1856). His son, William Rawle (1789-1858), published several volumes of *Pennsylvania Reports*, and his grandson, William Henry Rawle, born in 1823, has published the *Law of Covenants for Title*, and other legal works.

RAWLINS, JOHN AARON (1831-1869), general, was born at East Galena, Ill., Feb. 13, 1831. He was brought up to a frontier farmer's life, but showed fondness for reading. He studied law at Galena and was admitted to the bar in 1855. He became noted as a speaker in the exciting political campaigns of the time, and in 1860 was a candidate for Presidential elector on the Douglas ticket. On the outbreak of the war he ardently supported the cause of the Union, and in September, 1861, U. S. Grant, on receiving his commission as brigadier-general, appointed his fellow-townsmen Rawlins assistant-adjutant-general, with the rank of captain. He remained in close relation to Gen. Grant till the close of his life. He was made brigadier-general in 1863, and chief of staff to the lieutenant-general March 5, 1865. Gen. Grant frequently bore testimony to his ability and integrity, and on becoming President he appointed Rawlins Secretary of War, but after six months' tenure the latter died, Sept. 6, 1869. A bronze statue of him has been erected in Washington.

RAWLINSON, GEORGE, an English clergyman and historian, was born at Chadlington, Nov. 23, 1815. He was educated at Ealing School and Trinity College, Oxford, graduating in 1838. He was made fellow of Exeter College and after holding a tutorship for some years was appointed classical moderator at Oxford in 1852, and public examiner in 1854. In company with his brother Henry and Sir George Wilkinson, he prepared an annotated English translation of *The History of Herodotus* (1858-60). He delivered the Bampton lectures in 1859 on *The Historical Evidences of the Truth of the Scripture Records* (1860). In 1861 he was made Camden professor of ancient history at Oxford and took part in the movement for University reform. In 1872 Prof. Rawlinson was made a canon of Canterbury. He had in the meantime continued his literary labors and had published *The Five Great Monarchies of the Ancient Eastern World* (4 vols., 1862-67). To this he afterwards added a *History of*

the Parthian Empire (1870), and finally *The Seventh Great Oriental Monarchy; the Sassanian Empire* (1876). He has published some smaller works on historical and Biblical subjects, and has contributed to Smith's *Dictionary of the Bible*, the *Speaker's Commentary*, and other works. Of his later works may be mentioned *The Origin of Nations* (1878); *History of Egypt* (2 vols., 1881); *Religions of the Ancient World* (1882); *Egypt and Babylon from Scripture and Profane Sources* (1884).

His elder brother, SIR HENRY CRESWICK RAWLINSON, was born in 1810, and served in the Bombay army from 1827 till 1833, when he was sent to Persia, where he was actively employed until 1839. In the next year he was appointed political agent at Kandahar where, amid the troubles of the Afghians, he succeeded in preserving peace. In March, 1844, he was appointed consul at Bagdad, and in 1851 consul-general. In 1853 he resigned this post and was made a director of the East India Company, and in 1856 K. C. B. In 1858 he was for a short time a member of Parliament, and in September was made a member of the council of India. In April, 1859, he was sent as envoy to Persia. He was again in Parliament 1865-68, and was then reappointed a member of the council for India. In 1878 he was made a trustee of the British Museum. He has published many papers on the antiquities of the East, and gathered into a volume *England and Russia in the East* (1875).

RAY, ISAAC (1807-1881), alienist, was born at Beverly, Mass., in 1807. He graduated at Bowdoin College in 1827 and studied medicine. While engaged in practice at Eastport, Me., he entered on the study of insanity, the result of which was given in his *Medical Jurisprudence of Insanity* (1838). He was called to take charge of the State Insane Hospital, at Augusta, and in 1845 was made superintendent of the newly established Butler Hospital, at Providence, R. I. In 1866 he removed to Philadelphia, and he died there March 31, 1881. He published several treatises on mental health, and contributed on the same topic to medical journals.

RAYLEIGH, JOHN WILLIAM STRUTT, BARON, was born at Ferling Place, Essex, England, Nov. 12, 1842. Being of a delicate constitution, he was placed under a private tutor, and early developed a fondness for experimental research, his chief amusement while young being in photography. In October, 1861, he entered Trinity College, Cambridge, where he was classed by his fellow-students among the "reading men." He took several prizes and graduated with distinguished honors, being both senior wrangler and Smith's prizeman. Trinity elected him a fellow, as is the custom towards students who distinguish themselves in the final examination. On June 14, 1872, he succeeded to his title of Baron Rayleigh, and in the same year was elected a Fellow of the Royal Society, to whose *Transactions* he had contributed many important papers. In 1882 the medal of this society was conferred upon him, in recognition of the importance of his scientific work. On the death, in 1879, of Clerk Maxwell, professor of Experimental Physics at Cambridge, Lord Rayleigh was elected to the professorship, and since then has devoted much time to the organization of the magnificent Cavendish laboratory. In 1884 he was president of the British Association during its session in Montreal.

Lord Rayleigh's writings are scattered through the proceedings of several of the learned societies of England. Some of them have been collected into a volume and published separately, but the deep mathematical studies involved render them too difficult for general reading. His only extended work, *The Theory of Sound*, is a valuable mathematical treatise in two volumes. He also wrote the article on "Optics" for the *ENCYCLOPEDIA BRITANNICA*. His determination of the ohm was accepted by the Paris Conference of Electricians (1883-4) as the basis of electrical resist-

ance, and his recent experiments on measuring the strength of the electrical current by the deposition of silver promise to result in a method of great accuracy. Lord Rayleigh is still actively engaged in the study of optics, electro-dynamics, and kindred sciences, and is a mathematician of marked ability. (C. M.)

RAYMOND, HENRY JARVIS (1820-1869), journalist, was born at Lima, N. Y., Jan. 24, 1820. Brought up on a farm, he graduated at the University of Vermont in 1840 and went to New York city to study law. Coming into contact, however, with Horace Greeley, he began to write for the press, and when the *New York Tribune* was established, in 1841, Raymond was associated in the enterprise. He developed special excellence as a reporter of public addresses and skill in securing important news. Eventually his more conservative character led to some differences with Greeley, and in 1848 he became assistant editor of James Watson Webb's *Courier and Enquirer*. He had already been literary adviser of the publishing firm of Harper Brothers, and to his suggestion the founding of *Harper's Magazine* in 1850 was due. Raymond's activity reached beyond newspapers and periodicals, and in 1849 he was elected to the State Legislature as a Whig. In the next year he was chosen Speaker of the Assembly, and, after a visit to Europe, he determined to establish a newspaper of his own. The *New York Times* accordingly made its first appearance Sept. 18, 1851, and by his wise management speedily won success. Raymond was an anti-slavery Whig, and in the national convention of his party at Baltimore in 1852 he declared the position of the Northern Whigs. Though his party was defeated in the election following, he still had such influence in his State that he was chosen lieutenant-governor in 1854. More than ever determined to resist the aggression of the Southern slaveholders, he assisted in forming the Republican party and drafted the *Address to the People*, issued by its first national convention at Pittsburg in 1856. Its presidential candidate, John C. Fremont, was defeated, and in the next year Raymond declined a renomination as lieutenant-governor. In 1859 he went to Europe, and as a war correspondent accompanied the French army in its campaign in Northern Italy. In the Republican National Convention at Chicago, in 1860, Raymond advocated the nomination of Seward, yet acquiesced in the choice of Lincoln, to whose election he contributed. In 1861 he again became a member and Speaker of the New York Assembly. In 1864 he was prominent in the Republican National Convention at Baltimore, which nominated Pres. Lincoln for a second term. He was then elected to Congress, and in that body, after Andrew Johnson had succeeded to the Presidency, Raymond followed Secretary Seward's example in supporting Johnson's new policy towards the Southern States. In furtherance of this movement a convention was held in Philadelphia in 1866, for which Raymond wrote the *Address and Declaration of Principles*. The movement, however, was a failure, and he resolved thenceforth to confine his energies to journalism. Overwork and, perhaps, disappointment brought his career to a premature end at New York, June 18, 1869. Apart from his contributions to newspapers and periodicals almost his only publication was a *Life of Abraham Lincoln* (1865). See Maverick's *Henry J. Raymond and the New York Press*.

(J. P. L.)

READ, GEORGE (1734-1798), a signer of the Declaration of Independence, was born in Cecil co., Md., Sept. 18, 1733. His father had come from Ireland in 1726 and eventually settled in New Castle co., Del. The son was educated under Rev. Francis Allison and studied law in Philadelphia. Being admitted to the bar, he settled at Newcastle, and in 1763 he was made attorney-general of Delaware. He resigned this office on being chosen a delegate to the Continental Congress in 1774. In 1776, though he did not vote for the passage of the Declaration of Independence, he after-

wards signed it. He also presided at the convention which framed the constitution of Delaware, and in 1777 he became its chief executive on the capture of Pres. McKinley. He was made, in 1782, a judge of the Court of Appeal in admiralty cases. In 1788 he assisted in framing the Federal Constitution, and under it he was elected to the U. S. Senate. At the close of his term in 1793 he was made chief justice of Delaware and held this office till his death, Sept. 21, 1798. His *Life and Correspondence* was published by his grandson, William Thompson Read (Phila., 1870).

READ, THOMAS BUCHANAN (1822-1872), painter and poet, was born in Chester co., Pa., March 12, 1822. At the age of 17 he went to Cincinnati and studied art under the sculptor Clevenger. In 1841 he opened a studio in New York, but soon removed to Boston. His first volume of *Poems* appeared in 1847, and in the next year he edited *The Female Poets of America*. He spent some years in art-study in Rome, and returned to Cincinnati in 1858. *The New Pastoral* (1885), describing the removal of a farmer's family from Pennsylvania to the Mississippi Valley, gives many faithful pictures of American rustic life and scenery. The outbreak of the civil war stimulated Read's genius to the production of *The Waggoner of the Alleghenies* (1862), which was read through the country by the elocutionist, James E. Murdoch, for the benefit of the Sanitary Commission. A shorter but more famous poem, written for Mr. Murdoch, was *Sheridan's Ride* (1864), in illustration of which Read afterwards employed his pencil with success. He died at New York, May 11, 1872.

READING, a city of Pennsylvania, the county-seat of Berks co., is on the Schuylkill River, 58 miles N. W. of Philadelphia, with which it is connected by the Philadelphia and Reading and the Schuylkill Valley Railroads. Fourteen different lines of railroad meet here. The city is regularly laid out, and its site gradually rises to the neighboring hills, which not only afford picturesque views, but give a copious supply of pure water. Besides a court-house and city-hall it has an opera-house, academy of music, public library, 38 churches, a normal, high, and other public and private schools. There are also three national banks, a savings bank, and 5 daily and 12 weekly papers, half of which are in the German language. Reading is largely engaged in iron and steel manufactures of all kinds, rolling-mills, foundries, furnaces, and machine-shops being numerous. There are also manufactures of hats, paper, cigars, cotton-goods, bricks, etc. Reading was settled in 1748, was made a borough in 1783, and a city in 1847. Its population in 1880 was 43,278.

REAGAN, JOHN HENNINGER, statesman, was born in Sevier co., Tenn., Oct. 8, 1818. He received a partial college education but did not graduate. Becoming a lawyer, he went in 1839 to Texas where he was a deputy-surveyor of public lands for four years. In 1847 he was elected to the State Legislature and in 1852 was made judge of a district court. In 1857 he was elected to Congress and in 1861 he was a member of the State Convention which declared the secession of Texas. He was sent as delegate to the provisional Confederate Convention and in March, 1861, was made postmaster-general of the Confederacy. This position he held till the close of the war, being also for a short time acting secretary of the treasury. In 1875 he was a member of the Texas Constitutional Convention and was also elected to Congress, in which he has since served by repeated re-election. He has been a prominent advocate of congressional supervision of inter-State commerce, and the act passed in 1886 substantially embodies the measures which he has long urged.

REAL ESTATE. See PROPERTY.

REAPING MACHINES. See AGRICULTURE, Chap. III.

REBER, FRANZ VON, German art-historian, was

born at Cham, Bavaria, Nov. 10, 1834. He was educated at Munich, and in 1863 was made professor extraordinary and assistant in the Royal Mint-Cabinet. In 1869 he became professor of art-history and aesthetics in the Polytechnic School at Munich. In 1875 the charge of the Royal Galleries was also committed to him. He has published *Die Ruinen Roms und der Campagna* (1863); *Geschichte der Baukunst des Alterthums* (1866); *Kunstgeschichte des Alterthums* (1871), which has been translated into English as the *History of Ancient Art* (1886); *Geschichte der neuern deutschen Kunst* (1876); and *Kunstgeschichte des Mittelalters* (1886). Reber's works are characterized by a comprehensive sympathy with art in all its developments.

RECEIPT in law, as in common language, denotes a written acknowledgment of payment of money or delivery of chattels. It is executed by the person to whom payment or delivery is made. The receipt of one person is, as a general thing, inoperative against another. It must acknowledge the payment or delivery, must be delivered to the debtor, and must be in writing; a memorandum of payment made by the creditor in his own books has been held not to be a receipt. The acknowledgment of payment is presumptive evidence merely, and is not regarded as binding or conclusive. For instance, it may be shown that it was obtained by fraud, or given under a mistake, or that in fact no money was paid as stated. A receipt acknowledging payment "in full" of a specified debt or "of all accounts" or "of all demands" is of a much higher and more conclusive nature. It has been held that an adjustment of the amount due, and a payment of the specified sum as a final satisfaction, may be inferred from such an acknowledgment. Generally speaking, a receipt "in full" is conclusive when the party giving it cannot complain of any misapprehension or fraud with regard to the compromise he was making. Evidence of misrepresentation or fraud in explanation of such a receipt must be clear and full and to the effect that there was not in fact an intended and valid compromise of the demand.

A receipt given under seal, as a general rule, cannot be contradicted. There is an exception to this rule, however, in the case of a receipt for the consideration money, frequently inserted in a deed of real estate. It has been generally held that for the purpose of sustaining the conveyance as against the vendor and those claiming under him, the receipt is conclusive; they are estopped to deny that a consideration was paid sufficient to sustain the conveyance; but in an action for the purchase-money or upon any collateral demand, *e. g.*, to recover a debt paid by the conveyance, or for damages for breach of covenant in the deed, *etc.*, the grantor may show that the consideration was not paid or that an additional consideration was agreed upon, *etc.* A receipt in a deed may also be contradicted or explained on the ground of fraud.

It has been generally held that a receipt embodying a contract is not open to explanation or contradiction as in the case of a simple receipt. For example, a receipt containing an agreement as to the application of the money paid cannot be contradicted by parol evidence inconsistent therewith. The receipt for the goods in a bill of lading, however, may be explained.

(T. R.)

RECEIVERS are assignees of insolvent corporations acting under special directions from a court, and, therefore, not strictly within the laws of bankruptcy. The practice of appointing receivers grew out of the U. S. Bankrupt Laws, which were enacted soon after the civil war and held for about 15 years. In the several States the laws relating to bankruptcy differed materially, and in many of them the practice of appointing receivers has obtained. The State of New York is taken as a leading example of the whole. Previous to 1882 it was not uncommon for savings banks and life-insurance companies suddenly to become insol-

vent, and the expenses of closing them were so long continued and so large that widows and others who could least afford it were deprived of their means of support. The abuse of trusts of that nature became so marked that the Legislature of 1882, through its committees on insurance, made a strict investigation of insurance companies which had been closed within the previous five years. Strict inquiries were made of the insurance department in regard to every insolvent company as a basis of commencing the work. The first law that compelled receivers to report directly to the insurance department (passed in 1867) required the trustees and receivers of such companies not only to make annual statements of their income, *etc.*, but also such other statements as the superintendent of the insurance department might require. Another law, in 1869, extended these provisions to registered policies of life-insurance, and it also provided that the compensation of the receiver should be fixed by the superintendent, and should not exceed 5 per cent. of the total amount of the assets of such company as should come into his possession. In 1873 it was declared that the Supreme Court might appoint a receiver of a fire-insurance company whenever any stockholder had made a formal complaint to the superintendent, and that complaint had been neglected for 10 days. In 1880 a law was passed requiring receivers to file duplicate copies of their reports with the attorney-general or else such receivers might be removed. It was also required that receivers of banking corporations must file duplicates of their reports with the banking department. Early in the investigation of the Assembly Committee it was discovered that the receiver of a savings bank had been paid over \$50,000 for his service in four years, and that the receivers of insurance companies had absorbed an aggregate of \$725,000, and those of savings banks \$1,000,000. Of the 22 broken banks 18, and of the insurance companies 14, were still in the hands of receivers. An application had been made to dissolve the corporation of a leading elevated railroad in New York city; the suit had been discontinued and another suit admitting the legality of the company and declaring its insolvency had been commenced—closely followed by the appointment of receivers. The Committee of the Assembly examined 13 life-insurance companies—one of which may be taken as a specimen of all. This company had absorbed four smaller corporations. In this process not only had the assets of the policy-holders been transferred, but even the rights of the policy-holders had become so confused as to offer but little show of existence. The receiver was supposed to be capable of performing the duties for which he was so largely paid; but his first act was to appoint a "practical man," also at a large salary, to do his work. In defiance of the law which provided that nothing should be drawn out for expenses without an order of the court, this receiver, like most others, drew on the collected fund on his own order. Suits were begun or compromised by him at his own discretion; and the expenses of winding up the 5 companies had aggregated \$175,000 in 5 years—with no prospect of a final settlement. In summing up its report the committee declared that only one of the 13 companies had been managed by the receiver on business principles; that receivers were appointed one after the other—no one appearing to wish the job completed; that the same attorneys frequently appeared as counsel for different insolvent companies. "Interveners" had sprung up to defend the rights of policy-holders, while no such defenders were necessary, because no application could be made to the court by the receiver except upon five days' notice to the attorney-general; and that these interveners, while outwardly defending the policy-holders, were actually in collusion with the receiver and his schemes to grasp more money.

The abuses of receiverships having thus been fully shown, the Legislature of 1883 passed a law providing

that every receiver should be allowed 5 per cent. of the first \$100,000 that he received and paid out; and 2½ per cent. of all sums received and paid out in excess of that sum. It also provided that reports should be made semi-annually instead of quarterly; that the attorney-general should examine the receivers' books at least once in twelve months; and that the affairs of every insolvent corporation then in the hands of a receiver should be closed up within one year from that time unless the court should grant additional time for that purpose; that the attorney-general might, at any time he deemed necessary, take proceedings for the removal of a receiver and the appointment of another in his stead, and any appeal should be made to the general term; that copies of all papers relating to the administration of the trust should be served on the attorney-general; that no receiver should pay any money to any person in any action until the expiration of eight days after a certified copy of the order had been served upon the attorney-general; that all applications to the court should be made in the judicial district where the principal office of the corporation was located—to which district was changed the venue of all actions pending elsewhere; and that legal proceedings in receivership cases should be preferred before all else, on the court calendars, save the cases wherein the plaintiffs are the people of the State. The Attorney-General of New York now has a large share of the responsibility; and the courts no longer decide whether the receiver has been an executor or an administrator *de bonis*. In 1885 the law of 1883 was amended so that every receiver of an insurance, banking, or railroad corporation, or trust company, must present a report every six months to the Supreme Court of the district wherein his trust is located, and must file duplicates with the bank or insurance companies respectively and with the attorney-general showing all the receipts and expenses of his trust. It was also provided that it should not be lawful for any receiver to pay any attorney or counsel until he had stated the amounts to the court as expenses already incurred—such expenses to be approved by the court before being paid to such attorney or counsel. In 1886 a law was passed providing for the winding up of corporations which had been dissolved by legislative enactment. In 1887 it was enacted that no receiver of a life-insurance company should be appointed if such company had actual funds invested of a net cash value equal to its liabilities and a proper reserve fund on policies and claims not matured. (F. G. M.)

RECIPROCITY, COMMERCIAL. This term is used to denote an arrangement between nations allowing specified classes of articles to pass from one to the other free of duty. By the treaty between the United States and Canada made in 1854, natural products of both countries, including agricultural products, animals, lumber, coal, ores, etc., were to be admitted into each country free of duty, and the privilege of fishing in Canadian waters was conceded to the United States. This treaty expired by limitation in 1866. Soon after the expiration of the treaty all the provinces of Canada were formed into a confederation known as the Dominion. The new state had no especial policy in regard to customs; but the increasing expenses of internal improvements compelled the Dominion to seek new methods of meeting them. In 1873 what was known as the Mackenzie (or liberal) government of Canada favored such freedom of trade with the United States as was consistent with levying customs duties on articles produced or manufactured in the country. The proposed treaty was upheld by the Canadian government on the ground that Canadian resources would develop so rapidly that its side of the bargain would be the best. It was contended that Canadian manufacturers did not dread competition with those of the United States, as the Canadians had the advantage of cheaper labor, cheaper machinery, and cheaper materials; that the farming, shipping,

lumbering, and railway interests would all be benefited; and that the almost unlimited water power of Canada ought to turn the scale in favor of the treaty. But the Dominion Board of Trade, supported by the conservative press, strongly opposed the new treaty as disadvantageous to Canadian interests, and the movement failed.

In 1878 a revolutionary wave passed over Canada and swept the Mackenzie government out of power. The Macdonald government returned with authority from the people to construct a protective tariff—a step which was at once taken. The debates in Parliament at the time showed that the object of the tariff was not only to increase the revenue but also to pave the way for a renewal of reciprocity with the United States, or still further for commercial union. The fixing of the Canadian tariff brought on a discussion of the subject with the United States; and the Canadian authorities obtained the consent of Great Britain for the opening of fresh negotiations. The British minister at Washington, Sir Edward Thornton, and Hon. George Brown, a Dominion senator, were accredited as joint plenipotentiaries to negotiate a treaty of fisheries, commerce and navigation with the United States. The result of their labors, in conjunction with Secretary Hamilton Fish, was a treaty draft which was rejected by the U. S. Senate after having been approved by the governments of Great Britain, of the United States, and of Canada. The negotiators on the part of Canada had endeavored to make the new treaty very like that of 1854, but the U. S. government demanded that certain goods said to be common to both countries should be included, and the British negotiators acceded thereto. The list comprised articles imported from the United States to the amount of \$3,000,000 in 1878 and paying a revenue of \$500,000 to the Dominion. This provision was indignantly commented on by a portion of the Canadian press, which declared that reciprocal free trade in natural products had only been obtained "by the sacrifice of the manufacturing interests in addition to the fisheries." Hon. J. A. Garfield, then in the House of Representatives, declared himself, in 1880, in favor of a customs-union because a reciprocity treaty would always be a bone of contention between the political parties, and would not be satisfactory to the whole people.

Since 1885 the discussion of commercial relations with Canada has been revived; but the question has concerned a Commercial union rather than Reciprocity. The suggestion that the relation between the two countries should take the form of the *Zollverein* has received less favor for the reason that, if such a mutual arrangement were made without annexation, the fact would be apparent to all that it would be much more advantageous with annexation, but neither Canada nor the United States appears to be ready to take that step. The renewed discussion culminated in a bill introduced in Congress early in 1887, providing that as soon as the government of Canada should by act of parliament permit all articles of trade and commerce of whatever name or nature, whether the product of the soil or of the waters of the United States, or manufactured articles, live-stock of all kinds and its products, minerals and coal, the produce of the mines of the United States, to enter the ports of the Dominion free of duty, then all articles manufactured in Canada, and all products of the soil and waters, and all minerals and coal, the product of Canadian mines, and all other articles of every name and description produced in Canada, should be permitted to enter the ports of the United States free of duty. This act provided for absolute reciprocity of trade between the two countries as to all articles of whatever name or nature produced in either country. This reciprocity was to go into effect by the proclamation of the President whenever the Canadian Parliament and government had taken similar action, and the secretary

of the treasury with the proper officials of the government of Canada should make the necessary rules and regulations for the purpose of executing the provisions of this act, and at the same time protecting the two governments against the importation of foreign goods through either into the other. This scheme of commercial union proposed that a tariff uniform with that of the United States should be adopted by Canada against the rest of the world; but that between Canada and the United States there should be no tariff at all. The result would be that goods from Great Britain and all foreign countries would be met all over North America by a protective tariff, while the merchandise and manufactures of the United States would have free passage. The present Macdonald government of Canada opposed this Commercial union, and it continues to oppose it although it favors reciprocity. But the opposition (or Mackenzie) party favors the plan and it is sustained by such high authority as Prof. Goldwin Smith and Edward Atkinson. In the Dominion Parliament the scheme was thoroughly discussed early in 1888 and was defeated in April. It has naturally excited less interest in the United States, but it will undoubtedly be revived. (F. G. M.)

RECLUS, JEAN JACQUES ELISÉE, a noted French geographer, was born at Sainte Foy la Grande, Gironde, March 15, 1830, being the second son of a Protestant pastor. He was educated in Rhenish Prussia and at Montauban, and studied geography under Ritter at Berlin. He became familiar with most of the European languages. Leaving France on the establishment of the empire, in 1851, he spent five years in travelling through England, the United States, Central America, and resided for some years further in South America. His travels and researches furnished the subject of many articles in periodicals after his return to France. During the siege of Paris Reclus took part in the balloon observations. He had long held extreme democratic views, and he belonged to the Workingmen's International Association. In March, 1871, he joined the Commune, and on April 5 he was taken prisoner while making a reconnaissance. Although learned men interested themselves in his behalf, he was sentenced to deportation to New Caledonia, but in January, 1872, the sentence was changed to simple banishment. He went to Italy, but afterwards settled in Switzerland, and refused to return to France until complete amnesty was granted to the Communists. Beginning in 1860, with simple guide-books to London and the health resorts of the Mediterranean, he worked his way upward to his work on *La Terre* (2 vols., 1867-68), then his grand, splendidly illustrated work *La Terre et les Hommes* (12 vols., 1875-82). The last has been translated into English by Ravenstein and published both in London and New York under the title *The Earth and Man*. Three brothers of Elisée Reclus have been engaged in similar geographical works, and as many sisters have been active in translating works from German and English.

RECONSTRUCTION. The surrender of the armies of the Confederate States to the army of the United States, in 1865, terminated the active stage of hostilities between the belligerents, but did not fix the conditions of peace between them. By that act the territories of the Confederate States passed under the control of the military power of the United States. A state of war had existed through recognition by Congress, the only authority that could clothe the rebellion of the seceding States with that formal character. Without such recognition, in every act of hostility during the war the people of the Confederate States, so far as they individually took part in it, would have been liable to the penalties for treason against the government of the United States, and as they came under its control might have been subjected to the consequences of that act of treason. But the fact was presented to Congress that the people of those States were under the control of a power that they could

not resist as individuals, and to which the resistance to the authority of the United States was chargeable, and humane sentiment demanded that their governments, rather than their persons, should bear the consequences of accountability. If, however, the state of war was admitted to exist, the necessary implication would be that the seceding States had succeeded in actually separating themselves from political and civil relations to the United States, and were in the actual exercise of independent government over the territories to which that actual power extended, an act of war being necessary to reduce them to their former practical relation to the United States through conquest. Had Congress concluded to continue to treat the resistance of the seceding States as merely an act of rebellion, upon the suppression of that rebellion their status in the Union might have remained unchanged by the fact of that resistance. On the other hand, if a state of war should be properly recognized, that recognition would imply that, for the time being, they were a foreign power, for a state cannot make formal war with itself. With these considerations fully before it, Congress recognized the state of war as existing, and that was equivalent to a declaration that the law and consequences of war should characterize the relations of the parties until the act of making peace should create new relations between them. The laws of war thus displaced, for the time being, all other sources of right and obligation between the contending parties.

The title then by which the United States took military possession of the territories of the Confederate States was that of conquest, under the laws of war, as it had no other proprietary right to such territory. The war as such was directed against the governments of the Confederacy and of the several States composing it, and its proper object was the destruction of that governmental authority as inimical to the Constitution of the United States, and consequently it could be legitimately claimed at the successful termination of the war by the military authority of the United States; and until other methods of government were supplied by Congress, that the military authority was the only legitimate authority within the conquered territories. The action of the government of the United States in dealing with the territories of the Confederate States after the surrender of its armies was distinctly placed upon the principles just stated. It was deemed competent for the military authority to use the mechanism of the existing governments, and its officials found in place, or to change either, and that course was pursued by that authority. According to the principles of general law, recognized by the laws of war, the civil relations of the inhabitants remained unchanged, until modified by the military authority, while the political system that united the people for the purposes of government was for the time being dissolved. The military government of the territories of the former Confederate States was developed in accordance with the principles already stated, and continued to be actually exercised, although with diminishing rigor, until displaced by the State governments erected under the acts of reconstruction enacted by Congress.

The question of the restoration of civil and political order was one of great complexity and difficulty, and gave rise to grave dissensions that ultimately brought the President and Congress into conflict. There were two theories of the relative attitude of the Confederate and Constitutional States, one of which treated the former as unchanged in their relations to the Constitution by the facts of secession, war, and conquest, and the other regarded them as having placed themselves beyond the protection of the Constitution and as in a condition to be dealt with as in the case of other Territories of the United States.

Pres. Andrew Johnson, who had succeeded Pres. Lincoln at his death by assassination at the close of the war, entertained the view first stated. He regarded the States that had attempted secession as of

right in their former constitutional relations from the moment that their capacity to resist the laws of the United States was destroyed. Without authority derived from Congress for that purpose, he assumed to appoint provisional governors for the States recovered from secession. No provision existed in the laws of the United States for the appointment of such officers. All offices, according to the Constitution and laws of the United States, are created by Congress, where not previously created by the Constitution itself. The President has the power to fill the non-elective offices of the government, but subject to the approval of the United States Senate. No such office as a provisional governor of any Territory was provided for by law, and the appointment of officers for the States was clearly beyond the competency of the President. The appointment was made without the approval of the Senate, and before Congress had acted upon terms of pacification and restoration with the States that had been reduced by the military power of the government.

There were but two modes in which a state of war could be converted into one of pacific relationship—the one by the treaty-making power and the other by Congress—and neither of these modes had been applied by the President, for the former depended upon the assent of the Senate and the latter upon the action of Congress, and neither of these forms of assent had been given. If it be assumed that the treaty-making power can conclude conditions of peace independently of the legislative authority, which is alone competent under the Constitution to legalize the state of war, still it was properly claimed that such power was inapplicable to the case in hand, for although the Confederate States were for the purposes of war regarded as a foreign power still at the termination of hostilities, by the actual reduction of these States under the authority of the United States, this limited recognition could have no effect, and the question was simply one of dealing with territories acquired by conquest, which was rightfully claimed by Congress.

Under authority derived from the President alone, the provisional governors assumed to call upon the people of the States under military authority to send delegates to enact constitutions of government for such States. This power was regarded by Congress as being peculiarly within the scope of the legislative authority, and its exercise by an executive officer, without the authority or aid of the proper legislative body, as without precedent in this country. As the absence of a proper legislative authority within these States prevented the exercise of that power, Congress remained to be appealed to, and if the exigency demanded it, could have been convened for that purpose.

Conventions were held and the ordinances of secession were repealed and slavery abolished. In most of the States in which such conventions were held constitutions were framed, some of which were submitted to the people for ratification, while others took effect from the authority of the convention alone. The people who had been emancipated from slavery took no part in these conventions, nor were permitted so to do, notwithstanding they constituted a majority of the population of several of the States. Had the conventions been called in the manner provided by the previous constitutions of the various States so as to be affected by the provisions of such constitutions, the exclusion of the people of African descent could have been accounted for, but such was not the case. The conventions had no sanction under the antecedent constitutions, and if called in the manner attempted in the present instance during the vigor of those constitutions would have been considered irregular and revolutionary. They were in fact original efforts to construct a government unfettered by antecedent authority, and in accordance with American principles of government should have proceeded from the whole population. By these various constitutions the qualifications of the

elector were that he should be a free white person 21 years of age. The emancipated slaves were ignored and no political status given to them under those systems. Under these constitutions governments were organized and public officers chosen, and, but for the presence and unwillingness of the military authority to relinquish the duties imposed upon it until relieved by Congress, they would have gone into complete operation. The strange spectacle was exhibited of a complete civil system, organized under the authority of the national executive, suppressed by the military authority of which its author was the head and source.

The conflict was soon to be transferred, from the ground where an irregular civil authority was seeking to assert itself against the strong military arm, to Congress. Pres. Johnson in his annual message to Congress in 1866, after referring to the constitutional duties of the States, says, as follows: "But if any State neglects or refuses to perform its offices there is more need that the general government should maintain all its authority and as soon as practicable resume the execution of its functions. On this principle I have acted and have gradually and gently and by almost imperceptible steps sought to restore the rightful energy of the general government and of the States. To that end provisional governors have been appointed for the States, conventions called, governors elected, Legislatures assembled, and Senators and Representatives chosen to the Congress of the United States." Pres. Johnson in his message recognized the right of Congress to determine the qualifications of its members.

Both branches of Congress were by large majorities united in opinion and hostile to the method of reconstruction actually in course of execution under the authority of the President. In the first place the action of the President was regarded as an excessive exercise of the powers of his office and as an encroachment upon the authority properly belonging to Congress. Congress claimed to be the only constitutional power that could change the relations between the late belligerents from that which was brought about by the recognition of a state of war to one of political and civil restoration, and was resolved to sustain its proper authority against such encroachment. In the second place Congress deemed it just and wise that the conditions of reunion should be adjusted to the nature of the action that had broken the unity between the States, so as to express the true principles on which that union was based, and that such expression should not be confined to words but should appear in appropriate public action that should transmit to history the lessons of the war. It was thought that the mildest form in which, in the terms of pacification, the estimation by Congress of the wrong inflicted upon the nation could be appropriately expressed would be to disqualify certain of the leaders of secession from resuming their former political influence over the people of those States for such time as Congress should deem just and expedient. In the last place Congress recognized the fact that a large population existed in those States that had attempted secession having neither political nor civil status under the former laws of those States, and who, through the operations of the war, had been made freemen, and had the right to look to Congress to secure to them the proper consequences of freedom in the future constitutions of the civil society of which they should form a part.

In addition to these responsibilities to the Constitution, to the perpetuity of the Union, and to the persons whose condition had been radically changed by the eventualities of the war, there was another consideration of importance that affected the political balance in Congress itself. Should the former slave population be excluded from political participation in their respective States so that public authority

would remain exclusively in a portion of the population of those States, it was a vital political question whether the representation in the House of Representatives from such States should be accepted on the basis of the entire population of those States, or be limited to that portion of the population that was admitted to participation in its public authority. To accept representation on the basis of a population of which a large part was excluded from political authority was regarded as allowing disproportionate advantages as resulting from principles that were regarded by the remaining States as inconsistent with popular government.

The first practical action demanded of Congress by the attitude of affairs was to determine whether persons claiming to have been elected as senators and representatives under the constitutions deriving their authority from the action of the President should be admitted to those bodies. The power of Congress to determine the qualifications of its members was constitutional and undoubted and was conceded by the President. In the present case the exclusion of such persons as claimed election by the recently constituted States to representation in Congress was dependent upon the question whether the constitutions under which they claimed election were authoritative, for unless wanting in validity their right could not be properly denied. If the authority of Congress was needed to enable these States to recover their former places in the Union, it was equally needed to enable them to establish domestic government, for that government could only be habilitated as an integral part of the Union.

Acting upon these principles Congress excluded the representatives from those States and thus in effect declared that the method of reconstruction that had originated with the President was inconsistent with the Constitution. It became necessary then for Congress to initiate a plan for restoring those States to the Union and to prescribe the conditions of such restoration. Fundamental to such action was the question whether the States that had attempted secession were to be regarded as having deprived themselves of the constitutional rights common to the States of the Union in view of the concession that they could not without the consent of the remaining States escape from the obligations incident to such constitutional relationship. If it was possible for a State by denying its obligations to the Union to deprive itself of its rights under that Union, very clearly such a case had been presented in the act of secession and the inauguration of war against the United States. If the seceding States had lost their rights under the Union while their obligations remained unchanged, either the performance of an act of justice or the consent of the aggrieved party was essential to the restoration of such rights. If, however, the opposite view was taken that the States could not by any act deprive themselves of their rights under the Union, even though an act of secession and war intervened, then their independent right to reorganize their internal governments in their own way and to claim representation in Congress unconditionally could not be denied.

Congress was divided upon these questions, for although a great majority of both houses concurred in the view that these States had forfeited their constitutional rights without evading their constitutional obligations, yet a small but energetic minority maintained the opposite doctrine and were unrestricted in its expression. The position assumed in support of the action of the President and the right of representation of the persons elected under this authority was that it was impossible for a State to deprive itself of its status in the Union, whatever might be its conduct or hostility to the Union, and consequently that at the instant resistance to the Union ceased it was in a condition to assume all its rights and functions under the Constitution without any new condition being added to its ob-

ligations. This doctrine was opposed as having no sanction in the principles applied to either individuals or States, and in fact as subversive of the fundamental principles of justice according to which, as universally accepted, a legal relation may exist, and yet, through the conduct of those affected by it, be deprived of all its proper fruits and consequences, only to be restored on such conditions as are agreeable to justice or acceptable to the parties affected by its negation. It was contended that the principles of justice not only demanded compensation for repudiated obligations, but, as applied to vital relationship, such as government, demanded security for the future observance of such obligations, and that Congress could alone determine the character of the security demanded and include it in the conditions of restoration.

With a singular fatuity that often appears in the conduct of men and communities it was contended now, by those who had held to the right of a dissatisfied State to retire from the Union, that such secession was an impossibility, according to the nature of that Union, thus conferring upon rights a quality that only belongs to obligations, and ignoring the fact that the former are dependent on the facts of conduct, while the latter persist until dissolved by the act of those entitled to their benefit.

The conclusion to which Congress arrived as to its right to ascertain the conditions upon which restoration should depend opened for discussion the question of its proper terms and conditions. The prevailing opinion in Congress was that for some indefinite time some of the persons who had been most actively engaged in hostility to the Union should be excluded from participating in the exercise of public authority, Congress to retain in its own hands the authority to terminate this exclusion when in its judgment demanded by the public interest. This temporary expedient appeared to the majority in Congress to be called for both upon grounds of justice and prudence. War had been waged against the United States by a portion of its citizens, and the very question submitted to the arbitration of arms was whether that act of war was an act of treason against the United States. One party claimed that it was in the exercise of a right inherent in the conditions of the Union that was unjustly resisted, while the other party insisted that the act was in violation of the allegiance due to the United States, and as such, taking the form of war, was an act of treason against that government. The acknowledgment of the existence of belligerent relations, if it did not legally shield the actors in rebellion from the consequences of an act of treason as to acts done after that recognition, had that effect practically. The termination of the war established the view entertained by the Union and upon which it was conducted, and left those who participated in hostility against the Union in the attitude of having violated their allegiance to the United States. The question of the sincerity of the convictions of those engaged in the war in opposition to the Union being one of morals, could not enter into the legal and practical solution. To restore at once and without probation those whom the war had placed in this attitude to the exercise of the highest public authority of the nation seemed to the majority in Congress as equivalent to a declaration that either the violation of allegiance to the United States was not an act deserving of severe condemnation, or that the surrender of the armies in the field was an act that obliterated the consequences and the memory of past actions and conferred a new civil quality upon those by whom it had been performed.

The majority in Congress also hesitated to commit the people who had been raised from the condition of slaves through the eventualities of a war brought on by the desire to hold them in perpetual slavery to those who had sought to destroy the Union for the sake of perpetuating their slavery. The majority regarded Congress as bound by every consideration of

duty to those who had received freedom through the consequences of war to make provision for their future welfare as far as could be consistently done in the dispositions relative to reconstruction. The responsibility of having removed from the interested protection of private owners some four millions of people, separated widely from the residue of the population by race and condition, could produce no other effect upon Congress. The future of these people, in view of their great numbers and the absence of the conditions for unitizing them with the surrounding populations in a homogeneous society, presented a problem of the greatest gravity. It was apparent that little consideration had been given in the States that had undertaken their own reconstruction under the presidential auspices to this important subject, for the constitutions that they had framed confined the electoral rights to free white persons and ignored the existence of a vast population without political recognition. The American people had not faced the problem of such exclusion from political right on a scale of magnitude that challenged attention to the principles involved, and were for the most part habituated to the practice of giving to all of domestic birth who mingled in their populations electoral privileges as essential to the protection of individual liberty, and had most liberally extended that right to foreign-born persons seeking their communities.

Notwithstanding the conferring of political as well as civil privileges upon the emancipated slaves was the natural outcome of American doctrine and practice, yet Congress felt the gravity of the question of conferring political rights upon the vast body of emancipated slaves before they were prepared to intelligently exercise such privileges, and felt disposed to leave the solution of that problem by gradual steps to the States most immediately interested in the results of such policy, but under conditions that would be likely to induce a liberal exercise of the power of extending the elective franchise to these people. The Southern States had always placed a high estimate upon the value of a full representation in the national House of Representatives, and had in the framing of the Constitution of the United States secured a provision by which five slaves were to be enumerated as the equivalent of three free white persons in the basis of computing the extent of their rights to representation. It appeared to the majority in Congress that if the representation in Congress of the States undergoing reconstruction was limited in proportion to the exclusion from electoral rights of portions of their populations on the ground of race and former condition of slavery, that a sufficient motive would arise out of the desire for increased representation in Congress to induce a liberal treatment of the question of conferring political rights upon the emancipated slaves. The policy just indicated was finally embodied in Amendment XIV. to the Constitution.

This amendment, proposed by Congress on June 16, 1866, declared as citizens all persons born or naturalized in the United States, and prohibited the States from depriving any person of life, liberty, or property without due process of law, or denying to any person within their jurisdiction the equal protection of the laws. It declared that representatives should be apportioned, counting the whole number of persons in each State, excluding Indians not taxed. It provided that where the right to vote for any office of the United States or a State was denied to any male inhabitant, except for participation in rebellion or other crime, the basis of representation should be reduced in proportion to the number of such excluded citizens to the whole number of male citizens of 21 years of age in such State. It declared that no person shall be a Senator or Representative in Congress, or elector of President or Vice-President, or hold any office, civil or military, under the United States, or under any State, who having previously taken an oath, as a member of

Congress, or as an officer of the United States, or as a member of any State Legislature, or as an executive or judicial officer of any State, to support the Constitution of the United States, shall have engaged in insurrection or rebellion against the same or given aid and comfort to the enemies thereof. It also validated the public debt of the United States and excluded the payment of claims on account of the rebellion or for the emancipation of slaves.

This amendment was intended and proposed as a final act of pacification and restoration, which, if ratified by the requisite number of States so as to become part of the Constitution of the United States, would leave to the States that had participated in the rebellion entire freedom in constructing their domestic governments. As it regarded the civil rights of the emancipated slaves it went no further than the constitutions adopted by those States under the call of their provisional governors had gone. As it regarded the political rights of the emancipated slaves, all was left to the discretion of the States under the influence of the motive to liberality arising from the opportunity of enlarging their representation in Congress by conferring electoral rights upon the former slaves. The exclusion of those who had participated in the rebellion was limited to those who had held official positions in the United States and in the States, and who were presumably of leading influence in the States, and had had the advantages of official position to enhance that influence, and thus were to some extent responsible for the public policy of the States that led them into rebellion. But these exclusions could be removed by Congress, and, as the sequel will show, were intended to be removed by Congress as soon as the main objects of reconstruction should be accomplished. The remaining provisions of the amendment were such as were to be anticipated under the circumstances.

The amendment was promptly rejected by Georgia and North and South Carolina and ratification withheld in all the other States participating in the rebellion, except Tennessee, which promptly ratified it. It was thus evident that the States directly affected by the provisions of the Fourteenth Amendment would not accept the tender made by Congress and that some other course of action was a necessity of the case.

It is necessary here to refer to legislative action that both preceded and followed the discovery that nearly all the States that constituted the Confederacy were unwilling to assent to the terms of pacification and reconstruction propounded by Congress. By an act passed April 9, 1866, Congress ascertained the civil status of the emancipated slaves, declaring that all persons born in the United States, not subject to any foreign power, other than Indians not taxed, were citizens of the United States entitled to the equal protection of the laws. Authority was conferred upon the judiciary of the United States to enforce the rights thus recognized. This act was the first instance in which the national legislature gave effect to the declaration that permeates all the utterances of fundamental truths that have been accepted as the basis of our national system, that "All men are born free and equal," a form of expression that would have been more exact if the statement had been that all men are born to be free and equal. But this declaration was only the partial embodiment of this fundamental truth, for it extended only to the civil status of American-born persons and left the political status still lacking in homogeneity, and was subject to the doubt whether its provisions could extend beyond the States actually reduced by the arms of the United States.

Amendment XIII. to the Constitution, that abolishes slavery within the United States, had previously been proposed to the States and was proclaimed as ratified Dec. 18, 1865, but did not have the effect to ascertain the civil status of the emancipated slaves, although it dissolved all subsisting relations of master

and slave throughout the United States. The declaration of equality of civil right to all native-born persons, as made by Congress, was of limited effect and could be unmade at any subsequent time by the same authority, and hence it was necessary, in order to place it upon an enduring basis, that it should become part of the Constitution of the United States. In part for the accomplishment of this object Amendment XIV. to the Constitution, which has already been dissensted, was passed for submission to the States in June, 1866. As already stated, Tennessee was the only State of those that participated in the rebellion that promptly ratified this amendment, and thus having accepted the terms of pacification and reconstruction tendered by Congress, was, on July 24, 1866, by a resolution of Congress, admitted to its former place in the Union and to representation in Congress.

Congress having thus definitely fixed the terms upon which States and individuals who had participated in the rebellion should be admitted to full privileges under the Constitution, and deeming it wise to place beyond the executive authority any alteration of or interference with these terms, withdrew from the President power conferred upon him in 1862, enabling him by proclamation to extend to persons who had participated in the rebellion pardon and amnesty. A failure of all the States that had formed the Confederate government, except Tennessee, to accept the terms of pacification and reconstruction tendered by Amendment XIV. was, in the judgment of Congress, ground for placing those States under some definite régime. What civil authority existed in them was in the form in which it was placed by the constitutions adopted under the sanction of the provisional governors, while the actual governmental control was in the hands of the military authority of the United States, notwithstanding such civil authority as existed in those States was there under the sanction of the President, and the military establishment by which that civil authority had been practically displaced was under the supreme control of the President. To solve this conflict of jurisdiction, Congress on March 23, 1867, passed an act to provide for the government of the rebel States.

This act declares that no legal governments existed in Virginia, North Carolina, South Carolina, Georgia, Mississippi, Alabama, Louisiana, Florida, Texas, and Arkansas. It divides those States into military districts and provides for the assignment of military officers to their command, placing them under the military authority. The military authority was to extend to the protection of rights of person and property, the suppression of insurrection, disorders, and violence, and to the punishment of disturbers of the public peace. Military courts were authorized and all interference by State authority declared null and void. Authority was conferred upon the enumerated States to form constitutions and choose Senators and Representatives in Congress, and it was declared that such States should be readmitted to the Union and their Senators and Representatives to seats in Congress, when certain conditions should be complied with. These conditions were as follows: The constitution should conform to the Constitution of the United States; it should be framed by delegates chosen by a majority of the votes of the people of the States having the electoral qualifications prescribed by that act; it should be ratified by the same authority; it should be approved by Congress; that no person excluded from office by Amendment XIV. should be eligible as member of the convention to form such constitution or vote for the same or hold office thereunder; that such State should ratify Amendment XIV.; that the admission of the State and of its Senators and Representatives to seats in Congress should take effect when that amendment should be ratified and become part of the Constitution of the United States. The qualification of voters prescribed in the act were that all male citizens of 21 years of age and upwards, of

whatever color or previous condition, who had resided one year in the State, should be entitled to vote, except where disqualified for participation in rebellion or for felony at common law. The act further declared all civil authority within the State prior to admission provisional and subject to the military authority.

By the act just mentioned Virginia constituted the First Military District, North and South Carolina the Second, Georgia, Alabama, and Florida the Third, Mississippi and Arkansas the Fourth, and Louisiana and Texas the Fifth Military District. The President assigned to the command of the respective military districts, Maj.-Gen. J. M. Schofield to the First, Maj.-Gen. D. E. Sickles to the Second, Maj.-Gen. G. H. Thomas to the Third, Maj.-Gen. E. O. C. Ord to the Fourth, and Maj.-Gen. P. H. Sheridan to the Fifth. Maj.-Gen. Thomas was at his own request, on the 15th of March, 1867, relieved from the command of the Third Military District and Maj.-Gen. John Pope assigned to that command.

The second proposed measure of pacification and reconstruction was distinctly made to the enumerated States and was rejected, or rather wholly neglected. As the former action by Congress had established the evil status of the emancipated slave, at least in all those States that by engaging in rebellion had lost the immunities secured by the Constitution, the last-mentioned measure sought by the voluntary acceptance of those States to place his political status on terms of equality with all other citizens of the United States. The plan of leaving the definition of those political rights to the interested States under the influence of a motive that might lead them to deal liberally with it having failed, the solution of that grave question was placed distinctly upon Congress. Seldom in the history of nations has so grave a responsibility fallen to the lot of a legislative body. It has been assumed from the foundation of the government that all native-born male persons subject to the authority of the United States as citizens thereof, except such as were held in legal slavery, were, unless affected by crime, entitled to equal participation in the exercise of all civil and political rights. This conclusion was derived from principles that were regarded as fundamental to our system of government, and were declared in all our constitutions and public utterances. The fact that if the slave was emancipated citizenship and electoral privilege would be necessarily conceded to him was one of the arguments against emancipation. That contingency had occurred, the slave having been emancipated, and the question was pressed home upon Congress whether any just ground existed for excluding the emancipated slave from that which under our institutions was the logical and reasonable consequence of his emancipation. Was it sufficient to say that it might tend to public inconvenience in some of the States that had fostered the institution of slavery to such an extent that the majorities of their populations were emancipated slaves? If the white citizens should be in the majority, the anticipated difficulty would not be serious; if, on the other hand, the emancipated slaves constituted the majority of those populations, the question of expediency was confronted with one of principle, whether on grounds of inconvenience the majority may be consistently disfranchised to relieve the minority from inconvenience. Such had never been the practice of our country and the case was a new one. If Congress, having the power to fix the political status of the emancipated slave, should, after removing from him the protection afforded by the interested protection of the slave system, decline to extend to him the equal protection of the laws, its only answer to the question as to the reason of such course would have to be either that the emancipated slave was uninformed and unskilled in the art of life and government or that he was an African. The first of these responses would contradict the principles on which popular governments are founded, while the latter would be accepted by no en-

lightened people on earth. Congress was confronted by the fact that the former owners of these people, to whose grace they would be committed in the event that political rights were denied them by Congress, were unwillingly deprived of their slaves by the eventualities of a war waged for the very purpose of perpetuating the condition of slavery, and regarded that deprivation as an act of great injustice. As their former masters held that the rights in society that appertain to the white man have no application to the black man, Congress hesitated to assent to surrender the career of those upon whom it had conferred liberty as their due according to the same principles that form the title to the white man to liberty, to those who held opinions and sentiments diametrically opposite to these. In view of the considerations of State prudence respected by all governments Congress hesitated to disfranchise a population that had every motive to be loyal to the nation as the author of their liberty, and to commit the reins of government to those exclusively who sought the dismemberment of the nation. It has been said that on grounds of expediency Congress erred in the judgment that produced these measures of reconstruction, but the important question is whether the consideration of expediency was open to Congress in a case where the principles of liberty were at stake, and where it had placed itself in an attitude to the emancipated slave that implied a large measure of governmental protection to his condition, present and future. The solution offered by Congress to the grave questions thus presented was sustained by the opinion of the great majority of the people of the loyal States, and whatever may be said of the expediency of its policy will command respect for its sincerity of purpose and justice.

The failure of the former slave States to accept the terms thus offered called for further action on the part of Congress, and the acts known as the Reconstruction Acts of Congress were passed, the first upon March 23, and the second on July 19, 1867. The first of these acts was a modification of the previous act providing for the government of the rebel States. It provided for a registration to be made in each of the States there enumerated under the authority of the military officers assigned to them, which should include the emancipated slaves with all other classes, excepting only such persons as had been disfranchised by previous acts. As the exact bearing of this act upon disfranchisements on the ground of aiding in the rebellion was in doubt, the second act of reconstruction was passed to remove such doubt. The persons excluded for participating in the rebellion were declared to be persons who, having been members of the Legislatures or of the executive or judiciary of any of these States, had engaged in the rebellion, whether such complicity arose while holding such offices or at a later time.

Under these reconstruction acts registration of the voters of those States who possessed the requisite qualifications was made; elections were called for the choice of delegates to conventions to frame constitutions for such States; conventions were held and constitutions framed that were submitted to the vote of the people of the States who had the proper qualifications as voters and were ratified. The State offices were filled by election, the Legislatures convened, and the governments were placed in operation. The new State governments promptly adopted Amendment XIV. and at once were admitted to representation in Congress.

During the proceedings in the Second Military District under the acts of reconstruction, Gen. Sickles was relieved in August, 1867, and Maj.-Gen. E. R. S. Canby assigned to the command. In December of that year Gen. Pope was relieved from the command of the Third Military District and Maj.-Gen. G. G. Meade assigned to that command. On July 28, 1868, the military government of the Second and Third Military Districts was terminated, the States composing those

districts having fully complied with the acts of reconstruction. Gen. Schofield was relieved in 1868 from the command of the First Military District, having been made Secretary of War, and Maj.-Gen. G. Stoneman assigned to that command. Virginia, which constituted that district, was not admitted to the Union until 1870. A constitution, formed at Alexandria in 1864 by delegates that were within the military lines of the United States, had not been submitted to the people for ratification. A constitution was framed in 1868 under the acts of reconstruction, but was not submitted to the people until July, 1869, a special act of Congress having been passed for that purpose in April, 1869, when it was ratified and the State admitted in 1870.

Gen. Ord was relieved in December, 1867, from the command of the Fourth Military District, and Maj.-Gen. I. McDowell assigned to that command. Gen. McDowell was relieved in June, 1868, and Maj.-Gen. A. C. Gillem assigned to that command. Mississippi, one of the States of this district, ratified the constitution framed under the reconstruction acts in December, 1868, that constitution having been previously submitted to the people in June of that same year and rejected. Prior to the ratification by Mississippi Arkansas, also in that military district, had ratified her constitution.

Gen. Sheridan was in August, 1867, relieved from the command of the Fifth Military District and the command at first assigned to Maj.-Gen. G. H. Thomas, but soon after to Maj.-Gen. W. S. Hancock. The latter was relieved in March, 1868, and was succeeded by Maj.-Gen. J. J. Reynolds. Louisiana, one of the States of this district, ratified the constitution passed under the reconstruction acts in August, 1868. In July of that year the Fifth Military District was confined to Texas, under the command of Gen. Reynolds. This State finally ratified its constitution in March, 1869, and was readmitted to the Union in March, 1870.

It will be observed that by the final conclusion of Congress the disfranchisement within the States on the ground of participating in rebellion was limited to the case of those who had held office under the United States or in any of those States and while holding such office or afterwards had engaged in the rebellion. The mere fact that a citizen of those States had taken part in the rebellion, even if that part was an important and conspicuous one, did not produce disfranchisement. The class thus temporarily separated from a controlling influence over the new State governments were presumably those who in former years had shaped the policy of the State, and were the responsible authors of the attempt to destroy the Union of the States. To select them personally would have been invidious and might, from erroneous information, have worked injustice in individual cases. To place them in a numerous class that would necessarily include the active agents of rebellion seemed to Congress to be the only mode of distinguishing between the authors of secession and those who had followed them, whether voluntarily or by compulsion, that was not open to serious objection.

The Congressional reconstruction had the effect to write into the constitutions of the States upon which it acted the language of liberty and equality as it had been framed through the revolutions of England and perfected in America, and thus to exhibit an entire unity in the principles upon which government was administered among all the States of the Union. That Congress did not intend that the consequences of rebellion should be perpetuated in the disfranchisement of those engaged in it beyond what appeared to that body to be necessary to give to the new governments of the former slave States principles and forms in harmony with the general institutions of the country was abundantly evidenced by the readiness and rapidity with which the disfranchised were relieved from their disabilities after the habilitation of the States.

See Wilson's *History of Reconstruction, 1865-1868*; McPherson's *History of Reconstruction, 1865-1870*. In this work see SLAVERY, SECESSION, and CONFEDERATE STATES. For discussion of the constitutional questions involved in Reconstruction, see Bishop's *Criminal Law* (4th ed., vol. 2, sec. 1224 *il. note*). (A. J. W.)

REDFIELD, ISAAC FLETCHER (1804-1876), jurist and author, was born in Wethersfield, Vt., April 10, 1804. After graduating at Dartmouth College in 1825, he became a lawyer at Derby, and afterwards at Windsor, Vt. In 1835 he was made a judge of the Supreme Court, and in 1852 became chief-justice. In 1858 he was appointed professor of medical jurisprudence in Dartmouth College. In 1861 he removed to Boston and in 1867 was sent by Secretary Seward to Europe as special counsel to recover for the U. S. government the property of various kinds which had been held in the name or on behalf of the Southern Confederacy. Two years were spent in this work, with profitable results to the government. Judge Redfield died at Boston, March, 1876. His chief publications are *The Law of Railways* (1857); *The Law of Wills* (3 vols., 1861); *The Law of Carriers and Bailment* (1869); *Leading American Railway Cases* (2 vols., 1870). He was also one of the editors of the *American Law Register*, and edited several standard legal works.

REDGRAVE, RICHARD, English painter, was born in London, April 30, 1804. In his youth he was employed in making designs for his father, who was a manufacturer, but in 1826 he began to study at the Royal Academy. His first success was a picture exhibited at the British Institution, *Gulliver on the Farmer's Table*. In 1838 his merit was first recognized by the Academy when he exhibited *Ellen Orford*, and in 1840 he was elected an associate. Among his works in the succeeding years were, *The Poor Teacher*; *The Seampstress*; *The Governess*; *Sunday Morning*. In 1846 he turned more to landscapes and exhibited *Happy Sheep*; *The Evelyn Woods* (1850); *The Forest Portal* (1853); *An Old English Homestead* (1854). In 1851 he was elected an academician, and in that year exhibited *The Flight into Egypt*. He joined with Henry Cole (*q. v.*) in forming a museum of ornamental art, which eventually was enlarged into the South Kensington Museum. He had charge of the display of British art in the Paris Exhibition of 1855, and a few years later was made by Queen Victoria surveyor of crown pictures, which position he held twenty-two years, resigning in 1880. Among his pictures produced in this period are *Startled Foresters* (1874); *Starting for a Holiday* (1875); *Calling the Sheep to Fold* (1876); *Well-spring in the Forest* (1877); *The Heir Come of Age* (1878). He also joined with his brother in preparing *A Century of Painters* (1866), which gives a history of British art since Hogarth.

RED JACKET, or SA-GO-YE-WATHA (1751-1830), Indian chief of the Wolf tribe of the Senecas, was born at Old Castle, near the foot of Seneca Lake, N. Y., in 1751. His Indian name given above means, "He keeps them awake," and was assumed on his attaining the dignity of a sachem. His name "Red Jacket" was derived from a richly embroidered scarlet jacket, the gift of an English officer, which he took great pride in wearing. In youth he was remarkably fleet of foot, and was often employed by his own people, and, during the Revolutionary war, by the British officers on the border as a scout and courier. On the death of Brant (*q. v.*) Red Jacket became the leading man among the Six Nations. In 1781, at a council held at Fort Stanwix to negotiate a treaty for the cession of lands, Red Jacket spoke eloquently in opposition to it, but it was nevertheless ratified. In 1792, on the conclusion of a treaty of peace between the United States and the Six Nations, Washington presented him with a silver medal which he ever after held in high esteem, and which is now

(1889) the property of Gen. Ely S. Parker. In 1809 he gave information to Erastus Granger, the Indian agent, of attempts by Tecumseh to draw the Six Nations into the Western combination, and in 1810 he visited Washington and delivered an eloquent speech on the subject to the Secretary of War. In the war of 1812 his counsel was often of essential service to the American army, in particular on the eve of the battle of Chippewa. In 1829 he passed through New York on his way to Washington, and while in the former city sat for his portrait to Robert W. Weir. Although then in his 78th year he was still hale and vigorous. In his later years he was grossly given to drinking, but was able to restrain himself on great occasions, as before a council. He was implacable in his hostility to Christianity and to missionaries, and despised the white man—his dress, speech, and customs. His character was marked with strange contradictions. Largely destitute of physical courage, he yet possessed tenacity of purpose and great moral resolution. As a statesman he was sagacious; as an orator, of surpassing eloquence. Yet he could descend to the meanest expedients of the demagogue. In all circumstances, however, he was a patriot and loved his nation, whose extinction he prognosticated but strove to avert. His form was tall and erect, his walk dignified, and his oratory, particularly in council, almost majestic. He died at Seneca Village, near Buffalo, N. Y., Jan. 30, 1830. His *Life* has been written by W. L. Stone (1867). (J. H.)

REDPATH, JAMES, journalist, was born at Berwick-in-Tweed, England, in August, 1833. At the age of fifteen he was brought by his parents to the United States. They settled in Michigan, where the son became a printer, and afterwards editor of a newspaper. He was Kansas correspondent for the *New York Tribune* during the troubles connected with the settlement of that State. He afterwards went to Hayti, and on his return acted as emigration agent for the Haytian government. During the civil war he was actively engaged as correspondent, and also exerted himself in behalf of the emancipated slaves. After the war he was superintendent of education at Charleston, S. C., and founded schools and an orphan asylum for colored children. In 1868 he established a lyceum bureau at Boston, and he has since been actively engaged in supplying lectures as well as in journalism. He has published several books relating to different stages of his career, and a *Life of Captain John Brown* (1860).

RED WING, a city of Minnesota, the county-seat of Goodhue co., is on the right bank of the Mississippi River, below the mouth of Cannon River, 41 miles from St. Paul by railroad and 58 by river. It is on a plateau, enclosed by high bluffs. It has a court-house, national bank and other banks, opera-house and music-hall, 15 churches, a high-school and other schools, and 1 daily and 2 weekly newspapers. There are flour-, saw-, and planing-mills, and manufactories of furniture, agricultural implements, wagons, and shoes. In 1880 it had a population of 5876.

REDWOOD. See SEQUOIA.

REED, SIR EDWARD JAMES, English naval architect, was born at Sheerness, Sept. 20, 1830. He was educated at the naval school at Portsmouth, and was afterwards employed in the dockyard at Sheerness. He became editor of the *Mechanics' Magazine*, secretary of the Institution of Naval Architects, and chief constructor of the British navy. He designed several iron-clads, including a frigate for the Turkish navy. He also built steam-transports for India, and numerous smaller vessels. He resigned in 1870, and engaged in private business. He was elected to Parliament in 1874, and represented the Pembroke boroughs until 1880, when he was returned for Cardiff. He had in the meantime visited Japan, at the request of the Imperial government, and on his return published *Japan: Its History, Traditions and Religions* (2 vols.,

1880). During Mr. Gladstone's brief administration in 1886 Sir Edward Reed was Lord of the Treasury. He has been a member of various committees to investigate subjects connected with naval affairs. His works on *Practical Shipbuilding*, *Iron-clad Ships*, and *Coast Defense*, are of high value.

REED, JOSEPH (1741-1785), patriot, was born at Trenton, N. J., August 27, 1741, graduated at Princeton in 1757, and studied law at the Temple, London. In 1767 he was appointed deputy secretary of New Jersey, and while on a visit to England in 1770 he married Esther, daughter of Dennis de Berdt, the agent for Massachusetts. On his return he settled in Philadelphia, and kept up a correspondence with Lord Dartmouth, English Colonial Secretary. He was a member of the committee of correspondence in 1774, and President of the Pennsylvania Convention in 1775. He was elected a delegate to Congress, but accompanied Washington, at his request, to Cambridge, as his secretary. In 1776 he was adjutant-general, and in 1777 was named brigadier-general by Congress, but declined, though he served at Brandywine and other battles as a volunteer. Bancroft, on the strength of a report made by Count Donop in 1776, charges Reed with disaffection to the patriot cause. On the other hand, Reed is reported to have replied to offers from British peace-commissioners: "I am not worth purchasing, but such as I am, the King of Great Britain is not rich enough to buy me." He certainly exposed the misconduct of Benedict Arnold in Philadelphia, and had him brought to trial. He was President of Pennsylvania in 1778, and was active in suppressing the mutiny of the ill-paid soldiers in 1781. He died at Philadelphia, March 6, 1785. Both his grandsons wrote his *Life*, Henry in Sparks's *American Biography*, and William more fully with his *Letters* (2 vols., 1847), in order to vindicate his character against the attacks of Bancroft in his *History of the United States*. The latter defended his position in an essay, *Joseph Reed* (1867).

His grandson, HENRY REED (1808-1854), was born at Philadelphia, July 11, 1808. After graduating at the University of Pennsylvania in 1825, he studied law with John Sergeant, but in 1831 was called to a professorship in his *alma mater*. He was a devoted student of Wordsworth, and edited the first complete American edition of his *Poems*. In 1854 he visited England, and on his return voyage went down at sea in the steamer *Arctic*, Sept. 27, 1854. He had edited various historical and poetical works of English authors. Of his lectures his brother afterwards edited *English Literature* (1855); *English History, Illustrated from Shakespeare* (1856); and *British Poets* (1857).

Another grandson, WILLIAM BRADFORD REED (1806-1876), born June 30, 1806, graduated at the University of Pennsylvania in 1822, and became Attorney-General of Pennsylvania in 1838. After a successful career at the bar, he was sent as minister to China in 1857, and negotiated a treaty with that nation. After his return, he was strongly opposed to the war for the Union, lost his fortune and law practice, and became a journalist. During the civil war he was for a time the American correspondent of the *London Times*. He died at New York, Feb. 18, 1876. Besides various books and pamphlets in defence of his grandfather, he published *World Essays*; *Among My Books*.

REES, ABRAHAM (1743-1825), a British educator and encyclopædist, was born at Llanbrynmair, Wales, in 1743. He was educated for the Presbyterian ministry, and was for over twenty years tutor in the Hoxton academy. In 1768 he was ordained also pastor of a Presbyterian church in Southwark, London, and after holding this post fifteen years, took charge of another congregation. In 1786 he became principal of an academy at Haekney. In that year he completed an edition of Chambers' *Cyclopædia*, on which he had been engaged for ten years. His wide learning and

scientific attainments procured for him fellowship in the Royal Society and the Linnæan Society. In 1802 he commenced the *Cyclopædia* which is known by his name, and completed it in 1819 in 45 volumes. This able work was soon reprinted in Philadelphia. Dr. Rees died June 9, 1825.

REEVE, TAPPING (1744-1823), lawyer, was born at Brookhaven, L. I., October, 1744. He graduated at Princeton College in 1763, and settled at Litchfield, Conn., in 1772. There he practised law and soon had as a student and an inmate of his family Aaron Burr, whose sister he had married. Burr left him for the more adventurous career which the army offered. In 1784, when peace was established, Reeve instituted the Litchfield Law School, whose reputation soon spread to other States. Until 1798 he gave all the instruction himself, but then being made Judge of the Superior Court of Connecticut, he called an assistant to his aid in the school. Reeve held liberal ideas, and was the first lawyer of eminence to urge reform in regard to giving married women control of their property. He published the *Law of Baron and Femme*; *Parent and Child*, *Guardian and Ward* (1816). He died at Litchfield, Dec. 13, 1823. After his death his treatise on the *Law of Descents* appeared.

REFORMATORIES AND REFORMATORY METHODS. The term Reformatory, within the purview of this article, has reference solely to such prisons, or places of detention for persons, convicted of offences against the criminal laws as are set apart for the express purpose of making the reformation of their inmates the main object of their creation.

Reformatories are of three classes: (1) for adult criminals convicted of felonies, of which the reformatory at Elmira, N. Y., is a typical specimen. Any prison may be reformatory in its aims, and all modern prisons, perhaps, have reformation in view more or less, but convict prisons designated as reformatories are such as are specially set apart for the reception of young men convicted of their first offence, and who are considered corrigible by the court in which they are convicted and sentenced.

(2.) For adult criminals convicted of offences less than felony. This class includes houses of correction and workhouses.

(3.) For criminal youth. This class includes all institutions for the care of juvenile offenders convicted of violations of the criminal laws.

Orphan asylums, children's homes, and other institutions for the care of dependent children, who are simply unfortunate and not criminal, are not reformatories any more than Sunday-schools or day-schools, and should not be included in the same category. It is true, children entirely innocent of any criminal conduct are often found in reformatories, but their commitment to such institutions is a wrong which ought not to be permitted. Reformatories are for persons who have attained the age of legal responsibility, and who have been convicted of actual violations of law, and their presence there necessarily imposes a taint which society has no right to impart to such as are innocent or irresponsible, and to do so is to perpetrate a crime against childhood. Institutions for the care of dependent children are of the highest value, and for the prevention of crime their usefulness cannot be exaggerated, but they are not, in any penological sense, reformatories.

The reformation of criminals, whether old or young, as a proper object of governmental action, is an idea of comparatively recent origin. In the treatment of offenders, for the repression of crime, the dominant idea of the world has been deterrence by severity. An eye for an eye; tooth for tooth; life for life, has been the established formula of belief, and to a large extent this idea still prevails, but happily, as Christianity broadened the influence of its teachings, and experience demonstrated the efficiency of its regenerating

power upon the lives of men, it began to dawn upon the minds of legislators that even to prisoners kindness, sometimes, might be better than cruelty. The first reformatory, however, actually established, as such, by governmental action, was the prison of St. Michael at Rome, in 1704, by Pope Clement XI., and was for boys and young men. It was conducted upon a system similar to what is now known as the "Auburn system"—that is to say, of separate cellular imprisonment by night and silent associated labor by day—and its success was conspicuous and continuous. Howard visited it and praised it as one of the few prisons in the world worthy of commendation. He found over the prison door this inscription: "Clement XI., Supreme Pontiff, reared this prison for the reformation and education of criminal youths, to the end that those who, when idle, had been injurious to the state, might, when better instructed and trained, become useful to it." Within the prison, on a marble slab inserted in the wall, he found this (as he terms it) admirable sentence: "It is of little use to restrain criminals by punishment, unless you reform them by education." As a general principle in the care and discipline of young criminals, this golden sentence from Pope Clement XI. must commend itself to all right-thinking people, and in the requirements of modern penology no prison should be tolerated which does not make the reformation of its inmates a leading object. In fact, to discharge a criminal without reformation is to defeat the only object (the protection of society) for which imprisonment is justifiable.

For sixty years St. Michael's prison at Rome found no imitators in its reformatory purpose and methods, but finally, in 1775, another prison, similar in character and purpose, was established at Ghent, which soon became a model for all Europe, and was recommended as such by Howard, who visited it in 1776, and again in 1778. In fact, Howard found at Ghent, in successful application, nearly all the great principles of modern penology. They were: (1) Reformation as a primary end, with hope as a great regenerating force. (2) Industrial labor with a variety of trades to prepare prisoners for self-support. (3) Education, religious and literary. (4) Abbreviation of sentence and a participation in earnings as incentives to diligence, obedience, and self-improvement. (5) The exclusion of cruel bodily inflictions as a means of maintaining discipline, and the enlistment of the will of the criminal in the work of his own moral regeneration. In fact, as a reformatory prison it has rarely been equalled since, and it still remains a noble monument to the genius and humanity of Viscount Vilain XIV., under whose inspiration and influence it was established. Through its example all prisons in Belgium are now distinctively reformatory in purpose and character, and other Continental countries are adopting similar methods.

Under the British government the first prisons conducted on reformatory ideas were those of Ireland, where the system of classification and parole was established by Captain Crofton (now Sir Walter) in 1854, and which is now known as the "Crofton system." (See CROFTON.)

In England, through the legislation of 1877, unifying prisons and centralizing their supervision, the whole prison system has been made reformatory in purpose, and the steady reduction of crime throughout the kingdom clearly indicates its efficiency.

In the United States there are no convict prisons under State care without some reformatory agencies. In all religious services are held upon the Sabbath day, either by a resident chaplain or some clergyman from the outside. In the majority of these prisons flourishing Sunday-schools are maintained, chiefly through the efforts of volunteer workers from outside; and in quite a number weekly prayer-meetings are held, in which the prisoners take an active part. There are also, in some prisons, night-schools, in

which prisoners have some educational opportunities, and probably in all prisons there is some kind of a prison library.

In recent years, however, a few prisons of this class have been organized and specially designated as reformatories, and have for their primary object the reformation of criminals. Of these the New York Reformatory, at Elmira, is the pioneer and most conspicuous example. Prisoners received at Elmira are such as are convicted of their first offence and are under thirty years of age, and are held under what is known as the indefinite or indeterminate sentence.

The prisoners are classified in three grades, and all prisoners enter the second grade, with liability to fall to the third grade for misconduct, or they may rise to the first grade by good conduct. Promotion to the first grade is by earning 3 marks for 6 months in, or nearly in, succession. The marks are earned, 3 for demeanor, 3 for labor, 3 for school progress. After entrance to the first grade, six months more of good performance is required under somewhat enlarged liberties, when, if there is confidence and employment, the inmate may go out on parole. Six months of good record on parole usually secures from the managers an absolute release. Under a similar system of marks the prisoner may fall into the third grade, but by good conduct he may work back into the second grade, and thence to the first, and thence to parole. Each grade has a uniform peculiar to itself, and the prisoners, as they advance, have more privileges and better fare. The average period of detention is about two years and a half. If found incorrigible, the prisoner is transferred to Sing-Sing or Auburn to serve out the maximum of his sentence.

The Elmira Reformatory was established in 1876, and the reported results are that 82 per cent. of the prisoners discharged are thus far reputable and self-supporting citizens.

In view of the apparent superiority of this system, similar reformatories have been recently opened at Concord, Mass., and at Huntingdon, Pa., and others are in process of construction in Ohio, Minnesota, and Kansas, and in several other States similar action is under legislative consideration.

The Reformatory at Concord, Mass., was opened in 1884. Like Elmira, it has three grades and a marking system, by which the prisoner rises or falls, but unlike Elmira, it receives misdemeanants as well as felons, and there is no limit as to age or number of offences, and only a part of the prisoners are subject to the indeterminate sentence. Larger privileges are allowed than at Elmira, and religious influences are made more prominent. Then there are other differences of a minor character, but whether these changes are improvements or not, it is too early yet to determine, but thus far the results are encouraging to the prison authorities.

The prison for women at Sherborn, Mass., established in 1877, is also conducted on a system similar to that at Elmira, although it has four grades instead of three, and its inmates are mainly misdemeanants under definite sentences. It is wholly under the management of women, and as a prison for women it has no superior.

The Ohio Penitentiary, at Columbus, although not a reformatory in name, has adopted the grading and marking system of Elmira, and also maintains night-schools, in which the elementary branches of a common school education are taught. A system of parole has been authorized for the Ohio Penitentiary which is unlike that of any other American prison, and its reformatory influences have been so satisfactory and promising as to deserve special notice.

The law authorizing this was passed May 4, 1885, and provides, Sec. 8, "that said board of managers shall have power to establish rules and regulations under which any prisoner who is now or hereafter may be imprisoned under a sentence other than for murder in the first or second degree, who may have served the

minimum term provided by law for the crime for which he was convicted, and who has not previously been convicted of felony, and served a term in a penal institution, may be allowed to go upon parole outside of the buildings and enclosures, but to remain, while on parole, in the legal custody and under the control of the board, and subject at any time to be taken back within the enclosure of said institution; and full power to enforce such rules and regulations, and to retake and reimprison any convict so upon parole, is hereby conferred upon said board, whose written order, certified by its secretary, shall be sufficient warrant for all officers named therein, to authorize such officer to return to actual custody any conditionally released or paroled prisoner, and it is hereby made the duty of all officers to execute said order the same as ordinary criminal process."

The rules under which this law is operated are as follows:

1. No prisoner shall be paroled who has not been in the first grade, continuously, for a period of at least four months.

2. No prisoner shall be released on parole until satisfactory evidence is furnished to the board of managers, in writing, that employment has been secured for such prisoner from some responsible person, certified to be such by the auditor of the county where such person resides.

3. No prisoner shall be paroled until the managers are satisfied that he will conform to the rules and regulations of his parole.

4. Every paroled prisoner shall be liable to be retaken and again confined within the enclosure of said institution for any reason that shall be satisfactory to the board of managers, and at their sole discretion, and shall remain therein until released by law.

5. It shall require the affirmative vote of at least four (out of five) managers to grant a parole.

The principal requirements of the paroled prisoner are: That he shall refrain from crime; lead an honorable life; conduct himself honestly; avoid evil associations; obey the law; abstain from the use of intoxicating liquors as a beverage, and report monthly by mail to the secretary of the board, for which blanks are furnished.

The following are the tabulated results of the law for the whole period of its operation prior to Jan. 1, 1888:

Number paroled,	302
Number discharged by expiration of sentence,	115
Number discharged by board of managers,	9
Number pardoned by governor,	4
Number whose paroles were revoked,	3
Number violated parole and not returned,	15
Number violated parole and have been returned,	17
Number who have died,	5
Number who refused to accept parole,	1
Number regularly reporting,	133

JUVENILE OFFENDERS.

In the care and reformation of juvenile offenders the United States has kept pace with the best experience of the world. The first reformatory in the world for criminal youth, which became a permanent success, was that established by John Falk, at Weimar, in Germany, in 1813. This was followed in 1816 by another near Düsseldorf, and still another at Berlin in 1819. None of these establishments, however, received their inmates from the courts, nor held them upon legal warrants. The relation was voluntary upon both sides.

To America belongs the credit of establishing the first reformatory in the world for juvenile delinquents, by legislative enactment and under legislative control. This institution, conceived by Edward Livingston, the greatest of American penologists, and fostered by John Griscom, John Eddy, Cadwallader D. Colden, and other distinguished citizens and philanthropists of the city of New York, was authorized by an act of the Legislature of New York March 29, 1824, and has since been known as the New York House of Refuge, and still remains in active and efficient operation.

Its fifth annual report states its powers and purposes as follows: "If a child is found destitute; if abandoned by its parents, or suffered to lead a vicious or vagrant life; or if convicted of any crime, it may be sent to the House of Refuge. There is in no case any other sentence than that it shall 'there be dealt with according to law.' That is, it may, if not released by some legal process, be there detained, if the managers should think it unfit to be sooner discharged, until it arrives at age. Parents or guardians, from the time it is legally sentenced to the refuge, lose all control of its person. When it is believed that a child is reformed, the managers have power, with its consent, to bind it as an apprentice till the age of twenty-one."

The success of this institution was so conspicuous, and its results so beneficent, that similar institutions were soon established elsewhere, until at the present time there are between forty and fifty institutions for juvenile offenders in the United States under State or city supervision, with an average population of over 12,000.

Under the common law of England a child under ten years of age is presumed incapable of crime, and that is the general rule in the United States. In New York, however, the statute provides that "a child of the age of seven years, and under the age of twelve years, is presumed incapable of crime, but the presumption may be removed by proof that he had sufficient capacity to understand the act or neglect charged against him and to know its wrongfulness."

In England the preservation of a child from a criminal record is considered so important that he is rarely sent to a reformatory for a first offence. If he has parents or guardians he is simply reprimanded or birched, for a first offence, or if homeless is cared for in some institution where no taint of crime is imposed, and this treatment in a majority of cases is found entirely sufficient. This method not only saves the child and preserves his self-respect, but it also saves the State from a large expenditure of money.

In Boston, for several years past, a system similar in principle, and applicable not only to minors but to adult misdemeanants also, has been in successful operation for a number of years, and is known as the probation system. It consists in a suspension of sentence, and a release under the supervision of a probation officer, to whom the prisoner reports at stated periods, and by whom he may be recommitted for sentence if he proves delinquent. The results have been so satisfactory that English penologists have recommended its adoption there, and an act for that purpose is now under consideration by the British Parliament.

In American reformatories, for juvenile offenders, the treatment is largely educational, although, as a rule, the inmates are employed at productive labor for the support of the institution at least one-half of the time. In recent years, however, in some institutions, large attention has been given to industrial training, and with very satisfactory results.

The State Industrial School at Rochester, N. Y. (formerly the House of Refuge for juvenile delinquents in Western New York), in 1884 inaugurated a system of industrial training, which has been so enlarged that the institution now is practically a school of technology, and its success has been so great as to attract large attention, and seems likely to mark the beginning of a new era in reformatory management. There are six departments in which trades are fully taught, both theoretically and practically, viz.: (1) carpentry and joinery; (2) wood-turning and pattern-making; (3) black-smithing; (4) lathing, plastering, brick- and stone-laying; (5) moulding; (6) painting.

Capt. Levi S. Fulton, the accomplished superintendent of this institution, after many years' experience in reformatory work, says in his last report: "I would most earnestly recommend to all interested in the management of reform schools or similar institutions that they at once transform their institutions into

schools of technology, where they will not only educate the head but the hands also, and make of their boys skilled workmen at some trade or calling, sending them out equipped to fight life's battle honorably and successfully, and to become self-reliant, self-respecting, and self-sustaining citizens." The increased cost of the technological system, apparently, will not exceed \$30 per annum, per capita.

Reformatories for juvenile delinquents, throughout the United States, compare very favorably with the best in other countries, and in reformatory results have not been excelled anywhere. The annual conferences of those engaged in reformatory work, by affording opportunity for an exchange of experiences, have done much to improve our reformatory institutions, and a steady advance is thus maintained.

In recent years much discussion has been had upon the comparative merits of what is known as the Congregate system, and the Cottage or family system, which has not yet been settled, although the preponderance of opinion, at present, seems to be in favor of the latter. Doubtless both have their merits. The Congregate system is the simplest, and can be managed the easiest by one controlling mind, but it lacks opportunity for a classification of inmates. The Cottage system affords a larger classification, but requires a superior efficiency in the subordinate control of each cottage, which is difficult to secure. Evidently, therefore, more depends upon efficiency of administration than upon the system, and upon the ability to obtain this efficiency this question of superiority must be decided.

Clearly what is needed in all of our American institutions, whether correctional or charitable, is not so much a change of system as a higher efficiency in administration, which can only be obtained by a service based upon intelligence, experience, and integrity, together with a tenure in office which shall not be disturbed by political changes. (R. B.)

REFORMED CHURCH IN AMERICA.—
HISTORICAL SKETCH.—The colonists from the Netherlands established public worship on the island of Manhattan soon after they had made their first permanent settlement. As early as 1626 it was conducted by two "Krankbesoecers" or visitors of the sick. In 1628 a church was organized by the Rev. Jonas Michaelius with about fifty members. He was followed by the Rev. Everardus Bogardus, who was accompanied by the first schoolmaster, Adam Roelandsen. The parochial school then established has continued to the present day. Bogardus married the widow Annetje Janse, whose farm became the valuable litigated property of Trinity Church, New York. The first church building, a small wooden structure, was erected during the ministry of Bogardus on Broad street, between Pearl and Bridge. The second was erected in 1642, during the administration of director Kieft, within the walls of Fort Amsterdam on the Battery. By the articles of surrender in 1664 the ecclesiastical rights possessed by the Dutch at the time were guaranteed to them. They continued in possession of the church in the fort, but courteously allowed the English military chaplains to use it when not occupied by them. After the completion of their new church in Garden street they abandoned the one in the fort, which continued to be used by the English garrison until 1741. At the time of the surrender New Amsterdam contained about 1500 inhabitants, and there were only five churches and six ministers in the whole province of New Netherland. Other churches were subsequently planted in the various settlements in the province. These churches were provided with pastors by the Dutch West India Company and the Classis of Amsterdam, and in a short time they came entirely under the care of that classis. They remained in this state of subordination and without a completely independent organization until the year 1794. This long period was one of struggles with many and great difficulties, and consequently of slow growth.

This body of Christians is at present small among the denominations, and surprise is often expressed that the one that was first on the ground in New York should have fallen so far behind. But little progress could be expected when there was a continuous struggle for life. 1. The surrender to the English had its effect, for it checked immigration and caused it to cease almost entirely, and many persons returned to their original homes; it also gave the advantage of official patronage to the English or Episcopal Church, which became virtually the "Church by law established," as was indeed openly claimed. 2. During this long period of nearly a century and a half the Dutch language was exclusively used in public worship, catechizing, etc., and so growth could not be more rapid than the natural increase of the Dutch population allowed. The door was closed against all English-speaking Calvinists, Scotch and Irish Presbyterians, and Congregationalists. The delay in the introduction of the English language in public worship, which was desired and urged by many, caused numbers of the young people, who were educated in English, to join the Episcopal and Presbyterian Churches; the strife produced by the agitation of the question drove many lovers of peace into other communions, and when at last the English was introduced, the uncompromising opponents of it took their leave and joined the Episcopal and Presbyterian Churches. 3. The lack of independent organization was a serious hindrance; for the final court of appeals in cases of discipline was in the mother country, and all important matters that were here agitated had to be reviewed by the Classis of Amsterdam. 4. The want of institutions for the education and of authority for the ordination of ministers was a great hindrance. Ministers were sent from Holland to supply the American churches, and young men in this country who desired the ministry were sent to the universities of Holland to be educated, and to be there ordained. Differences of opinion on this matter divided the churches into two parties, a progressive and conservative, denominated the *Cœtus* and *Conferentie*, the controversy between whom on the question of ecclesiastical independence and ministerial education brought the church to the brink of ruin. In 1771 these parties were brought together in a convention held in New York, and a "Plan of Union" was adopted to which the ecclesiastical authorities in the Netherlands assented.

In 1794 the "Reformed Church in America" attained to full ecclesiastical independence by the adoption of a constitution embracing the church orders of the Synod of Dort, and articles explanatory of the ways in which they should be applied in this country. In this work of reconciliation and of organization the leader and ruling spirit was Rev. John H. Livingston, D.D., a young man who had a short time before completed his studies at the University of Utrecht, and who was one of the pastors of the Collegiate Reformed Dutch Church of New York city, and who in 1784 was appointed the first professor of theology. The efforts of the church were for a long time chiefly devoted to the establishment of educational institutions for the preparation of young men for the ministry. A charter for Queen's College was obtained in 1766, which, however, on account of some imperfections, never went into effect. A second charter was obtained in 1770 and the college was established at New Brunswick, N. J., where it continues under the name of Rutgers, given to it in 1825. It is in a flourishing condition under the presidency of Merrill E. Gates, LL.D. The theological professorship of Dr. Livingston has been developed into a theological school located at New Brunswick, N. J., with ample buildings and endowments, a corps of five professors, a valuable Biblical Museum, and the Gardner A. Sage Library, containing 40,000 admirably selected volumes, and which is acknowledged by competent judges to be one of the best working theological libraries in the United

States. This school has received for buildings, endowments, and other purposes, from the late James Suydam and Gardner A. Sage, of New York city, the sum of \$500,000. The Reformed Dutch Church was originally confined to the provinces of New York and New Jersey, with the exception of a few churches in Eastern Pennsylvania. While extension was for a long time impracticable, the scattered pastorless churches were well cared for. Some missionary work was done quite early, however, and a few churches were established in Canada which were after a time abandoned. About 1835 churches began to be established in the Western States, and soon a large colony emigrated from the Netherlands under the lead of the Rev. Dr. A. C. Van Raalte, and settled at Holland, Mich., and connected themselves with the Reformed Dutch Church in America. Immigration has continued and many churches using the Hollandish language have been established. The church has made considerable progress farther west, even as far as Dakota. At Holland, Mich., Hope College and the Western Theological Seminary have been established. The Particular Synod of Chicago embraces 104 churches and 78 ministers.

DOCTRINAL STANDARDS.—While this church strongly insists that the word of God is the sole, authoritative, and infallible rule of faith and practice, yet symbols of doctrine have been adopted as expressive of the views entertained of truth, and as bonds of church fellowship. Subscription to these symbols is required of all the ministers. They are—1. The *Belgic Confession*, composed by Guido de Bres, the Belgian martyr, consisting of 37 articles, adopted by the Synod of Antwerp in 1566, and always retained in the Reformed Churches of both the Netherlands and America. 2. The *Heidelberg Catechism*, which was prepared at Heidelberg by Olevianus and Ursinus in 1563 by the order of Frederick III., elector of the Palatinate. This catechism was at once received with great favor by the reformed of every country in Europe, and was translated into many languages. It is an experimental and confessional rather than dogmatical catechism. An abridgment of it, called "A Compendium of the Christian Religion," was made by Rev. H. Faulkelius, of Middleburg, Zeeland, and was adopted by the Synod of Dort as a manual for the instruction of candidates for the Lord's Supper. 3. The *Canons of the Synod of Dordrecht*. These were adopted in 1619, and are explanatory of the statements of the confession of faith and catechism, touching the five points in controversy between the Remonstrants and Contra-Remonstrants, or Arminians and Calvinists, and are condemnatory of the views of the former. The doctrinal system of the Reformed Church in America may be designated as Calvinism of the moderate, infra-lapsarian type of the Synod of Dordrecht.

FORM OF GOVERNMENT.—This is Presbyterian, that is, the government is in the hands of presbyters or elders who compose the ecclesiastical bodies of various grades. 1. The *Consistory* is the governing body in the local church. It is composed of the pastor (if there be one) and elders and deacons chosen or approved by the communicants. Of this body the pastor is president *ex officio*, and he has all the rights of a ruling elder. A church may appoint as many elders and deacons as it may think expedient, and it is not necessary that they should be equal in number. The elders with the pastor have sole charge of all the spiritual interests of the congregation, and are the spiritual court answering to the session in the Presbyterian Church. In the admission, dismission, and discipline of members, and in choosing delegates from their own number to the classis or next higher court, the elders only have a voice. To them belongs the oversight of the flock; they are to assist the pastor in family visitations, and they are especially charged to guard the flock against ministers who teach false doctrines or lead immoral lives. It belongs to the

deacons to care for the poor, and especially for the poor members of the flock. They are to collect and distribute the alms, and visit and comfort the needy and the suffering. While these two offices are thus distinct, yet the elders and deacons are joined together in one board and as such "have an equal voice in whatever relates to the temporalities of the church, to the calling or dismission of a minister, or the choice of their own successors." Usually this body is the incorporated board of trustees for the holding and management of all the property of the church. Elders and deacons are elected for a term of two years, and half of the places become vacant annually. A person may be re-elected immediately and repeatedly. This system of a limited term of office was adopted originally by all the Reformed churches of the Presbyterian order in Europe. It is claimed that it has great and manifest advantages, and many Presbyterian churches in America and in increasing numbers have adopted it. There are three modes of electing elders and deacons. *a.* The consistory chooses and gives opportunity to the members to object. *b.* The consistory nominates a double number and the communicants elect. *c.* The communicants both nominate and elect. Elders and deacons who are out of active service form an advising body called the Great Consistory, who may be consulted when a minister is to be called, or when other matters of peculiar importance occur relating to the peace and welfare of the whole congregation.

2. The *Classis* is the next higher body and corresponds to the Presbytery of the Presbyterian Church. It is composed of the pastors of the churches in a certain district, an elder delegated by each church, and such ministers without charge as have been received by the classis. The classis examines candidates for the ministry, approves calls, ordains, dismisses, and deposes ministers, forms new congregations, and is a court of appeal from sentences of the consistory. The classis meets twice a year, and sends a report on the state of religion to the Particular Synod. It has a system of oversight of the churches, and annually makes inquiry whether ministers and churches observe certain constitutional requirements.

3. The *Particular Synod* is composed of a certain number of ministers and elders delegated by the classes. It has power to form new classes and to transfer a congregation from one classis to another. It is a court of appeal from decisions of the classes. It meets annually and reports to the General Synod.

4. The *General Synod* is the highest judicatory and represents the whole church, meets annually, and is composed of an equal number of ministers and elders delegated to it. It is the final court of appeal from decisions of the lower assemblies; it has supreme control of the theological schools; it maintains correspondence with the highest judicatories of other denominations, and it exercises a general superintendence over the spiritual interests and concerns of the whole church. The powers of all these bodies are fully and carefully defined by the constitution of the church.

CULTUS.—All the branches of the Reformed Church in Europe possessed liturgies and used them. The Reformed Church of the Netherlands has her liturgy and used it, allowing, at the same time, considerable liberty to the officiating minister. The church in America, of course, possessed and used their liturgy, which has in the course of time been somewhat modified, particularly by the introduction of some new optional forms. The forms of prayer for ordinary public worship are not used by the ministers except as models for their guidance in composing their own prayers, which work every one is expected to do to the best of his ability. The constitution, besides establishing an order of worship, requires some forms to be used, and their use, therefore, is universal, viz.: 1. For the baptism of infants. 2. For the baptism of adults. 3. For the administration of the Lord's Supper. 4. For

the ordination of ministers. 5. For the ordination of elders and deacons. 6. For the excommunication of an offender. 7. For readmission of the penitent. The liturgy is the growth of time, and has been drawn from various sources. Calvin's liturgy was its basis. A liturgy based on this was used by the Church of the Foreigners worshipping in London under the superintendence of A. Iasco in the Church of Austin Friars in the time of Edward VI. In 1566 various forms for the use of the churches of the Netherlands were collected and published by Rev. Petrus Dathenus. The liturgy was modified as occasion demanded until fixed by the Synod of Dort and brought to this country by the colonists. Of late years there has been an increasing tendency to introduce more of the formal liturgical element into public worship. In addition to the reading of the ten commandments in many churches the psalter is read responsively, and the Lord's prayer and apostolic creed are repeated. There is no desire for what is called ritualism, but a disposition to give to the people a more active, expressed participation in the worship of the congregation.

MISSIONARY AND OTHER AGENCIES.—1. *Board of Domestic Missions.*—Considerable missionary work was done in the home field from the beginning. But it was without a general organization or definite system, was confined to pastorless churches using the Dutch language, and was performed by pastors making missionary tours among these churches. In 1831 the Board of Domestic Missions was formed, and a great impulse was given to the work, resulting in the establishment of churches in Western New York and in the Western States, and in new and growing communities in the East. In the year 1887-8 the board received \$28,737.52 from the churches, Sunday-schools, and Woman's Executive Committee, and 90 pastors and 108 churches were aided.

2. *The Church Building Fund.*—From this fund moneys are loaned to feeble churches to aid them in erecting houses of worship. During the year 1887-8 the moneys received for this fund amounted to \$17,061.25, including \$6,936.46 received from the Woman's Executive Committee.

3. *The Board of Foreign Missions.*—The first ministers labored considerably for the conversion of the Indians and with some success. From the early part of the present century the Reformed churches co-operated with other denominations in sending the gospel to the heathen in foreign lands. For a number of years the church was associated in this work with the American Board of Commissioners for Foreign Missions. Since the year 1857 it has carried on the work independently, and has sustained three flourishing missions, one at Amoy, in China, a second in the Madras Presidency, India, and a third in the empire of Japan. The entire number of ordained missionaries connected with all the stations is 25; of unordained, 3; of married women, 21; of unmarried, 9; making a total of 58. Besides these there are many native helpers. The missionaries have done their full share in translating the Scriptures and providing a Christian literature for the people. The total expenditure of the board for the year 1887-8 amounted to \$98,495.61; of this sum \$19,329.04 were received through the Woman's Board of Foreign Missions.

4. *Board of Education.*—Indigent young men are assisted in their preparation for the ministry by contributions from the churches and income from invested funds, chiefly in the form of scholarships. Also moneys are, to some extent, appropriated for the support of educational institutions. During the year 1887-8 eighty students received assistance, and the payments of the board for all purposes amounted to \$22,013.99.

5. *Board of Publication.*—It is the aim through this agency to supply the church with good Christian literature, and especially literature of denouina-

tional interest and value. It has its benevolent as well as business department. It has made donations during the last year amounting to \$1380.85.

6. *Widows' Fund and Disabled Ministers' Fund.*—These provide for families of deceased ministers and for disabled ministers. An interest in the former is secured by certain annual payments, but the latter is a pure charity. The capital sum of the former is \$73,970.99; of the latter \$53,817.28. The available income of both these funds is largely increased by contributions from the churches.

To these agencies we add that of the press. A monthly magazine called the *Mission Field* is published, and the *Christian Intelligencer* is the second oldest religious weekly in New York. It may be regarded as the organ of the denomination, being specially devoted to its interests. The minutes of the General Synod of June, 1888, furnish the following statistics: Churches, 546; ministers, 555; families, 47,520; communicants, 87,015; Sunday-schools, 750; scholars, 96,019; contributions for religious and benevolent purposes, \$284,902; for congregational purposes, \$970,856. The churches were at first known as Low Dutch Reformed churches or simply as Dutch churches. The title of the denomination afterwards was the Reformed Protestant Dutch Church. In 1867 it was changed to the "Reformed Church in America."

For further information the reader is referred to Ypey and Dermout's *Gechiedenis de Hervorm de Kerk, Hansen's Reformed Church in the Netherlands, Corwin's Manual of the Reformed Church in America* (3d edition), *Centennial Discourses* (1876), *Centennial of the Theological Seminary at New Brunswick* (1884), Gann's *Life of Livingston, Demarest's History and Characteristics of the Reformed Dutch Church, and Acts and Proceedings of the General Synod.*

(D. D. D.)

REFORMED CHURCH IN THE UNITED STATES. This religious body, formerly known as the German Reformed Church, is directly derived from the Reformed churches of Germany and Switzerland. It may, therefore, claim to be, in a special sense, the American representative of the German branch of the great religious movement of which, in the sixteenth century, Zwingli, Calvin, and Ursinus were the most eminent leaders. Its standard of doctrine is the Heidelberg Catechism, and in government it holds to the Presbyterian system.

The history of the German Reformed Church in America properly begins with the dreadful period in German history which is known as the War of the Palatinate (1689-1697). The region of the Rhine had been utterly devastated, and cities like Heidelberg, Spire, and Worms were in ruins. Driven from their desolated homes by successive French invasions, many thousands of the peasants of the Palatinate sought a home in foreign lands. Large numbers were conveyed to America, through the charity of Queen Anne of England, and small German settlements were founded in Pennsylvania before the end of the seventeenth century. Poverty and oppression continued in the fatherland after peace had been nominally declared, and emigration increased with each succeeding year. The extremely cold winter of 1709, which, it is said, for a time rendered Switzerland almost uninhabitable, started another wave of emigration, which was largely composed of Swiss elements. About the middle of the last century it was estimated that one-half of the German population of Pennsylvania belonged to the Reformed Church. Among them were many descendants of the Huguenots who fled from France at the revocation of the Edict of Nantes. Beginning with 1709 we divide the history of the Reformed Church in the United States into five periods:

I. 1709-1746.—During this period the records of the church are very incomplete. The people were very poor, and religious meetings were often held in private houses. Congregations were frequently served

by unordained ministers. In 1709 John Frederick Hager was commissioned by the Society for the Propagation of the Gospel to labor "among the Palatines, New York." Cotemporary with him were John Jacob Oeili, in New York, and Henry Hoeger, in Virginia. Samuel Guldin preached in Pennsylvania before 1718, as appears from a volume published by him in that year. John Philip Boehm, who had been a schoolmaster in the Palatinate, began to preach, without ecclesiastical authority, to the congregations at Falconer Swamp, Skippack, and When Marsh, Montgomery co., Pa., as early as 1720. He was regularly ordained in 1729 by the Dutch ministers in New York, by special permission of the Classis of Amsterdam. John Henry Goetschius, a native of Zurich, was in 1730 pastor of eleven congregations, of which New Goshenhoppen was the most prominent. In 1727 the Rev. George Michael Weiss, at the request of the Classis of the Palatinate, accompanied a company of 400 Palatine emigrants to America, "in order that they might not be without religious instruction." In 1730 he revisited Europe, in company with Elder Jacob Reiff, for the purpose of collecting money and good books for the Reformed churches of Philadelphia and Skippack. This mission led to important results. A considerable sum of money was collected, and the synods of Holland became so profoundly interested in the American churches that they agreed to take them under their special care and supervision, and to supply them with ministers.

In 1730 John Peter Miller and J. B. Rieger came to America, under the auspices of the Consistory of Heidelberg. Miller afterwards left the Reformed Church, and became the prior of the convent of Seventh-day Baptists which had been founded at Ephrata, Pa., by Conrad Beissel. In 1742 Henry Antes and others joined with Count Zinzendorf in the organization of the "Congregation of God in the Spirit." They proposed that the various churches should be united in a higher unity, without sacrificing their denominational peculiarities. Though the fact was rather implied than expressed, the Moravians were to be the controlling power in the whole movement. The "Congregation" ordained a number of ministers for service in the Reformed churches. These declared themselves opposed to the proposed union with Holland, and professed their adhesion to the decrees of the Synod of Berne. On the failure of this union movement, about 1746, most of these ministers joined the Moravians.

II. 1746-1793.—The arrival in America of Michael Schlatter, on the 1st of August, 1746, was an important event in the history of the Reformed Church. He had been sent by the synods of Holland with directions to visit the scattered churches, to establish pastoral charges, and if possible to organize a *Cœtus*, or ministerial conference. In this work he was eminently successful. The *Cœtus* met for the first time in Philadelphia in 1746, and was fully organized in 1747. It differed from a synod only in the fact that its decisions were not final until they had been approved by the synods of Holland. At the request of the *Cœtus*, Schlatter, in 1751, went to Europe for the purpose of presenting the cause of the destitute German churches in America. His mission was very successful, especially in Holland. A sum of money, amounting to £12,000, was collected and invested for the benefit of the American churches. In 1752 he returned to America, bringing with him six young ministers.

The success of Schlatter's mission suggested an extensive educational movement in behalf of the Germans of Pennsylvania. A large fund was brought together in England, and a number of schools were founded which were known as "charity schools." Schlatter was induced to become Superintendent of Schools, but unfortunately this educational movement was made to assume a political character, and proved a failure. Schlatter became disheartened, and with-

drew from active participation in ecclesiastical affairs. After his retirement the most prominent men in the *Cœtus* were J. Conrad Steiner, author of several volumes of sermons, and William Stoy, who was also an eminent physician. Dr. J. Daniel Gross was professor in Columbia College, New York, and author of a work on *Moral Philosophy*. Philip William Otterbein was a warm friend of the early Methodists, and though himself remaining in the Reformed Church, organized religious societies, from which sprang the denomination known as the "United Brethren in Christ." Rev. Drs. Caspar Weyberg and William Hendl were successively pastors in Philadelphia, and in connection with Drs. J. H. C. Helmuth and H. E. Muhlenberg, of the Lutheran Church, were especially prominent in the organization of Franklin College, an institution founded in 1787 at Lancaster, Pa., to promote higher education among the Germans. This college was named in honor of Benjamin Franklin, who was at that time governor of Pennsylvania, and who contributed liberally to its endowment. Unfortunately its resources were not equal to its necessities, and for many years it failed to meet the expectations of its founders.

In 1770 the Dutch churches of New York invited the German churches of Pennsylvania to unite with them in the establishment of a single General Synod, but the Germans declined, on the ground that they were unwilling to be separated from the synods of Holland. During all these years the minutes of the *Cœtus* were sent to Europe for revision and approval. If the synods of Holland had granted to the *Cœtus* the privilege of conferring the rite of ordination this intimate relation might have been indefinitely continued, but on this point the Hollanders were inflexible. The assertion of the right to ordain ministers led to the final separation, which was, however, accomplished without extended controversy. The *Cœtus* declined, in courteous terms, to submit its future proceedings to the revision of "the fathers," and thus by its own act became an independent synod.

III. 1793-1820.—The Synod of the German Reformed Church met for the first time at Lancaster, Pa., in 1793. The number of ministers at this time was about twenty. The condition of the church was not encouraging. Its earliest pastors, who had been trained in Europe, had passed away, and many of their successors had been imperfectly educated. In consequence of the delay in establishing literary institutions there was a great scarcity of ministers, and many churches were lost to the denomination. The introduction of the English language into the services of the church led to serious conflicts. The earliest Sunday-school was organized in the church on Race street, near Fourth, Philadelphia, April 14, 1806. A few books were written, by Drs. C. L. Becker, Samuel Helfenstein, and others, but there was little literary activity. The pastors, however, generally attended faithfully to the duties of their office, as they understood them, and were especially careful to catechize the young as a preparation for their admission to full membership in the church. The most hopeful indication was a general longing for better things, which, although expressed in abortive synodical resolutions, was a prophecy of future advancement.

IV. 1820-1863.—At the beginning of this period the number of ministers was about seventy. The difficulty of bringing them together to synodical meetings probably first suggested the desirability of establishing subordinate ecclesiastical bodies. The Classis, or Presbytery, has always been regarded as of fundamental importance to the reformed system of government, and its introduction into the German Reformed Church of this country appropriately marks the time of its awakening to the nature of its mission.

In 1820 the classes, eight in number, met for the first time. In the same year the synod, convened in Hagerstown, Md., adopted a plan for the establish-

ment of a theological seminary, and Dr. Philip Milledoler, of New York, was elected professor of theology. Dr. Milledoler declined the call, and it was not until 1825 that the seminary was formally opened at Carlisle, Pa. The first professor of theology was Dr. Lewis Mayer. In the summer of 1825 Rev. James R. Reily visited Europe, and collected a considerable sum for the new institution. One of the most liberal contributors was Frederick William III., king of Prussia. In 1829 the seminary was removed to York, and in 1837 to Mercersburg, Pa.

Marshall College was founded at Mercersburg in 1835. The first president was Rev. Frederick A. Rauch, Ph. D. (1806-1841), who is best known as the author of a work on *Psychology*, which may be said to have introduced this science to the attention of American students. John Williamson Nevin, D. D., LL. D. (1803-1886), was professor of theology at Mercersburg, 1840-51, and president of Marshall College, 1841-53. He was a man of great learning and ability, and to the end of his life his influence was extraordinary. (See NEVIN.) In 1843 a commission was sent to Germany to invite a German professor to accept a professorship at Mercersburg. Their choice fell upon the Rev. Dr. Philip Schaff, at that time professor extraordinary at Berlin. He accepted the call, and was installed professor of church history and biblical literature in 1844. The succeeding years were marked by intense theological and literary activity. The two professors, Drs. Nevin and Schaff, labored in perfect harmony, and their influence extended far beyond the limits of the Reformed Church. In 1846 Dr. Nevin published his *Mystical Presence*, a book which has been regarded as marking an epoch in the history of American theology. Soon afterwards he published *The History and Genius of the Heidelberg Catechism*, and a tract, entitled *Antichrist, or the Spirit of Sect and Schism*. After 1849 he edited the *Mercersburg Review*. During the same period Dr. Schaff wrote his *History of the Apostolic Church* and several other books. He also edited the *Kirchenfreund*, a monthly magazine, devoted to the interests of the German churches. (See SCHAFF.)

German theology and philosophy were in those days little known in this country, and their introduction at Mercersburg induced controversy and opposition. Gradually the utterances of the professors came to be known as "Mercersburg theology"—a term at first employed by its opponents, but afterwards tacitly accepted by its friends. It did not properly designate an organized theological system but a movement in the life of the church; and consequently left room for injudicious and extreme utterances on the part of professed friends which did it more harm than the attacks of its most violent opponents.

In 1853 Marshall College was removed to Lancaster and united with Franklin College, the Reformed Church having first purchased the Lutheran interest in the latter institution. The theological seminary remained at Mercersburg until 1871, when it was also removed to Lancaster. Since the retirement of Drs. Nevin and Schaff, theological professorships at Mercersburg and Lancaster have, at various times, been occupied by the Rev. Drs. Bernard C. Wolff, Henry Harbaugh, E. V. Gerhart, Thos. G. Apple, and Frederick A. Gast.

The history of the Reformed Church in the West begins with the first decade of the present century. Rev. Jacob Christman began to preach in Ohio in 1803. In the same year Rev. Samuel Weyberg is said to have preached the first Protestant sermon west of the Mississippi River, at Cape Girardeau, Missouri. In 1804 Rev. John Jacob Larose began his labors in Ohio. The Synod of Ohio was organized in 1824 by eight ministers, and was for many years independent of the Synod of the United States. The Western Theological Seminary and Heidelberg College were founded at Tiffin, Ohio, in 1850. Theological professorships have been held by the Rev. Drs. E. V. Ger-

hart, Moses Kieffer, J. H. Good, Herman Rust, and D. Van Horne.

About the year 1853 the work of missions among the Germans in the West was greatly enlarged. In this movement the Rev. Drs. Max Stern, H. A. Muehlmeier and H. J. Ruetenik were especially prominent. Among its results may be mentioned the formation of three German synods, with forty thousand members and all the institutions necessary to effective church-work.

V. 1863-1889.—In 1863 the General Synod met for the first time, having been founded by the concurrent action of the two existing synods. The same year is memorable for the Tercentenary Celebration of the Heidelberg Catechism, which greatly stimulated the devotion and benevolence of the church. From 1866 to 1878 there was a serious controversy concerning liturgical worship, but in the latter year all the questions at issue were committed to a special commission which was successful in restoring peace to the churches. The word "German" was erased from the church-title in 1869. The question of organic union with the Reformed Church in America has recently claimed renewed attention. The chief obstacle in the way of union is a difference in doctrinal standards. Though both churches are equally attached to the Heidelberg Catechism, the Reformed Church in America holds, in addition, the Belgic Confession and the articles of the Synod of Dordrecht. The German body has hitherto declined to subscribe formally to the latter confessions, regarding them as the exclusive possession of the Church of Holland.

The Reformed Church in the United States, as at present constituted, is governed by a General Synod, which meets triennially. There are eight district synods, of which five are English and three German. The number of classes is 54. There were, in 1887, 817 ministers, 1481 congregations, and 183,980 communicant members. The principal literary institutions connected with the church are Franklin and Marshall College, Lancaster, Pa.; Heidelberg College, Tiffin, Ohio; Ursinus College, Collegeville, Pa.; Catawba College, Newton, N. C.; Calvin College, Cleveland, Ohio, and the German Mission House at Franklin, Wis. Four orphan homes are under the care of the church, and twenty-three periodicals are published in its interest. The missionary activity of the Reformed Church has been mostly directed to the spiritual care of the German and Swiss immigrants who have formed settlements in the West, but the means at hand have proved utterly inadequate to this enormous work. A foreign mission, founded in Japan in 1878, has proved successful. The Germans have also established a mission among the Winnebago Indians.

The Reformed Church has few distinctive peculiarities. It aims to hold the truth in due and harmonious proportion. Its Catechism, according to its own statement, rests upon the Apostles' creed. It teaches substantially the Augustinian doctrine of natural depravity and salvation by free grace alone; but allows freedom for more moderate views on the subject of predestination than are usual in the more strictly Calvinistic Reformed churches. With regard to the sacrament of the Lord's supper it teaches the spiritual real presence of the flesh and blood of Christ in the Holy Eucharist, for believers only. It regards the children of Christian parents as proper subjects for baptism. The church insists that ministers shall carefully instruct the young in the teachings of the Catechism, as the best means of preparing them for the public profession of their faith. Confirmation is practised, not as a sacrament but as a solemn and appropriate rite. In worship the church is moderately liturgical, valuing and using a liturgy without abridging the liberty which is the privilege of pastors and people. In brief, the church, like its honored symbol, allows all proper liberty in the development of the truth; and withal is full of charity towards other branches of the Church of Christ.

Authorities.—*History of the Reformed Church*, vol. 1, by Lewis Mayer, D. D.; *Harbaugh's Life of Schlatter*; *Fathers of the Reformed Church* (5 vols.), by Harbaugh and Heisler; *Historic Manual of the Reformed Church in the United States*, by Joseph Henry Dubbs, D. D. (J. H. D.)

REFORMED EPISCOPAL CHURCH. This church was organized in the city of New York, Dec. 2, 1873. The history of this movement dates back to the English Reformation. The antagonism of Henry VIII. was with the papal supremacy. With the Reformation he had no sympathy. Toward it his opposition was open and intense. The real work of church reform in England dated from the reign of Edward VI. Then for the first time the errors of the Church of Rome were assailed, and the recasting of the doctrine, discipline, and worship of the English church into a Protestant mould began. The work was, however, arrested before completion by the early death of Edward. His Prayer Book, set aside by his successor, was restored by Elizabeth. Changes were made, but not in the line of Cranmer's revision. Their avowed object was the conciliation of the Romish party. From that time on there have been changes and additions in the English Prayer Book in this same direction. The result has been a divided church—two parties, the one sympathizing with Romish views and the other maintaining evangelical doctrines. The daughter church in the United States, the Protestant Episcopal, inherited the liturgy and traditions of the mother church, and also its diversities of thought. After the Revolution, the Episcopal Church in this country needed to be reorganized, and Bishop White sought to place it on an evangelical basis. To this end he revised the Prayer Book; other influences, however, gained ascendancy, and his "Proposed Book" was rejected. Consequently the same conflicts have continued to disturb the daughter that had so long agitated the mother church. In 1835 a new infusion of life began in high church circles. The so-called *Tracts for the Times*, emanating from Oxford, were immensely popular. The writings of the Fathers and mediæval literature were brought into prominence. The sacramentarian and sacerdotal theories, and the divine right of Episcopacy, became the standard of a new movement. The daughter church in America felt the impulse. The high church element fell into line, and, cautiously at first, began to teach and preach the advanced doctrines. The evangelical element took the alarm and rallied at once. It was by far the dominant party. Its leaders were among the foremost men in the church. No less than three organizations were put in operation to resist the inroads of these new tendencies. But steadily the innovations made headway. Those who advocated them claimed that the Prayer Book was with them. The Evangelicals had initiated the fight, confident in right and in numerical strength. It was not long, however, before they were on the defensive. Their numbers decreased, while their opponents grew stronger and more aggressive. At last the Evangelicals found themselves reduced to that extremity that they could no longer fight, and were necessitated to become petitioners. They asked for such changes in the Book of Common Prayer as would enable them with a good conscience to remain in the church. Their appeals were unnoticed. On all occasions they were made to understand that if they could not conform to high church legislation and Prayer-Book interpretation, they had better leave.

It was about this time that the Right Reverend George David Cummins, D. D., Assistant Bishop of Kentucky, began to show an interest in the ecclesiastical questions of the day. He had been consecrated bishop in 1866. Up to this event and for several years after he was seemingly indifferent to the struggle that was going on. His views had ever been evangelical, but his conservative tastes had been drawing

him seemingly closer to the high church men. It was in the discharge of the duties of his new office that his eyes were opened. There were practices in vogue in his diocese that he could not approve. As assistant bishop he was powerless to command or even rebuke. Remonstrance was all that was left him, and this was met by appeals to the Prayer Book, which, it was asserted, authorized what he condemned. This claim drove him to a study of the questions that were agitating the church, and he was not long in making up his mind and taking his stand. He then became bold and aggressive. In one respect he stood alone among the evangelical bishops and leaders of the party. Experience had taught him that the root of the trouble was in the Prayer Book. Its language in some instances taught, and in others shielded, the priestly and sacramentarian theories, and as long as it remained as it was he saw clearly that the Romanizers would have the right of way in the church. He therefore called for a revision of the Prayer Book, and a perfecting of the work that Cranmer had so well begun, and that Bishop White had in vain attempted to carry out.

In October, 1873, the Evangelical Alliance assembled in the city of New York. Bishop Cummins was an interested and active worker. On October 12 the members of the Alliance united in a communion service. Bishop Cummins was present, making an address and delivering the cup. From within his church, rebuke, censure, threats of ecclesiastical discipline, were unsparingly showered upon him. Not only had he united with non-episcopally ordained ministers in celebrating the Lord's Supper, but as a bishop in the church he had compromised his office by taking a subordinate place. So intense was the hostility aroused by this unchurchly act on his part, and so bitter was the manifestation both in public attacks and in private communications, that he felt that his usefulness in his church, and especially in his diocese, was at an end. Prior to this the painful conclusion had forced itself upon him that Prayer Book revision was hopeless within the church; and without such revision he felt assured that the evangelical element must die out. Constrained by these considerations he determined to withdraw from the church. His resignation, addressed to the presiding bishop, is dated October 30. On consultation with friends an organization was determined upon, and a call issued. The object was thus stated: "To organize an Episcopal Church on the basis of the Prayer Book of 1785 (the Bishop White Prayer Book), a basis broad enough to embrace all who hold the faith once delivered to the saints, as that faith is maintained by the Reformed churches of Christendom; with no exclusive and unchurching dogmas toward Christian brethren who differ from them in their views of polity and church order."

Eight clergymen and nineteen laymen responded to this call, and the Reformed Episcopal Church was organized. It claims to be the church of the Reformation—the church that Edward VI. and Archbishop Cranmer and Bishop White would have had, if the times had permitted, and to the Anglican and American Episcopal Church it stands in the same relation as these churches do to the churches of Rome and of the East—a *Reformed Church*.

Doctrine.—This church plants itself upon "the Holy Scriptures of the Old and New Testaments as the Word of God, and the sole rule of faith and practice." It "declares its belief . . . in the creed, commonly called the Apostles' Creed; in the divine institution of the sacraments of baptism and the Lord's supper; and in the doctrines of grace substantially as they are set forth in the Thirty-nine Articles of religion." It is emphatic in its protest against those errors that necessitated its organization.

Worship.—It is liturgical, but not exclusively so. It retains the use of "a liturgy which shall not be im-

perative or repressive of freedom in prayer." In its constitution it provides that the "Book of Common Prayer . . . shall be used in this church, at such times and with such liberty as the canon on this subject shall provide; but no canon shall make its use imperative on all occasions, nor forbid the use of extempore or other prayer at suitable times." Rejecting the Prayer Book of the Protestant Episcopal Church, that of 1785, known as the Bishop White Prayer Book, was adopted, and has been so amended as to suit present needs.

Ministry.—In its ministry it "adheres to Episcopacy, not as of divine right, but as a very ancient and desirable form of church polity." It holds to two orders—presbyters and deacons. The bishopric is an office, and the bishop is "*primus inter pares*."

Government.—Its government rests in, 1. A *General Council* that at present includes all its bishops and presbyters, with lay representatives who shall be communicants and members of the congregation they respectively represent. This body represents and legislates for the churches in the United States and Canada. Its meetings are now biennial. 2. *Synodical Councils.* The whole body is divided into synods. Each synod is under the jurisdiction of a bishop with his standing committee. It has its annual council, and legislates on matters that are purely local. 3. *Parish* organization, which consists primarily of the congregation. From them, by election, come vestrymen, wardens, parish council, members of the general and synodical councils, and, through the vestry, the pastor.

Church Union.—Bishop Cummins, in his address at the organization of the church, said: "We regard our movement only as a step towards the closer union of all evangelical Christendom. For this we shall labor and pray. We gladly acknowledge the validity of the ministerial orders of our brethren whom God has sent into his vineyard, and whose labors he has accepted and blessed. We shall invite all ministers of evangelical churches to occupy our pulpits, and to take part in our services, and we shall rejoice to meet them and their flocks as often as may be expedient around the Lord's table, and acknowledge that we, being many, are one body in Christ, and members one of another."

The aim of the church has been in this direction. It has broken down the barrier of Episcopacy "as of divine right," and has placed it on the historic basis, "as a very ancient and desirable form of church polity." In adopting the XXXIX Articles of the Church of England, it has so amended the XXIVth that it reads: "The doctrine of 'apostolic succession,' by which it is taught that the ministry of the Christian Church must be derived through a series of uninterrupted ordinations whether by tactual succession or otherwise, and that without the same there can be no valid ministry, no Christian church, and no due administration of baptism and the Lord's supper, is wholly rejected, as unscriptural and productive of great mischief. This church values its historic ministry, but recognizes and honors as equally valid the ministry of other churches, even as God the Holy Ghost has accompanied their work with demonstration and power." In its canons it provides that—"Any presbyter of another church may be received by a bishop and standing committee as a presbyter of this church, without reordination." It reciprocates "fraternal greetings" with other evangelical churches. It invites to friendly interchange of pulpits. It receives communicants by letter from other churches, and on every communion occasion it invites "fellow-Christians of other branches of Christ's church" to the Lord's table.

Statistics.—The following report was made to the General Council, May, 1887: Bishops, 7; ministers, 92; communicants, 8467; Sunday-school scholars, 11,811; teachers, 699; contributions, \$156,064. Property

unincumbered, \$1,083,361. These statistics include the churches in the United States and Canada. There is a branch of this church in England, but without organic connection with the General Council. Its theological school has graduated its first class of two students. Its faculty consists of a dean and three professors. It begins its second year with eight students. The *Episcopal Recorder*, published in Philadelphia, is the organ of the church. (B. B. L.)

REFORMED PRESBYTERIAN CHURCH IN NORTH AMERICA. This is the formal title of the body which is commonly termed the *Covenanter Church*. The former name by its first part carries us back to the second reformation of British history, in the seventeenth century. By its second part it indicates the form of government, Presbyterian. The familiar name, *Covenanter*, belongs to the history of the Church of Scotland in the seventeenth century. The restoration of Charles the Second in 1660 marked the beginning of sore persecution, the "killing times" for those who held to the Covenants of Scotland, and became known as *Covenanters* (see *COVENANTERS*, in the *ENCYCLOPEDIA BRITANNICA*). It is from this people the *Covenanter Church* in America originated, and correspondence is maintained by it with the Synod of the Reformed Presbyterian Church in Scotland.

I. Early History.—The persecuting times in Scotland were marked not only by the martyrdom of many of the Covenanters, but also by the voluntary and enforced exile of many more. They were banished to North America and Jamaica, many sought an asylum in the New World, many found refuge in Ulster, whence their children came to these shores. In 1684 thirty were banished to Carolina; four, the same year, to New Jersey; one hundred, twenty-four of them women, were transported to New Jersey. The first emigrants came mostly to Delaware, Eastern Pennsylvania, New York, and South Carolina. In the early part of the eighteenth century they were found in the Cumberland Valley, forming "societies" as in Scotland—that is, worshipping assemblies without a pastor, along the tributaries of the Susquehanna. The principal settlements were at Octorara and Paxtang, and on the Conococheague in Pennsylvania. These kept up correspondence, and in 1743 organized a "General Meeting" to legislate for the *Covenanter* communities. The same year they covenanted at Octorara, renewing the Scottish Covenants, and vowing to "keep their bodies, property, and conscience against all attacks; to defend Christ's gospel and the purity of the church; to submit to no ruler who would not submit to Christ, and to defend their liberty from fears without and within." The first preaching they received was from Rev. Alexander Craighead (1707-66) in 1743. He was ordained a Presbyterian, but acceded to the Covenanters, and remained with them seven years, and soon after leaving them migrated to North Carolina. The first *Covenanter* settlement in the State of New York was on the Walkill, in Orange co., N. Y. In the year 1748 Mr. James Rainey removed from Philadelphia and settled here, and in 1753 a society was formed. The banishment of Covenanters to Carolina has already been noted. Chester District, in South Carolina, early became their centre, and after Mr. Craighead had gone South some removed from Pennsylvania, settling along Rocky Creek, and were soon strengthened by emigration from Ireland. By the middle of the eighteenth century there were societies of Covenanters from Connecticut to South Carolina. The Pennsylvania societies earnestly desired help from the mother church in Scotland, when left by Mr. Craighead in 1749. The first minister to come was Rev. John Cuthbertson (1718-91), who landed at Newcastle, Del., Aug. 5, 1751. He served the scattered societies for 22 years, making his home in Octorara. His diary is extant, and we have a full account of his extended journeys taken on horseback, in visit-

ing the Covenanters in New York, Vermont, New Hampshire, Connecticut, New Jersey, Maryland, Virginia, and Pennsylvania, as far as the Ohio River. He chronicles the names of the families he visited. In 1759 Rev. Alexander McDowell left the Presbyterian Church and joined the Covenanters, being in sympathy with them in their adherence to the Solemn League and Covenant and the usages of the Church of Scotland. He ministered mainly to the New England societies, but was also in Eastern Pennsylvania, whence returning to New England in 1761 his further history is not known. In 1766 the Reformed Presbytery of Ireland sent out Rev. Daniel McClelland. He had been in America, but went back and pursued his theological studies, being ordained in 1765. He preached for a time among the societies in Connecticut and Eastern Pennsylvania, going in the spring of 1768 to New England and was lost sight of. In 1772 Rev. William Martin (1729-1806) came from Ireland with a colony, which settled in South Carolina on Rocky Creek. He graduated at Glasgow in 1753, and was ordained at Vow on the lower Baun, the first Covenanter minister ordained in Ireland. In the spring of 1773 the Paxtang society sent a commissioner to Ireland to secure ministerial help for Mr. Cuthbertson. Rev. Alexander Dobbin and Rev. Matthew Linn answered the call and were met at Philadelphia Dec. 13, 1773, by Mr. Cuthbertson. These three ministers constituted the first Reformed Presbytery in America, March 10, 1774. Each had his field of labor in Eastern Pennsylvania, Mr. Martin, the fourth Covenanter minister then in America, laboring in South Carolina.

This brings us to the eve of the Revolution. The trials of the fathers in Scotland had led them to narrowly examine the principles of civil government, and *Lex Rex* by Samuel Rutherford, the *Hind Let Loose* by Alexander Shields, and *Jus Populi Vindicatum* show their conclusions. Their children were filled with democratic ideas and were not only in sympathy with the rising spirit of the colonies but were in the van. The covenanting of 1743 at Octorara had challenged the attention of the provincial governor. Mr. Craighead spread their principles in Carolina, and the members of the convention at Charlotte that formed the first declaration of independence, May, 1775, known as the Mecklenburg Declaration, were members of the churches he had founded. Thomas Jefferson had before him the account of the proceedings at Octorara when he penned the Declaration of 1776, and the Mecklenburg Declaration is also reflected in it. July 2, 1777, Rev. John Cuthbertson and many of his people, after sermon, swore fidelity to the cause of the colonies. Rev. William Martin was imprisoned and brought before Lord Cornwallis in 1780 at Winnsboro, South Carolina, for his patriotism.

The Covenanters went heartily into the war to throw off the yoke of Great Britain. War is leavening. The changed condition of affairs led to discussion and then to assimilation with the body nearest them, the Associate, made up of members of the body which rose in Scotland by secession from the Established Church in 1732. The union was formed at Philadelphia, Nov. 1, 1782, and the united church was known as the Associate Reformed (*q. v.*). The larger part of the Covenanters of the North followed their ministers into the union. The Southern Covenanters were not involved in this step. The remnant in the North, being without a minister, fell back again to their condition in 1749.

In 1789 the Reformed Presbytery of Scotland sent out Rev. James Reid on a missionary tour, in answer to repeated requests from America. He journeyed from New York to South Carolina, reorganizing and encouraging the people, spending less than a year. His report produced fruit, and Rev. James McGarragh (1752-1816) was sent by the Reformed Presbytery of Ireland, reaching South Caro-

lina in the spring of 1791. Rev. William King (1747-98) was sent by the Reformed Presbytery of Scotland and reached South Carolina in the fall of 1792. They were associated as a committee of the Scotch Presbytery. They restored Rev. William Martin, who had been disciplined for intemperance. In 1793 Rev. James McKinney (1759-1802) came from Ireland, having fallen under the ban of the British government at home, on account of his sympathy with the Irish cause. On his arrival he favored the formation of a Presbytery, but acted with the Scotch committee. He travelled from Vermont to the Carolinas, ministering to the societies and organizing many congregations. In the fall of 1797 Rev. William Gibson (1753-1838) came from Ireland, also John Black and Samuel B. Wylie, students of theology.

Rev. James McKinney and Rev. William Gibson, with ruling elders, May 18, 1798, at Philadelphia, reconstituted the Reformed Presbytery, that had been dissolved by the union of 1782. June 24, 1799, Alexander McLeod (1774-1833) was licensed by this Presbytery at Coldenham, N. Y. He was pastor in New York city, 1801-33. He was chairman of the committee to prepare the testimony, and in May, 1806, the "Declaration and Testimony of the Reformed Presbyterian Church in America" was unanimously adopted by the Presbytery. In 1807 the "Terms of Communion" were prepared. The increase of the ministry and people now called for the formation of a higher court and, May 24, 1809, the Synod of the Reformed Presbyterian Church was organized at Philadelphia. The next year a theological seminary was organized at Philadelphia, and Rev. Samuel B. Wylie (1773-1852) was chosen professor. He graduated at Glasgow, 1797, and was ordained at Ryegate, Vermont, June 25, 1800, the first Covenanter minister ordained in America. He was pastor in Philadelphia, 1801-52, and for seventeen years a professor in the University of Pennsylvania. In 1823 the constitution of the supreme judiciary was altered, and a General Synod was formed, delegates chosen by the Presbyteries. The General Synod met in New York city, Aug. 2, 1825. The Presbyteries were grouped under two subordinate Synods, Aug. 12, 1831, those east of the Allegheny Mountains forming the Eastern Subordinate Synod, and those west of the mountains the Western Subordinate Synod. The growth of the church up to this period had been steady.

The scattered Covenanters in the British maritime provinces had been visited by a committee of the Northern Presbytery in 1821, Rev. James R. and Rev. Samuel M. Willson, and organized into societies. Missionaries came out in answer to appeals. Rev. Alexander Clarke (1793-1874) came from Ireland to St. John in August, 1827, Rev. William Sommerville (1800-78) and Rev. Andrew Stevenson (1810-81), then a catechist, in 1831. All these men were sent out by the Synod of Ireland, and a Presbytery was formed, April 25, 1832, under its care.

II. *The Division of 1833.*—The year 1833 marks a division in the Covenanter Church. All were united in their testimony in 1806. The Covenanters who stood out in 1782 from the union with the Associate body were justified in their caution when the national constitution was adopted in 1787. It did not embody the principles they had sworn to maintain. The *Testimony* of 1806 says of it: "There are moral evils essential to the Constitution of the United States, which render it necessary to refuse allegiance to the whole system. In this remarkable instrument there is contained no acknowledgment of the being or authority of God, there is no acknowledgment of the Christian religion, or professed submission to the kingdom of Messiah. It gives support to the enemies of the Redeemer, and admits to its honors and emoluments Jews, Mahometans, Deists, and Atheists. It establishes that system of robbing by which men are held in slavery, despoiled of liberty and property and protection. It

violates the principles of representation by bestowing upon the domestic tyrant who holds hundreds of his fellow-creatures in bondage an influence for making laws for freemen proportioned to the number of his own slaves. This Constitution is, notwithstanding its numerous excellencies, in many instances inconsistent, oppressive, and impious." Covenanters dissented, not voting, or holding office under oath to the Constitution, or serving on juries. This position proved uncomfortable during the war of 1812. Covenanters deemed the war justifiable and enlisted. Dr. Melroe preached a series of discourses on the war, vindicating the nation, but "many of the people on the seaboard were aliens, having conscientiously abstained from taking the oath of naturalization, and the government had passed an order for all aliens to remove to a distance into the interior" (*Testimony*, ed. 1881). After the war an inclination to a more charitable view of the Constitution began to appear. *Reformation Principles*, 6th ed., 1871, says: "We have seen that the African slave-trade was abolished and legally declared to be piracy; slave laws were repealed and slavery abolished in the States where most of our people had their abode; new States were rapidly organized where slavery never existed, and was now constitutionally prohibited; thus taking away the principal reason against serving on juries in our courts of law. In several States the highest courts had declared the Christian religion to be the religion of the State, and that to reproach it was a crime against public law, thus correcting the idea of the government being infidel in its character; in the meantime the nature of the federal compact was more perfectly developed and the character of the bond of union among the States better understood." The differences between the older and newer views came to a head at a meeting of the Eastern Subordinate Synod, New York, April 25, 1832. A draft of a pastoral letter came from a committee before the Synod. This argued against charging infidelity and immorality upon the Constitution. This part of the letter was stricken out by the synod. The minority published the original draft with notes. This led to the exercise of discipline, which resulted in the division of the church at the meeting of the General Synod at Philadelphia, Aug. 7, 1833. The party holding the views enunciated in 1806 are known as the Reformed Presbyterian Church (O. S.), and their highest court is the Synod. The party holding the later views are known as the Reformed Presbyterian Church (N. S.), and their highest court is the General Synod. These bodies differ in the application of their testimony to the civil institutions of the United States.

III. *The Reformed Presbyterian Church (N. S.).*—In 1835 a mission was established at Saharanpur, Northern India, and Rev. James R. Campbell and wife were sent out. In 1838 a presbytery was constituted there. In 1848 the Book of Discipline was adopted and published, and in 1850 directions for the worship of God, secret, private, and public, together with rules and forms of order, were adopted. In 1868 the General Synod was agitated by the exercise of discipline in the case of Mr. George H. Stuart, of Philadelphia, for using uninspired compositions in the praise of God, the Book of Psalms being taken by the church as the exclusive manual of praise. Previous to this the Philadelphia Presbytery had been divided into the First and Second Presbyteries. The First, to which Mr. Stuart belonged, now suspended its relations with the General Synod, while the other approved the synod's action. The former presbytery was represented as an independent body in the alliance of Reformed Churches holding the Presbyterian system, at the Philadelphia Council, 1880, but went into the Presbyterian Church in 1885. The relation of the General Synod to the work in India was interfered with during the period from 1868 to 1883, but was renewed in 1883 by the appointment of

Rev. George Scott, a native, who had been educated by the United Presbyterian Church of the United States. The centre of work is Roorkee, with out-stations. The Theological Seminary of this church is in Philadelphia.

The terms of communion number six. The second names, as the subordinate standards, the Westminster Confession of Faith, Catechisms Larger and Shorter, and Reformation Principles, the Testimony of the Church, as embodying according to the word of God the great principles of the Covenanted Presbyterian Reformation, to the maintenance of which this church is obliged by solemn covenant engagements.

The minutes of the General Synod, 1888, show 6 presbyteries, 46 congregations, and 24 ministers. The number of communicants is not given.

IV. *The Reformed Presbyterian Church (O. S.).* The arrangement of a General Synod and two subordinate synods was abolished June 26, 1840. The synod composed of all the ministers of the church and a ruling elder from each session was restored Oct. 6, 1841, and has met annually since 1861, as the supreme judicatory. The office of the deacon was long discussed in this church. Though recognized in the form of church government and the testimony of the Reformed Presbyterian Church, it had fallen into abeyance. The office was revived in 1857. In 1888 women were adjudged eligible to this office. The year 1847 witnessed the entrance on foreign mission work. Choice was made of Hayti and Rev. Joseph W. Morton was sent out. Within two years the work was abandoned, owing to his change of church relation. In 1856 Syria was chosen and Rev. Robert J. Dodds and Rev. Joseph Beattie were sent out. They labored first at Zahleh, but finally settled at Latakijeh on the coast, which is now the centre of a large work among the Nusairiyeh. This mission has charge of the work at Suadea, at the mouth of the Orontes, known as the William Holt Yates Mission, from its founder, an Englishman, his widow contributing to its support. In 1883 Rev. David Metheny, M. D., removed from the Latakijeh field, and took up new work at Tarsus, Adana, and Mersine in Cilicia, among the Arabic-speaking population. This church sustains missions to the Freedmen in Alabama and to the Chinese in California.

The Theological Seminary of this church is at Allegheny, Pa. The denominational college is at Beaver Falls in the same State, and is known as Geneva College. A course on political philosophy and Christian politics forms a special feature.

The terms of communion are six, and numbers 2, 3, 4, 6 specify, as accepted, the Westminster Confession of Faith, Catechisms Larger and Shorter, Form of Church Government and Directory for Worship of the Westminster Assembly, the Covenant of 1871, and the Testimony. The Covenant of 1871 was sworn and subscribed by the ministers and elders at the synod of that year in Pittsburg, Pa., and was afterwards taken largely throughout the church and is given in the last edition of the Testimony. The statistics of 1888 show 11 presbyteries, 121 congregations, 116 ministers, and 10,970 communicants.

Reformed Presbyterians were one in the Union cause during the civil war, and many served in the army as during the war of 1812. In 1800 it was decided that "no slaveholder should be allowed the communion of the church;" in 1823 a testimony was lifted against the oaths of Free Masonry, and this was enlarged in the Covenant of 1871 as against all secret oath-bound associations; in 1836 total abstinence was recommended, and this was embodied in the Testimony in the year 1883.

Literature.—John Howie, *Scots Worthies*; William M. Hetherington, *History of the Church of Scotland*; *Reforma-*

tion Principles, 1st ed., 1806; 6th ed., New York, 1871; *Reformed Presbyterian Testimony*, Philadelphia, 1881; *Reformed Presbyterian Advocate*, a monthly, Philadelphia; *Banner of the Covenant*, a monthly, Philadelphia; *Reformed Presbyterian and Covenant*, a monthly, Pittsburg, Pa.; *Our Banner*, a monthly, New York; Joseph M. Wilson, *Presbyterian Historical Almanac*, Philadelphia; W. B. Sprague, *Annals of the American Pulpit*, vol. ix.; W. M. Glasgow, *History of the Reformed Presbyterian Church in America*, Baltimore, 1888; Samuel B. Wylie, *Memoirs of Alexander McLeod*, New York, 1855; *Life and Work of J. R. W. Sloane*, New York, 1888. (D. B. W.)

REICHENBACH, HEINRICH GOTTLIEB LUDWIG (1793-1879), German naturalist, was born at Leipzig, Jan. 8, 1793. He studied medicine and the natural sciences in the university of his native city, and was made, in succession, doctor of philosophy and of medicine, and professor-adjunct. In 1820 he accepted a call to the chair of natural history in the medical school of Dresden, which he held till 1862. He established the botanical garden there and completely rearranged the zoölogical museum. He proposed a new system of plant-classification based on purely genetic characters, and dividing the whole vegetable kingdom into 8 classes in accordance with the development of the organs, his system being thus akin to those of Jussieu and De Candolle. His principal works are: *Conspectus Regni Vegetabilis* (Leipzig, 1828); *Flora Germanica Excursoria* with his *Handbuch des natürlichen Pflanzen-System* (Leipzig, 1837); and associated with these his *Iconographia Floræ Germanicæ* with 2700 colored engravings (vols. 1 to 22, Leipzig, 1823-84). In the department of zoölogy he published *Regnum Animale* with 79 engravings (Leipzig, 1834-36); *Deutschlands Fauna* (2 vols., 1842); and *Die Vollständigste Naturgeschichte des In und Aus-landes* (Leipzig, 1845). He died March 17, 1879. His son, HEINRICH GUSTAV REICHENBACH, born Jan. 3, 1824, also became professor of botany and director of the Botanical Garden at Hamburg. He is the author of several monographs on the Compositæ and the Orchidaceæ.

REICHENBACH, KARL VON, BARON (1788-1869), German naturalist and technologist, was born Feb. 12, 1788, at Stuttgart, Wurtemberg, where his father was court-librarian. He studied at Tübingen, where he received the degree of Ph. D. His project for the establishment of a German settlement in the South Sea Islands was suspected by the French to have some hidden political significance, and he was seized in Tübingen and committed for some months to the fortress of Hohenasperg. On regaining his freedom he devoted himself wholly to the natural sciences and their application to the industrial arts. After visiting the leading manufacturers in Germany and France, he engaged in charcoal-making at Vilingen and Hansach. In 1821, in conjunction with Count Hugo of Salm, he established iron-works and other manufactures at Blansko, Moravia, by his skilful and economical management of which he acquired a large fortune. This he invested in the purchase of large estates at Keisenberg, interesting himself largely in the rearing of silkworms and the production of beet-root sugar. In 1839 the king of Wurtemberg conferred on him the rank of baron. He is famed chiefly for his investigations into the compound products resulting from the distillation of organic substances, and as the discoverer of crocote and paraffin, and of a supposed new force in nature which he denominated Oel. He died Jan. 19, 1869. Among his literary productions may be noted: *Geologische Mittheilungen aus Mähren* (1834), the first geological monograph published in Austria; *Das Kresoot* (Halle, 1833); an edition of the works of Schweigger-Seidel (Leipzig, 1835); *Die Dynamide des Magnetsismus* (1840); *Der Sensitive Mensch* (1854); *Odismagnetische Briefe* (1855); *Odische Erwiederungen* (1856), besides many contributions to scientific periodicals.

REID, SAMUEL CHESTER (1783-1861), the designer of the present American flag, was born at Norwich,

Conn., Aug. 25, 1783. He went to sea when only eleven years old and being captured by a French privateer was detained for six months. He was afterwards a midshipman in the U. S. navy, and in the war of 1812 commanded the privateer brig General Armstrong, having 7 guns and 90 men. On Sept. 26, 1814, in Fayal Roads, he was attacked by the boats of a British squadron, but defeated them with a loss of over 200 men, while his own was only 2 killed and 7 wounded, though he was obliged to scuttle his vessel to prevent its capture. The attack on the Armstrong was long the subject of diplomatic controversy, but the case was finally decided by the arbitration of Louis Napoleon, when president of the French Republic, in favor of the British. Capt. Reid was made a sailing master in the U. S. navy, and in later years was also warden of the port of New York. For his connection with the U. S. flag see article FLAG. He also invented the signal arrangements formerly in use between Sandy Hook and the Battery in New York harbor. He died at New York, Jan. 28, 1861.

REID, WHITELOW, journalist, was born at Xenia, Ohio, in 1837. His father, a strict Covenanter, had been one of the founders of the town. Whitelaw graduated at Miami University in 1856 and entered the field of journalism. His brilliant letters to the *Cincinnati Gazette* signed "Agate" soon made him widely known. On the outbreak of the civil war he served as a volunteer aid in West Virginia, and was war correspondent with the Army of the Cumberland and the Army of the Potomac. At the close of the war he travelled throughout the South, and for a few months tried cotton-planting in Louisiana. He then became one of the proprietors of the *Cincinnati Gazette*, but in 1868 was called by Horace Greeley to be his associate in editing the *New York Tribune*. As managing editor he displayed force and skill in gathering news. When Greeley was nominated for the Presidency in 1872 the control of the paper was placed in Reid's hands, and there it has since remained through various changes of ownership. Having renewed cordial relations with the Republican party, he has made the paper a leading exponent of its policy. His books comprise *After the War* (1866); *Ohio in the War* (2 vols., 1868); *Memorial of Horace Greeley* (1873).

REINISCH, LEO, Austrian Egyptologist, was born at Osterwitz, Styria, Oct. 26, 1832. He was educated at Gratz and at the University of Vienna, and devoted himself to Egyptology. In this department of that university he was made professor extraordinary in 1868, and professor ordinary in 1872. He has made several journeys to Africa, and in 1865 with Lepsius he discovered the bilingual inscription at Tanis. In 1866 Reinisch accompanied the Emperor Maximilian's expedition to Mexico. Since 1873 he has devoted attention chiefly to the languages of East Africa, and has prepared several grammars and dictionaries of them which have been published by the Academy of Vienna. Besides several monographs on Egyptian subjects he prepared *Ägyptische Chrestomathie* (2 vols., 1873-75).

REINKENS, JOSEPH HUBERT, a German Old-Catholic bishop, was born at Burtseheid near Aix-la-Chapelle, March 1, 1821. He was educated at Bonn, and studied theology at Cologne and Munich, taking his doctor's degree at the latter in 1849. He began to teach history at Breslau in 1850, and became professor of theology there in 1857. He was also preacher in the cathedral from 1852 to 1858. In 1870, having published an essay on *The Pope and his Power according to St. Bernard*, he was warned by the Prince-bishop Förster, who also sought to hinder the publication of his treatise on *Papal Infallibility*. On August 26, at Nuremberg, Reinkens joined with Döllinger and others in a declaration against the Vatican Council. To the subsequent controversy Reinkens contributed some six pamphlets, which were collected under the title *The Papal Decree of July 18, 1870* (1871). At the Old-

Catholic Synod at Cologne in 1873 Reinkens was elected bishop, and was consecrated on August 11, at Rotterdam, by the Jansenist bishop Heykamp of Deventer. He was acknowledged by Prussia, Baden, and Hesse, and made Bonn his see. His oratorical ability was employed in extending the movement for some time with marked success. In September, 1876, he consecrated Bishop Herzog in Switzerland. Among his publications may be noted *Revolution und Kirche* (1876); *Ueber Einheit der Katholischen Kirche* (1877). He also published some treatises on *Clement of Alexandria* (1857), *Procopius* (1859), *Hilary of Poitiers* (1864), *Martin of Tours* (1866), *Aristotle on Art* (1870), *Louise Hensel* (1877), *Lessing on Toleration* (1883).

REIS, PHILIPP (1834—1874), a German physicist, regarded by some as the inventor of the telephone, was born at Gelnhäusen, Jan. 7, 1834. He was educated at Frankfurt and was employed in a color-factory there, but pursued with ardor mathematical and scientific studies. In 1858 he became a teacher in an institute at Homburg, and there constructed an instrument by which sound could be transmitted to a distance. This has been called the first telephone, though Reis did not use the name, nor did his contrivance transmit speech. Reis died Jan. 14, 1874, before any public interest was shown in his work. For a full account of his career and invention see the *Popular Science Monthly*, August, 1883, and *Philipp Reis*, by S. P. Thompson (London, 1883).

RELIGIOUS LIBERTY is a special application of the general law of personal liberty, which affirms the right of every man to exert his powers freely at the dictate of his own sense of duty or self-interest, restrained only by regard for the rights and just claims of others. As applied to mental action, the principle demands freedom of thought and of expression by speech or writing; and in the sphere of religion, freedom of opinion, of teaching, and of worship, implying the right, as before the law, to be of any or of no religion. But as religion has regard to men's supreme duty and interest, calling into exercise the deepest sense of obligation, religious liberty is the highest and most sacred form of personal liberty. Out of the recognition of personal religious liberty grows by a natural evolution the right of association. Persons of the same religious faith unite to form a church. Complete spiritual freedom includes the freedom of churches not only to maintain public worship but to establish terms of membership and rules of discipline. For the state to intermeddle with or impede the administration of church discipline would be a deprivation of the just liberties of its members. Religious liberty differs from toleration, with which it is often confounded. The power to grant toleration implies the power to refuse it. Thus the English Toleration Act, as originally framed, refused toleration to Roman Catholics and to Unitarians, and it was not till a recent period that those exceptions were removed. It is also to be distinguished from religious equality. To establish by law and maintain by general taxation any form of religion—so long as the free exercise of other religious forms is permitted—violates equality but is no invasion of religious liberty. In these definitions and distinctions, it may be necessary to state, liberty is viewed as the alternative of restraint imposed under forms of law. There are moral restraints which infringe no man's rights. One who advocates unpopular opinions must run the risk of becoming personally unpopular, involving various degrees of social isolation. This, however unpleasant to bear, is not persecution. Nor is it an infringement of any one's liberty to subject him to ecclesiastical censure according to the rules of the denomination to which he belongs by voluntary adhesion. But penalty, privation, or civil disqualification inflicted by law for the profession of any form of religion is a denial of religious liberty.

Personal liberty in all its forms, regarded as the

right of every man, is essentially a modern idea, and its recognition is still far from being world-wide. In the ancient civilizations all rights of the individual were held subordinate to the prerogative of the state. It was found that the absolutism of a popular assembly could be as oppressive as that of an emperor. Against the absolute state, whether republican or imperial, the individual had no rights. Christianity by its doctrine of personal duty, of personal redemption, and of personal responsibility to the divine judgment, attached an infinite value and dignity to every human soul, from which the acknowledgment of personal rights was a necessary though not an immediate inference. The hierarchical organization of the church, and its alliance with the empire, tended again to subordinate the individual to the catholic whole. Augustine gave the weight of his authority in favor of treating heresy as a crime against the state. The fatal precedent bore its fruit in making spiritual despotism the law of Catholic Europe. The Reformation carried in its bosom the spirit of revolt against ecclesiastical authority, but not positive faith in the freedom of the soul. The Reformed Churches, in close alliance with the state, continued the rule of intolerance, which was affirmed in their confessions of faith. The Formula of Concord, for example, declares concerning the Anabaptists that they "are divided into many sects, of which some maintain more, some fewer errors. Nevertheless, in a general way, they all profess such a doctrine as can be tolerated neither in the church, nor by the police, nor in daily life (*neque in Ecclesia, neque in politica, neque in aconomia tolerari potest*). The First and Second Helvetic Confessions fulminate in like manner against all who bring in or follow "strange doctrines." The French and Belgic Confessions are equally explicit; the Scotch Confession of 1560 goes so far as to affirm that to kings, princes, rulers, and magistrates *chiefly and principally* pertains the conservation and purgation of religion, and that they are appointed for the maintenance of true religion and for suppression of idolatry and superstition. The Westminster Confession, with its characteristic fulness of thought and terseness of expression, declares that "the magistrate hath authority and it is his duty to take order that unity and peace be preserved in the church, that the truth of God be kept pure and entire, that all blasphemies and heresies be suppressed, all corruption and abuses in worship and discipline prevented or reformed, and all the ordinances of God duly settled, administered, and observed." The Presbyterian Church in the United States has not received this article of the Confession of Faith, but substituted for it another, more in harmony with the spirit of the later age. The Church of England was a persecuting church, with rare intervals, for three hundred years.

From the bosom of the English church came forth bodies of dissenters, now numerously represented among the popular forms of ecclesiastical life. The Independents (or Congregationalists) protested vigorously against the intolerance of the Established Church. When, in consequence of the Parliamentary War, Episcopacy was suppressed and the Westminster Assembly was called to frame a new ecclesiastical constitution for Great Britain, their Confession of Faith and Form of Government were summarily set aside by the Independents, aided by the weight of Oliver Cromwell's sword. Yet, under the Protectorate, though there was a general toleration, there were significant exceptions. The lenity of the government did not extend to Roman Catholics or Unitarians. Nor was this merely a matter of civil regulation. The Independents had no idea of countenancing any doctrine of complete religious freedom. John Robinson has been canonized by the descendants of the Puritans as a Liberal born out of due time. Yet John Robinson, in several publications, insisted on the duty of the magistrate to maintain true religion and put down religious error. "He may"—such is his remarkable

statement—"alter, devise, or establish nothing in religion otherwise than as Christ hath appointed," but may "use his lawful power lawfully for the furtherance of Christ's kingdom and laws. . . It is true, they have no power *against* the laws, doctrine, and religion of Christ, but *for* the same, if their power be of God, they may use it lawfully and *against* the contrary." A government holding what he thought to be the truth, in his judgment, was authorized to maintain it by force. Macaulay scarcely caricatured this theory when he said: "The doctrine which, from the first origin of religious dissensions, has been held by all bigots of all sects, when condensed into a few words and stripped of rhetorical disguise, is simply this: I am in the right and you are in the wrong. When you are the stronger you ought to tolerate me; for it is your duty to tolerate the truth. But when I am the stronger, I shall persecute you; for it is my duty to persecute error." But the light was struggling with the darkness. It has been claimed that Robert Browne, from whom the Independents received the nickname of Brownists, in 1582 affirmed the doctrine of complete religious liberty. The language of Browne is not so unambiguous as could be desired, and he himself returned to the Established Church, and his doctrine, whatever it had been, received no further support from him. A more decisive and outspoken publication was issued in 1614, bearing the title, *Religious Peace: or, a Plea for Liberty of Conscience, presented to King James and the High Court of Parliament by Leonard Busher, citizen of London*. Busher was a Baptist, and in this attitude he was not singular among his brethren, for already in 1611 a Baptist *Confession of Faith* had been put forth containing this declaration: "The magistrate is not to meddle with religion or matters of conscience, nor compel men to this or that form of religion; because Christ is King and Law-giver of church and conscience."

The next representative of the principle is Roger Williams, who was banished from Massachusetts in 1638 for maintaining it, and who has the honor of being the first legislator to make it part of the fundamental law of a state. Baneroff, in his *History of the United States*, represents him as the first asserter of the doctrine, an honor which cannot be claimed for him in the light of history. He was a stalwart defender of the principle against Rev. John Cotton, who assailed it. The growth of the American colonies was marked by a vigorous growth of sentiment favorable to the fullest civil and religious liberty and a passionate attachment to it. Under the lead of Franklin, whose liberality in several directions placed him in advance of his age, and of Jefferson, who is justly venerated as the father of religious liberty in Virginia, this became the prevailing spirit of American thought.

The legislative history of religious liberty is a history of crimes against it, and of painfully slow concessions to its spirit. Holland was the first of modern states to establish the policy of toleration, which is the nearest approach to religious liberty known to Europe. Queen Mary of England, the Roman Catholic, is sadly immortalized as the "Bloody Mary" for her sanguinary persecution of Protestants. But Queen Elizabeth, the Protestant, made a sanguinary persecution of Roman Catholics; and she and her successors until the Revolution of 1688—Cromwell excepted—kept the Protestant nonconformists under the pressure of the most abominable penal laws. The attempt to impose Episcopacy upon Presbyterian Scotland more than once brought the kingdom to the brink of civil war. The original Toleration Act, of 1689, grudgingly passed and loaded with invidious restrictions and exceptions, has been, by gradual amendment, made so ample in its provisions that, while its original theory is unretreated, it practically amounts to entire religious freedom. On the conti-

nent of Europe toleration is the general rule, but there are some exceptions. France now tends towards a complete secularization of the state. The Spanish constitution provides for toleration, but the administration locally falls short of redeeming the promise. The same is true of Austria and of some of the German states. The gloomy autocracy of Russia is as severe and unbending in the ecclesiastical as in the civil sphere.

A New World was needed for the full growth of the new idea. For both the theory and the practice of religious liberty and of religious equality we must look to these United States, of which the first to profess and act upon it was, as we have seen, Rhode Island. Maryland was founded on a policy of liberal toleration, but the charter contained no sufficient guaranty of it, and the subsequent legislation of the colony at one time leaned to a contrary policy. Pennsylvania was the next in succession to grant liberty of conscience, which was essentially involved in the Quaker theory of religion professed by its founder. Virginia had originally an established church with some of the intolerance of the mother church of England at that period, but under the combined action of religious dissent and of religious indifference its power was curtailed, and when the State constitution was formed, its Bill of Rights became the recognized creed of civil and religious liberty for all the States. It was copied in other State constitutions and in the first ten amendments to the Constitution of the United States. Massachusetts, under her colonial charter, was as intolerant as any Roman Catholic state. We have seen Cotton defending a persecuting policy against Roger Williams. When Gov. Dudley died, in 1653, there were found in his pocket some lines of verse, which included the following:

"Let men of God, in courts and churches, watch
O'er such as do a toleration hatch,
Lest that ill egg bring forth a cockatrice,
To poison all with heresy and vice.
If men be left and otherwise combine,
My epitaph's, 'I died no libertine.'"

When Cromwell was proposing toleration in England, a synod in Massachusetts protested against the measure as "licentious." Nathaniel Ward, pastor at Ipswich, published in England his *Cobbler of Agawam*, fiercely denouncing it. "I lived," he says, "in a city where a Papist preached in one church, a Lutheran in another, a Calvinist in a third; a Lutheran one part of the day, and a Calvinist the other, in the same pulpit. The religion of that place was but motley and meagre and their affections leopard-like." He insisted on the old maxim, that religion is *ignis probationis*—a test of fire. It is an interesting study to trace the successive steps by which from this condition of public sentiment Massachusetts became the home of religious liberty and equality. The principle is at length rooted in the convictions of the American people. With every advance in popular government, in the Old World as in the New, the emancipation of the intellect and the conscience keeps pace with the general progress.

The constitutional defences of religious liberty in the United States are not as complete as they are popularly supposed to be. The Constitution of the United States provides (Article I. of Amendments) that "Congress shall make no law respecting an establishment of religion or prohibiting the free exercise thereof." This, however, imposes no restriction upon the States, and it is well known that at the time of the adoption of this article there were in more than one State religious establishments. Connecticut, in 1818, disestablished her Congregational churches. Massachusetts followed, but not till 1833. The State constitutions all contain provisions guarding the rights of conscience and establishing religious equality. But State constitutions are amended with facility, and, as

the question of their amendment is local, it is conceivable that in very possible contingencies a State might efface the provisions that recognize religious freedom as among the inalienable rights of man. Experience has shown that political alliances with churches are more likely to be made by State and city governments than by the government of the United States. Payments might be made from a city treasury to a favored church without attracting any wide public attention; and, on the other hand, a church might secure virtual control of local governments, manipulating them for its purposes. As only the State constitutions stand between the people and such betrayal of their rights, it is worthy of consideration whether additional security is not possible and desirable. An amendment to the Constitution of the United States, to the effect that "No State shall make any law for the establishment of religion, or prohibiting the free exercise thereof," thus extending to the States the restriction now imposed upon Congress, would be a wholesome preventive of insidious local encroachments upon the public liberties. The Constitution now provides that the United States shall guarantee to every State a republican form of government. A further guarantee to the people of every State against interference with the free exercise of religion would put the essential rights and immunities of the citizen under the guardianship of the whole nation. But the most perfect definitions of rights, and the most precise limitations of power, will be ineffective without an intelligent love of freedom on the part of the people, and a firm resolution to maintain it. In the last resort, constitutional law expresses only the fixed determination of the popular will.

On the general subject see Schaff's *History of the Christian Church*, Vol. VI., p. 51, *sq.*; Jeremy Taylor's *Liberty of Prophecy*; John Stuart Mill's *On Liberty*. The treatise of Leonard Busher, above referred to, has been republished in the collections of the Hansard Knollys Society, England. The treatises of Roger Williams have been reprinted by the Narragansett Club, Providence. As to Robert Browne, see *Congregationalism as Seen in its Literature*, by H. M. Dexter, p. 101, *sq.* The case of Massachusetts *vs.* Roger Williams is ably stated in Palfrey's *History of New England*, Vol. I., p. 405, *sq.* For a striking view of the fathers of New England, see Bushnell's *Work and Play*, p. 124, *sq.* (L. E. S.)

RENAN, JOSEPH ERNEST, French philologist and writer, was born at Tréguier, in the Department Côtes du Nord, Feb. 27, 1823. His parents, pious Catholic peasants, destined him to the priesthood and sent him to the college of his native town. His talents attracted attention, and he was invited to pursue his studies in the Seminary of St. Sulpice, at Paris, then presided over by Abbé Dupanloup, afterwards Archbishop of Bordeaux. He devoted himself with eagerness to the Semitic languages, under Abbe Le Hir, to whom he pays tribute in his *Souvenirs*. But his philological studies caused him to lose faith in Catholic dogmatic theology. In October, 1845, he left the seminary and sought to support himself by giving private instruction. His sister, a governess, came to his aid, and gave him 1200 francs, her entire savings. In 1848 at an examination for a fellowship in philosophy he took the highest rank, and the Institute awarded him the Volney prize for a dissertation on the Semitic languages. In 1849 the Academy of Inscriptions sent him on a literary mission to Italy, where he obtained materials for an important work on Arabic philosophy, *Averroès et l'Averroïsme* (1852). Another work of the same time on the Greek of the Middle Ages was crowned by the Academy. In 1851 Renan was installed in the manuscript department of the National Library. In 1856 he was chosen a member of the Academy of Inscriptions. Within a few years he published a translation of the Book of Job, with an essay on its age and character (1858), and a similar work on the Canticles (1860). He had been

also a diligent contributor to reviews and periodicals, and from these he had collected two volumes, *Études d'histoire Religieuse* (1857); *Essais de Morale et de Critique* (1859).

In 1860 the French government sent an army to Syria and in accordance with precedent sent also a scientific commissioner to that ancient land. To Renan, as the foremost Semitic scholar, was afforded the opportunity of exploring Tyre, the Lebanon, and Palestine. On his return he was appointed professor of Hebrew in the Collège de France, but his introductory lecture was attended with such disorder that the course was suspended. In 1864 he was dismissed after the appearance of his famous book, the religious result of his visit to the Holy Land, the *Vie de Jésus*. The work circulated with astonishing rapidity, but the outcry against it was most vigorous. Duruy, the minister of public instruction, tried to conceal the removal from the professorship by appointing him to a position in the Imperial Library, but Renan refused to accept. After the downfall of the Empire he was restored on the unanimous request of the faculty of the Collège and of the Institute. In 1883 he was made administrator of the college. His wife and daughter have cheered him in later life as his sister did at the commencement of his career.

The *Vie de Jésus* was intended to be the introduction to a history of the origin of Christianity. This design was carried out in *Les Apôtres* (1866); *Saint Paul et sa Mission* (1867); *L'Antéchrist* (1873); *L'Église Chrétienne* (1879). He published also official reports of his mission to Phœnicia, discussions of Oriental and archæological subjects, and contributions to the literature of the day. The latter were partly collected under the title, *Questions contemporaines* (1868). In 1878 Renan was elected to the French Academy, and in his inaugural address in April, 1879, he touched with trenchant satire certain defects in German scholarship and literature. In 1880 he became an officer of the Legion of Honor, a position from which the obstinacy of Pres. MacMahon in refusing to sign the decree had excluded him for months. In the same year he delivered the Hibbert lectures in London, taking for his theme *The Influence of Pagan Rome on Christianity*. Closely connected with these is his *Marc Aurèle et la fin du monde antique* (1881). Renan has written charming autobiographic sketches under the title, *Souvenirs d'Enfance et de Jeunesse* (1883), which have appeared in English as *Recollections of My Youth*. Some dramas from his pen in later years appear to indicate a depraved imagination. His latest works are 1802, a panegyric of Victor Hugo (1886), and *Discours et Conférences* (1887).

The *Vie de Jésus* totally ignores any divinity in the Founder of the Christian religion, yet some critics have regarded it as an elaborate tribute to his character. It was utterly different from the mythical theory propounded in Strauss's *Leben Jesu*, but it was a more insidious attack on Christian belief. Combining his own youthful experience in Brittany with his mature study and sympathetic observation of Oriental life and scenery, Renan presents Jesus of Nazareth as a Jewish philosopher of mystical tendency; in fact, what he himself might have been had he lived in the Roman province of Judæa. The central figure moves under the brilliant light of a cloudless Eastern sky. The consummate art of the portrait seems but the poetic rendering of the truth of nature. Yet the picture remains French in its idea, its accessories, and its limitations. It has the feminine tone characteristic of French emotion. Worst of all, while professing love for the person of Jesus and reverence for his character, it taints his moral purity. The intense and deadly hostility of the attack on Christianity was felt at once by both friend and foe. All France, and soon all Europe, was roused, and numerous replies to the work, of various degrees of ability, were prepared. Yet outside of France it has had little real effect and

the later works for which it led the way are but little known and seldom named. Infidels of other nations demand a coarser and stronger polemic against Christianity. But in France the exquisite grace of Renan's style and the charm of his poetic fancies will enable him to hold a foremost place among her writers.

(J. P. L.)

RENO, JESSE LEE (1823-1862), general, was born at Wheeling, W. Va., June 20, 1823. Appointed cadet from Pennsylvania, he graduated at West Point Academy in 1846, and entered the ordnance department. He was engaged in the Mexican war, and by his gallantry won brevets at Cerro Gordo and Chapultepec, being wounded at the latter. He was afterward assistant professor of mathematics at West Point, and was employed in the Coast Survey and on other duty. He was ordnance officer in Gen. A. Sidney Johnston's expedition to Utah. On the outbreak of the civil war he remained faithful in his allegiance, and in November, 1861, he was made brigadier-general of volunteers. He took part in Burnside's expedition to North Carolina, fought at Roanoke Island, and assisted in the capture of New Berne. In July, 1862, he was ordered to reinforce McClellan's army, and he afterward joined Gen. Pope's army. Having command of the Ninth Corps, he fought near Manassas. When McClellan was again appointed to the chief command, Reno was in the advance and engaged the enemy at South Mountain, Md., Sept. 14, 1862. By his gallantry and activity he contributed to the victory, but was killed before the close of the day.

RENOUF, PETER LE PAOE, an English Orientalist, was born on the Island of Guernsey, in 1824. He was educated there at Elizabeth College and afterward at Pembroke College, Oxford. In 1842 he became a Roman Catholic, and when the Catholic University of Ireland was opened in 1855 he was made professor of ancient history and Oriental languages. Here he also assisted in editing *Atlantis* and the *Home and Foreign Review*. In 1864 he was appointed an inspector of schools, and held this position for many years. His work on *The Condemnation of Pope Honorius* (1868) was attacked by the Roman Catholic press and was placed on the *Index*, but Renouf maintained and defended his position. He had previously published some controversial works, but his principal work has been in Egyptian philology. He delivered the Hibbert lectures in 1878 on *The Ancient Religions of Europe*. In 1885, on the death of Dr. Samuel Birch, Renouf was appointed keeper of the Egyptian antiquities in the British Museum.

RENWICK, JAMES (1790-1863), physicist, was born at Liverpool, England, May 30, 1790, but was early brought to New York city. He graduated at Columbia College in 1807, with the highest honors, and in 1810 he returned to lecture on natural philosophy. In 1817 he was made a trustee of the college, but in 1822 he resigned that position on being appointed professor of experimental philosophy and chemistry. He did much to diffuse in the United States the knowledge of natural sciences by his textbooks. His *Outlines of Natural Philosophy* (2 vols., 1832) was the first important treatise on that subject in this country, and his *Outlines of Geology* (1838) had a similar precedence. He also published *Elements of Mechanics* (1832) and *Practical Applications of Mechanics* (1840). His *Treatise on the Steam-Engine* (1840) was highly esteemed as a practical guide. In the field of biography he was also a diligent laborer, preparing *Lives of Fulton, Rittenhouse, Count Rumford, De Witt Clinton, Jay, and Hamilton*. In 1838 he was one of the U. S. Commissioners appointed to explore the region of the North-East Boundary. In 1853 he resigned his professorship, but continued in other ways his labors for the advancement of science and its practical applications. He died at New York, Jan. 12, 1863.

His son, **JAMES RENWICK**, born Nov. 3, 1818, gradu-

ated at Columbia College in 1836, and became a civil engineer. He was engaged in work on the Erie Railway and the Croton Aqueduct. Afterwards becoming an architect, he constructed Grace Church, St. Patrick's Cathedral, the building of the Smithsonian Institution, the Corcoran gallery at Washington, Vassar College, and other buildings.

REPRESENTATION. Popular governments, in which the mass of the people of a community participate in the exercise of public authority, usually exhibit two methods of exercising such popular function. In small communities the direct participation of the people in the enactment of laws and the control of administration, acting together in public assemblies, is practicable and frequently exists, but where the numbers participating in such government exceed what could be conveniently assembled for such purpose, and where the distances to a place of common meeting are too great to admit of the assembling of a considerable portion of the citizens, the necessity exists for delegating authority to certain selected persons to perform such duties in the name and with the authority of such community. The persons thus selected for the purpose of enacting laws to regulate the affairs of the community are designated representatives, and the relation in which they stand to the citizens from whom their authority is derived is expressed by the term representation.

Every agency in which one acts in the name and with the authority of another is an instance of representation, in the general sense of the term, but political agencies attended with a delegation of authority to make laws are properly expressed by the term representation in its institutional sense. According to general usage, this implies a legislative body consisting of representatives who deliberate and act together, in one or more assemblies, by the votes of some predetermined number or proportion of the whole assembly. Governments in which the whole body of the citizens act together directly in the enactment of laws are described as pure *democracies*, while those that have legislative bodies composed of representatives chosen by the people are designated as representative popular governments, and very commonly as *republics*.

While the theoretical origin of representation traces the institution to the necessities of large and populous communities sustaining popular institutions, the historic origin is in the causes that transferred the source from which legislative authority was derived from monarchs, dignitaries, and privileged classes to the body of the people or some considerable part of that body. In the great governments of Europe the admission of the citizen to the individual right of participating in the choice of representatives is of modern origin, and was preceded by the indirect exercise of that right as a member of some municipality or other political community or of some organization of a mixed political and industrial character. Popular representation owes its establishment largely to the necessities of the governing classes for money, and the struggle by which in England it obtained definite and fixed recognition has associated together the ideas of taxation and representation as having a peculiar connection, while in an accurate sense all the powers of government are equally related to representation as the proper means of their exercise.

Popular representation in America was directly derived from the English system transferred to this country and implanted in the first colonial governments. The condition of the colonies admitted of no other system conformably to the customs of England, as the populations of the colonies were scattered over wide areas and were homogeneous and without class differences to serve as the foundation of oligarchical institutions. From the colonial governments popular representation passed into the government of the United States and of the respective States under the Articles of Confederation, and thence into the existing

governments of the United States and of the States at the formation of the Constitution.

We find in examining the representative system as it exists in the United States two modes of representation, both of which may be termed popular, but differing from each other as direct and indirect. The representation in the House of Representatives of the Congress of the United States is of the direct kind, while that in the Senate of the United States is indirect. In both cases the people of the States are the sources from which the representation is derived, but in the one case they exercise a direct choice of the representatives through a popular election, while in the other that choice is made by the Legislature of the State, and yet as that Legislature is the product of popular election, it may still be regarded as popular in its nature although indirectly exercised by the people.

The members of the U. S. House of Representatives are chosen by the people in congressional districts, each State being subdivided to make such districts. The Senators, on the other hand, are chosen by the Legislatures of the several States. The congressional districts from which members of the House of Representatives are chosen are not organized communities, but merely geographical divisions of population. As the people of these districts do not act together as a distinctive community, exercising municipal power, it is to be concluded that their choice represents a collective body of individual preferences. On the other hand the selection of the U. S. Senators is the act of the agents of government of a State, chosen by the people of the State for objects having direct relation to the local interests of such State. It will be found, when considering the representative system of certain of the States, that the U. S. House of Representatives has a more distinctly popular character, as proceeding directly from popular choice, independently of the effects of local organization, than prevails in the legislative bodies of the States, and that the Senate of the United States is the only legislative body in the United States that is based upon the governmental action of organized communities.

Of these two methods of deriving representation that which proceeds from the action of organized communities through their local governmental agencies appears to be that most intimately related to forms of government that preceded popular institutions. Such modes of representation are found in federated states that have a common administration of such interests as are in common among them, and indeed prevail where independent states are represented in consulting bodies acting in the common interest. This mode of representation although popular, as based on popular selection, may be termed *federal*, for although the term federal in its origin expressed the idea of authority derived from a compact or contract, still in its modern use it is applied to relations between organized communities of a governmental nature bound together by a national tie.

We find that, in the early constitution of the British House of Commons, cities and boroughs were distinctively represented as municipal bodies, and that direct popular representation in that body has been the product of the development of liberal ideas in later times.

When the whole people of an organized community that is part of a more general government vote collectively in the choice of representatives to exercise the powers of such general government, it is evident that the local interests of such community will be reflected in the choice made by them to a much greater degree than where such community is subdivided upon geographical rather than upon political lines into districts, each district exercising independently of each other a collective choice of such representatives. While a State or lesser community may maintain a certain line of policy as a whole, it is not to be anticipated that that policy will express the preferences of

each of the various geographical subdivisions into which it may be divided. A choice that rests upon the action of an organized community through its governmental agents may be said to be based upon corporate opinion, while that which proceeds directly from the people, independent of corporate organization, may be said to represent individual opinion. That communities in their organic action do not accurately represent the consequences of individual opinion and sentiment prevailing among their people is commonly observed. Material interests are apt to dominate social ideas in what is here termed corporate opinion, while a better opportunity for the expression of social ideas and tendencies is afforded by direct individual action.

It is apparent from what has been said that the tendency, that is observed in popular governments, to reach a direct expression of individual opinion serves to enhance the social influences as distinguished from those of a material character, while the conservation of methods intimately connected with corporate opinion tends to give coherence to the system, thus combining together progressive and conservative tendencies to produce that dualism without which society would be incomplete.

As has been observed, the constitution of Congress utilizes both of these sources of influence each in its most vigorous form. In the constitution of the legislative bodies of the States of the Union the same general truths are observed, but less distinctly expressed. In Massachusetts the representation in the House of Representatives is based upon the towns, while that of the Senate rests on towns united to form districts, but the choice of representatives proceeds from the people of the towns, and not from their corporate authorities. While this is an instance of direct popular choice, the compact organization of the towns, and the close relation of the action of the town authority to the interest of the people, tend strongly to color the popular choice with the qualities of the prevailing corporate opinion. In New York the legislative representation is based upon counties, the counties being subdivided for the choice of members of Assembly, and united to form districts for the election of senators. The counties of New York are much less compact bodies than the towns of Massachusetts, affecting the interests of the people in a much more limited way, and hence it would follow that individual tendencies would, as compared with corporate tendencies, be more effective in New York than in Massachusetts. The subdivisions of the counties in New York for the formation of districts for the election of representatives to the popular branch of the Legislature tend to give expression to neighborhood interests and opinion, and thus individual opinion is brought under the influence of limited local causes.

The instances of Massachusetts and New York may be taken as the types of the systems prevailing throughout the United States, the former principally in New England, and the latter throughout the rest of the United States. It has already been remarked that neighborhood opinion is a factor where small election districts are created, and this affords the reason for the statement already made that representation in the U. S. House of Representatives has a more direct relation to generalized popular opinion than in any of the systems prevailing in the States. The large territorial extent of the congressional districts cancels the influence of neighborhood opinion, while the fact that such districts have no corporate existence for municipal purposes tends to exclude the domination of corporate opinion, and the result is, or should be, a clearer approximation to a fair generalization of individual opinion. Methods of selection and the influence of party action may and do change these results, but the tendencies nevertheless exist and continue to act, and in long periods of time will produce their proper results. The government of the United States, considered

as embracing the systems of the States, generalizes all the sources of influence that have been described as corporate, individual, and neighborhood opinion; stated in other language, these include the influences of organized communities, the tendencies of popular sentiment and opinion, and the phase of influence that arises from small and homogeneous districts. Such composite structure of government is undoubtedly demanded by the nature of popular government to modify the result of popular activities without putting restraint upon them. Indeed it is doubtful whether permanent stability may be attained by popular institutions in large communities independent of the federal principle that utilizes all the sources of influence.

In popular governments the choice of representatives proceeds through some form of election, of which there are in use two forms, one calling for an oral expression of choice and the other in which such choice is evidenced by writing or printing. The former of these methods is in limited use and only suited for small and homogeneous communities, while the latter, under the name of voting by ballot, is in most general use, principally for the reason that it admits of the act of voting being performed in a secret manner, thus exempting the voter from responsibility other than to his own sense of duty or interest. Such acts of election are habitually supervised by official persons, whose statements of the result are accredited as entitling the representative certified by them as elected to claim his seat in the legislative body to which he is elected. The ultimate right to determine the sufficiency of such election is in this country habitually in the legislative body, while the elections to the English House of Commons are determined judicially by the courts. The consequence of the mode of determining such questions prevailing in this country is that such questions are more frequently determined on political grounds than in a judicial spirit.

The relation of the representative to his constituents, as it regards his duty of conforming to their opinions and desires in the exercise of his functions, has given rise to much difference of opinion, and is likely to remain a subject of speculative opinion for the want of tribunals competent to bring it to a final solution. In many of the States, as already noticed, the right of the people to instruct their representatives is directly conferred by the State constitutions. The construction of these clauses cannot come into the courts under ordinary circumstances, and they must remain to be expounded by the slow process of the formation of public opinion. It is hardly to be supposed that the expression, *instruction*, as there used was intended in the sense of a binding requirement, but rather as an equivalent of *information*. For the people to instruct their representatives, in the sense of laying them under obligations to act in a particular way, would require that they should act collectively, the whole people of the community participating, as in a convention of the whole people or their selected delegates; but it is not to be presumed that such was the intention of those constitutions that secure to the people the right to instruct their representatives. These clauses are intimately interwoven with others very clearly intended to secure individual rights and the rights of collective bodies of persons less than the whole community, and associated together merely by a common opinion or interest on certain subjects; and certainly individuals and irregular collective bodies were not intended to have a controlling influence on the action of the representatives of the whole people. Where the duty of a representative is pointed out by a clear obligation to the whole community, it is quite plain that it should not be controlled by a portion of that community less than its majority.

That the representative should bring to the attention of the legislative body the sentiments and opin-

ions of the local constituency represented by him seems to be generally conceded; and clearly, where they have a peculiar interest affected by public measures, that interest should be represented and protected by their representatives, unless overborne by superior interests affecting the whole community. While it would seem that so important a feature of a popular system of government as that which relates to the duty of the representative in view of the known wishes of his constituents should be reduced to something like an exact understanding, yet the formation of a common opinion upon the subject is by no means an easy matter under the simplest conditions of such relation, but is seriously complicated through the division of responsibility incident to party organization, which in popular governments appears to be the natural consequence of the effort of opinions and interests to reach the condition of a public policy. (A. J. W.)

REPUBLICAN PARTY. The failure of the two great American political parties, Whig and Democrat, after earnest efforts for a quarter of a century to settle the slavery question by such compromises as would be satisfactory to both North and South, resulted ultimately in the disintegration of the former party and the formation of a new political organization. All attempts at conciliation through legislation were fruitless of satisfactory results, as the Democrats refused to surrender what they claimed as rights under the Constitution and laws that affected the slavery question. Outside of the Abolitionists (*q. v.*), who had never become a prominent factor in politics, the legal right to hold slaves in the several States where slavery existed was not denied, but the question that agitated the public mind at the middle of this century was whether the area of slavery should be extended into the Territories.

The repeal of the Missouri Compromise, which had interdicted slavery north of latitude 36° 30', made Kansas the battle-ground, and the friends of either side exerted themselves to populate and protect that Territory with those of their own political faith. The right of the slaveholders to take their slaves with them into that Territory was denied by the Free State men, on the ground that slavery was a local institution and must be confined to the States where it already existed. On the other hand, the slaveholders claimed the right, inasmuch as slavery was virtually recognized by the Constitution, to carry their slaves to any part of the United States as they could any other property. Thus this question became a direct issue which in the fulness of time brought the Republican party into existence. The Freesoilers of the North formed its advanced guard, and the old Abolition party fell into its ranks.

Public discussion both in and out of Congress, instead of quieting the discordant elements, increased their intensity, and party lines became more rigidly drawn than before. The Whig party won its last national victory in 1848 through a partial coalition with the Freesoilers, but after the death of Pres. Taylor in 1850 Fillmore notably changed the policy of the administration. The Whig party had become effete by its repeated and futile attempts at compromise, while the Free Soil party was young and aggressive, and was founded on a vital issue. When the disintegration took place, the Southern pro-slavery portion drifted to the Democrats, while the anti-slavery Whigs in the North still opposed its old political foe. The presidential campaign of 1852, the last in which the Whig party figured in national politics, was only an exhibition of its weakness. In its platform it was silent on the slavery question, with the exception of an indorsement of the Fugitive Slave law which had been enacted by the Thirty-second Congress. This absurd silence at a time when the public mind was absorbed by the slavery question tended to make its decay more certain and rapid. It received only 42 out of 296 electoral votes.

In marked contrast with the Whigs, the Free Soil party took strong grounds, declaring against any more

slave States or new slave Territories, or the nationalization of slavery or extradition of slaves. It denounced the Fugitive Slave law and demanded its repeal. It alleged further that no permanent settlement of the slavery question could be had except in the practical recognition of the truth that slavery was sectional and freedom national. As an independent party, it refused to coalesce with others, but declared its object to be to defeat both Democrats and Whigs, which it said were hopelessly corrupt. Its motto was "Free Soil, Free Speech, Free Labor, and Free Men."

The Kansas-Nebraska controversy made a rupture in the old Whig party that could not be healed, and the Republican party, then in its incipiency, was augmented by the anti-slavery Whig elements. This shift was precipitated by the act of May 25, 1854, which provided a territorial government for Nebraska, which then included what is now Kansas. The struggle for Kansas was the throes of the birth of the Republican party.

The first national convention of the Republican party was held at Philadelphia, June 18, 1856. It was composed of delegates selected under a call addressed to the people of the United States, without regard to their former political creeds or opinions. It invited all those opposed to the repeal of the Missouri Compromise, to extending slavery into free territory, and in favor of admitting Kansas as a free State. It was intended to consolidate the opposition to the Democratic party. The personnel of the party was composed of Whigs with anti-slavery opinions, Abolitionists, Native Americans, and Independent Democrats—in short, of all elements opposed to the pro-slavery Democracy. It proposed, to harmonize these elements in a common cause, to settle the question of the extension of slavery by an appeal to the ballot-box.

In the platform on which the campaign was conducted appeared the following resolution: "That we deny the authority of Congress, of a territorial legislature, of any individual or association of individuals to give legal existence to slavery in any Territory of the United States, while the present constitution shall be maintained." This resolution announced the issue which called the new party into existence. The platform embodied the first principles of American liberty; it maintained the doctrines enunciated in the Declaration of Independence; the preservation of the Federal Constitution; the preservation of the rights of the States; and the Union of the States. It arraigned the administration of Pres. Pierce for its efforts to thrust slavery on the people of Kansas, and demanded the immediate admission of Kansas as a free State. It called for the extinction of polygamy, then rampant in Utah. It advocated aiding the construction of the Pacific railroad; favored liberal appropriations for improvement of our rivers and harbors; and declared in favor of restoring the national policies of Washington and Jefferson. With this creed, the Republican party started out on its mission.

The convention nominated John C. Fremont for President, and William L. Dayton for Vice-President. In November, 1856, more than 4,000,000 votes were cast, being an increase of about 30 per cent. over the previous presidential election. The result showed a surprising strength for the new party. Although James Buchanan, the Democratic candidate, was elected, having received 174 electoral votes against 114 votes for Fremont, and 8 votes for Fillmore, he was in a minority of 377,608 on the popular vote. Fremont received 1,311,231 votes, and Fillmore, 874,534 votes. It is highly probable that without a third party in the contest the Republicans would have elected their candidate.

The elections in 1856 drew party lines more tightly, and incited both political elements to renewed exertions for supremacy. Buchanan's election was a present triumph for the South, but a comparison of the vote with that of four years previous gave his party un-

business and the Republicans hope for the future, for while the Democrats had a plurality of 60 in the electoral college, the popular vote was against them. In 1852 they had a popular majority of about 59,000, and had 212 votes in the electoral college. This change in public sentiment gave the Republicans prestige in their defeat, made them more aggressive, and gained them new acquisitions. This is shown by the address issued Nov. 27, 1856, congratulating the Republicans on their work in the past and urging them to renewed efforts in the future. The address pointed to the fact that in 1852 the Democratic party carried all the States, except four, on the popular vote, while in 1856 they lost eleven States, containing half the population of the Union, and that the Republican candidate received nearly three times as many electoral votes as the Whig party had in 1852, and that it already controlled fourteen of the State governments. As the issues still remained, it was evident that the Republican party would be a formidable antagonist in 1860.

A continuous chain of events favored the new political organization, among which the celebrated Dred Scott case (*q. v.*) stands prominent. The decision in this case not only intensified the feeling throughout the North amongst those already connected with the Republican party, but it also added to its numbers many Democrats who had anti-slavery convictions. This decision denied that which many in the non-slaveholding States claimed, and which they intended, if possible, to secure—the right of Congress, and of the people of a Territory, to control the extension of slavery. It ordained slavery as an irreversible condition; it made slavery national and freedom sectional. What tended to increase popular feeling was the statement that the final decision of the court was the opposite of its original opinion. [Justice Benjamin R. Curtis tendered his resignation to the President because the court first decided the case upon one ground and afterwards agreed to reopen it and decide it on another, which he considered subversive of law. This action destroyed his confidence in that body, and he refused to continue on the bench under those circumstances.]

This famous decision, which was given only two days after Pres. Buchanan entered on office, and which was intended to quench the Kansas struggle, only added fuel to the flame. As a result, war and bloodshed marked the attempts of the two parties to control the incipient State. The election for members of the Legislature was attended with fraud and violence. The Free State adherents held a convention at Topeka to frame a State constitution, but Congress after a fierce struggle refused to admit it as a State. Popular feeling ran high all over the country. The result of the long congressional struggle was simply this: "That Congress was neither to legislate slavery into any Territory or State, nor to exclude it therefrom; but to leave the people thereof perfectly free to form and regulate their domestic institutions in their own way, subject only to the Constitution of the United States, and it was specially prescribed that when the Territory of Kansas shall be admitted as a State, it shall be admitted into the Union with or without slavery as the constitution adopted should prescribe at the time of admission."

What is known as the Lecompton Constitution was subsequently submitted to Congress by Pres. Buchanan in 1858, with a message saying: "Slavery exists in Kansas by virtue of the Constitution of the United States;" and he urged that body to admit it as a State under that Constitution. At a special election the people of Kansas decided by a majority of 10,000 votes not to accept admission under that Constitution. It remained a Territory until 1861, when it was admitted by a Republican Congress under its "free" constitution adopted in 1859.

These events with others intimately related to them

prepared the way for the presidential contest of 1860, and at the same time consolidated the opposition to the policy of the Democratic party. The anti-Lecompton Democracy could not consistently return to the old party, and they were not ready to unite with the Republican party, which had refused to adopt the doctrine of "popular sovereignty" advocated by Stephen A. Douglas. This was a feeble compromise, and would have been fatal to the new party. A backward step would have caused a division in the party, as it would be a surrender of the principle on which it was founded—the non-extension of slavery. In the memorable Douglas-Lincoln debate in 1859 it became evident that popular sovereignty could not be accepted by the Republicans, for the repeal of the Missouri Compromise had placed them in an advanced position. That celebrated discussion and the Kansas troubles did more to consolidate the anti-slavery element than anything which could have happened. The people recognized the irrepressible conflict between freedom and slavery and accepted the words of William H. Seward that "the United States will, sooner or later, become either an entirely slave-holding nation or an entirely free-labor nation."

This was the condition of national politics when the Democrats met in convention at Charleston, April 23, 1860. The Douglas element stood firmly by the doctrine of popular sovereignty, while an almost solid South stood by the Dred Scott decision. This resulted in a double set of resolutions, and that of the Douglas wing was adopted by a majority of 27 votes. After 54 ineffectual ballots the convention adjourned to meet in Baltimore in June, when Douglas was nominated after a split in the convention. Subsequently the Democrats who seceded placed Breckinridge and Lane on their ticket, and thus the Democracy were irreconcilably divided.

After the adjournment of the convention at Charleston, and prior to its assembling at Baltimore, the Republicans held their nominating convention at Chicago. All the Northern States were fully represented, with partial delegations from Delaware, Maryland, Kentucky, Missouri, Virginia, with a few delegates from other Southern States. The proceedings at Charleston presaged a divided Democracy and a Republican victory. The elections of 1856 showed such Republican strength, with the accessions of four years, that the rupture at Charleston made it almost certain that the nominee at Chicago would be elected.

In their convention the Republicans confirmed the platform of 1856, and in view of recent events pronounced more decidedly against the extension of slavery in the Territories. It also advocated a tariff that would stimulate and protect home industries, and it embraced other economic questions.

The platform of 1860 contains the following resolutions or "planks":

7. That the new dogma, that the Constitution, of its own force, carries slavery into any or all of the Territories of the United States, is a dangerous political heresy, at variance with the explicit provisions of that instrument itself, with contemporaneous exposition, and with legislative and judicial precedent—in revolutionary in its tendency, and subversive of the peace and harmony of the country.

8. That the normal condition of all the territory of the United States is that of freedom; that as our republican fathers, when they had abolished slavery in all our national territory, ordained that "no person shall be deprived of life, liberty or property, without due process of law," it becomes our duty, by legislation, whenever such legislation is necessary, to maintain this provision of the Constitution against all attempts to violate it; and we deny the authority of Congress, of a territorial legislature, or of any individuals, to give legal existence to slavery in any Territory of the United States.

11. That Kansas should, of right, be immediately admitted as a State under the constitution recently formed and adopted by her people, and accepted by the House of Representatives.

12. That, while providing revenue for the support of the

general government by duties upon imports, sound policy requires such an adjustment of these imports as to encourage the development of the industrial interests of the whole country; and we commend that policy of national exchanges which secures to the working men liberal wages, to agriculture remunerative prices, to mechanics and manufacturers an adequate reward for their skill, labor, and enterprise, and to the nation commercial prosperity and independence.

The election of Abraham Lincoln was a still greater triumph, from the fact that the Republicans secured both branches of Congress, and this intensified public feeling in the South. As a final attempt to compromise in the interest of slavery, Congress on March 2, 1861, passed a joint resolution proposing an amendment to the Constitution that "No amendment shall be made to the Constitution which will give to Congress the power to abolish or interfere within any State, with the domestic institutions thereof, including that of persons held to labor or service by the laws of said State." Pres. Lincoln in his inaugural address expressed his satisfaction at such an amendment. Ohio and Maryland immediately ratified the measure, but no other States took action on it. It came too late, for secession was already sweeping over the Southern States.

Lincoln sought to calm the storm by promising protection to all the States, and by assuring the people that the security of none should be endangered, but the bombardment of Fort Sumter was the response, and its surrender in April, 1861, notified the people that rebellion and civil war had begun. On the 15th of April the President issued a call for 75,000 troops, and the controversy which legislation had failed to settle was to be decided by force of arms. Through the efforts of the anti-slavery element, compensated emancipation had removed slavery from the District of Columbia, and Pres. Lincoln in order to keep the "Border States" from joining the South proposed the same policy to them. But the practicability and even the constitutionality of the plan was questioned, and Congress took no action on the proposal.

The President's call for troops was responded to by all the Northern States, but evaded or refused by the "Border States." Some complied under certain conditions, such as for home defence. The battle of Bull Run and the defeat of the Union army in July, 1861, intensified the war feeling on both sides, and Mr. Lincoln's administration was sustained by Congress in providing for the emergency. It then authorized the enlistment of 500,000 volunteers; in July, 1862, there was a call for 300,000 and in August following a draft for 300,000 more was ordered. In June, 1863, 100,000 men were called for to resist invasion of Pennsylvania and other loyal States; in October, a call for 300,000; in February, 1864, a draft for 500,000; in March following, an additional draft for 200,000, and in April of the same year 85,000 one hundred days' men were accepted.

The Republicans were the distinctive war party, and they gave support to the demands made by Mr. Lincoln and his cabinet. Southern Senators and Representatives had left their seats in Congress and joined in the rebellion, and hence a large majority of those who remained were in harmony with the administration. As a rule, what the President asked for was granted. He desired to make the war short and decisive, and when he asked Congress for 400,000 men and \$400,000,000 it added one-fourth to each request. Thus the Republican party was as fully the war party during the rebellion as the Whigs were in the Revolutionary war, or the Democrats in the war with Mexico, and in each instance they were sustained by the majority sentiment of the country. This truth is stamped on almost every war measure, and certainly on every political measure incident to the rebellion.

The Thirty-seventh Congress is of historic note because of the era it marks, and also because it concern

trated and crystallized all that formerly was drifting or doubtful in the Republican party. The emergencies of the hour required prompt and heroic treatment, and that Congress had to grasp great and vital questions as they followed each other in rapid succession. Hence it changed the creed of many. It made the rebellious South still more vehement and determined; it separated the Southern Unionists from former friends and built a wall of fire between them. It changed the temper of Northern Abolitionists, divesting them of factious spirit and pride of methods, and compelled them to unite with the Republicans, who were making sure advances, from their original declaration that slavery should remain within present bounds, to emancipation, and finally to arming the liberated slaves. It brought many Northern Democrats into the Republican party, and reformed the political parties of the North. This may be termed the pivotal Congress, for it defined a policy for the Republican party, which, in the main, has been followed to the present day. Prominent amongst the Republicans in that Congress was Charles Sumner, of Massachusetts, scholar, orator, and statesman. Senator Fessenden, of Maine, was a recognized leader until the impeachment trial of Andrew Johnson. Thaddeus Stevens, "the Commoner," was a leader of the House, an Abolitionist in creed and a practical and brave legislator. He was a radical of the radicals, holding that the government could go outside of the Constitution to defend itself from destruction. Schuyler Colfax was one of the rising men in that Congress. He became Speaker of the next House, and subsequently Vice-President of the United States. With him in the House were Justin S. Morrill, the author of the tariff bill which raised hundreds of millions to support the army; Henry L. Dawes, the "man of statistics" and the "watch-dog of the Treasury." Roscoe Conkling was then the leader of the New York delegation; Ohio was represented by Ashley, Bingham, and Sherman. Illinois gave four prominent anti-Lecompton supporters of the administration—Douglas in the Senate, and Logan, McClernand, and Richardson in the House; while Lovejoy and Washburne were stalwart Republicans from that State. At this session Senator Lyman Trumbull reported a bill from the Judiciary Committee of which he was chairman, to confiscate all property and free all slaves used for insurrectionary purposes.

Pres. Lincoln's proposal for compensated emancipation expressed also the opinion of several leading Republicans. He sent to the Thirty-seventh Congress a special message, recommending the passage of the following resolution: "Resolved, That the United States ought to co-operate with any State which may adopt gradual abolishment of slavery, giving to such State pecuniary aid, to be used by such State in its discretion, to compensate for the inconveniences, public and private, produced by such change of system." At a conference with the Senators and Representatives of the Border slaveholding States, held at the Executive Mansion, Pres. Lincoln gave his views on the subject and in his presentation of it he said: "I do not speak of emancipation *at once*, but of a decision *at once*, to emancipate *gradually*." Two days later, July 14, 1862, a majority of the representatives of those States sent an official reply, rejecting the proposition. This closed the conference.

It was, however, evident that the institution of slavery must share the fate of those in armed rebellion, and that the Union and slavery could not both be preserved. In September, 1862, the President by his proclamation served notice on the rebel slaveholders that if they did not lay down their arms in the meantime he would on the following New Year's Day declare free all persons held as slaves in the rebellious States. As this preliminary warning produced no effect, the famous Emancipation Proclamation was issued Jan. 1, 1863, "as a fit and necessary war-measure

in suppressing said rebellion." The border States that declined the proffer of compensated emancipation were not included in the proclamation, but in the following year emancipation was made general, without compensation, and those States or portions of States lost all consideration for their slaves. In February, 1864, the Thirteenth Amendment to the Constitution was reported to the Senate, and in May it was passed by that body. In the House it was voted on in June, but did not obtain the necessary two-thirds vote and a motion to reconsider carried it to the next session of Congress.

The Republican convention met in June, 1864, and renominated Pres. Lincoln. Its platform asserted that slavery was the cause and constituted the strength of the rebellion, and, "as it must be always and everywhere hostile to the principles of Republican government, justice and the national safety demand its utter and complete extirpation from the soil of the republic." It also declared in favor of a constitutional amendment prohibiting the existence of slavery within the United States. It pronounced against any compromise with those in arms against the government, except one based on an unconditional surrender, and a return to an allegiance to the Constitution and laws.

The Democrats at their convention held Aug. 30th, when they nominated Gen. McClellan, made a direct issue on the above policy by resolving that as the war had been a failure, "justice, humanity, liberty, and the public welfare demanded that immediate efforts be made for a cessation of hostilities, with a view to an ultimate convention of the States, or other peaceable means, to the end that, at the earliest practicable moment, peace may be restored on the basis of the Federal Union of the United States."

The issue involved was for or against the amendment to the Constitution, or in reality whether slavery should be forever abolished. The Emancipation Proclamation of Pres. Lincoln brought forth these resolutions, and in his letter of acceptance he indorsed the Republican position.

In Pres. Lincoln's second inaugural address, delivered March 4, 1865, he spoke the following words, since often quoted as typical of the kindly disposition of the man believed by his party to be the greatest American since Washington: "With malice toward none, with charity for all, with firmness in the right, as God gives us to see the right, let us strive on to finish the work we are in, to bind up the nation's wounds, to care for him who shall have borne the battle, and for his widow and orphans—to do all which may achieve a just and lasting peace among ourselves and with all nations."

He could well afford to show that generosity, which never comes more properly than from the hands of the victor. His policy was about to end in a great and lasting triumph. In less than five weeks from the day when Lincoln made that utterance Gen. Lee had surrendered the main army of the Southern Confederacy to Gen. Grant at Appomattox on terms at once magnanimous and so tersely and briefly stated that they won the admiration of both armies.

Then followed a grave and responsible political work—the actual reconstruction of the States lately in rebellion. This work gave renewed freshness to the leading political issues incident to the war, and also opened out new issues. It was claimed that Pres. Lincoln had a reconstruction policy of his own because he was so anxious for the admission of Louisiana and Arkansas, but it certainly never had taken definite shape. On April 15th, six days after the surrender of Lee, the President was shot by J. Wilkes Booth at Ford's theatre. The entire nation was appalled at the deed. No man was ever more sincerely mourned by all classes. Even the Southern leaders believed this rash act had lost to them the life of one who had never been harsh, and, while firm, was always generous. The North had looked upon him as "Father

Abraham," and all who viewed the result of the murder from sectional or partisan standpoints thought his policy of keeping with the people would have protected every proper interest. No man in public life ever had less pride of opinion, and had he lived to serve out his term of office it is more than probable he would have shaped events, as he had during the war, to the best interests of the victors and without unnecessary harshness to the vanquished.

The decisive victory at the elections, giving the Republican candidate 212 out of 233 electoral votes, gave the Republicans more aggressiveness, because they had been sustained by such an overwhelming majority. The anti-slavery amendment to the Constitution, which had failed to pass the House at the previous session of Congress, received more than the necessary two-thirds vote. The elections showed the strong drift of public feeling, and the Republicans construed the result as a virtual adoption of this amendment. When it was first suggested it aroused some opposition, but the majority of the people considered the amendment a political necessity to settle forever the question that had so long disturbed the country; 27 States voted in its favor, and in December, 1865, it was proclaimed a part of the Constitution. (See RECONSTRUCTION.)

Vice-Pres. Andrew Johnson had succeeded to the Presidency, and his administration was marked by a fierce conflict between him and the party that elected him. The result was that nearly all the Republicans opposed his policy and nearly all the Democrats approved it. So radical had this difference become that he vetoed nearly all the political bills passed by the Republican Congress from 1866 until the close of his administration, but such was the Republican preponderance in both Houses of Congress that they passed them over his vetoes by the necessary two-thirds vote. He vetoed the several freedmen's bureau bills, the civil rights bill, that for the admission of Nebraska and Colorado, the bill to permit colored suffrage in the District of Columbia, one of the reconstruction bills, and finally he made a direct issue with the powers of Congress by his veto of the civil tenure bill, March 7, 1867, and his subsequent attempt to oust Secretary Stanton from the cabinet.

The political differences between Pres. Johnson and the Republicans were not softened by their attempt to impeach him, which needed only one more vote to make the necessary two-thirds. It is indeed remarkable that the failure of their efforts did not weaken the Republicans as a party. They were so well united, and so strong in that unity, that the seven Republican Senators who voted to acquit the President passed at least temporarily from public life, some of the ablest, like Senators Trumbull and Fessenden, retiring permanently. Pres. Johnson pursued his policy, save where he was prevented by Congress, until the end, and he then retired to his native State, but was subsequently elected to the Senate.

The presidential campaign of 1868 resulted in the election of Gen. U. S. Grant by a majority of 134 electoral votes, Schuyler Colfax being elected Vice-President. At the commencement of his administration the colored people had not suffrage in some of the States, and to make it universal the Fifteenth Amendment was proposed and adopted by the State Legislatures. It did not receive a Democratic vote in either branch of Congress, and it was opposed by that party in the State Legislatures. On March 30, 1870, it was proclaimed a portion of the Constitution. Pres. Grant, in a special message announcing the ratification of the amendment, declared it a "measure of grander importance than any other one act of the kind from the foundation of our free government to the present day." Thus the proclamation of Mr. Lincoln, declaring what would be done in a subsequent order, found its continuation in this amendment, making its primal object and the resultant a part of the Constitution.

Reconstruction having been completed, a new question was brought before the Forty-first Congress by Pres. Grant, which was the annexation of San Domingo. The treaty of 1869, looking to that object, was rejected by the Senate, and a dispute about its negotiation was the origin of the rupture between Pres. Grant and Senator Sumner, who had been chairman of the Senate committee on foreign affairs.

With the exception of Louisiana, Florida, and South Carolina, the Southern State governments were under Democratic control, and Pres. Grant was called on by the Republicans for military aid to prevent the disfranchisement of the negroes, but he declined to interfere except to request the U. S. attorney-general to give them legal advice.

The Fifteenth Amendment did not produce the desired results in the South, because it was evaded or resisted, and the Republicans insisted that additional legislation was necessary to enforce its provisions. On Feb. 28, 1871, such an act was passed, and a supplementary bill became a law a year later. This legislation, enacted through Republican votes, extended the powers of the Federal supervisors and marshals and gave the Federal circuit courts exclusive jurisdiction of all cases tried under the provisions of the act and its supplements. It also empowered these courts to punish any State officer who should attempt to interfere with or try such cases as in contempt of the courts' jurisdiction.

The Forty-second Congress, organized in March, 1871, was not so strongly Republican as its predecessor. The most exciting question that came before that body was the Force bill, as it was called, intended to enforce the provisions of the Fourteenth Amendment. The act allowed suit in the Federal courts against any person who should deprive another of the rights of a citizen. It also provided that inability, neglect, or refusal by any State government to suppress such conspiracies, or their refusal to call upon the President for aid, should be deemed a denial by such State of the equal protection of the laws under the Fourteenth Amendment. It further declared such conspiracies "a rebellion against the government of the United States," and authorized the President, when in his judgment the public safety required it, to suspend the privilege of *habeas corpus* in any district, and suppress any such insurrection by the army and navy.

The first regular session of this Congress began Dec. 4, 1871. The Democrats consumed much of the time in efforts to pass bills to remove the political disabilities of former Southern rebels, and they were materially aided by the editorials of Horace Greeley in the *New York Tribune*, which had long contended for universal amnesty. At this session all such efforts were defeated by the Republicans, who invariably amended such propositions by adding Sumner's supplementary civil rights bill, which was intended to prevent any discrimination against colored persons by common carriers, hotels, or other chartered or licensed servants. The Amnesty bill, however, was passed, May 22, 1872, after an agreement to exclude from its provisions all who held the higher military and civic positions under the U. S. government previous to their joining the Confederacy—in all about 350 persons. Subsequently many special acts removing the disabilities of these excepted persons were passed.

During Pres. Grant's second term civil service reform became a leading topic. March 3, 1871, an act was passed empowering the President to commence said reform, and he appointed a commission with George W. Curtis as chairman. A section in the sundry civil appropriation bill gave the President authority to prescribe the rules, and a commission was appointed by him to draft them. The committee's plan was approved by the President, and they are substantially the same as those now in force. In its exe-

cution or effect it has not met the full expectation of its advocates.

The platform adopted in June, 1872, by the Republican convention at Philadelphia, declared that the constitutional amendments should be sustained; advocated civil service reform; opposed further grants of public lands; favored the abolition of the franking privilege, and declared the necessity for shaping legislation so as to give an ample field for capital and labor. It denounced repudiation of the public debts; advocated a speedy return to specie payments; approved the amnesty acts, and favored such measures as would tend to encourage and restore American commerce and ship-building.

A sensation in political circles was excited during the presidential campaign of 1872 by the exposure of the Credit Mobilier, and at the commencement of the next session of Congress, Speaker of the House James G. Blaine asked that a committee be appointed to investigate the charges made. These charges were that Schuyler Colfax, Vice-President, and several members of Congress had been bribed in 1867 and 1868 by Oakes Ames, a member from Massachusetts, to influence their official action for the benefit of the Union Pacific Railroad Company. The committee consisted of Poland, of Vermont; McCreary, of Iowa; Banks, of Massachusetts; Niblack, of Indiana; and Merriek, of Maryland. The accusations were made by Henry S. McComb, of Wilmington, Del., and some of the most prominent members, principally Republicans, were made the subjects of the investigation. As Congress was Republican at the time, the responsibility of the legislation rested with that party, and hence it was used against it in the presidential campaign. The proceedings are too voluminous to permit of even an abstract. The committee reported in each individual case, and in effect exonerated all from criminal action with the exception of Oakes Ames, who was at the head of the Credit Mobilier, and Representative James Brooks, of New York, who was a government director of the Pacific road. They recommended the expulsion of those two members, but the House modified it to the "absolute condemnation of the House."

During the same session the President's salary was increased to \$50,000 per annum, the act to abolish the franking privilege passed, and Congress voted to increase the pay of members of both houses to \$7500 per annum, including the current year. The latter act proved so unpopular that the old salary of \$5000 was restored, and many of the members either refused to take or returned the extra compensation to the treasury.

The closing session of the Forty-third Congress marked another era in politics—a conflict of State governments. In order to secure the political rights of the colored citizens in the Southern States, the Republicans in Louisiana increased the power of its returning boards, so that they had the power to reject a portion or the whole of a district where frauds were proven. Two boards had been appointed, each claiming to be legal and this was followed by two distinct State governments in Louisiana—the McEnery, or Democratic, and the Kellogg, or Republican. The latter instituted suit against the former, and the court issued an order authorizing the Kellogg party to take possession of the State-house and oust the Democratic Legislature. Both parties demanded the recognition of the national government. Congress refused to recognize directly either governor or Legislature, and a bill was introduced declaring the elections upon which those governments were based null and void; and providing for a new election, but was defeated. In order to ascertain the actual conditions of affairs Gen. Sheridan was sent to Louisiana and in January, 1875, he made his report which startled the country. It showed a condition of anarchy, violence and murder that demanded immediate action, and March 1, 1875, the House recog-

nized the Kellogg or Republican government by a strict party vote. Four days later the Senate by a party vote confirmed the action of the House.

In order to ascertain who were entitled to seats in the State Legislature a special committee of the House was appointed, which made an award in April, 1875, known as the "Wheeler Compromise." This award was accepted until the election in 1876, when both parties claimed the election of their candidates for governor and members of the Legislature. Gen. Grant requested committees of gentlemen of both parties to witness the count of the returning board, and committees of investigation were appointed by both Houses of Congress. A series of rebellious proceedings ensued, during which the State government was practically destroyed, the Packard or Republican branch complaining of outrages by the "White League," and the Nicholls or Democratic branch denying the charges, professing to accord rights to all classes and to obey instructions from Washington until Congress or the President should decide between them. No decision was made, as Pres. Grant believed that belonged to the duties of his successor in office.

The supplementary civil rights bill, known as the Sumner bill, was passed March, 1875, after the death of its author. The first conviction under the act was in 1876, before Judge Cadwalader, of Philadelphia, when a colored resident of Virginia brought suit for being refused hotel accommodations.

The platform adopted by the Republican convention at Cincinnati in June, 1876, was mainly a reiteration of its former principles. It declared the United States a nation, not a league; advocated a rigid enforcement of the constitutional amendments, and declared it the duty of the party to compel it. It advocated civil service reform, asserted that Congress had sovereign power over the Territories, and charged the Democratic party with being the same in character and spirit as when it sympathized with treason; with making its control of the House of Representatives the triumph and opportunity of the nation's recent foes; with reasserting and applauding in the national capital the sentiments of unrepentant rebellion; with sending Union soldiers to the rear, and promoting Confederate soldiers to the front; with deliberately proposing to repudiate the plighted faith of the government; with being equally false and imbecile upon the overshadowing financial questions; with thwarting the ends of justice by its partisan mismanagement and obstruction of investigation; with proving itself through the period of its ascendancy in the lower House of Congress utterly incompetent to administer the government.

The presidential election of 1876 was particularly animated, and the excitement was intensified by the result. Both parties claimed a victory, and up to a few days before the time to inaugurate the President the excitement continued. It was claimed that Hayes and Wheeler carried all of the Northern States except Connecticut, New York, New Jersey, and Indiana, and Tilden and Hendricks all the Southern States except South Carolina, Florida, and Louisiana. Those three States were claimed by the Democrats, but South Carolina was soon conceded to the Republicans. The electoral votes of Florida as stated by the returning board belonged to the Republicans by a majority of 926, and a second count, ordered by the State Supreme Court, reduced it to 206. In Louisiana the Packard Board refused to allow any Democrats to participate and certified a majority of 3931 for the Republican electors. McEnery, who claimed to be governor, repudiated the return of the board, and gave the Democratic electors the certificate on a majority of 7876. In Oregon it was claimed that one of the Republican electors was ineligible, being a Federal office-holder, and the Democratic governor gave one Democratic elector the certificate of election, but the three Republican electors were certified by the secretary of state.

During the ensuing controversy a sensation was made by the publication of "cipher dispatches," which Mr. Pelton, the nephew and private secretary of Mr. Tilden, had sent to Democratic "visiting statesmen" in the disputed sections. In 1878 the Potter investigating committee subsequently confirmed the "cipher dispatches," but Mr. Tilden denied any knowledge of them.

The second session of the Forty-fourth Congress met on Dec. 5, 1876, and while by that time all knew the dangers of the approaching electoral count, yet neither House would consent to the revision of the joint rule regulating the count. The Republicans claimed that the President of the Senate had the sole authority to open and announce the returns in the presence of the two Houses; the Democrats disputed this right, and claimed that the joint body could control the count under the law. But the impending danger was avoided by the patriotism of prominent members of Congress representing both political parties. These gentlemen, after several private conferences, substantially agreed upon a result several days before the introduction of the Electoral Commission Act. The leaders on the part of the Republicans in these conferences were Conkling, Edmunds, Frelinghuysen; on the part of the Democrats Bayard, Gordon, Randall, and Hewitt, the latter a member of the House and Chairman of the National Democratic Committee. That the Electoral Commission was a Democratic measure is shown by the character of the votes cast for and against it. In the Senate there were 21 Republicans for it and 16 against, while there were also 26 Democrats for it to only 1 (Eaton) against. In the House nearly the same proportion was maintained, the bill passing that body by 191 to 86.

The Electoral Commission was composed of five Senators, five members of the House of Representatives, and five Associate Justices of the Supreme Court. This extra-constitutional body met Feb. 1, and by uniform votes of 8 to 7 decided all objections to the electoral votes of Florida, Louisiana, South Carolina, and Oregon in favor of the Republicans, and while the two Houses disagreed on nearly all of these points, the electoral votes were, under the provisions of the law, given to Hayes and Wheeler, and the final result declared to be 185 electors for Hayes and Wheeler to 184 for Tilden and Hendricks.

Thus closed the most important crisis that ever attended an electoral count. Had not wisdom prevailed over partisan feelings it is probable that instead of a peaceable solution disorder, riot, and bloodshed would have resulted.

The opening acts of Pres. Hayes' administration tended to alienate the stalwart wing of his party. The withdrawal of the U. S. troops from the South and the overthrow of the Packard rule in Louisiana gave his policy a tone too concessive to Southern demands. Later his efforts to prevent intimidation of negro votes in the South reunited his party. His veto of the judicial expense bill for the reason that it would prevent him from enforcing the election laws, and his special message asking that the appropriation bills be passed without the objectionable rider, brought him into full party favor. At the extra session of 1879, the main business of which was to pass the necessary appropriation bills, the Democrats continued their former tactics of adding riders to prevent U. S. supervision of the elections, but the President still interposed his vetoes. The firm attitude of the President and the party leaders on that question roused new spirit among the Republicans and did much toward giving them a majority in the House at the next election.

The most important political action taken at this session was the passage, for Congress was still Democratic, of a law to keep the peace at the polls. To this was added the Garfield proviso that it should not be construed to prevent the constitutional use of the

army to suppress domestic violence in a State—a proviso which in the view of the Republicans rid the bill of material partisan objections, and it was therefore passed and approved. The "political riders" were again added to the appropriation and deficiency bills, but were again vetoed and failed in this form to become laws. Upon these questions Pres. Hayes showed much firmness. During the session the Democratic opposition to the general election law was greatly tempered, the Supreme Court having made an important decision which upheld its constitutionality.

At the second session of the Forty-sixth Congress Pres. Hayes suggested the retirement of the legal tender notes and the maintenance of the policy for the accumulation of a sinking fund to pay the national debt. Sixteen days after Congress met gold sold at par in New York and specie payment became a fact.

The 3 per cent. funding bill was vetoed by Pres. Hayes for the reason that he and a majority of the Republicans in Congress did not believe the loan could be advantageously placed at that rate. Finally a bill fixing the rate at $3\frac{1}{2}$ per cent. became a law. Yet two years later the loan was successfully placed at 3 per cent. In reviewing the party for twenty years the convention at Chicago presented its claims for public support in the following declarations:

It suppressed a rebellion which had armed nearly a million of men to subvert the national authority. It reconstructed the union of the States with freedom, instead of slavery, as its corner-stone. It transformed four million of human beings from the likeness of things to the rank of citizens. It relieved Congress from the infamous work of hunting fugitive slaves, and charged it to see that slavery does not exist. It has raised the value of our paper currency from 38 per cent. to the par of gold. It has restored, upon a solid basis, payment in coin for all the national obligations, and has given us a currency absolutely good and equal in every part of our extended country. It has lifted the credit of the nation from the point where 6 per cent. bonds sold at 86 to that where 4 per cent. bonds are eagerly sought at a premium. Under its administration railways have increased from 31,000 miles in 1860 to more than 82,000 miles in 1879. Our foreign trade has increased from \$700,000,000 to \$1,150,000,000 in the same time, and our exports, which were \$20,000,000 less than our imports in 1860, were \$264,000,000 more than our imports in 1879.

Without resorting to loans, it has, since the war closed, defrayed the ordinary expenses of the government, besides the accruing interest on the public debt, and disbursed annually over \$30,000,000 for soldiers' pensions. It has paid \$88,000,000 of the public debt, and, by refunding the balance at lower rates, has reduced the annual interest charge from nearly \$151,000,000 to less than \$89,000,000.

The financial history of the Republican party is one of its proudest boasts. It took charge of the government in its extremity, without money or credit. It succeeded in negotiating enormous loans and in establishing a paper currency that finally assumed a gold value. It established the national banking system, which has received the commendation of all and which should be preserved as a firm foundation for the country's prosperity. The resumption of specie payments marked an important era, because it was the fulfilment of a pledge made by the party. The reduction of the public debt and the steadily reduced rate of interest show the wisdom of a policy which was adopted in the days of the nation's trial.

The administration of Pres. Hayes tended to awake a more independent sentiment in his party, and the divergence of the two wings became more apparent in the future. Impartial historians must give his administration the credit of softening party asperities and aiding very materially in the restoration of better feeling between the North and South. That his policy was the best for his party as well as his country was shown by the result of the following Presidential election.

The Republican nominating convention of 1880 was very exciting. Gen. Grant was urged by his special friends as a candidate. As the result showed, the

field was against what was called a "third term" and Gen. James A. Garfield was nominated on the thirty-sixth ballot. So intense was the feeling between the rival factions that it looked as if a divided party and defeat would follow, but the friends of Grant, as a rule, accepted the verdict of the convention, and former dissensions were put aside for present success. The Democrats made a strong nomination in the person of Gen. Winfield S. Hancock. The tariff became an important issue, the Democrats advocating "a tariff for revenue only." That plank was attacked by the Republicans, who favored a tariff for the protection of American labor. The Republicans were doubly successful, electing their President, and also a majority of the lower House, thus giving them entire control of the government.

The death of Pres. Garfield, and the induction of Chester A. Arthur to the presidential chair, caused, for the time, considerable unrest and division in the party. No person entered on presidential honors under more serious difficulties than Arthur, yet by his manly and conservative course he won the confidence of his party and the approbation of the whole people. Practically, there was no administration of Pres. Garfield, his official acts being almost entirely confined to official appointments, in which it was alleged he was unduly influenced by Mr. Blaine, his Secretary of State. His selection of William H. Robertson as collector of the port of New York estranged Senator Conkling and others, and when the nomination was confirmed by the Senate, May 17, 1881, Senators Conkling and Platt resigned their seats. This act caused a serious rupture in the party, and the effect was visible in the campaign of 1884, when Mr. Blaine lost New York, and through that loss was defeated for the presidency.

During the administration of Pres. Arthur the civil service act was passed, and the tariff reduction act of 1883; while the merchant marine act, which was passed, did much to relieve the business interests of the nation. Legislation against polygamy dated back to 1862, but it proved inoperative, and the Edmunds bill, which was signed by Pres. Arthur, was intended to effect what previous legislation had failed to do. Though the administration of Pres. Arthur had won for him public esteem, yet the popularity of James G. Blaine overshadowed that of all other competitors for the presidency in 1884. When the National Republican convention met at Chicago in June, he received the nomination on the fourth ballot. Gen. John A. Logan was nominated for Vice-President. The Democrats nominated Grover Cleveland and Thomas A. Hendricks. The issues were, in the main, a repetition of those since the war, although the tariff became a more prominent factor. The Chinese exclusion question also entered into that campaign. The Republican platform declared: "It is the first duty of a good government to protect the rights and promote the interests of its own people. The largest diversity of industry is most productive of general prosperity and of the comfort and independence of the people. We, therefore, demand that the imposition of duties on foreign imports shall be made, not for revenue only, but that in raising the requisite revenues for the government such duties shall be so levied as to afford security to our diversified industries and protection to the rights and wages of the laborer, to the end that active and intelligent labor, as well as capital, may have its just reward, and the laboring man his full share in the national prosperity." It pledged the party to correct admitted inequalities in the existing schedule of duties without injuring our industries. It advocated "retrenchment and reform," and in the contest that followed they became prominent issues. The Democrats demanded the abolition of the internal revenue as a war-tax.

The charges made by the Democrats, that a long term of service had corrupted the Republican party,

and that a change was needed, had some effect in deciding the contest. Another element in favor of the Democracy was the disaffection in New York through the opposition of ex-Senator Conkling, and the result of the election in that State showed its deciding power. That State decided the contest in favor of Cleveland by a plurality hardly exceeding 1000. Several causes may be given for the Republican defeat, but it is certain the Blaine-Conkling quarrel had sufficient effect to elect Cleveland. The vote in the electoral college stood 218 for Cleveland and 182 for Blaine. All the Southern States chose Democratic electors.

When Pres. Cleveland was inaugurated, March 4, 1885, the Republicans resigned the control of the government which they had held for twenty-four years. The history of the Republican party during Pres. Cleveland's administration mainly consists in its efforts to prevent the passage of measures antagonistic to its creed through the interposition of a Republican Senate.

The President stood pledged to enforce the civil service policy, and for a time he endeavored to keep it. But his party demanded the fruits of their victory, and the pressure became so great that he was compelled to depart from his own convictions. An outward show of observance was maintained, but the dismissal of Republican office-holders was the rule, and their retention the exception. In fact, the provisions of that law and the regulations under it have not been effectually enforced by either party. It had been predicted by politicians that its enforcement would weaken and tend to divide the party in power, and neither was willing to take the risk.

During the administration of Mr. Cleveland the House was Democratic, but the Senate remained Republican, and hence no legislation could be had without the consent of the representatives of both parties. On the important question of the tariff the "protective" character of the Senate was a bar to the House, which favored a sweeping reduction of duties. On this question the President was pronounced in favor of tariff revision. The bill, presented by Col. W. R. Morrison, known as the "horizontal bill," was opposed by the Republicans, and with the aid of some Democratic members, led by Mr. S. J. Randall, it failed to pass that body. The Republicans carried the issue into the campaign of 1886, but failed to secure a majority in the next Congress, although Col. Morrison and Mr. Hurd, two of the leaders in the tariff reform movement, were defeated.

Pres. Cleveland's message to the new Congress was confined to the same issue, recommending a revision of the tariff, and declaring the present tariff "vicious, illogical, and inequitable." It gave rise to an earnest and prolonged party contest in Congress. Mr. Roger Q. Mills, Chairman of the Ways and Means Committee, reported a bill, making radical changes in duties and placing certain articles, including lumber and wool, on the free list. The Republicans opposed it as a step towards free trade. All the Democrats in the House except a very few supported the bill as a party measure, and after a prolonged discussion it passed the House. When it came before the Senate, a committee of that body substituted another bill, protective in its character, which has not yet received final action. This contest, which resulted in a drawn battle in Congress, became the issue in the subsequent presidential campaign.

There was yet another prominent question which needs to be noted. Since the expiry of the reciprocity treaty with Canada, in 1881, there have been frequent serious disputes with regard to the rights of American fishermen in Canadian waters. To settle these troubles a treaty was negotiated at Washington in 1887, but the Senate refused to ratify it as prejudicial to American interests. The President then called for discretionary authority to retaliate on Canadians for injury inflicted on American vessels, but received no response.

The tariff message of Mr. Cleveland and the passage of the Mills bill by the Democratic House foreshadowed the issues on which the campaign of 1888 was to be fought. The Democratic convention at St. Louis, in June, indorsed that policy and renominated Mr. Cleveland. Subsequently the Republican convention met at Chicago and placed itself in pronounced opposition to the Mills bill, and in favor of continuing the present protective features of the tariff. It nominated Gen. Benjamin Harrison, of Indiana, and Levi P. Morton, of New York, for President and Vice-President. There were minor questions, but the tariff was the vital issue. The rallying cry of the Republicans was "Protection to home industry;" that of the Democrats was "Tariff reform."

The campaign was one of the most earnest ever known, especially in what were termed the doubtful States—New York, Indiana, New Jersey, and Connecticut. Of these New York was considered the pivotal State, and both parties made extraordinary efforts to secure its electoral vote. Towards the close of the campaign the injudicious conduct of Lord Sackville-West, the British Minister, in giving an inquirer advice how to vote, gave an international aspect to the contest, and quickly brought about the undiplomatic minister's dismissal.

The result of the election was a decided victory for the Republicans, who secured the votes of every Northern State except New Jersey. Gen. Harrison received 233 electoral votes and Pres. Cleveland received 168 electoral votes. The Republican party not only secured its President for the next four years, but the Congress chosen gives them a majority in the House. The Senate being also Republican, the party will on March 4, 1889, have entire control of the government. As the tariff was the issue, the result of the election gives assurance that the Republican policy of protection will be preserved as essential to the maintenance of national independence and prosperity.

(t. v. c.)

REPUDIATION. The repudiation by several of the States of the American Union of their public obligations derives interest from the anomalous position of the States. Possessing both the legal capacity and the commercial credit requisite for the purpose, they are enabled to contract debts and create obligations, and yet are not subject to the means of enforcing such engagements usually associated with the capacity of incurring obligations. If their indebtedness was merely to their own citizens the case would not differ from the ordinary one of such relations between a sovereign and subject, but the obligations issued by the States are usually largely held by the people of other States and of foreign countries. If these States were independent sovereigns they could be held to accountability upon their obligations by the powers by whose subjects such obligations might be held, but as integral parts of the nation they can only be reached by foreign powers through the national government and that practically precludes resort to either reprisals or war. As it regards obligations due by a State to the citizens of another State, Amendment XI. of the Constitution prohibiting individuals from bringing suits against States in the courts of the United States cuts off judicial remedies of that class. The absence of means of enforcement tends to give to the value of the obligations issued by the States a speculative rather than an intrinsic quality where the commercial integrity of the State has not been placed beyond question by habitual good faith towards its creditors. The circumstance just mentioned will be found to have an important bearing upon the history of repudiation in the United States.

The history of repudiation shows two distinct periods when the public obligations of several of the States have been violated. The first of these periods followed the speculative era that preceded 1836, when both public and private credit was stretched to an ex-

tent that produced with its collapse commercial disaster of a widespread character. While individual credits were at that time expanded through a variety of causes of a speculative character, the extension of public credit was mainly due to excesses in the construction of works of internal improvement projected in the interest of commercial development. The second of these periods was at the conclusion of the civil war, when the waste of war and interrupted industry had to be made good by an excessive use of State credits that speedily precipitated a crisis in public credits. The first of the periods to which reference has been made was essentially commercial in the character of its causes, while the second period was distinctly political.

In 1842 Pennsylvania failed to meet the interest on her funded debt, but finally succeeded in fulfilling her engagements. Unfortunately for her fame Rev. Sydney Smith, who was one of the sufferers for the time, thought proper to trumpet her failure to the world in an essay, which is still published without any notice of the State's subsequent amends. In 1842 Maryland also suspended payment upon a debt of \$12,000,000, contracted for internal improvements, but escaped from her situation without repudiation. Mississippi allowed obligations to be dishonored that were created in aid of a banking institution that failed, alleging as the cause of repudiation that the bonds had been negotiated for less than was permitted by law. In 1837 part of the proceeds of a loan made by Michigan was lost through the agent for its negotiation, and that State declined to recognize its obligation beyond the amount that had been realized to the State therefrom, giving rise to the serious charge that it was an attempt to hold the innocent purchasers of its bonds responsible for the conduct of the agent of the State. In 1843 Louisiana authorized debts due to a failing bank, that had operated under the patronage of the State, to be paid in depreciated State bonds at par, which, although not strictly an act of repudiation, approached it closely in principle.

The foregoing instances relate to the first of the periods already mentioned, and are to be regarded as part of a general commercial crisis in which both public and private credits suffered. (See **CRISIS, COMMERCIAL.**) During the second period the failure of public credits was on the part of most of the States that participated in the rebellion, including Virginia, North Carolina, South Carolina, Georgia, Florida, Alabama, Mississippi, Louisiana, and Arkansas. The general conditions out of which the repudiation of their public debts on the part of the States last named arose were the same substantially in all of those States. In these States the means and appliances for carrying on government and commerce were reduced almost to worthlessness. Public buildings were destroyed or out of repair, the railroads were worn out, their bridges largely gone, and were crippled for want of rolling stock. It was an urgent necessity that the industry of the States should be revived, and for that purpose that commercial intercourse should be re-established, and therefore that the existing railroads should be refitted and new roads constructed, and without aid from the public credit that restoration of production must wait an indefinite time. Until State governments were established that promised some permanency the work could not be entered upon. When these governments were put in operation they were conducted by persons unskilled in public finance or in public business of any kind, who did not represent what was left to the States of wealth and commercial credit, and were antagonized by the influence that up to that time had carried on the operations of those States and maintained their credit.

To accomplish what was actually needed by taxation in the then existing state of affairs was an impossibility, and the only recourse was to the credit of the States. It was inevitable that bonds of governments

thus circumstanced would have to be sold at ruinous rates not only for the reasons common to all the States of the Union, and for the special reasons already stated, but for the additional reason that the permanency of the then existing administration in those States was not anticipated, and should those governments come into the hands of those antagonizing them, the new rulers would not be apt to regard the honor of the States as involved in the faithful discharge of the obligations created during such transition period.

These causes operated more or less throughout all the States last named, but culminated in the State of South Carolina, where reckless legislation added to the embarrassment. Repudiation in Virginia was chiefly from the fact that West Virginia had been separated as a State without provision being made for her contribution to the payment of the debt of Virginia subsisting at the time of such separation. Virginia claimed that one-third of the debt should be paid by West Virginia as her just proportion. Virginia in 1871 funded two-thirds of her debt in bonds and issued certificates for the remaining one-third, redeemable when West Virginia should assume her part of the debt. It was provided in the funding act that coupons on the bonds should be receivable in payment of taxes. Subsequently it was enacted that only coin and currency should be received in payment of taxes, thus repudiating the obligation as to coupons forming part of the Funding Act. Again in 1880 the attempt was made in the readjustment of the debt of the State to repudiate a portion of the funded debt on the ground that it represented the capitalization of interest, which in the depressed condition of the State was claimed to be unjust.

The most general ground of repudiation throughout the repudiating States was the consequence of aid having been given to railroads with no proper return to the interests of the States. North Carolina repudiated upwards of \$12,000,000 of debt alleged to have been colusively obtained under the pretence of the building of railroads. Georgia and Florida based their action upon the decision of their courts against the validity of the bonds. Louisiana placed her action upon the ground of the unconstitutionality of certain issues. Arkansas acted upon the decision of her courts. Alabama and Mississippi repudiated large portions of their debts created in aid of railroads.

The case of South Carolina fully illustrates the general situation. The inauguration of the new State government in 1863 found an empty treasury and no available means of raising money by taxation. Finding that the bonds of the new State could not be sold except at ruinous rates, temporary loans were made upon bonds as collaterals in the expectation of funding at an early day. That expectation was never realized. The maturity of the loans finally resulted in the forfeiture of the bonds and their sale at a small per cent. upon their face value. A scheme for ascertaining the true indebtedness of the State and sealing it to 50 cents on the dollar was matured and carried out and a consolidated bond issued to replace the outstanding debt. In 1880 this scheme was revised and the original validity of the bonds that entered into the new issue was submitted to judicial inquiry and resulted in the invalidating of certain classes of bonds that had previously been validated and funded.

The cases of repudiation show three modes of accomplishing that end, namely, under the decisions of the courts of the indebted States, under the action of the Legislature, and by studiously omitting to make provision for their payment where such a provision was possible. That the decisions of the courts of a State should be accredited with authority to dissolve the obligations of such State is against the principle that no one can be regarded as a competent judge in his own case. The legislative authority of a State of the Union cannot impair its obligations, as that is dis-

tinety forbidden by the Constitution of the United States. The act of repudiation by a State of the Union is therefore one of arbitrary force and not of law, for such an act cannot take proper effect under the Constitution of the United States, but it is to be regarded as simply taking advantage of its exemption from judicial compulsion. If a State fails to meet its engagements from absolute inability, its honor is untouched, and it may be entitled to sympathy. If, on the other hand, it denies the obligation when able to perform it and does not avail itself of the opportunity it possesses of submitting the question of its indebtedness to the judiciary of the United States, its justice must necessarily be brought under criticism.

The repeal of remedies existing for the enforcement of an obligation of a State at the time its debts are contracted is an unconstitutional act that can produce no proper legal effect, and those remedies still remain in vigor, although existing under the laws of the State, and this applies equally to the privileges attached to coupons. After a State has made a composition with its creditors, and especially where that composition is in the nature of a compromise, a question is presented to which little attention has been given. It has been assumed, as in the cases of Virginia and South Carolina already mentioned, that after a compromise and funding based thereon, it was competent that a State should reopen the question of the validity of the obligation that was the subject of such compromise. This cannot be done in the case of individual transactions, and no reason has yet been pointed out why it should be available to a State.

The preservation of the honor of the States of the Union seems to require that where they have reason to doubt the validity of their obligations and are satisfied that justice will admit of the solution of that doubt, they should take measures to have the question submitted to the judiciary of the United States, the only impartial tribunals in such cases, and when their inability to meet their obligations is confessed that they should readjust them upon consultation with their creditors, which can be done without loss of dignity and with the saving of their honor.

What effect the early financial history of the country may have had upon the state of opinion that rendered repudiation possible must remain the subject of conjecture. But the disposition made of the debt contracted by the issues of paper-money for the maintenance of the Revolution that gave independence to the States is clearly distinguishable from the idea of repudiation. The issues during that war constituted the currency of the country, and thus became distributed among the people, and, as they lost their purchasing value and finally ceased to perform any useful function to trade, were subject to vicissitudes tending to make their distribution still more general. When in 1790 Congress provided for funding the domestic debt at a great reduction upon its face value, the real question presented was whether that domestic debt should be at once absorbed by taxation, or that some portion of it should be left to future adjustment. The power of taxation in the hands of Congress was unlimited, and could have been extended to absorb the entire outstanding indebtedness, and that indebtedness was distributed as broadly as it would be practicable to distribute taxation for its absorption, and hence the reduction of the nominal value of the debt was equivalent to taxation for its absorption. The reason why any portion of that debt was funded must be considered to have been to postpone the adjustment of a certain portion of it to a future day, and to afford the holders of that debt the credit of the government to a limited extent to facilitate commercial operations. In view of the fact that the holders of the debt and the persons subject to taxation to pay it were practically the same, there cannot be found in the transaction the elements of repudiation.

The Confederate currency and bonds that were left

in existence at the destruction of the power upon whose credit they were issued stand in the position of representing no existing source of obligation, and the effect of the fourteenth amendment in forbidding the payment of that debt simply placed beyond the power of the government of the United States the ability to change that status into one representing the credit of the United States.

See "State Debts and Repudiation," by Robert P. Porter, *International Review*, Vol. 9; *Tenth Census U. S.*, Vol. 7.

(A. J. W.)

REQUISITION denotes an official demand by the executive of one State upon the executive of another State for the person of an offender against the civil or the criminal law. The process is often known as interstate extradition. The U. S. Constitution provides that the governor of any State shall, upon the demand of any other governor, deliver to him any person charged with treason, felony, or other crime, who has fled from justice and is found in that State. The statute of 1793 requires such demand to be accompanied by proper affidavits of the indictment, or a warrant charging him with violation of law. The construction of this statute was, for many years, exceedingly loose, because of doubt concerning the definition of "other crime." Just before the civil war of 1861 the U. S. Supreme Court, in the case of *Kentucky vs. Dennison* (24 Howard, 66), declared that any act made a crime by the laws of the demanding State was extraditable. This decision was brought about by the refusals of Northern governors to surrender parties who were charged with assisting in the escape of slaves. At present there is no uniformity in State laws regulating the return of persons charged with crime to the State in which the crime was committed, and from which they have fled. In Pennsylvania, for a number of years, the executive has followed the rule that in cases of obtaining money by false pretence, or of embezzlement, where the executive was of the opinion that the process was to be used chiefly for the purpose of collecting a private debt, a requisition would be declined. Yet requisitions continually come to the executive of that State asking for the surrender of persons charged with offences for which he would not grant requisitions. Even if criminals do not actually escape capture, States are often put to great expense and trouble for the want of uniformity in the laws; and the enforcement of justice is greatly retarded, if not altogether defeated. The Legislature of New York passed an act in 1886 which provides that no fugitive shall be taken out of the State, either with or without his consent, without a requisition being first obtained, thus preventing kidnapping and the self-surrender of persons by reason of intimidation.

In 1887 representatives of nearly all the States of the Union met in the city of New York to promote greater uniformity in methods of interstate extradition. A committee was appointed to draft a bill embodying the conclusions of the conference, and such other provisions as upon careful examination they might deem necessary to make uniform the law and modes of procedure for the extradition of fugitives from justice. The committee met in New York city, in September, 1887, and agreed upon a bill to be submitted to Congress. In substance the bill provided that a person arrested in a State other than that in which the alleged crime was committed may be bailed during extradition proceedings, but must present himself within 20 or 30 days for extradition. At the end of that time he shall be discharged if the agent of the State in which the crime was committed be not ready to receive him. Should the accused be not able to furnish bail he shall be discharged after 30 days' imprisonment if the agent is not ready. The agent must have written authority from the governor of the State surrendering the accused. Any official using violence, threats, or undue influence to compel an

alleged fugitive to leave the State to which he had removed himself shall be guilty of a felony, punishable with from 5 to 10 years' imprisonment at hard labor. The prisoner shall not be arrested upon civil or criminal process in the demanding State until a reasonable time after the proceedings for which extradition was made, so that he may have an opportunity to return to the State in which he was taken. Should a demanding governor become satisfied that the extradition proceedings have been invoked for private purposes, he may revoke the same and discharge the fugitive. The bill awaits the action of Congress.

(F. G. M.)

RESURRECTION. This term denotes the revival of the human body from the grave and its resumption of existence in a future state. It differs from immortality, which denotes merely the continued life of the soul after it has parted from its earthly tenement, and also from metempsychosis, that is, the passing of the soul of a man after death into the body of a lower animal or through a succession of such animals. It is presented in the Scriptures, not as a philosophical speculation, or a beautiful, inspiring vision, but as a constituent and necessary element in the future life of the people of God. This article will seek to give simply an outline of the way in which the doctrine has been and is considered and treated in the Christian Church; for the conception is one that has not been found with any clearness or positiveness in any of the ethnic faiths.

Scattered intimations of the truth are given in the Old Testament, as in the translation of Enoch and Elijah, in certain expressions of the Psalms (xvi. 9, lxxiii. 24-26), in the striking imagery of Isaiah (xxvi. 19), and in Ezekiel's vision (xxxvii. 1-13) of the re-animation of the dry bones. In Daniel, the last of the greater prophets, it is expressly said that "many that sleep in the dust of the earth shall awake." In the later Judaism the doctrine became clearly defined, and was held by the great body of the people, as appears from Martha's answer to Christ's promise that her brother should rise again, "I know that he shall rise again in the resurrection at the last day." The only exception to this view was the sect of the Sadducees, which, however, was neither large nor influential. In the New Testament the point is everywhere assumed or expressly asserted, our Lord calling himself "the resurrection and the life," and affirming that the rising again of the dead shall be universal, including the evil and the good. His apostles reaffirm this teaching, dwelling however with special emphasis upon the resurrection of believers, which they connect with that of Christ as its evidence and earnest and pattern. The apostle Paul, in what is the classic passage of the New Testament upon the subject, gives some animating particulars concerning the future body of the righteous, but concerning that of the ungodly neither he nor any other inspired writer says anything beyond the mere fact that they also shall rise. In the Epistle to the Hebrews the resurrection is spoken of as one of the elementary truths of Christianity, which it is, being bound up with the future life and the whole purpose of God respecting his redeemed people. Hence its general and constant reception among Christians. It is a distinct article in the Apostles' Creed, the earliest symbol of faith, and is found in every other confession of the historic church; and at this day all divisions of Christendom, however differing on other points, are at one as to the final victory over the grave at the last day.

But while there is a general agreement as to the article, "the resurrection of the dead," there is much difference as to what it implies. There are some who make it altogether figurative, as if it meant only a spiritual resurrection. Others have supposed it to mean the literal reassembling of all the particles that have at any one time been in the physical frame. Others again say that it is the continued preservation

of a small portion of these particles, which by divine power is reconstructed into a body adapted to the soul's new condition. A fourth view limits this preservation to what is called a "vital germ," which, small as it may be, suffices as a link of connection between the old body and the new. A fifth opinion is that at or soon after the moment of death there is disengaged from the mortal remains a spiritual body which, in union with the soul, passes into another state of existence. A sixth view is that the vital principle which now appropriates earthly materials will still continue to exist and will at the resurrection perform the same office as before, only upon materials of a higher class. But all these statements are merely theoretical, for the Scripture, while it often sets forth the fact of the resurrection, says nothing of the manner in which it is brought about. The only prolonged discussion, that contained in First Corinthians (chap. xv.), states results, not processes. It clearly teaches that there is not the substitution of a new body, but the transformation of the old, and the effects of this change are set forth with grace and force. "Flesh and blood cannot inherit the kingdom of God;" that is, our bodies as now organized are not suited to the new and exalted state of being. They will therefore undergo the needed change in several particulars. The body now is subject to decay and indeed is in a state of corruption, but hereafter it is to be incapable of decay or dissolution. It is now a body of humiliation (Phil. iii. 21), bearing the scars of sin and shame, but when raised it is to be fashioned anew after the pattern of Christ's glorified body as he sits at God's right hand. It is now weak and subject to many trying limitations, but in the next world it will be instinct with undecaying energy and endowed with faculties far beyond what we now conceive. It is now a "natural body," that is, one adapted to the present condition of the soul and the constitution of this world; but it is to become "a spiritual body," that is, one adapted to the glorified condition of the soul and to the constitution of the new heavens and new earth. The apostle concludes his discussion in a lofty strain of eloquence showing that in his view the resurrection of the righteous is not only of great significance in and for itself, but is also the final conquest of the redeemed over every form of evil. Still there is no answer to the many questions that arise as to the way in which this result is brought about. There always has been, and doubtless always will be, much speculation on the interesting subject, but it is foredoomed to failure. We neither know nor can know how the dead are raised up, any more than we know how the grass grows or how God exists. All that the Scripture is responsible for is the fact, and it is a very important one. Man here consists of soul and body, and hereafter he will consist of the same. The complete personality is to stand before the judgment-seat and to receive its mending retributions. To make this possible it is ordained that the dead shall be raised. The whole historical person that lived on earth is to live hereafter and to receive the just reward of his works. It is this fact which takes the tenet out of the domain of mere sentiment and gives it a place among the most important factors of human thought. It does away at once and forever with the undue disparagement of the body which has appeared at times in the Christian church, arising from the old heathen notion that matter is essentially vile, and hence that the body is the source of all sin and misery to the soul, or from certain ascetic principles which, regarding the body as an incubus or a burden, aimed not at controlling but at extirpating all natural appetites and passions. So far from this being the case, the body is an integral and essential constituent of man's nature, and as such is to be neither abused nor punished, but fostered and cared for, since even in a far higher state of being it will still hold its place in the human economy and be a fit temple of the Holy Ghost.

The objections which are made to this doctrine are

founded upon a misconception of its nature and grounds. It has been said that it is opposed to all the conclusions of physical science: for, so far as the most exact observation shows, the human body is when dead subject to the same laws of decomposition and dispersion as those which prevail over the remains of the irrational animals. In no case has there ever been seen the least sign of a tendency to resurrection any more than in the abandoned carcasses of the brute creation. To all appearance the bodies of rational and irrational beings pass away alike, and are equally and irrevocably mingled with their kindred dust. Science therefore, it is claimed, pronounces decidedly against the possibility of a resurrection. But this conclusion is much wider than the premises. Chemistry and physics can tell us what is, but not what may be. The doctrine is not a deduction from observation and experiment, nor does any one seek to establish it by the evidence of natural law. It rests wholly upon divine revelation. Whether it is within the power of God to reconstruct the decomposed body is not a matter of doubt to any intelligent theist. The same hand that made the human frame can surely restore it from any degree of decay and decomposition. The question is not one of physical inquiry or scientific analysis, but simply of revelation. Has God said that this extraordinary event shall occur? If he has, the case is closed, for of the future we certainly know only what he has declared; and that the Scripture declares that this mortal shall put on immortality is beyond doubt. The statement lies on the face of the record, and is confirmed by the consentient faith of the church from the beginning. It is identified with the integrity of the gospel and the hope of every believer, living or dying.

A much more serious difficulty turns upon the question of identity. The whole value of the doctrine as it is stated in the creeds, and as it is held in consciousness, rests upon the view that the same body that is committed to the grave rises again, so that there is a real continuity of existence. What is said is not that God will create a new body, but that he will restore the old one. But it is asked how that can be when the buried physical frame is not simply reduced to dust, but resolved into elementary principles which become so thoroughly mixed and confounded with others of the same or of a different kind, that it is quite inconceivable that they should be traced out, and separated and recombined into their old connections. To this it might be said in answer that all things are possible with God, not even this stretch of power being beyond the resources of the Infinite Mind; but a better answer is that the objection presupposes what is not the case, viz., that the doctrine implies the raising again of the same elementary particles as composed the former body. The slightest reflection shows that this is not the case. These elementary particles never have been the same during the existence of the body on the earth, but have always been in an unceasing flux. Every few years or, as some say, every year the old materials pass away and new ones take their place; indeed, so continuous is the process that no man's body one day is precisely identical with what it was the day before, or what it will be the day after. Still to all intents and purposes it is the same body, occupies the same place, and performs the same functions: the man himself feels it to be such and would be greatly surprised were any one to tell him to the contrary. Hence it is clear that the resurrection body by no means requires to be composed of the identical substance that was committed to the grave.

The same consideration disposes of the difficulty raised by some when they ask if all the defects and infirmities of the corporal frame are to be reproduced in the future life. Is the infant to be raised up as an infant; the aged man as wrinkled and tottering; the lame as still a cripple; the leper covered with sores; the deaf, or dumb, or blind, as still laboring under

these misfortunes? The question hardly deserves an answer. Experience in the present world makes it plain that all such things are mere accidents, in no case and in no degree affecting the substance of things. The human body may undergo the most serious changes either for the better or the worse without at all affecting the conscious identity of the person. And it is fair to conclude that the same fact will hold good in the future life. The body, the apostle says, is to be raised in glory, which must at least mean that whatever in the way of defect or deformity would tend to unfit it for the activities and enjoyments of the heavenly state will be left behind, and all its organs and members be exalted to the highest pitch of excellence. Yet the difference, great as it may be between the old and the new, the earthly and the heavenly, the natural and the spiritual, will not at all affect the fact that it is the same body and belongs to the same person, any more than the difference between the small acorn that is planted and the stately and widespreading oak into which it grows interferes with the identity of their existence.

The embarrassment which many feel on this point arises from confusion of thought. They assume that the same law holds in regard to living organized beings and to inanimate substances. The identity of a stone lies in the identity of the particles of which it is composed. Take away any considerable portion of those particles or substitute others in their place, and it is no longer the same stone in any proper sense. But this is not the case with a plant or a human body, as all observation shows. In them we neither seek nor find any numerical sameness of the constituent atoms. These may differ from time to time in number, in condition, in quality, but they agree in their mutual relations, and in their association with one central, formative principle. This constitutes the special individuality of any particular plant or animal. And no one has any doubt of its identity in any or all stages of its existence. The same consideration applies to the resurrection body. Of whatever sort its constituent particles may be, or whencesoever they are derived, they stand in intimate vital union with the same formative principle, and so constitute one and the same individual being. The new body thus constructed is a fac-simile of the old one. It has the same characteristic expression. It is recognized by its possessor, and it is capable of recognition by all who knew him on the earth. Every man has his personal character—peculiarities of mind and heart which distinguish him from every other man, and this character is more or less clearly revealed by the form, the features, the air, the carriage of his body. There seems no reason to doubt that this will continue in the life to come, and that the revelation of the outward by the inward will be more exact and informing in heaven than it has been or can be here on earth. It was a sight of surpassing splendor that John saw in Patmos when the glorified Saviour stood before him with a face shining like the sun, eyes like a flame of fire, and feet like unto brass burning in a furnace, but still the apostle recognized the form as that of the Son of man. Although thus transfigured, it was still the same Jesus who was born at Bethlehem and died on Calvary. Herein the Master is the pattern of the disciple, for it is written that he "shall fashion anew the body of our humiliation that it may be conformed to the body of his glory." "As we have borne the image of the earthy we shall also bear the image of the heavenly."

The sum of what has been said may be stated in the following particulars :

1. The resurrection of the dead is a doctrine of revelation, and as such is neither affirmed nor denied by physical science. 2. Properly understood it involves nothing that is unreasonable or fanciful. 3. It is of very great moment in connection with the remedial system. 4. It means that redemption is not merely pardon, or deliverance from spiritual suffering, but

takes in the whole man, the body as well as the soul. 5. It is a constituent part of the great consummation when Christ comes to wind up the present system of things. 6. It meets a deep-seated longing of our nature. 7. It does justice to the dual constitution of man as composed of both material and immaterial elements. 8. It lays a basis for the future recognition of those whom we have known and loved in the present life. 9. To the bereaved it dissipates the dark shadows that hang over the grave. 10. It makes more lively and satisfying the conceptions we are authorized to cherish concerning the eternal blessedness of the redeemed.

The literature of the subject will be found in the Appendix to W. R. Alger's *Doctrine of the Future Life*, by the late Ezra Abbot. This bibliography, which has also been issued separately, is wonderfully copious and accurate, and leaves nothing to desire. (T. W. C.)

RESURRECTION PLANT. This name is given to certain plants possessed of peculiar habits which seem equivalent to a return from death to life. The principal of these is *Anastatica Hierochuntina*, called fancifully the Rose of Jericho, a plant of the mustard family which is found in Northern Africa, Syria, and Arabia. It is an annual, with very short stems and branches radiating from its summit to the length of several inches. In the period of dry weather which follows the flowering season the branches curl inward, till the plant looks like a curious ball of wicker work, at the top of the short stem. The root now decays, and the plant, torn up by the winds, is carried long distances over the level country. If it reaches water, or is lodged where rains can fall upon it, the moistured branches unfold and expand, and the pods open and disperse their seeds, the whole arrangement being one of nature's methods for the wide dispersion of seeds. The phenomena of curling and uncurling may be indefinitely repeated by successively drying and moisturing the plant: hence its common name.

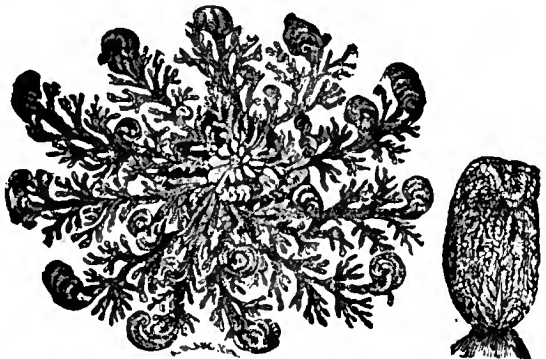

Resurrection Plant, Open.

Closed.

Another plant of similar property is the *Selaginella lepidophylla*, a cryptogamous plant allied to the *Lycopodiums*, or club mosses. It is found in the arid districts of Southern California and New Mexico, and consists of a tuft of flattened branching stems, of fern-like aspect, which are found clinging to rock crevices, the stems curled into a nest-like ball. In the rainy season they uncurl, and the plants appear as beautiful rosettes of brilliant green. When quite dead they will still expand if moistened, and they are frequently sold under the name of resurrection plant. (C. M.)

RETZSCH, MORITZ (1779-1857), a German artist, was born at Dresden, Dec. 9, 1779. He studied art at the academy there, and devoted himself to painting mythological subjects and illustrating the works of the great poets. His outline etchings of Goethe appeared first in 1812 and an enlarged edition in 1834. In 1816 he became a member of the Dresden Academy, and in 1824 he was made professor there. In 1822 he commenced a series of illustrations of Schiller's

works, in 1827 of Shakespeare, and later of Bürger's Ballads and other works. His illustrations attained popularity in England and France as well as in Germany. He died at Dresden, June 11, 1857.

REULEAUX, FRANZ, a German technologist, was born at Eschweiler near Aix-la-Chapelle, Sept. 30, 1829. At the Polytechnic School of Carlsruhe he studied machine construction, but he also studied philosophy at Berlin and Bonn. After some service as a practical engineer he became in 1856 professor of machine construction at Zurich. In 1864 he was called to a similar position at Berlin. In 1867 he served on the jury of award at the Paris Exposition, in 1873 at Vienna, and in 1876 at Philadelphia. His *Letters from Philadelphia* (1877) created a sensation in Germany by their severe criticism of the German manufactures displayed, and eventually brought about great improvement in German workmanship. Reuleaux attended the exhibitions in Sydney and Melbourne in 1879 and 1881. He has also been connected with the Imperial Patent Office. He has published *Konstrukteur* (1871), *Theoretische Kinematik* (1875), and *Quer durch Indien* (1884).

REUSS, EDOUARD GUILLAUME EUGENE, a French theologian, was born at Strasburg, July 18, 1804. He was educated in his native city and studied theology at Göttingen and Halle, and Oriental languages at Paris. He began to teach Biblical and Oriental literature at Strasburg in 1829, and became professor there in 1836. He published *Histoire de la Théologie chrétienne au siècle apostolique* (2 vols., 1852); *Histoire du Canon des Saintes Écritures dans l'Église chrétienne* (1863); *Geschichte der heiligen Schriften des Alten Testaments* (1881); *Les Épîtres Pauliniennes* (1883). He also projected a new French translation of the Bible, with introduction and notes, which was completed in 17 volumes (1874-79). Reuss was instrumental in introducing German criticism and methods of investigation among French theologians. He has taken part in editing a new edition of Calvin's *Works*.

REUTER, PAUL JULES, BARON, telegraphist, was born at Cassel, July 21, 1821. While employed as a banker's clerk at Göttingen he became interested in the discoveries in electro-magnetism. The European revolutions of 1848 suggested to him the importance of rapid communication of news. In 1849 he attempted to start in Paris a system using lithographic copies of condensations of daily news. But when the Prussian government allowed the public use of the telegraph from Berlin to Aix-la-Chapelle, he removed to the latter and sent the news thence to Brussels by means of carrier pigeons. As fast as telegraphic lines were extended, he took advantage of them, and supplied the deficiencies by couriers, steamboats, and other means, even building telegraph lines himself when permission could be obtained. In 1851 he removed his chief agency to London, whence he had communication with all parts of the world. He was naturalized as a British subject and formed a partnership with Baron Erlanger. He established close relations with the newspapers, and the *Times* called in his aid during the war in Italy in 1859. His title of baron was conferred by the duke of Saxe-Coburg-Gotha in 1871.

REVELATION, BOOK OF. This See Vol. XX. book of the New Testament is closely p. 496 (p. 510 related in thought, and to some extent Am. Rep.) in form, with the discourse about "the last things," recorded in Matt. xxiv.; Mark xiii.; Luke xxi. While it bears some resemblance to the Jewish "Apocalyptic Literature," it is as markedly distinct from writings of that class as are the Canonical Gospels from the Apocryphal Gospels. The difficulty of interpreting the book arises in part from its unique character, and from the avowedly prophetic nature of its contents. Dr. Harnack, in the article in the *ENCYCLOPÆDIA BRITANNICA*, speaks of it as "the most intelligible book in the New Testa-

ment," but the intelligibility he claims for it is dearly purchased. It will be impossible to discuss his views in detail, but the critical method of investigation he adopts has no right to call itself "historical," since it gives little or no weight to historical testimony, and deals in the most arbitrary fashion with the internal evidence furnished by the Apocalypse itself. As a result the greatest uncertainty is thrown about the question of authorship, the one question that is most readily answered; while the really difficult questions of interpretation are regarded as easy of explanation.

1. *The Author of the Apocalypse.*—External evidence points to the apostle John as the author; the witnesses on the other side usually show some prejudice against the book itself, and hence seek to deny its apostolic authority. That some other John was the author seems impossible, and the supposition "that the name of John was interpolated in the last revision (after the death of the apostle John)" is without any support, external or internal. This view scarcely differs from that which deems the book a forgery.

The objections urged by Harnack against the view that the apostle John was the author are not convincing. (1) The opinion of the so-called "Alogi" cannot outweigh the positive testimony supporting the genuineness of the Apocalypse. (2) The internal reasons are invalid; the apostle in describing his visions need not designate himself as a personal disciple; his language about the twelve apostles agrees with the character of the Apocalypse; his descriptions of Christ need occasion no difficulty. The psychological unintelligibility, alleged in the article in the *BRITANNICA*, is based upon prejudice in regard to the theological position of the assumed author. The main difficulty is based upon the obvious difference of style between the Apocalypse and the Fourth Gospel. The Tübingen school accept the former as the work of the apostle John, in order to deny the genuineness of the latter. Some critics who regard the apostle as the author of both works, accept an early date for the Apocalypse, in order to account for these differences by the long interval. But this is not necessary; the two books are totally distinct in character; one a simple historical narrative, the other a description of visions, alleged by the author to be supernatural. This of itself would account for the difference in style. The variations in language have been overestimated; the doctrinal positions are not diverse; there are, indeed, positive evidences of a common authorship, in plan, and thought, and phrase. The difficulty of forming a consistent theory other than the so-called "traditional" one will appear from the variety of opinions proposed by recent critics; most of them purely conjectural, or at best based upon assumptions respecting the origin of the New Testament books. In the case of both books the burden of proof rests with the opponents of the "traditional" view. If an early date be assigned to the Apocalypse the name of John could scarcely be interpolated, and apostolic authority so universally admitted. A later date to the Gospel calls for an author worthy of the book, and the second century does not reveal any one who could have written that Gospel. If both were written in the first century, we may most consistently accept the apostle John as the author of both.

2. *The Date of Writing.*—Recent scholarship accepts a date shortly before A. D. 70. The grounds for the opinion are (1) that the book implies that the destruction of Jerusalem had not yet occurred; (2) that the Antichrist is Nero, the number of the beast (666, chap. xiii. 18) indicating "Emperor Neron"; (3) that the earlier date allows sufficient time for the change of style noticeable in the Apocalypse and the Fourth Gospel. The last argument is of course rejected by those who deny the genuineness of either of these books. Yet the external evidence supporting the later date (under Domitian, between

A. D. 93-96) is so strong that Harnack is compelled to resort to the theory of a later revision. But these arguments are open to objections: (1) The reference to Jerusalem must be explained in a literal sense, if it points to the city as still standing, yet the rest of the book can scarcely be interpreted in this way. Moreover, it is difficult to account for the absence of specific reference to the impending destruction of that city in a professedly prophetic book, if that book were written before the catastrophe, which Christ himself had plainly predicted. (2) The interpretation of xiii. 13, as referring to Nero, as well as the assumed reference to the reigning emperor in xvii. 7-12, cannot be deemed conclusive. It is not agreed who this emperor was; it is implied that the ideal date of the vision and the actual date of the book coincide, an utterly unwarranted assumption. Furthermore, the notion that the Antichrist of the Apocalypse is Nero come to life is often linked with this argument. That notion belittles the book and virtually makes the author a superstitious dreamer, a retailer of heathen fables. Yet many interpreters who reject all this hold that the early date is to be preferred as affording a better theory of interpretation, namely, one that finds the visions, in part at least, fulfilled in the first century. (3) The difference in style between the Apocalypse and the Fourth Gospel can be explained by the difference of the character of the works. The style of the Apocalypse is not that of one unfamiliar with Greek, but rather of one choosing intelligently the peculiarities of language that he employs. As the current of opinion now sets strongly in favor of the earlier date, it is well to note some positive reasons in favor of the "traditional" view. The letters to the seven churches of Asia indicate an intimate relation with those churches. These churches were mainly founded by Paul, and up to A. D. 63 there is no hint of the presence of the apostle John in that region. He seems to have gone there to escape the impending calamities in Judea. Some time would be required for the establishment of the relations indicated by the epistles in the Apocalypse. Moreover, these seven churches are taken as representing the whole church; a fact that seems inconsistent with the earlier date, before Jerusalem had fallen. Other considerations from internal grounds tend to confirm the well-attested date in the reign of Domitian.

3. *The Canonicity of the Apocalypse.*—The book seems to have been well-nigh universally accepted in the second century. The extravagances of some interpreters led to some doubts respecting its authority, which find expression in Eusebius and other writers. But Eusebius himself did not reject it. In the fourth century these doubts were dispelled, and since that time the book has been recognized well-nigh universally, though for a long time ignored in the Eastern church.

4. *Design and Contents of the Apocalypse.*—We may dismiss at once the notion that the book is a Jewish-Christian polemic against Paul and the whole Tübingen theory respecting it. Accepting the apostle John as the author and the record of the vision as a transcript of what he actually saw "in the Spirit," we must reject all theories of its design that cast doubt upon the prophetic character it claims for itself. The article in the *BRITANNICA* assumes, as do many critics of this generation, that the author's view was "entirely bounded by his own subjectivity and circumstances" (Alford). Hence the arguments in regard to authorship and interpretation are based upon the assumed standpoint of the author, his personal hopes and fervid fancies. Its value is made to consist in the clear view it presents of the aspirations and anticipations of this unknown author, who though a Jew had a firm faith in Christ, and yet had not attained to the full freedom of the gospel. Those who accept the gospel narratives as historical will find no difficulty in believing that such visions could be made

the channel of prophetic revelation to the last surviving apostle. Those who believe in the Christ of the Gospels will find it difficult to believe that this apostle invented this Apocalyptic scenery to give expression to his own personal hopes. Regarding it as a prophecy, which it claims to be (i. 1, 2), we need not, however, regard it as a prediction of chronological details. It certainly sets forth in outline a conflict between Christ (and his people) and the enemy, but the constant recurrence of the number seven (the number of perfection) seems to indicate that this conflict extends over the entire period of the church militant, whether the various details are given in chronological sequence or not. (See further under 5.) It is therefore a book for all ages, but especially full of hope for the persecuted church.

The plan of the Apocalypse is not distinctly marked throughout, but some of the divisions are very obvious. The number *seven* is conspicuous; hence the effort has been made to find seven distinct visions, each seven-fold in its details. But it is difficult to verify this theory of the arrangement. After a prologue (i. 1-8) we find seven epistles (i. 9-iii. 22); then comes the prophetic portion, as it is termed. Here a series of seven visions may be accepted, but there are episodes, and the events signified in one vision seem to be symbolized in a succeeding one. (1) The prelude or opening vision in heaven, iv.-v. (2) The seven seals, vi.-viii. 1. (3) The seven trumpets of judgment, viii. 2-xi. 19. (4) The seven mystic figures (the woman, her enemies, the Lamb, the three angels of judgment), xii. 1-xiv. 20. (5) The seven bowls of wrath, xv. 1-xvi. 20. (6) The seven-fold judgment upon Babylon, xvii. 1-xix. 20. (7) The final triumph, xix. 11-xxii. 5. An epilogue follows in xxii. 6-21.

Some take the epistolary portion as the first in the series of seven visions, and join (1) and (2), while other variations are advocated by other interpreters. It should be noted that the numbers four, three, and twelve are also used with symbolical significance. The many correspondences between the sets of seven symbols have suggested the view that the visions, some of them at least, represent the same periods, are synchronous, not successive, in their significance; each series being complete in itself, and probably representing some aspect of the conflict, from the beginning to the close. There is, moreover, in each principal group of symbols a climax represented. All the imagery is presented with more or less of the characteristics of Hebrew poetry, parallelism, and contrast, involving occasionally double representations of the same theory, the ideal and the actual aspect of the object being described in close connection. The episodes which occur are quite obvious, and the writer frequently uses "prolepsis," anticipating "in earlier sections, by mere allusion, what he is only to explain at a later point of his revelation" (Milligan).

5. *The Interpretation of the Apocalypse.*—Three leading systems of interpretation have been advocated; a fourth is now becoming prominent. (1) The *præterist* system, or theory, applies the revelation as a whole to the early Christian ages, either to the destruction of Jerusalem or to the overthrow of heathen Rome, or to both. This system has had many advocates in the past, who accepted the Apocalypse as a real prophecy. At present it is the favorite system in Germany, but is very often joined with the "Nero fable." The earlier date of composition is usually maintained by the advocates of this system, in order to antedate the events to which the visions are assumed to refer. Undoubtedly there is an element of truth in this system, since the book itself claims to reveal "the things which must shortly come to pass" (i. 1). But to limit the meaning to events in the early centuries seems unwarrantable. For (a) the visions most obviously cover events that can become actual only at the end of time; (b) the interpretation of the special

points by this system has not been satisfactory; (c) this limited view detracts from the permanent value of the book, and often leads to a denial of its prophetic character. The strongest argument from a single detail is that based upon the number 666. It is held that this must signify the name "Emperor Nero." But this is by no means certain. The interpretation is a recent one; a dozen others have been advocated with as great plausibility. (See Schaff, *History of the Christian Church*, Vol. I., pp. 841-852, for a full statement of the various explanations.) Against this explanation of the number many objections are properly urged, drawn from the other details with which the number is connected, most of these being inapplicable to Nero. (2) The *futurist* system explains the book as referring for the most part to events still future, closely connected with the Second Advent. The element of truth here is obvious: the closing visions, probably the close of each vision, point to the end of this dispensation; but this does not warrant the limited view peculiar to this system. (a) A number of expressions in the book itself affirm that some of the events symbolized were near in time. (b) This system leads to an excessive literalism in interpreting the numbers, etc. (c) By removing the prophecies entirely out of history, it encourages fantastic chiliastic views. This school of interpreters is not numerous at present, though it still has able representatives. (3) The *historical* (or *continuous*) system extends the fulfilment of the prophecy from the First to the Second Advent, accepting a chronological sequence in the visions, either as one series, or as repeated and synchronous representations of different phases of the same great conflict. This system was advocated in the twelfth century, and since the Reformation has been the view most commonly held by Protestant scholars, before the "præterist" reaction in Germany. The Reformers were wont to identify "Babylon" with Papal Rome, and thus a dogmatic support was given to the system. That it contains more elements of truth than either of the others is quite probable. The conflict portrayed in the Apocalypse does cover the whole Christian dispensation; its leading features seem to stand out prominently, and final victory is certainly assured. But this method of interpretation, when it is applied to chronological details, involves serious difficulties, and has been used in a way alike absurd and fanatical. Nor has there been any general agreement as to the detailed interpretation. It is still disputed, for example, whether the several sets of symbols represent successive or synchronous series of events; whether the millennium has already begun or is still future; when the millennium began, on the theory that it is not still future. In fact each generation of historical interpreters is forced to reconstruct the theory of fulfilled prophecy. Contemporary events are magnified, and the attempt made to find allusions to them in the Apocalypse—the progress of history proving the special interpretation to be false. This is the story of the centuries during which this system has been the dominant one. That it has fostered fanaticism is obvious enough. We may therefore expect to find serious objections to it, in so far as it attempts to construct a chronological sequence of fulfilment answering to the visions in detail. These objections are: (a) The character of the book and its symbolical language point to an ideal rather than a historical arrangement. (b) The purpose of such a book can scarcely be to enable us to forecast the future with chronological accuracy; yet this is precisely what this school of interpreters are wont to attempt. Our Lord himself, in the eschatological discourse with which the Apocalypse is related, forbids our calculations by denying the possibility of knowing the time of that event, about which these calculations are most busy, his future Advent. (c) This theory seems to separate the book from the time in which it was written, and to deprive it of any great

practical value for the succeeding ages, a time of complete fulfilment approaches. (d) In addition to the want of harmony among the interpreters of this school we must notice the erroneous exegesis commonly employed in advocating the various theories; historical events are selected to suit the theory; some very puerile selections are to be noticed in nearly every scheme; the meaning of the symbols, the meaning of the Greek words, even the questions of textual criticism, are dealt with in a way that is utterly unjustifiable on the principles of scholarly exegesis. But the effort to discover fulfilment of prophecy has such a fascination that this system of interpretation includes among its advocates not only the ignorant mystics, but some of the most illustrious and devout exegetes of recent centuries. There can be no doubt, however, that in modern times the general effect of the elaborate schemes of historical interpretation has been to weaken the authority of the Apocalypse. The book itself has suffered from the mistakes of its would-be interpreters, who make "John a pedant, puzzling his readers with his superior knowledge of petty details, instead of a comforter, consoling and strengthening their hearts by revelation of the true relations and final outcome of things." (Warfield.) (4) The *ethical and spiritual* system of interpretation had its advocates in Alexandria in the early Christian centuries. At present it finds able supporters. The general principles on which this method proceeds are: (a) The Apocalypse covers the whole period from the First to the Second Advent, but is not designed to indicate the length of that period, nor the historical sequence of events. Time is not reckoned, though the beginning and the end, the conflict and its issue, are distinctly indicated. (b) The Apocalypse sets forth "the action of great principles and not special incidents" (Milligan). This gives to it a permanent value for all ages. (c) The figures of the book, material and local, are to be interpreted in a spiritual and universal sense. The visions are therefore regarded as synchronous, not successive. The three main principles set forth in the Apocalypse are: the conflict of Christ's people, the preservation of that people, and the ultimate triumph. Not only conflict but apostasy and degeneracy are predicted, and also final victory. This view does not accept a chronological explanation of the "millennium." The spiritual lessons of the book, on this view of it, are marked, and pertinent to every age. It reiterates the injunction of the Master in his discourse on the same subject.

It is probable this last theory may be combined with some features of the historical system; but until the great drama is nearly closed, it will not be possible to prove that the Apocalypse presents a series of predictions to be historically fulfilled. Meanwhile there can be no question that the practical value of the book for the Christian life is furthered by the "ethical" theory of interpretation far more than by any of the others.

Literature.—The BRITANNICA fails to notice the immense British and American literature. The following list is selected exclusively from this class. The various articles on the Revelation, in Smith's *Bible Dictionary*, McClintock and Strong's *Cyclopædia*, the Schaff-Herzog *Cyclopædia*, each with a bibliographical list; the prolegomena to the *Commentaries* of Stuart, Alford, Lee (*Speaker's*), Milligan (*International*); Schaff, *History of the Christian Church*, vol. i. (1882), pp. 385-390, 416-422, 825-853; Godet, *Studies on the New Testament*, Eng. trans., pp. 294-398; Farrar, *Early Days of Christianity* (N. Y., 1882), vol. ii, pp. 103-352; Trunch, *Commentary on the Epistles to the Seven Churches* (2d ed., London, 1861); Wordsworth, *Lectures on the Apocalypse* (London, 1852); Elliott, *Horæ Apocalypticæ* (5th ed., 1862); Milligan, *The Revelation of St. John*, Baird Lecture for 1885 (defending the ethico-spiritual theory of interpretation).—*Commentaries*: Moses Stuart, new ed., 1864, (præterist); Alford's *Greek Testament*, vol. iv. (historical); Lange and Craven, *Lange's Commentary*, vol. x., New Testament, 1874; Lee in *Speaker's Commentary*, 1881 (historical); Milligan, *International (or Popular) Commentary*, vol. iv. (New York, 1883). The older literature is of im-

mense extent, but the movement of history has shown most of the detailed expositions to be false and fanciful.

(M. B. R.)

REVERE, PAUL (1735-1818), immortalized by one of Longfellow's poems, was born in Boston, Jan. 1, 1735. He was of Huguenot ancestry, and was trained in his father's trade as a goldsmith. In 1756 he served as a lieutenant of artillery at Fort Edward, near Lake George. After establishing himself as a goldsmith at Boston he learned the art of copper-plate engraving, and produced in 1766 a print emblematic of the Repeal of the Stamp Act. Others of his designs were the Boston Massacre (1770), Landing of British Troops in Boston (1774). In 1775 he engraved the paper money ordered by the Massachusetts Congress. He was also commissioned by that body to learn the art of making gunpowder, and to set up a powder-mill. He took part in the destruction of tea in Boston harbor. On the night of April 18, 1775, occurred his famous ride, in which he notified the people of the British expedition to seize the military stores at Concord. He was lieutenant-colonel of artillery in the State service during the Revolution, and was engaged in an expedition to the Penobscot in 1779. After the war he was engaged in copper rolling at Canton, Mass., which business has long been carried on by the Revere Copper Co. He died at Boston, May 10, 1818.

His grandson, PAUL JOSEPH REVERE (1832-1863), graduated at Harvard College in 1852, served with distinction in the civil war, rising from major to colonel, and was killed at the battle of Gettysburg. Another grandson, E. H. R. Revere (1727-1862), was surgeon of a regiment and was killed at the battle of Antietam.

RÉVILLE, ALBERT, French author, was born at Dieppe, Nov. 4, 1826, where his father had been pastor of a Protestant church. After entering the ministry he was vicar at Nîmes, then pastor at Luneray, and in 1851 was called to the charge of the Walloon church at Rotterdam. At various times he returned to France to take part in the religious conferences, at which he advanced rationalistic and non-Christian views. In 1880 a professorship of the history of religions was formed in the Collège de France, at Paris, and Réville was called to the chair. In 1886 he was called to preside over the section of religious studies in the school of higher studies then established in the old Sorbonne. Besides translations from the English and German he has published *Essais de critique religieuse* (1860); *Histoire du dogme de la divinité de Jésus Christ* (1869); *L'Enseignement de Jésus Christ* (1870); *Prolegomènes de l'histoire des religions* (1881); *Les Religions des peuples non-civilisés* (2 vols., 1883); *Les Religions du Mexique, de l'Amérique centrale et du Pérou* (1884).

REVIVAL, RELIGIOUS. It is a historic truth that the spread of Christian doctrine and Christian life has not been uniform in its rate of progress. The growth of the church was much more rapid in the apostolic age than it has been at any subsequent period. Before the apostles had passed away Christianity had entered the imperial palace at Rome, and its doctrines were taught and embraced in all parts of the empire. In three hundred years from the death of Christ the Pagan empire had passed away, and the Christian empire had taken its place. We look in vain to see any such movement of conquest or of missionary effort on the part of the church after these early centuries until the renewed zeal of the Roman church appears in the 16th century, as awakened by the great separation from that church in the Reformation, and by the discovery of new continents beyond the Atlantic. Very much of the growth indicated both in the time of Constantine and in that of Xavier was superficial, and had no relation to conviction and to spiritual life. Political agencies and personal advantage were prominent factors in the establishment of the nominal church when worldly power was centred in its hierarchy, which of course cannot be alleged regarding the progress of Christianity at the first, when persecution and death attended the Chris-

tian profession, and the doctrines preached antagonized the natural passions of men.

But it is also historically true that in the growth of the church there have been periods when spiritual religion especially flourished in certain localities, where a new devotion has marked the lives of Christians, and great numbers have been added to the church from deep conviction, in true repentance and with sincere faith.

It is to these movements that the name of Revivals is generally applied. Two theories obtain concerning them—one that they are the direct result of human machinery, if we may use that term in a qualified way, and the other that they are entirely of divine origin and production, not dependent in any sense on human action. Under the former theory a revival can be had almost whenever the church wishes, and under the latter no church effort is of any avail. Under the former theory there is danger of a mechanical process being inaugurated, and men busy themselves in "getting up" a revival, as they would a concert or a fair. In such cases the door is open for all sorts of extravagance, discreditable to the name of religion. Under the latter theory there is danger of apathy, and men cease to feel their responsibilities as Christians with a divine commission to evangelize. The truth lies between the two theories. The essential power in a revival is undoubtedly the Spirit of God, but it is no derogation from his prerogative that he works through the faithful sons of men, and we may hence believe that a prayerful state of the church will be accompanied with spiritual enlargement and numerical growth. If the church were always equally prayerful (and by that is implied a true life) we might expect a steady and rapid growth instead of sporadic starts and ensuing stagnation.

In point of fact, we have the alternations. We find historically that the beginning of this century developed, in the churches of Great Britain and America, a zeal for foreign missionary work. At the same time Bible societies and tract societies sprang up and scattered the written word over the earth in scores of languages. In America several special seasons of renewed fervor and large accessions to the church are noted, as the Great Revival or Awakening in the days of Jonathan Edwards (1751), and the later ones of 1831 (with which the name of C. G. Finney is associated) and of 1857. Some early revivals in Kentucky and other Western States, and that in Ireland in 1859-60, were remarkable for many manifestations of a physical character in the converts, which only a superficial criticism will attribute to hypocrisy or wantonness. It is not strange that when suddenly the great realities of the unseen world and the relations of a holy God to the human soul are made known, the body should be affected by the shock of surprise and fear sustained by the spirit. The reality and sincerity of these bodily affections we cannot doubt, while we also recognize the fact that such periods of excitement will induce evil men to ply their hypocrisies, and it is often difficult to separate the true from the false.

It is because of these evils which attach themselves to revivals that many Christians have no confidence in revivals, and dislike both the name and the thing. But this is hardly consistent with a discriminating piety that will encourage the true, even though the false is at its heels. As men are, and as the church is, it seems that Christians have to be awakened again and again to new devotion and zeal, and hence revivals are to be sought and expected, until the church shall have been fully consecrated to its evangelizing work as designated in the Saviour's commission: "Go ye into all the world, and preach the gospel to every creature."

(H. C.)

REVOLUTION, AMERICAN.—At the conclusion of the war with France in 1763 the heavy indebtedness of Great Britain induced the consideration of a plan of laying taxes upon her American colonies.

The supremacy of Parliament was regarded as sufficient sanction for this action, but the colonies had through the exercise of the power of self-taxation come to consider that power as of right belonging to them. Their charters, derived directly from the crown, asserted for them the same rights that Englishmen enjoyed at home, and this they construed to mean that as Englishmen could not be taxed except by the consent of their representatives, the same right appertained to the inhabitants of the colonies, and as they had no representation in Parliament that body could not impose taxes upon them. A resolution of Parliament passed in 1764 proposed the imposition of a stamp duty on the colonies. This resolution was followed by an act providing that the instruments of commerce should be null and void unless having a stamp, for which a duty must be paid. To the passage of this act opposition was made, and among other grounds upon that of the colonies having no representation in Parliament, to which reply was made that the colonies were virtually represented as were certain cities of Great Britain. The operation of this Stamp Act being suspended for a few months, the people of the colonies were hesitating as to the course they should pursue when Virginia, in May, 1765, adopted resolutions, offered by Patrick Henry, that denied the right of the British Parliament to impose taxes upon that colony, claiming that right exclusively for the legislative authority of the colony. These resolutions were well received throughout the colonies, especially in New England. The imposition of the stamp duty was regarded as the assertion of a right of taxation which if submitted to would lead to still further encroachments upon the liberties of the colonies and would place intolerable burdens upon them. A congress of the colonies was called and representatives from nine of the colonies met at New York, Oct. 7, 1765, those from Virginia, North Carolina, and Georgia being prevented from attending by the governors of those colonies. This convention asserted the freedom of the colonies from taxation except that imposed by themselves, and forwarded petitions to the King and Parliament.

The Stamp Act was disregarded by the colonies. The colonists agreed to purchase no goods from Great Britain and betook themselves to domestic manufactures. Their refusal to purchase articles of luxury and even of necessity of English manufacture brought great distress upon artificers in England. The Stamp Act was repealed in March, 1766, but the absolute supremacy of "the King in Parliament" was still asserted. The people of the colonies from this time assumed a more independent tone in regard to their relations with Great Britain.

In June, 1767, Parliament enacted a law placing duties upon glass, paper, painters' colors, lead, and tea, in the colonies. Commissioners were sent to Boston to enforce the collection of this revenue, and the opposition of the people and their threatening attitude induced the sending of troops and vessels of war to protect the commissioners. Two regiments were quartered in Boston from September, 1768, until after the street fight known as the "Boston Massacre" in March, 1770. The proposition made in Parliament to take persons charged with treason in the colonies to Great Britain for trial again aroused the opposition to the use of manufactured goods of Great Britain. The British manufacturers being again made to feel the consequences of "non-importation agreements" Parliament was induced to repeal the tax except as to tea. The colonists refused to import tea and the expected revenue from that source failed. A project in the interest of the East India Company for the direct importation of tea into the colonies aroused at the same time the jealousy of the merchants whose trade would thus be interfered with and the patriotism of the people of the colonies at large. The people regarded attempts to force tea upon them as intended to secure

the recognition of the authority of Parliament to levy taxes upon America, and became more determined in opposition. A convention at Philadelphia condemned the tax on tea and the attempt of the East India Company to force it on the colonies, and declared those who should countenance this scheme as enemies of the country. The opposition of the colonists induced the return to Great Britain of the ships that were conveying the tea, excepting those sailing for Boston, where there was a military guard to protect them. They arrived at that city, but the tea was thrown in the harbor by persons disguised as Indians, Dec. 16, 1773. Parliament in the following March, indignant at this outrage, directed the port of Boston to be closed. An attempt was also made to change the charter of Massachusetts so as to deprive that colony of popular representation in one branch of its Legislature and to substitute appointees of the Crown. The authority of the town-meetings and the selection of jurors were interfered with to secure more perfect subjection to the authority of Parliament. The governor was allowed to send persons charged with murder or other capital offences to Great Britain for trial. These measures excited the indignation of the people of all the colonies. It was recognized that all the colonies had a common cause in opposing these laws, as they were an attack upon American liberty that would finally embrace all of the colonies.

By the Quebec Act an attempt was made to enlarge the government of that conquered province so as to encroach upon the colonies and to promote the interest of despotic rule in America. Throughout the colonies the people assembled and expressed in resolutions their sympathy with Boston and their common interest in the events there taking place. "Committees of correspondence" were appointed to facilitate inter-communication throughout the colonies. The situation was intensified by the exhibition of a greatly increased military force in Boston. The inhabitants of that liberty-loving town suffered from the closing of their port, but received assistance from Salem and other neighboring towns, whose ports derived commercial benefit from the misfortune of Boston. This advantage to the neighboring ports had been counted upon in Great Britain as likely to detach them from the interests of Boston. A league and covenant against trade with Great Britain was made by the colonists, and denounced as traitorous by that government, and those connected with it ordered to be arrested.

The plan of reorganizing the government of Massachusetts was deprived of practical efficiency by the excitement and rising of the people of that colony and their taking the public authority in their own hands. A committee of safety was appointed at Boston and "minute men" selected to stand ready at any moment for such military duty as might be required of them. Other colonies united with Massachusetts in such military preparations. Seizures of arms and ammunition took place in various localities. A provisional Congress in Massachusetts replaced the regular Legislature and sustained the popular rights as against the Crown. A Continental Congress was convened in Philadelphia, Sept. 5, 1774, and twelve colonies were represented in it. The Congress was loyal to the Crown, but devoted to the rights of America. In this Congress controversies as to the relative claims of large and small colonies to representation led to a single vote being allowed to each.

Congress assented to the regulation by Parliament of the external commerce of the colonies, but declared the invalidity of attempts to impose taxation without the consent of the colonies. It demanded the rights of the common law of England as to trial by a jury of the vicinage, and insisted upon the immunities secured by their charters. It claimed the right to assemble and petition for the redress of grievances, and against the presence in the colonies of a standing army.

It also protested against selection by the Crown of councillors to take part in the legislation of the colonies. It demanded the repeal of the obnoxious acts as violations of the rights of the colonies, and enumerated such acts, including those already mentioned, as open to such objections. It recommended non-intercourse, non-consumption, and non-exportation, and the stoppage of the slave-trade.

Upon the report of these proceedings, Parliament sanctioned the ministerial plan of increasing the military force in the colonies, 10,000 men being provided for Boston. As a retaliatory measure a bill was passed in Parliament to prevent intercourse between the colonies and other British possessions in America, having special reference to the colonial trade with the West Indies and the fisheries, which the colonies held in high estimation.

In the meantime military activity commenced. A hasty expedition to destroy military stores that had been accumulated at Concord first brought the British troops into conflict with the people, armed and banded. In the skirmishes at Lexington and Concord, April 19, 1775, the first blood of the impending conflict was shed. The news of these fights roused to greater intensity the patriotic ardor of the colonists everywhere, and the battle of Bunker's Hill, June 17, determined irrevocably the issue as one of arms. The Congress at Philadelphia had recommended at its adjournment the calling of another Congress in the following year. That body, when it assembled in May, 1775, advised a defensive attitude, but that the building of fortifications by the royal governors should not be permitted, and recommended that more rigid provisions should be made as to non-intercourse with the British possessions. It established a general post-office and made a declaration of its position as loyal to the mother country but determined to resist tyranny by force. Washington was at this time appointed commander-in-chief of the provincial forces, and provision was made for raising troops, bills of credit being issued for that purpose. With all its caution in holding to established forms and its professed loyalty to the Crown, this second Continental Congress was a purely revolutionary body.

During the year 1775 the King proclaimed the existence of open rebellion in the American colonies, and Parliament made the necessary military preparations for war with them. It passed an act to compel all Americans found in captured vessels to serve as seamen in the British service; foreign troops were engaged under treaty with Hesse-Cassel for service in America, and Sir William Howe was placed in chief command. These actions of both King and Parliament had their reaction in the colonies by stimulating the growing desire for independence until it culminated in the Declaration of Independence. (See INDEPENDENCE, DECLARATION OF.) This measure, adopted July 4, 1776, by a nearly unanimous vote in Congress, was the starting point of American nationality. With this declaration British sovereignty was denied throughout the colonies and public authority exercised in the name of the people. The colonies assumed the title of States and reorganized their internal governments. While the Declaration of Independence was under consideration, measures were being taken to bring about more definite confederation among the States. The scheme of confederation was carefully considered with a view to securing the proper conduct of those matters of common interest, bearing directly and indirectly upon the existing state of war, that demanded a common authority of confederated States. Articles of Confederation were passed by Congress in 1777 and ratified in 1778 by all the States, except Delaware and Maryland, and subsequently by these States. (See CONGRESS.)

The important advantages of an alliance with France early attracted the attention of Congress, and in 1776 commissioners, of whom Benjamin Franklin

was one, were sent to negotiate such alliance and to seek aid from France and the French people. In the latter part of 1777 proposals were made to the commissioners on the part of the French government embracing the acknowledgment of the independence of the United States and aid towards the maintenance of that independence, upon the condition that no return to obedience to Great Britain should take place on the part of the States. A treaty was concluded in 1778, one of the motives to which on the part of France was a desire to diminish the commercial advantages of Great Britain. This treaty was one of amity, commerce, and alliance, no special advantages either political or commercial being conceded to France as the price of this friendly act on her part. A secret provision was made for the admission of Spain to the alliance.

The British Parliament on learning the state of relations between France and the States promptly passed conciliatory acts intended to win the States from this alliance to their former relations to the British government, but Congress as promptly declined to accede to the terms of conciliation proposed. A cessation of hostilities was embraced in the proposition on the part of Great Britain, looking to the restoration of amicable relations under the sovereignty of Great Britain and tending to place the States in a federal relation to Great Britain that would secure to them a large control over their internal affairs. To this proposition the reply of Congress was, that while desiring to conclude an honorable treaty of peace the idea of dependence upon the Crown could not be entertained. The alliance between France and the States involved that country in war with Great Britain, to which ultimately Spain became a party, and British interests suffered from these combined enemies.

The financial condition of the new nation embarrassed its military operations. As the first preparation for war had included the emission of bills of credit, so that source of obtaining the supplies necessary to carry on the war was resorted to until its exhaustion in 1780. Congress had no authority to enforce taxation within the States or to compel them to contribute their just proportion to the public service, and hence the resort to the issue of bills of credit was the only available means of raising revenue within the power of Congress. The credit of these bills was for a time sustained, but at last, as the emission was continued from year to year, decline in their purchasing value commenced, and continued until the issues had reached two hundred millions, when the depreciation was so great that necessity compelled a resort to other means. Resort was had to forced contributions exacted by the military power as necessary for its maintenance. An attempt was made to obtain from the States material supplies in lieu of their quotas of money, but failed. An attempt was also made to absorb this currency by taxation and to replace it by new issues, but this was not successful. (See FINANCE, *Revolutionary Period*.)

While affairs in the States were apparently approaching a failure of the resources for maintaining the war the difficulties surrounding the British position in Europe were increasing. The opposition of the states of Europe to a British monopoly of American trade had already engaged France and Spain in hostility to that country, and the motive to open commerce with America operated upon other powers. The rigor with which Great Britain exercised belligerent rights upon the seas interfered with neutral trade and led to a proposed coalition, termed the armed neutrality, intended to support more liberal ideas of neutral rights. Holland became involved with the American question, and war was declared against her by Great Britain. The years 1780 and 1781 were the culminating point in the financial embarrassment of the country. The failure to pay the troops, their sufferings for want of supplies, and their retention after their term of enlistment had expired from inability to

refill the ranks as rapidly as was required, produced mutiny in a portion of the army, which, however, was readily quelled without resort to force and without any advantage resulting to the enemy therefrom. The depreciation of the bills of credit which brought on these difficulties at last caused their withdrawal from currency. Relief came to the finances of the country from its friendly relations with European powers, loans and other transactions being made that brought gold and silver into the country. Advantage was taken of this circumstance to place the transactions of the government upon a coin basis, and this change, with the accession of Robert Morris to the financial management, gave partial relief to the overstrained financial situation. The depreciated currency by common consent passed out of circulation without popular commotion, as an expression of the patriotic sentiment of the country. Before the close of the year 1781 the tide of military affairs had turned in favor of the American arms, culminating in the surrender of the British force under the command of Lord Cornwallis, at Yorktown, Oct. 19.

In 1782 a pacific feeling developed not only in Great Britain towards the States but among the European belligerents involved in the American question. The disposition to treat with the States on the basis of independence appeared in Parliament and a change of ministry gave an impetus to the movement. Commissioners were received from the American Congress and negotiations entered upon. John Adams, Benjamin Franklin, John Jay, and Henry Laurens constituted this commission. Provisional articles of peace were agreed upon between Great Britain and the United States, to be inserted in the future treaty of peace. To such treaty France was to be a practical party. By these articles the independence of the United States was fully recognized, with liberal boundaries, including the east side of the Mississippi and both sides of the Ohio, and a right of free fishery secured on the Banks of New Foundland. The treaty of peace following the terms of the articles was concluded at Paris, Sept. 3, 1783, thus terminating the American Revolution, and placing the United States in general recognition as a sovereign national power.

See Ramsay's, Hildreth's, and Bancroft's *Histories of the United States*. For an outline of the war by which American independence was achieved see the following article.

(A. J. W.)

REVOLUTIONARY WAR, AMERICAN. This war began in a revolt of the American colonies of Great Britain, which colonies soon after constituted the thirteen United States. The first skirmish between organized forces took place at Lexington, Mass., April 19, 1775. The preliminaries to peace were signed at Paris, France, Nov. 30, 1782; so that a state of war existed for seven years and seven months.

The Causes.—The Declaration of Independence, issued by a Congress of Delegates July 4, 1776, explicitly sets forth the grounds of separation from Great Britain, and these were substantially the causes of the war. Two expressions therein appear to summarize the views of those who resisted by arms the forces of the mother-country. First, "When a long train of abuses and usurpations, pursuing invariably the same object, evinces a design to reduce them (the people) under absolute despotism, it is their right, it is their duty to throw off such government and to provide new guards for their future security." The second is: "The history of the present king of Great Britain is a history of repeated injuries and usurpations, all having in direct object the establishment of an absolute tyranny over these States."

Not only the claims of the tyrannous king, but the Acts of the British Parliament which sustained him, were the grievances detailed in that Declaration. The most vehement protest therein is against attempts at taxation without representation. But long before

the Declaration, the home government had undertaken by its army and navy to enforce its measures and to compel its subjects in America to submit to its exactions. This positive action was resisted by open force till all the new States became united and put an army into the field, and so the primary revolt became a *bona fide* revolution. The new army is usually named the American or Continental troops. The central supreme authority was vested in the general Congress. The very existence of this Congress was in the eyes of the British Cabinet and Parliament a cause of war, and continued so till at its close the independence of the States was acknowledged.

First Campaign, 1775.

The people of Boston and the vicinity had been forward and persistent in their opposition to the unfriendly acts of the British government until, to withstand them, several war measures were set on foot. The first showed itself in the action of Gen. Thomas Gage, the royal governor of Massachusetts. He brought from Halifax to Boston two regiments of the line, and promised his king "with five regiments to keep Boston quiet!" Next came the proclamation and enforcement by Gen. Gage of the Boston Port Bill, which went into operation June 1, 1774, and effectually closed the port. The custom-house was removed to Salem, and the Bostonians were subjected to the hardships of a regular blockade. About this time the British reinforcements called for came, raising the forces to upwards of 10,000 men, exclusive of the naval squadron numerous enough for the work assigned to it. With these troops appear the names of Gens. Howe, Burgoyne, Sir Henry Clinton, Lord Percy, and Lord Rawdon; names which in the war became famous as able commanders.

Gen. Gage began his operations as if to subdue and control a riotous city. He encamped his artillery on Boston Common, crowned Fort Hill with Welsh soldiers, and sent a field-battery to hold Boston Neck, the only land entrance to the city.

Affairs of Lexington and Concord.—Next, in his double capacity of governor and general, Gage directed that all the munitions of war within his precincts be brought forthwith to Boston. To make a beginning he sent out two companies which in the night removed a large quantity of powder from Charlestown to the city and deposited it in Castle William. This act excited indignation and alarm among the patriots in the surrounding country, and they quickly armed themselves and ran together at their appointed rendezvous. On April 19, 1775, 800 "loyalists," in two detachments commanded by Lieut.-Col. Francis Smith and Maj. Pitcairn, were marching toward Concord, 16 miles from Boston, where they were to seize and destroy sundry military stores which the general's spies had there found. At Lexington the advance was resisted by about 70 militiamen under Capt. John Parker. The British, after short parley, fired upon the patriots, killing 8, including Capt. Parker, wounding 9, and scattering the remainder. In this encounter but one "loyalist" was wounded. The patriots in greater numbers next gathered near Concord; quite a battle took place; and the return march of the British, from the incessant flanking and pursuit of their ever-increasing foes, who had put themselves under the able Gen. William Heath, became an annoying and finally a disorderly retreat. On arrival in Boston they found that they had lost 68 killed, including Lieut.-Col. Smith, 178 wounded, and 26 missing. The patriot loss was 101 put *hors de combat*. Thus the campaign was opened.

Ticonderoga, Crown Point, and Fort St. Johns.—Benedict Arnold, who came to Cambridge from New Haven with a company, proposed plans to committees of safety of Massachusetts and Connecticut for seizing Ticonderoga and other forts; having received authority and commission of colonel he began enlisting men.

But the Connecticut people, improperly using his plan, arranged another expedition. Some of their own men joined the "Green Mountain Boys," making in all about 140 soldiers under Col. Ethan Allen. Arnold, without troops, overtook Allen at Castleton, but not being allowed to command according to his commission, he nevertheless went with the expedition. May 10, 1775, they surprised the garrison. The startled commander, Capt. Delaplace, yielded to the inevitable, surrendering 2 officers and 48 men, 182 cannon, and an abundance of public stores. Col. Seth Warner, with a detachment of these patriots, captured Crown Point, May 12, with 11 prisoners and 111 pieces of artillery. A number of Col. Arnold's men having come, he and Allen put on foot, on May 14, two expeditions against St. Johns, situated near the foot of Lake Champlain. Arnold surprised the fort, took the small garrison prisoners, and departed, carrying off a sloop of war manned with 16 guns, and many stores. Allen arriving a little later, with his 60 men, took possession of the abandoned fort. But during the ensuing night a British officer having 200 men and a 6-gun battery arrived, when Col. Allen with his "Green Mountain Boys" was dislodged.

First Naval Affair.—Meanwhile, on the coast of Maine, occurred an amateur naval encounter. The *Margaretta*, a British armed sloop, carrying 4 six-pounders, 20 swivels, 2 wall-pieces, and plenty of small arms, early in May convoyed two other sloops to Machias, Me., for lumber. The war news from Lexington arrived Saturday, May 9. Sunday several patriots undertook to seize the captain, Moore, and his officers at church. They escaped by the windows. The *Margaretta* gave the town some parting shots and dropped down the bay four miles. Monday, Joseph Wheaton and several patriots seized one of the sloops and, armed with fowling-pieces, pitchforks and axes, and small supplies, gave chase. The sloop, a swift sailer, overtook the *Margaretta* after she had put to sea, engaged her at close quarters, and after a hard but brief struggle, in which Moore himself was slain, captured the vessel and all on board, 40 in number. This feat is called "The Lexington of the sea."

East Boston was in 1775 Noddle's Island; and Hog's Island is to the north-east. These were used largely for stock. To save the herds from capture the committee of safety sent, the 27th of May, a detachment to escort them back into the country. Forty British marines resisted, killing horses and cows and doing much other damage. Seeing the situation Col. Israel Putnam and Dr. Joseph Warren brought up reinforcements, drove off the marines, and finally captured their armed schooner, which Putnam dismantled and burned. Putnam's rapid advance to the rank of Major-General in the Continental army is attributed to this fortunate skirmish.

Bunker's Hill.—By the second week in June, 1775, there were gathered from different States, in the outskirts of Boston, about 15,000 men. "They were subordinate through inclination . . . depending for sustenance on supplies sent from their several towns." Gen. Artemas Ward, the nominal senior, was at Cambridge with 9000 men; Gen. Thomas, second in command, with 5000 more, and 3 or 4 batteries, held the right at Roxbury and Dorchester; while the left, a thousand strong, principally of New Hampshire volunteers, extended to the bay. This force, oddly armed and strangely clad, were making a partial siege of Boston. Learning that Gen. Gage intended a series of operations, beginning with the taking of Dorchester Heights the night of June 18, these patriots determined to anticipate his action. So Col. Prescott, with a thousand soldiers with two pieces of artillery and intrenching tools, at 9 p. m. on the 16th marched to seize and fortify Bunker's Hill; but Breed's Hill, a little nearer Boston, was first taken and intrenched; and Bunker's Hill afterwards crowned with a redoubt. About noon the British troops under the immediate

command of Gen. Howe moved up to the assault of the works on Breed's Hill. He took the right, Gen. Pigot the left, while Gen. Sir Henry Clinton brought up the reserves. Thousands of spectators, on points of observation, eagerly watched the splendid panorama. The British were twice terribly repulsed. At last, about 4 p. m., Howe succeeded in gaining the hill, and Col. Prescott slowly drew off his forces, via Bunker's Hill, across the Neck to his camp of the previous day. Howe had in action between 3000 and 4000 men; Prescott not to exceed 1500, after the reinforcements came to him. Howe's loss, killed and wounded, was 1054; Prescott's, including the missing, was 449. Notwithstanding the loss of the field, this battle was to the patriots in its results equivalent to a victory.

The Evacuation of Boston.—Washington having been made general-in-chief, arrived and took command July 3, 1775. Discovering the enemy's disciplined force to be 11,500 strong, and his own mostly raw levies not to exceed 14,000, he saw that more men were needed for the siege. He asked for a force of 22,000. Soon recruits flowed in; but there were on hand less than 10,000 lbs. of powder. "The Continental army" was now organized. Two brigades, Thomas' and Spencer's, made the first division under Maj.-Gen. Ward; Sullivan's and Greene's the second division under Maj.-Gen. Lee, and there was a reserve of six regiments under Maj.-Gen. Putnam. Gradually, awakening a few skirmishes and bombardments from the British redoubts and war vessels, Washington closed in, till land-egress from Boston was cut off. American cruisers, authorized by Congress, began to worry the British squadron. They captured supply vessels *en route* to Boston. On Oct. 10, 1775, Gen. Gage gave up the city to Gen. Howe and sailed for England. Washington for good reasons threatened but constantly postponed a general attack; but by night enterprises he seized important heights that commanded the city. In rebuttal, Gen. Howe made ready to assault Dorchester Heights the night of March 5, 1776, and Washington, knowing his intention, planned to enter Boston from the opposite quarter. Providentially a terrific storm prevented the movement, and, in view of growing want and harassment, however humiliating, the proud British general decided to evacuate Boston. By a tacit understanding Washington was not to fire upon the retiring army if the city were spared. So, on March 17, Howe's forces embarked and put to sea, escorted by the naval squadron, except a small fleet under Commodore Banks left to keep possession of the harbor entrance. After enduring for some time this annoyance, Gen. Lincoln with 1200 troops, including artillery and a mortar equipment, was sent to dislodge the fleet. From Long Island and some other convenient points he at last brought his guns to bear upon the shipping; so soon as the commodore's flagship was reached by the shot, he gave the signal of departure. The fleet left June 18. The spreading news caused great rejoicing to the patriots and unstinted praise to Washington and his coadjutors.

Expedition against Canada.—The early enterprise of Allen and Arnold, near Lake Champlain, caused other northern expeditions. Sir Guy Carleton, governor of Canada, inaugurated movements to recover his captured forts. Gen. Schuyler, stationed by Washington at Albany, and later at Ticonderoga and Fort Edwards, as a sort of department commander, was watching Carleton's operations, effected largely by "Tory" levies and hired Indians. In June, 1775, he was sent to command in an offensive expedition. He led an army of some 2000 men to go by the way of Vermont and Lake Champlain; but becoming suddenly ill, was replaced by Gen. Montgomery. The latter captured Fort Chambly, St. Johns (which Allen had lost), and Montreal, and then pushed on down the St. Lawrence to the vicinity of Quebec. Gen. Arnold, with fuller instructions directly from Gen. Washington, made an

extraordinary march through the forests of Maine and succeeded in forming a junction with Montgomery. After a partial siege, the works of Quebec were, on Dec. 31, during a winter storm, simultaneously assailed by several attacking columns. The patriots were at last repulsed, Arnold badly wounded and the brave Montgomery slain. The little army, held together by Arnold, spent the winter a short distance from Quebec. Arnold's wound, opened afresh by an accident, caused his relief of command. His successors were finally, by the middle of June, 1776, forced from Canada by the famous Burgoyne, who, with large reinforcements to Carleton, had appeared on the scene. But the main cause of all disasters in this well-planned campaign was a continued insubordination. For the patriots it required time and mutual suffering to allay such sectional jealousies as weakened and at last destroyed this important expedition.

Great Bridge.—Lord Dunmore, governor of Virginia, declared martial law, perpetrated a series of depredations, began to use Tories and Indians, and spread terror far and near. His forces assembled near the armed vessels at Norfolk. He planned the destruction of military stores at Suffolk. To hinder this, Col. William Woodford led his troops, about a thousand strong, in that direction. Anticipating patriot Woodford's design, the governor dispatched about 200 regulars and some 400 others with artillery to the "Great Bridge" across the Elizabeth River. Here the commander intrenched impregnably and covered every approach. But Woodford by a ruse drew an attack upon his men in position and so completely defeated his adversary, Dec. 9, 1775. Fordyce, leading the grenadiers, lost 60 men and his own life. Woodford seized Norfolk, but the enemy, taking shipping, burned the town.

Second Campaign, 1776.

The British ministry planned first to aid their Southern colonial governors and then combine all their powers, military, naval, and diplomatic, to get possession of New York and make that city their principal base. Accordingly on Jan. 12, 1776, Lord Cornwallis set sail from Cork with some six regiments, under escort of Admiral Sir Peter Parker, with a large naval contingent. On May 3 the fleet arrived at Cape Fear, N. C. Sir Henry Clinton assumed command and moved against Charleston. It was there at Sullivan's Island, June 28, that Col. William Moultrie with a few hundred men successfully resisted the combined attack. Without further effort Sir Henry now joined Gen. Howe at Staten Island, the Admiral Lord Howe having there the naval fleet. The incoming Tories gave Gen. Howe hopes of a speedy peace. The royal land troops here amounted to 35,000 men, well supplied. Gen. Washington had possession of New York with his army, such as it was, of about 17,000, and had, after leaving Boston, been busy fortifying all approaches. He put Gen. Greene over the works in the outskirts of Brooklyn, L. I., giving him between 5000 and 6000 men. Greene on the eve of battle had a violent fever and was replaced by Gen. Putnam. His line stretched along the Bedford Ridge in crescent shape; his right wing under Lord Stirling and his left, considerably extended, under Gen. Sullivan. For some unaccountable reason Putnam immediately withdrew his mounted patrols on the Bedford road which led beyond his left through Bedford pass. Gen. Howe first crossed his command to Long Island, took position in front of Putnam, and reconnoitred for three days. He formed three columns for attack, Gen. Grant's opposite Stirling, Gen. De Heister's breasting Sullivan, and Sir Henry Clinton's to aim for the Bedford pass.

Clinton commenced his march at 9 P. M., Aug. 26. He captured a scouting party *en route*, and by daylight the pass, being unoccupied, was held secure. After breakfasting he pushed on through Bedford, driving detached patriot regiments before him, till he struck

Sullivan's rear. Gen. Grant, also moving in the night, began to encounter Stirling's outer lines after midnight. Probably Putnam believed this the main attack. De Heister remained quiet till about daybreak. Hearing that Sir Henry already had the Bedford pass, he pushed on and furiously assailed the position of Sullivan in front. A terrific conflict ensued throughout the field. Putnam was dislodged and badly beaten.

Gen. Washington, however, reinforced the Brooklyn redoubts in time to save a greater disaster. Howe's loss was about 400, while Putnam's was 1200 at least.

Battle of White Plains.—Gen. Washington stood on the defensive till the 29th, when he made a safe withdrawal and for a time posted his army in the northern part of New York Island, but afterward he withdrew to White Plains. Here Gen. Howe, much delayed *en route* by American detachments, at last confronted the Continental army. Washington warily avoided general engagements; but an important knoll, lying between the main bodies, was contended for. This gave rise to a lively action, Oct. 28, 1776. During the night following Washington again retired to North Castle, taking a strong position. From this Howe undertook to manœuvre him away by attempting to carry the forts on the Hudson. Divining Howe's intention Washington, leaving two detachments for observation and reinforcement, one under Lee at North Castle, and the other under Heath at Peekskill, crossed the main body into New Jersey. Without delay the patriot Col. Magaw, holding Fort Washington, was now attacked and defeated, but with heavy loss to the British. Fort Lee on the west of the Hudson was abandoned on the approach of Lord Cornwallis, who had taken the field with 6000 men. Washington deeming it unwise, at that epoch, to risk an engagement, retired before Cornwallis, till on Dec. 8 he passed the Delaware. It was a time of much discouragement to the patriots. Congress fled to Baltimore, while Washington as rapidly as possible gathered in his detachments. Gen. Charles Lee under these orders encamped one night in New Jersey far from his command and suffered capture, but Gen. Sullivan, his successor, speedily completed the march to Washington's position.

Battles of Trenton and Princeton.—Now, feeling a little stronger, the general, choosing a winter's night, Dec. 25, recrossed the Delaware, surprised at Trenton a large force of Hessians under Gen. Rahl and defeated them. Rahl was mortally wounded and a large number of prisoners taken.

For precaution Washington again passed the Delaware, but just then getting a moderate accession from recruits he went back again to Trenton. The delighted Cornwallis moved at once to Trenton, anticipating an easy victory. A small stream only was between the two armies as Cornwallis came into position near night, Jan. 2, 1777. Washington, hearing of a British division left back at Princeton, cautiously withdrew. At sunrise he struck that division in motion. His militia in advance acted disgracefully, but the general with other trusted brigades soon checked the hopeful enemies and put them to flight. The patriot Gen. Mercer was fatally wounded and 30 men only put *hors de combat*.

It was during this spring of 1777 that the patriot cause began to receive some help from abroad. The gallant young Marquis de Lafayette from his private funds prepared a vessel and joined, as a volunteer without pay, the Continental army. Soon Congress gave him a commission of major-general. No American forgets his generous and soldierly assistance. Washington, a master of strategy, proceeds to Morristown and Middlebrook and so threatens Howe's communications till, weary of fruitless efforts, he withdraws to Staten Island.

There were several small expeditions on both sides. In that to Danbury, Conn., Gen. Tryon destroyed quantities of stores and burnt the village. The Connecticut militia under Sullivan, Arnold, and Worcester

accomplished wonders, pestering Tryon's return march. He lost some 300 soldiers before he reached his shipping. The militia suffered considerably, Gen. Worcester being among the slain.

The patriot Col. Meigs about the same time succeeded in burning the British shipping at Sag Harbor and large quantities of supplies.

Third Campaign, 1777.

The next project of the British was for Gen. Howe, co-operating with Admiral Howe, to capture Philadelphia and clear out there all obstructions and hostile forces; also for Gen. Clinton, left at New York, to hold that base, open up the Hudson, and finally form junction with Burgoyne's army coming down from Canada. The admiral took on board 18,000 men and Gen. Howe in command, and set sail. As soon as Washington ascertained their destination to be the Chesapeake and Philadelphia he hurried forward his little army and offered battle. The position was the eastern bank of the Brandywine, Chadd's Ford being the centre. He deployed along the creek. Sullivan commanded the right wing; Wayne had Chadd's Ford; Armstrong took the Pennsylvania militia, *i. e.*, the left; while Greene held one division in reserve. The British commander on Sept. 11, 1777, masked Washington's front by Knyphausen's command. From a road fork to his rear, Howe sent the rest of his army under Cornwallis 17 miles around his enemy's right. The attack on Sullivan's right rear was almost a surprise. There was desperate fighting; Sullivan was defeated, but Gen. Greene got to him in time to cover his retreat. Wayne held his own against Knyphausen till the other operations forced him to retire with the whole left. Washington suffered a great discomfiture, but by Howe's delay he reorganized at Chester. Lafayette, of Washington's staff, served by request with Sullivan and was wounded. Congress left Philadelphia that night for Lancaster. Washington on the 12th succeeded in crossing the Schuylkill to Germantown. Wonderful to tell, this defeated army recrossed the Schuylkill Sept. 14, and again confronted Howe for battle; a fearful storm of 24 hours' duration alone prevented a desperate conflict. With ammunition wet, Washington disappointed drew off. He crossed the river again at Parker's Ford, but sent back Wayne and Smallwood with about 1500 men to strike Howe's trains. The effort brought on the affair of Paoli, Sept. 20, 1777, where the over-confident Wayne allowed himself to be surprised and defeated. Gen. Howe next, on Sept. 21, pushed up the right bank of the Schuylkill. Washington followed the movement abreast on the other bank to Pott's Grove. Suddenly, on the night of the 22d, Howe marched back, crossed the Ford and entered Germantown. This time Washington was out-manœuvred. On the 26th Howe sent Cornwallis to Philadelphia, who with much pomp took possession of the capital city. Meanwhile Gen. Washington remained in position, drawing in detachments and giving his army a much needed repose.

Burgoyne's Operations.—Gen. Burgoyne left Canada the middle of June, 1777, with 10,000 men including Indians. The American Gen. Schuyler, at Fort Edward, N. Y., opposed him, and under Schuyler, Gen. St. Clair with 3,000 men garrisoned Fort Ticonderoga. Burgoyne drawing near seized Mount Defiance and planted batteries completely dominating the fort. St. Clair, too late apprised, retreated, aiming for Fort Edward. Burgoyne pursued and struck his rear division at Hubbardton and routed it and secured a large quantity of provisions. Schuyler, always wary, retired as Burgoyne advanced, obstructing his way and defeating his detachments. Burgoyne sent St. Leger with regulars and Indian allies to besiege Fort Schuyler. The patriot Gen. Herkimer, coming with relief for the garrison, was mortally wounded and his men repulsed, but Arnold's approach dispersed the Indian allies and St. Leger abandoned his effort.

Again Burgoyne detached Col. Baum with a few hundred men to gather supplies accumulated at Bennington. Gen. Stark, a New Hampshire brigadier, quickly gathered his brigade and volunteers 2000 strong. He gave battle near Bennington Aug. 16. Baum was defeated, as was also a reinforcement hastening to his support. 1500 in all. Stark's effort cost him 50 men, while Baum's dead alone were 207.

Battle of Bemis' Heights.—Gen. Schuyler had effected his purpose. Having depleted his enemy and organized against him more than 6000 men, he took position near the mouth of the Mohawk. Just then Gen. Gates, sent by Congress, replaced Schuyler. Arnold chose for him a good position at Bemis' Heights. Kosciusko, the engineer, fortified it and the army took possession. Gates kept command of his centre and right near the Hudson River; the left was given to Arnold. Burgoyne still had about 7000 men; he assaulted with the usual three columns. The right one under Gen. Frazer sought a ravine on Arnold's left. Gen. Riedesel led a column on the other flank, while Burgoyne himself pushed forward the centre. Early on Sept. 19, 1777, the battle began, and raged for four hours. Gage had effectually stopped his enemy's advance, but yielded the field of battle, retiring a short distance without disorder. The British lost 600, Gates 321. Burgoyne waited for help from New York as long as he could, but receiving none he began, on Oct. 7, a tentative movement to cover a forage train, but so near Gates' camp that it brought on another battle, though not very decisive. The patriots lost 150, with Arnold among the wounded. The British lost between 500 and 600. Gen. Frazer was fatally injured. This is usually called the Battle of Saratoga. Retiring to Saratoga proper, Oct. 17, 1777, Burgoyne surrendered after his losses an aggregate of 5000 men. Gen. Clinton had sought to co-operate. He had attacked and captured Forts Montgomery and Clinton, and had foraged freely upon the country. After Burgoyne's discomfiture he burned Kingston and returned to New York. Ticonderoga and other Northern forts were at once abandoned by the British.

Battle of Germantown.—Gen. Washington left Pott's Grove and moved to Skippack Creek, 14 miles from Germantown. Gen. Howe had detached from this place quite a force to operate against the forts below Philadelphia, and another for supplies. Taking advantage of this, Washington decided to attack the remainder. A sharp engagement took place Oct. 4, but Howe, reinforced by Cornwallis, repulsed the attack. A heavy fog confused a well-planned effort, causing the loss of 1000 men. The British suffered a depletion of about half that number. Forts Mercer and Mifflin, on the Delaware, held by the patriots, were an annoyance to British transports. They were both attacked the same day, Oct. 22, 1777. Fort Mercer, on east bank, was assailed by 2000 men, Count Donop commanding, and Fort Mifflin, on an island, by the British vessels. Donop was mortally wounded, 500 soldiers disabled, and British ships dismantled. Another combined attempt began Nov. 10, using shore battery and war ships for five days. The garrison, driven out, fled to Fort Mercer, which itself was abandoned on approach of greatly increased British forces. Col. Samuel Smith led the heroic defence of Mifflin, Maj. Thayer replacing him when disabled by wounds. Col. Christopher Green, with 400 men, aided by Col. Hazelwood with two or three galleys, conducted the defence of Mercer.

Washington kept his army at Perkiomen Creek up to Oct. 30, when, reinforced by Varnum's Rhode Island brigade and perhaps 1000 besides, he again decided to give battle, advancing to White Marsh. Howe brought his army from Philadelphia to meet him, and after skirmishing for position from Nov. 5 to 8, made a precipitate retreat to Philadelphia. Soon

Washington's small army moved to Valley Forge for winter quarters.

Valley Forge has its own terrible history of privations and suffering, many officers leaving the service for want of pay. The patient commander held the remnant together in spite of rival malice. On the whole the patriot cause had gained during 1777. British sentiment was changing; the French acknowledged the new government, and was sending naval help under Admiral d'Estaing. Gen. Howe resigned, and Sir Henry Clinton took the chief command.

Fourth Campaign, 1778.

The British administration for a time seemed to weaken. During the spring and part of the summer Clinton planned merely to hold what he had. Foraging detachments from each army had bloody encounters at Quintin's Bridge, Hancock's Bridge, N. J., and at Crooked-Billet, Pa. Hearing of the movement of the French fleet, the British ministry feared that Clinton and his fleet might be shut in on the Delaware; so, under instructions, Clinton evacuated Philadelphia and returned to New York. This movement began June 18. Washington marched directly to intercept the British *en route*. He came so near to Clinton at Monmouth, N. J., that Clinton was forced to fight. Gen. Charles Lee, holding the advance and being already suspected of disaffection, ordered a retreat contrary to Washington's instructions. Being on hand, Washington prevented a disaster, but reprimanded Lee severely, who after that behaved well during the battle, and subsequently demanded redress. It resulted in his court-martial and dismissal. The battle of Monmouth was not decisive; but Clinton marched off before dawn the next day. In this retreat Clinton's total loss was 1500 men, and Washington's not to exceed 200. The former, on arrival at Sandy Hook, found Admiral Howe already there, and on July 3 he crossed his command in safety to Staten Island. Washington, on account of the great heat, halted for some time at Paramus, N. J. He then pushed up the Hudson and crossed, encamping again at White Plains: thus at will could he make junction with troops in the Highlands, support a projected eastern movement, or turn southward should Clinton's hostile plans so require.

The Rhode Island Operation.—Admiral d'Estaing at last arrived, but too late for co-operative moves on Philadelphia. Washington planned others against Gen. Pigot's command, then holding the island of Rhode Island and Newport. He was guarding a fortified depôt with eight or nine regiments and a naval squadron. Four or five Continental brigades gathered at Providence were soon reinforced by the brigades of Varnum and Glover. Gen. Sullivan was sent thither to command them. At Washington's solicitation d'Estaing left Sandy Hook and went to Sullivan's aid. He and the general agreed upon a combined assault of an island. Sullivan's militia not "coming to time," he asked of d'Estaing a postponement; after which, hearing that the island was vacated, he pushed over and took possession without consulting the admiral. D'Estaing was greatly offended, and instead of landing men as per agreement he dropped down where he could meet Lord Howe's fleet, reported to be coming from New York. A heavy storm forced both squadrons to sea and badly disabled them. Instead of returning after the storm, d'Estaing put into Boston for repairs. Gen. Sullivan was left to attempt alone what it plainly required a fleet to aid in doing. A battle at Quaker Hill was the result, in which Sullivan had the advantage: but hearing of Sir Henry Clinton's approach by shipping with large reinforcements, he hastened over the mainland and made good his retreat. The hard feelings that grew out of this affair caused great distress to Washington and Lafayette, and for a time injured the American cause.

Gen. Grey, a British officer, became as notorious as

did the Tory Gen. Tarleton, for merciless depredations and massacres, like that at Tappan, N. J.; but probably those massacres perpetrated by Tories and Indians combined, at Cherry Valley, N. Y., and at Wyoming, Pa., during July, 1778, exceed all others in enormity. Such fearful outrages overleaped their intent and reacted against the British.

Fifth Campaign, 1779.

Savannah.—Gen. Clinton planned to subjugate Georgia and the Carolinas. Tories in numbers had assembled in East Florida, Gen. Prevost commanding, and made predatory excursions into Georgia, keeping the country in alarm. To meet this, Gen. Robert Howe, Continental commander, with 500 men, moved over from Charleston to Savannah. He was soon joined by abundant volunteers and militia. An expedition toward Florida was organized and its execution was hopefully commenced, when it was broken up by the Governor of Georgia and other officers refusing to recognize Gen. Robert Howe's Continental commission. Hearing of this dissension Clinton dispatched Lieut.-Col. Campbell with 3500 soldiers and a naval accompaniment. Gen. Prevost was at the same time marching against Savannah from the south. Campbell arrived first, and on Dec. 29, 1778, gave battle. Robert Howe, receiving some accessions from Georgia and vicinity, made resistance; but the battle was of short duration. Howe escaped with a part of his command. The remainder were killed or taken prisoners, or perished in the swamps. Sunbury and Augusta were next taken, and soon Gen. Prevost held in subjection the whole of Georgia. He made one effort to make a permanent lodgment in South Carolina, but Gen. Lincoln, through Col. Moultrie using local militia at the battle of Beaufort, Feb. 3, 1779, thoroughly defeated him. The patriots under Col. Pickens, but 300 strong, had another success at Kettle Creek on Feb. 14, against Col. Boyd, who, with 700 men, was ravaging the neighborhood. Gen. Lincoln, thus encouraged, sent Gen. Ashe to recover Augusta, but Prevost surprised him at Briar Creek and nearly destroyed his command. Again Lincoln with 800 patriots, June 20, 1779, tried his fortune at Stono Ferry, where Maitland with a force of 1200 men was threatening Charleston. Lincoln was repulsed with considerable loss.

Admiral d'Estaing, returning from the West Indies with his fleet, joined Lincoln in an attempt to recover Savannah. After the failure of the assault, Oct. 9, 1779, d'Estaing left for France.

In December of 1778 Washington's army was occupying winter quarters. Gen. Putnam commanded a portion at Danbury, Conn.; Gen. McDougal detachments and forts in the Highlands, and a small army with head-quarters at Middlebrook, N. J. Early in 1779 Sir Henry Clinton undertook but little, except the sending from his own vicinity predatory and foraging expeditions; and therefore Washington continued mainly on the defensive. In July, however, he sent Wayne to recapture Stony Point, then garrisoned by 600 soldiers under Lieut.-Col. Johnson. Wayne attacked at midnight, his followers rushing in two columns from different sides without firing a shot till in possession. Wayne secured the entire garrison with a loss of but 98 men. It was denominated "the most brilliant assault known."

On Aug. 19 Major Harry Lee surprised Paulus Hook, near New York, and captured 150 of the garrison. Gen. Sullivan, during the same month, had extraordinary success in almost annihilating a force of Tories and Indians who were led by the fierce Gen. Brant in "the battle of Chemung."

The incipient patriot navy did something. Paul Jones gained historic renown, commanding a few American and French vessels, by boldly attacking two British frigates on the English coast. Both captured, September 23, at 10 P. M.

Sixth Campaign, 1780.

Thus far Sir Henry Clinton had almost undisputed success in the South. He naturally began operations there for 1780. With a good naval force, under Com. Arbuthnot, escorting 7500 troops of the line, Clinton appeared before Charleston about April 1 and commenced a siege. Gen. Lincoln, with some 600 patriots, made a prolonged defence. Col. Huger covered his communications at Monk's Corner with about 300 more. The terrible Gen. Tarleton, with 800 men, fell upon this guard April 14, dispersed it, and so held Lincoln's rear. At last, May 12, 1780, the gallant but unfortunate Lincoln surrendered his entire army.

Sir Henry followed up his victory by expeditions into the interior. Fort 96 was captured. Tarleton surprised Col. Buford's 300 Virginians at Waxhaw and "massacred or maimed every man." Now believing South Carolina subjugated, Clinton, leaving Cornwallis to replace him, returned to New York. The patriots Sumter and Marion were not yet conquered. They would suddenly gather their clans and clouds of battle would seem to burst from a clear sky. Rocky Mount was garrisoned by about 500 New York and South Carolina Tory volunteers, commanded by Lieut.-Col. Turnbull. Sumter, with 600 patriots, assaulted the works with impetuosity several times, but could not carry them; yet a little later, at Hanging Rock, he was victorious over Col. Brown and a similar garrison. Lord Cornwallis had come out as far as Camden, S. C., with 2200 men. Gen. Gates, replacing Lincoln, had gathered 3000 effectives. He and Cornwallis had both determined to attack at daylight, August 16, and each began a night march. They met about 2.30 A. M., skirmishing till dawn and then engaged. Gates was completely out-generalled and his army almost destroyed. Sumter, two days after, was surprised by Tarleton, and of his 700 followers only about 200 escaped death and capture. But already a change had come. One of the most active of the royal officers was Major Patrick Ferguson, 71st Regulars. He had with him at King's Mountain, N. C., 900 soldiers. The patriots of Virginia and North Carolina had run together, hoping to assist Gen. Gates; 1100 under Cols. William Campbell, Cleveland, and Williams had asked for a general officer, but Col. Campbell had charge till his arrival. On the morning of October 7 they rushed upon Ferguson's position, slew him, and completely routed his force.

Seventh Campaign, 1781.

Gen. Greene's Operations in the Carolinas.—Early in January, 1781, Gen. Greene, who relieved Gen. Gates of his command, arrived on the borders of North Carolina. He at once reorganized; the patriots flocked to his standard, and he began to control the partisan leaders. He first sent a detachment of 900 under Gen. Morgan into South Carolina to check depredations. The ubiquitous Tarleton overtook him at Cowpens, and the engagement was a sharp one, but resulted in a thorough victory for Morgan and a loss to Tarleton of over 800 men. To get clear of Cornwallis' pursuit, Morgan retreated till he had joined Gen. Greene in North Carolina. The celerity of Greene and heavy storms coming in quick succession kept Cornwallis at bay till the patriot army was sufficiently reinforced to risk a battle.

At Guilford Court-House Gen. Greene took position with about 4000 men. Cornwallis made an attack March 15, and finally, after a close contest, dislodged and defeated the patriots; yet he suffered so great a loss himself and was so far from his base, that he began to retreat on the 18th, and bore away towards Wilmington, N. C., leaving Lord Rawdon to command what he left behind in South Carolina, a field-force of about 1200. Taking advantage of the division of forces, Gen. Greene pushed off in the direction of Camden, S. C. On April 25 another battle, almost

a surprise to Greene, occurred at Hobkirk Hill. It was only a partial engagement, at the end of which Greene was compelled to retreat. There was but one more important engagement in South Carolina, and that was the well-known battle of Eutaw Springs, where Gen. Greene brought to bear 2000 patriots against 2800 British, mostly regulars, under Lieut.-Col. Stewart. This time Gen. Greene gained a signal victory. His own losses were heavy, but he inflicted a greater, and caused Stewart's rapid flight to Charleston.

Siege of Yorktown.—Arnold, after his attempt to betray and surrender West Point, had fled to the British and been made a brigadier-general in the English army. Before his desperate raid into Connecticut he was sent in charge of a predatory expedition up the Peninsula as far as Richmond, Va. Another British general, Phillips, was also moving to subjugate the belligerent Virginians. To form junction with these forces and keep open their communications with the sea, Lord Cornwallis marched from Wilmington into the lower counties of the State. Washington, knowing of the troubles there, had sent Gen. Lafayette with a small army to watch the raiders and do all that he could to hinder them. Early in May the French minister brought the welcome information that another French fleet, under the command of the Count de Grasse, bringing reinforcements, would soon arrive. A little later, Washington and the Count de Rochambeau, the field commander, met at Wethersfield and arranged for an allied and combined movement against the city of New York. But learning that de Grasse could not stay long, and that he was going directly to the Chesapeake, Washington at once changed his plan, resolving and arranging to move against Cornwallis in Virginia.

He executed this movement with wonderful caution: kept Sir Henry Clinton deceived as to his intentions till all his divisions except Gen. Heath's, which was left to threaten New York, were well across the Delaware and the French fleet between Yorktown and the sea blocking the way. Lord Cornwallis was already at Yorktown with his main body, where, in view of the threatening dangers, he was thoroughly fortifying both banks of the York River.

Washington speedily assembled his army at Williamsburg, and on Sept. 28, 1781, marched it to Yorktown and distributed his troops for a siege. The American forces, resting on the river below the town, deployed so as to occupy the right, the French so as to hold the left, the two meeting at a central morass. On the east, or Gloucester, side of the river, Sieur de Choisey, with a detachment, completed the land investment. Cornwallis had in the aggregate, besides his fleet, 7500 men. Washington, beyond his naval help, had gathered, including the French contingent, about 16,000. Sir Henry Clinton first endeavored to turn Washington back by diversions. He sent Arnold, recalled from Virginia, to lead a cruel expedition against New London, Conn. This failing, he encouraged Cornwallis with the hope of relief by raising the blockade and introducing troops and supplies. But at last, after a closer investment was effected and the impossibility of succor became evident, the proud Cornwallis, on Oct. 19, 1781, surrendered Yorktown and his entire army to Gen. Washington, and his shipping, with all the seamen, to the Count de Grasse.

Though the British held New York and other cities already in their possession till the establishment of peace, this surrender substantially closed the war. Negotiations were soon begun, a truce entered into, and a preliminary treaty effected and signed the 30th of November, 1782. The permanent treaty, with full specifications, was completed and signed at Paris, France, Sept. 3, 1783. (O. O. H.)

REYBAUD, MARIE ROCH LOUIS (1799-1879), French author, was born at Marseilles, Aug. 15, 1799. His father being a merchant destined him also for trade, and the son made several voyages to the Indies.

In his thirtieth year, however, he removed to Paris and began to contribute to the liberal journals. His satiric pen attacked the reign of the bourgeois under Louis Philippe. He was also director of the publication of the *Histoire Scientifique et Militaire de l'Expédition Française en Égypte* (10 vols. besides atlas, 1830-36), a work which Napoleon I. had caused to be prepared at enormous expense. Reybaud also edited the travels of Dumont d'Urville and d'Orbigny. In another direction he achieved success by his *Études sur les Réformateurs ou Socialistes Modernes* (2 vols., 1840-43), which obtained from the French Academy the Montyon prize. It discussed freely but fairly the socialistic schemes of St. Simon, Fourier, Robert Owen, and Cabet; but in later years the author expressed regret that he had not severely denounced "those destroyers of every social principle." In 1850, in consequence of this able work, Reybaud was elected to the Academy of Moral and Political Science. Another work in a lighter vein long retained its popularity. This was *Jérôme Futurot à la Recherche d'une Position Sociale* (1843), in which the manners of French society were held up to ridicule. A later volume of the same kind and partly the same name, but having reference to the Republic of 1848, did not meet the same success. Still Reybaud continued to work this vein for ten or twelve years. Reybaud had been a Liberal, but the revolution of 1848 made him a Conservative. In 1846 he had been elected to the Chamber of Deputies as the representative of Marseilles. He supported Louis Napoleon as president but refused to join in the *coup d'état* of 1851. In later years he contributed to various reviews and encyclopædias on industrial, economic, commercial, and marine topics. Among his works were *L'Industrie en Europe* (1856); *Économistes Modernes* (1862); *Mœurs et Portraits du Temps* (1864). Pres. Thiers in 1872 again called him into public service for a brief period. Reybaud died Oct. 28, 1879.

REYNOLDS, JOHN (1789-1865), governor of Illinois, was born in Montgomery co., Pa., Feb. 26, 1789, of Irish parents, who during his childhood removed to Kaskaskia, Ill. In 1812 he joined a company of scouts in the campaigns against the Indians. Settling at Cahokia, Ill., he became a lawyer, and in 1818 was made a justice of the Supreme Court of the State, then just admitted to the Union. He was elected to the Legislature in 1826 and served till 1830. During the Black Hawk war, in 1832, he had command of a volunteer company. He afterwards edited a daily paper at Belleville, served again in the Legislature 1846-48, and was speaker of the house 1852-54. He died at Belleville, May 8, 1865. He was a Democrat of strong opinions and strict integrity. He published a *Pioneer History of Illinois* (1848), and a bulky volume called *My Life and Times* (1855). This work, badly printed, had but little sale, and nearly every copy was destroyed in the great fire at Chicago in 1871, but its importance as a record of facts being recognized by the Chicago Historical Society, an improved edition was issued in 1883.

REYNOLDS, JOHN FULTON (1820-1863), general, was born at Lancaster, Pa., Sept. 20, 1820. He graduated at West Point in 1841 and entered the artillery. At the outbreak of the Mexican war he joined Gen. Taylor's army, and was distinguished at Monterey and Buena Vista, winning the brevets of captain and major. He afterwards served on the frontier until 1860, when he was appointed commandant of cadets at West Point. In May, 1861, he was made lieutenant-colonel of infantry, and in August brigadier-general of volunteers. He took command of a brigade of the Pennsylvania reserve corps, and led them in McClellan's Peninsular campaign in 1862 until he was taken prisoner at Glendale, June 30. He was exchanged in August, and commanded a division in Gen. Pope's campaign in Northern Virginia. When Lee invaded Maryland, Gov. Curtin, of Pennsylvania, selected Gen. I

Reynolds to command the militia called out for defence of that State. He was soon after promoted major-general of volunteers, and the First corps of the Army of the Potomac was assigned to his command. He fought at Fredericksburg, Dec. 13, 1862, but at Chancellorsville his corps was held in reserve, though he requested to be sent to the front. When Lee invaded Pennsylvania in 1863, Reynolds, with the left wing of Meade's army, was hastening to overtake him. Encountering the van of the Confederate army at Gettysburg on July 1, he had already selected the ground for the impending battle, when at the opening of the fight he was killed by a rifle-shot, while cheering on his men. He was beloved by his soldiers and distinguished for ability as a general. A monument to his memory, designed by J. Q. A. Ward, is erected at Gettysburg; a bronze equestrian statue of him by Rogers stands in Philadelphia in front of the city hall.

RHETT, ROBERT BARNWELL (1800-1876), a noted secessionist, was born at Beaufort, S. C., Dec. 24, 1800. He was the son of James Smith, but in 1837 assumed the name Rhett from an ancestor. He was liberally educated and became a lawyer. In 1826 he was elected to the State Legislature, and in 1832 was made attorney-general. Throughout the nullification movement he was an advocate of the extreme view of States' rights. In 1838 he was elected to Congress and there maintained the same extreme position on every question affecting the South. After twelve years in the lower house he was sent to the Senate in 1850, where he openly advised a dissolution of the Union. When these views were disapproved by the people, he resigned from the Senate, but continued to urge the political doctrines of Calhoun in the *Charleston Mercury*, of which he was proprietor. In 1860 he took a prominent part in the State convention which passed the ordinance of secession. At the convention in Montgomery, Ala., he was chairman of the committee which reported the Constitution of the Confederate States. He was also a member of the Confederate Congress, and at the close of the war retired from public life. He died in St. James Parish, La., Sept. 14, 1876.

RHODE ISLAND. The smallest of the United States, it is also the most densely populated, and in the value per capita of its textile fabrics it exceeds every other. In inhabitants to the square mile only four countries of the world, viz., Belgium, British India, the Netherlands, and Great Britain, including Ireland, exceed it.

Population.—In the last census, taken in 1885, the population of the State was 304,284, an increase from 1880 of 27,888. The increase since 1885, judging by the best information that can be obtained, has been at a more rapid ratio. There has been a marked increase in the immigration of French Canadians, Swedes, and Italians.



Education and Illiteracy.—In 1887 the Legislature of the State enacted a law requiring, under a penalty not to exceed twenty dollars, that every person having under his control a child between the age of 7 and 15 shall annually cause such child to attend for at least 12 weeks, 6 at least of which shall be consecutive, some public day-school in the town or city where such child resides. To make this law effective, the same statute requires each town or city to appoint a special constable or truant officer who shall see that the law is complied with; it also requires each town and city to provide a suitable place for the confinement, discipline, and instruction of truants. The same statute forbids the employment of any child under 0 years of age "in any manufacturing, mechanical, or

mercantile establishment, or by any telegraph or telephone company" while the public schools are in session, and forbids that any child between 10 and 15 years of age shall be "so employed," except during the vacations of the schools, or under certain conditions which are minutely specified. Truant officers are also authorized to visit establishments where children are employed, and all owners, superintendents, or overseers of such establishments shall keep on file certificates duly authenticated and minutely specifying that said children have complied with the educational law. In spite, however, of these and all other provisions for the enforcement of the law, alien parents with children born before coming to the State are constantly violating it, through false statements respecting their children's ages. Illiteracy (meaning thereby inability to read and write) in the State, in 1880, was in the ratio of 11.2 to 100 of the whole population; in 1885 the percentage was 10.7. Under the operation of the compulsory law it is hoped and believed it will soon be still further reduced.

Cities.—The State now contains four incorporated cities—Woonsocket, with a population of between 16,000 and 17,000, having in 1888 been added to Providence, Newport, and Pawtucket.

Amendments to the Constitution.—Several of these have been made since 1885. According to a provision of the constitution itself, no amendment to it can be made which has not first been approved by a majority of the whole General Assembly (consisting of a House of Representatives and a Senate), and being submitted to a popular vote shall have been accepted by three-fifths of all the voters of the State. The first of the amendments referred to was made in 1886, prohibiting the manufacture and sale of intoxicating liquors to be used as a beverage. In the May session of the same year the General Assembly (which holds two sessions a year, the first in May, at Newport; the second beginning in January, at Providence), passed a long series of enactments for the enforcement of prohibition. Some of the enactments, and especially some of the officials appointed to carry the enactments into execution, gave great offence to large numbers of citizens of both political parties. The enactments and appointments known as the "May deal" resulted at the next State election in a complete overthrow of the Republican party, under whose administration the "deal" took place. The practical result was, that the prohibitory law became a dead letter, and intoxicating liquors were for sale openly and anywhere. During the present year, 1889, the Republicans are again in power, and the office of attorney-general is filled by an officer who is prosecuting offenders against the law with a vigor and determination that bids fair to secure for it some show of respect.

At the May session of the Legislature in 1888 an amendment was submitted to the people extending the suffrage to all soldiers and sailors of foreign birth from Rhode Island who served in the army or navy of the United States during the late civil war, and, receiving the requisite three-fifths of all the votes cast, it became a part of the Constitution.

A proposed amendment in 1887, extending the suffrage to women, was submitted to the electors, but failed to receive the required three-fifths of the votes polled.

At the January, 1888, session of the General Assembly an amendment was approved and submitted to the electors, extending the suffrage to every male citizen of the United States who had for two years been a resident of the State and for six months a resident in the town or city in which he may offer to vote, and who has been duly registered; provided, however, that he shall not be allowed to vote in the election of the city council of any city, or for the imposition of any tax, or for the expenditure of any money, unless he shall during the immediately preceding year have paid a tax on property assessed at a valuation of not less than

\$134. The assessors of each town or city shall impose on each registered voter a tax of one dollar, "or such sum as with his other taxes shall amount to one dollar," and said tax shall be paid into the public treasury for the support of public schools, the General Assembly, however, retaining to itself the right to prescribe by law for the remission of this tax under given conditions. This amendment received the required three-fifths vote at the general State elections in April, 1888.

Industrial Progress.—No satisfactory information on this point is at present obtainable. The discrepancies between the State census of 1880 and that of 1885 are so great and of such kind as to show that neither one of them can be relied on for exact information. For example, in 1880 the capital invested in cotton manufacture was said to be \$29,260,734, and in 1885 it was \$21,154,255, whereas it is well known that there has been a large increase in the capital so invested. In woollen manufactures the capital invested was reported in 1880 as \$13,016,116, and in 1885 as \$8,568,450, whereas there are good reasons for believing that there could have been only a fractional difference, if any, in the two periods. In 1880 the total value of the products of the State was put at \$108,714,671, and in 1885 at \$104,269,773; the product to each person being in the first \$393.14, and in the second \$342.67. And so on throughout the two censuses. The only explanation given of these differences is, that in 1880 the estimates of value were made by the census-takers, and in 1885 the estimates given were those of the manufacturers themselves. It is the estimate of good judges that the annual increase in the value of the products for the past few years has not been less than five per cent. and probably has been more. (E. G. R.)

RHODODENDRON, a genus of shrubs or small trees of the *Ericaceae*, or heath family, which, including the Azaleas, comprises the handsomest and most showy flowering shrubs of both hemispheres. The species of the genus are widely distributed, America possessing several, the blossoms of some of which are unsurpassed for beauty among our wild flowers. These are locally known as Rosebay trees, but more generally by their scientific title of Rhododendron (Greek, *rhodon*, rose; *dendron*, tree; from the rose-colored flowers of many plants of the genus). *R. maximum*, the common American species, is an arborescent plant, bearing pale-red, funnel-shaped, wide-mouthed flowers in umbellate corymbs, studded with green, yellow, or purple protuberances, the leaves of elongated oval



Rhododendron.

form, smooth, and of thick coriaceous texture, their length being 5 or 6 ins. The plant varies from about 10 ft. to 20 or 25 ft. in extreme height, and 4 or 5 ins. diameter. It is an evergreen, renewing its leaves every 3 or 4 years, and flowering from June to

August. The flowers, though ordinarily rose-colored, are sometimes pure white, and always occur at the extremities of the branches in beautiful groups which derive an added charm from the luxuriant foliage which surrounds them. The seeds are exceedingly minute, and are contained in capsules which open in autumn for their escape. This species occurs sparingly from Long Island northward along the Hudson to the Highlands, but is rarely found as far north as Massachusetts. It is very common in the mountain districts of the Middle and Southern States, particularly those of Georgia and the Carolinas, and is found almost exclusively on the borders of streams, growing so abundantly on the sides of the mountain torrents of the Alleghenies as sometimes to form impenetrable thickets. It prefers deeply shaded situations, near cool waters, where the atmosphere is full of moisture. The wood is hard, compact, and fine-grained, but too small to be of much use in the arts, and the almost entire use of the Rhododendron is as an ornamental plant. A variety of the species, *R. m. purpureum*, the purple-flowered rosebay tree, a native of Virginia and the Carolinas, bears large purple flowers, and grows to a height of 25 ft., with a stem occasionally as much as 18 ins. diameter.

A second important American species, *R. Catawbiense*, is a shrub from 3 to 6 ft. high, its flowers broadly bell-shaped, and of lilac-purple hue. It is found on the higher Alleghenies from Virginia to Georgia. Of species of less importance may be named *R. Lapponeum*, the Lapland Rhododendron, a dwarf species belonging to the Arctic flora of both continents; *R. punctatum*, a small species with rose-colored flowers, on the mountains of North Carolina and southward; and *R. albiflorum*, a Rocky Mountain species, with drooping, cream-colored flowers. *R. Californicum* is a plant of moderate size with very showy rose-colored flowers.

The Rhododendrons have for many years been cultivated as garden flowers, particularly in England and Europe, very many highly beautiful varieties having been produced. No other shrubs equal them for beauty of form and foliage and profusion and variety of flowers, while they are very manageable and not easily injured. Their cultivation in this country is rapidly on the increase, the principal incentive to it having been a magnificent English display made at the Philadelphia Centennial Exhibition. *R. Ponticum*, an Asiatic species, is the basis of most of the cultivated varieties, but it and other delicate Eastern species have been largely hybridized with the hardy *R. Catawbiense*, greatly to their improvement in beauty and vigor. From this hybridization has arisen most of the fine ornamental forms now so extensively cultivated. *R. Maximum* has proved less adapted to the production of useful hybrids.

The leaves of some species of Rhododendron are said to be poisonous to cattle, yet they have been used in moderate doses as remedies for rheumatism. This poisonous quality is said to pertain to the nectar of the flowers of *R. Ponticum*. In India the natives eat the flowers of *R. arboreum*, and the English prepare a conserve from them. The leaves of *R. campanulatum* are powdered and used as snuff by the natives. Some American Indians are said to employ the dust which adheres to the petioles of *Kalmias* and Rhododendrons for a similar purpose. (C. M.)

RHUBARB. The root and leaf stalk of several species of the genus *Rheum*, order See Vol. XX. *Polygonaceæ*, the root being used as a valuable medicine, and the leaf stalk as an article of food. All the species of *Rheum* have purgative and astringent properties, this being particularly the case with the roots. It is not certain which species yield the commercial rhubarb, as they grow in regions of Thibet or Western China which have not been explored by naturalists. It has been known as a drug from a remote period,

being long brought to the ports of the Levant, and thence shipped, whence the name of Turkish Rhubarb was given to the best qualities. It is now shipped directly from China. Rhubarb has a peculiar smell, and a disagreeable, bitter, astringent taste. In small doses it acts as a stomach-bitter, but in large ones as an active purgative. Numerous pharmaceutical preparations of it are in use.

Several species, including *R. Rhaponticum*, *R. Tartarium*, *R. undulatum*, and others, all of Asiatic origin, are now largely cultivated for culinary purposes, their acidulous leaf stalks and unexpanded flower mass being largely used under the common name of Pie Plant. These stalks are from 1 to 3 ft. long and 2 to 3 ins. in diameter in their widest part, of a pale-green color often tinged with red, and are very succulent, with a pleasantly acid taste. They are used as a substitute for fruit in pies, tarts, etc., while the expressed juice forms a palatable wine. Rhubarb has been used for this purpose only since 1800. It is now largely raised by market gardeners, the annual crop being very considerable. It succeeds best in deep and somewhat retentive soil, the richer its condition and the deeper worked the better. It may be propagated by seeds or by division of the roots, the latter being the usual method. It is not usually plucked till the third year, but a plantation not too greatly cut will bear from ten to fifteen years. It lends itself well to the forcing process, and this is practised extensively by gardeners for early supply of the market. (C. M.)

RIBBECK, JOHANN KARL OTTO, a German philologist, was born July 23, 1827, at Erfurt. He was educated at Breslau, Berlin, and Bonn, enjoying at the last the instruction of F. W. Ritschl, with whom he held a life-long intimacy. In 1852 he visited Italy and was afterwards engaged in teaching at Berlin and Elberfeld. In 1856 he was made professor extraordinary in the University of Berne, and in 1859 was advanced to a full professorship, with the direction of a philological seminary which he had himself founded. In 1862 he was made professor in the University at Kiel, in 1872 at Heidelberg, and in 1877 succeeded Ritschl at Leipsic. Ribbeck's chief works are *Scenice Romanorum poesis Fragmenta* (2 vols., 1852-53); *Die Römische Tragödie im Zeitalter der Republik* (1875); his critical edition of Virgil with its *Appendix* (5 vols., 1859-68), his labors on Juvenal and Horace. He also published a memoir of his friend Ritschl (2 vols., 1879-81).

RICASOLI, BARON BETTINO (1809-1880), an Italian statesman, was born at Florence, March 9, 1809. In March, 1847, with some companions he addressed two memorials to the Tuscan government demanding a constitution and a free press. During the revolution following, Ricasoli established *La Patria*. He was then chosen *gonfaloniere* or mayor of Florence, and in the next year entered the Tuscan Parliament. After the battle of Novara he favored the recall of the Grand Duke in the hope of effectual resistance to the Austrian domination. But he was disappointed, and soon abandoning political activity he devoted his energy to the improvement of a newly purchased estate in the Maremma. He was induced some years later to place himself at the head of the National party, and was the chief founder of the *Biblioteca civile dell'Italiano*. In 1859 the Grand Duke fled and Ricasoli, who was minister of the interior in the provisional government, contributed essentially to effect the union with Sardinia, which was formally declared March 22, 1860. He was then appointed governor-general of Tuscany and was also elected to the enlarged Sardinian Parliament and to the first Italian Parliament, which met in February, 1861. After the death of Cavour in June he formed a new ministry, taking for himself the department of foreign affairs. Though he was faithful to Cavour's policy he could not command his followers and in March, 1862, he retired. He was still the representa-

tive of Florence in the Parliament, and in 1866 he was again premier and minister of the interior, though only for ten months. He died in his castle Brolio near Sienna, Oct. 23, 1880.

RICE is the common name of *Oryza sativa*, a plant of the order Gramineae or grasses, the seed of which is more widely used as an article of nutriment than that of any other cereal. The plant has been known and cultivated for ages, particularly in Eastern Asia. Its generic title, *Oryza*, used by Theophrastus, and the Arabic *aruz* are not far from the modern European *riz*, *reis*, or *rice*. The rice plant is an annual, with a stem from one to six feet high, its leaves lanceolate, and flowers borne in a terminal panicle. In Asia two distinct species of *Oryza* are cultivated, the lowland and the upland rice, of which the latter rots if inundated and perishes in sea water. The lowland rice, which is the species cultivated throughout the world, bears more extensive inundation than almost any other food plant, though it can be grown without inundation, and is the basis of both the lowland and upland rice of the United States. The rice plant furnishes more food to mankind than any other grain, as it constitutes the principal food supply of the teeming millions of India and China, while largely used in other parts of the world. It is the grain of the intertropical regions, as wheat is of the temperate and oats and rye of the more northerly latitudes. It is produced in immense quantities in most countries of Eastern Asia, in some of the southern countries of Europe, in parts of the West Indies, Central America, and the United States, and supplies perhaps one-third of the human race with its main article of food. Fifty or more varieties of the plant are cultivated in different countries, the principal differences being in the size, shape, and color of the grain, but these practically resolve themselves into lowland or aquatic rice and upland or mountain rice. As regards the extent and methods of the cultivation of rice in Japan, China, and India, see U. S. *Consular Reports*, No. 96, August, 1888.

As an article of nutriment rice falls below wheat, containing less than half the amount of the gluten. It has one-fourth more starch, however, and this, with its cheapness and large yield, renders it a preferable basis for starch manufacture.

The culture of rice in the United States began in 1694, in which year a vessel from Madagascar, which put into Charleston in distress, had on board a small sack of rice, which was given to the authorities of the city, and was at once tried in garden culture. It yielded abundantly, and the seeds were distributed to planters, which process was continued until it became the staple commodity of the colony. From South Carolina its culture extended through other Southern States, it being now raised extensively in Georgia and Louisiana. It possessed the advantage that it could be profitably grown on land too low and moist for other useful plants, and that its culture required less labor than the other grains. The swamp lands along the South Carolina coast proved well adapted for its culture, and yielded excellent returns, but are now replaced in considerable part by the irrigation of tide lands, which present decided advantages in the culture. American rice has long borne a high reputation for its excellence, its quality being far beyond that of any other locality. This is perhaps partly due to favoring conditions of soil, but largely to care in cultivation, the grain being much sweeter, larger, and better colored than that from Asia, the Bengal rice most nearly approaching it.

The culture of rice in Louisiana was begun in 1718, by Law's French "Company of the West." Recently its production there has greatly increased, the levees along the Mississippi being opened by permission for irrigation of the fields in the adjoining alluvial bottoms. The principal expense there is the ditching and other-

wise preparing the land for irrigation, the seeding and cultivation being comparatively inexpensive. The process pursued is briefly as follows: The sowing being completed, the river water is let on profusely, and kept so until the growing plant appears above its surface. Then the field is drained, and kept dry until the stem begins to form joints, when it is flooded again and left so for about six weeks, till the grain is mature. During this period it is simply necessary to see that the water is kept fresh, and to pull up such weeds as the water fails to kill. Maturity is indicated by the grain turning yellow. The field is then drained, the grain cut, threshed, and winnowed, and sacked for mill or market. An expensive process, however, is necessary to get rid of the inner hull of the rice grain, which it holds more tenaciously than wheat. Special machines are needed for this purpose, in which the grain is so broken that after milling little more than half remains prime rice, the remainder being partly broken rice, partly flour. The upland rice yields a smaller grain than the lowland, though with the advantage of being harder and drier. It is cultivated much like the other small grains, the crops being remunerative, though smaller than that of lowland rice. One disadvantage of the rice culture on the Atlantic is that it proves very detrimental to the health of white men, from the dangerous malarial exhalations from the irrigated soil. The negroes, however, are rarely affected by malaria. The Louisiana culture seems no more injurious to health than in the case of any other crop raised there.

The rice crop of the United States has suffered considerable fluctuations during the several recent decades, as appears by the following statement:

Year.	Crop.
1840.....	80,841,422 pounds.
1850.....	215,312,710 "
1860.....	187,140,173 "
1870.....	73,635,021 "
1880.....	110,131,373 "

The decrease in production is made up by a very considerable importation. During this period the production of South Carolina has decreased, and that of other States advanced, that State producing, in 1850, 159,930,613 lbs., and in 1880, 52,077,515 lbs., while Georgia and Louisiana have correspondingly increased. At present rice is cultivated from near the Southern Virginia line to Texas, and well back from the coast lands into the upper country. In 1880, according to the census reports, 174,173 acres were under cultivation for rice, with the following yield in the four principal States:

	Acres.	Product.
South Carolina.....	78,388	52,077,515 pounds.
Georgia.....	34,973	25,369,687 "
Louisiana.....	42,000	23,188,311 "
North Carolina.....	10,846	5,609,191 "

In Asia rice is used to a considerable extent in the making of intoxicating drinks, a rice beer or "sake," being extensively used in Japan, while a strong spirit, called "arraek," is distilled from rice and molasses, and used throughout the East Indies. Rice sugar yields in Japan a kind of confectionery called "ame." Enormous quantities of rice are now consumed in the manufacture of starch particularly in Great Britain.

(C. M.)

RICE. LUTHER (1783-1836), the organizer of American Baptist missions, was born at Northborough, Mass., March 25, 1783. After graduating at Williams College in 1810, he entered Andover Theological Seminary, and there joined in the movement already begun by Samuel J. Mills in advocacy of missions to the heathen. He was ordained with Judson, Newell, and two others at Salem, in February, 1812, and sailed to India. But on the voyage, from fresh study of the New Testament, he adopted Baptist views and was baptized soon after his arrival in Cal-

cutta. As Judson, who had sailed in another vessel, had experienced a similar change of views, it was arranged that he should stay for mission labor in India, while Rice returned to seek support for the work from the Baptist denomination. His return excited a sensation among religious people, and at the General Convention in 1814 a Baptist Missionary Society was formed, of which Rice was made the agent to visit the American churches. After several years thus spent, Rice projected the Columbian College at Washington, and devoted himself to similar labors in its behalf. He died in Edgefield, S. C., Oct. 25, 1836.

RICE, NATHAN LEWIS (1807-1877), Presbyterian theologian, was born in Garrard co., Ky., Dec. 29, 1807. He graduated at Centre College, Danville, and was ordained pastor of a Presbyterian church at Bardstow, Ky., in 1833. He was pastor in Cincinnati from 1844 to 1853, and during this time conducted public controversies with Rev. Alex. Campbell on baptism, with Bishop Purcell on Roman Catholicism, and with others. In 1853 he removed to St. Louis, and in 1858 to Chicago, where he became professor in the Theological Seminary of the North-west. In 1868 he was made president of Westminster College, Mo., and afterwards became professor in the Danville Theological Seminary. He died at Danville, June 11, 1877. He was an able preacher and conservative theologian. His writings were chiefly controversial.

RICHARDS, WILLIAM (1792-1847), missionary, was born at Plainfield, Mass., Aug. 22, 1792. He graduated at Williams College in 1819, studied theology and was sent by the American Board of Commissioners for Foreign Missions to the Sandwich Islands in 1822. There he gave instruction to the royal family, and in 1838 was made counsellor and chaplain to King Kamehameha III. After the Sandwich Islands were recognized as an independent nation by England and other powers, Richards was sent on an embassy to them. In 1845 he was appointed minister of public instruction. He died at Honolulu, Dec. 7, 1847.

RICHARDSON, BENJAMIN WARD, English physician, was born at Somerly, Leicestershire, Oct. 31, 1828. He was educated at Glasgow and graduated in medicine at the University of St. Andrew's in 1854, gaining there a gold medal for an essay on ante-natal diseases. In 1856 he won the Astley Cooper prize for an essay on coagulation of the blood. He then became a member of the Royal College of Physicians and was elected a fellow of the college in 1867 and Croonian lecturer in 1873. He has made special experiments in regard to the poison of contagious diseases, anaesthetics, restoration to life after apparent death, methods of killing without pain animals intended for food. His best known researches, however, have been in regard to the action of alcohol on man. He has received many marks of honor from learned and scientific societies and colleges, including the degree of LL.D. from St. Andrew's University in 1877. His medical brethren presented him in 1868 with a microscope and 1000 guineas in recognition of his contributions to science and medicine.

RICHARDSON, CHARLES (1775-1865), English lexicographer, was born in July, 1775. He studied law but devoted himself to literature. After publishing *Illustrations of English Philology* (1815) he undertook to prepare for the *Encyclopaedia Metropolitana* articles on lexicography. These served as an introduction to his *Dictionary of the English Language* (2 vols., 1837), whose peculiarity is that derivative words are classified under their primitives and abundantly illustrated by quotations. The *Dictionary* proved popular, passed through several editions in England and was reprinted in the United States. Richardson continued his philological labors, publishing a *Supplement* (1855), a *Historical Essay in English Grammar* (1845), and a work on *The Study of Languages* (1854). He also published some comments on Shakespeare and contrib-

uted to various literary periodicals. He died at Feltham, Middlesex, Oct. 6, 1865.

RICHARDSON, HENRY HOBSON (1838-1886), architect, was born at Priestley's Point, La., Sept. 29, 1838. His father was a planter of Scotch descent and his mother a daughter of Dr. Joseph Priestley (for whom see *ENCYCLOPÆDIA BRITANNICA*). After graduating at Harvard in 1859, Richardson went to Paris to study architecture. The loss of his property through the civil war compelled him also to exert himself for his own support. Returning to the United States in 1865, he engaged at once in his chosen pursuit and formed a partnership in New York city. The city of Springfield, Mass., was the first field for the display of his powers; there he erected railroad offices, a bank and a church, which gave promise of better work to come. In 1871 his Brattle Street Church, Boston, first strikingly exhibited his originality of design and marked an advance toward his grander Trinity Church in the Back Bay section of the same city. The leading idea of this building, the tower which dominates both its exterior and interior, was derived from the churches of Auvergne. To the decoration of the interior the artist La Farge contributed excellent work. During the erection of this church Richardson removed to Brookline near Boston, and his reputation being firmly established was thenceforth busily occupied with structures for every variety of purpose, warehouses, dwellings, libraries, churches, college and public buildings. All his works are marked by a grand simplicity of design and produce their impressive effect by massiveness rather than elaborate detail. Richardson's artistic sense was not satisfied until he gave each building an individuality characteristic of its intended object. The grand solidity and broad unity of his works set them widely apart from older American architecture. Soon a number of younger architects took him as their master and inspirer, and in all parts of the country his influence is manifest in the new edifices. The State Capitol at Albany, commenced by others, called forth his labor and skill. At the time of his death he was engaged on two important buildings, one for the Board of Trade at Cincinnati, the other the county court-house at Pittsburg. Yet amid his abundant work he had a prolonged struggle with ill health. He died at Brookline, April 28, 1886. For a fuller account of the genius which in a brief life did much for American architecture see Mrs. Schuyler Van Rensselaer's *Life and Works of H. H. Richardson* (1888).

RICHMOND, a city of Indiana, the county-seat of Wayne co., is on the East Fork of Whitewater River, 70 miles N. W. of Cincinnati, at the intersection of several railroads. It has a court-house, 3 national banks, 15 churches, a high-school and other schools, a public library, 4 daily and 4 weekly newspapers. Richmond is a settlement of the Society of Friends, whose Indiana Yearly Meeting is held here. Earlham College, founded by them in 1859, is open to pupils of either sex. Richmond has manufactures of agricultural implements, steam-engines, boilers, flour, etc. In 1880 it had a population of 12,742.

RICHMOND, the capital of Virginia, and county-seat of Henrico co., is on the N. bank of the James River, at the head of tide water, 37° 32' N. lat., 77° 28' W. long. Vessels drawing 14 feet of water can come up to Am. Rep.). Rocketts, at the lower end of the city. Bridges connect Richmond with Manchester on the south side of the James and with Belle Isle. Richmond is 100 miles nearly due south from Washington, but 116 miles by rail. It is built on a group of hills; the historic capitol, erected in 1796, and noted for its monuments, archives, and portraits, occupies the summit of Shockoe Hill. Other public buildings are the custom-house, governor's mansion, State penitentiary, post-office, city-hall, almshouse, and market-houses. There are 4 national and 8 other banks, 60 churches,

orphan asylums, and church homes. Besides the public schools, there are several educational institutions, among them Richmond College and Virginia Medical College. The falls of the James River furnish immense water-power which is abundantly utilized. There are over 600 manufacturing establishments, including iron-works, flour-mills, paper-mills, fertilizer-works, and tobacco-factories. The Tredegar iron-works are the largest and were of historic note in the civil war. The formerly extensive trade of the city was interrupted and dispersed by the war, but it has since revived and is facilitated by flour, tobacco, and other exchanges. Besides its railroad connections with North, South, and South-west, Richmond has regular lines of steamers to New York, Philadelphia, and Baltimore. Richmond was founded in 1737 by Col. William Byrd. It was incorporated in 1742, and was made the capital of Virginia in 1779. It became a political and commercial centre for the Southern States. When Virginia passed its ordinance of secession in May, 1861, the capital of the Confederate States was fixed at Richmond, which thus became the objective point of the principal military operations of the Union army in the East. It was however strongly fortified with earth-works and bravely defended, so that it resisted the various attacks until April, 1865, when it was evacuated and partly destroyed by the Confederates. For Gen. McClellan's expedition against it in 1862, see PENINSULAR CAMPAIGN, and for Gen. Grant's operations, 1864-5, see the following article.

RICHMOND, GRANT'S SIEGE OF. For the preliminaries of the series of military events in the American civil war comprised under this title, the reader is referred to the articles WILDERNESS CAMPAIGN and COLD HARBOR, which detail the preceding events from the time that Gen. Grant took command of the Army of the Potomac. In the spring of 1864 Gen. B. F. Butler moved up the James River, at the same time that Grant crossed the Rapidan. On May 6 he landed at City Point and Bermuda Hundred, and sent a force to capture Petersburg, but this was turned back by a report that that town was strongly defended. Earthworks were then thrown up at Bermuda Hundred, extending from the James to the Appomattox, a distance of 3 miles. Some fighting took place subsequently, and Butler felt himself obliged to remain in his intrenchments until called to reinforce Grant on his approach to Richmond.

After the battle of Cold Harbor, June 3, 1864, Grant having failed in his effort to capture or disperse Lee's army, and lost very heavily in doing so, decided to replace battle by siege, and to endeavor to wear out that army which he had not succeeded in vanquishing. His new plan was to transfer his army to the south side of the James, and to endeavor to compel the surrender of Lee's army by cutting off its communications, if it could not be vanquished by direct assault. This purpose was skillfully concealed, and Grant was already crossing the river while Lee was awaiting attack within the fortifications of Richmond. On the night of June 14 a pontoon bridge was thrown across the James, over which the whole army had crossed by noon of the 16th. White House, on the Pamunkey, was abandoned as a base of supplies, and replaced by City Point, on the James River, then defended by Butler's works at Bermuda Hundred.

The capture of Petersburg was an important part of Grant's design, as the possession of that city would give him immediate control of two of the railroads leading to Richmond. Butler endeavored to take it by a combined infantry and cavalry attack on June 10, but Gillmore, who was at the head of the infantry, halted when in front of the works, and fell back under the impression that his force was too weak to take them. Kautz, with the cavalry, meanwhile dashed into the town, but was driven back by its defenders, whom Gillmore's retreat had left free to act against him. Thus, by lack of proper co-operation, this prom-

ising effort failed. It was renewed five days afterward. By Grant's order Gen. W. F. Smith and his command crossed the Appomattox to co-operate with Gillmore and Kautz in a second attack on Petersburg. There was good reason to expect success from this movement, but it failed like the former, and from the same lack of activity and vigor. The troops marched in three columns, Kautz on the left, Brooks in the centre, and Martindale on the right. A negro brigade under Gen. Hinks captured some advanced rifle-pits, and the troops moved forward with assurance of success, until checked by a strong line of works in their front, apparently well defended.

Despite the formidable show of these works their defenders were really very few, and a vigorous push would probably have carried them without difficulty, but Smith paused and prepared so carefully for the assault that it was near sunset before he was ready. Meanwhile Lee's army was rapidly crossing the James, and troops were streaming down towards Petersburg. The assault took place at 7 P.M. A part of the force pushed the enemy from their line of rifle-pits, and soon had possession of the entrenchments for a length of 2½ miles, having taken 15 guns and 300 prisoners. Two divisions of Hancock's corps had now come up and joined Smith's command, when the latter ordered a halt. He deemed it wiser to hold what he had than to lose all by attempting more. Yet as Grant afterwards said, Petersburg was, at that moment, at his mercy, there being no other works and no troops of importance. By morning, however, the situation had decidedly changed. The city was then full of Lee's veterans, a new line of works had risen as if by magic, and the coveted prize was lost. The important point, which might have been taken that night in an hour or two, was destined to defy its foes during a siege of ten months' duration, in great part devoted to the capture of the two railroads which ran through the city of Petersburg.

Both armies now being south of the James, and once more confronting each other, a bombardment of the Confederate lines began, which was kept up during the whole night of the 16th. The Union lines made a general advance, and captured some important positions, though at severe loss. The battle continued throughout the 17th, the Confederates regaining some points, but failing to retake others. On the 18th an advance in force on the Petersburg works was ordered, Grant believing that only a portion of Lee's army was yet upon his front. But morning revealed the fact that the Confederates had abandoned their weakened line and retired to a stronger position on an inner line, defended by strongly constructed works. This change delayed the attack till afternoon, and then it only brought disaster to the assailants, who were repulsed at every point. In these three days of battle nearly 10,000 men had been lost, and nothing of correlative importance had been gained. It was evident now that Lee's army was fully before him, and Grant prepared for a siege of the works which he had failed to take by storm.

The next day or two were spent by both armies in intrenching, the beginning being made of those formidable works which for months defied capture from either side. At the same time the Union left was extended towards the Petersburg and Weldon Railroad, being the preliminary step towards breaking Lee's communications with the south. On the 21st the Second and Sixth corps were put in motion towards the left, but on the following morning a division of the Confederate Gen. A. P. Hill's corps projected itself between the two commands, struck Birney's divisions heavily on the flank, and drove them back with heavy loss. A similar attack was made on Wright's corps. They soon reformed, and by order of Meade advanced and retook their ground, Hill retiring with 2500 prisoners, the fruits of his impetuous assault. The advance was resumed the next morning, and the Weldon road

reached, but while the regiments in the van were engaged in tearing up the track, a sudden attack from a part of Hill's corps drove them back, many of them being taken prisoners. The railroad had been reached but had not been held, while the army had suffered a loss of nearly 4000 men, mostly prisoners.

At the same time a cavalry expedition, 8000 strong, was sent for the purpose of breaking up the railroads leading southward. They did considerable destruction to the roads, tearing the rails up for miles, but on their return found the country full of enemies, and had to fight their way back. Reaching Reams' Station on the Weldon road, which they expected to find in the hands of friends, they discovered it to be occupied by a strong force of Confederate cavalry and infantry, and were defeated with heavy loss in attempting to break through this line. They finally reached the army, but had been so severely handled that no similar raid was attempted for months. The profit proved too little for the peril and expense.

This southward movement was followed by a similar one on the north. Butler, on July 10, throwing a brigade across the James River at Deep Bottom, where an entrenched camp was formed. This post was connected with the army at Bermuda Hundred by a pontoon bridge, and was of advantage in enabling Grant to throw heavy masses to the north of the James, if desirable. Lee laid a similar bridge across the river at Drewry's Bluff, by which counter motions could be made.

And now the use of musket and cannon, and destruction of hosts of men, which had continued almost uninterruptedly for nearly two months, was replaced by the use of the pick and shovel. Several months more were busily employed in erecting those long and formidable lines of earthworks which eventually extended for nearly 40 miles, from the left bank of the Appomattox around the western side of Petersburg, to and across the James and to the north-eastern side of Richmond. They consisted of a double series of redans, redoubts, and infantry parapets, with other defences of abatis, stakes, and chevaux-de-frise, facing each other, well mounted with guns, and manned by the tried armies which for years had confronted each other on the soil of Virginia. The war had taken on a distinctly new aspect, and the engineer for the time being had replaced the field-officer in the conduct of operations.

The monotony of engineering operations was broken by brisk field-work at the north. Sheridan early in June was sent with a large cavalry force to break up the Central Railroad and cut the Kanawha Canal, channels of supply to Richmond. He found himself, however, confronted by Wade Hampton with a strong body of cavalry, and after a spirited engagement rejoined the army without having accomplished his chief purpose. On the other hand, Lee, with the hope of creating a diversion in his favor, sent, on June 13, Gen. J. A. Early with a force variously estimated at from 8000 to 15,000 men up the Shenandoah Valley, to threaten Washington and alarm the Federal authorities. Hunter, who had been advancing on Lynchburg, was forced to retreat across the mountains to West Virginia, and Early, by a rapid march, reached and crossed the Potomac without opposition on July 5, defeated Gen. Wallace at the Monocacy on the 9th, and on the 11th appeared before Washington, his approach being heralded by wild reports of the magnitude of the force under his command.

Had Early been a day sooner he might have entered and captured the city with little difficulty, but the delay occasioned by Wallace's defeat at the Monocacy saved the Federal capital. The troops ordered to its defence reached there on the 11th, and when Early, on the morning of the 12th, prepared to attack, he found the intrenchments full of men. He at once began to retreat, and made his way with all haste back to the Valley. His subsequent career may be

quickly disposed of. On the 23d he defeated Gen. Crook at Kernstown. Crossing the Potomac again, he sent a cavalry force into Pennsylvania, which occupied and burned the defenceless town of Chambersburg. Sheridan was now placed in command in the Valley, and defeated Early in the successive battles of Winchester and Fisher's Hill. On October 19 Early surprised the Union force in camp at Cedar Creek, and drove it back in great confusion towards Winchester. Sheridan, who had been absent at Washington, was on his way to the army from Winchester while the battle was going on, and heard in the distance the roar of the cannon. Then took place the remarkable incident of his dashing ride to the front, his rallying of the fugitives by the magnetism of his presence, and his turning of the tide of flight into an irresistible charge on the hitherto victorious enemy. Early's force was defeated and almost destroyed, only a small remnant of the army escaping. This ended the conflict in the Shenandoah Valley. Lee's diversion had signally failed.

Returning to the siege of Petersburg, the next occurrence of notable interest was the mine explosion of July 30. This attempt to mine the Confederate works was originally proposed by Lieut.-Col. Henry Pleasants, of the Forty-eighth Pennsylvania, a skilful mining engineer. The mining operations were placed under his charge, and were conducted so expeditiously that by July 23 the mine was finished and charged with 8000 pounds of gunpowder. It extended under a Confederate salient that was opposite to Burnside's position. The early morning of July 30 was fixed for the explosion, and a large force gathered for the charge, while orders were issued to threaten Lee's right and divert his attention from the real point of attack. At 4.45 A. M. on the 30th the explosion took place. The effect was tremendous. An immense mass of earth was hurled into the air, together with stone, timber, cannon, muskets, and mutilated corpses; 200 men were killed, and a cavity torn in the Confederate lines 135 feet long, 90 wide, and 30 deep. A heavy cannonade was at once opened all along the line, to which the astonished and dismayed Confederates replied but feebly. The way seemed open for the easy capture of this portion of Lee's works.

The opportunity was lost by delay. The charging column moved slowly and feebly, halting in the crater as if seeking shelter. A division of colored soldiers attempted to storm the hill beyond, but the delay had enabled the Confederates to recover from their surprise, and these troops were driven back into the crater. Here were huddled a large body of disordered troops, on whom the Confederates, hurrying from all quarters to the spot, poured a concentrated fire of musketry and artillery. The slaughter was dreadful, and a disorderly flight began. The result was a loss to the Union forces of about 4400 men, mostly captured, and of less than 1000 to the Confederates; all due, as Grant declares, to inefficiency of the corps commander and incompetency of the division commander who led the assault. An hour passed before the Confederate fire was of any importance, and that hour, if diligently employed, would have sufficed for complete success.

The leading purpose of Grant's later operations was to seize and hold the Weldon and Southside Railroads, the latter of special importance from its usefulness as a Confederate channel of supply and since its capture would open the way to the possession of the Danville Railroad, the remaining channel of communication between Richmond and the South. The possession of this road would force the evacuation of Richmond and the desertion of the formidable line of defensive works which Lee's army had erected with such toil. With this object in view Grant steadily extended his lines south and west of Petersburg, while Lee faced him at every point with new earthworks covering the important arteries of travel which his antagonist

wished to seize. The work of intrenching, however, did not yet supersede all active measures of assault. A vigorous attack was made on the Confederate works to the north of the James on Aug. 13, and repeated on the 16th, while on the 18th the Confederates assailed and were repulsed. The result of these operations was a loss of about 5000 Union soldiers and nearly as many Confederates, with no advantage in that quarter beyond that of the depletion of Lee's weakened ranks.

This affair, however, served as a cover to a more important one. Taking advantage of the absence of many of Lee's troops, who had been sent to strengthen the Richmond lines, Grant ordered a vigorous movement, to secure possession of the Weldon Railroad. On the 18th Warren advanced with the Fifth corps, and reached the railroad without opposition. Leaving Griffin to hold it, he moved with his other divisions towards Petersburg, but ere he had advanced far a Confederate force suddenly attacked his flank, taking 200 prisoners. The assailing force was soon repulsed, and Warren held his ground, but with a loss of about 1000 men. On the following day Warren was attacked in flank by a heavy force under Hill, Crawford's and the right of Ayres' divisions being driven back, with a loss of 2500 men as prisoners. But the railroad was held, and reinforcements coming up Hill hastily withdrew, suffering Warren to recover his lost ground. He at once intrenched his position, satisfied that Lee would do his utmost to recover the road. Three days afterwards the expected attack came. A cross fire of thirty guns was suddenly opened upon his lines, and then two columns of infantry advanced, one in his front and the other on his flank. He was well prepared, however, and easily repelled the front attack, while the flanking column was driven back with a loss of 500 prisoners. In this assault the Confederates lost 1200 men. Warren's total loss in the movement was 4450 men, but he held possession of the road, which Lee made no further effort at this point to recover.

On the day of this last battle, Aug. 21, Hancock moved in Warren's rear and struck the Weldon Railroad at Reams' Station, at which point he was vigorously attacked by Hill on the 25th, and after a desperate conflict forced to retire, with the loss of 2400 men, 1700 of whom were made prisoners. Hill's loss was little less, and he also soon after retired. But this success was of no avail to the Confederates. The Weldon road was irretrievably lost, and the first step in Grant's purpose of cutting off Lee's communication with the South gained.

A month passed in comparative quiet, at the end of which time another assault was made upon the Confederate works, this time north of the James, intended, as Grant states, to prevent Lee sending reinforcements to Early. Gen. Butler received orders to cross the river with the Tenth and Eighteenth corps under Ord and Birney, and Kautz's cavalry, and to attempt by a rapid movement to capture Richmond before Lee could move troops to its defence. The river was crossed on bridges muffled with hay on the night of the 28th, and on the 29th Battery Harrison, the strongest fort in that part of the works, was stormed and carried by Ord's corps, while a strong redoubt on Spring Hill was captured by a storming column of colored troops from Birney's command. These positions were strongly contested, both sides losing heavily, and so important did the Confederates consider Fort Harrison that a desperate effort was made to retake it, under Gen. Lee's immediate direction. He massed some of his best troops against it, but they were repulsed with severe loss, and the captured intrenchments held. Meanwhile Kautz with the cavalry had reached a point within three or four miles of Richmond, when he was attacked and driven back with loss, his pursuers in their turn encountering the Tenth corps and being repulsed with considerable

loss. The total Union losses in this enterprise were 2272 killed, wounded, and missing.

The attack on these intrenchments was only a part of Grant's plan. While the Confederates were struggling desperately in the vain effort to recover their lost works, a vigorous movement was made by Warren on the opposite end of the Union lines, in the direction of the Southside Railroad. This movement took place Oct. 1-2, the Confederates, who fought fiercely to maintain their positions, being gradually pushed back towards the Boydton road. As a result a position was gained and held about three miles west of the Weldon road, with a loss of about 2500 men. In this connection it is also necessary to speak of an effort made by Gen. Butler to cut a canal across a narrow neck of land known as Dutch Gap on James River, which would shorten the stream six or seven miles and enable the fleet to flank several important Confederate works. This effort failed, there not being depth enough of water gained for the intended purpose, the bulkhead, which was blown out with gunpowder, falling back and choking the channel.

The next offensive movement was made by the Confederate forces. On Oct. 7, Kautz's cavalry, north of the James River, was attacked and driven back, losing heavily in killed, wounded, and missing, and all its artillery. This was followed by an attack in force on the Union intrenchments, which was repulsed with severe slaughter. On the 13th Butler made an assault on some new Confederate works, and was similarly repulsed. One further advance movement was made before the armies went into winter quarters. On Oct. 27, the Fifth and Ninth corps were put in motion with the hope of flanking the Confederate lines and seizing the Southside Railroad. Part of the force, however, soon found itself in swampy ground covered with dense thicket, which divided and disordered the several divisions. At this juncture a portion of Hill's corps suddenly fell on an advance brigade and drove it back in confusion with the loss of two guns. The triumphant Confederates pursued eagerly, but suddenly found themselves in presence of a supporting column, and were repulsed with a loss of 1000 prisoners, while 200 of their men rushed into Crawford's lines and were also taken. A vigorous push at that moment might have dispersed or destroyed the whole Confederate division, but night was at hand, the Union commanders in ignorance of each other's position, and the country impracticable. Night fell before anything of importance could be accomplished. The losses on both sides were heavy and nothing was gained in position, the Union column being withdrawn during the night to its former position.

This ended active operations for the winter. For a period of nearly six months the armies had confronted each other, fighting many severe battles, while in the interval almost daily cannonading and picket-firing, with occasional sanguinary encounters, took place along the lines, the total loss from May 1 to November 1 to the Army of the Potomac being given at 88,387. If to this be added the loss of the Army of the James the grand total would be nearly 100,000. Of these 30,000 subsequently rejoined the army, making the eventual loss 70,000. The Confederate loss during the same period has been estimated at 40,000.

In was February, 1865, before further movements of military importance took place. Grant's army had been weakened to aid in operations elsewhere, particularly those against Fort Fisher (*q. v.*), and the troops lay at rest for months, the only movements being cavalry raids outside the lines, and an ineffectual effort on the part of the Confederates to send a squadron through the canal at Dutch Gap and destroy the pontoon bridges below. On Feb. 3, 1865, a conference was held at Hampton Roads between Pres. Lincoln, Secretary Seward, and a party of peace commissioners, including Vice-Pres. A. H. Stephens from the Confederacy. Nothing came of this, however, and it was

decided that the war should go on. Two days afterwards (Feb. 5), another effort was made to win the coveted prize of the Southside Railroad. It was decided to throw a flanking column along Hatcher's Run to the right of the Confederate works, take them in reverse, turn north, and seize the road. This movement was led by Warren, and included the Second and Fifth corps and Gregg's cavalry.

The cavalry were successful in clearing the ground in front of Reams' Station, and encamped for the night on Rowanty Creek. Meanwhile the Second corps crossed Hatcher's Run, and, finding the Confederates in a strong position, threw up temporary earthworks which were soon furiously assailed. The assault was twice repeated, but in vain, and at nightfall the Confederates withdrew. During the night the Fifth corps took position on the left of the Second, and other corps were moved up within supporting distance. Severe fighting took place on the 6th. Gregg's cavalry, which now covered the Fifth corps, was heavily assailed by Confederate cavalry, and towards evening pushed back to Hatcher's Run. Ayres and Crawford were successively assailed and driven back, the assault next falling on Humphreys, who held his ground and repulsed the foe in disorder. The troops were now rallied behind the earthworks which had been thrown up on the previous day and stood firm, the result of the conflict being the permanent extension of the Union lines to Hatcher's Run. The Union loss was nearly 2000, the Confederate about 1000 men.

Towards the end of March Grant prepared for still more decided and aggressive movements. As a preliminary it was important to destroy the Confederate power north of the James, and Sheridan was sent with a strong cavalry force for this purpose. With about 10,000 men that dashing leader rode up through the State, the first resistance of importance being met at Waynesboro, where Early, with 2500 men, was strongly intrenched. Yet Custer, in the advance, rode over his intrenchments and captured 1700 of his men, the remainder being thoroughly dispersed. Custer lost less than a dozen men. About a million dollars worth of Confederate property was destroyed at Waynesboro and in the district to the west of it, and on March 3 Sheridan entered and took possession of Charlottesville, where he made a thorough destruction of the railroads and railroad property for eight miles southward. He now pushed for the James River. Here he found the bridges burned and the river too swollen with rains for his pontoons to be available, so he turned eastward, destroyed the James River canal, an important channel of supply to Richmond, burned bridges all over that region, and dashing north-easterly tore up fifteen miles of the Virginia Central Railroad. This done, he swept round by the Pamunkey River and White House, and rejoined the army on March 26. He had ruined 200 miles of railway, destroyed many bridges and great quantities of stores, and effectually disabled the Confederate power north of Richmond, while so alarming the authorities in that city that they began to pack up ready for flight. The field of operations was decidedly narrowed by this vigorous raid.

On March 24 Grant issued orders for a general movement on the 29th. Lee, perhaps expecting this, perhaps in pursuance of some plan which ill success rendered abortive, had devised a counter movement against the Union lines, which was put into effect in the early morning of March 25. It was directed against Fort Steadman, a strong work in the central region of the intrenchments, south of the Appomattox. It was in front of the Ninth corps, and formed a salient about 100 yards distant from the Confederate intrenchments. Gen. J. B. Gordon had command of the assaulting column, of 3000 or 4000 men, with strong forces ready in reserve. At 4 A. M., March 25, the movement began in a stealthy advance over the intervening ground. In a few minutes the column, unobserved, was in front of the fort, and was dashing up its parapets before the

garrison were fairly aware of their danger. No resistance was attempted, those who were not made prisoners fled, and the guns of the captured work were turned upon the neighboring redoubts, compelling their hasty evacuation. The moment was come for the supporting column to press forward, disperse the troops in rear of the fort, seize the City Point Railroad, and force Grant to some hasty action in defence of his base of supplies. This was not done. For some unknown reason the advance was not made, and the promising opportunity was lost. Gordon was left to bear the brunt of the assault which quickly fell upon his late victorious troops. Fort Hascall, to the left of Fort Steadman, opened on it a terrific fire, under cover of which a heavy column of infantry advanced, and a scene ensued not unlike that which followed the mine explosion. The assailants were in a trap. It was impossible to escape, for the space leading to their own works was swept by artillery fire. Of those that sought to fly the greater number fell, and the bulk of the assailants surrendered rather than attempt it. The attack had failed, Lee's army had been depleted to the extent of 4000 men, and Meade, surmising that Lee must have weakened his lines for this movement, ordered a general advance of the Second and Sixth corps. As a result the strongly intrenched picket line of the Confederates was seized and permanently held.

The attempt to create a diversion in favor of the Confederates had signally failed, and the preparations for the designed movement of the Union army went actively on. A movement in great force was designed, for the general purpose, as Grant states, of placing himself in position to check the flight of Lee's army, which he feared might take place at any moment, and also for the capture of the works covering the Southside Railroad, the possession of which would leave Lee but a single avenue of supply. Lee's intrenched line now extended south-westward from Petersburg to and for some distance beyond the junction of Hatcher's Run with the Boydton road, while four miles westward was a detached line of works, stretching along the White Oak road and covering a strategic point at the junction of several highways known as the Five Forks. It was against the latter intrenchments, the extreme right of Lee's works, that the grand turning column began its march, on the morning of March 29. The Ninth corps, under Gen. Parke, and part of the Army of the James, under Gen. Weitzel, were left to hold the line of Federal intrenchments, and the remainder of the army was put in motion.

Sheridan was sent with the cavalry with orders to ride round the Confederate lines and seek to destroy the contested railroads. He rested for the night at Dinwiddie Court-House, several miles south of Five Forks. On the morning of the 30th he received orders from Grant to change his plan, push round the enemy to his rear, and co-operate with the infantry column. The latter, consisting of the Fifth and Second corps, led by Warren and Humphreys, had met some opposition on the 29th, Warren losing 370 men, but repulsing the enemy. They rested for the night in front of the Confederate works on the line of the White Oak road.

Lee made hasty efforts to protect the imperilled point, but left the major part of his army to defend his works, not knowing but the movement might be a ruse to cover an attack elsewhere. The force sent to Five Forks numbered about 15,000 infantry, with Fitzhugh Lee's cavalry. During all day of the 30th it rained furiously, making the roads almost impassable, and the Union troops remained in their lines. On the morning of the 31st the rain had ceased, but the ground was still so muddy that it was deemed inadvisable to move. Lee thought otherwise. His situation was desperate, and he felt it necessary to repel the line before him. Sheridan was too far distant to cover Warren's left flank, and on this flank, which was entangled in the intricacies of a swampy forest, there fell a sudden and

vigorous Confederate charge. Ayres's division was driven back in confusion, falling upon and breaking Crawford's, and for a moment disaster threatened the Union army. But Griffin's division stood firm, the broken troops rallied behind it, and soon a counter-charge was made which struck the Confederates on their left flank and hurled them back behind their intrenchments with a heavy loss, mostly of men made prisoners. At the same time Humphreys tried to carry the works in his front, but failed. Meanwhile, Sheridan had advanced part of his cavalry towards Five Forks. These encountered and drove back the Confederate cavalry, but the latter were reinforced with infantry, and Sheridan's men in turn were driven back to Dinwiddie Court-House. Here they joined the main body, the cavalry were deployed on foot, and the pursuers were in their turn repulsed. Night fell before they could renew the attack.

Early on the morning of April 1 Sheridan was reinforced by an infantry division of the Fifth corps, and at once started in pursuit of his late assailants. As he advanced he was joined by the remainder of the corps. Leaving the infantry at the point where they had joined him, he pressed boldly on with the cavalry, and by 2 P. M. had driven the enemy into their works at Five Forks. Halting here, he ordered Warren to advance to the White Oak road and attack the Confederate works. There was considerable delay in this movement, and the advancing column met with resistance which threw a part of the line into disorder, but this was soon remedied, and Ayres made an impetuous charge on the Confederate right, carrying a portion of the line and capturing more than a thousand men with several battle-flags. At the same time Merritt's cavalry charged the line in his front, and Griffin carried the works on the left, taking 1500 prisoners. While this was proceeding Crawford turned the left of the Confederate line, cut off retreat in the direction of Petersburg, and turning southward struck the enemy in the rear, capturing four guns. The Confederates were now in a desperate situation, with the cavalry on their front and right, the infantry on their left and rear, yet they continued to fight manfully, until simultaneously the cavalry charged over the works, and Ayres and Griffin, turning their flanks, bore down on them in a furious assault. Defence was no longer possible, many of the defenders threw down their arms, while the rest sought safety in a westward flight, in which they were pursued for miles by Merritt's and McKenzie's cavalry. Thus ended the battle of Five Forks, the Union loss being about 1000, the Confederate loss about 6000 in prisoners, besides a large number killed and wounded. It had a much more important result, however. It opened the Southside Railroad to capture, and reduced Lee to a single channel of communication with the South. But Sheridan could not overlook Gen. Warren's want of promptness at a critical time, and on April 2d sent him to Gen. Grant, who approved Sheridan's action and assigned Warren to less arduous duty.

The success at Five Forks was immediately followed by a bombardment of the works around Petersburg, which was kept up throughout the night and followed by a general assault in the morning. This assault was successful at nearly every point. The works in the vicinity of Hatcher's Run were taken, and about 3000 prisoners with much artillery captured, while the Southside Railroad was reached at several points. At the same time the Ninth corps attacked and carried the lines in its front, driving back the enemy to the inner line of works immediately around Petersburg. Here the Confederates were concentrated and strong, Longstreet's corps being brought up from the defences of Richmond. Vigorous efforts were made to regain some of the works which had been carried by the Ninth corps, Heth charging at the head of his division, and pressing so heavily that supporting troops had to be ordered up from City Point. In this movement A. P. Hill, one of the best of Lee's corps commanders,

was shot dead. Heth was repulsed, and two strong works close to Petersburg, Forts Gregg and Whitworth, carried by assault. Meanwhile Sheridan and Miles had captured an intrenched work at Sutherland Station, on the Southside Railroad. The prisoners taken during this series of assaults Grant states at 12,000.

That Richmond must be evacuated, and at once, was now evident. Any delay would have subjected the defending army to the danger of having every avenue of supply and retreat cut off. The Confederate authorities were advised of the necessity of flight. A wild panic prevailed in the city, and about 8 P. M. Pres. Davis left by the Danville Railroad, while by midnight all the Confederate authorities had departed. The army had similarly been making preparations for a hasty departure. Along the north bank of the Appomattox moved long lines of infantry and artillery through the gloom of the night, over the roads leading to Amelia Court-House. By midnight the evacuation was completed. As morning approached the marching troops saw in the distance behind them a blinding flash of light, followed by a loud explosion, while a lurid glare lit up the gloom of the skies. The first was the blowing up of the magazine at Fort Drewry, the second the conflagration of the city itself, which had been left in flames.

This arose from the attempt to destroy certain large warehouses of cotton, tobacco, and other property, which Gen. Ewell had been ordered by the War Department to set on fire, despite the remonstrances of prominent citizens. When the warehouses were in flames a fresh breeze carried the fire to other buildings, while an intoxicated mob, partly composed of soldiers, reeled through the streets, pillaging stores and committing other excesses, perhaps firing other buildings. The fire spread till nearly a third of the city was laid in ashes. The explosion of the magazine and of several Confederate iron-clads that were blown up, and the subsequent glare of the burning city, apprised the besiegers of what was going on. Early on April 3 Gen. Weitzel, in command north of the city, marched in and took possession, and at once endeavored to extinguish the conflagration and check the excesses of the mob.

On the same morning it became evident that the defenders of Petersburg had vanished during the night. They had stolen away so silently as to give no warning of their flight. The abandoned works were at once entered, and the whole army started in pursuit. Sheridan, with the cavalry and the Fifth corps, was already well out to the west, and moved so expeditiously that by afternoon of the 14th he had struck the Danville Railroad at Jetersville, seven miles south-west of Amelia Court-House, and directly across Lee's line of retreat to Danville.

Meanwhile Lee was in unexpected difficulties. He had marched directly to Amelia Court-House, at which point he had directed a provision train to be left, but some stupid official had sent the provision cars forward to Richmond with the remainder of the train, and the much-needed supplies were being consumed in the conflagration of that city at the moment when the hungry troops reached the point where they expected to find them. This error was fatal to Lee's hopes. Whatever his plans, whether to reach the mountains or to attack the detached columns of his pursuers, the need of food became paramount, and a large part of his force had to be sent out to forage for supplies.

Not until the evening of the 5th could the retreat be resumed, and then with a very inadequate supply of food. Sheridan was by this time too strongly reinforced to be safely attacked, and the line of march was directed westward, towards the mountain region. On that evening a Confederate train of 180 wagons, moving westward, had been destroyed by a party of cavalry, and on the 6th the force at Jetersville advanced upon Amelia Court-House to attack Lee, who, however, had left that place, and was marching rapidly towards Deatonville. The cavalry followed at full

speed, while the infantry was pushed forward with all rapidity. Sheridan was seeking to outmarch Lee and head off his columns. Near Deatonsville he sent Crook to attack a Confederate wagon train, which was strongly defended. Crook was repulsed, but meanwhile Custer had reached the line of retreat at Sailor's Creek, a small stream farther on. Here, being joined by Crook and Devens, he pierced the Confederate line, not only capturing 400 wagons, 16 guns, and many men, but cutting off Ewell's corps, which formed the rear guard of Lee's army. Sheridan at once ordered this corps to be attacked and detained till additional troops could come up. Ewell's resistance was vigorous, but his assailants increased until he was enveloped in a network of charging horse and foot, when his men threw down their arms and surrendered. About 7,000 men were made prisoners, among them Ewell and four or five other generals.

At this time Ord was moving rapidly towards Farmville on the line of retreat, and had sent forward a light column of infantry, under Col. Washburn, to destroy the bridges at this point. Later Gen. Read was sent with some cavalry to bring him back, but, on the contrary, he attacked the van of Lee's army and detained it for a considerable time. In the end Read was killed, and all that remained of his force of 600 men captured, the enemy saving the bridges. But Read's daring attack had occasioned the Confederates the loss of much valuable time, during which Ord was rapidly approaching. During the night Lee succeeded in crossing the Appomattox over the bridges at Farmville with what was left of his shattered army. He tried to prevent pursuit by burning the bridges, but the van of Humphreys' corps saved the wagon-bridge, and Barlow's brigade was soon across it. Only a weak rear guard was found, which quickly retreated, abandoning 18 guns, which their draught animals were too weak to draw farther. Of the men numbers had dropped from the ranks, thousands had let fall their muskets from sheer weakness, and the half-starved remnant of the army, worn out with want of sleep and food and the weariness of the march, dragged slowly onward over the muddy roads and the streams swollen with the spring rains.

On the night of April 6 a consultation had been held by a number of Lee's principal officers, at which it was decided that further resistance was hopeless, and that negotiations should be opened for a surrender. Gen. Pendleton communicated this decision to Gen. Lee, but the latter declared that all hope was not yet lost, and that he was still determined to resist. There were supplies at Appomattox Court-House. Could he obtain these and cross the Staunton River he might be able to maintain himself beyond that stream until a junction could be made with Gen. J. E. Johnston, then in North Carolina. A slight success in battle encouraged him. Humphreys had crossed the Appomattox in pursuit with the Second corps, and came up in the afternoon of the 7th with the rear of Lee's army. He found it intrenched, the roads being defended with a line of works extending for a considerable distance. An assault was made by Miles's division, which was repulsed with a loss of about 600 men.

Meanwhile Sheridan was pushing forward with all speed, making every effort to get in Lee's front and cut off the route to Lynchburg which the fugitive army was pursuing. In the rear the infantry forces were moving with the utmost celerity, the whole Army of the Potomac being on the track of the fugitives, who were now reduced to about 10,000 effective men, though they numbered in all about 28,000. Many were defenceless from having thrown away their arms in the hurry of flight. On the 8th the retreat, being uninterrupted, progressed more expeditiously than on the previous day. Two days' rations had been obtained at Farmville on the evening of the 6th, while further supplies awaited the retreating army at Ap-

pomattox Court-House, toward which place it now strained forward.

But Sheridan was advancing rapidly upon the same point. On the 7th Gen. Crook had attacked a body of infantry guarding a wagon-train, but was repulsed and Gen. Gregg made prisoner. On the 8th Gen. Custer, in command of the advance, made a forced march of thirty miles to Appomattox Station on the Lynchburg Railroad, and captured four trains of cars loaded with the supplies upon which the last hopes of the fugitives had depended. The vanguard of the retreating army was just then approaching, and was pushed back by Custer, who had been reinforced by Devlin, to Appomattox Court-House, near which was Lee's main body; twenty-five guns, many wagons, and a large number of prisoners were captured. Sheridan hurried forward the remainder of his command, and on the evening of the 8th the cavalry column stood directly across the pathway of Lee's army, while the infantry were advancing by forced marches upon its front and rear. The last moments of the Army of Northern Virginia were at hand.

During the last two days correspondence had been going on between Grant and Lee in reference to surrender. Grant at 5 P. M. on the 7th wrote, demanding a surrender, as further resistance was hopeless. Lee replied, asking what terms he would offer. Grant rejoined on the morning of the 8th, insisting upon but one condition, that the men and officers surrendered should be disqualified from taking up arms again until properly exchanged. Lee replied that he had not intended to propose surrender, but to ask for terms only, and did not think the emergency had arisen for the surrender of his army, but would be pleased to meet Grant at 10 o'clock on the following morning, to confer on the question of the restoration of peace, but not upon surrender. Grant rejoined that such a conference would be useless, and that only by the Confederates laying down their arms could peace be secured and the destruction of life and property brought to an end.

Lee was well aware that his last hope lay in cutting his way through Sheridan's lines before they could be strengthened by infantry. Orders for an advance were given, and at 3 A. M. on the 9th the Confederate lines moved silently forward. Gordon commanded the advancing column, which was supported with cavalry and thirty pieces of artillery. The charge on Sheridan's men, who had dismounted to meet it, was made with such energy that they were driven back. Sheridan, who had just reached the front, and was hurrying up the wearied infantry, sent orders to the cavalry to fall back slowly, but to offer resistance at every point until assistance could reach them. Gordon's line continued to advance while this movement was being made, when the cavalry suddenly opened its ranks, and revealed to the eyes of the dismayed Confederates a solid line of men in whose hands glittered muskets and bayonets. The infantry had arrived, and the last hope of the fugitive army vanished.

Gordon sent back to Lee, saying that it was impossible to continue his advance without powerful reinforcements. No such reinforcements could be sent and but one course remained—to treat for surrender. The bugles had sounded and the cavalry again sprung to their saddles, ready to charge, when a white flag appeared in token of surrender. At the same time a reply from Lee to Grant's last note was sent across the lines, in which he agreed to a meeting in reference to surrender. Grant, who was hurrying forward to the front when he received Lee's note, at once returned an assenting answer, and arrangements were made for the interview in the parlor of the dwelling of Wilmer McLean, at Appomattox Court-House. Here the meeting between the two commanders took place, at 2 P. M. on Palm Sunday, April 9. The terms of surrender were discussed and settled, and were signed about 3.30. Grant's offer of terms was very

lenient. He simply required that Lee, with his officers and men, should give their parole of honor not to take up arms against the government until regularly exchanged. All military material and public property was to be handed over, but the officers were allowed to retain their side-arms and private horses and baggage. Officers and men were to be allowed to return to their homes, and not to be disturbed by United States authority so long as they observed their paroles and obeyed the laws. In addition to these written terms Grant agreed, at Lee's suggestion, to allow all Confederate cavalry that owned their horses to retain them, saying that they would need them to till their farms.

At Lee's request the exhausted Confederates, who had been living for several days on parched corn, were granted rations, which were served to them out of the car-loads of provisions which had been captured by the cavalry. On Wednesday, the 12th, the captive soldiers were marched to an appointed place near the village, where they stacked their arms and gave their paroles, each company or regimental commander signing the parole for the men of his command. The total number paroled was 2781 officers and 25,450 men, making 28,231 in all. In addition there had been taken prisoners, since March 29, 19,132 Confederates, besides the large number killed and wounded and all those that had dropped from the ranks during Lee's headlong flight, so that Lee's army at the time of the general assault must have numbered considerably over 50,000 men.

Thus ended the career of the Army of Northern Virginia, whose members at once dispersed, the soldiers hastening to their homes in all directions, while Gen. Lee returned alone to Richmond, where for some months he resided as a private citizen. His surrender brought the war to an end in all quarters. Johnston, as soon as he heard of it, at once proposed to surrender to Sherman, and what troops remained in arms throughout the Confederacy quickly followed the example, the last to surrender being a force under Kirby Smith, in Texas, who continued to resist till May 13, when their main body was surrounded and forced to yield. Smith's formal surrender was made on May 26, and with it ended the last show of resistance in the great civil war, which for four years had spread ruin and desolation throughout the country.

(C. M.)

RICKETTS, JAMES BREWERTON (1817-1887), general, was born in New York, June 21, 1817. He graduated at West Point in 1839 and entered the artillery service. He was engaged in frontier duty until the Mexican war, in which he served with distinction at Monterey and Buena Vista. He was again employed on the frontiers and in 1859 had an engagement with the Mexican bandit Cortinas. At the outbreak of the civil war he was placed in command of a battery of rifled guns, which he used skillfully at the battle of Bull Run. But being severely wounded, he was captured and for eight months was a prisoner in Richmond. His commission as brigadier-general was made to date from the battle. He commanded a division in the Third corps of Gen. Pope's army, and was wounded in the second battle of Bull Run. At Antietam, when Gen. Hooker was wounded, Ricketts succeeded to the command of his corps. He was engaged in the subsequent campaigns against Richmond and in the Shenandoah Valley, and reached the rank of major-general. He was retired from active service in 1867, and served in courts-martial for two years longer. He died at Washington, D. C., Sept. 22, 1887.

RIDDLE, MATTHEW BROWN, exegete, was born at Pittsburg, Oct. 17, 1836. He graduated at Jefferson College, Philadelphia, Pa., in 1852, and at New Brunswick Theological Seminary in 1859. After a year's study in Germany, he became in 1861 chaplain of a New Jersey regiment, and then held pastorates of Reformed churches at Hoboken and Newark. After

a second visit to Europe he was in 1871 appointed professor of New Testament exegesis in the Hartford Theological Seminary, and in 1887 was called thence to the Western Presbyterian Theological Seminary at Allegheny, Pa. Dr. Riddle was a member of the American Committee on the revision of the New Testament, translated and edited four Pauline Epistles in Dr. Schaff's edition of *Lange's Commentary* (1869), and contributed to Dr. Schaff's later commentaries. He also revised Dr. Edward Robinson's *Harmony of the Gospels*, Greek (1885) and English (1886). To the American edition of the *Ante-Nicene Fathers* he edited the *Teaching of the Twelve Apostles* and *Second Clement*, and contributed to the *Nicene Fathers*. He has also prepared and edited other works relating to the New Testament, and has contributed to this work several articles on New Testament topics.

RIDGWAY, ROBERT, ornithologist, was born at Mt. Carmel, Ill., July 2, 1850. At an early age he showed fondness for natural history and a correspondence with Spencer F. Baird (*q. v.*) in 1864 led to his appointment a few years later as naturalist in Clarence King's U. S. geological survey of the 40th parallel. In the *Report* of this exploration he edited the department of ornithology. He was afterwards connected with other government surveys, and in 1879 was appointed curator of the department of birds in the U. S. National Museum. He has published over 200 papers on ornithology, including several catalogues. He was associated with S. F. Baird and T. M. Brewer in preparing a *History of North American Birds* (3 vols., 1874), and has since published *Water Birds of North America* (1884), *Nomenclature of Colors for Naturalists* (1886), and *Manual of North American Birds* (1887).

RIEDEL, FRIEDRICH ADOLPH, BARON VON (1738-1800), Hessian general, was born at Lauterbach, Hesse, June 3, 1738. He studied at Marburg University, and entering the army was employed by the British in the Seven Years' War. Having risen to the rank of major-general in 1776, he was sent to America in command of a division of Brunswick troops, hired to Great Britain. His wife, daughter of the Prussian minister Massow, accompanied him. After a year spent in Canada, Riedesel was called to take part in Burgoyne's expedition. He fought at Ticonderoga, Stillwater, and Saratoga, and surrendered with Burgoyne Oct. 17, 1777. With his wife he was taken to Albany, where Gen. Philip Schuyler handsomely entertained them until they were ordered to Cambridge, Mass. He remained a prisoner until November, 1780, having spent some time in Virginia. He next had command of Long Island, but in 1781 went to Canada and two years later returned to Germany. In 1787 he became lieutenant-general and had command of the Brunswick troops in Holland until 1794, when he was placed in charge of the city of Brunswick, where he died Jan. 6, 1800. Both Baron Riedesel and his wife wrote interesting *Letters and Journals* of their residence in America, which give valuable side-light on the war of the Revolution. They were translated and edited by W. L. Stone (Albany, 1867 and 1868).

RIEL, LOUIS (1844-1885), Canadian rebel, was born at St. Boniface, Manitoba, Oct. 23, 1844. His father was a leader of an Indian revolt against the rule of the Hudson Bay Company in 1849. The son was educated in the Jesuit College at Montreal, and in 1869 was made secretary of a committee of the Metis, or half-breeds, of the North-west Territory, to demand from the Dominion of Canada part of the sum paid to the Hudson Bay Company for its lands. When this was refused, he was made president of a provisional government at Fort Garry. On the approach of Sir Garnet Wolseley's expedition, early in 1870, Riel fled from the country but afterwards returned and was not molested. In 1873 he was elected to the Dominion Parliament, but was not permitted to take his seat, and after a second election he was expelled. In Feb-

ruary, 1875, he was sentenced to banishment for five years, and forfeiture of political rights. He removed to Montana, but in July, 1884, returned to his former haunts and fomented rebellion. In March, 1885, he again attempted to form a government and attacked employes of the Dominion. The rebellion was suppressed by Gen. Middleton and Riel was carried to Regina for trial. He was convicted of treason and executed Nov. 16, 1885. There is strong proof that he was insane, and the French Canadians who sympathized with his actions strongly denounced the government for its harsh measures towards him.

RIGGS, ELIAS, missionary, was born at New Providence, N. J., Nov. 19, 1810. He graduated at Amherst College, Mass., in 1829, and at Andover Seminary in 1832. While here he prepared some Chaldee text-books. He was then sent by the American Board of Missions to Greece, and in 1838 transferred his work to Smyrna. In 1853 he removed to Constantinople, where he has since remained, except when visiting the United States in the interest of his work. In 1857 he came to New York to have his translation of the Bible into the modern Armenian language stereotyped, and during his stay taught Hebrew in the Union Theological Seminary. He translated the Bible also into the Bulgarian language and prepared a *Bible Dictionary* and *Harmony of the Gospels* in that language. The translation of the Bible into modern Turkish, having been thoroughly revised by a committee of which he was a member, was issued in 1886. Dr. Riggs has also prepared grammatical works on the Armenian, Turkish, and Bulgarian languages, and published tracts and hymns in those tongues. He also published suggestions of emendations for the English Old Testament (1873) and modifications of the revised version of the New Testament (1883).

RIGGS, STEPHEN RETURN (1812-1883), missionary, was born at Steubenville, Ohio, March 23, 1812. He graduated at Jefferson College, Pa., in 1834, and having entered the Presbyterian ministry was sent by the American Board to a mission near Fort Snelling in 1837. His service was among the Dakotas, for whom he prepared various books, as well as a *Dakota Vocabulary* (1852) and *Grammar and Dictionary of the Dakota Language* (1852). During the Sioux war of 1862 Dr. Riggs and his family were obliged to flee. He then became chaplain of the expedition that marched against the hostile Indians. His later years were spent in field-work during the summer and in translating the Bible into Dakota during the winter. This translation was published in 1879. Dr. Riggs died at Beloit, Wis., Aug. 24, 1883. Besides his works in the Indian tongue, he published *Tahkoo Wakan, or the Gospel among the Dakotas* (1869) and *Forty Years among the Sioux* (1880). Altogether he published about fifty books relating to the language and the people to whom his life was devoted.

RILEY, CHARLES VALENTINE, entomologist, was born in London, England, Sept. 18, 1843. He was educated in France and Germany and in 1860 removed to the United States. Settling in Illinois he became practically acquainted with farm-life and edited an agricultural journal. In May, 1864, he entered the army and served till the close of the war. He then returned to his editorial work and in 1868 was made State entomologist of Missouri. His later work is sketched under AGRICULTURE, chap. ix., at end. He has contributed several articles to this work.

RINEHART, WILLIAM HENRY (1825-1874), sculptor, was born near Frederick, Md., Sept. 25, 1825. His early life was spent on a farm, but in 1846 he went to Baltimore, where he became a stonecutter. Soon his taste for high art was developed and he began modelling in clay. In 1855 he went to Italy and in 1858 he settled at Rome, though he made occasional visits to Baltimore. He completed the modelling of the bronze doors of the U. S. Capitol at Washington, left unfinished by Crawford. Among

his ideal works were *The Angel of the Resurrection*, *The Woman of Samaria*, *Leander, Hero, St. Cecilia*, *Latona and her Children*, *Atalanta*, and above all, *Clytie*, which he considered his masterpiece. It now belongs to the Peabody Institute of Baltimore, and in that city many others of his works have found owners. Besides numerous portrait busts, he executed for the State of Maryland the heroic statue of Chief-Justice Taney at Annapolis. Rinehart was cut off prematurely at Rome, Oct. 28, 1874. He bequeathed \$45,000 for a lectureship in Baltimore on sculpture and a fund for needy art-students.

RIOTS. The general principles of the law in regard to riots are the same in the United States as in England. The different degrees of criminality on the part of those participating in a riot are defined in substantially the same manner, but the penalties are generally milder than those imposed by the English statutes. The course to be pursued by the authorities in suppressing a riot is essentially the same as in England. The "riot act," which it is the duty of the sheriff, mayor, or other officer to read or attempt to read before proceeding to extreme measures, is almost identical in words and quite identical in substance with the English statute. The circumstances which justify and require the summoning of the military to the aid of the civil authorities are in substance the same, and the duties imposed upon them and their responsibilities are the same.

In law as well as in popular language and thought the chief characteristic of a riot is the sense of insecurity, the terror and distress which it causes among peaceable and quiet citizens. It is a breach of the peace on a great scale, aiming at the injury of individuals and the destruction of property in a tumultuous, disorderly, violent, and unlawful manner. The ultimate cause of a riot may sometimes be found in the existence of evils which afford just ground of complaint on the part of large classes of persons. But it almost invariably happens that an attempt to remedy such evils, by means of a riot, only ends in their aggravation. A large majority, however, of riots originate in prejudice, superstition, or ignorance, and are unmixed evils.

Many riots have become historical from their magnitude and from destruction of property and the bloodshed by which they were accompanied. We can here notice only a few, which may serve as characteristic specimens of such occurrences.

A minute and accurate knowledge of the anatomy of the human body is the indispensable foundation of the science of medicine. Such knowledge can only be acquired by the dissection of the body. But, even in the most civilized countries, large classes of the people, especially the more ignorant, have always regarded this treatment of the human body with aversion and horror, considering it as a kind of sacrilege. Hence the medical profession and especially medical students have in all countries been exposed to outbursts of popular fury. One of the most noteworthy of these outbursts occurred in the city of New York in 1788, and is known as the "Doctors' riot." In 1785 Dr. Richard Bailey obtained permission to use some rooms in City Hospital for delivering anatomical lectures to medical students and for use in making dissections and preserving anatomical preparations. Gradually there sprang up among the working classes a general belief that the medical students were stealing bodies from the cemeteries. On Sunday, April 13, 1788, some boys playing about the hospital found a ladder which afforded access to an upper window, and one, looking in, saw a student engaged in dissecting a body. He told his father, who spread the story among his fellow-workmen, and a crowd armed with their tools and other weapons gathered. The whole city was soon in an uproar; the hospital was surrounded and the doors broken in. The collection of anatomical specimens was destroyed. The

discovery of several "subjects" inflamed the fury of the mob, who now began to threaten the whole medical profession. Physicians took refuge in the jail, where they were guarded by the hastily summoned militia. Dr. Cochrane's house was ransacked in a fruitless search for subjects, while Dr. Hicks escaped by the roof. During the night bands of rioters marched through the streets, and the next morning were joined by some sailors. They now attempted to storm the jail, threatening to hang all the doctors. Gov. Clinton, Mayor Duane, Secretary Jay, Baron Steuben, Alexander Hamilton, and other prominent citizens endeavored to stay the fury of the mob. Appeals and threats were alike in vain. Finally, after Mr. Jay, Baron Steuben, and others had been badly wounded by stones, the governor gave the militia the order to fire. One volley sufficed. Five of the rioters were killed, seven or eight badly wounded, and the rest fled. The riot was at an end.

Whenever a widely extended abuse has become interwoven with the apparent interests, the prejudices, and the passions of large portions of the people, the early reformers who give utterance to protests against it are liable to encounter riotous demonstrations. From 1830 to 1840 riots of which the anti-slavery men were the victims were frequent in different parts of the United States. These riots were not, perhaps, intentionally but none the less effectually stimulated by the language and conduct of the most respectable citizens. In the summer of 1834 a mob attacked the houses of Arthur and Louis Tappan, prominent anti-slavery men. Having sacked the houses, they made a huge bonfire of the plundered furniture in the middle of the street. Mayor Lawrence called out the militia and they assembled in front of the city-hall. Meantime the mob surrounded the residence of the Rev. Dr. S. H. Cox (*q. v.*), barricaded the streets, and were proceeding to demolish the house. The militia, marching to its defence, were assailed with stones and other missiles, but finally succeeded in dispersing the mob without firing upon them.

Of riots originating in religious bigotry one of the most disgraceful that ever occurred in the United States was that which resulted in the burning of the Ursuline Convent in Charlestown, Mass., in 1834. The Ursuline order of nuns of the Roman Catholic Church was instituted in 1536, for the purpose of administering relief to the sick and the afflicted and of superintending the education of female youth.

In 1820, with the aid of funds contributed by a native citizen of Boston, four ladies of this order established a school in that city. In 1826 they removed to Charlestown, where a building erected for them was enlarged as the fame of the school increased. The number of nuns varied from four to ten, and the only restrictions upon their intercourse with outside society were such as are considered proper in any well-regulated female seminary. The number of pupils varied from 40 to 60, mostly children from respectable Protestant families, and the teaching was entirely free from any attempt to influence the religious convictions of the pupils. But the fact that the institution was called a convent and was under the patronage of the Roman Catholic Church excited the hostility of many people of Charlestown and the adjoining towns, who gave credence to absurd rumors. On Aug. 10, 1834, an inflammatory handbill was posted in various places. On the 11th the select men of Charlestown applied for permission to examine the interior of the building. Accompanied by the very lady who, it had been reported, had been forcibly detained and put to death for attempting to escape, they searched every nook and cranny, and when they left they assured the lady-superintendent that they would the next day in the public press inform the people that everything about the institution was of the most exemplary character. Yet, about 9 P. M. a mob began to gather around the building, which then contained 10 adults and 60 children. At 11

o'clock the rioters commenced their attack. The lady-superintendent twice appeared upon the piazza and endeavored to reason with the mob. Finding this in vain, she and her assistant gathered the children and led them to the garden, where they remained terrified spectators of the destruction of their home. Beds, clothing, furniture, including costly pianos and harps, were piled in the middle of the rooms. About 1 A. M. the torches were applied and the whole was soon in flames. The mob next attacked the library, or, as it was called, the Bishop's lodge, which was burned to the ground. Next they set fire to the farm-house and barn belonging to the convent. Finally they even broke open the tomb and wrenched the silver plates from coffins. While these things were going on thousands of people had assembled from Boston and the adjoining towns, but the authorities to their lasting disgrace did nothing to stay the work of destruction.

Scarcity of food has, in all ages and countries, been a prolific source of riots. Such scarcity in almost all cases is the effect of natural causes entirely beyond human control. The immediate result is a rise in prices, which the poorer classes of society almost always attribute to the action of speculators, and often by a riotous destruction of the very thing needed aggravate the evils from which they are suffering. The distress arising from the great financial revulsion of 1836 was augmented by a partial failure of the crops. It became necessary to import large quantities of wheat from Europe. During the winter of 1836-37 the price of flour in New York city rose to \$15 a barrel, and the distress among the poor was very great. Early in February placards were posted in streets headed: "BREAD! MEAT! RENT! FUEL! Their prices must come down," and calling a meeting in the park. About 6000 persons, mostly foreigners, assembled, and after listening to inflammatory harangues, started to attack the dealers in flour and grain. Mr. Eli Hart was reported to have over 50,000 bbls. of flour in his store, besides a large quantity of wheat. Thither the mob proceeded, and though the mayor with a large force of police endeavored to defend the building, his men were soon overpowered, the doors were broken in, and hundreds of barrels of flour were pitched into the street. They were broken by the fall, and the strange spectacle was presented of men who claimed to be starving trampling knee-deep in flour. Other stores were attacked, but large numbers of citizens joined with the police, and by nightfall the rioters were dispersed.

Of riots founded upon personal considerations stimulated by national prejudices, perhaps the most remarkable that has ever occurred in the United States was that known as the "Astor Place Riot." The tragedian Edwin Forrest, having met an unfavorable reception in England, attributed the hostile criticism of the English press to the influence of W. C. Macready. In 1849 the latter came to the United States to play a farewell engagement, which was so successful that he undertook a second engagement. Forrest's admirers determined to prevent this. On the first night of Macready's appearance in his second engagement, May 7, he was driven from the stage by the violence of a portion of the audience. Again on May 10 he presented himself before a brilliant audience, among whom a large number of policemen were interspersed. Champions of Forrest were also present, and when Macready appeared not only received him with hisses and yells, but hurled at him chairs, eggs, and other missiles. By the joint efforts of the respectable portion of the audience and the police, order was restored and the play went on. But a crowd of 20,000 persons had gathered outside, many being attracted merely by curiosity. Some active participants claimed to be defending the cause of an American against an English actor, but the larger part of the mob—roughs, rowdies, and thieves—were actuated solely by the love of disorder and the hope of plunder. While some were armed with pistols, others found a supply of weapons in stones

which had been piled up in repairing adjoining streets. A body of 300 policemen, detailed to defend the opera-house, were soon overpowered. Stones fell among the audience, and women in their terror crawled under the seats. The outer doors of the opera-house were of iron, very strong, and all opened outwards; now locked and barred, they withstood the assaults of the mob until succor arrived. At the request of the civil authorities Gen. Sanford, the division commander, had kept the Seventh regiment, N. G., in readiness, and now ordered them to the scene. Preceded by a company of cavalry ten abreast, they arrived at Astor Place about 9 o'clock; the cavalry charged through Astor Place from Broadway to Third avenue, but the showers of stones rendered the horses unmanageable. Then the Seventh regiment, under Col. Duryea, charged through Astor Place from Broadway to Third avenue, through Eighth street to Broadway, down Broadway to Astor Place again, and formed in line in front of the opera-house. The mob returned to the attack, and Gen. Sanford, Gen. Hall, Col. Duryea, Capts. Shunway and Pond were all severely wounded, together with a large number of the men. The mayor still declined to give permission to fire, but sheriff Westervelt assumed the responsibility. Recorder Tallmadge gave a last warning to the mob, and this being disregarded, the order to fire was given. The first volley, directed over the heads of the crowd, produced no effect upon the mob, but unfortunately resulted in killing and wounding some innocent persons in other streets. The next volley was fired point-blank into the midst of the mob with terrible effect. The regiment then recharged and the mob fled. But their leaders rallied them again in Eighth street and Lafayette Place and renewed the conflict. A third volley was enough. The rioters fled in all directions, and the struggle was ended. Twenty rioters were killed, and over 50 more or less severely wounded. None of the regiment were killed, but 150 were wounded, 70 so severely that it was necessary to carry them to their homes. Many of them carried the scars for the rest of their lives. Eyewitnesses were unanimous in the statement that the conduct of the regiment throughout was perfect. The regiment has on later occasions been called upon to aid in the suppression of riots, but generally all disorder has ceased the moment it appeared upon the ground.

The "Draft Riots" in New York city in July, 1863, occupy altogether too large a place in the history of the civil war to be treated here. But it may be remarked that the simple love of plunder was far more powerful than is generally supposed in prolonging the disturbance. Before the Colored Orphan Asylum was set on fire, all that was portable of the furniture was carried off uninjured, not only by the rioters themselves but by their wives and children.

Nearly all the riots which have occurred in the United States in recent years have been connected with what are called "labor troubles." Most of these disturbances have been brought to end without any extensive destruction of property and without bloodshed. (See STRIKES.) The great "Haymarket Riot" in the city of Chicago was of a different character. The great and acknowledged political and social evils existing in Europe have, during the present century, given rise to multifarious and contradictory schemes of reforms. One class of those who profess to seek the reformation of these evils regard the accumulation of property by individuals as the source of all the misery in the world. Their doctrine may be stated thus: the destruction of capital and the slaughter of capitalists is the indispensable preliminary to the removal of social evils. The name of "Anarchists" has been applied to these men, and they themselves have accepted the designation with alacrity and pride. Almost all the Anarchists have emigrated from Europe to the United States, some from fear of the law, others because they supposed that the greater freedom of speech and of the press in this country would afford them a better oppor-

tunity to propagate their doctrines. They also quickly observed the difference in the means available for enforcing the law and preserving public order in this country and in Europe. In Europe not only were the laws far more severe and the civil authorities more strict and less scrupulous in their execution, but every attempt of the Anarchists to carry out their designs was immediately and relentlessly crushed by a vast and well-disciplined standing army ever present and always ready and obedient. In the United States the preservation of law and order, as the Anarchists saw, depends almost exclusively upon the civil authorities. The only military force which they in case of necessity could call to their aid is the militia, composed of citizens who are usually engaged in their ordinary peaceful avocations. The regular U. S. army, only a handful when compared with that of any of the great powers of Europe, is widely distributed in small garrisons, mostly on the frontiers, and the assistance of any portion of it in the suppression of a riot could only be obtained after a compliance with tedious formalities. As a rule no military power is anywhere visible.

Various circumstances had made the city of Chicago a sort of head-quarters of the Anarchists. There they established an organ, the "*Arbeiter Zeitung*," in which the advocacy of arson and murder was hardly disguised. They held frequent meetings and labored vigorously to excite the enmity of the working people against their employers. On Saturday, May 1, 1886, about 40,000 laboring men struck work demanding that eight hours instead of ten should thereafter be considered a working day. Large processions of workmen marched through the streets, visiting the great industrial establishments and urging those who had returned to their work to join them. Business was almost entirely stopped. The railroads were at a standstill. The freight-houses were closed and barred, and the few freight-handlers who had not joined in the strike worked under the protection of guards with revolvers in their hands. The processions of strikers, especially those in which Germans, Poles, and Bohemians predominated, halted at intervals to listen to the inflammatory harangues of Anarchist orators. But no actual violence of any account was committed. On Monday morning, May 3, a great crowd gathered about the McCormick reaper-works and endeavored to prevent the hands from returning to work. They succeeded in forcing or frightening about 700 of the men into a compliance with their demands. About the same number entered the building and resumed work. At noon the company announced to these that the eight-hour day would be adopted, and that the men could also have a half holiday. But the crowd outside, unaware of the fact, assailed the men as they left the building. Some of them escaped by flight, and the others retreated into the building. The mob then began demolishing the windows with stones. A volley fired over their heads by the small guard within was greeted with shouts of derision, and the mob proceeded to attack the doors with crowbars. A patrol wagon filled with policemen drove into the crowd; the policemen alighted and drew their revolvers. But a large portion of the mob were also armed, and after discharging a volley of stones, followed it up with a volley of bullets. The policemen returned the fire. None of them were hurt but some of the crowd were wounded, and when a reinforcement of the police arrived the rioters fled. In the evening handbills printed in English and German were posted about the city calling upon workmen to meet on the evening of the next day, Tuesday, May 4, in an open place known as the "Old Haymarket," at the corner of Des Plaines and Randolph streets. At the appointed time about 1400 men assembled, many of whom had been prominent in the riot of the previous day. A violent rainstorm compelled some to retire, but the rest remained to listen to the speeches of the Anarchist orators. A police force of about 200 men, stationed at a short distance, were

kept informed of the proceedings of the meeting. The first speaker was quite moderate, the second more violent, and the third was so outrageous and his advice was received by the crowd with such marks of approval that the police captains decided that a serious riot could only be prevented by dispersing the meeting. A line of 170 policemen was formed and marched up Des Plaines street. When near the wagon from which the Anarchist orators had been speaking, the police halted and Capt. Wood ordered the crowd to disperse. Their answer was as terrible as it was unexpected. First a dynamite bomb was thrown into the midst of the police and this was immediately followed by a murderous fire from the revolvers of the rioters. Seven policemen were killed and more than fifty wounded. But the well-disciplined force did not quail; drawing their revolvers, they charged and dispersed the rioters after killing and wounding a large number.

Eight of the Anarchist leaders were arrested and tried in the following July. They were all convicted of murder, and according to the laws of Illinois their punishment was fixed by the jury which convicted them. One was sentenced to fifteen years' imprisonment, and seven were condemned to death. They were defended by able counsel and after conviction every resource known to the law was exhausted in the endeavor to escape the verdict. The case was carried to the State Supreme Court and then to the U. S. Supreme Court. By both these courts the verdict was affirmed. As a last resort recourse was had to the pardoning power and the mercy of the governor was invoked. This was so far successful that the sentences of two of the criminals were commuted to imprisonment for life. One of the others succeeded in obtaining the means of manufacturing a small dynamite bomb, with which he committed suicide by exploding it in his mouth. The other four were hanged Nov. 11, 1887.

An impartial examination of the history of a riot will in almost every case show that it is an unmitigated evil. By far the greater part of the terror and destruction by which a riot is accompanied falls upon those who are in no way responsible for the causes which have produced it. For this reason a riot tends to array the opinions and sentiments of the majority of peaceable and law-abiding citizens not only against the rioters themselves but also against the objects the accomplishment of which the rioters are striving to advance. Hence a riot is almost invariably not only a crime but a blunder. When a riotous assembly assumes the dimensions of a mob the great majority of the crowd is, in almost every case, composed of persons whose presence is due to curiosity alone. There is abundant evidence to show that many riots which have appeared formidable in extent, which have been accompanied by immense destruction of property, and which have required the united efforts of large civil and military forces and the loss of many lives for their suppression, would have dwindled to ridiculously small proportions if all persons who were peaceably disposed had retired the moment they saw that violence was contemplated. The safest course for the law-abiding citizen, the most effectual aid he can render to the authorities, and the highest duty he can perform, is simply to go home. If all good citizens adopt this course, in nine cases out of ten the riot will end without the destruction of property and without the shedding of blood.

(W. M. F.)

RIPLEY, ELEAZER WHELLOCK (1782-1839), major-general, was born at Hanover, N. H., April 15, 1782, being son of Rev. Sylvanus Ripley, D.D. (d. 1787), professor of divinity in Dartmouth College, and nephew of Rev. John Wheelock, president of the college. He graduated there in 1800, practised law in Maine, and was elected to the Massachusetts Legislature in 1810, and to the Senate in 1812. He then entered the army as lieutenant-colonel, and was engaged in Canada, being wounded at York (now Toronto). In 1814 he was made brigadier-general and took part in the battle

of Chippewa, and was wounded at Niagara. In the defence of Fort Erie he was shot through the neck, but recovered and received from Congress a gold medal. Resigning from the army in 1820, he settled in Louisiana, where he practised law. In 1835 he was elected to Congress and was still a member when he died at West Feliciana, La., March 2, 1839.

RIPLEY, HENRY JONES (1798-1875), Baptist minister, was born at Boston, Jan. 28, 1798. He graduated at Harvard in 1816, and at Andover Theological Seminary in 1819. For some years he was a pastor in Georgia, and in 1826 he was made professor of Biblical literature in Newton Theological Institution, and in 1839 he became professor of sacred rhetoric in the same. Resigning in 1860, he again engaged in evangelistic work in Georgia, but in 1865 he returned to Newton as librarian, and afterwards was associate professor of Biblical literature. He died May 21, 1875. Among his publications are *Christian Baptism* (1833); *Notes on the Gospels* (2 vols., 1837-38), and on some other parts of the New Testament; *Sacred Rhetoric* (1849); *Church Polity* (1687).

RIPLEY, ROSWELL SABINE (1823-1887), Confederate general, was born at Worthington, Ohio, March 14, 1823. He graduated at West Point in 1843 and entered the artillery service. In the Mexican war he was aide to Gen. G. J. Pillow, and was brevetted for gallantry at Cerro Gordo and Chapultepec. Resigning from the army in 1853, he took up his residence at Charleston, S. C. During the secession movement he was active in the military service of South Carolina, and took part in the siege of Fort Sumter. In May, 1862, he commanded a brigade in defence of Richmond, and he was wounded at the battle of Antietam. He returned to the defence of Charleston, and when that city was evacuated by the Confederates went again to Richmond. After the civil war he resided in Paris for some years, but subsequently engaged in business at Charleston. He died at New York city, March 26, 1887. His history of the *War with Mexico* (2 vols., 1849) is an excellent piece of work.

His uncle, JAMES WOLFE RIPLEY (1794-1870), general, was a native of Connecticut and graduate of West Point. He served in the war of 1812, the Seminole war of 1818, and the Mexican war. He was thereafter connected with the ordnance department until his retirement in 1863, having in August, 1861, been made chief of that department. In March, 1865, he received the brevet of major-general, and he died at Hartford, Conn., March 16, 1870.

RIPON, GEORGE FREDERICK SAMUEL ROBINSON, MARQUIS OF, was born in London, Oct. 24, 1827. He is the only son of the first Earl of Ripon, better known as Viscount Goderich, which title he held while prime minister for a few months in 1827. The marquis succeeded to his father's and uncle's titles in 1859, thus becoming Earl de Grey and Ripon, and in 1872 received his present title as an acknowledgment of his services as chairman of the High Joint Commission which arranged the Treaty of Washington in 1871. He had entered in diplomatic life as attaché at Brussels in 1849, and in 1852 was elected to parliament from Hull, but in the next year stood for Huddersfield and won that seat for the Liberals. In 1857 he was chosen from the West Riding of Yorkshire. In June, 1859, having entered the House of Lords, he was made under-secretary of war; in 1861, under-secretary for India; and in 1863, secretary of war. In 1866 he was made secretary of state for India, and in 1868 lord-president of the council, which office he resigned in August, 1873. In April, 1870, he was installed as grand-master of the Freemasons of England, but in September, 1874, he resigned without assigning any reason. But in a few days it became known that he had been admitted to the Roman Catholic Church at Brompton. When Mr. Gladstone returned to power in 1880, the Marquis of Ripon was appointed viceroy of India. The act called forth much animadversion. The new viceroy's admin-

istration was marked by an endeavor to extend the rights of the natives and to limit the privileges of Europeans. When he departed from India the Hindoo population of Bengal and Bombay testified their regard by extraordinary manifestations. In 1885, when Mr. Gladstone returned to power for a short time, Lord Ripon was made first lord of the admiralty. In 1882 he was chosen president of Yorkshire College, Leeds.

RISTORI, ADELAIDE, Italian tragic actress, was born at Cividale, in Friuli, in 1821. Her parents were actors and brought her on the stage when only four years old. Afterwards she was attached to a dramatic company at Turin and received instruction from Marchioni. At the age of fourteen she was allowed to act the part of Francesca da Rimini in Pellico's drama. In 1841 she removed to Parma, playing chiefly in comedy. In 1846, when she was married to the Marquis Giuliano del Grillo, she retired from the stage at the request of his family. But in 1849 she was induced to appear at Rome for the benefit of one of her former managers and created such a sensation that her relatives allowed her to follow her inclination. She now devoted herself to tragedy, and easily attained the foremost rank on the Italian stage. Her career was interrupted by the siege of Rome, and for a time she was busily employed as nurse in the hospitals. In 1855 she was called to Paris, where Rachel was at the zenith of her fame. Although the French actress bitterly resented the intrusion of the Italian, Ristori's splendid genius soon disarmed the national prejudice, and turned the current of popularity in her favor. For five years she appeared regularly for a season in the French capital. Legouvé's *Medea*, written for Rachel, but refused by her, was translated into Italian for Ristori, and gave her a new triumph. She extended her tours to England, Germany, and Spain with equal success. She passed even to St. Petersburg, Alexandria, Athens, and Constantinople, winning fresh applause. In 1866 she crossed the Atlantic and reaped a rich harvest in the United States. She then visited South America. She played only in Italian, her chief characters being Medea, Mary Stuart, Queen Elizabeth, Francesca da Rimini, Lady Macbeth, Adrienne Lecouvreur. In 1873, after an extended and successful tour in the European capitals, she bade farewell to the English stage, but she visited the United States again in 1875. Later she took up the study of the English language, and in 1882 she appeared in London, and afterwards visited the United States again, acting Lady Macbeth and Queen Elizabeth in English. She is accomplished as an artist, and has the gift of beauty. Her moral character is above reproach, and she is an excellent mother.

RITCHIE, ANNA CORA MOWATT (1819-1870), actress, daughter of Samuel G. Ogden, a New York merchant, was born at Bordeaux, France, and spent her childhood in that vicinity. Soon after her removal to New York she made a runaway match with James Mowatt, a lawyer. Still a child in years, she was pardoned by her parents, and varied the instruction received from her husband with private theatricals and the composition of an epic poem which was published under the title *Phaëto*. Then her husband lost his fortune in speculation and Mrs. Mowatt began to give public readings, though her friends strongly disapproved. Her husband became a publisher and failed again. Determining to try her fortune as an actress, she made her first appearance as Pauline, in *The Lady of Lyons*, in June, 1845. She also appeared in her own plays, *Fashion* and *Arnold*, and achieved success in England as well as America. After the death of her husband, in 1851, she returned to the United States, but continued her professional work until 1854, when she was married to William F. Ritchie. Her *Autobiography of an Actress* (1855) is a graceful narrative of her experience. In 1860 she went to Europe, residing at first on the continent, and afterwards near London, where she died July 28, 1870. Among her later

writings were some novels, *Twin Roses* (1857) and *Italian Life and Legends* (1870).

RITCHIE, THOMAS (1778-1854), journalist, was born at Tappahannock, Va., Nov. 5, 1778. Deprived of his father at an early age, he received an academical education, studied medicine, and taught school, but in 1804 found his proper element in editing the *Richmond Enquirer*. During the forty years of his connection with it as editor and proprietor, it wielded great influence in the Democratic party. In 1845 Ritchie was called to Washington by Pres. Polk to edit the *Union*, as the organ of the administration. He then transferred the *Enquirer* to his sons, Thomas and William. In 1849 he returned to Richmond, and died there July 12, 1854. His son Thomas had died some weeks earlier, but William lived to fight in the Confederate army.

RITSCHL, ALBRECHT, German theologian, was born at Berlin, March 25, 1822. He was educated at the Universities of Bonn and Halle, and taught theology at the former from 1846 until 1864, when he was called to Göttingen, where he still remains. In his early works he belonged to the Tübingen school, but he afterwards took his position on the doctrines of the Lutheran Reformation. His characteristic work is *Die Christliche Lehre von der Rechtfertigung und Versöhnung* (3 vols., 1870-74), translated as *A Critical History of the Christian Doctrine of Justification and Reconciliation*. Other works are *Die Christliche Vollkommenheit* (1874); *Unterricht in der Christlichen Religion* (1875); *Ueber das Gewissen* (1876); *Theologie und Metaphysik* (1881); *Geschichte des Pietismus* (3 vols., 1880-86).

RITTER, FREDERIC LOUIS, musician, was born in Strassburg, Alsace, in 1834. He began the study of music under Hauser and Hans M. Schletterer, later had some instruction from Georges Kastner in Paris, and continued his studies in Germany. In 1852 he received the appointment of professor of music in the Protestant seminary of Fénéstrange, Lorraine, and later conducted a series of concerts at Bordeaux. About 1856 he came to the United States, settling at first in Cincinnati, where he advanced the cause of music in many ways. The Cecilia and Philharmonic societies were organized by him, and many works produced for the first time in America. In 1861 he removed to New York, and in 1867 was appointed professor of music at Vassar College, which position he still (1888) holds. His compositions include a number of instrumental works, many of which have been performed in New York, Boston, and other cities, by the principal orchestras and organizations for chamber-music, some sacred music, and a large number of German songs. He has gained distinction as a writer on musical topics, and is the author of *A History of Music in the Form of Lectures* (Boston, 1870-74; 2d ed., London, 1876); *Music in England* (New York, 1883); *Music in America* (1883); *Manual of Musical History, from the Epoch of Ancient Greece to the Present Time* (1886); and *Musical Dictation* (London, 1888). He edited also *The Realm of Tones* (New York, 1883), and published a *Practical Method for the Instruction of Chorus Classes*, and, with Rev. J. R. Kendrick, *The Woman's College Hymnal* (Boston, 1887). The degree of doctor of music was conferred on him by the University of New York in 1878. He has contributed to this work on "Music in America."

His wife, **FANNY RAYMOND RITTER**, has become well known through her pamphlets on musical subjects: *Woman as a Musician* (New York, 1877); *Some Famous Songs* (London, 1878); *Troubadours and Minnesingers*; *Haydn's "Seasons"* (Poughkeepsie, 1881); and *Madrigals* (1882). She has also written a volume of poems, *Songs and Ballads* (New York, 1888), and has translated Louis Ehlert's *Letters on Music to a Lady* (London, 1877), and Robert Schumann's *Music and Musicians* (London, 1877).

(F. L. W.)

RIVES, WILLIAM CABELL (1793-1868), senator and diplomatist, was born in Nelson co., Va., May 4, 1793. His grandfather, William Cabell (1730-98), was noted as a patriot during the Revolution. Rives graduated at William and Mary College, and studied law with Thomas Jefferson. He volunteered in the defence of Virginia during the British invasion in 1814-15, and was a member of the State constitutional convention in 1816. After service in the State Legislature, and in Congress from 1823 to 1829, he was sent as U. S. minister to France. After his return he was U. S. senator until 1845; was sent again to France in 1849. Retiring then from public life he devoted his leisure to his *Life and Times of James Madison*, of which three volumes were published (1859-69), but the valuable work was never completed. In February, 1861, Rives was member of the peace conference at Washington, but two months later he attended the Confederate Congress. He died near Charlottesville, Va., April 26, 1868. He had published a *Life of John Hampden* (1845), *Ethics of Christianity* (1855), and some minor works. His wife wrote a narrative of her *Residence in Europe* (1842), and other books.

His granddaughter, **AMÉLIE RIVES CHANLER**, author, was born at Richmond, Va., Aug. 23, 1863, and educated by private tutors. She was married in June, 1888, to John Armstrong Chanler, of New York city. She had already become noted by some short stories and poems, and a novel, *The Quick or the Dead* (1888). Her productions have been sharply criticised as both in style and contents a startling mixture of the recondite and sensational.

RIVES, JOHN CABELL (1796-1864), journalist, was born in Kentucky and received but slight education. He became cashier of a bank at Edwardsville, Ill., and in 1824 was appointed clerk in a government office at Washington. He joined Francis P. Blair in founding the *Congressional Globe* for the support of Pres. Jackson's administration. After Pres. Polk established the *Union* as his organ Rives became the sole proprietor of his paper. He introduced the practice of full reports of Congressional proceedings. During the civil war he was liberal in contributions for the cause of the Union. He died near Georgetown, D. C., April 10, 1864.

RIVIERE, BRITON, English painter, was born in London, Aug. 14, 1840. His first studies were pursued under his father, who was a drawing-master in London and Oxford, and he afterwards entered the University of Oxford, and graduated B. A. in 1867. As early as 1858 he had exhibited rural scenes at the National Academy, and among his later pictures are, *Strayed from the Flock* (1866); *The Long Sleep* (1866); *A Midsummer Night's Dream* (1870); *Circe Transforming the Friends of Ulysses* (1871); *Argus* (1873); *Genius Loci* (1874). He had now become recognized as especially successful in pictures of animals, and many of his works have been made familiar by engravings. Among his later works are, *An Anxious Moment* (1878), representing a flock of geese frightened at a hat on the ground; *The Poacher's Widow* (1879); *A Roman Holiday* (1881); *Old Playfellows* (1883); *Actæon* (1884); *The King and his Satellites* (1884); *The Sheepstealer* (1885); *Stolen Kisses* (1886).

RIVINGTON, JAMES (1724-1802), Tory, was born in London, and became a bookseller there. In 1760 he removed to Philadelphia, but soon settled in New York. The *Gazetteer*, which he founded April 22, 1773, was a bitter opponent of the patriotic movements, and on Nov. 23, 1775, the "Sons of Liberty" destroyed its press and melted its type into bullets. Rivington, who had been sent to jail by the Congress, on his release went to England and obtained appointment as King's printer for New York. Returning he commenced in October, 1777, to publish the *Loyal Gazette*, or, as he afterwards called it, the *Royal Gazette*. In 1781, deeming the British cause hopeless,

he began to furnish secret information to Gen. Washington, and after the close of the war he again changed the title of his *Gazette*, but was soon obliged to suspend its publication. He died in New York in July, 1802.

ROACH, JOHN (1815-1887), shipbuilder, was born at Mitchellstown, Ireland, in 1815, and in 1829 emigrated to America. Getting employment in iron-works he became a machinist, and then started a foundry, which afterwards became known as the *Ætna Iron-works*. The demands of the civil war gave him splendid opportunities, and he constructed many large engines. Enlarging his own works, and purchasing others, he engaged largely in construction of iron vessels. In 1871 he purchased shipyards at Chester, Pa., and established the Delaware River iron-shipbuilding and engine-works, which covered 120 acres, while the plant was valued at \$2,000,000. Here he built 63 large vessels for the U. S. government, and for leading steamship lines. When the navy department, in 1885, by a strict construction of contract, refused to accept the despatch-boat *Dolphin* as being too slow, Roach made an assignment, and closed his works. The trouble affected his health, and he died at New York, Jan. 10, 1887. The vessel was subsequently accepted and the works reopened.

ROANOKE COLLEGE is an institution of learning at Salem, Roanoke co., Va. Salem is a town of 2500 inhabitants, on the line of the Norfolk and Western Railroad, 240 miles from Washington and 60 miles from Lynchburg. The Roanoke Valley, in which the college is situated, lies between the Allegheny and Blue Ridge at an average elevation of 1100 feet above the sea-level, and is noted for the fertility of its soil, the healthfulness of its climate, and the picturesque beauty of its scenery.

The germ of Roanoke College was the Virginia Institute, established in 1842 at Mount Tabor, Augusta co., Va. This institution was removed to Salem in 1847, Rev. C. C. Baughman being principal. In 1853 it was chartered by the Legislature of Virginia as Roanoke College. Rev. David F. Bittle, D. D., was elected first president, and served with untiring energy for 23 years. Rev. Thomas W. Dosh, D. D., served as president during the sessions of 1877-78. Since that year the present incumbent, Julius D. Dreher, A. M., Ph. D., a graduate of the college (class of '71), has held the office. Prof. S. C. Wells, A. M., Ph. D., senior member of the faculty, dates his connection with the institution to the year 1849, when he was elected first assistant teacher in the Virginia Collegiate Institute. Rev. Wm. B. Yonce, A. M., Ph. D., next oldest professor, was elected tutor in 1854. The college owns 20 acres of land well situated in Salem, the campus proper being very attractive. There are four large brick buildings for college purposes, the entire front being 313 feet. A separate building—Bittle Memorial Hall—was erected in 1879 for the accommodation of the library, which now contains 16,000 volumes, including many rare and valuable works. The college owns a collection of more than 12,000 mineralogical and geological specimens, a numismatic cabinet, and valuable chemical and philosophical apparatus.

The board of trustees has power to hold property, elect professors, prescribe courses of study, and confer degrees. The college offers to candidates for degrees a choice among the following courses of study: 1. Ancient classical course, with degree of Bachelor of Arts. 2. Modern classical course, with degree of Bachelor of Arts. 3. Scientific course, with degree of Bachelor of Science. In these courses the instruction is thorough and practical. In mathematics, students have practical field-work, and learn the use of instruments; in chemistry and natural philosophy there are frequent experiments; in geology, excursions. French and German are spoken in the classroom. The course in both French and German extends through three years.

The college was in operation throughout the war, but up to 1865 had graduated only 41 men. Its main results have been accomplished almost entirely within a later period, under many disadvantages, and with very inadequate means. The whole number of graduates is now nearly 300, the majority of whom are engaged as professors, teachers, clergymen, lawyers, and physicians. Graduates of the college may be found in 28 States and Territories, and in two foreign countries. Many students at the South pursue only a partial course at college; of this class Roanoke has received fully 1500. The college draws its students from nearly every Southern State, and from some parts of the North and West. The first Mexican to complete the course of study received his diploma in the class of 1888. For 18 years Roanoke has been educating Indians. The Choctaws support a small number of students at the college at the expense of their government. Three Choctaw superintendents of schools have visited the college in the discharge of their official duties. In 1883 Wm. H. McKinney graduated at Roanoke with the degree of A. B., being the first Indian to take a diploma at a Virginia college, and also the first one to win that honor at Yale University, where he was made a bachelor of divinity in 1886. The number of students in attendance in 1888-89 is nearly 150, coming from 14 States, Indian Territory and Japan. The students maintain two excellent literary societies. There is also an alumni association composed of the graduates. A General Reunion Association embracing former students, as well as graduates, holds triennial reunions at the college during commencement week. The college has always been noted for its high moral tone and its positive but not sectarian religious character. An active Young Men's Christian Association exerts a strong influence on the moral life of the college. Candidates for the ministry and sons of clergymen pay only half the regular tuition fee. The entire expenses of a student for a session of nine months range from \$150 to \$205. The faculty endeavor to aid young men of small means in availing themselves of the advantages afforded by the college. The *Roanoke Collegian*, the organ of the graduates and students, is published monthly during the session. Prof. F. V. N. Painter, A. M., of the faculty, has published a *History of Education* (1885). (J. U. D.)

ROBBINS, THOMAS (1777-1856), antiquary, was born at Norfolk, Conn., Aug. 11, 1777. He was of a family which contained many Puritan preachers of local note. He graduated at Yale College in 1796 and was pastor successively at East Windsor, Stamford, and Rochester, Mass. In 1842 he took up his residence at Hartford and founded the Connecticut Historical Society, to which he bequeathed his valuable library. An early series of articles from his pen was collected under the title *First Planters of New England* (1815). He also published *View of all Religions* (1824) and some other works. He died at Colebrook, Conn., Sept. 13, 1856. A bulky biography of him was published (1887).

ROBERTS, BENJAMIN STONE (1811-1875), general, was born at Manchester, Vt., graduated at West Point in 1835, and was first lieutenant of dragoons when he resigned in 1839 to become railroad engineer in Northern New York. He was afterwards assistant geologist of that State and in 1842 went to Russia to assist in railroad construction. In 1843 he settled in Iowa and engaged in the practice of law, but the outbreak of the Mexican war called him to arms again. He was made first lieutenant of mounted rifles, and distinguished himself at Chapultepec and Matamoros. He was a major of cavalry serving in New Mexico when the civil war broke out and soon was engaged in defending Fort Craig against Texans under Sibley. In June, 1862, he went to Washington and was made brigadier-general and chief of cavalry in Gen. Pope's army. With that commander he was afterwards sent to Minnesota, but in June, 1864, he had command of

a division in Louisiana, and afterwards in West Tennessee. He retired from the army in July, 1866, and died at Washington, Jan. 29, 1875.

ROBERTSON, JAMES (1742-1814), pioneer, was born in Brunswick co., Va., June 28, 1742, and was brought up on his father's farm. In 1759 he accompanied Daniel Boone on his third expedition across the Alleghenies and discovered the Watauga Valley. Next spring he led a band of settlers there and arranged with the Cherokees a treaty on terms of which the whites and natives lived at peace till 1776. Troubles then broke out, but Robertson succeeded in subjugating the red men, and, at the instance of the governor of North Carolina, took up his residence at their capital in order to keep them in check. In 1779 he removed with a number of the Watauga settlers to the region of the Cumberland, where on Christmas of that year they founded Nashville, and organized themselves into a civil and military body with Robertson at their head. Their conflicts with the savages who swarmed around them were almost incessant. In 1781 the fort of Nashville was besieged by 1000 Indians and Robertson's life was saved by his wife. Notwithstanding severe losses by the tomahawk and desertion, Robertson maintained the settlement. During the Revolutionary war he supported the patriot cause, and on being later urged by the Spaniards, with the promise of many advantages, to establish an independent government west of the Alleghenies, he refused their offer. In 1790 he was made by Washington a brigadier-general and, as such, commanded the Tennessee militia. During his later years he was U. S. agent to the Chickasaw Indians, and died at the Chickasaw Agency, Tenn., Sept. 1, 1814. See A. W. Putnam's *Life and Times of Robertson* (1859), and J. R. Gilmore's *Advance-Guard of Western Civilization* (1888).

ROBIN, CHARLES PHILIPPE (1820-1885), French physician and naturalist, was born at Jasseron, June 4, 1820. He studied medicine at Paris and in 1845 was employed in an exploration of the coasts of Normandy and Jersey for enriching the museum of natural history and comparative anatomy in the Paris École Pratique de Médecine. He obtained the doctor's degree in 1847, and was made professor of histology in 1862. His works relate to comparative anatomy, physiological chemistry, and parasitism. With M. Littré he thoroughly revised Nysten's *Dictionnaire de Médecine*. With M. Verdeil he published *Histoire Naturelle de Végétaux Parasites* (3 vols., 1853). Among his other works are *Les Substances Organisées* (1866); *Les Humeurs du Corps de l'Homme* (1867); *Anatomie Microscopique* (1868). In 1871 he assisted in founding a sociological society.

ROBINSON, EZEKIEL GILMAN, President of Brown University, was born at Attleborough, Mass., March 23, 1815. He graduated at Brown University in 1838 and at Newton Theological Institution in 1842. He was ordained pastor of the Baptist church in Norfolk, Va., in 1842, and in 1846 was called to the theological seminary at Covington, Ky., as professor of Hebrew. He afterwards had charge of a church in Cincinnati, but in 1852 was made professor of Biblical theology in the Baptist Seminary at Rochester, N. Y., of which he became president in 1860. While holding this position he was also editor of the *Christian Review* for six years. Since 1872 he has filled with ability the presidency of Brown University.

ROBINSON, HENRY CRABB (1775-1869), best known by his entertaining *Diary and Correspondence*, published posthumously, was born at Bury St. Edmund's, England, May 13, 1775. He studied law and at the age of twenty-five went to Germany, where besides attending some of the principal universities he associated with the most eminent literary men, including Goethe and Schiller. When the Peninsular war began in 1808 Robinson wrote letters from Spain to the *London Times*, and afterwards in England was

an editorial contributor. At the age of thirty-eight he was called to the bar and for fifteen years practised his profession with diligence and success. In later life he was active in promoting the London University and other institutions for the benefit of art and literature. His *Diary and Correspondence* (1869) is filled with pleasant gossip and graphic sketches of prominent men with whom he came in contact. He died at London, Feb. 5, 1867.

ROBINSON, STUART (1816-1881), Presbyterian minister, was born at Strabane, Ireland, Nov. 26, 1816, but in early life he was brought to America. After graduating at Amherst College in 1836, he studied theology at Union Seminary, Va., and at Princeton. He held pastorates in Virginia, Kentucky, and Baltimore and edited the *Presbyterian Critic*, in which he maintained High Church views of Presbyterian polity and doctrine. In 1856 he was called to the Danville Theological Seminary as professor of ecclesiology, but in 1858 he removed to Louisville, where he edited the *True Presbyterian* and also ministered to a church. During the civil war his paper was suppressed by the Union authorities, but it was afterwards allowed to appear under the name *Free Christian Commonwealth*. He was the leader of the Louisville Presbytery and in 1866 was expelled from the General Assembly which met at St. Louis for signing the "Declaration and Testimony," which censured that body for making political deliverances. He afterwards induced the Synod of Kentucky to withdraw from the Northern Church and join the Southern. In 1869 he was elected moderator of the Southern General Assembly by acclamation. He died at Louisville, October 5, 1881. His most important works are *The Church of God* (1858), and *Discourses of Redemption* (1866). Several of his pamphlets related to controversies between the Northern and Southern Presbyterians.

ROBY, HENRY JOHN, an English educator, was born at Tamworthy, Aug. 12, 1830. He was educated at Bridgnorth and at St. John's College, Cambridge, graduating in 1853, and being made fellow of the college in 1854, and tutor in 1855. He took part in the movement for university reform and published a pamphlet on the subject. In 1861 he was made under-master of Dulwich College Upper School, and in 1866 professor of jurisprudence at University College, London. He was appointed secretary of the schools inquiry commission in 1864, and to the endowed schools commission in 1869, and was a member of the latter 1872-74. He has since been engaged in business at Manchester. Besides preparing the *Report of the commissioners* and editing several volumes connected with it, he published an excellent *Grammar of the Latin Language, from Plautus to Suetonius* (2 vols., 1871-74).

ROCHAMBEAU, JEAN BAPTISTE DONATIEN VIMEUR, COMTE DE (1725-1807), a French general noted for his services in the American Revolution, was born at Vendôme, July 1, 1725. Entering the army at the age of sixteen, he served in Germany under Marshal Broglie and in 1745 became aide to the Duke of Orleans. He had reached the grade of lieutenant-general when in 1780 he was sent with 6000 men to the United States. He arrived at Newport in July and after fortifying Rhode Island he acted in concert with Washington against Clinton in New York. In the next year he went to Virginia and rendered important service, resulting in the capture of Cornwallis at Yorktown, Oct. 19, 1781. Two captured cannons were presented to Rochambeau. Returning to France he received the decoration of Saint Esprit, and was made governor of Picardy and Artois. In 1791 he was made a marshal of France, but his conduct in command of the Army of the North disappointed public expectation and he narrowly escaped the guillotine. Thenceforth he lived in retirement, but Bonaparte in 1804 conferred on him a pension and the grand cross of the Legion of Honor. He died May 10, 1807. His *Me-*

moires were published in 1809 and translated into English in 1838.

His son, DONATIEN MARIE JOSEPH DE VIMEUR, VICOMTE DE ROCHAMBEAU (1750-1813), became a general in the French service and was chiefly employed in Santo Domingo, of which he became governor in 1802. On his return voyage in the next year he was captured by the English and remained prisoner nearly eight years. He was killed at the battle of Leipsic, Oct. 18, 1813.

ROCHEFORT, HENRI, French journalist and politician, discards the title "Marquis de Rochefort-Luçay" to which his birth entitled him. He was born at Paris, Jan. 30, 1830, and early adopted the republican views of his mother rather than those of his royalist father. Before devoting himself to journalism he had studied medicine and had been in employ of the municipality of Paris. He also composed many popular plays and vaudevilles, as his father had done before him. To the journals of Paris he contributed for some years art and dramatic criticisms and social sketches. While connected with the *Figaro* he gradually turned from social topics to caustic satire of the imperial administration. These sketches were collected into three volumes, *Les Français de la décadence* (1866-8). Obligated to leave the *Figaro*, Rochefort founded the famous *Lanterne*, of whose first number 80,000 copies were issued. After eleven weekly numbers had been published, the proprietor was brought before the tribunals, and sentenced to fine and a year's imprisonment. But he had fled to Belgium, where he continued to edit the offensive paper, which was still circulated in France in spite of vigorous efforts of the police for its suppression. In 1869 he was twice a candidate for the Chamber of Deputies, and having been elected he braved the sentence of imprisonment and proceeded to Paris. Napoleon III. granted him a safe-conduct, which Rochefort accepted, though many of his supporters had hoped for a collision with the authorities. He now founded *La Marseillaise*, whose attacks on the imperial family provoked Prince Pierre Bonaparte to kill Victor Noir, one of Rochefort's assistants. In January, 1870, the journal was seized and the proprietor was sentenced to six months' imprisonment. The catastrophe of Sedan restored him to liberty and gave him a place in the government of national defence. He kept aloof from the Communists, but tried to induce the government to make some concessions to them. When this was not done he resigned his office, though he still had charge of the barricades. In February, 1871, he founded *Le Mot d'Ordre*, and was elected deputy. He instigated some of the worst excesses and outrages of the Communists. Arrested at Meaux, May 20, he was sent to Versailles for trial, and in September was condemned to imprisonment in a fortress. Victor Hugo interceded for him with Pres. Thiers, but in vain. His friends declared that his mind was shattered and his death at hand. He was permitted to leave the prison in order to be married to Mile. Renaud, who had borne him several children. In 1873 he was transported to New Caledonia, but some months later he escaped to an American vessel and was taken to San Francisco. Thence he made his way to Geneva, where he resided until the general amnesty of 1880 permitted his return to Paris. There he established in opposition to Garibaldi's policy of opportunism a new journal, *L'Intransigeant*. In recent years less attention has been paid to his utterances on public questions.

ROCHESTER, a city of Minnesota, county-seat of Olmsted co., is on the Winona and St. Peter Railroad, 75 miles S. E. of St. Paul. It is also on the Zumbro River, which is spanned by three iron bridges, and furnishes water-power for three flour-mills. Cokle-separators (see Vol. III, p. 95) are manufactured here, as well as wagons, furniture, and agricultural implements. There are also several foundries. The largest building is the Insane Hospital, erected at a cost of \$325,000,

and having capacity for 700 patients. Besides the city high-school, which cost \$75,000, there are other schools, including a Roman Catholic seminary. The total valuation of property is \$1,750,000 and there is a public debt of \$18,000. The city was incorporated in 1858. In 1883 a destructive cyclone levelled the lower town, causing the death of 27 persons. That portion of the city has since been rebuilt. The population by the State census of 1885 was 5313.

ROCHESTER, a flourishing city of New York, the seat of Monroe co., is on both banks of the Genesee River, 7 miles from Lake Ontario. The city is about 250 ft. above the level of Lake Ontario, and the river has here three falls, of 96 ft., 26 ft., and 83 ft., respectively, which afford immense water-power, abundantly utilized in all kinds of manufactures. At the Upper fall the New York Central Railroad crosses the city, and it has here three branches. The other main railroads are the Erie; the Buffalo, Rochester, and Pittsburg; the Buffalo, New York, and Philadelphia; the West Shore; and the Rome, Watertown, and Ogdensburg. There are short roads to Lake Ontario and to Brighton River. The Erie Canal crosses the river by a stone aqueduct, 850 ft. in length, and supported by 7 arches. Among the public buildings are the city-hall, court-house, which are also surrounded by buildings of fine architecture. There are also the spacious city-hospital, St. Mary's Hospital, county-jail, arsenal. Among the 75 churches are several of fine architecture, including the First Baptist, First Presbyterian, St. Peter's, and the Roman Catholic Cathedral. There are many charitable institutions, including orphan asylums, homes for the friendless, and church homes. The University of Rochester, which is under control of the Baptist denomination, has handsome buildings and grounds, comprising 23 acres. The Baptist Theological Seminary has a fine 4-story brick building. The public school system comprises 31 schools of various grades, including the Free Academy. There are also 44 private and parochial schools, the chief of which is St. Andrew's Seminary. A public library connected with the public schools, the Athenæum, has a large library and reading-room, and the Law Library in the court-house is of great value. The State has a House of Refuge for juvenile delinquents, there being separate buildings for males and females. The grounds cover 42 acres and there are accommodations for 500 boys and 200 girls. The object of this institution is to reform the inmates and train them in morality and industry. Near the city are also Monroe county penitentiary, the almshouse, and insane asylum, which have well-constructed buildings.

The city has an excellent supply of water for drinking and fire purposes. It is derived partly from the river and partly from Hemlock Lakes, nearly 30 miles south. The receiving reservoir has a capacity of 85,000,000 gallons, and the distributing reservoir a capacity of 45,000,000. There are two gas companies, one on each side of the river. There are 9 hotels, 3 national banks, 8 other banks, 7 daily and 4 weekly newspapers. The leading industry during the most of the city's history was flour manufacture, and this is still extensively carried on. There are 11 iron-foundries, iron-bridge-works, cotton-factories, and manufactories of clothing, boots and shoes, furniture, cigars and tobacco, India-rubber goods, carriages, glass, perfumery, agricultural machinery, steam-engines, etc. There are large breweries, fruit-canning establishments. Coal is largely distributed from this port to other places on the Lakes. The fertility of the Genesee Valley has greatly contributed to the prosperity of Rochester, and the nursery business is extensively carried on. The city was settled about 1810, and incorporated in 1832. Its property is valued at \$75,514,275; the public debt is \$5,515,000, and the expenses for the year 1886 were \$1,123,460. The population in 1880 was 89,366.

ROCHESTER UNIVERSITY OF. The movement to establish a University at Rochester originated

with prominent Baptists of the State of New York, and first took definite shape in an effort to remove Madison University from Hamilton, N. Y., to Rochester. An organization was first effected Sept. 16, 1850, under a provisional charter granted by the Board of Regents, at which time the trustees elected the usual officers, appointed an executive committee consisting of 9 members of their own body, created 6 professorships, and adopted a course of instruction. No president was elected. The actual work of instruction began on the first Monday in November, 1850. The first catalogue reported 8 instructors and 71 students. In July, 1851, a class of 10 was graduated. On Feb. 14, 1851, a permanent charter had been granted by the Regents which vested the control of the institution in a self-perpetuating Board of Trustees—24 in number—holding office for life, and which conferred upon the institution "all the privileges and powers conceded to any college in this State."

The executive duties of the president were performed by Dr. A. C. Kendrick, the eminent Greek scholar and exegete, who had been elected to the chair of the Greek language and literature. Coming from Madison University with a reputation already established, he gave to Rochester for over thirty years the full strength of his splendid powers, and, with the exception of Pres. Anderson, has been more completely identified with the history of the University than any other member of its faculty. On April 6, 1853, Martin B. Anderson, of New York, then editor of the *New York Recorder*, the leading paper of the Baptist denomination, was elected president of the institution, and entered upon his duties in the fall of the same year. To no one man does the University of Rochester owe so much as to Pres. Anderson. His moulding and shaping influence has been constant and pre-eminent in all the factors of substantial growth, notably in the development, expansion, and organization of the course of study, methods of instruction and discipline, and the characteristic features referred to below.

One of the most potent influences in determining the organization and location of the institution was the fact that the wealthy and populous district known as Western New York, with a population as early as 1850 of half a million, was at that time almost wholly wanting in facilities for higher education. This region contains the immediate constituency of the University; but it has always drawn a considerable percentage of its students from the country at large, and its last catalogue (1887-88) shows that 11 States and Territories, as well as Germany and England, are represented among its students.

The founders of the University acted from the deep-seated conviction that higher education should be distinctively Christian—carried on under influences which would tend to develop and strengthen the moral and religious life. Most of them were Baptists, and this denomination has always controlled the institution, 20 out of 24 members of the first Board of Trustees being connected with it. The movement was, however, not sectarian in any exclusive sense. From the first, the enterprise enlisted the hearty and effective co-operation of eminent citizens of other denominations, and such have been among its most munificent benefactors. Its spirit, management, and instruction have been entirely free from sectarian influence. Other denominations are liberally represented in its board of trustees and faculty of instruction, while students of all faiths, including Catholics and Jews, freely avail themselves of its privileges.

The limits of this article forbid any but the briefest reference to its numerous benefactors. The list of those who have contributed \$5000 or upward to its various purposes includes over 30 names. A much larger number have given smaller sums, while many have given business or professional services invaluable to the institution. Full information regarding the men who have founded, endowed, and administered

the institution may be found in Gilmore's *Outline History of the University of Rochester*.

The University has been characterized by steady growth in all the features which give strength and stability to such an institution. It began its work in 1850 in rented quarters in an old hotel. It now owns a beautiful campus of 23 acres on which are situated 3 large, costly buildings, amply providing for a library of over 23,000 volumes, one of the best and most complete geological and mineralogical collections in the country, consisting of over 40,000 specimens, chapel and lecture-rooms, and a chemical laboratory new and complete in all its appointments. The value of property and endowment has grown from \$13,000, the amount raised at the organization of the University, to very nearly \$1,000,000. The faculty has been nearly doubled in numbers and now consists of 12 members, while the courses of instruction have been more than doubled in scope.

There are several features which distinguish the University of Rochester from most other colleges and some which are peculiar to it. Among the former may be mentioned the absence of dormitories, which are rendered entirely unnecessary by the ample accommodations furnished to the students in private families. Among the former is a system of "Honor courses," which include a wide range of studies supplementing and extending the regular curriculum, and designed to develop to the utmost the capacity for independent study and investigation. They are open to all students who attain a certain standing in the regular course. In most of them regular instruction is given, and they all terminate in a written examination, entitling the student to honorable mention, if successfully passed. Another feature consists in Saturday morning lectures, affording every student supplementary instruction for one hour per week throughout the course, and including elocution and composition, the Greek, Roman, French, and German literatures, historical geography, comparative philology, chemical physics, embryology, sanitary science, and history of art and principles of æsthetic criticism.

Pres. Anderson introduced at the beginning of his administration a feature which he called "chapel talks," consisting in the brief discussion before the whole body of students of questions suggested by the events of the day, especially with a view to pointing out their significance, and exhibiting the historical, social, and ethical principles involved.

The University of Rochester exists primarily to give, under Christian influences, that general and liberal culture which is felt to be essential to the highest success in life, and to be the best preparation for special and professional study. In the establishment and modification of the curriculum, therefore, the aim has been to secure a natural, logical order of studies; thorough, continuous discipline; and the greatest possible symmetry of culture by grounding the student in the fundamental principles of all the great departments of human knowledge. Election of studies is permitted to a limited extent in the junior and senior years, and even earlier when such election will not interfere with the objects above mentioned. Of the scope of instruction Pres. Anderson says: "The organic law of the University is such as to give free play to all the elements in education which modern progress has developed. In our curriculum we have retained the studies which the world's experience has tried and proved, and welcomed all new subjects whose promise justified trial;" and he has further defined the end which the institution seeks to attain for the student as: "The foundation of correct moral and intellectual habits through the scientific comprehension of specimen portions of the field of organized knowledge."

Of these Pres. Anderson says: "The true aim of the teacher is to give breadth, culture, elevation, and power to the minds of his pupils. This aim we have set before ourselves in this institution. Each instructor

is expected to bring before his classes the results of original thought and independent investigation, and instead of a mere *memoriter* recitation, the student is trained and encouraged to raise questions and suggest difficulties. We have sought to make our instruction at once historical, comparative, scientific, practical, and personal."

The alumni of the university now number about one thousand, and nearly as many more have taken partial courses. Of the alumni over 200 have entered the Christian ministry, about 160 have studied law, 30 have studied medicine, 12 have become journalists, while more than one hundred have made teaching their life-work. Of the teachers, above 50 per cent. have become professors in or presidents of colleges or professional schools.

At the close of the college year 1887-8 Rev. M. B. Anderson, D. D., retired from his work as president, and Rev. David J. Hill, D. D., LL. D., who had already discharged with conspicuous ability the duties of president in the Bucknell University, Lewisburg, Pa., was chosen his successor. (G. M. F.)

ROCKFISH, the common name given to *Roccus lineatus*, a member of the family *Percidae*, which is known also as the Striped Bass, and extends from the Gulf of St. Lawrence to the Gulf of Mexico. From the New Jersey coast northward it bears the name of striped bass, but is called rockfish in the Delaware River and southward. It is a strong, active, and voracious fish, which annually ascends the rivers to spawn, and remains in them through a considerable portion of the season. It is non-migratory, being found on the coast summer and winter, and caught in all the rivers of the Eastern United States. Great numbers are taken during the winter in Chesapeake Bay and its tributaries. In the rivers of New Brunswick it is taken in abundance in the winter by spearing through the ice.

At the time of the spring run of the shad the rivers are well supplied with rockfish, which are then plump and well fed, preying on the small river fishes. The rockfish is said to lay as many as 2,250,000 eggs. The young grow very rapidly, the mature fish attaining a weight of 20 lbs., though individuals of 50 lbs. have been caught, and there is record of one weighing 112 lbs. The rock is one of our most valuable food-fishes, the flesh being firm and of fine flavor. As a game-fish it ranks next to the salmon in popularity. It was formerly very abundant in the waters of Cape Cod Bay, but has been greatly reduced there, though not evidently so farther south, from which region great quantities are annually sent to market. It is taken largely in the shad seines in the spring. It was introduced by the U. S. Fish Commission into the waters of California some years ago. A related species, *R. labrax*, is an important European fish. There are three other North American species of *Roccus*, of which *R. americanus*, the white perch, is a favorite pan or frying fish.

Fishes of several other families are known as rockfish, this name being given in Bermuda to all the species of the subgenus *Myxeteropercæ*, which are large and important food-fish. The log perch, *Percina auroprodes*, little perch-like fresh-water fishes, are also known as rockfish. On the Pacific coast fishes of the family *Scorpenidae* are commonly known as rockfish and rock-cod. They are enormously abundant, of large size and brilliant color, and are caught largely, all the species being excellent food-fish. In average size they are about 15 inches long, and 2 or 3 lbs. weight, and their rich and attractive hues give great brilliancy of color to the San Francisco fish-stalls. (C. M.)

ROCKFORD, a city of Illinois, the seat of Winnebago co., is on both sides of Rock River, 91 miles W. of Chicago, on branches of the Chicago, Burlington, and Quincy, the Chicago, Milwaukee, and St. Paul, the Chicago and Northwestern, and the Illinois Central Railroads. Three railroad bridges and one wagon

bridge cross the river. The principal buildings are the court-house and other county buildings, opera-house, and high-school. There are 7 hotels, 4 national banks, 1 private bank, 2 daily and 4 weekly newspapers, 20 churches, 12 schools, a female seminary, and a business college. The industrial works comprise 2 flouring-, 2 paper-, 1 woollen-, and 1 cotton-mill, and many factories, producing agricultural implements, boots and shoes, furniture, watches, silver-plated ware, cutlery, bolts, churns, carriages, pumps, culinary extracts, wood-engravings, knit-goods, clothing, and soap. The city is well built, has wide, well-shaded streets, and two parks. It is lighted with gas and electric light, and is supplied with water by the Holley system. It was settled in 1834, and in 1880 had 13,129 inhabitants, while the State census of 1886 gave 19,420.

ROCK ISLAND, a city of Illinois, seat of justice of Rock Island co., is on the Mississippi River, nearly 3 miles above the mouth of the Rock River. It is 181 miles west of Chicago. A fine wrought-iron bridge, built by the U. S. government in 1870, at a cost of \$1,300,000, connects Rock Island with Davenport, Iowa. On the island which gives name to the city the government has erected a vast armory and arsenal, and expended large sums of money in its improvement. The navigable channel of the river is west of the island, while that on the east has been dammed, and furnishes immense water-power. The city has a court-house, 3 national banks, 20 churches, a high-school and other schools, and is the seat of Augustana College, which is under the patronage of Swedish Lutherans. The industrial works comprise saw-mills, flour-mills, machine-shops, stove-foundries, glass-works, and other manufactories. The city was incorporated in 1849, and in 1880 it had 11,659 inhabitants.

ROCKLAND, a city of Maine, is on the west side of Penobscot Bay, 10 miles from the ocean, and 60 miles E. N. E. of Portland, with which it has railroad connection. It has a U. S. government building of granite, a court-house of brick and granite, 2 national banks and other banks, 10 churches, graded schools, a public library, and 3 weekly newspapers. The water-supply is from a lake, 2½ miles distant. Rockland has an iron-foundry, brass-foundry, and minor manufactures. The chief articles of export are lime and granite, the latter being obtained from the neighboring islands. The town was incorporated in 1848, and received a city charter in 1854. Its population in 1880 was 7599.

ROCKVILLE, a manufacturing village of Tolland co., Conn., is on the New York and New England Railroad, 17 miles N. E. of Hartford, and 4 miles from Vernon, from which a branch road runs. Hoekanum River, the outlet of Snipsic Lake, gives abundant water-power, having here a fall of 280 feet. There are 5 woollen-mills, and factories producing cotton goods, spool-silk, and stockinets. There are 3 hotels, an opera-house, 2 national banks, 2 savings banks, 8 churches, a high-school and other public schools, and 2 weekly newspapers. It is lighted with gas, and supplied with water by aqueduct from the lake. It is part of the town of Vernon, which was organized in 1808. Its first church was built in 1838. Its population in 1880 was 5902.

RODES, ROBERT EMMETT (1826-1864), Confederate general, was born at Lynchburg, Va., March 29, 1826. He graduated at the Virginia Military Institute in 1848, and was afterwards made instructor there. He went to Mobile, Ala., early in 1861, to become captain of cadets, and on the outbreak of the civil war was made colonel of the Fifth Alabama regiment. He was soon promoted to brigadier-general, and in 1862 was wounded at Seven Pines and at Antietam (Sharpsburg). He fought also at Fredericksburg and Chancellorsville, gaining at the latter his promotion to a major-generalship. He fought at Gettysburg, and was afterwards with Gen. Jubal A. Early in the Shenan-

doah Valley. He was killed in battle at Winchester, Va., Sept. 19, 1864.

RODGERS, JOHN (1771-1838), commodore, was born at Havre de Grace, Md., July 11, 1771, and entered the U. S. navy in 1798 as lieutenant. He was with Com. Truxton on the Constellation, when he captured the French frigate *L'Insurgente* in February, 1799. Being then made captain, he cruised in the West Indies, and in 1802 went to the Mediterranean. In June, 1803, he made a successful attack on the Tripolitan fleet, and in 1804 had command of the Congress (38 guns). In 1805 he succeeded to the command of the fleet, and brought the wars with Tripoli and Tunis to a close. In 1811, while commanding the President, a 44-gun ship, he engaged in pursuit of a British vessel which had impressed an American sailor off Sandy Hook. On his coming up with the *Little Belt* (22 guns), Capt. Bingham, an engagement ensued, in which the British vessel was crippled. The two captains give varying accounts of the origin and progress of the fight. Although war between the two nations was averted for a time, the action greatly increased the hostile feeling. At last, in June, 1812, Rodgers sailed from New York in command of a squadron, but two days later, while he was chasing a British frigate, a gun burst, wounding him and others, and killing some. In the same year he captured some British merchant vessels. In 1814 he was employed in the defence of Baltimore. After the war he was president of the board of navy commissioners until 1837, with the exception of the years 1824-27, when he commanded the Mediterranean squadron. He retired in 1837, and died at Philadelphia, Aug. 1, 1838.

His son, **JOHN RODGERS** (1812-82), rear-admiral, was born in Maryland, Aug. 8, 1812, and became a midshipman in 1828. In 1853-56 he commanded the steamer *John Hancock* in an exploring expedition in the North Pacific. At the outbreak of the civil war he had risen to the rank of commander, and early in 1862 he superintended the construction of the iron-clads for service on the Mississippi. In May he conducted an expedition of gun-boats on the James River, and attacked Fort Darling. In June, 1863, with the monitor *Weehawken*, he captured the Confederate iron-clad *Atlanta* near Savannah, Ga., after a very brief contest. For this exploit he was made commodore. In 1866 he made the perilous voyage around Cape Horn in the monitor *Monadnock*. In 1869 he was promoted rear-admiral and had command of the China fleet. In August, 1871, he captured the Korean forts, and put an end to the outrages which Koreans had committed on American commerce. He afterwards had charge of Mare Island navy-yard at San Francisco. He was made superintendent of the U. S. Naval Observatory at Washington, in 1877, and in the next year became also chairman of the Lighthouse Board. He was noted for his scientific attainments and did much to promote scientific work by the national government. He died May 5, 1882.

RODMAN, THOMAS JEFFERSON (1815-1871), inventor, was born at Salem, Ind., July 30, 1815. He graduated at West Point in 1841, and entered the ordnance department. His chief invention was a method of casting guns hollow and cooling them from the inside. For its results, and the comparative merits of his guns, see **ORDNANCE**. He also introduced the use of mammoth powder, and was constantly engaged in making and testing devices for the improvement of ordnance. During the civil war his guns were used by the navy as well as the army, and the method of cooling from the inside was applied to shells. Rodman had command of the Watertown arsenal during the war, and in June, 1863, was made major, and at the close of the war received the brevet of brigadier-general. In 1865 he was placed in command of Rock Island, where he constructed the arsenal. In 1867 he was promoted lieutenant-colonel. He died at Rock Island, June 7, 1871.

RODNEY, CÆSAR (1728—1784), a signer of the Declaration of Independence, was born at Dover, Delaware, Oct. 7, 1728. From his grandfather, William Rodney, an early settler of that State, he had inherited a large estate. In 1750 he was sheriff of Kent co.; for many years he was a member of the colonial assembly, and its speaker from 1769 to 1774. Here he zealously advocated a measure forbidding the importation of slaves, which was negatived by only two votes. In 1765 he was sent as a delegate to the Stamp-act congress at New York, and, on repeal of the obnoxious act, was one of three commissioners appointed to prepare an address of thanks to the king. When the tax on tea was proposed in the British Parliament of 1767, he was again one of three to frame an address to the king, in which resistance to oppression was foreshadowed. When the colonies entered into correspondence regarding common defence, Rodney became president of the Committee of Safety for Delaware. In 1774 popular meetings were held at Dover and Newcastle to demand the assembling of a convention, whereupon he, as speaker, summoned the representatives of the people to meet at Newcastle Aug. 1. Here he was made chairman, and he was further sent as a delegate to the Continental Congress of that year, where he was on the committee that drew up a statement of the colonies' grievances and rights. In 1775 he was re-elected to the Congress, and made at first colonel, and then brigadier-general, of the State militia. In 1776 he was constantly employed in patriotic activities. Being warned by friends, when the vote on the Declaration was imminent, he rode with all speed to Philadelphia, and was the means of casting Delaware's vote for independence. Failing in re-election to Congress, he went directly to Trenton, where Lord Stirling made him post-commander, but soon left to join Washington at Morristown. Returning home in 1777, he suppressed an insurrection in Sussex, and, when the British advanced into Delaware, he put himself at the head of some militia and annoyed the enemy's flank, with the view of cutting them off from their fleet. For his services here he was promoted major-general. In December he was re-elected to Congress, but did not take his seat, owing to his having been, in the meantime, chosen President of Delaware, a post he held for four years. In 1782 and in 1783 he was re-elected to Congress, but on both occasions declined, as he had done re-election to the presidency of Delaware in 1782. He had long suffered from cancer of the face, and died from it at Dover, June 20, 1784.

His nephew, **CÆSAR AUGUSTUS** (1772—1824), statesman, was born at Dover, Delaware, Jan. 4, 1772. He graduated at the University of Pennsylvania, studied law, was admitted to the bar in 1793, and practised in Wilmington. From 1803 to 1807 he was a prominent member of Congress, taking Jefferson's side, and from 1807 to 1811 he was U. S. attorney-general, under both Jefferson and Madison. During the war of 1812 with England he commanded an artillery corps which served on the Canadian frontier. In 1817 he went to South America as a member of the commission to report upon the propriety of recognizing the newly formed Spanish-American republics, which course he strenuously advocated. In 1821 he returned to Congress, and in 1822 was made U. S. senator. In 1823 Rodney was appointed minister to the Argentine provinces, and while discharging the duties of this position died at Buenos Ayres, June 10, 1824. With J. Graham he published *Reports on the United Provinces of South America* (London, 1819). His memory is still highly cherished in the Argentine Republic for the excellent counsel and other aid which he rendered at a critical time.

ROE, EDWARD PAYSON (1838—1888), author, was born at Windsor, N. Y., March 7, 1838. From his father he inherited a taste for horticulture which clung to him through life. He studied at Williams College with a view to the ministry, and after a year at Auburn

Theological Seminary became in 1862 chaplain of the Second New York Cavalry, whence he was transferred by Pres. Lincoln to the chaplaincy of Fortress Monroe hospitals. After the war he accepted a call from the Presbyterian church at Highland Falls, and here gathered materials for his *Nature's Serial Story*. In 1874 he removed to Cornwall-on-Hudson, and in this beautiful retreat, surrounded by fruits and flowers, most of his books were written. On the burning of Chicago, in 1871, he felt irresistibly drawn to visit the scene. Here, when sitting on the steps of Robert Collyer's church, his first story, *Barriers Burned Away*, began to take form in his mind. It had sale of 69,000 copies, and, encouraged by the unforeseen success, he now devoted himself to literature, and soon realized an income larger than any other American writer. His 16 works, mostly novels, have had a sale of 750,000 copies. Among his best-known works of fiction are: *Opening of a Chestnut Burr*; *Near to Nature's Heart*; *A Knight of the XIX Century*; *He Fell in Love with his Wife*. His horticultural productions are: *Culture of Small Fruits*; *Success with Small Fruits*; *Play and Profit of a Garden*. On July 19, 1888, he suddenly succumbed to neuralgia of the heart. Roe was pre-eminently a writer for the people, with whom he was in fullest sympathy, and whom it was his aim to elevate as well as to please. His style is simple, direct, and, though somewhat sensational, ever permeated by a strong feeling of morality. It has been said of him that he never wrote a line he could not preach.

ROEBLING, WASHINGTON AUGUSTUS, engineer, was born at Saxenburg, Pa., May 26, 1837. He is the son of the famous bridge-builder, John Augustus Roebling (1806—1869), for whom see *ENCYCLOPÆDIA BRITANNICA*. After graduating at Fessselaer Polytechnic Institute in 1857 he began work under his father at Pittsburg. In 1861 he enlisted in a New York artillery company and served in the Army of the Potomac. He was appointed on the staff of Gen. McDowell, and later on that of Gen. Pope, and engaged as military engineer, bridge-builder, and aeronaut. After rising to the rank of major in April, 1864, and winning higher brevets, he resigned in January, 1865, and resumed work with his father, who was then engaged on the railroad suspension bridge at Cincinnati. Of these Washington soon took nearly entire charge till its completion in 1867. In the next year he studied in Europe the system of pneumatic caissons for foundations, and on the death of his father, July 22, 1869, he was called to finish his plans for the construction of the famous Brooklyn bridge. After a severe attack of caisson fever in 1872, he endeavored, while still so weak as to be unable to leave his room, to continue his superintendence of the bridge, but was compelled in 1873 to recruit his health by a visit to Europe. On his return he resumed work and finally completed the bridge in 1883. He has since been engaged chiefly in conducting at Trenton, N. J., the wire manufactory established by his father.

ROGERS, CHARLES, Scotch author and antiquary, was born at Dunino, Fife, Scotland, April 18, 1825. He was educated at St. Andrews and was ordained in the established church in 1846. He was chaplain of Stirling Castle from 1855 until 1863, and succeeded in arousing such national interest in behalf of that early residence of Scotch kings that he was able to effect its complete restoration and to erect monuments to Wallace and the Bruce. He also induced Dean Ramsay to take the lead in the movement for the erection of a statue of Dr. Thomas Chalmers in Edinburgh. The organization of the Royal Historical Society in 1865 in London was due to his efforts, and he was its secretary until 1881. Much of his time has been devoted to genealogical investigations. His principal works are: *Scotland Social and Domestic*; *Monuments and Inscriptions in Scotland*; *A Century of Scottish Life*; *Traits and Stories of Scottish People*. He also com-

piled *Lyra Britannica*, a collection of hymns, and *The Modern Scottish Minstrel*, edited various fragments of early Scotch poetry, and wrote some popular religious books. He claims to have suggested to the British government, in 1868, the use of postal cards.

ROGERS, HENRY DARWIN (1808-1866), geologist, was born at Philadelphia Aug. 1, 1808, being the son of Dr. P. K. Rogers, who taught chemistry and physics successively in Philadelphia, Baltimore, and at William and Mary College. Henry was made professor of natural philosophy at Dickinson College, Carlisle, in 1831. He conducted a geological survey of New Jersey, and published a *Report and Map* (1835-40). Meantime he had been placed in charge of a similar survey of Pennsylvania, on which he was engaged from 1836 till 1855. Besides five annual *Reports* he prepared *The Geology of Pennsylvania* (3 vols., 1858, with 5 maps), which was published at the expense of the State. Having gone to Edinburgh to supervise the execution of the maps, he was called to the chair of natural science in the University of Glasgow, which position he held till his death, May 26, 1866. He edited the *Geological Atlas of the United States* (Edinburgh, 1861).

His brother, WILLIAM BARTON ROGERS (1805-1882), began to lecture on chemistry in 1827 and succeeded his father in his professorship in William and Mary College in 1829. He was made professor in the University of Virginia in 1835, and commenced a geological survey of that State which was discontinued in 1842. In 1853 he removed to Boston, where in 1864 he organized the Massachusetts Institute of Technology, and held the presidency of this institution ten years. He had in 1840 been active in forming the Association of American Geologists, from which eventually grew the American Association for the Advancement of Science. The latter body chose him to be its president in 1876, when distinguished scientists of Europe were expected to attend its sessions. He died at Boston, May 30, 1882. He contributed many important papers to the scientific bodies of which he was a member.

Two other brothers, JAMES BLYTHE ROGERS (1803-1852) and ROBERT EMPIE ROGERS (1814-1884), were eminent professors of chemistry, and were successively connected with the University of Pennsylvania.

ROGERS, JOHN (1505-1555), an English martyr, was born at Deritend, near Birmingham, in 1505. Having graduated at Pembroke Hall, Cambridge, in 1525, he became rector of a church in London. In 1534 he was made chaplain of the Merchant Adventurers at Antwerp. He had already embraced the doctrines of the Reformation and was intimate with Tyndale and Coverdale. He edited from Tyndale's manuscripts a revised English version of the Bible, which was issued in 1537 under the name of Thomas Matthew. Returning to England in 1545 he was again rector in London, and Bishop Ridley made him prebendary of St. Paul's in 1551. His sermon at St. Paul's Cross after the accession of Queen Mary caused him to be summoned before the Privy Council. He was then imprisoned in his own house and afterwards at Newgate. He was tried for heresy, condemned to death, and burnt at Smithfield, Feb. 4, 1555. The rude wood-cuts of Fox's *Book of Martyrs* and the *New England Primer* have perpetuated the scene. J. L. Chester (*q. v.*) prepared a careful biography of Rogers (1861), which disproves the claim of certain New England families to be descended from the martyr.

ROGERS, JOHN, statuary, was born at Salem, Mass., Oct. 30, 1829. After some youthful experience of mercantile life, he studied civil engineering and afterwards became a practical machinist, and had charge of a railroad repair shop at Hannibal, Mo. But his desire to study art led him to Paris in 1857, and afterwards at Chicago he modelled clay groups called *The Checker-Players* and *The Slave-Auction*, which attracted considerable attention. His famous series of war groups, beginning in 1861 with *The Picket-Guard*, made his name a household word. This series included

Taking the Oath, *The Home Guard*, *One More Shot*, *Union Refugees*, *The Camp Fire*, *The Returned Volunteer*. Before the close of the war he had greatly improved the mechanical execution of his works. Then other phases of American life began to furnish subjects. Among the most popular have been *Uncle Ned's School*, *The Country Post-Office*, *The Town Pump*, *The Visit to the Parson*, *The Doctor's Visit*, *School Examination*, *The Favorite Scholar*, and *Rip Van Winkle*. His groups are graceful and lifelike, sometimes pathetic and often humorous. They number altogether 64. Rogers has also executed statuary for lawns and gardens.

ROGERS, RANDOLPH, sculptor, born in Waterloo, near Auburn, N. Y., July 6, 1825, did not begin the study of art until twenty-three years of age. He studied under Lorenzo Bartolini, in Rome, from 1848 to 1850, then for five years he had a studio in New York, after which he returned to Italy in 1855. His works include the ideal busts, *Ruth* (1851) and *Isaac* (1865); *Nydia* (1856); *Boy Skating* (1857); *Angel of the Resurrection* (1861-2), which is on the monument to Col. Samuel Colt, in Hartford, Conn.; *Lost Pleiad* (1875); *Genius of Connecticut* (1877), on the State capitol at Hartford; memorial monuments for Cincinnati (1863-64), Providence (1871), Detroit (1872), and Worcester, Mass. (1874), an equestrian group of *Indians* (1881), and portrait statues of *John Adams* (1857), placed in Mt. Auburn cemetery, *Abraham Lincoln* (1871), in Fairmount Park, Philadelphia, and *William H. Seward* (1876), at Broadway and Fifth avenue, New York. The bas-reliefs on the bronze doors of the capitol at Washington, one of his best known works, representing scenes from the life of Columbus, were designed in 1858. He also completed the Washington Monument at Richmond, which Thomas Crawford had left unfinished. Crawford had made no designs for the statues of *Mason*, *Marshall*, and *Nelson*, and these, as well as some allegorical figures, were added by Rogers.

(F. L. W.)

ROHLFS, FRIEDRICH GERHARD, a German explorer, was born at Vegesack, April 14, 1831. After studying medicine he went to Algeria in 1855 as a surgeon in the French army. In 1860 he passed to Morocco, and in the disguise of a Mohammedan was the first European to enter the Oasis Tafilet. On his return journey he was severely wounded. In 1863 he crossed the Atlas Mountains, visited the Oasis Tuat, and returned by the way of Rhadames and Tripoli. In a third expedition in 1866 he reached Lake Tchad and crossed through Soudan to the Niger and the Guinea coast. In 1867 he joined the English expedition into Abyssinia, and in the following year sent *Nachtigal* (*q. v.*) with the king of Prussia's presents to the sultan of Borneo, while he himself explored Cyrenaica and went thence to Egypt. In 1873, under the patronage of the Khedive, he led an expedition through the Libyan desert. A visit to the United States in 1875 gave him an agreeable relief from these African journeys, but in 1878 he resumed his explorations of the Sahara and in 1880 delivered to King John of Abyssinia a letter from the German emperor. In 1884 he was made German consul-general at Zanzibar, but did not long retain the post. Since 1870 Rohlf's residence has been at Weimar, when he has not been engaged on foreign travel. His publications comprise narratives of his various expeditions and essays on the exploration of Africa and development of its resources. The most important are *Quer durch Afrika* (2 vols., 1875); *Entdeckung und Erforschung Afrika's* (1876-81); *Meine Mission nach Abessinien* (1883).

ROLLING-MILLS. For the general history of the manufacture of iron in the United States see IRON, of which the present article is a continuation.

The approved American practice in rolling iron is to use "three high" trains so that the hot iron passes through between the lower and the middle rolls in one

direction, and returns in an opposite direction between the middle and the top roll.

While a majority of existing rolling-mill trains are driven by steam-engines through gearing, new plants are generally directly connected; that is, the engine giving the motive-power has its shaft coupled to the driving-shaft of a roll train, which revolves at the same speed as the engine, and in some cases the engine drives a muck train direct, and is geared to run a merchant train at higher speed, or *vice versa*. In large plants a reversing engine is employed which changes its motion with each pass through the rolls. Some of the older rolling-mills receive all or a part of their power from water-wheels.

Prominent specialties of manufactured iron form the bulk of business at a number of rolling-mills. Among these are plate, sheet, skelp, bar, nail-plate, wire beams and angles, etc., and the practice of making one or two specialties is becoming more common continually. Smooth or grooved rolls of various design or sizes are required for each purpose, and many mills require a large stock of extra rolls to fill the orders of different sizes and shapes. For certain purposes chilled rolls (made of iron cast in chills so as to give a hard surface) are employed. These are principally used for cold rolling or finishing, and are often highly polished.

Nail-plate is rolled from 12 to 20 inches in width, and of thickness required for different sizes of nails, so that the plate can be sheared transversely into bars which are fed into machines which cut nails, preserving the grain of the iron.

Plate-iron for boilers or ships is made in smooth three-high trains of large diameter, and as the weight of some of the plates is great the pile is of corresponding size. The best brands of boiler plate-iron are known as "C. II. No. 1," and "flange" iron—C. II. being an abbreviation for charcoal hammered, and indicating that the iron was made with charcoal in sinking fires, hammered into blooms, and rolled out into bars which were piled for plate-iron. The U. S. secretary of the treasury publishes in the rules governing the construction of boilers for steam-vessels provisions that the tensile strength shall be stamped on plate, and that the ductility shall be as follows: "Iron of 45,000 pounds per square inch tensile strength shall show a reduction of area of 15 per cent., and each 1000 lbs. tensile strength shall show 1 per cent. additional contraction of area up to and including 55,000 lbs. tensile strength. Iron of 55,000 lbs. tensile strength and upwards showing 25 per cent. reduction of area shall be deemed to have the lawful ductility."

Sheet-iron has been rolled to such small gauge as to be thinner than paper; this was merely experimental and required a superior quality of iron. Most of the sheet-iron is made from metal above the ordinary character. There is no defining line between sheet and plate-iron, the terms being affected as much by the purpose for which the product is used as by its thickness; but iron under 3-16th inch is generally considered as sheet and above that thickness as plate-iron.

Skelp-iron is a term applied to long, narrow sheets of iron rolled for the purpose of making wrought-iron tubing or flues, of which large quantities are demanded for plumbing, gas-fitting, water or gas supply, oil or gas wells, etc.

The manufacture of beams, channels, angles, and special shapes is rapidly extending, and demands a plant of large proportions and powerful machinery. Fire-proof construction, bridge and roof-building, ship-building, and modern architecture constantly call for new shapes and sizes. Beams up to 20 inches in height have been rolled. The development of this specialty is the growth of but a few years, but it promises to continue to increase both in quantity and variety of product.

For the statistics of the production of Rolled Iron in the United States see the end of article IRON.

Wire Rods.—The general features of puddling, heating, and regenerative furnaces, squeezers, hammers, roll-trains, etc., are given in the *ENCYCLOPEDIA BRITANNICA*. There are numerous improvements peculiar to American practice which apply to various specialties, but the advance has been more marked in the rolling of rails, particularly in connection with the Bessemer steel-works. In another specialty American practice has been remarkably progressive, viz., the rolling of wire. The requirements of this country are not less than 350,000 tons of wire rods per annum. Since on an average 125,000 to 150,000 tons are imported, there is a balance of at least 200,000 to 225,000 tons to be provided for by American works. These possess about 30 trains of roll, some of which roll small iron and merchant shapes during a part of the time. Steel wire rods are made a specialty by about a dozen firms.

The iron wire rod trains and modern steel rod mills do not work under the same conditions. For both rapid rolling is desirable, but for different reasons. With the first it is aimed at on account of its influence upon the character of the product; with the second, for the effect it has upon the cost. In order to reduce the number of passages through the wire draw-plate, rods for wire-drawing must be rolled to small dimensions, while avoiding anything that injures the quality of the iron. Speed in rolling tends to completely utilize the welding and to allow of making the small sizes aimed at before the wire grows too cool. If this temperature should be reached before the last pass, the transformation of the previous oval into round cannot be effected without affecting the molecular structure of the metal and robbing it of certain properties. The iron will be hardened, and in cooling will not be covered by the blue oxide but by reddish oxides. In order to manufacture No. 7 and No. 8 B. W. gauge, it is therefore necessary to increase the speed of rolling and to be content to roll pieces of moderate length, according to the softness of the metal treated.

It is a different matter with steel wire rods, which are rarely smaller than No. 5 B. W. gauge. With them the question of maintaining quality is not the ruling one. Steel is more easily rolled than iron, and in this case high speed is aimed at chiefly to reduce cost of labor and general expenses.

The oldest wire rod mill, the English train, consists of five stands of rolls in a line, viz., an 8½- to 10-inch three-high roughing set and four sets of 7- to 8-inch continuous rolls. In this system the speed of the rolls is limited by the skill of the workman. Its defects have led to its being generally replaced by what the Americans call the "Belgian" system. In it the roughing train is separate, having a speed below 200 revolutions, being a set of three 12- or 13-inch rolls, with the pinions placed at the outer end, in order to interfere less with the finishing train. The latter, placed parallel to it and 40 to 50 feet from it, consists of a stand of pinions and five to seven two-high sets, which may be driven at greater speed.

In some mills a further step has been taken. Instead of increasing regularly the size of all the finishing rolls, those of the two last sets have been increased half an inch, by which the corresponding passes, leaving injurious loops of wire between the last two, have been diminished.

An essentially American train is arranged to roll 4-inch blooms about 4 feet long, which are directly converted into rolls of wire several hundred feet in length. It suppresses one reheating, the loss, the cost and the waste of oxidation which that implies. This idea necessitates certain special arrangements. The passage from one set of rolls to the next must be prompt. Two to three blooms pass per minute, and 90 to 100 seconds suffice for the complete reduction of each one of them.

A train resembling the above, running since 1884, used 4-inch steel blooms weighing from 125 to 130 lbs. In one week, making 11 single turns, the mill rolled

420 gross tons of No. 6 rods direct from a 4-inch bloom. In one day of 10½ hours a record of 111,220 lbs. of No 6. has been made. A special feature is the use of natural gas at the boilers and two bloom reheating furnaces. The entire force for the operation of the mill was 40 men and boys.

The general arrangement and working of the last-mentioned plant are as follows: The boilers occupy one corner of the building, the heating furnaces and shears the front, the ingot-reheating furnaces one side, and the reels the other side. The blooming, billet, intermediate and continuous trains are located centrally, the axes of the three trains being parallel. After the bloom is reduced to the section and length desired it is heated in the furnaces before undergoing further work. It first goes through the billet train. When rolling steel the last set of this train, in which the billet is generally given only one pass, the rolls may be flat; when rolling iron, however, they must be grooved. The bloom is thus reduced to a 1 by ½-inch rectangular or oval section. It then goes through the intermediate train, where it is given a round, oval, or square section equivalent to a section of ½ by ¾-inch. It is then finished in the continuous train. The single set of rolls which constitutes the intermediary is placed behind the delivery pair of the billet train and in front of the first set of the continuous train, and in the same line of feed. The billet is carried from the billet train and fed to the intermediate train by a guide, and from this train to the continuous train by another guide tube. This last train consists of two parts and is composed of eight sets of rolls through which the billet passes in succession, conducted from one pair to the other by guides. In leaving the last pair of rolls the rod goes through a guide which conducts it towards the reels on which it is wound. One man handles the reels. He seizes the end of the rod, attaches it to one of the two reels, and while one is winding the other is emptied and got ready to receive the following rod. In this continuous rod-mill the wire is passing in opposite directions through different rolls simultaneously, and while the finished end is being wound on a reel the balance of the now reduced billet is still passing through several pairs of rolls.

The following represents the geographical distribution and general equipment of the rolling-mills of the United States not connected with steel works:

States.	Rolling mills.	Puddling furnaces.	Reheating furnaces.	Trains of rolls.	Hammers.
Maine.....	2	20	11	6	
New Hampshire.....	1	2	20	3	11
Vermont.....	1	15	8	2	
Massachusetts.....	29	80	155	87	37
Rhode Island.....	1	6	8	
Connecticut.....	9	12	37	24	3
New York.....	26	200	135	78	20
New Jersey.....	16	159	94	55	27
Pennsylvania.....	169	2,478	1,026	650	159
Delaware.....	10	38	20	26	6
Maryland.....	9	98	59	32	8
District of Columbia.....	1	2	1	3
Virginia.....	5	63	30	16	1
Alabama.....	4	45	11	17	3
Texas.....	1	8	2	
West Virginia.....	8	210	37	27	
Kentucky.....	7	105	43	36	8
Tennessee.....	4	45	22	12	1
Ohio.....	54	902	204	115	25
Indiana.....	8	116	61	25	3
Illinois.....	13	124	68	37	1
Missouri.....	7	36	39	18	22
Iowa.....	1	2	1	
Michigan.....	2	31	23	2	4
Wisconsin.....	1	30	26	7	1
Minnesota.....	1	2	1	
Kansas.....	1	11	3	2
Nebraska.....	1	2	8	
Colorado.....	3	12	9	7	
Wyoming Territory.....	1	10	2	1
California.....	4	4	34	11	18
Total.....	401	4,907	2,199	1,314	341

ROMAN CATHOLIC CHURCH. This article treats only of the history of this church in the United States. This church is coeval with the earliest attempted settlements by the Spaniards at the South, by the French in Maine, along the Lakes, and down the Mississippi Valley, and by English Catholics in Maryland after ineffectual projects in Maine. Ponce de Leon, after discovering Florida in 1513, attempted a settlement in 1521, accompanied by priests; and in 1526 Ayllon began a settlement on James River, Va., two Dominican priests, Fathers Anthony de Montesinos and Anthony de Cervantes, beginning the regular ministrations of religion. The expeditions of Narvaez and Soto were attended by priests, but no settlement was made. A Franciscan Father, Mark of Nice, on information given by survivors of Narvaez's force, penetrated to the Zuñis, of New Mexico, and missionaries with Coronado's expedition, 1540-42, penetrated to the country near the Missouri and Mississinpi, where Father Padilla and a companion were killed by the natives. Father Luis Carcer met the same fate in Florida in 1549, while attempting to found a mission, unprotected by soldiery or colonists. An expedition under Luna near Pensacola, 1558-61, failed, the Catholic service being regularly offered there by priests who accompanied them. The first permanent settlement at St. Augustine, Sept. 8, 1565, was begun with the celebration of mass by Rev. Martin Francisco de Mendoza Grajales, the first parish priest, and the service of the church has been continued in Florida with brief interruption (1763) to the present time. The parish registers of St. Augustine are extant from Jan. 1, 1594. From St. Augustine Indian missions were extended north and south, and an attempt was made even on the Rappahamock, where several Jesuit missionaries were put to death (1571), as Franciscans were on the Georgia coast (1597). The Catholic clergy in Florida were subject to the Bishop of Santiago de Cuba. In the West the Franciscan Rodriguez and his companions penetrated to New Mexico to found a mission, but perished (1581). This led to the occupation of the country by Don Juan de Oñate in 1595. He began a settlement at San Juan de los Caballeros, where a church was erected (August-September) and the regular services of the Catholic worship begun; missions were established among the Pueblo Indians, and as converts were made churches were established in most of their towns. These continued till 1680, when the Indians rose against the Spaniards, massacred most of the missionaries, and drove all whites from New Mexico. When the territory was reoccupied by Vargas in 1692 the clergy of the Catholic Church resumed their labors among whites and Indians, and continue them to this day. The churches were under the charge of the Bishop of Guadalaxara, and subsequently under the Bishop of Durango. In 1696 the Jesuit Father Kühn founded the mission of San Xavier del Bac and others in the present Arizona, and during the eighteenth century priests of that order pushed their California missions northward.

At the North, after laboring in Nova Scotia, the Jesuit Father Biard attempted to found a mission settlement on Mount Desert Island, which was broken up by Argall (1613). As the Jesuit missions in Canada extended, Dreuillette founded a mission among the Abnakis on the Kennebec (1646); Jogues (*q. v.*) among the Mohawks (1646); Le Moyne among the Onondagas (1654); Menard among the Chippewas (1660). The missions thus founded were followed up with wonderful zeal and courage. The Indians from the Passamaquoddy and Penobscot to the Kennebec became and remain Catholic; numbers of converts were made among the Five Iroquois nations, whose descendants are found now at Caughnawaga, the Lake of the Two Mountains, and St. Regis. The remnant of the Tionontate Hurona were gathered on Lake Superior, and finally at Sandusky, and missions were established among the Ot-

tawas, Chippewas, Sacs, Foxes, Menominees, Winnebagoes. Father Marquette sought to extend Christianity to the Illinois, Miami, and other tribes in the valley of the Mississippi, and accompanied Joliet on his exploration of the Mississippi to the Arkansas. He died after founding a mission in Illinois. These Jesuit missions under Drenillettes, Jogues, Lamberville, Menard, Allouez, Gravier form a remarkable chapter in American history. The Franciscan Recollects followed with missions in Illinois, and churches at Niagara and Detroit, Father Hennepin reaching the country of the Sioux and naming St. Anthony's Falls. Priests of the Foreign Missions from Quebec then established parishes among the colonists at Cahokia and Mobile, and attempted Indian missions among the Natchez and other tribes. When Louisiana was settled, the care of the settlements was confided to the Capuchin Fathers and the Indian missions to the Jesuits, several of whom perished at the hands of the Natchez and their allies. All these parishes and missions were subject to the Vicar Apostolic of Canada (1658), who became Bishop of Quebec in 1674. The Indian missions were annihilated by the hostility of the French government to the Society of Jesus and the loss of the country in 1763.

The colonies of Virginia, Plymouth, and Massachusetts Bay excluded Catholics, and they were not tolerated by the Dutch in New Netherland. Projects of Catholic settlement were attempted by Sir Thomas Gerard under Sir Humphrey Gilbert and by Lord Arundell of Wardour under Capt. Weymouth, but failed. Sir George Calvert, Lord Baltimore, after being repulsed from Virginia as a Catholic, obtained a patent for lands lying south of that colony in his own name and that of Sir Thomas Arundell, and when that patent was revoked obtained another for Maryland, lying north. Here his son Cecil founded the colony of Maryland, most of the landed gentry and many of the settlers being Catholic, and ministers of no other religion appearing for years. The services of the Catholic Church began on St. Clement's Island, on the Potomac, March 25, 1633, under Revs. Andrew White and John Altham. This was the nucleus from which the organization of the church in the British provinces in colonial days grew. The Catholic Church in Maryland enjoyed a period of comparative freedom till 1645, when Clayborne overthrew the power of Lord Baltimore, carried off Father White and others to England, and compelled the rest of the Catholic priests to seek refuge in Virginia, where they lay concealed, suffering greatly, two dying soon after. When Lord Baltimore's authority was restored, other priests came over, and in 1649, under the impulse of the lord proprietor, a general act of religious toleration was passed. But in 1652 Clayborne and Bennett in the name of the Commonwealth overthrew the proprietary government, excluded Catholics from the Assembly, which then passed an act disfranchising them completely. The priests again took refuge in Virginia, from which they visited their flocks by stealth. On the Restoration the Jesuit Fathers resumed their work in Maryland, and in 1672 the English Franciscans founded a mission in that province which lasted about half a century. When James, Duke of York, took possession of New Netherland and made it the English colony of New York, religious liberty was granted and Catholic officers and settlers arrived. Jesuit Fathers came over in 1683, and the services of the Catholic Church commenced. A Latin school was established here as one had been in Maryland, the New York Assembly in its Bill of Rights establishing religious freedom. Penn, in settling Pennsylvania, adopted the same liberal policy, and Catholics began to settle in that province. The Revolution of 1688 was followed by a reaction. Lord Baltimore was deprived of the administration of Maryland; Catholics were again disfranchised there and in most of the colonies; in Maryland they were compelled to support Protestant clergy and

contribute to the erection of Protestant churches, subjected to double taxes; and in Virginia their testimony could not be received in any case, civil or criminal. This state of things continued to the American Revolution. No churches could be erected, and Catholics had only private chapels connected with houses and under the same roof. In Pennsylvania alone were there Catholic churches, at Philadelphia, Lancaster, Conewago, Goshenhoppen.

The conquest of Canada by England in 1763 crippled the church in that province, and the churches at Detroit, Vincennes, and other points in the West suffered; the action of the French government against the Society of Jesus cut off the supply of priests for the Jesuit missions among the Indians; and the complete suppression of the order by Pope Clement XIV. in 1773 left the Catholics in Maryland with no source for a supply of priests. They had been subject to the Vicar Apostolic of the London District in England, who had no means of sending clergymen. Bishop Challoner endeavored to have a bishop appointed as Vicar Apostolic for Maryland and Pennsylvania, but failing in this, sought to have the Catholics there after 1763 placed under the control of the Bishop of Quebec. England obtained Florida also by cession from Spain, but the old population withdrew. Minorcans were introduced at New Smyrna by Dr. Turnhill and they were accompanied by priests. This colony finally rebelled against their cruel treatment and removed to Saint Augustine, accompanied by the priests, and their descendants at this day form part of the population. Mobile also passed into the hands of England, but the French settlers and their priest remained. This was the position of the Catholic body in British territory when, in 1774, the Quebec Act recognized the Catholic Church in the country north-west of the Ohio and reannexed that district to Canada, a step which precipitated the American Revolution and gave that movement in its early stages a strong anti-Catholic character.

When the struggle between the Thirteen Colonies and Great Britain actually began, the desire of conciliating and winning the Canadians, who actually raised two regiments, as well as the hope of gaining sympathy, if not direct aid from France and Spain, dictated a more kindly policy. Washington checked in his camp the celebration of Pope-Day on Nov. 5, and Congress appointed a Catholic chaplain in the army. Envoys from France and Spain, the service of the Catholic Church by French army and navy chaplains, attended by State and Federal officials, soon made the once hated church less odious, while the adherence of Catholics to the national cause secured a degree of favor. At the close of the Revolutionary war there were bodies of Catholics scattered through the country, chiefly in the large ports. The number in all probability exceeded 50000: the clergy in Maryland, who during the war had been disowned by the Vicar Apostolic of the London District, applied to the Pope for a national organization and a local superior. A French intrigue sought to subject American Catholics to a bishop nominated by the French king, but Pius VI. in 1784 appointed the patriotic Rev. John Carroll Prefect Apostolic in the United States, and in 1789 erected the see of Baltimore, creating as first bishop the Rev. Mr. Carroll, who had been nominated by the almost unanimous voice of the clergy. At this time there were Catholics not only in Maryland, Pennsylvania, and New Jersey, with a few in Virginia, but also in Boston, New York, Charleston, and Savannah, Catholic Indians in Maine and New York, and a considerable body of French origin north-west of the Ohio and on the banks of the Mississippi. Bishop Carroll, whose diocese was coterminous with the limits of the republic, soon asked to have it divided, as the number of Catholics was gradually increasing by emigration from Europe. A coadjutor was at first assigned to him, but in 1808 new sees were erected at New York,

Boston, Philadelphia, and Bardstown, Ky., and Dr. Carroll was made Archbishop of Baltimore, retaining jurisdiction over the Catholics in Maryland and the States to the southward on the Atlantic and westward to the Mississippi. Some parts held for a time by England and Spain had eventually come under national control. The French Revolution sent to the United States many priests of great learning, zeal, and piety. The Sulpitians founded a theological seminary at Baltimore, the members of the old Society of Jesus founded Georgetown College, and established a high-school at New York, reorganized in connection with the body in Russia, and were finally fully restored by the Pope in 1815. English Dominicans driven from Belgium founded a province of the order in Kentucky; a community of Carmelite nuns from Europe was established at Port Tobacco, Md.; one of the Visitation order was organized by Bishop Leonard Neale, the coadjutor and successor of Carroll; the Sisters of Charity were founded by Mrs. Eliza A. Seton, a New York lady who entered the Catholic Church, and similar bodies were founded in Kentucky by Bishop David and Rev. Charles Nerineck. A combined seminary and college was established at Emmitsburg, Md., and schools in various parts. The printing of Catholic books almost impossible in colonial days began: the Bible was printed in 1790 and 1805, as well as devotional, instructive, controversial, and apologetic works.

The cession of the vast province of Louisiana to the United States in 1803 and of Florida in 1820 added a considerable Catholic element to the population. These provinces after being made subject ecclesiastically to the Bishop of St. Christopher of Havana in 1787 had been erected into a diocese in 1793, but at the time of the cession were without a bishop, and in a state of disorder, with few clergymen and neglected parishes. Bishop Carroll was appointed Administrator, but could do little to restore discipline or revive religion. He finally under authority from the Pope appointed Rev. William Du Bourg Administrator, who, in 1815, was consecrated Bishop of Louisiana and the Floridas.

The Catholic population in the United States up to this time was mainly of native birth, with some accessions by immigration and the children of those who reached the country after 1783, but the close of the wars of the French Revolution was followed by a great tide of emigrants from Great Britain and in time from other parts of Europe, a large proportion of which was Catholic. These new-comers followed the lines of the great public works, and improved means of communication and helped to build up the North and West, where the Catholic body rapidly increased in numbers and influence, the slave labor at the South generally excluding them from that section. In the movement of the older population westward Catholics were also largely represented. Sees were established at Richmond and Charleston in 1820; at Cincinnati in 1821. A few years afterwards the great diocese of Louisiana was divided and sees erected at New Orleans and St. Louis, while Alabama and Florida were assigned to a Vicar Apostolic, who soon became Bishop of Mobile.

The necessity of concerted action as to discipline had been felt, and in 1829 the first Provincial Council of Baltimore was held, Archbishop Whitfield presiding, nearly all his suffragans, and Bishop Rosati of St. Louis, though not of the province, attending. Great difficulties had arisen in Charleston, Norfolk, and Philadelphia, from the action of trustees of churches, who claimed the right of nominating and instituting priests, and refused to admit or recognize priests appointed by the bishop of the diocese. The trouble in Philadelphia lasted for years and the diocese was at this time actually managed by an administrator. The council declared expressly that no right of patronage vested in the trustees and maintained the right of each bishop to appoint and remove priests in

his diocese, and directed the interdiction of any church where the trustees refused to receive the priest appointed or refused him the usual salary. By this time the Catholic body numbered about 500,000, under an archbishop, 9 bishops, about 200 priests, and with as many churches, several theological seminaries, 8 colleges, and 20 academies for young ladies. The strong prejudice against the Catholic Church about this time was increased by publications issued in England in opposition to the emancipation of the body in the British isles. Similar publications appeared here, like that fiction ascribed to Maria Monk, and one of the results was the destruction by a mob of the Ursuline Convent at Charlestown, Mass., in 1834, resulting in the death of one of the nuns. (See RIOTS.)

In spite of this movement the growth of the Catholic Church increased. Bishops were established at Detroit in 1832, Vincennes, Ind., in 1834, Dubuque, Iowa, Nashville, Tenn., and Natchez, Miss., in 1837. Each new see became a centre where a bishop labored to build up churches and institutions. Aid was afforded to these struggling churches by the Association for the Propagation of the Faith, a society established in France to aid foreign missions, mainly through the influence of Bishop Du Bourg of Louisiana, and by the Leopold Verein, a similar organization at Vienna, emanating from the appeals of Bishop Résé, first Bishop of Detroit. Catholic papers, magazines, and books increased in number and circulation, and attempts were made to revive and extend the old Catholic missions among the Indians. Those in Maine had always been maintained; that in Northern New York was attended from Canada; work was renewed among the Ottawas, Chippewas, Pottawatamies, Kickapoos, and Kansas, by the Redemptorists, Jesuits, and secular priests like Baraga and De Seilles. Tribes on the Rocky Mountains hearing of the Catholic faith sent to St. Louis for priests, and Father Peter J. De Smet became the apostle of the Flatheads and other mountain tribes. In 1843 bishops were established at Little Rock, Ark., and Pittsburg, Pa., and the next year at Hartford, Chicago, and Milwaukee, and Oregon Territory was formed into a Vicariate Apostolic in 1843.

About this time a question arose which has often inflamed the public mind. The early schools of the country were all under church control, but others grew up, all aided by the State. In New York frauds brought church schools into disrepute, and the schools of the Public School Society at New York alone received aid. These were distinctly Protestant in management, teachers, books, and tone, and Catholic children were subjected to constant annoyance. The petition of the Catholics for the revival of the former aid to their schools raised the famous school question, never yet satisfactorily adjusted. Bishop Hughes, of New York, distinguished himself in a debate before the New York Common Council, and a system of State schools grew up and spread to many States, but the original difficulty remains. The discussion in 1842 roused great opposition, and a political party, "Native Americans," opposed to Roman Catholics, and to the influx of foreign mechanics, was formed. The attempt of the party to hold meetings in a part of Philadelphia largely populated by Irish Catholics led to furious riots in 1844, in which two Catholic churches, a convent, and many houses of Catholics were destroyed before the authorities could restore order. At this time (1844) the Catholic churches in the United States numbered 21 dioceses, 1 vicariate, 634 priests, 611 churches, with a population of 1,300,000.

The annexation of Texas in 1845 added an old Catholic district, and the subsequent war with Mexico added to the national domain New Mexico, California, and Arizona, with white and Indian Catholics. Texas had been from 1689 the scene of missions founded by a remarkable man, the Ven. Anthony Margil; New Mexico had been directed for two cen-

turles by Franciscan and other priests, and in California was a series of missions founded by Father Juniper Serra and other Franciscans; while Arizona had missions founded by F. Eusebius Kühn, S. J. Texas was made a prefecture apostolic in 1840, and a see erected at Galveston in 1847; a bishop had been appointed for California in 1840, and one was established at Monterey in 1850, and a vicar apostolic at Santa Fé, New Mexico, in the same year. In these parts the church had labored to revive religion in the Spanish and Indian elements, and to meet the wants of the new body of Catholics from the older States and Europe. In the older parts the growth of the Catholic Church continued, and to meet it Oregon City was made an archbishop's see in 1846, St. Louis in 1847, New Orleans in 1850, and San Francisco in 1853; and bishops' sees were erected in 1847 at Albany, Buffalo, Cleveland, and in 1850 at Nesqueally, St. Paul, Savannah, and Wheeling. The great province of Baltimore, which from 1808 included all east of the Mississippi, was divided in 1850 by the erection of archbishoprics at New York and Cincinnati; New York, Cincinnati, St. Louis, Oregon City, and San Francisco thus became centres, and each archbishop with his suffragan held provincial councils, and stimulated the erection of churches and institutions, the establishment of discipline, the care of the religious education of the young.

To secure uniformity on several points of ecclesiastical discipline a plenary council of all the archbishops and bishops of the United States was held at Baltimore in May, 1852, and has been followed by two others in 1866 and 1884. Sees were erected at Brooklyn, Burlington, Covington, Erie, Natchitoches, Newark in 1853; Portland in 1855; Fort Wayne and Sault Ste. Marie in 1857. Progress had been steady although a political party was formed about 1853, a priest tarred and feathered in Maine, and churches destroyed in some parts of the country. In 1861 when the civil war broke out the Catholic Church in the United States comprised 7 provinces, 45 bishops, 2317 priests, 2517 churches, 49 theological seminaries, 300 colleges and female academies, 660 parochial schools, 230 charitable institutions. The war checked immigration and crippled greatly the feeble churches and institutions in the Southern States. In 1888 the Catholic Church in the United States numbered 11 archbishops, one of them a cardinal, 68 bishops, 7596 priests, 6829 churches, 91 colleges, 588 academies, 2606 parochial schools, with 511,063 pupils, 472 charitable institutions, and with a population of nearly 10,000,000.

In promoting and conducting this remarkable progress of the church the eminent men have been Archbishops Carroll, Kenrick, and Spalding, of Baltimore, Cardinals McCloskey and Gibbons, Bishops England and Lynch, of Charleston; Hughes, of New York; Henni, of Milwaukee; Cheverus and Fenwick, of Boston; Flaget, of Louisville; Du Bourg, of New Orleans; Neumann, the holy bishop of Philadelphia; O'Connor, of Pittsburgh; Ireland, of St. Paul; Archabbot Wimmer, who introduced the Benedictines into the country; Very Rev. Edward Sorin, founder of Notre Dame, Ind.; Prince Demetrius Galitzin, Rev. Charles Nerinckx, Kentucky; Rev. Peter J. De Smet, S. J., and Bishop Baraga, in Indian Missions; Mgr. Corcoran and Rev. I. T. Hecker, Father Müller, C. S. S. R.; Rev. Charles I. White, Rev. F. X. Weninger, Rev. C. C. Pise; Dr. O. A. Brownson, eminent in philosophy; J. A. McMaster, editor. Among women Mrs. Seton, foundress of the Sisters of Charity; Teresa Lalor, of the Visitation Nuns; Mine. Galitzin, of the Ladies of the Sacred Heart.

At the present time few countries have so many religious orders as the United States, where there are Benedictines, Cistercians, of La Trappe, Franciscans, Dominicans, Augustinians, Carmelites, Jesuits, Redemptorists, Passionists, Sulpitians, Sanguinarians, Oblates, Priests of the Holy Cross, of the Resurrec-

tion, of Mercy, Capuchins, Lazarists, Fathers of the Holy Ghost and of St. Viateur, Paulists, Servites; Nuns of the Benedictine, Carmelite, Franciscan, Dominican, Ursuline Orders, Sisters of Charity, Mercy, the Good Shepherd, the Holy Cross, St. Joseph, Christian Charity, Felician Sisters, Sisters of Providence and of Loretto, School Sisters of Notre Dame, Bon Secours Sisters, Sisters of St. Agnes, St. Anne, St. Clare, of the Holy Child, of the Holy Name of Jesus and Mary, of the Immaculate Heart, Incarnate Word, Presentation, Alexian Brothers, Brothers of the Christian Schools, Brothers of Mary, Franciscan Brothers, Brothers of the Holy Cross, Xaverian Brothers, Brothers of Charity, Brothers of Good Works. The communities of Sisters and Brothers are engaged in teaching, or the direction of hospitals, asylums, and other charities.

The latest step has been the foundation at Washington, D. C. of a great Catholic University, of which Rt. Rev. John J. Keane, D. D., Bishop of Richmond, has been appointed rector. The leading periodicals of the church are the *American Catholic Quarterly*, the *Catholic World* (monthly), *Ave Maria*, *Messenger of the Sacred Heart*, the *Freeman's Journal*, *Catholic Universe*, *Warheits Freund*, *Propagateur Catholique*, *Revista Catolica*, *Catholic Standard*, *Catholic Review*. (J. G. S.)

ROMANS, EPISTLE TO THE. The article in the See Vol. XX. ENCYCLOPÆDIA BRITANNICA on the p. 727 (p. 746 Am. Rep.). Epistle to the Romans presents few points open to censure, though opinions necessarily differ in regard to some of the positions taken. The present article proposes to treat of the two earlier groups of Pauline epistles, indicating some of the questions which arise in discussing them, whether from the historical or exegetical point of view.

The general view taken of the epistles, the order of writing, purpose, etc., may be found in the article PAUL.

I. *The earlier group of Epistles.*—The first written were 1 and 2 Thessalonians. These stand by themselves in some respects, while the four other epistles, written during the third missionary journey, are closely related to each other. The genuineness of 1 Thessalonians is accepted in the BRITANNICA, but doubts are cast upon 2 Thessalonians. These doubts arise entirely from exceptions taken to the contents of the epistles, especially the admonition against the expectation of the speedy coming of the day of our Lord (2 Thess. ii. 1-3, etc.). But the second epistle seems a very natural sequel to the first, and the external testimony supporting its genuineness is conclusive to those who duly weigh such evidence.

The four other epistles, written within one year (A. D. 57-58), are Galatians, 1 and 2 Corinthians, Romans. They are frequently spoken of as the "undoubted" Pauline epistles, since the genuineness of all is undisputed.

The Epistle to the Galatians.—There is a difference of opinion as to the chronological position of Galatians; some place it before 1 Corinthians, regarding Ephesus as the place of writing; others think it was written at Corinth, shortly before Romans (Conybeare, Lightfoot, and others). In favor of Ephesus we may urge the nearness to Galatia, the strong emotion showing that the news of the defection had come to the apostle quite recently. In favor of Corinth it is urged that the epistle resembles 2 Corinthians in tone and Romans in thought, and that the later date accords better with the history of Paul's conflicts. But the difference between the *tone* of Galatians and that of Romans, in spite of the similarity of thought, seems to indicate a longer interval between the two. We therefore prefer the earlier date, at Ephesus, which is usually accepted by German and American scholars.

The contents of the Epistle to the Galatians are readily analysed. Chaps. i., ii., the apostle's defence

of his apostleship; chaps. iii., iv., a defence of his preaching (justification by faith, life by the Spirit, not according to the flesh); chaps. v., vi., practical exhortation, to stand fast in the freedom for which Christ freed us.

The Epistles to the Corinthians.—In these we also discover the apostle attacking error and defending himself. But the error is by no means so fundamental. There is no evidence of Judaizing opposition. The evils in the Corinthian Church were mostly practical; party spirit prevailed, some sexual sins were tolerated, disorders were allowed in the public assemblies, and among the believers there were erroneous views respecting the resurrection. News of all this having come to Ephesus, the apostle writes thence his first letter, probably just before the riot spoken of in Acts xix. This letter deals first with the party divisions and Paul's mode of teaching; chaps. i.-iv. (It is not at all certain that these parties were fully developed divisions in the church, though some attempt to prove this.) In chaps. v.-vi. he alludes to the sin of unchastity, and to the habit of going before heathen magistrates. Then follow replies to questions that had been submitted to him about marriage, and meat that had been offered to idols; chaps. vii.-viii. A digression of a personal character then occurs; chaps. ix.-x. A direct censure of the disorders in church assemblies (chap. xi.) prepares the way for a discourse about spiritual gifts (chaps. xii.-xiv.), in the midst of which (chap. xiii.) is placed that remarkable eulogy on "love" as "a still more excellent way." The discussion about the resurrection (chap. xv.) is the only portion of the epistle that is distinctly doctrinal, and the latter part of it assumes a prophetic character. Injunctions respecting the collection for the saints at Jerusalem, a matter which the apostle was now pressing upon many of the churches, and personal notions and greetings make up the conclusion in chap. xvi.

After writing this epistle Paul left Ephesus, and passing through Troas (2 Cor. ii. 12) sailed to Macedonia (Acts xx. 1, 2). From some point in this province he wrote 2 Corinthians (2 Cor. viii. 1, ix. 2-4). It is possible that he wrote a brief letter previous to this, but nothing can be proven on this point. Some have thought that he made a brief visit to Corinth before writing 2 Corinthians, but this also lacks sufficient proof. Yet the occasion of the second letter preserved for us was evidently intelligence received from that city (chap. vii. 7-16), and this, too, not altogether reassuring. The larger part of the Corinthian Church seems to have accepted the admonitions given in the first letter, but Paul's opponents were embittered. The second epistle, in its abrupt changes of style, tone, and topic, shows the conflicting feelings of the apostle. He strives to win the malcontents, but evidently intends to exercise severe discipline upon them, should they remain refractory. Hence no one letter of Paul's reveals the man more fully; none of his writings show greater tact, power, and eloquence. The epistle is usually divided into three parts: chaps. i.-vii., a representative of the apostle's character and labors, but with constant appeals to the Corinthians themselves; chaps. viii., ix., further directions about the collection for the poor saints at Jerusalem; chaps. x.-xiii., a defence of his apostolic dignity, varied in tone and method, full of tenderness, yet very forcible in its appeals. This defence differs greatly from that in Galatians; the defection at Corinth was not doctrinal, but practical and personal. Hence he seeks far more to win by personal appeals. To the Galatians he speaks as by direct authority, making known the one revealed gospel; to the Corinthians he speaks as the pastor, clothed with authority, but desirous to win back those who have erred. It is, therefore, difficult to analyze this epistle, which for this very reason remains the most interesting picture at once of the apostle and of the early Gentile Christian Church.

The Epistle to the Romans.—1. *The purpose.* Com-

ing to Corinth the apostle remained there three months (Acts xx. 3), and during this time wrote the Epistle to the Romans; a fuller, more didactic setting forth of the same great truths of salvation which formed the theme of Galatians. But the polemic tone has largely disappeared. This would indicate that the state of things in Corinth was more satisfactory. At all events it enables us to determine more certainly the purpose of the epistle.

The article in the *BRITANNICA*, while clearly right in maintaining that the church at Rome was made up mainly of Gentile Christians, attempts to show that the purpose of the epistle was largely polemic, that is, directly in opposition to the false views of Jewish believers, if not of Judaizing teachers. No doubt there are abundant indications of such opposition. The conflict in Galatia was quite recent, and indeed there was a permanent antagonism between the universal scope of the gospel as maintained by Paul and the narrower view. But in this epistle the positive statement of the universal aim of the gospel is dominant; the polemical purpose is incidental. The apostle sets forth his own views, knowing that most of the Roman Christians are in sympathy with him. Being unable to visit them on account of the collection he is to carry to Jerusalem, he writes to them by Phœbe, xvi. 1, in order to strengthen and instruct them. It is the comparative freedom from a polemic purpose that makes the epistle what it is, the fullest statement of Paul's soteriological views. On the other hand it is a letter, not a theological treatise, and as a letter adapted to the needs of the church it includes references to the tendencies that were likely to penetrate wherever Jewish influence was felt. Moreover, as a letter it deals with the great matter of salvation by faith, not abstractly, but in vital and personal fashion.

2. *The theme of the epistle, so far as its doctrinal contents (chaps. i.-xi.) are concerned, is given in chap. i. 16: The gospel "is the power of God unto salvation to every one that believeth; to the Jew first, and also to the Greek."* The next verse shows that justification by faith is an essential part of this statement; but the theme is a wider one; salvation by faith to all classes. The three leading ideas, presented in varied order and relations, are these: universality, grace, and faith. Salvation is for all classes, therefore, it must be of grace, and hence is accepted by faith; or being of faith, it is of grace, and hence universal. The three ideas enter everywhere, and always in vital relation, distinguishable, but not divisible from each other.

3. *The contents of the epistle.* Accepting the usual division into didactic (i.-xi.) and hortatory (xii.-xvi.) portions, it is only necessary to indicate the leading parts of the former. After the address, introduction, and theme (i. 1-17), we find four main divisions: (1) All men, Gentile and Jew, need salvation, for all are sinners; i. 18-iii. 20. Hence (2) righteousness from God (justification) is by faith, as the Old Testament indicates; iii. 21-iv. 25. (3) Thus men are saved; this is the power of God unto salvation; v.-viii. (4) Historically, it was for the Jew first, but also for the Greek, and despite the unbelief of the former, God's promise stands; ix.-xi. (It is to be noted that according to another analysis, chaps. iii. 21-v. may be regarded as treating of justification by faith, and chaps. vi.-viii. of sanctification by faith.)

It is clear to every one who accepts the exegetical method that Paul in the earlier part of his letter lays stress upon the way God accounts men righteous, and that he afterwards meets the objections arising from the ever recurring notion that such justification fails of resulting in actual righteousness. Midway between these two points the apostle inserts the remarkable parallel and contrast between Adam and Christ as representations of fallen and saved humanity. The relation in both instances is at once representative and vital. Hence chap. v. 12-21 is not an episode, but

leads the way to the discussion in chaps. vi.-viii., in which the gospel is shown to be the power of God unto salvation, over against sin (chap. vi.), over against the powerless law (chap. vii.), and as introducing a new life of the Spirit over against the life of the flesh. The term "flesh," here and in Galatians, is readily shown to be ethical, not merely referring to the physical side of man's nature; mistakes on this point have led to asceticism and to misapprehensions of Paul's anthropology. It is implied, though not directly asserted, that the life in the flesh stands related to Adam, the life in the Spirit to Christ. Human nature as a whole, turned away from God, constitutes the "flesh." The Holy Spirit renews this human nature and it becomes "spirit." Hence it is sometimes difficult to determine whether Paul refers to the personal Holy Spirit or to the renewed spirit in which the Holy Spirit dwells. This Holy Spirit is given to the justified believer, and thus he triumphs; nothing can separate him from the love of God. Chaps. ix.-xi. discuss with profound pathos the unbelief of the Jews, and rest the difficult problems on the sovereignty of God in chap. ix., but in chap. x. on the unbelief of the Jews. The prospective solution of the dark mystery is given in chap. xi.; the triumph of the gospel will yet be universal, ever of grace and by faith.

The practical exhortations have some reference to special matters, notably the scruples about eating (chaps. xiv.-xv. 13), which divided the Roman believers into "strong" and "weak," the former having no scruples, the latter disposed to judge their freer brethren. The principles here laid down remain of permanent validity. The conclusion of the epistle (xv. 14-xvi.) reverts to the apostle's plans of visiting Rome, and then follow (in chap. xvi.) a number of somewhat detached passages; greetings and doxologies. It is in this chapter that has occasioned the main critical question respecting the Epistle to the Romans.

4. The integrity of the epistle. The doxology (xvi. 25-27) is found at the close of chap. xiv. in one uncial MS. and in many cursives, and in both places in the Alexandrian MS. and a few others. No authorities omit chaps. xv., xvi., though Marcion rejected them. This variation in position, despite Schürer's assertion, is not sufficient to prove that the doxology is not genuine. The objection of Baur to chap. xv. is of no weight. That Paul wrote chaps. xv. and xvi. is well-nigh certain. But did they form a part of the Epistle to the Romans? Certainly this is by far the most probable view. No serious objection arises from the names occurring in chap. xvi. Priscilla and Aquila travelled a great deal, and the great number of acquaintances in Rome need occasion no surprise. The view that this chapter was a postscript addressed to Ephesus, intended for Phœbe, or as an appendix to a copy of the Roman epistle sent to that city, is plausible, but lacks proof. Bishop Lightfoot thinks a briefer form (without chaps. xv., xvi.) was sent to other churches, probably by the apostle himself. Other theories have been suggested, but the Roman destination of the entire epistle is in every way most probable, however the phenomena in the Greek text are accounted for.

II. *The Epistles of the Roman Imprisonment.*—This group consists of four letters: Ephesians, Colossians, Philemon, and Philippians; three of them undoubtedly written about the same time, and sent by the same person or persons.

1. The three epistles, Ephesians, Colossians, and Philemon, have been fully and fairly discussed in the BRITANNICA. The genuineness of all is defended; the place of writing has been assigned to Rome, not Cæsarea, and the questions of similarity, etc., handled with fulness and candor. The main perplexity grows out of the reference in Col. iv. 16 to "the epistle from Laodicea," and the absence of the phrase "in Ephesus" from the text of important MSS. in Eph. i. 1. The current opinion now is that the Ephesian letter was intended to be circulated in other churches, and

that this letter is referred to in Col. iv. 16. But that it was designed for Ephesus first seems on the whole most probable. These epistles give no indication of the previous conflict with Judaizers, and reveal a higher stage of theological thought, dwelling more on Christological and ecclesiastical truths. This would favor the view defended by Bishop Lightfoot, that they belong to the later period of the Roman imprisonment (see below), but the views here presented by the apostle do not of themselves prove this.

2. *The Epistle to the Philippians.*—The occasion, purpose, and contents of this epistle are fairly set forth in the BRITANNICA, but on two points supplementary statements seem called for.

(1) *The date.* Until recently this epistle was regarded as the last one written during the first imprisonment at Rome. But the influence of Bishop Lightfoot has made a change in the opinion of English Biblical scholars. He reverses the order, basing his argument mainly upon the resemblance of Philippians to Romans, and the advanced development in the church implied in the other epistles. On this we may remark, as in the similar question respecting Galatians, that the presence of the same thoughts and language does not establish nearness of date. The Epistle to the Philippians indicates a more fully developed church organization than do the others, and it is this, rather than the development (if it may be so termed) of the apostle's thought, that gives the most positive argument in regard to the time of writing. Bishop Lightfoot himself has shown the importance of this epistle for questions of church polity. (See his Dissertation on the Christian Ministry, *Commentary on Philippians*, pp. 181-269.) In favor of the usual view, despite his exceptions, there may still be urged the following reasons: (a) the enlarged condition of the Christian community at Rome; (b) the length of time called for by the various journeys alluded to in the epistle; (c) the companions of Paul at the time of writing; (d) the tone of the epistle, indicating a sense of weariness in captivity, etc. It is impossible to do more than name these reasons, which have been regarded by most scholars as convincing.

(2) The important Christological passage in chap. ii. 5-11 is deprived of much of its force in the BRITANNICA. The meaning is fairly given in the revised version, and most of those who are not prejudiced against the view commonly taken of the Person of Christ will accept the following paraphrase of Lightfoot (vers. 6, 7), as fairly explaining the apostle's statement: "Though existing before the worlds in the Eternal Godhead, yet he did not cling with avidity to the prerogatives of his divine majesty, did not ambitiously display his equality with God; but divested himself of the glories of heaven, and took upon him the nature of a servant, assuming the likeness of men." This paraphrase of Lightfoot accords with the rendering (and marginal notes) of the revised version, as can readily be perceived. The question respecting the phrase "emptied himself" (ver. 7) has been very fully discussed, and the phrase has given rise to the terms "Kenosis" and "Kenotists" as applied to certain views of the Incarnation. So far as the statement of ver. 6 is concerned, if we are in doubt as to the apostle's view here, we can scarcely trust the results of historical exegesis. It is quite unfortunate that the authorized version, by its faulty rendering ("thought it not robbery to be equal unto God"), has made it more difficult to explain the full force of the apostle's argument. The divinity of the pre-incarnate Word is far more fully set forth by the correct rendering: "counted it not a prize to be on an equality with God."

We may add that the genuineness of this epistle cannot be denied with any good reason.

The pastoral epistles have already been discussed (see PASTORAL EPISTLES). The present article has been made to cover only those epistles and questions that seemed to require supplementary remark.

Literature.—The *BRITANNICA* in the earlier volumes gives due attention to English and American works on the Pauline epistles, but the more recent volumes almost entirely ignore these. The fullest discussions will be found in the American edition of *Lange's Commentary*, New Testament (vols. v.-viii.). The articles in *Smith's Bible Dictionary* (Am. edition) are quite full on all the historical questions, and contain valuable lists of commentaries; P. J. Gloug, *Introduction to the Pauline Epistles*. For English readers there have been published a number of commentaries of a popular character, aiming to bring out the exact meaning of the epistles and to set forth the historical questions. Among them the *Speaker's* and those of Schaff and Ellicott rank high. An explanation of *Romans* by the present writer, based on the revised version, was published as a part of *International Revision Commentary* (N. Y., 1884).—For students of the Greek Testament may be recommended the Commentaries of Ellicott (*1 Corinthians, Galatians, Ephesians, Colossians, Thessalonians*, and *Pastoral Epistles* have already appeared); Lightfoot (*Galatians, Colossians, Philippians*); Godet (*Romans, 1 Corinthians*); C. Hodge (*Romans, Corinthians, Ephesians*); Vaughan (*Romans*), and many others. (M. B. R.)

ROME, a city of New York, half-shire of Oneida co. is situated on the Mohawk River, 15 miles west of Utica, at the junction of the New York Central, the New York, Ontario, and Western, and a railroad to Ogdensburg. Here, also, is the junction of the Erie and Black River Canals. It has a fine court-house, opera-house, 4 national banks, 1 daily and 3 weekly newspapers, 16 churches. The industrial works comprise iron, brass, copper, knitting, lumber, and other mills and factories. The town is handsomely laid out, with wide, well-shaded streets and flagged sidewalks. It is lighted with gas and has water-works. The total valuation of property is \$6,000,000. Rome was first settled in 1765, being at the portage between the Mohawk River and Wood Creek, which gave an outlet to the St. Lawrence. Here was Fort Stanwix, of Revolutionary fame, whose successful defence prevented St. Leger's division of Burgoyne's army from invading the Mohawk Valley. During the siege the battle of Oriskany (6 miles east) was fought August 6, 1777, in which Gen. Nicholas Herkimer was killed. Rome received a city charter in 1870. Its population in 1880 was 12,194.

ROMERO, MATIAS, Mexican diplomatist, was born at Oaxaca, Feb. 24, 1837. After commencing the study of law there he was admitted to the bar in 1857 in the city of Mexico. He attached himself to the party of Juarez, who employed him in the office of foreign affairs. In December, 1859, he was made secretary of the Mexican legation at Washington, and afterwards became chargé d'affaires. In May, 1863, he went to Mexico on the French invasion, and became chief of staff to Gen. Porfirio Diaz, but returned to Washington a few months later. After the defeat of Maximilian's attempt to establish an empire Romero negotiated several important treaties with the United States. In August, 1868, he was made minister of finance in Juarez's cabinet, but was obliged to retire from this post by ill-health. After some service in the Mexican Congress he resumed charge of the finances in 1876 under Pres. Diaz, but retired again in 1879. He was afterwards postmaster-general for a brief period, but in 1881 he became general superintendent of the Mexican Southern Railway, and accompanied Gen. Grant in his visit to Mexico. Romero was soon sent again as minister to Washington, especially to adjust boundary disputes, and in 1884 was reappointed by Pres. Diaz. During his long diplomatic service he has prepared many valuable reports on important public questions.

RONGE, JOHANNES (1813-1887), leader of a German Catholic movement, was born Oct. 16, 1813, at Bischofswalde, Silesia. He was educated at the University of Breslau and studied theology there. In 1841 he was made chaplain at Grottkan, but was soon removed from this post on account of some publications in Saxon papers. He then became a teacher, but in 1844 he wrote a letter denouncing the exhibition of

the Holy Coat of Treves. The controversy excited by this caused Ronge to withdraw from the Roman Church and attempt to establish a German Catholic Church. His most effective supporter at first was Czerski, who was, however, less radical in views than Ronge, so that eventually they separated. Ronge's movement assumed a political aspect, and in 1849 he was compelled to flee to London, where he busied himself in introducing Fröbel's new ideas on education. In 1861 he was permitted to return to Breslau, but soon went to Frankfort, where he issued many pamphlets in behalf of a Reform-Union, in which Protestant rationalists were to be included. In 1873 he removed to Darmstadt and established *Neue Religiöse Reform* to propagate his views. He died Oct. 27, 1887.

ROON, ALBRECHT THEODOR EMIL, COUNT VON (1803-1879), German general, was born April 30, 1803, and after receiving a military education entered the Prussian army in 1821. He pursued the higher military studies from 1824 to 1827, and then became teacher of the cadets. Regularly advanced from grade to grade he became colonel in 1851, major-general in 1856, lieutenant-general in 1859. He had then charge of the mobilization of the army when Prussia was making ready to interfere in the war of Italian independence, though the work was cut short by the treaty of Villafranca. In December, 1859, he was called to the ministry of war, and in April, 1861, to the ministry of the marine, to which, in December, the former was joined. In the long struggle which ensued between the government and the Landtag Gen. von Roon supported with vigor the plans of King Wilhelm, and co-operated with Count Bismarck in carrying through the reorganization of the army. The Schleswig-Holstein campaign of 1864 and the Austro-Prussian war of 1866 gave full proof of his abilities, and the king honored him with the cross of the Black Eagle. Again in 1870 he displayed the same signal ability in the war with France, and the fiftieth anniversary of his entrance into the military service was celebrated with pomp at Versailles in 1871. On his return to Berlin he was made a count, but he resigned the ministry of the marine at the close of 1871. He had been for some time opposed to Bismarck's policy, by which Prussia, so long the leader of Germany, was to become simply a large state in a grand empire. Count von Roon was not disposed thus to sacrifice the position of Prussia, but the current of events was too strong for him. His military eminence was still recognized when he was made field-marshal, Jan. 1, 1873, and he was soon after made president of the Prussian cabinet, but in November he resigned his post and retired from public life. He died at Berlin, Feb. 23, 1879.

ROSA, EUPHROSYNE PAREPA (1836-1874), singer, was born at Edinburgh, Scotland, May 7, 1836. Her father was a Wallachian nobleman, and her mother Elizabeth Seguin, who afterwards became a noted singer. The daughter was trained for the operatic stage in Italy, and began her professional career at Malta in 1855. After tours in Italy and Spain she went to London in 1857, where her talent was found best suited to oratorio and concert. In 1863 she was married to Capt. H. D. Carvell, of the British army, but after his death, having lost her property by an unfortunate investment, she made an engagement with a concert company to perform in the United States. Her first appearance was at Irving Hall, New York, in September, 1865. In February, 1867, she was married to Carl Rosa, violinist and member of the same company. With him in 1869 she organized an English opera, which for three seasons made tours of the chief American cities. In 1872 she joined the Italian opera company formed at Cairo by the Khedive of Egypt. With her husband she afterwards made a tour in England, and, when about to return to the United States, she died at London, Jan. 21, 1874. Parepa Rosa was large in person and handsome in countenance. Her

voice was a soprano, with a compass of two and a half octaves.

ROSCHER, WILHELM, German political economist, was born at Hanover, Oct. 21, 1817. His university training was received at Göttingen and Berlin, and after habitating himself at the former he was in 1843 made professor extraordinary, and in 1844 professor ordinary there. In 1848 he was called to Leipsic, and has there continued to lecture. He was the originator and leading advocate of the historical method of national economy, which has steadily gained on the "philosophical" or *a priori* method long in vogue. This system is well described under **POLITICAL ECONOMY** in the **ENCYCLOPÆDIA BRITANNICA**, and its method is indeed the basis of that article. Economics are by it regarded as but one department of the larger science of sociology, but in vital connection with the other departments. The state and its industrial, commercial, and political development are but one side of the life of the people, while the other includes their art, literature, and other products of their civilization, and the study of the whole is essential to scientific investigation of any part. On entering his professorship in 1843 Roscher issued an outline of his views, which he afterwards developed in numerous publications of various kinds. These include *Umriss zur Naturlehre der Staatsformen* (1847); *Geschichte der englischen Volkswirtschaftslehre im 16. und 17. Jahrhundert* (1851); *Kolonien, Kolonialpolitik und Auswanderung*, of which several editions have appeared; *Ansichten der Volkswirtschaft aus dem geschichtlichen Standpunkte* (1855); *Die deutsche Nationalökonomik an der Grenzscheide des 16. und 17. Jahrhunderts* (1862). His most important work, however, is his *System der Volkswirtschaft*, which began to appear in 1854, and was completed by the third volume in 1881, while in the meantime several editions of the earlier volumes had been issued, and the author had supplemented it with his *Geschichte der Nationalökonomik in Deutschland* (1874).

ROSCOE, SIR HENRY ENFIELD, English chemist, grandson of the historian William Roscoe, was born in London, Jan. 7, 1833. From an early age he evinced an inclination for the physical sciences. When he graduated at the University College, London, in 1852, he took the prize in chemistry and became assistant to Prof. Williamson. In 1854 he went to Heidelberg and studied with the famous chemist, R. W. Bunsen. His most important research at this time was his measurement of the chemical action of light, for which he finally devised an automatic method. In 1857 he was made professor of chemistry in Owen's College, Manchester, where he succeeded in forming excellent, well-equipped laboratories. In 1870 he was made president of the chemical section of the British Association at its meeting in Liverpool. He has been an earnest advocate of technical education, and for many years delivered in Manchester a course of popular lectures on science. In 1878 the University of Dublin conferred on him the degree of LL.D. In 1880 he was chosen president of the Chemical Society, London. In 1881 he founded the Society of Chemical Industry. In 1882 he was made president of the Literary and Philosophical Society of Manchester. In 1884 he received the honor of knighthood. In 1885 he was elected to Parliament from South Manchester as a Liberal. His publications include *Lessons in Elementary Chemistry* (1866), *Lectures on Spectrum Analysis* (1869; 4th ed., 1885), and a *Chemistry Primer*, which has been translated into many languages. His most important work is the *Treatise on Chemistry* (4 vols., 1877-85), in which he was assisted by Prof. Schorlemmer.

ROSE is the common name of a genus of bushy and prickly shrubs, the type of the natural order *Rosaceæ*, which comprises many useful and ornamental plants. The cultivated rose, of which there are very numerous varieties, is the most highly esteemed of

garden plants for beauty and fragrance. All its varieties were formerly supposed to be derived from one species, but it is now believed that they represent several species. North America has many species of native roses with single flowers, as is generally the case with wild roses, but some of them of much beauty. One of the most interesting of these is *R. setigera*, the climbing or prairie rose. This sends up shoots of 10 to 20 feet high in a single season, and bears flowers of a deep rose color, and leaves with from 3 to 5 sharply serrated leaflets. The stems are armed with stout, nearly straight, prickles. It is the only American climbing rose, and is found on the borders of prairies and thickets from Ohio to Illinois, and southward to the Gulf States. In cultivation it has yielded many double-flowered varieties, known as Prairie roses, of which may be named the Queen of the Prairies and the Baltimore Belle.

The Swamp rose (*R. Carolina*) is a common species in low grounds from Florida to North Carolina and westward. It grows from 4 to 8 feet high, the stem bearing stout, hooked prickles. The rose-colored flowers are numerous, borne in corymbs. *R. lucida*, the dwarf wild rose, is another very common species, it being found in dry soils and



Prairie Rose.

on swamp borders from the Gulf States northward. *R. blanda*, the early wild rose, extends from Vermont to Pennsylvania, and westward to the Rocky Mountains. Its stem is nearly unarmed, its flowers of a light rose color. *R. lavigata*, the Cherokee rose, has a long, trailing, smooth stem, the branches being armed with stout, curved prickles. The flowers are large, solitary, and white. This species is common in cultivation, and is valued as a hedge plant from its quick growth, strength, durability, and beauty. The Rocky Mountain and Pacific coast region has six or seven species of native roses. Our naturalized roses include *R. rubiginosa*, the European sweet briar, a high-climbing plant, which affects road sides and thickets, and *R. micrantha*, the smaller-flowered sweet briar, which is found in eastern New England. The principal rose pests of the United States are the thrips, the rose-bug, the aphid, and the red spider. They may be eradicated by a strong solution of soap in water of 100° temperature, applied by syringing twice a week.

ROSEBERRY, ARCHIBALD PHILIP PRIMROSE, EARL, a British statesman, belonging to an ancient Scotch family, was born May 7, 1847. When he was four years old his father died, and he succeeded to his title in 1868 on the death of his grandfather. He had

See Vol. XX. p. 850 (p. 873 Am. Rep.).

been educated at Eton and Christ Church College, Oxford, but left without graduating. He had indulged in racing and other sports, and spent some time in travelling on the Continent. On entering the political field as a Liberal he became noted as a speaker. He took special interest in the educational affairs of Scotland, and he advocated a reform of the House of Lords. In 1871 he was lord rector of the University of Aberdeen, in 1874 he presided at the social science congress held at Glasgow, and in 1880 he was chosen rector of the University of Edinburgh. In August, 1881, he was made under-secretary of state for foreign affairs, and he held this office until June, 1883. In the Gladstone cabinet in 1886 he was secretary of state for foreign affairs. On March 20, 1878, he married Hannah, only daughter of Baron Rothschild.

ROSECRANS, WILLIAM STARKE, general, was born at Kingston, Ohio, Dec. 6, 1819. His father had served as an adjutant in the war of 1812. The son graduated at West Point in 1842, and entered the engineer corps. He was assistant-professor of engineering for some years, and in 1847 he took charge of the repairs at Fort Adams, near Newport, R. I. Resigning in 1854 he became a civil engineer at Cincinnati, and was engaged in coal-mining and kerosene manufacture. An explosion of kerosene caused such injuries that he was confined to bed for eighteen months. In April, 1861, he offered his services to Gen. McClellan as volunteer-aid, but in June, just after being appointed chief engineer of the State of Ohio, he took command of the Twenty-third Ohio volunteers. He led a brigade into West Virginia, and fought at Rich Mountain, July 11. His commission as brigadier-general, U. S. army, was made to date from May 16. He had command of the department of Ohio until September, when, by a new arrangement, his command was called the department of West Virginia. In April, 1862, he joined Gen. Buell's army, and at the siege of Corinth he commanded a division. After the capture of Corinth he had command of the Army of the Mississippi, and defeated Gen. Sterling Price at Iuka, Sept. 19, but let him escape. Price united with Van Dorn, but Rosecrans successfully defended Corinth against their joint attack. (See CORINTH.)

In October, 1862, the command of the Army of the Cumberland, then gathered around Murfreesboro, Tenn., was assigned to Rosecrans. On Dec. 31, 1862, his camp at Stone River was attacked by Gen. Bragg as a preliminary to an invasion of Kentucky. For a time the attacking force gained great advantages, but Rosecrans by great personal exertions rallied his shattered troops, and finally on Jan. 2, 1863, repulsed the Confederates, who had well-nigh achieved a victory the day before. (See STONE RIVER.) In the spring following Rosecrans was slow to take the field against Bragg, who was then at Shelbyville. Precious time was lost in making preparations, far beyond what the occasion required, against dangers in front and rear. But the real danger that the Confederate force then employed in watching and resisting Grant's operations against Vicksburg should be released to reinforce Bragg was comparatively neglected. It was not until the end of June, after frequent orders and remonstrances from Washington, that Rosecrans advanced to Tullahoma. Bragg had retreated rapidly, and a month later Rosecrans took Bridgeport on the Tennessee. The month of August was frittered away, and on Sept. 4 Rosecrans crossed the Tennessee to engage the large Confederate force, which had now been gathered near Chattanooga. The operations in this vicinity have been described under CHICKAMAUGA (*q. v.*).

In consequence of this defeat Gen. Rosecrans was relieved of his command by Gen. Grant, Oct. 16. In January following he was placed in command of the department of Missouri, during which the invasion of Gen. Sterling Price was repelled. After the close of the war Rosecrans received the brevet of major-general, but he resigned from the army March 28, 1867. In

the next year he was for some months U. S. minister to Mexico, and was afterwards Democratic candidate for governor both in California and Ohio. In 1881 he was elected to Congress from California, and served two terms. He was made register of the U. S. treasury in June, 1885.

Gen. Rosecrans' campaigns in Tennessee have been the subject of much military criticism, but the fair conclusion seems to be that, though he is a strategist of high order, and capable of drafting beforehand excellent plans of a campaign, he is deficient in the necessary force to carry them through in spite of moral and physical obstacles, and in the mental quickness to improvise new movements required by emergencies. In his subsequent political career he took several opportunities to vindicate his cause without materially altering the popular judgment. His character and career bear a marked resemblance to those of McClellan.

His brother, SYLVESTER HORTON ROSECRANS (1827-1878), graduated at Kenyon College in 1845, and became a Roman Catholic through William's example. He graduated at St. John's College, Fordham, N. Y., and received a doctor's degree at Rome in 1851. Returning to the United States with priest's orders he conducted a college at Cincinnati, and there edited the *Catholic Telegraph*. In March, 1862, he was consecrated and became assistant to Bishop Purcell, and in 1865 bishop of Columbus, Ohio. There he built St. Mary's cathedral, and carried on the ecclesiastical work with great vigor.

ROSENKRANZ, JOHANN KARL FRIEDRICH (1805-1879), a German philosopher, was born at Magdeburg, April 23, 1805. He studied at Berlin, Halle, and Heidelberg, and became professor extraordinary at Halle in 1831. Two years later he was called to the University of Königsberg as professor, and he held this position until his death, June 14, 1879. He was a member of the ministerial council at Berlin in 1848. His literary activity was very great, and his field extensive. He began with a *History of German Poetry in the Middle Ages* (1830), and an *Encyclopædia of Theological Science* (1831). In explanation and support of Hegel's philosophy he published many works, of which the principal is his *Psychology, or Science of the Subjective Spirit* (1837). He also published *Pædagogik als System* (1843), which has been translated as *Philosophy of Education*. Other works are *Poetry and its History* (1855); *Science of the Logical Idea* (2 vols., 1858-59); *Life and Works of Diderot* (2 vols., 1866); a *History of Kantian Philosophy* (1840), which was the concluding volume of an edition of Kant's *Works*; and a *Life of Hegel* (1844) as a similar supplement to Hegel's *Works*. His latest work was *Neue Studien* (1877). His *Diary*, extending from 1833 to 1846, was published in 1854.

ROSENMÜLLER, ERNST FRIEDRICH KARL (1768-1835), German Biblical commentator, was born at Hesseburg, near Hildburghausen, Dec. 10, 1768. His father, JOHANN GEORG ROSENMÜLLER (1736-1815), was a noted Lutheran professor of theology, and published *Scholia in Novum Testamentum* (6 vols.), which passed through several editions. The son was professor of Oriental languages at Leipsic, and published *Scholia in Vetus Testamentum* (23 vols., 1788-1835). He afterwards assisted in the preparation of a Latin abridgment of this work (5 vols., 1828-35). He had also prepared a work on Biblical antiquities (4 vols., 1823-31). He died at Leipsic, Sept. 17, 1835.

ROSS, ALEXANDER MILTON, naturalist, was born at Belleville, Ontario, Canada, Dec. 13, 1832. While a boy he went to New York, and was a compositor in the office of the *Evening Post*. In 1851 he began to study medicine, and obtained the degree of M. D. in 1855. He then took an active part in anti-slavery agitation, and on the outbreak of the civil war in 1861 he was for a time a surgeon in the Union army. Later he served at Montreal as a confidential correspondent

of Pres. Lincoln. He afterwards became a member of the College of Physicians and Surgeons there, but devoted his attention chiefly to the natural history of Canada. In 1881 he was one of the founders of the Society for the Diffusion of Physiological Knowledge. He is now treasurer and commissioner of agriculture of the province of Ontario. His publications include *Recollections of an Abolitionist* (1867); *Birds of Canada* (1872); *Butterflies and Moths of Canada* (1873); *Flora of Canada* (1873); *Forest Trees of Canada* (1874); *Mammals, Reptiles and Fresh-water Fishes of Canada* (1878).

ROSS, GEORGE (1730-1779), signer of the Declaration of Independence, was born at Newcastle, Del., in 1730. He became a lawyer, and was chosen to the Pennsylvania Legislature in 1768. While still holding this position he was chosen to the First Continental Congress in 1774. He retired from Congress in 1777, and in April, 1779, was made a judge of the Pennsylvania court of admiralty, but died in July.

ROSS, JOHN (1790-1866), a Cherokee chief, was a half-breed, born in Georgia. He had acquired an English education, and rose to be principal chief of the Cherokees in 1828. The State of Georgia was then endeavoring to dispossess the tribe of their lands, and Ross stoutly resisted this movement, but a small minority of the tribe led by a Major Ridge were induced to consent to a treaty binding all to remove west within two years. Ross and over two-thirds of the tribe protested, and appealed to the President, but in vain. They were compelled to submit, and Gen. Winfield Scott succeeded in effecting the removal without bloodshed. The factions in the tribe continued, but Ross retained his position as principal chief. In 1861 he made a treaty with the Confederate States, and the Cherokees fought at Pea Ridge. But afterwards Ross joined the Union side. He died at Washington, D. C., Aug. 1, 1866.

ROSSI, GIOVANNI BATTISTA DE, an Italian archæologist, was born at Rome, Feb. 23, 1822, and was educated at the Roman College. He studied archæology under the learned Jesuit Marchi, and devoted himself especially to Christian antiquity. To Rossi's labors is due the exploration of the catacombs, the results of which appeared in his *Roma Sotterranea Cristiana* (3 vols., 1854-77), and in his *Bullettino di archeologia Cristiana*. He also published *Inscriptiones Christianæ urbis Romæ septimo sæculo antiquiores* (1861), and a handsomely illustrated work, *Musæi Christiani e Saggi di Pavimenti delle Chiese di Roma*. He is the president of the Papal Academy of Archæology, and is a member of many learned societies. He has contributed also to the department of classical archæology. His monographs and minor publications are numerous.

ROTHERMEL, PETER FREDERICK, painter, was born at Nescopack, Luzerne co., Pa., July 18, 1817. He was originally a land-surveyor, but went to Italy in 1836 and became a portrait-painter. Still later he devoted himself to historical painting. Among his works are Columbus before Queen Isabella, The Christian Martyrs in the Colosseum, De Soto discovering the Mississippi, Patrick Henry in the Virginia House of Burgesses. For the State of Pennsylvania he painted on a large canvas The Battle of Gettysburg.

ROUGÉ, OLIVIER CHARLES CAMILLE EMMANUEL, VICOMTE DE (1811-1872), French Egyptologist, was born at Paris, April 11, 1811. His father, a colonel, had intended him for a career in governmental service, but the revolution of 1830 broke up his plans. The son then resided on the family estate in Anjou until his love of philological study brought him back to Paris. After a general excursion in the field of Oriental literature he devoted himself to the investigation of Egyptian hieroglyphics for eight years. In 1844 his first publication attracted the attention of Letronne and Biot. In 1849 he was made keeper of the Egyptian Museum of the Louvre, of which he pub-

lished a catalogue. In 1854 he was obtained a position in the department of public instruction, and in 1860 he was made a professor of archæology in the Collège de France. He died at Bois-Dauphin, Dec. 27, 1872. His chief work is *Rituel funéraire des anciens Égyptiens* (4 vols., 1861-68). He published also a *Chrestomathie égyptienne* (3 vols., 1867-73), *Recherches sur les monuments qu'on peut attribuer aux six premières dynasties de Ménéthou* (1866) and various monographs. He maintained the Egyptian origin of the Phœnician alphabet in a memoir which was published by his son in 1874.

ROUSSEAU, LOVELL HARRISON (1818-1869), major-general, was born in Lincoln co., Ky., Aug. 4, 1818. His father was first cousin to Pres. W. H. Harrison, and died when Lovell was but thirteen years old. He had already left school, but afterwards studied law at Louisville, and was admitted to the bar at Bloomfield, Ind. In 1844 he was elected to the Legislature in that State and on the outbreak of the Mexican war he became captain in a regiment which fought under Gen. Taylor. On his return he entered the State Senate as a Whig, but he soon removed to Louisville, where he became conspicuous as a criminal lawyer. In 1860 as a member of the Kentucky Senate he took a firm stand against all movements tending to secession, and later against the proposed neutrality of the State. Raising two regiments of Union men, he formed "Camp Joe Holt" in Indiana, and when the time for action came led them into Kentucky. Having been appointed brigadier-general U. S. volunteers, Oct. 1, 1861, he marched in Buell's army to the battle of Shiloh, where he distinguished himself, April 7, 1862. For gallantry at Perryville, Ky., Oct. 8, 1862, he was promoted major-general, and at Murfreesboro, Dec. 31, 1862, he was again conspicuous. He fought at Chattanooga and Chickamauga, and in November, 1863, was appointed to command the district of Tennessee. Resigning two years later, he was elected to Congress, where he supported the reconstruction policy of Pres. Johnson. In 1867 he was commissioned brigadier-general in the regular army, and was assigned to the newly purchased Alaska, but in July, 1868, he was put in command of the department of Louisiana. He died at New Orleans, Jan. 8, 1869. He was noted for his physical strength and chivalrous courage.

ROUTH, MARTIN JOSEPH (1755-1854), English divine, was born at South Elmham, Suffolk, Sept. 15, 1755. He graduated at Oxford in 1774 and held various college positions, becoming finally president of Magdalen College in 1791, and retaining that office for sixty-four years. He edited some of Plato's Dialogues, Burnet's *History*, and *Scriptorium Ecclesiasticorum Opuscula* (1832). His chief work was a collection of the fragments of the Christian writers previous to the Council of Nice, *Reliquiæ Sacræ* (4 vols., 1814-18; revised ed., 5 vols., 1846-48). He died in his hundredth year, Dec. 22, 1854.

ROWAN, STEPHEN CLEGG, admiral, was born near Dublin, Ireland, Dec. 25, 1808. He was brought to the United States at an early age and received appointment as midshipman in the navy in 1826. He became lieutenant in 1837 and was engaged in the coast survey in 1838-40. During the Mexican war he had command of the sloop Cyane on the Pacific coast and took part in the capture of Monterey and San Diego in California, as well as capturing and destroying Mexican vessels. Under Com. Stockton he led a naval brigade in an expedition to the interior and received a slight wound. At the outbreak of the civil war he held the rank of commander and though his residence was at Norfolk, Va., where he had married, he remained faithful to the Union. With the steam-sloop Pawnee he performed efficient service on the Potomac and afterwards on the coast of North Carolina, where he conducted several expeditions until his waters were brought securely under Union control. He was made commodore in July, 1862, and afterwards had com-

mand of the New Ironsides off Charleston until the spring of 1864, when he was relieved. In 1866 he was made rear-admiral and took command of the Norfolk navy-yard. In 1868 he was made commander of the Asiatic squadron and received the rank of vice-admiral. He afterwards had charge of the navy-yard at New York, the naval asylum at Philadelphia, and the naval observatory at Washington. Since 1883 he has been chairman of the Lighthouse board.

RUBINSTEIN, ANTON, Russian pianist and composer, was born at Wechotynetz, Roumania, Nov. 30, 1830. He was taken to Moscow in childhood and early appeared in public as a performer. At the age of ten he went to Paris for instruction, but also performed at concerts, Liszt giving him advice and encouragement. Rubinstein visited England, Sweden, and Germany, and for a time studied composition in Berlin. Then he began to teach, and having returned to Russia was appointed pianist to the Grand Duchess Helena and director of the concerts of the Russian Musical Society. In 1868 he again visited Paris and London, achieving a brilliant success both as pianist and composer. In 1872 he made a tour in the United States and he has since devoted himself to composition. Among his operas are *Dimitri Donskoi*, *Les Chasseurs Sibériens*, *Lalla Rookh*, and *Nero*. His oratorio, *Paradise Lost*, has been performed with great success. *The Maccabees*, a sacred drama, was performed in 1878.

RUPFNER, HENRY (1788-1861), Presbyterian minister and educator, was born in 1788, and entered the ministry in 1813. After holding various pastorates he was made president of Lexington College, Va., in 1837. He exerted himself for the advancement of education and in 1860 he advocated the abolition of slavery in Virginia. He died at Kanawha, Dec. 17, 1861. He wrote a romance called *Judith Bensaddi*, and *The Origin and Practice of Monks* (2 vols., 1850).

RUMSEY, JAMES (1743-1792), machinist, was born at Bohemia Manor, Cecil co., Md., in 1743. He was employed in the construction of flour-mills and made various improvements in machinery. After the Revolutionary war several ingenious men directed their attention to this subject and soon there was discussion about the application of steam. Oliver Evans (*q. v.*), who had made great improvements in mills, invented the high-pressure steam-engine and endeavored to make a steam-wagon for ordinary roads. John Fitch (see *ENCYCLOPEDIA BRITANNICA*) invented a steam-boat, but by want of means was long delayed in bringing it into practical operation. Rumsey had in September, 1784, exhibited on the Potomac a boat moved by mechanical devices up-stream. Gen. Washington is said to have been present at the exhibition, but does not appear to have given it serious thought. Afterwards Rumsey introduced steam-power into his boat and obtained in 1787 a patent from the State of Virginia for steam-navigation within its waters. Evans obtained a similar patent from Maryland, and Fitch from Pennsylvania and other States. State jealousy and political feeling were greatly excited over the rival claims. Rumsey enlisted the aid of Franklin and published at Philadelphia a treatise on the application of steam. A Rumsey Society was formed at Philadelphia in 1788 in his behalf, and Fitch, rough in speech and appearance, lost public favor. Rumsey went to England, where he received some attention and built a steam-boat, which made a successful trip on the Thames. A few days afterwards he died at London, Dec. 23, 1792. Rumsey had obtained patents for steam-navigation from England and France, but his projects expired with him. It remained for Robert Fulton with the generous aid of Livingston to put in successful operation the ideas of his unfortunate predecessors.

RUSH, BENJAMIN (1746-1813), is appropriately recognized in the *ENCYCLOPEDIA BRITANNICA* as the Sydenham of America.

His son, **JAMES RUSH**, born at Philadelphia, March 1, 1786, graduated at Princeton in 1805, and adopted

his father's profession. According to the custom of the time, after receiving his degree from the University of Pennsylvania in 1809, he pursued further study of medicine in Edinburgh. After entering on practice in Philadelphia, he married the daughter of Thomas Ridgway, and thus acquired a princely fortune. His wife was long a brilliant leader of society, while he in later years preferred the seclusion of his library. His work on the *Philosophy of the Human Voice* (1827) was the first thorough discussion of its subject, and still has great value. His other writings were *Hamlet, a Dramatic Prelude* (1834); an *Analysis of the Human Intellect* (2 vols., 1865); and *Rhymes of Contrast on Wisdom and Folly* (1869), a satirical dialogue. He died May 26, 1869. By his will he left his estate to the Philadelphia Library, yet on such peculiar conditions that the wisdom of accepting it was doubtful. He had spent the bulk of the bequest in purchasing a full square of ground on Broad street and erecting a massive granite building, leaving a comparatively small sum for the purchase of books. The building is occupied by the Ridgway branch of the library, but the inconvenience of its location has prevented it from being of real benefit even to students. Dr. Rush's will requires the library to issue every ten years in the next half century an edition of his own writings to be sold at cost-price.

RUSH, RICHARD (1780-1859), diplomatist, brother of the preceding, was born in Philadelphia, Aug. 29, 1780. Graduating at Princeton in 1797, he entered in the study of law. His first noted case was his defence of William Duane who was charged with libel on Gov. Thomas McKean. In January, 1811, he was made attorney-general of Pennsylvania, and before the close of the year comptroller of the U. S. treasury. In 1814 he was appointed U. S. attorney-general, and he served for a time as secretary of state under Pres. Monroe, by whom he was sent as minister to England. There he negotiated several important treaties, especially that of 1818, relating to the North Atlantic fisheries and the North-eastern boundary. After eight years spent in this capacity, Rush was recalled by his friend, John Quincy Adams, who had risen from the secretaryship of state to be President, and wished to employ his services in the treasury. Three years later their names were joined on a presidential ticket, which failed of acceptance by the people. Rush then used his influential foreign acquaintance to obtain loans for the city of Washington and other places. In 1836, being appointed by Pres. Jackson to secure from the British courts the legacy of James Smithson to the United States, he obtained the full amount, \$515,169, which has been the basis of the Smithsonian Institution. In 1847 he was sent by Pres. Polk as minister to France, and remained until 1849. Returning to Philadelphia, he died there ten years later, July 30, 1859. In early life he edited the *Laws of the United States* (5 vols., 1815) and wrote many political articles. In 1833 he published his *Narrative of a Residence at the Court of St. James*, to which he added a second volume in 1845. A new edition appeared in 1873. He also published *Washington in Domestic Life* (1857) and his executors issued a volume of his *Occasional Productions* (1860).

RUSK, THOMAS JEFFERSON (1802-1856), politician, was born in South Carolina, but early removed to Georgia, where he became a lawyer. Full of restless energy, he joined in 1835 the movement for attaching Texas to the United States. He took part in the convention which in March, 1836, declared Texas independent of Mexico, and became its first secretary of war. He fought at San Jacinto and on him devolved Gen. Sam Houston's command, when the latter was wounded. After leading some expeditions against the Indians, Rusk was made chief-justice of the Supreme Court, but resigned in 1842. He presided in the convention which ratified the annexation of Texas to the United States and was then elected to the U. S. Senate.

Of this body he was a member for ten years, being also its president *pro tem.*, when he died by his own hand at Nacogdoches, Texas, July 29, 1856.

RUSKIN, JOHN, the most eminent English art critic, was born in London, Feb. 8, 1819. His father was a London wine-merchant, who accumulated an ample fortune, which John, his only son, inherited. The elder Ruskin was a man of considerable culture, with much love for and taste in art, which artistic sense early manifested itself in his son. He was in the habit of making commercial journeys throughout England, often taking his son with him, and in these excursions spent much time in seeking attractive scenery, studying fine architecture, and visiting notable collections of paintings, pointing out their excellencies, and doing his utmost to cultivate the intense love of nature and art which these teachings awakened in the boy. To the teaching of his mother, a strict Evangelical, Ruskin owed the strongly religious tendency of his mind, and also his love of literature, which she took every pains to develop. These careful instructions of his parents in art, literature, and morals went far to develop in early life his naturally artistic and devout inclinations, and laid the foundations of his later career. He remarks, concerning his early love of nature: "In such journeyings, whenever they brought me near hills, and in all mountain ground and scenery, I had a pleasure as early as I can remember, and continuing until I was eighteen or twenty, infinitely greater than any which has been since possible to me in anything. . . . Although there was no definite religious sentiment mingled with it, there was a continual perception of sanctity in the whole of nature, . . . an indefinable thrill such as we sometimes imagine to indicate the presence of a disembodied spirit." He spent much of his time in communion with nature, having no inclination for playmates, and describes, in a poem written at 9 years of age, the effect produced on him by a striking natural scene. His early literary inclination, indeed, was towards poetry, and he continued to write verses till his thirtieth year, but never excelled in this direction. His poems manifest fine imaginative and warmly sympathetic powers, but are deficient in the equally necessary qualities of form and expression.

In 1833 Ruskin entered college at Christ Church, Oxford, whence he graduated in 1842. While at Oxford he won the Newdigate prize (1839) by a poem entitled *Salsette and Elephanta*, describing the dawn of Christianity in Hindustan. During the same period he wrote, at the age of 16, some articles on geology, which were followed by a series of anonymous articles on "The Poetry of Architecture." His artistic studies while at college, in connection with his life-long study of nature, led him to the conception that art, as then cultivated in England, had been led aside from nature by blind dependence on classic models. To this was added the conception that the landscape paintings of Turner, which he had deeply studied, indicated the opening of a new and natural school of art; that this great painter had been treated with gross injustice by his contemporaries, and that he formed the proper model for the correction of the vitiated public taste. These views, adopted with impassioned earnestness, were to some extent incorrect. The powers of Turner had been appreciated by many, and for that purpose he cannot justly be said to have needed such a prophet as Ruskin. To defend his favorite painter against his critics the young enthusiast began a review article, which the native fluency of his pen quickly expanded to a volume. This was published in 1843 under the title, *Modern Painters: their Superiority in the Art of Landscape Painting to all the Ancient Masters. By a Graduate of Oxford.*

This anonymous work created an immediate and immense sensation in art circles, and among lovers of literature in general. While devoted largely to an ardent advocacy of the artistic merits of Turner's paintings, with a fervent espousal of the claims of this artist to

high consideration, it broadened out into a general criticism of modern art methods, and displayed a knowledge of the subject, and a deep study and intense appreciation of the beauties of nature, couched in a rich and flowing style, which could not fail to attract widespread attention. The work, indeed, did not become an authority with critics and connoisseurs, but its rhetorical brilliancy of style and eloquent descriptions gained it a host of admirers, while the summary manner in which it set aside the distinguished masters of the past in favor of Turner stirred the world of art to its depths. The hollowness of much that had been generally accepted was laid bare, and at one stroke it was made evident that a new departure must be made. As Wordsworth had inaugurated the era of naturalism in poetry, so Turner, under Ruskin's championship, was about to do so in art.

The publication of this initial volume was followed by several years of residence abroad, during which Ruskin devoted himself to the study of art in Italy, and especially in Venice, and greatly enlarged that wide knowledge of the subject which is manifest in all his writings. The first fruits of this extended study was a second volume of *Modern Painters*, entitled *Of the Imaginative and Theoretic Faculties*, in which he gives an elaborate critical survey of the works of the old masters, who are compared with the modern English landscape painters, much to the advantage of the latter. These volumes displayed acute analysis of the elements of truth in painting, with abundant examples drawn from ancient and modern art, that went far to cause a complete revolution in the creed of artists, and to send the devotees of the brush to nature for their inspiration. At intervals during the succeeding years three more volumes of *Modern Painters* appeared, the third being entitled *Of Many Things*; the fourth, *Of Mountain Beauty*; and the fifth, published in 1860, *Of Leaf Beauty, of Cloud Beauty, of Ideas of Relation*, etc. The author continued his study of the several elements of landscape art and his fervid championship of Turner, writing with a lucidity and brilliancy of style that went far to atone for many defects of his literary work.

During the publication of these volumes his art studies in Italy led to other works of great literary merit and artistic value. In 1849 appeared *The Seven Lamps of Architecture*, these lamps indicating the character that good architecture should possess, the spirit in which it should be produced, and the moral perfection it should illustrate. Then followed his eloquently written *Stones of Venice* (3 vols., 1851-53), which for poetical richness and vividness of expression forms one of the prose masterpieces of the century. In this, the era of development of Gothic architecture in Venice is upheld as that of domestic faith and national virtue; that of Renaissance architecture as a period of domestic corruption and national vice. Several minor works on art subjects appeared in this era of Ruskin's life, including a pamphlet on *Pre-Raphaelitism* (1851); a series of *Lectures on Architecture and Painting* (1853); *The Opening of the Crystal Palace* and *The Elements of Drawing* (1857), with a story for children, *The King of the Golden River*. Of these works, *The Elements of Drawing* is one of the most practically useful that has appeared from his pen, and while not altogether safe in its teachings is of the greatest value as a sketcher's companion.

Modern Painters has been characterized by an able writer as "undoubtedly the greatest critical treatise ever written on art," and to a degree on literature and nature. Ruskin is unquestionably at the head of English writers on art, despite his conceits and idiosyncracies, and his lack of philosophical generalization. No other English writer compares with him for extent of knowledge in this field of study, or for vividness and value of art criticism. The skill, erudition, zeal, honesty of purpose, and emotional earnestness displayed in his works are worthy of all praise, and though his

judgment is not infallible, his reputation as a critic has steadily increased, and his decision on an art subject is of the highest value. He declares that the laws of painting are as unerring as those of music and chemistry, and that any one who masters them has all that is necessary to make a capable critic. In his view a painter is great if by any means he has laid open noble truths or aroused noble emotions, and it matters not what he paints so that he paints honestly and truly, with love of virtue and hatred of vice; while the sum of all the qualities needed to the highest production in art is the sum of all the best powers of man.

Few writers have put their mental personality more fully into their works than Ruskin. Sympathetic and confidential, touched with egotism and responsive to every inward influence, it is impossible for him to stand outside his works, and his passing moods and changing convictions are expressed without thought of the contradictions which they frequently involve. For ease and beauty of style he has few equals in English prose literature, his sentences being stately in manner, richly ornate, musical, and eloquent, while an intensity of feeling and expression manifests itself in everything he writes. Yet in giving free vent to his emotional imagery he is heedless of logical consistency, so that there is much less of reasoning than of impassioned sentiment in his works. As a consequence there is great lack of system and of orderly unfolding of purpose, his matter often losing power by too many words, while his habit of putting down whatever enters his mind at the moment, however irrelevant, makes his books discursive and to some extent tiresome, despite all their charms of style. In the language of one of his reviewers his merits may be summed up in a few words. He is the critic, rather than the philosopher of art. He has the keenest sensibility to the influence of nature, observes with accuracy and at the same time with strong poetic feeling, few men being more alive to beauty or having studied its manifestations more diligently. His knowledge of the beauties of nature is applied to the study of works of art, and enables him to judge their comparative merits with rare taste and warm sympathy. As a judge he is positive and severe but enthusiastic, praising and blaming alike from the heart, yet apt to decree from momentary impulse instead of criticising from well-digested study, yielding to instinct rather than to reason in forming his judgments. Fortunately his instinct is usually apt to be correct, and his opinions as a rule defensible, but by no means always so, his works being full of extravagances both of thought and expression, and of opinions whose lack of cogency is covered up with grace of rhetoric. Despite his faults he is an active and fearless thinker, strong in his likes and dislikes, and an eloquent exponent of refined tastes and noble sentiments.

The Pre-Raphaelite school of art, developed by such British artists as Millais, Hollman, Hunt, and the Rossettis, about 1850, was largely instigated by Ruskin's early works, and aroused his deep interest. The title of this school is hardly a correct one. Its purpose was not to blindly copy the methods of the artists preceding Raphael, but like them to go to nature for inspiration, and escape that tyranny of the old masters which so long had prevailed. It was the inevitable revolt against the conventionalism of the schools and the spirit of naturalism, rather than of mediævalism, that instigated these artists as it had instigated Ruskin before them, though some degree of a new mannerism arose in both cases from the too close study of mediæval art. Yet the revival of interest in Gothic art, so strongly helped forward by Ruskin, was the necessary step of escape from the prevailing classic conventionalism, and of progress into that devotion to nature as the only true basis of art which has grown and is still growing therefrom. Ruskin is the prophet of this new dispensation in art, and has been undaunted in teaching and developing it.

Only a portion of Ruskin's contributions to art

study have here been mentioned. Other works and pamphlets on the subject, both before and after 1860, flowed from his pen, besides many review articles, while his numerous lectures have also been collected into book form. He gave a course of lectures on Gothic art at Edinburgh in 1853, was appointed professor at the Cambridge school of art in 1858, Rede lecturer at Cambridge in 1867, and held the Slade professorship of Fine Arts at Oxford from 1869 to 1879; in 1883 he was re-elected to the last-named professorship, but resigned in 1885 in consequence of the introduction of vivisection into the Oxford schools. In addition to his writings on art, Ruskin practised drawing and painting, and illustrated several of his own books, such as *Stones of Venice*, but as a painter displayed no special merit.

The new phase of Ruskin's life, which began in 1860, has subjected him to severe criticism, while his enthusiasm has not been tempered with worldly wisdom. Turning from the study of art to that of society, he came forward as a reformer in social science and political economy, and has since worked in this field with all the force and earnestness of his older labors in art, but with less of knowledge and judgment. His writings in this direction began with a series of articles on "Political Economy," contributed to the *Cornhill Magazine* in 1860. These have been followed by numerous works, many of them with fantastic titles, on the same general subject. Of these may be named *Sesame and Lilies* (1864); *The Ethics of the Dust* (1865); *The Crown of Wild Olive: Three Lectures on Work, Traffic, and War* (1866); *The Queen of the Air: Being a Study of the Greek Myths of Cloud and Storm* (1869); *Frondes Agrestes* (1875); *Fiction Fair and Foul* (1881); and *Arrows of the Chace* (1883). Magazine articles on political economy have since been published under the titles *Unto this Last*, and *Munera Pulveris*, while two lectures on the "Political Economy of Art" have been published as *A Joy for Ever*. Ruskin began in 1871 a series of monthly letters to workmen, under the title of *Fors Clavigera*, with the declared purpose of establishing a fund to rescue British workmen from the tyranny of machinery. This series of letters continued till 1884. The most interesting of his later publications is his frank and garrulous autobiography, *Præterita* (2 vols., 1886-87).

It must be said that Ruskin's labors in behalf of workmen has called forth no ardent response from the class they were intended to benefit, and that his crusade against machinery and desire to bring back the happy days of hand-work has met with contumely rather than assistance from the world of industry. The fact is that Ruskin's principles of political economy, while containing much that is wise and sensible, contain much also that is impractical and chimerical, while the new ideas which he has sought to instil into the minds of workmen have roused fierce opposition among employers, who look upon him as a dangerous radical, seeking to break down the existing industrial relations. His contributions on political economy to the *Cornhill Magazine*, indeed, raised such a fierce outcry that the editor was compelled to refuse their further publication. *Fraser's Magazine* then accepted them, but was likewise compelled to cease publishing them.

Ruskin, finding that his published utterances were not having the effect upon the political and industrial world that he desired, attempted next to put his own theories in practice, and demonstrate to the world that his views were well founded and capable of practical realization. He built a number of model houses for the poor in London, and in 1871 established St. George's Guild, an industrial society of which he became grand master. Its purpose was to reclaim a tract of waste land on which his views of labor might be realized, develop education and culture among agriculturists, and help the industrial poor to better their lot in life. The ordinary relations of capitalist and laborer, master and tenant, were here discarded, and

the views adopted were those in vogue in Florence in the fourteenth century, with some necessary modifications. They were largely communistic, and took in charge the health and education of the people, with special arrangements of supply and demand, accumulation and distribution of wealth. It is presumable that the laws and industrial conditions of St. George's Guild are those which Ruskin believes should be applied to the whole nation. If they were adopted every man, woman, and child would be a ward of the state, trained and compelled to move in the lines for which nature and education fitted them; food and clothing would be dispensed by state agents and sold at an established price; communistic relations would exist among the people; the mode of building houses and cities would be prescribed, and no city permitted to contain more than 25,000 persons; and co-operation of all for the good of each would be the ruling principle of society. In addition a fixed creed of religious, social, and political duties would be taught and enforced, in which all laws and orders of the monarch must be obeyed except such as appeared inconsistent with what each subject in his own conscience supposed to be the law of God.

There is much more of the same chimerical and impracticable tenor in Ruskin's theory of society, and though his purposes were instigated by a nobly unselfish desire for the good of man, his schemes have necessarily proved failures. They were based on an ignorance of human nature and a disdain of the practically established laws of society, and while in some of their conditions seeking to lead man forward centuries into the future, in others they sought to take him back centuries into the past. In his treatises on political economy Ruskin, in fact, writes as a moralist, not as a scientist, and is guided by feeling, not by reason. He cares little about the established laws of the science of society, but much for men and women, attacks existing conditions blindly, and proposes an order of society which it would be impossible to establish. He attacks, for instance, the principle of usury, and declares that loans should be simply repaid, to demand interest being in his view to take an unjust and immoral advantage of the borrower. He would have luxury and the possession of great riches forbidden by the state, and is particularly opposed to the prevailing theory of demand and supply, claiming that human duties and sympathies make such a law void. Man is in his view more than a figure in a sum, and he permits sentiment to set aside the principles of natural law. He abhors democracy, and follows Carlyle in his belief of the saving efficacy of a strong government. He wants a strong man to rule, and the masses to be taken care of by a paternal government, believing that the ballot in their hands is worse than misapplied, and is the cause of many of the evils that have come upon the working class. As one of his reviewers says, "he is trying with Mrs. Partington's broom to sweep back the ocean." Feudalism and absolutism are of the past, and the world has moved and is moving far beyond them to better and higher conditions. Ruskin sees the gorgeous show and knightly pretence of feudalism, not its baseness and corruption. He looks with the eyes of the poet only, not with those of the historical scientist, and sentiment in him is far more dominant than reason. The conditions of the modern world therefore meet with his strong disapproval; those of the past with his strong approbation. He finds serious fault with the railway system for its defacement of the scenery of England, and with the factory system for the blurring and blasting effects of its smoke. For similar reasons all modern industrial improvements meet with his reprobation, and the preservation of scenic effects and artistic conditions holds an important place in his ideas of political economy. In a like spirit he objects to go to America because it has no castles, and demands that there should be a special dress for each class in society. Ruskin's mental charac-

teristic of poetical sensibility and emotional enthusiasm, in fact, while consonant with success in art criticism, unfits him decidedly for scientific investigations, and in his social studies he has only perceived that something is wrong with the world, while quite incapable of reasoning out the true causes and proper cure for the malady.

Opposition and failure have made him petulant and querulous, and he has lost much of his influence by his fault-finding and spirit of contempt for what displeases him. He has grown, indeed, wrong-headed and wilful in little things, has criticised painters in such a spirit as to be brought into court to answer, and in many directions he has departed from reasonable moderation. In art he carries his zeal as a critic too far, makes the moral aim unduly prominent, and insists too strongly that only an artist of pure character and conduct can accomplish a great work. He is similarly too uncompromising a realist, and finds strong fault with external details, such as Raphael's clothing his apostles in the dress of Greek philosophers, unmindful of the fact that if they are made apostles in face and mien the dress is of minor consequence.

These are faults, yet they detract little from Ruskin's merits as an art critic. In spirit he is intensely and sincerely religious. The natural world is to him the divine world, and he loves nature not for its beauty alone, but as the tabernacle of the Divine Spirit. He is always true to his highest conceptions, always at war with the evils of a materialistic and money-loving age, and in all he writes a deep appreciation of the innate goodness and beauty of man and nature appears. Though he may not be a safe critic in the technical points of art, he is genuinely so in its underlying spirit, having a breadth of vision, a range of sympathy, and a just conception of truth in art which have enabled him to overthrow conventionalism and bring art back to nature for its inspiration.

In literature Ruskin has been much too diffuse for the reputation of his works. He has written so profusely that few have the time to follow him. His books need sifting, and few of them will live. Though his later works contain many of his best and maturer thoughts he will be probably known to the future by *Modern Painters*, *Stones of Venice*, and *The Seven Lamps of Architecture* alone. Yet he has had and will have an influence on thought not to be measured by the number of his readers, and like all great thinkers has done much to mould the thoughts of his generation and of those to follow.

For more than half a century Ruskin resided on the Herne Hill and Denmark Hill estates of his father. In 1875 he bought an estate at Brantwood, on Coniston Lake, on which he has since chiefly resided. His father left him the large fortune of \$785,000, of which he has but \$50,000 or \$60,000 left. Immediately on his father's death he distributed \$35,000 among relatives whom he deemed his father had overlooked, and the remainder of his vanished fortune has been spent in various plans for ameliorating the condition of the poor. As a man and an author he has lived up to his ideas, and well deserves even more than the appreciative remark from Charlotte Brontë: "Mr. Ruskin appears to me one of the few genuine writers, as distinguished from book-makers, of this age." (C. M.)

RUSSELL, WILLIAM HOWARD, war-correspondent, was born at Lily Vale, near Dublin, Ireland, May 28, 1821. He was educated at Trinity College, Dublin, and became a lawyer at London. He had already done good work for the *London Times*, and in 1854 was sent to report the condition of the British army in the Crimean war. He was the first war-correspondent and received little favor from the military authorities. His faithful exposures of the short-comings in the commissary and hospital departments produced a sensation in England, and led to important changes in their administration. Afterwards his graphic sketches of the battles and incidents of the long siege of Sebas-

topol established his fame in the field. He went to India during the Sepoy mutiny, and came to America in 1860 when secession was imminent. He travelled through the Southern States and reported fully their spirit and preparations for war. Taking up his residence in Washington he noted the outburst of Northern sentiment in behalf of the Union, and the formation of the Army of the Potomac. After Gen. McDowell had advanced to the field of Bull Run, Russell set out from Washington to join the army, but was overwhelmed with the dense mass of soldiers and civilians in full retreat. Instead of reporting the battle he reported the rout so graphically that when his published letter reached the United States he was dubbed "Bull Run Russell." He continued to report the movements of the war as he saw them at Washington, and was for a time with Gen. McClellan in camp. But as his reports seemed to give aid and comfort to the enemy, Secretary Stanton refused him permission to accompany McClellan in the Peninsular campaign and he returned to England. He was again employed in reporting the war between Austria and Prussia in 1866 and gave an excellent account of the battle of Sadowa. The German invasion of France in 1870, the visit of the Prince of Wales to India in 1875, the Russo-Turkish war of 1877, and the Berlin Conference of 1880 also employed his pen. He founded in 1858 the *Army and Navy Gazette*. His books are chiefly collections from his correspondence. They include *History of the Crimean War* (2 vols., 1857); *My Diary in India* (1860); *My Diary North and South* (1862); *Canada, its Defences, Condition and Resources* (1865); *My Diary in the East* (1869); *My Diary during the Last Great War* (1873), and *Hesperothen: Notes from the West* (1882). He has also written a novel and some minor works.

RUSTOW, WILHELM, German military writer, was born in Brandenburg, May 25, 1821. Having entered the army in 1838 he rose to be an officer of engineers. In 1850 he was indicted for publishing a work on the military condition of Germany and fled to Zurich. He was made a major in the Swiss army and in 1860 he took part in Garibaldi's expedition to Sicily. He translated the Greek military writers and was associated with Köehly in his history of Greek military art. He also discussed the campaigns of Cæsar and Napoleon, the Crimean and the Franco-German war of 1870. He published many technical works on military art of recent years, including a *Military Dictionary* (2 vols., 1859). His brothers, Alexander and Cæsar, also wrote military works of value.

RUTGERS COLLEGE. The establishment of this institution, originally called Queen's College, has been usually dated from a royal charter of 1770. Recent investigation, however, shows that "his Majesty's Letters patent and Charter or Royal grant" for Queen's College was secured from his excellency William Franklin, Esq., governor and commander-in-chief in and over the Province of New Jersey, on Nov. 10, 1766." Owing to certain injurious discriminations between the trustees residing in New Jersey and those in New York, authorized in this first charter, a second one was obtained in 1770; and the college went into actual operation at New Brunswick in 1771. It was the outgrowth of a desire on the part of its Dutch founders to perpetuate their distinctive theology and forms of worship, and was for many years under the patronage of the General Synod of the Reformed Protestant Dutch Church of America. Its object was to aid in preparing young men "for the ministry and other good offices."

During the Revolutionary struggle the British took possession of New Brunswick, burned the college building, and scattered the teachers and students. After a migratory existence, now at Millstone and now at North Branch, with a commencement held in 1788 at New Brunswick, the college was closed for a period of six years. Rev. Dr. J. R. Hardenburgh, who had from the beginning labored with indefatigable zeal to

secure subscriptions, became its first regular president in 1785, and continued in office until 1790. William Linn, D. D., an impassioned preacher in the Collegiate Dutch church, of New York city, assumed the presidency pro tempore from 1791 to 1794. Owing to financial embarrassments the exercises of the college were suspended from 1795 to 1805. At the latter date Rev. Dr. Ira Condict, who acted as pro-tempore president from 1794 to 1810, was instrumental in reviving the college and in securing the erection of the noble brown stone edifice now standing in the centre of the campus. John H. Livingston, D. D., a man of noble character, accurate learning, and commanding influence, was the second regular president, from 1810 to 1825. He was, however, mainly interested in the theological professorship which he held in connection with the presidency; so that he did little more in the college than "to preside on public occasions and sign diplomas." Financial distress and divided counsels led to a third suspension of literary exercises from 1816 to 1825. Philip Milledoler, D. D., LL. D., now became president, and the name of Queen's was changed to Rutgers College "in consideration of the character and services of Col. Henry Rutgers," a revolutionary patriot who contributed towards its endowment \$5000, at that time considered a large amount. Dr. Milledoler was distinguished for his fervent piety, catholic sympathies, and above all for his unctious in prayer that seemed akin to inspiration. The number of professors was increased, and the endowment enlarged to \$50,000. The kind of work done by the college during this period may be judged from the fact that in the class of 1836 occur the names of Joseph P. Bradley, LL. D., Associate Justice of the U. S. Supreme Court; George W. Coakley, LL. D., professor of mathematics in the New York University; Frederick T. Frelinghuysen, U. S. Senator, and Secretary of State; William A. Newell, M. D., member of Congress and Governor of New Jersey and Washington Territory; and Hon. Cortlandt Parker, LL. D., an eminent and successful lawyer.

From 1840 to 1850 the presidency was filled by Hon. Abraham B. Hasbrouck, whose lectures on Constitutional Law, genial manners, and generous hospitality contributed greatly to the prosperity of the college. A residence for the president was erected on the campus, and also a little later Van Neste Hall for the use of the literary societies and recitation-rooms. The latter structure was so named in honor of Abraham Van Neste, a liberal trustee. At the same time additions were made to the permanent fund.

Hon. Theodore Frelinghuysen succeeded to the office of president in 1850. He was a man of unusual wisdom and guilelessness; his disposition was naturally gentle and always pervaded by a thorough Christian spirit; his manners were conciliatory and his intellect was as discerning as his heart was upright. His influence, therefore, in settling a controversy that had been bitterly waged as to the relations of the trustees to the Synod of the Reformed Church was of the happiest nature. The feeling of loyalty to the institution extended through the entire denomination; students increased, and many \$500 scholarships were disposed of, making the endowment \$75,000. A year before Mr. Frelinghuysen's death the civil war broke out, causing a great decrease by enlistments and other distractions in the number of students; and at the same time as the income did not meet the salaries of the professors and the current expenses the principal of the endowment began to be seriously diminished.

With the accession of Rev. Wm. H. Campbell, D. D., LL. D., to the presidency in 1863, the college took a new departure in prosperity. By the payment of \$12,000 to the Synod of the Reformed Church the college regained its title to the campus and buildings, and became an independent literary institution on the condition that henceforth its president and three-fourths of the trustees should be members in full communion of the Reformed Church. Dr. Campbell

with an energy that overleaped all obstacles presented the claims of the college in the pulpits of the denomination and to individuals until he raised the sum of \$144,758; and on the occasion of the centennial celebration he made another great effort which resulted in subscriptions amounting to \$140,000. During his administration six new professorships were established, the number of students doubled, reaching at one time 200, and the following buildings erected: a large geological hall, an exceptionally beautiful chapel and library under one roof, an astronomical observatory, an addition to the grammar school more than doubling its accommodations, and certain useful structures on the experimental farm. These works tell their own story of diligent wisdom and render a well-earned fame secure. When Dr. Campbell resigned the trustees generously gave him an annuity of \$3000 for life.

The State College of New Jersey "for the benefit of Agriculture and the Mechanic Arts" was organized as a department of Rutgers College in 1865. It originated in a provision of Congress granting to the several States a certain quantity of the public lands to enable them to establish colleges, the leading object of which shall be to "teach such branches of learning as are related to agriculture and the mechanic arts, in such a manner as the Legislatures of the States may respectively prescribe, in order to promote the liberal and practical education of the industrial classes in the several pursuits and professions of life." The sale of the public lands allotted to New Jersey amounted to \$116,000, now invested in State bonds under the care of the State treasurer, and the income of which is paid to the trustees. Great credit is due to Dr. George H. Cook, the vice-president of the college, and who for many years had rendered invaluable services to the State, as the State geologist, for his energy and influence in securing the location of the State College at New Brunswick as a part of the scientific school of Rutgers already in existence. A farm of 100 acres is used with great success for conducting experiments in agriculture, the results of which are published for the benefit of farmers. Fifteen professorships ably manned afford instruction in four courses of study, viz.: one in engineering and mechanics, one in chemistry and agriculture, one in electricity, and one of two years in agriculture. The courses of study and discipline are under the management of the faculty and trustees of Rutgers, subject to the supervision of a board of visitors appointed by the governor, and consisting of two from each Congressional district. It provides fifty free scholarships, which are distributed among the counties according to population.

In June, 1882, Merrill Edwards Gates, Ph. D., LL. D., L. H. D., was inaugurated president of Rutgers College. Dr. Gates took this position with the prestige of unusual success as an educator while principal of Albany Academy. Since his accession the endowment has been still further increased by \$115,000 besides annual subscriptions pledged for a period of years amounting in all to over \$30,000, making the total income of the college about \$50,000; the library has received 14,000 additional volumes; the standard of scholarship has been raised both by new requirements for admission, and by a rigid insistence upon faithfulness in study and the maintenance of a high moral character as necessary to graduation; certain subjects in science treated in German and French textbooks have been introduced; physical development by appropriate gymnastic exercises have been made compulsory; the classical department has been reorganized and improved; new emphasis and impulse have been given to the pursuit of modern languages; several new professorships have been created, affording wider instruction in scientific subjects, such as electrical engineering, biology, mineralogy, etc.; more laboratory work with greater facilities of room and teaching has

been assigned to special students; and the number of students has grown from 116 to 193. In addition to his fruitful college labors Dr. Gates takes much interest in public affairs both as a speaker and a worker.

By act of Congress in 1887 an annual appropriation of \$15,000 was authorized for the agricultural colleges of each State, to be expended in carrying on and publishing investigations in the interests of agriculture; and by an act of the New Jersey Legislature in 1888 the sum of \$30,000 was appropriated for a laboratory for the agricultural experiment station located on the college grounds. The services of Dr. George H. Cook, who has always been devoted to the agricultural and industrial interests of the State, deserve in connection with these two acts the heartiest recognition. Rutgers College has a faculty of eighteen professors, but not a tutor, affording instruction in all subjects taught in other best American colleges. Its students, besides having their own society libraries and the college library at command, enjoy full privileges in the Sage Library belonging to the theological seminary, making altogether over 70,000 carefully selected volumes open for their consultation.

The trustees of the college have also an excellent grammar school fully equipped with teachers and a boarding department where sanitary arrangements receive special attention. (T. S. D.)

RUTH, BOOK OF. The article on this subject in See Vol. XXI. the *ENCYCLOPEDIA BRITANNICA* is p. 110 (p. 119 Am. Rep.).

document written soon after the period to which it refers," but was written at some unknown date, "long after the time of Ezra." In proof of this it is argued that Jewish tradition classifies Ruth, not among the prophetic writings, but among the Hagiographa as one of the Megilloth. But if this were fully admitted it would not prove that the tradition regarded Ruth as either late or non-prophetic in its origin: for the Jewish tradition attributes the larger part of the Psalms to David, Canticles and most of the Proverbs to Solomon, certain other Hagiographic writings to the times of Hezekiah, and, indeed, regards most of the Hagiographa as pre-exilic, and all of them as of prophetic authorship. The notion that the Hagiographa are mostly a collection of writings that were produced too late to be included in the legal and prophetic canons is wholly untenable. (See BIBLE and CANON.)

But the statement that Jewish tradition classifies Ruth among the Hagiographa, while partly true, does not convey the whole truth in the case. "The Septuagint, the Vulgate, and the English version make Ruth follow Judges." As a mere matter of classification, Ruth fits very well either of the two positions assigned to it. Which position is the correct one depends on the principle of classification followed. But there is no room for reasonable doubt that the arrangement that connects Ruth with Judges is the one which really represents the Jewish tradition as to the date and authorship of the book. The average reader would probably understand from the article in the *BRITANNICA* that the evidence of this is solely conjectural—that it depends upon the fact that by counting Ruth with Judges and Lamentations with Jeremiah the 24 books of the Hebrew canon "can be reduced to 22, the number assigned by Josephus and other ancient authorities." But this understanding of the matter is a mistake. The opinion that Ruth was counted with Judges and Lamentations with Jeremiah is not a mere conjectural way of accounting for the phenomena, but is supported by explicit testimony. Jerome specifically testifies to it, and evidently regards it as the preferable view, though he mentions the other classification of the books as being held by some. Origen directly and unequivocally says that the Hebrews counted Judges and Ruth as one book, and he recognizes no other view. The *Baba Batra*

informs us that Samuel is the responsible author of Ruth, as well as of Judges, and the books of Samuel. Josephus not only counts the books as 22, but he uses the Book of Ruth as a source of the history, in precisely the place where it stands in the versions, *Ant.* V. ix.

In opposition to this it is said: "It has been shown in the article on LAMENTATIONS that the argument for the superior antiquity of this way of reckoning breaks down on closer examination." But the only proof offered in the article referred to for the purpose of breaking down "this way of reckoning" is the fact that Origen also ascribes "the epistle" to Jeremiah. It is alleged that, by this indefinite term "the epistle," Origen probably meant a certain book that Jeremiah surely did not write, and that Origen's testimony is, therefore, not to be credited. But as this touches only the testimony of Origen, and not that of the other witnesses, and as no one would hesitate to believe Origen in the main, even if he is incorrect in a specification here and there, the attempt to "break down" the evidence is not a success. It is certain that all ancient tradition concerning the Book of Ruth connects that book with Judges and Samuel.

But several critical reasons are urged against accepting this tradition. It is said, for instance: "While it was very natural that a later rearrangement should transfer Ruth from the Hagiographa to the historical books, . . . no motive can be suggested for the opposite change." On the contrary, the character of the book, and the use made of it in the reading lessons, might very naturally suggest the placing of it among the Megilloth, with the other short books somewhat similar to it in character and use.

It is further alleged that the Book of Ruth shows no traces of "prophetic" or "Deuteronomistic" editing, and "has no affinity with the point of view which looks on the whole history of Israel as a series of examples of Divine justice and mercy in the successive rebellions and repentances of the people of God." Hence it is inferred that the book cannot have been known "at the time when the history from Judges to Kings was edited." These assertions need modifying; but so far as they are true of Ruth they are equally true of each of the five stories (*Jud.* xiii. 2-xvi.; xvii.-xviii.; xix.-xxi.; 1 *Sam.* i. 1-iv. 10; ix. 1-x. 16) that are grouped with Ruth in this arrangement of the historical books. The reason is evident in regard to them all. These stories are a different sort of literature from the narratives of public history with which they are connected. In them the interest lies chiefly, not in the facts of public history which they contain, but in the personal experiences of their heroes and heroines. This accounts for the relative infrequency of that class of authors' comments which would refer to the whole nation, rather than to the persons whose experiences are being sketched.

The statement that "the very designation of a period of Hebrew history as 'the days of the judges' . . . does not occur till after the exile," and the inference from it that Ruth i. 1 is post-exilic are alike incorrect. Neither this phrase nor any phrase fairly equivalent to it occurs in the post-exilic Hebrew of the Bible, save in 1 *Chron.* xvii. 10, where it is in a passage repeated from 2 *Samuel*. The phrase occurs substantially in the account given of King Josiah, 2 *Ki.* xxiii. 22, and the same idea is found in 2 *Sam.* vii. 11, and less sharply in many places in Judges and Samuel. The idea that by using the phrase the Book of Ruth "presents itself as dealing with times far back" is un-critical; the phrase would be appropriate at any time after the monarchy had been a few years in existence. It is an overstatement to say that the book "takes obvious delight in depicting details of antique life and obsolete usages." There is nothing to show that the writer thought of these details as either antique or obsolete. From the Biblical accounts it appears that David's conquests led to a sudden and considerable

change in the civilization of Israel—a change which exhibited itself in architecture, music, literature, and luxury of living, as well as in the revival of prophecy and of the ancient Mosaism. Especially when we have this fact in mind we see that all the details of old usages in the Book of Ruth are such as might naturally have been put on record by a writer who lived not later than the last years of David.

It is said that the author of Ruth views the period in which his story is laid "through the softening atmosphere of time, which imparts to the scene a gentle sweetness very different from the harsher colors of the old narratives of the Book of Judges." But in the nature of things there must have been peaceful, pastoral events in the times of the judges, as well as events of war and violence; and a skillful writer would picture each in the colors that properly belong to it. The circumstances that compelled Elimelech and his sons to live and die in exile have no "gentle sweetness" in them. Whatever difference there is in this respect between Ruth and the other stories of the times of the judges can be accounted for by the differences in the subject-matter. There is no need to suppose a long interval of time between the event and the author in order to account for them.

In fine all the external evidence goes to show that Ruth belongs to the group of writings, concerning which the *Baba Batra* testifies that Samuel the prophet wrote them, but that Gad and Nathan finished them. To this group belong also the Books of Samuel and Judges. These books, taken together, form a quite peculiar historical work, largely made by the process of putting together previously written parts, which is, in literary character, as distinct from the Books of Kings as it is from the Hexateuch. The tradition that Samuel wrote it is certainly capable of being understood in a sense in which it would be evidently untrue, but it is also capable of being so understood as to be consistent with probability. (See *JUDGES*, *KINGS*, and especially *SAMUEL*.) According to this evidence, therefore, Ruth was written within the lifetime of these three prophets, probably in the reign of David.

All the phenomena that appear in the book are consistent with this view. It would be difficult to establish by instances the statement that the language of the book is "post-classical." And in regard to its contents, Ruth, like *Jud.* xvii., xviii., xix.-xxi., etc., is a story of Bethlehem Ephrata, the home of David. It alludes to events up to the time when David reigned, and no later. It is written in the interests of monarchy, showing that the pre-monarchical times were often times of calamity even for good citizens. The motives for writing just such a work never would be stronger than they were in David's lifetime.

Similar considerations show that the book is to be regarded as historical, and not as a mere romance, however fit a romance like this might be to form a part of the Scriptures. Josephus certainly counted it historical, *Ant.* V. ix. So does the Book of 1 *Chronicles* in its genealogical lists, and so does the evangelist Matthew, *Matt.* i. 5. The historical character of the events also connects itself with the fact that David took his parents to sojourn in Moab, 1 *Sam.* xxii. 3, and with his acknowledgment of obligation to the Ammonite king, 2 *Sam.* x. 2.

The idea that the genealogical statement with which Ruth closes was borrowed from *Chronicles*, and added to Ruth by a later hand, is contrary to all the analogies of the relations of *Chronicles* with the other books, and is not sustained by the facts cited to prove it. It is, of course, true that the author of Ruth, *iv.* 5, 10, "clearly recognizes that Obad was legally the son of Mahlon," but it does not follow that he was not also the son of Boaz, nor that "from this standpoint the appended genealogy is all wrong." If Boaz had no nearer and preferred heirs of his own blood (and this seems to be the implication of the whole account),

then Obed was by the law his son as well as Mahlon's son, and the genealogy is consistent with the rest of the story.

Literature.—Good commentaries on Ruth are those of Dr. P. Cassel, translated by Dr. P. H. Steenstra, in the *Schaff-Lange* series, and of Dr. James Morison in the *Pulpit Commentary* series. (W. J. B.)

RUTLAND, a city of Vermont, county-seat of Rutland co., is at the junction of the Otter and East Creeks, at the foot of the loftiest peaks of the Green Mountains, Killington and Shrewsbury. It is 67 miles from Burlington and 84 miles north of Albany. Three railroads enter the town and have their repair-shops here. Rutland contains a U. S. court-house, the State work-house, 7 hotels, 4 national banks, 4 other banks, 2 daily and 3 weekly newspapers, 7 churches, 7 schools. The most important industry is the quarrying and working of marble, for which there are 4 mills and 7 finishing-works in Rutland besides those in West Rutland. There are also 3 foundries and railroad car-shops. Rutland was settled in 1770, and during the Revolutionary war, being on the frontier towards Canada, was protected by two forts. It was one of the capitals of Vermont from 1784 to 1804, and the State-house then erected is still standing. It was incorporated in 1847, and in 1887 the "towns" of Procter and West Rutland were formed out of part of the original "town" of Rutland. The village is lighted with gas and has water-works and a park. Its property is valued at nearly \$10,000,000. The population of the village in 1880 was 7502 and of the "town" 12,149.

RUTLEDGE, EDWARD (1749-1800), signer of the Declaration of Independence, was born at Charleston, S. C., Nov. 23, 1749, being a son of Dr. John Rutledge, who had emigrated from Ireland about 1735. He studied law with his brother John, and afterwards at the Temple in London. On his return he was chosen to the First Continental Congress, and in 1776 he was appointed a member of the Board of War. When the British began hostile operations in South Carolina Rutledge took command of a company of artillery. In 1780 he was captured at Charleston and remained a prisoner at St. Augustine for a year. After the evacuation of Charleston, in 1782, he returned home and served in the Legislature. He drew up the act abolishing primogeniture and advocated the adoption of the Federal Constitution. In 1798 he was elected governor of his State. He died Jan. 23, 1800.

His elder brother, **HUGH RUTLEDGE** (1741-1811), was judge of admiralty, member of the Legislature, and from 1791 till his death chancellor of South Carolina.

RUTLEDGE, JOHN (1739-1800), chief-justice of the United States, brother of the preceding, was born in Charleston, studied law at the Temple, London, and began practice in Charleston in 1761. His devotion to liberty is attested by his being a leading member of the Stamp-Act Congress in New York in 1765, and of the First Continental Congress at Philadelphia in 1774. In the latter he was pronounced by Patrick Henry the ablest orator. He was chairman of the committee which prepared the State constitution for South Carolina and became its first governor. By his orders Fort Moultrie was supplied with ammunition against the British attack in 1776. Though he had resigned in 1778, he was recalled to power the next year when the British invaded the State. When Charleston fell he retired to North Carolina, yet exerted himself to keep up the spirit of opposition and to aid the Southern army. In 1782 he was sent again to Congress, and

in 1784 was made State chancellor. He took a prominent part in the convention which framed the Federal Constitution, and in the State Convention which ratified it. In 1789 Washington appointed him an associate justice of the U. S. Supreme Court, but he resigned this position when elected chief-justice of South Carolina. Washington showed his high regard for his ability by appointing him chief-justice of the United States in July, 1795, and as such Rutledge presided at the next term. But on account of his action in the agitation concerning Jay's treaty with England, the Senate in December would not confirm his appointment. It soon became known, also, that his mind was impaired by disease. He died July 23, 1800.

RYAN, ABRAM JOSEPH (1839-1886), poet, was born at Norfolk, Va., Aug. 15, 1839. He was educated for the priesthood in the Roman Catholic Church, and after his ordination was a chaplain in the Confederate army. To the cause which that army represented he was passionately devoted, and when it was lost his lyric, *The Conquered Banner*, found an echo in the hearts of thousands in the South, while it elicited a response from Lord Houghton in England. Father Ryan went to New Orleans in 1865, and there, besides clerical duty, edited a religious paper. Afterwards he removed to Knoxville, to Augusta, Ga., and to Mobile, where he had charge of a church for some years. In 1880 at Baltimore he published a volume of his *Poems, Patriotic, Religious and Miscellaneous*, which had already separately had wide circulation. Thereafter he wandered restlessly from place to place in the South, sometimes lecturing and at intervals writing a *Life of Christ*, which was left incomplete at his death. He died at Louisville, Ky., April 22, 1886.

RYDBERG, ABRAHAM VICTOR, Swedish author, was born at Jönköping, Smaland, Sweden, Dec. 18, 1829. He graduated at the University of Lund in 1852, and became literary editor of a daily paper at Gothenburg in 1855. He published numerous romances which have been translated into English, and also various works relating to the Bible, in which he shows extreme rationalistic views. In 1870 he was elected to the Swedish Parliament from Gothenburg. In 1884 he was made professor in the high-school at Stockholm. Among his romances are *Freebooter of the Baltic* (1857); *The Last Athenian* (1859); *Adventures of Little Vigg* (1874); *Roman Legends* (1874). Among his other books are *Doctrine of the Bible on Christ* (1862); *Jehovah Worship among the Hebrews* (1864); *Pre-existence of Man* (1868); *Eschatology* (1880). He has also translated Goethe's *Faust* into Swedish and published *Poems* (1882) and investigations in *German Mythology* (1886).

RYLE, JOHN CHARLES, English bishop, was born near Macclesfield in 1816. His father was a member of Parliament and he was educated at Eton and Christ Church, Oxford, graduating in 1836 with honor. He was ordained in 1841, and became curate of Exbury, then rector of Helmingham in 1844, and vicar of Stradbroke in 1861. Although these obscure places seemed little fitted to give him reputation he soon became widely known as the writer of pithy, forcible tracts of unmistakable evangelical sentiment. In 1869 he was made rural dean of Hoxie, and in 1880 Lord Beaconsfield called him to be bishop of the newly founded diocese of Liverpool. He is an extreme Low Churchman. Besides his tracts, which have circulated by thousands, he has published *Expository Thoughts on the Gospels* (6 vols., 1856-59); *Plain Speaking* (1861); *Christian Leaders a Hundred Years Ago* (1865); *Bishops and Clergy of Other Days* (1869); *Church Reform-Papers* (1870).

S.

SABATIER, LOUIS AUGUSTE, a French Protestant theologian, was born at Vallon, Oct. 22, 1839. He studied theology at Montauban, and thereafter visited several German universities. In 1868 he was made professor of French literature in the normal school at Strasburg, and lectured there in the Protestant theological faculty. In 1873 he removed to Paris, and became professor in the newly-erected Protestant faculty. His writings include *Le Témoignage de Jésus-Christ sur sa personne* (1863); *Les Sources de la vie de Jésus* (1866); *L'Apôtre Paul* (1870); *Guillaume le Taciturne* (1872); *De l'Influence des Femmes sur la Littérature française* (1873); *La notion hébraïque de l'esprit* (1879); *De l'origine du péché dans la théologie de l'apôtre Paul* (1887).

SABBATH is the name in common of sundry periodic times of rest ordained in the Mosaic economy. A Sabbath of the land was appointed for every seventh year, when fields were not to be sown nor vineyards pruned (Lev. xxv. 4).

The yearly Day of Atonement, the yearly Feast of Trumpets, the first and the eighth days of the yearly Feast of Tabernacles were severally distinguished as Sabbaths (Lev. xxiii. 24, 32, 39).

But the name most frequently indicated the weekly rest of the seventh day, which had been earliest appointed, and by God himself, in commemoration of his own resting from the work of creation (Gen. ii. 3); and to this weekly rest-day of the Mosaic Scriptures the name "The Sabbath" is, in ordinary usage, applied. The name covers literally only the idea of rest. But the usage, as defined in the Mosaic law, included also the practice of religious duty, "Remember the Sabbath day to keep it holy" (Ex. xx. 8); and particularly of the great duty of public worship, "The seventh day is the Sabbath of rest, a holy convocation" (Lev. xxiii. 3).

This Biblical institution of a weekly religious rest-day has awakened immense interest and voluminous discussion, in regard to its origin, its ancient design, its history down to the time of Christ, and its standing with Him and His apostles. Yet its chief interest lies in a fact so important and so manifest that it supersedes all discussion: namely, that the observance of a weekly day of rest and religion has developed into one of the foremost factors of human welfare. Only the family and civil government are more conspicuously distinctive of Christian civilization. The ways in which this notable observance contributes to the advantage of individuals, of families, of communities, and of nations have been the subject of clear statement, and often of very extensive exposition, by a multitude of writers as diverse in their views concerning the divine claims of the usage as Luther, Hooker, Grotius, Paley, Thomas Arnold, Donville, Hesse, Dr. Norman McLeod, and P. J. Proudhon, socialist and atheist. But far more formal attestation of the fundamental importance of the usage has been given by that long array of the acts of legislatures and courts, especially in Great Britain and America, which is noticed below.

It is in these two unquestionable relations of the weekly rest-day, namely, to the Mosaic Scriptures on the one hand, and to the fundamental and enduring interests of mankind on the other, that writers have found the motives of that eager and sustained discussion of which the Sabbath has been the subject. Inasmuch as the developed importance of the usage has, with thinking men, admitted no question, if no more question had been raised concerning the

divine prevision and ordainment of such a day, two things would have attended upon the bare fact of the Sabbath institution: a most obvious and unanswerable argument for the divine origin of the Old Testament Scriptures, and equal argument for the permanent authority of an ordinance that was seen to have been aimed of God at such lasting effect. Upon both of these arguments, as absolutely fair and conclusive, a very large class of Christian writers have elaborately and confidently insisted.

Their opponents have had no resource but to deny the existence of any proof that the Old Testament rest-day was appointed by God as a usage necessary for men. Of such opponents there have been two chief classes. One of these, being truly reverent toward the Scriptures, have admitted the divine origin of the ordinance, but have claimed that it was a part of the ceremonial intended only for the nation of Israel and done away in Christ; so that the useful elements of the modern rest-day, however analogous to similar elements in the Sabbath of Moses, are held to be enjoined in no law of God. Of this representation it is an essential part that the early statement of the institution of the Sabbath, made Gen. ii. 3, where it fairly describes an appointment for the whole race, is nothing else than an anticipation by the historian, quite out of its date, of the narrow appointment to be long afterward made for Israel.

The other class of objectors have adopted more radical methods. As much of Old Testament text as connects the institution of the Sabbath with any choice of God, they set aside as unauthentic. Even then, however, the institution remains inwrought with writings so ancient that a philosophical objector feels bound to give some account of its presence there. This explanation is claimed to lie in the united facts that the Hebrews kept a festival of the New Moon; and that the intervals between the new moons (of 29½ days), when divided into quarters according to the successive "quarterings" of the moon would, most frequently, furnish periods of seven days. This theory has not attempted to show how lunar phenomena, thought to be distinct enough to effect the observance, now of a seventh day, now of an eighth, could have trained a people while still religiously intent on the phenomenon of the new moon, to override all phenomena in behalf of a strictly seventh sacred day. Such a substitute for the divine command being admitted, it would follow, of course, that the relation of the weekly rest-day to Christian worship and the world's advantage is a happy chance, involving no suggestion of the inspiration of Moses or of the authority of the Sabbath law.

In this relation of the opposing sides an element of the debate, as yet unnoticed, becomes of chief importance. The Mosaic Scriptures gave to the Sabbath so signal a preëminence above every other usage which they named as to predict and require its unexampled career. The Decalogue is by its form and contents marked off from all other writings, not only of Moses, but of all men. To moralists and philosophers of every class it stands as a fountain of law. Of the ten precepts that gave it name nine are accepted on all hands as of the essence of fundamental morality; the remaining precept being the law of the Sabbath. This collocation is the more remarkable by the fact that the Sabbath at that date, if viewed apart from its history and intended development, had no intelligible claim to be so advanced beyond all other Jewish usages. Nothing

short of the experience which the world has since had of its intrinsic relation to all practical morality and piety could ever have solved the wonder of its introduction into such a place. Then, when the ancient preface to the code asserts with unexampled formality and solemnity that God himself both framed and uttered it, and the subsequent narrative recites that God by a miracle recorded it, the contemporaneous assertion of a divine intent in the exaltation of the Sabbath law becomes complete. To this showing, however, response has been made, as by Paley in the statement: "That there are various passages in Scripture in which duties of a political, or ceremonial, or positive nature, and confessedly of partial obligation, are enumerated, and without any mark of discrimination, along with others which are natural and universal." He gives an example out of Ezekiel and another out of *The Acts (Moral Philosophy, Book V., Chap. 7)*. The offer of such an offset to the force of a document organized with the unexampled symmetry, precision, and solemn majesty of the Decalogue is held by the believers in a divine and enduring Sabbath law to be trivial.

In the time of Christ the Sabbath had come to be encumbered with such formalistic additions as to give great value to the example and instructions by which he swept them away. He taught that "The Sabbath was made for man and not man for the Sabbath," a saying which could never have been fully understood, but for the world's continuous and enlarging experience of those adaptations to humanity that lie in the Sabbath usage.

In harmony with this lesson of their Master, the apostles were careful to relieve all Christians, both Jewish and Gentile, from every element of Sabbath observance that savored either of Jewish formalism as later times had developed it, or of Jewish ceremony as it had unquestionably entered into the Mosaic appointment. The ceremonial seventh day, whether of Pharisaism or of Judaism, manifestly maintains no warrant under the explicit words of Paul, Rom. xiv. 5, 6, "Let every man be fully persuaded in his own mind. He that regardeth the day" (evidently the seventh day still kept superstitiously by Judaizing Christians), "regardeth it unto the Lord; and he that regardeth not the day, to the Lord he doth not regard it." No more did that ceremonial sacredness pass into any other day; but the "Sabbath made for man"—the ordinance of the weekly day of rest and worship which was never abolished, not even when side by side the seventh day of Judaism and the Lord's day of Christians respectively waned and waxed—stands to this day, sustained by these consistent and abiding sanctions: of God's first appointment of the Sabbath after the creation (afterward sufficiently, though incidentally, attested in patriarchal history); of his reinstatement of the ordinance after the abode in Egypt, first by the miracle of the manna, and then by his own voice and finger from Sinai; of the example of Christ in behalf of the weekly Lord's day, so soon as by his accomplished atonement Jewish ceremonies were all stripped away, leaving the indestructible substance of God's law for the race proclaimed in the Ten Commandments. In the double light of that law and of experience the Sabbath is a positive appointment of God, beyond invention by natural conscience, but binding to duty which is found to be so related to men's highest advantage of every sort that the appointment is a special attestation of God's rightful and loving government, and the obligation to obey is not formal but moral.

For the Jewish nation the Sabbath law was civil as well as religious. In Christian times the first civil recognition of the weekly rest-day was made by the Emperor Constantine, A. D. 321. To his

first statute additions were made by himself, and by Theodosius, A. D. 386. These laws prohibited such work as was not thought to be necessary, arrested military spectacles and heathen shows, and closed the courts. Additions were still made to them in the sixth century by the Eastern emperors. As early as the close of the seventh century similar laws began to be enacted by the Saxon kings in Britain. These met with additions and modifications under successive monarchs, until in 1676 was enacted under Charles II. the statute which, in substance, continues to be English law. From this sprang the laws of the several American colonies; out of which in turn have grown the present laws of the several American States. These, avoiding the mistake of requiring acts of worship, into which the spirit of their day led some of the colonial legislatures, are intent chiefly on forbidding unnecessary labor and traffic and the noisy amusements which would disturb public worship. In addition to these things, however, these American legislatures, especially, have given very noticeable attention to the opportunity which a weekly arrest of work offers to those businesses which supply temptation to dangerous appetites. Of the thirty-eight States now constituting the American Union thirty-six have Sunday laws. While all these provide against the sale of intoxicating drinks in so far as they are kinds of merchandise sold in shops, twenty-seven States make further express provision against the Sunday sale of intoxicants. The constitutionality of the so-called "Sunday laws" has been abundantly established in British courts and American.

Some protection of the weekly day of rest has been offered by French law, especially under the early emperors and by a statute of 1814, repealed in 1880.

The rest-day of Christendom is variously designated. In civil legislation and in such discussions and recitals as concern the civil and secular aspects of the observance it is commonly known as "Sunday," or "the first day of the week." Some Christians, notably the members of the Society of Friends, prefer to call it "First day." The New Testament has attached to it a name of obvious and peculiar significance—"the Lord's day" (Rev. i. 10)—a name which forbids all superstition or legalism, but doubly binds to essential duty. Since the enduring observance with its priceless advantages is to be traced straight back to the unchanging purpose and law of God, the ancient name lasts as long as the law, and now that the Judaizing superstitions that troubled the early Church have perished, the "Lord's day" is with all propriety called the "Sabbath."

(H. D. G.)

(For fuller discussion of the relations of the Sabbath to the Pentateuchal worship and institutions, see TABERNACLE.)

SABIN, JOSEPH (1821-1881), bibliophile, was born at Brannston, Northamptonshire, England, Dec. 9, 1821. He was for some years a bookseller in Oxford, but in 1848 he came to the United States, and ultimately settled in New York as an antiquarian bookseller and publisher. From 1856 to 1861 he pursued his calling in Philadelphia, but at the outbreak of the civil war returned to New York. As a bibliographer he had scarcely an equal, and such was his devotion to his specialty that he crossed the ocean twenty-five times in his hunt after old and rare works. He prepared catalogues of most of the valuable libraries that were sold at auction in his time in New York, among which may be specified those of Dr. Samuel F. Jarvis (1851), E. B. Curran (1856), G. B. Hazewell (1856), W. E. Burton (1861), Edwin Forrest (1863), John Allan (1864), and T. W. Fields (1875). Sabin republished on large paper limited editions of various old works illustrative of American history, and edited and published for sev-

eral years the *American Bibliophile* commencing in 1869. In 1867 he undertook the publication in parts of a *Dictionary of Books relating to America, from its Discovery to the Present Time*, of which he completed 13 volumes. He died at Brooklyn, June 5, 1881.

SACO, a city of Maine, in York co., is on the left bank of Saco River, six miles from its mouth, and 14 miles west of Portland. A bridge connects with Biddeford, to which it originally belonged, but being separated in 1762, it attained the dignity of a city a century later (1867). It has two national and two savings banks, an atheneum, a high school, ten churches, a public library, and a weekly newspaper. The industrial works comprise several large cotton factories, saw mills, machine shops, shoe factories, etc., which obtain water power from the falls of the river, which exceed 50 feet. The population in 1880 was 6389.

SACRAMENTO, the capital of California, and the seat of Sacramento co., is in 38° 33' N. lat., 121° 20' W. long., 33 miles by rail from San Francisco. The city is located on an extensive plain on the east bank of the Sacramento River, immediately south of the mouth of the American River. The streets are wide and cross at right angles. Those running east and west are designated by the letters of the alphabet, and those crossing them north and south are numbered, commencing at the Sacramento River. The business portion is built of brick, and the residence portion of wood. Shade trees are abundant, and almost every residence has a lawn and is surrounded with orange trees, palms, ornamental plants, and flowers.

The first railroad in California, extending from Sacramento into El Dorado co., was formally opened on Feb. 22, 1856. Work on the Central Pacific Railroad was commenced at Sacramento Jan. 8, 1863, by Gov. Leland Stanford, and this first overland road was completed May 10, 1869. Sacramento is on the line of the California and Oregon, Western Pacific, Central Pacific, California Pacific, and Sacramento and Placerville railroads. All of these roads are of the Southern Pacific system, whose shops here cover 25 acres of land and furnish constant employment to about 1800 men. The company's hospital is also located in the city. A line of steamboats runs to San Francisco on the Sacramento River and the bays, and another up the same stream to Red Bluff. The Sacramento River is spanned opposite the city by a railroad and wagon bridge, connecting it with the town of Washington, Yolo co., and the American River is crossed by two bridges. All the bridges in the county and all roads are free.

The capital of California was permanently located at Sacramento on February 25, 1854, and in 1869 the present capitol building, the finest in the State, was completed at a cost of about \$2,000,000. In the Capitol Park are the exposition pavilion of the State Agricultural Society and the State printing and electrotyping office, in which are printed, in addition to the usual work for the State, the textbooks for use in the public schools. The State Agricultural Society has also an extensive park for the exhibition of stock and a fine race-track. The State fairs are annually held in September. The Masons and Odd Fellows have each imposing temples. The United States Government has a post-office building which cost \$100,000. The County Court House (formerly used as the State Capitol) cost \$200,000, and a brick and iron Hall of Records cost \$50,000. The County Hospital, built on the pavilion plan, cost \$75,000, and can accommodate 175 patients.

There are in the city 1 national and 3 commercial and savings banks, 3 daily, 1 semi-weekly (German), 4 weekly newspapers, and 3 monthlies, and 17 churches. The Catholic Cathedral, now in course

of erection, will cost \$250,000. There are also 12 public-school buildings, 2 colleges, 4 private schools, and 1 art school.

The State Library contains 63,300 volumes; the Free Public Library of 12,000 volumes is maintained by a small city tax. The order of Odd Fellows maintain a library of about 8000 volumes. The Crocker Art Gallery is a brick and iron building three stories high, costing over \$100,000. It belongs to the city and contains some of the finest paintings in the State, together with an extensive cabinet of minerals, the property of the State. The paintings are valued at over half a million dollars. The State Capitol Park embraces 25 acres of land and the City Plaza 2½ acres. Both parks are lawned and planted with the choicest varieties of trees, shrubs, and flowering and ornamental plants, and fountains are appropriately placed. During the summer months semi-weekly open-air concerts are given at these parks by brass bands.

Sacramento is lighted with gas and electricity, most of the street lighting being furnished by the latter means. The water-works are the property of the city, and the water is supplied at a moderate charge.

The total valuation of property in the city is \$26,000,000, and the municipal debt on Jan. 1, 1889, was \$1,500,000. The municipal expenses for the year ending April 1, 1888, were \$517,555.78.

The city has 4 flouring mills, 4 planing mills, 2 box factories, 1 broom factory, 1 cannery, 2 wineries, 7 carriage manufactories, 2 spice mills, 3 potteries, and 5 foundries.

As in all cities in California the population is cosmopolitan. At present (1889) it contains 30,000 inhabitants.

In 1839 Captain John A. Sutter established a fort, now included within the city limits, but the city was not laid out until 1848, after the discovery of gold. The thousands of gold-seekers who arrived in the country came up the river to Sacramento in steamers and sailing vessels, and from that point proceeded by land to the mines. A canvas town was at first established on the river bank, and soon substantial buildings were erected. In 1849 the high waters overflowed the city, and levees were made. These however proved insufficient in the winter of 1861-2, when they were broken in the great flood and the city was again inundated. On Nov. 2, 1852, most of the business portion was burned, and again on July 13, 1854, a great fire swept over the same ground and destroyed all that had been rebuilt. The city is now protected with substantial levees against floods, and a paid fire department is maintained. The city was incorporated by the first legislature Feb. 27, 1850; on April 24, 1858, the governments of the city and county were consolidated; and on April 25, 1863, the present charter, providing for a city government only, was passed.

Sacramento is the commercial centre of a rich agricultural district, specially adapted to grape and orange growing. Its geographical position and transportation facilities enable it to command the trade of the entire northern half of the State.

(W. J. D.)

SACRIFICE. See TABERNACLE.

SACS AND FOXES. See FOX INDIANS.

SAFE DEPOSIT COMPANIES. Corporations for the safe keeping of valuable personal property, though of comparatively recent origin, are in operation in many of the large cities throughout the United States. Except in the State of New York, where their organization is provided for by general laws, they usually are created by special legislative acts, as was also the custom in that State until 1875, when a statute was enacted, authorizing the formation of stock companies for the purpose of taking

and receiving upon deposit as bailees, for safe keeping and storage, jewelry, plate, money, specie, bullion, stocks, bonds, securities and valuable papers of any kind, and other valuables, and guaranteeing their safety on such terms and for compensation to be agreed upon between them and their patrons. They were also authorized to construct and let out safes, vaults, and other receptacles necessary for the purposes of their business. Their affairs are managed by trustees, elected annually by the stockholders, the latter being jointly and severally liable for all debts to an amount equal to the par value of stock held over and above such stock. In the State of New York these corporations are under the supervision of the bank superintendent, to whom they make semi-annual reports and are subjected to annual examinations by him.

The Safe Deposit Company of New York, chartered April 15, 1861, with capital of one hundred thousand dollars, is said to have been the first distinct corporation formed for the sole purpose of safely keeping valuables and personal securities under guarantee, and the renting of fire and burglar proof vaults. January 1, 1888, the combined capital of the safe deposit companies of New York State alone was nearly three millions of dollars.

Prior to the organization of safe deposit companies, the vaults of banks of deposit and discount, particularly those located in cities, were burdened with boxes and valuable packages of stockholders and dealers to so great an extent as to be a source of serious inconvenience. Where such service was rendered by banks it was at best a disagreeable and unwilling one, involving risk without compensation, and the acceptance of trusts without responsibility. For this reason the forming of separate companies for the erection of substantial fire and burglar proof vaults on an extensive scale became necessary. The large capital employed by these corporations, ranging as it does from one hundred thousand to five hundred thousand dollars, admits of securing expert workmanship and the best of materials together with all improvements mechanical skill has devised for insuring strength and security in the construction of safety vaults, which are mostly built of combinations of metals such as welded plates of steel and iron, and homogeneous plates of hard and soft steel, Franklinite and chromic steel, etc., the quality of resistance lacking in one being supplied by the others. Not alone are the vaults securely built, but they are generally so constructed that they may be examined on all sides externally. The interiors are fitted up with tiers of safes and deposit boxes of sizes suitable for all requirements, enabling these corporations to offer their patrons not only a safe, but a safe within an impregnable fire-proof vault under surveillance of armed watchmen both day and night.

In books kept for the purpose are entered minute personal descriptions of their patrons together with mutually agreed upon private passwords to be used for identification. A person on renting a safe is furnished with the only key that will fit its lock, no two being alike. A safe-renter is not permitted to enter the vault until identified, nor can he open his safe without the assistance of a vault attendant, who first partially unlocks it to admit the key; various systems are employed by the different companies, such as the master-key and locked escutcheon covering keyhole. A safe-renter has the option of appointing a deputy to act in his stead, or of making one or more persons joint owners with himself. In the event of the death of a safe holder, no access is permitted to his safe, except on the production of legal authority, thus affording protection to the interests of lawful heirs.

Deposits may be made with these corporations in many forms and deliverable on such conditions as

may be agreed upon. Among others, by a person in his own name and for his individual account—in the name and for the account of another or others, of another or others with himself, deliverable wholly or in part, only to the party in whose name and for whose account deposited, or also to another; or if coupon bonds, and so desired, the bonds to himself alone and the coupons to another, or to either of several others as well as to himself, and then, if desired, only in the joint presence of two or more of them; a deposit may be made, delivery contingent, as "in escrow." A married woman may make, or have another make for her, a deposit in her own name, deliverable to herself only, or as she may direct; or a deposit of securities or valuables may be made under guaranty, the corporation assuming full and absolute liability for their value, guaranteeing safe keeping and delivery wholly or in part in accordance with the terms of agreement, whenever called for by the depositor or his legal representative. Safe-renters have access to the vaults as often as desired during business hours, and are furnished with private rooms in which papers or securities may be examined without fear of molestation. As a rule the officers and all employes of this class of corporations are pledged not to impart any information respecting their patrons, or of transactions had with them, except under compulsion of law.

The convenience and security combined with privacy and seclusion afforded by safe deposit companies has secured to them large and rapidly increasing patronage. (E. A. W.)

SAGINAW. See EAST SAGINAW.

ST. CLAIR, ARTHUR (1734-1818), pioneer and general, was born at Thurso, Caithness, Scotland, in 1734. He was a grandson of the Earl of Roslyn, and was educated at the University of Edinburgh. He had entered on the study of medicine with the celebrated surgeon, John Hunter, of London, when his receiving a large sum of money from his mother's estate in 1757, caused him to change his purpose and seek adventures in a military life. Purchasing an ensigncy in the 60th Foot he sailed with that regiment for America. Here he took part in the capture of Louisburg, and in 1759 being made lieutenant, distinguished himself under Wolf at Quebec. In 1760 he married at Boston Phoebe Bayard, a lady of Huguenot descent. He resigned his commission in 1762, and led a colony of Scotch settlers to the Ligonier Valley, Pa., where he had purchased a large tract of land. Here roads were cut, farms laid out, mills erected, and other improvements made. Besides holding various local offices, civil and judicial, St. Clair was a member of the proprietary council of Pennsylvania, and in 1775 he was made colonel of militia. Early in the next year resigning his civil offices, he led the Second Pennsylvania Regiment in the invasion of Canada. In this unfortunate campaign St. Clair's skill was displayed in helping to save Sullivan's army from capture. He was rewarded by promotion to be brigadier-general, Aug. 9, 1776. The rank of major-general was conferred Feb. 19, 1777, for his services at Princeton, and later when Burgoyne's army was threatening Northern New York St. Clair was placed in command at Ticonderoga. But he was compelled to evacuate this stronghold on July 4, since the British engineers had found means to gain the crest of Mount Independence and thus command the fort below. A clamor was raised against him, especially in New England, where the importance of Ticonderoga was greatly overrated. St. Clair was suspended from command until a court of inquiry could examine the case, yet he retained Washington's favor, and was a volunteer aide at the battle of Brandywine. The military court in September, 1778, declared that "Maj.-Gen. St. Clair is acquitted with the highest honor of the charges

against him." He was a member of the court-martial which condemned Major André as a spy, and was thereafter in command of West Point. He also assisted in quelling the mutiny of the Pennsylvania line, caused by their not receiving pay. St. Clair participated in the crowning glories of the siege of Yorktown and the capture of Lord Cornwallis. He remained in the South on military duty for two years later. On his return to Pennsylvania he again took part in the government, and in 1785 was sent to Congress, of which body he was president in 1787. In the next year he was appointed governor of the Northwest Territory. After making a treaty with the Indians at Fort Harmar in 1789, he established the capital of the Territory at Cincinnati, to which place he gave its name in honor of the society which had been formed by the officers of the Revolutionary army. Early in 1791 St. Clair was made general-in-chief of the army, and in the autumn he set out against the Indians of the Miami and the Wabash. He was, however, crippled with gout and had to be carried in a litter. Gen. Butler, second in command, was apprised on Nov. 3d of the approach of Indians, but did not communicate the fact to St. Clair, nor make any preparation. On the next morning the camp was surprised, and out of 1400 men 600 were lost. Congress investigated the case, and again St. Clair was pronounced the victim of circumstances beyond his control. He resigned his commission as general March 4, 1792, but continued as governor till November, 1802, when he was summarily dismissed by Pres. Jefferson. He retired to a small log-house on the summit of Chestnut Ridge, overlooking the valley of which he had once been proprietor. In vain he pressed the government for a settlement of his claims. The Pennsylvania legislature in 1813 granted him an annuity of \$400, and finally the U. S. government granted the veteran pioneer a pension of \$60 a week. He died at Laurel Hill, Pa., Aug. 31, 1818. He published a *Narrative of the Campaign of 1791* (1812). The publication of *The St. Clair Papers: Life and Public Services of Arthur St. Clair* (2 vols. 1882), edited by W. H. Smith, has placed in clearer light the merits of this general and the difficulties against which he had to struggle. (J. P. L.)

SAINT GAUDENS, AUGUSTUS, sculptor, born in Dublin, Ireland, March 1, 1848, was brought to New York when six months old. During 1861-66 he was a student, first at Cooper Institute, and then at the Academy of Design. He then went to Paris, where he studied for three years at the *École des Beaux Arts* under François Jouffroy. After a year spent at Rome, where his first work, *Hiawatha*, was produced, he returned to New York in 1872. He has since executed a number of notable works, of which the most important are *The Puritan*, a statue of Samuel Chapin (1887) in Springfield, Mass.; portrait statues of David G. Farragut (1880) in New York, Robert R. Randall (1884) at Sailor's Snug Harbor, Staten Island, N. Y., and Abraham Lincoln (1887) in Chicago; and portrait-busts of Wm. M. Evarts (1872-3), Theodore D. Woolsey (1876), and Gen. Wm. T. Sherman (1888). His statues are noted for vigorous and realistic treatment and their freedom from all conventionalities. (F. L. W.)

SAINT JOSEPH, a city of Missouri, county-seat of Buchanan co., is on the E. bank of the Missouri River, 110 miles above Kansas City, and 133 miles S. S. E. of Omaha. It is on the Chicago, Burlington and Quincy Road, which has branches hence to Kansas City, Council Bluffs, and other points. The Wabash, St. Louis, and Pacific Railroad, St. Joseph and St. Louis, St. Joseph and Grand Island, which connects with the main line of the Union Pacific Railroad, and St. Joseph and Des Moines (narrow gauge) are the other principal roads. The Missouri River is here crossed by a fine iron railway and foot

bridge, built in 1873 at a cost of \$1,500,000. It has 5 spans, one being a pivot-draw span of 365 feet. A few miles north another railroad bridge crosses the Missouri at Rulo, Nebraska. Among the principal buildings are the court house, city hall, high school, opera house, State Asylum for the Insane, and St. Joseph College. There are 32 churches, some having fine edifices; connected with the Roman Catholic churches are convents, parochial schools, and asylums. The see of the Roman Catholic bishop, formerly at St. Joseph, has been transferred to Kansas City. There are 21 public schools, including 4 for colored children. Five daily and 9 weekly newspapers besides other periodicals are published here. The streets have been greatly improved in recent years, \$158,600 being spent for this purpose in 1886. There is an efficient fire department. St. Joseph has 2 national, 1 savings, and 2 State banks. There are manufactories of stoves, architectural iron work, galvanized iron work, hardware, guns, wagons, carriages, brooms, furniture, beer, syrups, and clothing. The total value of the manufactures in 1886 was \$17,939,000. The wholesale trade for the same year was \$110,538,651. Pork-packing is largely carried on. St. Joseph was first settled by Joseph Robidoux, an Indian trader, who laid out the town in 1841. It was incorporated as a city in 1851, having already become noted as the starting point for the journey over the plains to the gold region of California. In 1859 the first railroad, the Hannibal and St. Joseph, reached this point. The outbreak of the Rebellion destroyed for a time the prosperity of the city. After the war the overland traffic, which had been diverted to other points, was slow in returning, but since the completion of its bridge, St. Joseph has regained a share of this commerce. Its population in 1870 was 19,565, and in 1880 it had increased to 32,431.

ST. LOUIS, the chief city of Missouri, is on the right bank of the Mississippi River, 20 miles below the confluence of the Missouri. It is 17 miles long by $6\frac{1}{2}$ in its greatest width, and its municipal limits include $62\frac{1}{2}$ square miles. It is laid out with generally straight streets, and in naming and numbering them the Philadelphia system has been followed. The U. S. census of 1880 showed a population of 361,704. Since that time no census of any kind has been taken, but the estimates for the past five years, from the most reliable sources, have given the following figures: 1884, 389,676; 1885, 406,530; 1886, 423,629; 1887, 428,358; 1888, 444,160. The increase is marked also by the number of new dwellings. In 1884 there were 2609 erected, valued at \$7,316,685; in 1885, 2670, valued at \$7,376,519; in 1886, 2223, valued at \$7,030,819; in 1887, 2490, valued at \$8,162,914.

The government of the city is still in the form of a municipal assembly, composed of a council of 13 members elected on a general ticket, and a house of delegates elected one from each of the 28 wards. The chief officer of the latter is the speaker. The elective officers of the city are the mayor, comptroller, treasurer, auditor, register, collector of revenue, marshal, coroner, sheriff, recorder of deeds, public administrator, the board of public improvements, and 11 assessors. The appointive officers consist, for the most part, of commissioners of water, streets, parks, sewers, health, and the harbor. The department of justice comprises, besides the supreme court of Missouri, the St. Louis court of appeals, a probate court, a circuit court, a criminal court, a court of correction, 2 police courts, and 14 justices of the peace. The militia consists of 4 companies, forming a battalion, and also 1 troop of cavalry. Besides the officers of the U. S. government usual in large cities, St. Louis has a quarter-master's department, an assayer, a Mississippi River commission, and the

See Vol. XXI p. 183 (p. 192 Am. Rep.).

cavalry depot at Jefferson barracks. The fire department consists of 26 steam engine companies, 4 chemical engine companies, and 7 hook and ladder companies. These are supplemented by an underwriter's salvage corps and the fire and police telegraph. The police department is controlled by the mayor and 4 commissioners; the State is divided into 6 districts, and the city police department is, virtually, a constabulary for the whole State of Missouri. 28 railroads centre at this point. The regular lines of steamboats up the Mississippi River number 4; to the lower Mississippi, 3; to the Missouri River, 2; and the Illinois River, 1. The number of street railroads in the city is 17. There are 3 hospitals, a morgue, an insane asylum, poor-house, work-house, house of refuge, 10 markets, 31 asylums and homes, 21 convents, 32 cemeteries, 8 boards of trade and exchanges, 23 banks and banking associations, 65 building associations, and 18 insurance companies, 2 of which are life companies. Besides the Public Library there are 14 libraries. The academies and colleges number 30; the public schools about 75, and the parochial schools about 80. The number of parks has increased to 22. The churches of the religious denominations number as follows: Baptist, 27; Christian, 4; Congregational, 14; Episcopal, 15; German Evangelical, 14; English Lutheran, 1; German Lutheran, 12; Hebrew, 8; Methodist Episcopal, 15; Methodist Episcopal (South), 9; New Jerusalem, (Swedenborgian), 3; Presbyterian, 26; Cumberland Presbyterian, 2; Reformed Presbyterian, 1; United Presbyterian, 2; Roman Catholic, 47; Unitarian, 3; miscellaneous, 19.

ST. PAUL, the capital of Minnesota, and county seat of Ramsey co., is on the Mississippi River, 2082 miles from its mouth. It is built on both sides of the river, which are connected by a fine iron bridge. The main part of the city is on

the second and third terraces from the river, but it occupies also the bottom lands along the river, as well as the upper plateau. The total area is nearly 14,000 acres. The estimated population in 1888 is 155,577, although as much as 185,000 is claimed. The new charter of 1888 gives the city 11 wards, and allows each to elect an alderman. A board of park commissioners has been created; and a board of education, consisting of 4 members, is appointed by the mayor to serve for two years. In 1887 \$12,000,000 were invested in new buildings, and the real estate sales were \$75,000,000. The assessed valuation of real estate is \$84,000,000. The bonded debt is \$4,162,421. During the year 1887 there were laid 55 miles of wooden sidewalks, 2 miles of stone sidewalks, 10 miles of asphalt pavement, and 14 miles of sewers. The fire department consists of 12 steam engine companies, 9 chemical engine companies, and 6 hook and ladder companies. The number of railroads is 12, of which the chief are the Chicago, Burlington, and Northern, the Chicago, St. Paul, Minneapolis, and Omaha, the Northern Pacific, the St. Paul and Duluth, and the St. Paul, Minneapolis, and Manitoba. The number of passenger cars transferred in the year is 260,000, and 20,000 passengers are in transit daily. Upon the Mississippi River the steamers carry 20,000 passengers, and 60,000 tons of freight annually. The jobbing trade has largely increased—the sales for the year 1888 being over \$100,000,000. Manufactures to the amount of \$35,000,000 are produced annually, giving employment to 20,000 men. Over \$3,000,000 are invested in the slaughtering and packing of meats. The enrollment of school children is over 12,000, and the number of teachers is 270; there are 25 public schools and 38 select schools and academies. The nucleus of a public library has been established. The new city and county building will cost \$1,000,000, and the new

opera house and hall of the Young Men's Christian Association are among the prominent features of the city. Many of the State institutions of Minnesota are located here. There are 12 asylums and hospitals, 17 banks and institutions, 8 boards of trade, and 3 regiments of State militia have their headquarters in the city. The cemeteries number 7. Nearly 70 newspapers and periodicals, daily, weekly, monthly, and quarterly, are published in St. Paul. The churches of the religious denominations number as follows: Advent, 1; Baptist, 11; Brethren, 1; Roman Catholic, 13; Christian, 1; Congregational, 1; Episcopal, 9; Evangelical, 3; Hebrew, 3; Lutheran, 14; Methodist Episcopal, 20; Presbyterian, 10; Reformed Episcopal, 1; New Jerusalem, 1; Swedenborgian, 1; Unitarian, 1; United Evangelical, 2.

SALA, GEORGE AUGUSTUS, English writer, was born in London in 1828, being the son of an Italian gentleman. Although he studied art, he has devoted himself to journalism and magazine writing. After being a contributor to *Household Words* and *Cornhill Magazine*, he established *Temple Bar* in 1860. As the correspondent of the *London Telegraph* he visited the United States in 1863, accompanied Napoleon III. to Algeria in 1864, reported the Paris Exposition of 1867, the German invasion of France in 1870, and Northern Africa in 1875. He travelled in Spain in 1875, in Russia in 1876, and in the United States in 1880. Among his books are *A Journey due North* (1858), relating to Russia; *Twice Round the Clock* (1859), sketches of London life; *Breakfast in Bed* (1863); *From Waterloo to the Peninsula* (1866); *Rome and Venice* (1869); *Cookery in its Historical Aspects* (1875); *America Revisited* (1882); various books of travel, and a novel or two.

SALEM, a city of Massachusetts, county-seat of Essex co., is on a peninsula in Massachusetts Bay, 15 miles N. of Boston, with which it is connected by the Eastern Railroad. Branch railroads run to Lowell, Lawrence, and other places. The harbor is good, but the trade is almost exclusively coastwise, and limited to coal and ice. Among the noteworthy institutions are the East India Marine Hall, Salem Athenæum, Essex Institute, and Peabody Academy of Science. The city hall, the courthouse, and Plummer Hall are important buildings, and there are many fine mansions erected in the era of commercial prosperity. There are 6 national banks, 2 savings banks, 2 weekly and 2 daily newspapers, 20 churches, good public and private schools, including a high school and a normal school. The industrial works comprise cotton mills, jute factories, tanneries, iron foundries, and shoe factories. Salem is lighted with gas, and has water-works and a park. Its property is valued at \$25,000,000, and its debt exceeds \$1,000,000. It was founded in 1628 by John Endicott, and in 1692 was the scene of the famous Salem witchcraft. After the Revolutionary war the enterprising merchants of Salem established commercial relations with India and China, and these were soon flourishing, but the war of 1812 deranged them, and Salem's foreign commerce thereafter steadily declined. The city was chartered in 1836. It is closely connected with the towns of Beverly and Peabody. Its population in 1880 was 27,563.

SALEM, a city of New Jersey and county-seat of Salem co., is on Salem Creek, 32 miles S. of Philadelphia. It is on a branch of the West Jersey Railroad, by which it is 44 miles from Camden. It has a court house, 3 hotels, 1 national bank, 3 weekly newspapers, 8 churches, 7 schools, and a collegiate institute. Its industrial works comprise 4 glass factories, 1 oil-cloth works, 4 carriage factories, 5 canneries, a foundry, flour and planing mills. It has gas and water-works, and many beautiful residences. It is surrounded by a rich farming country, the pro-

See Vol. XXI, p. 188 (p. 197 Am. Rep.).

duce of which is shipped here for Philadelphia, with which it has communication by steamboat as well as by railroad. The village was settled in 1673 by John Fenwick. In 1880 it had 5056 inhabitants.

SALEM, the capital of Oregon and county-seat of Marion co., is on the E. bank of the Willamette River, here crossed by a fine wagon bridge built in 1886 and costing \$50,000. It contains the State house, penitentiary, insane asylum, 12 churches, an orphanage, and schools for the blind, deaf, and dumb, which receive aid from the State. A good system of graded schools, an academy and the Willamette University, a Methodist institution, make provision for education. There are 4 newspapers, 3 of which issue both daily and weekly editions. The city has waterworks, electric lights, and an efficient fire-department. Wide streets, handsome houses, and several parks give it an attractive appearance. Two miles from the city are the State fair grounds. The adjacent country is a rich agricultural section, containing many garden and berry farms. Salem in 1880 had a population of 2538, but this is now estimated to have reached 6000.

SALISBURY, EDWARD ELBRIDGE, Orientalist, was born in Boston, April 6, 1814, and graduated at Yale College in 1832. After taking the theological course at New Haven, he went abroad and spent several years in studying Eastern languages, in Paris under DeSacy and DeTassy, and in Berlin under Bopp. Appointed in 1841 to the new chair of Arabic and Sanskrit at Yale, he devoted another year to study at Bonn before assuming his office. His Inaugural Discourse was privately printed in 1843. He endowed the professorship of Sanskrit and resigned it to W. D. Whitney in 1854, but continued to teach Arabic till 1856. His fine Oriental library, including part of that of DeSacy, was presented to Yale. He has been a member of the Asiatic Society of Paris since 1838, of the Imperial Academy of Sciences and Belles-Lettres at Constantinople since 1855, and of the German Oriental Society since 1859. He has actively served the American Oriental Society as corresponding secretary and editor of its *Journal* for some years; he became its president in 1863. He has contributed to the *New Englander*, and privately printed a monograph on the Diodati family (1875); a lecture before the Yale art school on *Principles of Domestic Taste* (1877); and three volumes of *Genealogical and Biographical Monographs* (1885-88). In the latter he has been assisted by his wife. His degree of LL.D. was conferred by Yale in 1869 and by Harvard in 1886.

SALISBURY, ROBERT ARTHUR TALBOT GASCOIGNE CECIL, MARQUIS OF, prime minister of Great Britain, was born at Hatfield, in 1830. He was educated at Eton and Christ Church, Oxford, graduating in 1853. He was elected a fellow of All Souls' College and entered Parliament in the same year as member for Stamford, being then known as Lord Robert Cecil. On the decease of his elder brother in 1865, he assumed the title of Viscount Cranborne, and in 1868 he succeeded to the marquise of Salisbury. He was an earnest defender of the Established Church, and a frequent contributor to the *Quarterly Review* and other periodicals. In July, 1866, he was appointed Secretary of State for India, but resigned in the following March, being unable to accept the Reform Bill proposed by Lord Derby. He returned to the same office, however, in Disraeli's cabinet in March, 1874. He was sent in November, 1876, as special ambassador to Turkey to arrange the difficulties respecting the Christian subjects of that empire. Although the ambassadors of the great powers united in proposals which were urged upon the Ottoman Grand Council, that body almost unanimously rejected them. The ambassadors then left Constantinople, and the Russo-Turk-

ish war soon began. In April, 1878, Lord Salisbury succeeded the Earl of Derby as Secretary of State, and soon accompanied the Earl of Beaconsfield to the Congress of Berlin in which the new division of the Sultan's dominions was settled. The two British negotiators shared in the ovations which followed their return to England from their diplomatic victory. But they went out of office together in April, 1880, after Mr. Gladstone's Midlothian campaign. In May, 1881, Lord Salisbury was chosen as leader of the Conservative party in the House of Lords. In 1886, when Mr. Gladstone's bill for an Irish Parliament at Dublin was rejected and his ministry came to an end, the government passed into the hands of the Conservatives, and Lord Salisbury became premier. Although his majority in the House of Commons was obtained only by the support of Liberal dissidents who regarded Mr. Gladstone's movement as threatening the integrity of the empire, he succeeded in maintaining a longer lease of power than seemed possible at first. The breach in the Liberal party has proved permanent, the two branches being known as the Gladstonians and the Unionists. Parnell and his followers act with the former, while the latter still give their support to the Conservatives.

SALMON. The *Salmonidae*, as now restricted, is not a large family of fishes, embracing See Vol. XXt. p. 221 less than 100 species, but in beauty, activity, gaminess, food qualities, and to some extent in size of individuals, certain members of the family stand first among fishes. The group embraces several genera, of which we are here concerned with two only, *Salmo*, the salmon of the Atlantic, and *Oncorhynchus*, the Pacific salmon. Of the genus *Salmo* the most important species, economically considered, is *S. salar*, the common Atlantic salmon, which frequents alike the coasts of Europe and America, and is one of the most esteemed of all food fishes. Individuals of this species are commonly from 10 to 12 pounds weight and about 30 inches long, but often grow much larger, a salmon weighing 83 pounds having been brought to London in 1821. The color of adults is a steel blue above, the sides and under parts being of lighter hue, the dorsal and caudal fins dusky, the ventrals and anal white, while a few rounded spots are scattered above the lateral line. In rivers the color darkens, the males being known as red fish, the females as black fish.

This species spends half its life in the ocean, though quite capable of remaining during all its life in fresh water, as is proved by its existence in land-locked lakes. The salmon of Lake Ontario are thought never to migrate to the ocean. The land-locked salmon is known as variety *sebago*, and differs somewhat from the migratory form. *S. salar* ascends the rivers annually to spawn. In the ocean it subsists on crustacea and their eggs, small shrimps, young crabs, etc.; in the rivers on small fish. It is supposed to eat little during its river residence, yet bites eagerly at the bait of anglers, and forms a favorite sportsman's fish. It ascends to the head waters of streams, leaping cascades and other impediments with great energy and persistence, and depositing its spawn in the sands or gravels at the river's head. For this purpose it digs deep furrows which it covers up after the eggs are deposited. A fish of 8 pounds is estimated to lay about 6000 eggs; one of 40 pounds, 15,000. The salmon are lean and unwholesome after spawning, but generally survive and return to the ocean. The young fish, which are known as parr, remain in the rivers from one to two years, and weigh but a few ounces when they pass out to sea.

S. salar is found in all the rivers of northern Europe, in America from Labrador to the Delaware River, and in the Great Lakes as far as Niagara. It

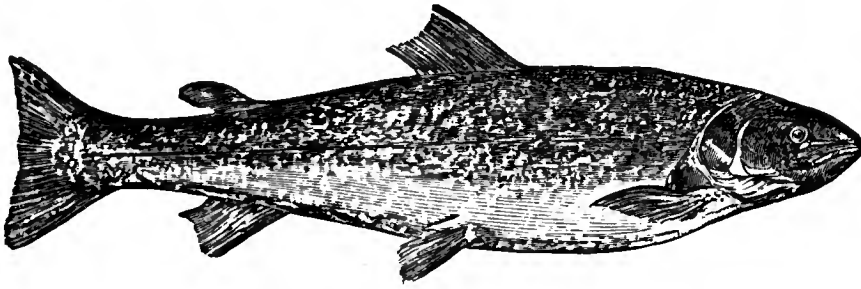
Salmon (*Salmo Salar*).

was formerly exceedingly abundant in all the rivers of the Atlantic slope north of the Potomac, but has been killed out by over-fishing and other causes, and is now practically unknown throughout that region. In early colonial days salmon were found in profusion in the Connecticut River, but by the injudicious devices of man they have been completely exterminated. A dam built in 1798 about 100 miles above the mouth of the river was the apparent cause of the extermination. The fish were unable to pass this obstacle and reach their spawning ground, and after a few years' despairing efforts abandoned the stream. The same has been the case with other rivers, and the salmon fisheries of the Atlantic coast are extinct. In 1850 the catch of Maine was valued at nearly \$21,000, that of Massachusetts at \$33,000, while not a fish is recorded as caught in any other Atlantic State. Measures are at present being taken to restock the rivers of those States, though with what success remains for the future to decide. In British America the catch is larger. New Brunswick's annual catch is estimated at a value of \$800,000. As many as 40,000 fish have been caught in one season at the mouth of the St. John River. The most of the salmon of this region are sent fresh to the United States. At the entrance to the Miramichi 400,000 pounds are annually put up for export. The yield here has greatly increased through protection to the fish during the spawning season. Salmon formerly abounded in Lake Ontario. In 1836 two men took 230 fish in 4 hours by spearing. Since then there has been a rapid decrease through the effects of factory waste thrown into the rivers. Salmon were formerly very abundant in the rivers of the British Islands, but have been killed out of the Thames and other streams by sewage. The greatest yield now is from Ireland.

The most valuable salmon fisheries now existing are those of the Pacific coast region of North America, where salmon were formerly so extraordinarily abundant that the rivers occasionally became choked with the multitudes of ascending fish. Man's injudicious industry has succeeded in greatly reducing the numbers of migrating salmon, though the fisheries are still of great importance and the annual catch of high value. The Pacific fish comprise several species of the genus *Oncorhynchus*, of which the largest and most valuable is *O. tshawytscha*, the quinnat or king salmon, as it has been well named. This species is the largest of the family, averaging in weight on the Columbia 22 lbs., on the Sacramento 16 lbs., but occasionally attaining a weight of from 60 to 90 lbs. It is found along the coast from Lower California to Kamtchatka, but most abundantly in the Columbia, where it is commonly known as the Chinook salmon.

The quinnat is a beautiful fish, its body being silvery in hue, the back, with the dorsal and caudal fins, being marked with round black spots. In the fall it becomes black or dirty red in color. As a food fish it is of unsurpassed excellence, its flesh closely resembling that of *S. salar* in flavor. It does

not feed in fresh water and dies after spawning, except perhaps in some of the shorter rivers. At the upper waters of the Columbia and other long streams the bodies of the fish appear bruised, the fins mutilated, the eyes injured, patches of white fungus on the body, while numerous parasites sap their strength. It is probable that all die immediately after spawning.

Fifty years ago this fish was hardly known; now it is eaten all over the world, being carried in cans and otherwise to all ports. The embryo fish are being transported to the principal northern countries of Europe, to Australia, and New Zealand, with the hope of adding this species to the food fishes of those regions. In its native habitat the annual catch is enormous. The Columbia River alone, during the six years ending in 1880, yielded nearly 200,000,000 lbs., with no serious diminution of stock. Yet that river is being fished with so little thought of the future that if the rate of destruction is continued its fisheries must become valueless before many years. Among the murderous devices adopted is that of the fish wheel, which throws the fish ashore in shoals, and permits scarcely an individual to escape. It is only the August and September run which now keeps up the supply. This is not molested, but the spring run is almost totally destroyed. It is doubtful if this amount of protection is sufficient, and other means need to be adopted to prevent the exhaustion of the fish. An efficient salmon hatchery is important for this purpose, and active efforts to restock the river in this way are now being made. In 1880 more than 1,500,000 fish were canned, being the largest number taken to that time. The Sacramento also yields abundantly, while the smaller rivers along the coast add to the grand total, the economic value of the quinnat fisheries exceeding that of all others combined on the Pacific coast. The total product of the salmon fisheries of the United States in 1880 is given at 52,000,000 lbs., of which Oregon yielded 39,500,000 lbs. To this may be added the catch of British Columbia, estimated in 1881 at 7,448,000 lbs., of a gross value of £894,000. The value of the United States canned salmon is given at \$3,255,365, this covering 31,453,000 pound cans. Since 1880 over-fishing has rendered the salmon industry much less profitable. (For some further particulars, see OREGON.)

In addition to their human enemies it may be stated that the salmon are destroyed in great numbers by foes of their own kind. In the rivers chubs, suckers, and other small fish devour the eggs and young, while in the ocean the mature fish find a dangerous enemy in the seals, which destroy them in multitudes.

There are several other species of *Oncorhynchus*, including *O. keta*, the dog salmon, which averages 10 to 12 lbs. in weight; *O. gorbuscha*, the hump-backed salmon, a small species; *O. kisutch*, the silver salmon, averaging 7 to 10 lbs.; *O. nerka*, the blue-backed salmon, averaging about 8 lbs. These all range along the coast from California to Kamt-

chatka, the last named reaching to Japan. *O. nerka* has a considerable run in the Columbia, and is the principal spring salmon of the Frazer River. It is the most graceful in form and handsome in color of all the salmon, and is an excellent food fish, its flesh being similar to that of the quinnat, but less firm and more watery.

The artificial propagation of salmon has been prosecuted actively of late years under the direction of the United States Fish Commission, which has established hatching stations at several localities. Probably the most important of these is that on the McCloud River, California. This hatchery, established in 1871, had by 1884 taken 67,000,000 eggs, most of which were distributed through the Union, though several millions were sent to foreign countries. About 15,000,000 were hatched at the station and placed in the several rivers of that region. As a probable result it is stated that the Sacramento catch has increased 5,000,000 lbs. annually for several years past. In 1888 about 5,000,000 fry were hatched at this station and placed in the Colorado and the shorter rivers of Oregon and California.

At the Bucksport station, Maine, about 2,500,000 eggs of the Atlantic salmon, *S. salar*, were taken in 1884, the fry being placed in the tributaries of the Hudson, Delaware, etc. About 1,000,000 eggs of the landlocked or Schoodic salmon (*S. salar* var. *sebago*) were taken and variously distributed. This activity in propagation cannot fail to have highly important results, and if in common with it efforts are made to provide proper fish-ways in our rivers and to prevent the influx of sewage, there is no reason why our salmon fisheries should not regain their former value. (For a consideration of other species of genus *Salmo*, see article TROUT.)

(C. M.)

SALMON, GEORGE, Irish clergyman and mathematician, was born at Dublin, Sept. 25, 1819. He was educated at Cork and at Trinity College, Dublin, graduating in 1839, and being chosen a fellow of the college in 1841. He had studied theology as well as mathematics and was ordained in 1844, but retained his fellowship until 1866, when he was made regius professor of theology in Dublin University. His mathematical works on *Conic Sections*, *The Higher Plane Curves*, *Geometry of Three Dimensions*, and *Modern Higher Algebra*, have been translated into several languages and have obtained for him the doctor's degree from both Oxford and Cambridge, as well as other marks of honor from scientific societies. In 1878 he presided in the mathematical and physical section of the British Association at its meeting in Dublin. His religious works consist of three series of *College Sermons* (1861, 1873, 1881), and an *Introduction to the New Testament* (1885).

SALT. This highly useful mineral substance is the chloride of sodium, being compounded of 60 parts by weight of chlorine and 40 of sodium. It is exceedingly abundant in the waters of the ocean, which contain in every 1000 parts 33.8 parts of saline substances, of which 26.8 parts are common salt. The ocean is estimated to contain in all 3,000,000 cubic miles of this substance, which has probably been washed from rock deposits during the long geological ages, its easy solubility facilitating this process. In its solid state it forms colorless, transparent, anhydrous crystals of the isometric system and with very perfect cubical cleavage, which generally displays itself in the great masses of rock salt. It occurs in the rocks most frequently in the condition of brine, though great deposits of rock salt are known, some of which have been mined for many centuries. The origin of rock salt is not very well understood. Some beds have been pro-

duced by the drying up of bodies of salt water cut off from the ocean, but in cases where the salt forms a perpendicular vein its origin cannot so easily be accounted for. As beds occur, however, in early geological strata this effect may have been due to rock-tilting forces. Lakes of brine yet exist in many regions of the earth, some of them doubtless due to cut-off bodies of sea water, others to salt springs, or the flow of underground water over deposits of rock salt, as in the case of the Great Salt Lake. Some of these lakes surpass the ocean in their percentage of salt, probably through the effect of evaporation.

The countries of Europe, with the exception of Norway, Denmark, and Holland, are supplied with salt from domestic sources, some of it being obtained from evaporation of sea water, while more generally the supply comes from salt springs and the mining of beds of rock salt. Of the latter the mine of Wieliczka, near Cracow, Austria, is the most notable instance. This mine is two miles long and one broad, and 1000 feet deep. Elsewhere in the Eastern Hemisphere, as in Russia, India, and China, salt exists in great abundance, the salt mines of the latter country being of great depth and very great number. Africa also is well supplied with salt, and the same is the case with South America, in which country the salt of Patagonia is largely exported to the remainder of the continent, it being of unusual purity and requiring no preparation for use. As a rule salt is vitiated by more or less impurity, sulphate of lime, oxide of iron, clay, and several other substances reducing the purity of rock salt, which needs considerable preparation to fit it for table use.

Salt abounds in the United States, ordinarily as brine, though several deposits of rock salt are known. Originally the supply of the colonies was obtained by evaporating the waters of the ocean, let in to shallow places along the coast and exposed to solar heat. What is now used is principally obtained from the waters of saline springs and wells, evaporated by solar heat or by boiling. The earliest worked and one of the most important of the brine deposits of the United States is that of the Onondaga district of Central New York, extending for a considerable area around the city of Syracuse. The whole middle portion of the State, indeed, seems underlain by salt in some form, the wells being unusually rich both in the quality and quantity of their brine. This district has yielded salt from an early period in the history of the country, and is worked to-day on an extensive scale, the salt water being pumped from numerous wells, and run into large vats or shallow reservoirs, where it is exposed to the evaporating action of the solar rays. There are more than 40,000 of these vats in use, besides several hundred factories in which the salt is obtained from the brine by boiling. The finest grades of New York salt are considered equal to the famous Ashton salt, of the mines of Cheshire, England. In several places beds of rock salt have been discovered during the boring of artesian wells. One of these, found in 1887 near Ithaca, at a depth of 2600 feet, is 250 feet thick. Such beds may be the origin of the brine elsewhere found. The salines of New York belong to the State, which at one time charged a considerable royalty for their use. At present the royalty is one cent per bushel, which no more than pays the expense of pumping, which is done by the State. The maximum product of the Onondaga wells was in 1862 9,053,874 bushels. It has since fallen off through the effect of severe competition from other States. The product in 1887 was 5,695,797 bushels. In the Warsaw district there were also produced in that year 6,072,000 bushels.

The salt deposits of the United States extend widely through the geological strata. Those of New York are in the Upper Silurian; most of those from

Pennsylvania to the Mississippi in the Lower Coal measures, while in Louisiana beds of rock salt occur in the Tertiary. The salt district of Pennsylvania is found along the Allegheny and other rivers of the western part of the State. The yield of those wells was over 1,000,000 gallons in 1860, but has declined since. West Virginia has important deposits in the valley of the Great Kanawha, which in 1870 yielded 4,633,750 bushels, though the yield here too has fallen off. In 1887 it was estimated at 1,125,000 bushels. In Southwest Virginia beds of rock salt occur, and there are brine wells of no great importance in this State and North Carolina. Ohio possesses some important wells, which in 1887 yielded 1,125,000 bushels. But the most important of our salt-yielding States is Michigan, whose salines are of remarkable richness. The wells of this State lie in the vicinity of Saginaw Bay. They seem inexhaustible in supply, and have been opened in considerable numbers, many of them being sunk to a depth of more than 1000 feet below the surface level of Lake Michigan, and some to 1900 feet. The Michigan wells yielded in 1870 3,106,760 bushels, in 1880 12,425,885 bushels, and in 1887 19,721,545 bushels. This very rapid development is due to the great strength of their brine, which is twice that of the New York wells, and more than twice that of the other States mentioned. The cheapness of fuel is also an important item. It is to this unequal competition with Michigan, and with the equally rich brines of Goderich, Canada, that the falling off in the produce of New York, West Virginia, Ohio, and other States is due.

Saline springs and salt wells are common in the valley of the Mississippi, being found in Illinois, Indiana, Kentucky, and Tennessee. West of the river they occur in Missouri, Arkansas, Nebraska, and Kansas, the latter State having valuable saline springs, rich in salt, in the valley of Solomon River. In Louisiana salt is also abundant. In the north-western part of the State are the "licks," so named from the habit of forest animals to resort there to lick the salt. They consist of springs of weak brine. Near the Gulf border of the State, on an island in a sea marsh near New Iberia, named Petite Anse or Avery's Island, is an immense deposit of rock salt of unusual purity. This salt is mined by the aid of a shaft sunk to the depth of 190 feet, and passing through 165 feet of solid salt. From the shaft chambers extend in various directions, they being 35 to 40 feet wide, and 65 feet high. Above them is a roof of rock salt 55 to 60 feet thick which is supported by columns of salt 42 feet square. The area of the mass is 144 acres, and its quantity of salt is estimated at 28,600,000 net tons. The production has increased from 25,550 tons in 1882 to 47,750 tons, valued on the spot at \$118,735, in 1887.

Through Kansas, Western Arkansas, Indian Territory, Northwest Texas, New Mexico, and Utah, extends a vast plain of Cretaceous age, in nearly every part of which salt lakes and incrustations appear along with vast masses of gypsum. Of these lakes much the most extensive and famous is Great Salt Lake, about 75 miles long and 30 wide, its waters containing 20.2 per cent. of common salt and 2 per cent. of other salts. Northward from this region, in the Rocky Mountain district, salt springs occur, and beds of rock salt of great extent and purity are reported in the Yellowstone Valley. In the southern part of Utah large deposits of rock salt are said to exist, their supply practically unlimited. Nevada is credited with deposits of extraordinary extent. On Virgin River, in the southeast part of the State, there is a bed of rock salt resting on granite which is said to extend as a bluff for more than 25 miles along the river, being in some places several hundred feet high. More than 60 per cent. of the entire cliff is rock salt of a purity of 90 per

cent. This remarkable outcrop is of a pale green color and ice-like transparency. Further up the river, on its west side, is a less extensive salt hill of a dazzling white color. These beds are not yet worked, the salt needed being obtained from saline springs and from an extensive saline marsh which deposits an incrustation of impure salt as fast as it is removed, several crops being obtained in a year. This is used in metallurgical processes. In Eastern Arizona is a shallow salt lake whose salt is precipitated by evaporation at one season, while salt water accumulates again at another season. The inhabitants bring their wagons here and help themselves freely. California has saline springs and salt marshes nearly as extensive as those of Nevada, but obtains its principal supply from the evaporation of sea-water in lagoons along the coast. The lagoons of the Bay of San Francisco yield not less than 25,000 tons annually. There is a very large demand for salt in this State as an aid in the reduction of silver ores and similar operations, which consume about 30,000 tons annually. The remaining States and Territories of the Pacific slope have abundant salt within their borders for local purposes. The United States indeed has an inexhaustible quantity of this important and necessary mineral, while the coast region affords many facilities for the obtaining of abundant supplies by the evaporation of sea water. The total product of salt in this country in 1880 was 29,805,298 bushels. Of this the great bulk came from four States, Michigan yielding 12,000,425; New York, 8,742,203; Ohio, 2,650,301; and West Virginia, 2,679,438 bushels. The total product for 1887 was 39,159,810 bushels, of which Michigan produced 19,721,545, New York 11,767,845, Ohio 1,815,000, Louisiana 1,705,465, Utah 1,625,000, and West Virginia 1,125,000. (C. M.)

SALT LAKE CITY, the capital of Utah Territory, and capital of Salt Lake co., is at the base of the Wahsatch Mountains, 11 miles from Great Salt Lake. The area of the city proper is about 12 square miles, but the corporate limits include about 50 square miles. Through it runs the Jordan River, and besides the water derived from City Creek Canyon and other streams for household purposes, a canal 25 miles long brings water from the upper part of the river for irrigation. The streets are 137 feet wide and the blocks 40 rods square. There are 13 miles of main water pipes, and about 12 miles of gas mains. The city is lighted by both gas and electric light. Places have been reserved for four or five large parks, but they have not yet been improved. The Utah Central, and the Denver and Rio Grande Railroads connect the city with the Union Pacific and the Central Pacific Railroad at Ogden. The Utah and Northern Railroad runs into Idaho and Montana. The other railroads are the Utah and Nevada, the Salt Lake and Western, the Bingham Canyon (narrow gauge), the Wahsatch and Jordan Valley. Street cars run to all parts of the city. The Western Union Telegraph Company gives communication with all the world, and the Deseret Company with the territorial towns.

The city government is vested in a council, composed of the mayor, five aldermen, one for each of the wards, and nine councillors, elected triennially. Great Salt Lake City was incorporated by the Assembly of the provisional State of Deseret, Jan. 19, 1851, and this Act was adopted by the legislature of Utah Territory in October of that year. Its bounds were enlarged in 1867 to include the district west of the Jordan, but in 1872 they were diminished on the southern side. In 1868 the name was shortened to Salt Lake City. It has been the seat of the territorial government since 1856, and has always been the most important city in the Territory commercially. It was settled by the Mormons under Brigham Young in July, 1847, after they had been

driven from Nauvoo, and was originally governed by an ecclesiastical council. The Mormon influence is still great, and the city is divided into 21 ecclesiastical wards. The finest public buildings are religious, including the Mormon temple, the tabernacle, a peculiar huge oval-shaped structure, accommodating over 7000 persons, and containing an organ, second in size only to that of Boston.

There are also fine churches of various denominations, including St. Mark's Cathedral. The building of Deseret University was finished in 1887, and there are other educational structures. St. Mary's Hospital is a handsome building. There are many places of public amusement, the chief being Salt Lake Theatre and the Walker Opera House. The Deseret Museum and Salt Lake Mining Institute show the vast mineral resources of the Territory. Manufacturing has only recently been commenced in Salt Lake City.

The Mormons have been industrious and their patient labor has effected a wonderful change in the natural condition of the city and vicinity. The exclusive policy which they pursued for many years has ceased, and the adherents of other religions are increasing in number. Evidences of the difference in religious belief abound on every side. The newspapers are ranged as Mormon and anti-Mormon. There are four daily papers which issue also weekly and semi-weekly editions, and there are two Swedish weekly papers. Some religious periodicals are also issued.

SALVINI, TOMMASO, Italian tragedian, was born at Milan, Jan. 1, 1830. He was educated chiefly by his father, who was professor of literature at Leghorn. His youthful predilection for the stage received encouragement, and he was trained for a time by the celebrated tragedian, Gustave Modena (1803-1861). Both his parents died when he was 15 years old, and in consequence he gave up theatrical study for two years. Then he entered the Royal Company at Naples, but left it to fight for Italian independence. He was afterwards engaged in the troupe of Domenico, with whom he spent six years. Then he retired for a year from the stage to give himself to serious study of the dramatic classics. His principal characters in Italian tragedy have been Egisto in Alfieri's *Melepe*, Paolo in *Francesca di Rimini*; in French, especially Orosmane in Voltaire's *Zaïre*; and in Italian versions of Shakespeare, Romeo, Hamlet, and Othello. In 1865 on the 600th anniversary of Dante's birth the four greatest actors of Italy were invited by the city of Florence to perform in Silvio Pellico's tragedy, *Francesca di Rimini*. The parts assigned were, to Madame Ristori, Francesca; to Salvini, Paolo; to Rossi, Lancelotto; to Majeroni, Guido. Rossi feared, however, that he would not be able at short notice to do justice to the part of Lancelotto, and Salvini, his senior, courteously assumed that part, and gave to Rossi the more important rôle of Paolo, in which he was already famous. The result was that Salvini played Lancelotto with such astonishing force as to attract marked attention to himself. The grateful city of Florence presented him with a statuette of Dante. Salvini visited the United States in 1874, and again in 1881. His personation of Othello especially was received with great enthusiasm. He played it at times in connection with Edwin Booth's rendering of Iago in English, and both actors shared the triumph of impressing an audience under such unusual difficulties. Salvini's last appearance in England was in 1884. The elements of his success may be summed up in his splendid physique, noble bearing, perfect elocution, dramatic power, and vehement passion. When in 1868 he performed in Madrid in *La Morte Civile*, the audience carried away with the intense realism of the death enacted before them rushed upon the stage to see if the actor were yet

alive. Salvini received the honor of knighthood from King Victor Emmanuel.

SAMARIA AND SAMARITANS. Samaria was the capital of the Northern kingdom of Israel, but Prof. W. Robertson Smith's statement that "while it stood, Samaria and not Jerusalem was the centre of Hebrew life" needs modification. The

Northern kingdom was larger than the Southern in territory and population, but its political importance and its position as to wealth and civilization varied at different periods. With the accession of Jehu, it became tributary to Assyria, while, so far as appears, Judah maintained her independence for some generations longer. Place as high an estimate as we may upon such kings of Israel as Omri, Ahab, and Jeroboam II., they do not make more of a figure than Asa, Jehoshaphat, Jehoash, and Uzziah. According to the Biblical accounts (and there are no accounts at all to the contrary), Jerusalem steadily maintained from the days of David a magnificence to which her northern rival never attained. The Northern kingdom had, indeed, distinguished prophets, but so had the Southern, and the Northern prophets paid a respect to the kings of the line of David such as we have no account of their own sovereigns receiving from the Southern prophets, *e. g.*, 2 Kings iii. 14, Hos. iii. 5, cf. Am. ix. 11. At various points in the history, and notably in the reigns of Jeroboam I., Baasha, Jeroboam II., and Hoshea, we have intimations that citizens in the Northern kingdom regarded Jerusalem as the religious centre of the worship of Jehovah, while there is no intimation that Samaria was ever so regarded even by her own citizens.

It is doubtless true that among the people and the religious sect that, in later times, were called SAMARITANS, there was a stronger admixture of the blood and of the traditions of the ancient Northern kingdom than such Jewish writers as Josephus are willing to admit; but this fact contradicts instead of sustaining certain conclusions drawn from it by Prof. Smith in the article in the *ENCYCLOPÆDIA BRITANNICA*. That article teaches that the priestly law in the Pentateuch "was first published by Ezra as the law of the rebuilt temple of Zion;" that the completion of the Pentateuch was later than this; that the Samaritans, hitherto knowing nothing of the Pentateuchal institutions, and at this time being at bitter feud with the Jews, yet "derived their Pentateuch from the Jews after Ezra's reforms, *i. e.*, after 444 B. C.;" and yet that in 432 B. C. this "foundation of a community of the Law in the Samaritan country, among the mixed population whom the Judean leaders did not venture to receive into fellowship," "a community bitterly hostile to the Jews, and yet constituted in obedience to Ezra's Pentateuch," was an accomplished fact. The author is conscious that this "must appear a very remarkable exploit;" that among these people who did not accept the historical and prophetic books, and who, therefore, could not, like the Jews, be reasoned with by arguments drawn from those books, "the acceptance of the Pentateuch implied a tremendous breach of continuity;" especially since, sudden though it was, yet "having got the Pentateuch, they followed it with a fidelity as loyal and exact as the Jews themselves, save in the one matter of the change of the sanctuary." He is correct in this. On the basis adopted by him, the exploit is so remarkable as to be impossible; the breach of continuity is too tremendous to be credible. We must look for some more satisfactory account of the matter.

The statement that the breach between the Jews and the Samaritans was made absolute by "the expulsion from Jerusalem in 432 B. C. of a man of high priestly family who had married a daughter

of Sanballat' is correct, save in two particulars: the date should be in or after 432 B. C., and this daughter of Sanballat may have been of a younger generation; there is just the same reason for describing her as a woman of the Sanballat family that there is for calling her husband a man of high priestly family. The statement that probably "this priest is the Manasseh of Josephus, who carried the Pentateuch to Shechem, and for whom the temple of Gerizim was built" is correct, save that the alleged fact that Manasseh took the Pentateuch to Shechem is not drawn from the Bible or from Josephus, but is made to measure, to fill an otherwise vacant place in the theory. But it does not follow that Josephus testifies falsely when he says that the Manasseh in question was the brother of Jaddua the high priest, and that the Gerizim temple was built in the time of Alexander the Great, though it must be admitted that the Sanballat whom Josephus makes to have been associated with Manasseh in the time of Alexander the Great cannot have been the Sauballat of Nehemiah.

It is not unlikely that the head of the Sanballat family may have had successors of the same name. The expulsion of the priest who married into that family occurred, according to Neh. xiii. 28, after 432 B. C. and before the death of Nehemiah. The date of Nehemiah's death is unknown, but as the accounts make the impression that he was a very young man in 445 B. C., he would not be extraordinarily long-lived if he lived long enough to witness the marriage of a youth who was still living, in a vigorous old age, when Alexander captured Tyre, B. C. 332.

This correction of the data of the article in the BRITANNICA, while fatal to the general theory with which that article is connected, might yet help out that part of the theory directly used in the article, for it allows a century instead of a decade for the differentiation of the Samaritan religion. But even with this extension of time, the eager acceptance of the Pentateuch by the Samaritans cannot fairly be explained, if the Pentateuch is of post-exilic Jewish origin.

The Samaritan traditions are, of course, to the effect that the Pentateuch came down to them from ancient times, and while there is here a lack of proof, there is nothing unreasonable or contrary to any known fact in the supposition that the tradition is to this extent true. That "the Samaritan character is an independent development of the old Hebrew writing" is a fact, but that indicates nothing as to "the time when they first got the Pentateuch;" at most, it only points to the time when they and the Jews began to use different alphabets in writing the Pentateuch.

As to the text of the Samaritan version, the assertion that "the Samaritans had no opportunity of revising their text by Judæan copies" is, of course, gratuitous, though not important for any point now under consideration. "That from the first their text ran a separate course" is probable, and shows that this text has some independent value as a source of text criticism; but the assertion that "in Judæa also there were important variations between MSS. down to the time of the Septuagint and even later" stands on a different footing. See SEPTUAGINT. In fine, there is much in the relations between the Jewish text, the Samaritan text, and the Septuagint, which needs no other explanation than the following statement of fact excerpted from the article in the BRITANNICA: "Samaritans as well as Jews were carried to Egypt by Ptolemy Lagi; the rivalry of the two sects was continued in Alexandria (Jos. Ant. XII. i. 1), and Hellenized Samaritans wrote histories and epic poems in Greek with exactly the same patriotic mendacity which characterizes Jewish Hellenism." (W. J. B.)

SAMSON. As regards the name of this judge of Israel, the statement in the BRITANNICA that the Masoretic pronunciation *Shimshon* is more modern than that followed by the Septuagint, whence comes our "Samson," is not a well-settled fact, but only a conjecture.

As regards his history, attention to the comparative syntax of the closing verses of Jud. xv. and xvi. will throw light on these accounts. Jud. xv. 20 begins with *Waw* consecutive, and may easily be understood to mean that Samson judged Israel twenty years, beginning with the battle at Lehi, and as the sequel to that battle. The concluding statement of Jud. xvi. 31, on the other hand, is a circumstantial clause, retrospective in its effect: "he having judged Israel twenty years." With this agrees everything in the narratives concerning Samson. In chaps. xiv., xv. we have stories in regard to his wild youth, and in xvi. two stories in regard to the latter months of his life, while the twenty years during which he was judge of Israel come between the two.

That the twenty years were with him years of more serious purpose than those concerning which details are given, that in them he actually accomplished the deliverance for Israel which it had been promised he should accomplish, may fairly be inferred from a certain characteristic difference between the two parts of the narrative. In his youth, before he was judge, in the part of his career covered by xiv.-xv., the Philistines are represented as lords of Israel, coming up into the country at their pleasure; in his last months the narrative in xvi. represents them as keeping on their own side of the frontier, and making no attempts on Samson except as they can catch him across the border. The difference between the two situations is wide, and is doubtless to be regarded as due to the ability of Samson the judge. It was after these years of good service that he allowed himself to relapse into follies like those of his youth.

With this view of the case there is no reason for counting Jud. xv. 20, and xvi. 31, last cl., as mere "editorial notes which belong to the chronological scheme of the book of Judges;" it is at least equally appropriate to regard them as part of the narrative itself. There is no contradiction between these verses which call him judge and the rest of the narrative. The representing of him "as a popular hero of vast strength and sarcastic humor" is not inconsistent with his being also judge and "the deliverer of Israel." No one who calls to mind how mixed are the motives from which men usually act has a right to say that the narrative represents Samson as "inspired by no serious religious or patriotic purpose," and acting "only from personal motives of revenge;" if he was like other men, he is likely to have been under the influence of both sets of motives. Doubtless, however, the serious aspects of his character are less fully brought out than they would have been had the narrator given us fuller accounts of what he did as judge.

The most common traditional opinions make Samson a contemporary of Eli. The author of the article in the BRITANNICA is in accord with this when he says that the narrator "conceives of his life as a sort of prelude to the work of Saul (xiii. 5)." But this author rightly notices also that the affiliations of the narrative are decidedly with the times of Gideon, and that is equivalent to saying they are not with the times of Eli. We have seen that Samson is represented to have accomplished the deliverance promised through him, and this can hardly be reconciled with the idea of his living in the times of Eli. As he is said to have been judge of Israel, it is a somewhat violent device to limit his judgeship to some narrow locality, as those who defend the tra-

ditional view are obliged to do. On the whole it is more in accord with the evidence to regard the Philistine oppression, with which he was concerned, as that mentioned in Jud. x. 7, distinguishing it, on the one hand, from the earlier oppression of Jud. iii. 31 and x. 11, and, on the other, from the later oppressions of the times of Eli and Saul. See ISRAEL and SAMUEL. On this view the exploits of Samson, recorded in Jud. xiv.-xv., occurred while Jair the Gileadite was judge, a generation later than Gideon, and Samson's administration was followed by the eighteen years of oppression by the Ammonites.

As to the conjecture "that originally his Nazirite vow was conceived simply as a vow of revenge," it should be noticed that the Nazirite obligation, in Samson's case, is not said to have been of the nature of a vow taken by him, but of the nature of a command laid upon him. On the difference between the Nazirite for life and the Nazirite by vow, see VOWS and OATHS.

(W. J. N.)

SAMUEL. Doubtless the genealogies in 1 Chronicles make this eminent judge of Israel a Levite, not, as the *BRITANNICA* states, "because a post-exilic family of singers traced their stock from him," though that may have been the case, but simply because he was a Levite. The statement that in 1 Samuel "the story certainly implies that it was not by birth but only by his mother's vow that he was dedicated to the service of the sanctuary" needs modification. It may have been both by birth and by his mother's vow; the latter does not exclude the former, but rather presupposes it. His mother would not have made the vow unless she knew that he was by birth eligible to the service. On the supposition that only Levites were then eligible, the fact of her making the vow shows that the family was Levitical. That such was the case is borne out by all the evidence there is. There is nothing in the recorded history to prove that "at that early date the priesthood was by no means confined to the Levites," but much to prove the contrary.

The English Palestinian survey maps are doubtless correct in locating Arimathaca, that is the Ramathaim-Zophim of 1 Sam. i. 1, in the Ephraimite country, near Bethlehem-Judah. The author of the article on SAMUEL in the *ENCYCLOPEDIA BRITANNICA* is also correct in assuming that the Ramah of Samuel is the same with Ramathaim. It follows that the district of Zuph (the Zophim of the name Ramathaim-Zophim) was not of "the tribe of Ephraim," but of Judah, south of Benjamin, where it is correctly located, 1 Sam. ix. 5; x. 2, the location of the grave of Rachel being stated here as in Gen. xxxv. 19, 20, not "on the frontier between Ephraim and Benjamin," but south of Benjamin, near Bethlehem-Ephrathah. The altering of the Hebrew text of 1 Sam. i. 1, either by dropping the word Ephraimite, or by changing it to Ephraimite, is needless and against the facts. There is no contradiction in saying that Elkanah was at once a Levite, an Ephraimite, and of the mountain country of Ephraim; and the account says that he was all three.

In regard to the work of Samuel as judge and prophet, see the following article and also ISRAEL and PROPHETS in this Encyclopædia.

SAMUEL, BOOKS OF. The statement made in the *ENCYCLOPEDIA BRITANNICA* that these books have been "freely handled by copyists down to a comparatively late date, as the variations between the Hebrew text and the Septuagint show," ought not to be accepted without verification, and it is a statement which it would be difficult really to verify. See SEPTUAGINT.

That the two books of Samuel anciently were

and still are, for certain purposes, counted as one book, and that the same thing is true of the two books of Kings, is indisputable; that for other purposes they are now counted as two books each, and have been so counted as far back as we can find information on the subject, is equally indisputable, though this fact is often ignored. There is no ground for arguing as if at some time the books of Samuel have been "divided from" those of Kings, or 1 Samuel divided from 2 Samuel.

That the books of Kings, though they continue the history from about the point where the books of Samuel leave it, are yet written from a different point of view, and constitute an entirely separate piece of composition, has been briefly shown in the article on KINGS. The literary affiliation that exists between the earlier chapters of 1 Kings and chapters ix.-xx. of 2 Samuel does not disprove this, for it may be accounted for by the fact that the author of Kings used materials from the same sources whence came these chapters of Samuel.

The books of Judges, Ruth, and Samuel, as they stand in the versions (in regard to the place of Ruth, see article on RUTH), form a continuous and unique work, whose analysis, within certain limits, is marked on the face of its contents. First come certain prefatory statements, of a rather miscellaneous character, Jud. i.-ii. 5. Second, we have a compacted history, Jud. ii. 6-xiii. 1, which begins by repeating several of the last verses of Joshua, then states the generic process of the history of the times of the judges, and then narrates the events up to the last year of Eli, the account which is begun in Jud. xiii. 1, being directly continued in 1 Sam. iv. 1b. *seq.* (For the chronology, see ISRAEL.) This section has full chronological data. Third, we have five stories, constructed on a common model, each complete in itself, and differing in literary character from the narratives of public history that precede and follow: the story of Samson, Jud. xiii. 2-xvi., the story of the capture of Laish by the Danites, xvii.-xviii., the story of the civil war with Benjamin, xix.-xxi., the story of Ruth, and the story of the birth and training of Samuel, 1 Sam. i.-iv. 1a. The five follow one another with no comment or interval. There is a sixth story of the same sort, the story of Saul and the asses, 1 Sam. ix.-x. 16. Each of the six begins with a certain formula, introducing the characters of the story, and this formula occurs nowhere else in this part of the Bible. Each of the six stories is complete in itself. Any one of them, or any number of them, or all of them might be removed without leaving any gap in the main narrative. This has actually been done with the story of Ruth, and might equally well be done with the others. The incidents recorded in the stories are omitted in the connected narratives that precede and follow. The stories themselves have chronological numbers only occasionally. The first three are grouped with the others at the cost of being removed from their proper chronological connection. Fourth, beginning with 1 Sam. iv. 1b, and omitting the story, ix.-x. 16, we have a series of narratives of the public history from the fortieth year of Eli (Jud. xiii. 1; 1 Sam. iv. 18), through the reign of David. For the reign of David these narratives are dated, 2 Sam. v. 4-5; ii. 10-11; xiii. 23, 38; xiv. 28; xv. 7; for the earlier period, the dates are incomplete, 1 Sam. vii. 2; xiii. 1; xxvii. 7. The narratives are arranged mainly in the order in which the events occurred, but, according to 1 Chron. xiii. 5, the events narrated in 2 Sam. vi.-vii. belong after those narrated in viii. and x.-xii., and although this testimony has commonly been ignored by scholars of all schools, we may yet, by accepting it, find a continuity in the history of David such as will otherwise be sought in vain. Further, viii. is a sequel to v., summarizing the events of David's

reign, up to the completion of his conquests, and x. -xii. is a different sequel to v., detailing certain specific events. And fifth, we have the six appendices found in 2 Sam. xxi.-xxiv.

As to the order in which these parts were written, it is natural to suppose that the prefatory sections in Jud. i., ii. 5, and the appendices, 2 Sam. xxi.-xxiv., were added after the rest of the book had been put together, though some parts of them may have been actually written earlier. There is no ground for the statement that "the appendix, 2 Sam. xxi.-xxiv., must have been added after the books of Kings had been separated from the context to which 1 Kings i., ii. originally belonged," for there is no proof that these books ever existed otherwise than separate, and consequently no proof that any separation was ever made. A perfectly natural account of the phenomena is that the appendices were added when the earlier historical series was collected, and that later, the compiler of Kings, when he entered upon his work, used an early narrative similar to those used by the compiler of Samuel. Two of the appendices, namely, 2 Sam. xxii. and xxiii. 1-7, are explicitly attributed to David, in the context, and there is no reason for minimizing this testimony into a mere expression of a late opinion on the subject.

It is probable that the narratives of David's reign and the continuous history in Jud. ii. 6-xiii. 1, with perhaps the continuation of that history in 1 Sam. iv. 1b-vii., the sections where the chronological data are full, were written later than the stories, and later than the narratives of the times of Samuel and Saul, where such data are lacking.

The account of the books of Samuel in the *ENCYCLOPEDIA BRITANNICA* is largely made up of an attempt to discredit those sections of the books which cite from the Pentateuch, or allude to it; it represents these to be the work of a later narrator or redactor, and to be inconsistent with what are assumed to be the older and more trustworthy parts of the books. Largely, though not entirely, these alleged later sections correspond with the parts of the book that seem to be latest, by the analysis just given. But there is nothing to indicate that these later parts are very much later than the other parts, and there are no contradictions between them.

That "these two books, together with Judges, are made up of a series of extracts and abstracts from various sources," is partly true, as any one can see by reading the books with this question in mind. That they "have been worked over from time to time by successive editors" is a different proposition, and one which, in the nature of things, is incapable of proof. Given the original documents and a single editor, and the phenomena are as well accounted for as by any hypothesis of additional editors.

That "the main redaction of Judges and Kings has plainly been made under the influence of the ideas of the book of Deuteronomy," and that "the Deuteronomistic hand" is clearly recognizable in the books of Samuel is true, and it is therefore clear that Deuteronomy antedates all these books; but we need not infer the late date of Judges and Samuel in order to account for these facts; they are better accounted for by inferring the early date of Deuteronomy.

Since the song of Hannah, 1 Sam. ii. 1-10, and the prophecy, ii. 27-36, are incorporated into the story that occupies i.-iv. 1a, and not merely into the whole book of Samuel, the supposition that they are later insertions by some redactor of the book is less likely than that they are original materials, used by the writer of the story.

On the view that the narratives of the times of Saul were written earlier than those of the times of David and of the earlier judges, the most natural

explanation of 1 Sam. xiii. 1, is not that "one of the numbers has been left blank and the other has been falsely filled up by a mere error of the text," but that we have here an earlier use of the phrase "in his reigning" than that which prevails in the later writings. Later, the phrase is restricted to the meaning "when he began to reign," but here, as the King James' translators correctly held, it means that Saul was one year old in his new position as king, and that, at the beginning of his second year, he made the arrangements described in the next verse. The statement that "the similar note in 2 Sam. ii. 10, seems also to have been filled up at random; it contradicts and disturbs the context," is not well considered. There is here no contradiction with the context, but simply a presentation of the fact that although it was seven and a half years after Saul's death before David became king of all Israel, only two years of that time were occupied by the reign of Ishbosheth.

The assertion that "chapter vii. with . . . its account of a victory at Ebenezer . . . which delivered Israel from the Philistines all the days of Samuel, is inconsistent with the position of the Philistine power at the accession of Saul" is based on a careless idea, very commonly held, of the reign of Saul. This particular careless idea will be banished from the mind of any one who will take the trouble to observe that, if this account is in any sense historical, 1 Sam. xiii. 1, 2, must be regarded as a paragraph by itself in the history, the event mentioned in it being separated by an interval of a good many years from the events narrated in the following verses. In proof of this, notice that the accounts certainly make the impression that Saul, at his accession, was so young as to be immature; this being the case, the crown prince, Jonathan, was a little child when the arrangements of xiii. 2, were made. Saul placed one-third of his guard in charge of his home and his young heir, and with the other two-thirds established a military camp near by; but when the events of verse 3 take place Jonathan has become a warrior grown. It follows that the first recorded trace of Philistine invasion in the times of Saul was not at the beginning of his reign, but many years afterward. That Samuel's administration left the country with large resources, and free to concentrate them, appears from the numbers who gathered at Saul's first call for troops, 1 Sam. xi. 8.

The narrowness of the circuit of the four cities, 1 Sam. vii. 16, 17 (the circuit was not narrow if the Mizpah in it was the Mizpah east of Jordan), does not imply that Samuel's position was correspondingly narrow; it shows rather that his going from one city to another may have had some other object than that of bringing his court locally near to those who had business with it; the fact remains that he is said to have been judge of Israel, and not of any one region merely.

The great instance of alleged inconsistency in the statements of David and Goliath. In regard to this see article DAVID. The other alleged unhistorical elements in these books are no more difficult to deal with than those which have been thus considered.

The article in the *ENCYCLOPEDIA BRITANNICA* dates the books of Judges and Samuel, in their present shape, as later than the reform of King Josiah. Probably a majority opinion of living scholars would assign them to a date two or three centuries earlier than this, but later than the division of the kingdom under Rehoboam. The Jewish traditions say that the prophet Samuel wrote these books, and Gad and Nathan completed them. If this be understood to mean that Samuel personally wrote Judges and Ruth and the parts of Samuel that record events preceding his death, it is subject to grave objections. But if it be understood to mean that Samuel gave

the literary impulse that led to the production of the books, himself writing some of the stories and narratives; and that all the parts were written and collected before the death of Nathan, and by these three prophets, or under their influence, it is an opinion that cannot be successfully overthrown by evidence.

Decidedly in favor of this opinion is the testimony of 1 Chronicles, both in its use of the books of Samuel, 1 Chron. x.-xxi., and in its description of the sources of the history, xxix. 29. Note that for the history of David, Nathan is associated with Samuel and Gad, while for the history of Solomon, 2 Chron. ix. 29, he is associated with two later prophets. The likeness between parts of Samuel and the first chapter of Kings naturally connects itself with these two references to Nathan.

The principal argument brought against this view is the alleged existence in these books of allusions to events later than the reign of Solomon, but if any one will carefully examine the instances adduced, he will find them insufficient. The very strongest group of these instances is made up of the places where Judah is mentioned as distinct from Israel; but there is not one of these places where it is necessary to understand that the reference is to the divided kingdom, after the death of Solomon, and in most of the places it would be unnatural to understand this. The most extreme instance is in 1 Sam. xxvii. 6: "Ziklag pertaineth unto the kings of Judah unto this day," and this might apply to David and Solomon as well as to the later kings. They held Ziklag by a peculiar title, not in virtue of their being kings of all Israel but in virtue of their being kings of Judah. There are few instances or none where it would be necessary to resort to the hypothesis of a gloss in order to defend the view that these books were completed within the lifetime of Nathan. On the contrary, the absence of elements clearly later than Nathan's time is sufficiently marked to be a reason of positive weight in favor of this theory of the early origin of this group of books.

Many assertions to the contrary notwithstanding, the Biblical accounts certainly represent the times of Samuel, Gad, and Nathan to have been times of literary activity and times of historical research, that is to say times in which such a work as this might very naturally be produced; 1 Sam. x. 25; xxi. 13; ii. 1-10; 2 Sam. xi. 14, 15; xxii.; xxiii. 1-7; 1 Chron. xxvii. 24; xxiii. 27; 2 Chron. ii. 11, etc., and 2 Sam. xi. 20, 21; cf. Jud. ix. 53; 2 Sam. vii. 6, 8-11; viii. 16, 17; 1 Sam. ii. 27, 28; iv. 8; xii. 6-11, and many other passages.

Literature. For general use, the best English Commentary on Samuel is perhaps that in the *Cambridge Bible for Schools* series. That by Dr. R. Payne Smith, dean of Canterbury, in the *Pulpit Commentary*, is one of the best works in that series. The two volumes by Dr. W. G. Blaikie, in the *Expositor's Bible* (New York, 1888), are attracting attention. The work of Prof. August Klostermann on Samuel and Kings, in *Kurtzgefasster Kommentar*, edited by Strack and Zöckler (Nördlingen, 1887), is admirable. The books of Samuel are treated in the inductive Bible studies in the *Old Testament Student*, Sept. and Oct. 1887. Certain topics in the books are handled in Dr. R. S. Green's *Jonathan and Absalom* (Phila. 1887). (W. J. B.)

SAN ANTONIO, the county seat of Bexar co., Texas, is on the San Antonio River, 216 miles W. from Houston, on the Southern Pacific, and two other railroads. It has a county court-house, U. S. government building, opera-house, 6 hotels, 5 national banks, 6 other banks, 4 daily and 4 weekly newspapers, a large cathedral, 20 churches, and several schools. The city is lighted with gas, and has a large park. Its property is valued at \$16,300,000. It dates from 1673, and when a mission was founded on the opposite side of the river. The chapel afterwards became Fort Alamo, and was the scene of a massacre in the Texan war of independence. (See

ALAMO.) The city retains some picturesque features indicating its Spanish origin, but is rapidly assuming a modern American appearance. The present inhabitants are chiefly of American, German, and Spanish origin. Its population in 1880 was 20,550, but it has greatly increased.

SANDERSON, JOHN (1783-1844), author, was born at Carlisle, Pa., and studied law in Philadelphia, but was chiefly engaged in teaching. He warmly defended the study of the ancient classics. Of the *Lives of the Signers of the Declaration of Independence* (9 vols.) he wrote two volumes, the rest being prepared by his brother, J. M. Sanderson. A later edition, revised by Robert T. Conrad, was issued in 1865, and a centennial edition in 1876. Sanderson in 1835 was obliged to go Europe for his health, and wrote home some pleasant papers, which were gathered as *Sketches of Paris* (1838). Similar sketches of England were contributed to the *Knickerbocker Magazine*. After his return he was professor of Greek and Latin in the Philadelphia High School till his death, April 5, 1844.

SANDUSKY, a city and county seat of Erie co., Ohio, is on the south shore of Sandusky Bay 5 miles from Lake Erie, and 56 miles W. of Cleveland. It is in 41° 27' N. lat., and 82° 45' W. long. It is the Lake terminus of the Baltimore and Ohio, the Indiana, Bloomington, and Western, and the Lake Erie and Western Railroads, and is on the Lake Shore and Michigan Southern Railroad. The harbor is the best on Lake Erie, and admits to wharf the largest vessels used in lake commerce. In the season there are regular daily lines of steamers to Detroit and other lake ports. The average entries for the season, in recent years, have been coastwise, 1800; foreign, 375; clearances, coastwise, 1825; foreign, 300; tonnage, 380,000. The site of the city rises gradually from the shore, giving a beautiful view of the bay. It is on a limestone bed, which furnishes good material for building. It has a court-house, custom-house, 3 national banks, 22 churches, a public library, a high school, and 5 other school buildings, 3 daily and 6 weekly newspapers, one of these being German. It has several machine shops, car-works, manufactures of cutlery, hardware, wheels and wood-work. In the last it exceeds any other American city. It is the largest fresh-water fish market in the world, shipping 12,000 tons of fish annually. There is also large trade in lime, limestone, lumber, salt, coal, ice, grain, and fruits. About 1,200,000 gallons of native wine are shipped here annually. Erie county produces large crops of wheat, Indian corn, potatoes, and fruits. There are several noted summer resorts in the vicinity of Sandusky, such as Put-in-Bay, Lakeside, and Kelley's Island, and the city itself is so used. The population in 1880 was 15,838.

SAN FRANCISCO, the chief city of California, is on the end of a peninsula between the Pacific Ocean and the Bay of San Francisco. It is the chief seaport of the Pacific coast, having about 50 steamers running on regular lines to China, Japan, Honolulu, Australia, and South America. There are also numerous steamboats using the bay and its affluents. The public buildings comprise the city hall, commenced in 1871, and costing over \$4,000,000, the U. S. Mint, custom-house and other government buildings, the merchants' exchange, stock exchange, which cost \$900,000, house of correction, Masonic temple, and several theatres and opera houses. There are many stores and warehouses solidly built, and six or more stories in height. The industrial works comprise sugar refineries, woolen mills, flour mills, glass works, canneries, wire works, iron-ship works, and large establishments for making heavy machinery. There are also man-

ufactories of clothing, shirts, shoes, and jewelry.

The city has an area of 42 square miles. The gas-works, which belong to private companies, are valued at \$6,625,000, and have a capacity for 4,000,000 cubic feet daily. The fire department comprises 15 engines, 1 fire boat, 8 hose carts, 5 hook and ladder trucks, and 325 men. The city has, however, suffered severely from fire. The fire of May 4, 1851, when the buildings of the city were chiefly of wood, caused a loss of several millions of dollars. On Aug. 21, 1886, there was a conflagration, the loss in which was estimated at \$1,000,000. The street railroads have about 35 miles used by horse cars and an almost equal amount on which cable cars are used. For education the city appropriates nearly \$900,000 annually. The total revenue is about \$3,750,000, and the yearly expenditure \$3,555,000. The city debt is \$1,457,000, and the rate of taxation 1.57 per cent.

The population in 1880 was 233,859, including 20,000 Chinese. It is now estimated to exceed 320,000, and the Chinese number about 25,000. The latter have six large Joss houses and many smaller ones. Besides the large and enterprising journals and periodicals in English, there are daily and weekly papers in French, Italian, German, Spanish, and Chinese.

SANITARY COMMISSION, the UNITED STATES, was created June 9, 1861, by an order of the secretary of war; its board, appointed by that officer and the United States Medical Bureau, consisted of H. W. Bellows, D.D., Professors A. D. Bache and Wolcott Gibbs, Drs. Jeffries Wyman, W. H. Van Buren, S. G. Howe, and R. C. Wood, U. S. A., with two army officers, G. W. Cullum and A. E. Shiras. This organization had been preceded by several of local and unofficial character, called forth by the intense interest felt by the people of the loyal States in the welfare of those who had gone forth to represent them in the field and to fight for the Union and human freedom. April 15, 1861, President Lincoln issued his call for 75,000 men; on that very day societies were formed by the women of Bridgeport, Conn., and Charlestown, Mass., to furnish aid and relief to the volunteer troops. Within a few days similar action was taken at Lowell, Mass., and Cleveland, O. The Women's Central Relief Associations of New York, organized at the Cooper Union, April 29, at a meeting called by ninety-one prominent ladies of the city, became the chief source whence the Sanitary Commission sprang. It presently sent to Washington a committee, consisting of Drs. Bellows, Van Buren, Harsen, and Harris, to consult with the War Department and the Medical Bureau, and secure, if possible, the appointment of a commission such as had rendered eminent services to the British army in the Crimean war. The government, fearful of lay intermeddling and collision with its officers, refused to grant similar powers without the consent of the Medical Bureau, which could not be obtained, and the commission when created had but a semi-official character, no authority, and the privileges merely of visiting the troops, consulting with the Bureau, and recommending sanitary regulations and reforms to the War Department. Not the active support of the government and its officers, but the warm sympathy of the people at home, enabled it to grow rapidly from feeble infancy to vigorous life, and to render those noble services which made its name blessed throughout the land.

It had many difficulties to contend with and overcome. The natural jealousy and suspicion of the surgeons and other officers proved beneficial, as affording the stimulus of criticism, and holding the employes of the Commission to a strict account. The lack of any general appreciation of the dangers of camp diseases, and the inability of the public mind to enter into the main object of the Commission,

which was prevention rather than cure, were embarrassing. The first volunteers were very young, more than half under twenty-four, and many mere boys. Their parents, sisters, and friends had a vague but strong feeling that they ought to be supplied with comforts in the way of food and clothing, beyond what the government provided; and this, with ministrations to the sick and wounded, was popularly supposed, throughout the war, to be the main work of the Commission; but its leaders held far wider views. Few things in modern history are more creditable than their management of the vast interests doubtfully and grudgingly committed to their care, combining as it does statesmanlike foresight, careful prudence, and rigid integrity, with humane and patriotic zeal. Its officers deserve an honorable place in American remembrance. Dr. H. W. Bellows, of New York, was president and the soul of the organization; A. D. Bache, LL.D., of Washington, vice-president; G. T. Strong, of New York, treasurer; Drs. Van Buren, Agnew, and Gibbs the medical committee. The general secretaryship at Washington was held most efficiently by F. L. Olmsted, 1861-3, Dr. J. F. Jenkins, 1863-5, and J. S. Blatchford, 1865. Prof. J. S. Newberry, as Western secretary at Louisville, was equally energetic; these gentlemen, in charge of the two great depots of supplies and distribution, ably discharged a heavy responsibility. To the original board were soon added, besides those just named, Dr. Elisha Harris, Bishop T. M. Clark, of Rhode Island, Horace Binney, of Philadelphia, and several others. The board held twenty-three lengthened sessions at Washington, and during the intervals a standing committee, composed of Drs. Bellows, Van Buren, Gibbs, and Agnew, with Mr. Strong, and afterward C. J. Stillé, met almost every day in New York. None of these officers received pay, except those who gave their whole time to the work; but it was soon found better and cheaper to employ salaried persons in the field, thus establishing a system of accountability, discipline, and promotion; volunteer help was then accepted only as supplemental in special cases. Method and subordination were necessary to success, and won the tardy respect of the medical and military officers of the government.

The finances of the Commission were for over a year very limited, money coming in much less freely than goods. June 21, 1861, aid was asked from the people and from the life insurance companies. By Sept. 1 only \$13,630 had been received, and by Mar. 28, 1862, but \$53,720. Under these discouraging circumstances, only the faith and zeal of its leaders prevented its dissolution. By Sept. 10, 1862, the amount had reached \$158,501, chiefly from New York, Philadelphia, and Boston, and the embarrassments were great. But within the next twenty-three days California had sent two contributions of \$100,000 each. This was the beginning of a new era; the services of the Commission began to be appreciated, and money to flow in more freely. Considerable sums came from Buenos Ayres, the Sandwich Islands, and branches in London and Paris. The famous "Sanitary Fairs," held early in 1864, reached the popular purse; that of New York yielded \$1,184,487; Philadelphia, \$1,035,308; Brooklyn, \$305,513, while smaller amounts came from Albany, Boston, and other cities. Of all the contributions to Jan. 1, 1866, that of California was the greatest, \$1,233,977; New York followed with \$229,328; Massachusetts with nearly \$122,000; Nevada with \$107,642, and Oregon with \$79,406. The total of cash receipts was \$4,924,480; and at least \$2,000,000 more was raised and expended by the branches. The estimated value of goods was \$15,000,000.

These gifts—provisions, drinkables, dry goods of all sorts—came from every part of the land; from

cities, villages, and farms, often bearing the marks of loving self-denial. The cost of their transportation was diminished full two-thirds by the generosity of railroad and express companies, whose services (as also those of the telegraph lines) were in most cases gratuitous. Depots of supplies were established Sept. 5, 1861, at Boston, New York, Philadelphia, Washington, Cincinnati, and Wheeling; central aid associations had previously been formed also at Columbus, Cleveland, Chicago, and elsewhere in the West. The boxes sent to these places were opened, their contents sorted, recorded, and sent where they were needed. The Commission received nothing meant for any particular person or place, and recognized no distinctions of State or regiment, but aimed to minister to all soldiers of the Union alike. The government was unable to provide adequately for the sick and wounded; the efforts of affection or charity in the North, whether individual or local, to send help to the camps and battle-fields were perforce in large measure confused and futile; the Commission, with its carefully devised system, its admirable administration, and its army of earnest and disciplined employes, stepped in as an intermediary, and distributed the loving bounty of those at home to their defenders throughout the South.

The relief bestowed was of two classes, general and special. An inspector and staff of agents, with four-horse wagons or steamboats loaded with supplies, were usually attached to each army corps and to each expeditionary force. The inspector (always a physician) visited the hospitals, was in frequent conference with the surgeons, and on their demand furnished from his stores food, clothing, wines, medicines, etc. So far as was possible, battles were anticipated and provided for; at 600 out of 700 during the war, the agents and stores of the Commission were present. After Antietam, *e. g.*, it cared for near 10,000 wounded during four days, in which no government supplies were accessible. An auxiliary relief corps, some 150 members, was organized in May, 1864, to minister to the wounded left in hospitals when the army continued its march. Feeding-stations on the route of the ambulances was part of its work. Among those who fell in this dangerous service were the wife of Gen. Barlow and Prof. Hadley, of Union Theological Seminary in New York.

The Special Relief Service was intended mainly for the sick of new regiments, and for soldiers discharged or dismissed from hospitals; the latter were aided on their way home, protected from sharpers and from their own weaknesses, and their arrears of pay collected for them. Forty homes and lodges were established and sustained throughout the land, from Boston to Brownsville, Texas. Over one million nights' lodgings, and nearly five million meals, were thus supplied, and \$2,500,000 of pay obtained. A pension bureau and war claim agency was founded, which after the war took charge of some 57,000 claims, and collected \$7,500,000 gratuitously. A convalescent camp near Alexandria, Va., long directed by Miss Bradley, rendered various services to very many. The special relief service was organized and controlled by Rev. F. N. Knapp.

But these labors, however useful to the soldiers, and however effective with the popular mind, were not the only work of the Commission, nor, in the view of its leaders, the most important part thereof. They never lost sight of the ideas conveyed by their title, "Sanitary." Had they loudly proclaimed the scientific and far-reaching nature of their views, and confined themselves to the effort to prevent rather than to assuage suffering, they would have lacked popular sympathy and support. Brain bore as large a part in their work as heart and hand. Nothing that they did received more praise than

the *Hospital Directory*, which aimed to keep and follow up the record of the sick or wounded. A central office at Washington was opened Nov. 27, 1862, and branches followed at Philadelphia, Louisville, and New York. Agents took the names of the wounded after every battle, and 233 general hospitals sent frequent reports; thus a list of over 600,000 was kept, with the latest facts known as to each. The worst horror of war to those at home was the frequent uncertainty as to the fate of relatives or friends; in such cases inquiries after the missing were prosecuted, and the facts learned in seven out of every ten cases. The archives of the Commission, preserved in the Astor Library, include a large row of folios of this *Directory*.

The *Bureau of Vital Statistics*, inaugurated by Secretary Olmsted, and carried on by Dr. B. A. Gould, did work of great scientific value and repute, embodying inspections of some 870 regiments, and tabulating statistics concerning "the effects of applied or neglected hygiene, of diet, of long marching and heavy equipment, of tent and fixed hospitals; the mortality of young recruits; the influence of climate, drill, nationality, of previous occupations, or state of education upon soldiers; the height, weight, strength, and force of the enlisted men," and other matters bearing upon life insurance, anthropology, etc. This the president of the Commission considered "one of the most creditable and faithful portions" of its work. Mr. Olmsted's report of the statistics of the battle of Bull Run, in the beginning of these collections, was "the first scientific attempt to generalize the causes of our disaster."

In ways more immediately affecting the physical welfare of the soldiers, the Commission by no means confined itself to the supply of food and clothing. A corps of sixty well-known medical men was organized under Dr. H. G. Clark, of Boston, to visit and inspect the general hospitals throughout the land, and report to the medical committee. These reports by May, 1863, covered 2500 folio pages, and on their basis suggestions were made to the surgeon-general for improvements in the hospital system, which thus reached a degree of excellence nowhere attained before, and unhappily not kept up in the United States since the war. The Medical Bureau also was closely watched from an early period, with a view of weeding out ignorance and incompetency. In this task much jealousy and opposition was aroused, and the existence of the Commission was for a time endangered; but a reform was at length accomplished, disorders and deficiencies in the main removed, and a system of promotion for services and merit substituted for that under the old rule by mere seniority.

The inventions of the Commission were of great benefit in assuaging suffering and saving life. The pavilion hospitals, built from its models, and intended to minimize the dangers of contagion and pestilence, were widely adopted. Its hospital cars and steamboats aimed to lessen the horrors attending the transportation of the sick and wounded by land and water with merely the ordinary government facilities. After the capture of Fort Donelson several States attempted to transport their own men, and yielded this service reluctantly to the Commission, whose organization was more complete and its facilities greater. Its steamers, provided with surgeons, nurses, and all necessaries, carried multitudes of sick and wounded men from the posts adjacent to camp or battle-field to the nearest hospitals. The hospital car, devised by Dr. E. Harris, of New York, was hung on gutta-percha springs to prevent jolting, and turned the stretchers on which the wounded were borne into hanging beds; supplied with comforts and attendance it did much to diminish for the wounded the torments of travel by the common modes of conveyance.

In fighting against scurvy, which attacked the armies of the Tennessee and the Cumberland in 1863, the Commission found a congenial field for its beneficent energies. An appeal to the farmers of the Northwest brought within a month 15,000 bushels of vegetables, when the government had been able to procure none. Hospital gardens were soon established at Murfreesboro, Nashville, Chattanooga, and Knoxville, Tenn., and at Newberne, N. C.; these proved of great value as producing a supply near the points where it was needed. Grant's forces at Vicksburg received vast quantities of supplies from Louisville by the zeal of Drs. Newberry and Warriner, and the health of the troops was largely improved thereby. After the fall of Vicksburg various branches of the Commission in the Northwest were active in sending boat-loads of stores. The hospitals along the Mississippi were supplied from Cairo by the steamer Dunleith. While the army was blockaded at Chattanooga, the Confederates took seventeen wagons of the Sanitary train in the Sequatchie Valley; but seven succeeded in reaching their destination, and the loads of these, and of three which arrived later, furnished the chief supplies of the hospitals for some time. A depot was established at Stevenson, Tenn., and a feeding-station on the route of the ambulances half-way between that point and Chattanooga. During the winter of 1863-4 the ordinary food of the troops brought on attacks of scurvy and chronic diarrhoea, which the Commission combated by means of its gardens and of contributions from the North. In January, 1864, the depot at Nashville sent out 3423 bushels of potatoes and 157 of onions, 8742 gallons of sauer-kraut and 1969 of pickles, with 13,662 lbs. of dried fruit, and other articles. The dissemination of these anti-scorbutics did much to diminish illness and keep our forces up to their work. The vegetables distributed in seven months of 1864 reached an estimated value of over \$66,000. Burnside's men at Knoxville were likewise cared for. Sherman's march to the sea was anticipated with 3000 barrels of vegetables and quantities of condensed milk, stimulants, beef, bandages, etc., and followed by 24 wagon-loads of stores. The 300 temporary hospitals along the route were all visited by agents of the Commission, and 17,000 meals were given at feeding stations in the rear.

This sanitary work in the Western armies received much more favor and aid from the military officers, high and low, than did the corresponding labors in the East. The army of the Potomac was better supplied, but the help of the Commission was welcome in frequent emergencies. After Fredericksburg a relief station, opened at Acquia Creek, cared for 600 men the first night. After Chancellorsville both the regular and the sanitary supplies were intercepted. Immense preparations were made for the battle of Gettysburg, and great services rendered. Competent agents, stationed at convenient points in Maryland and Pennsylvania, were in constant communication with those who accompanied the army on its march, and whose wagons were kept supplied from Washington; during the battle these were filled and returned from Fredericksburg, and much help given to the field hospitals. Two of the leading agents were caught by the enemy's cavalry, taken to Libby Prison, and there confined for some months: the Confederates rarely spared the Commission, though their wounded prisoners were cared for like Union soldiers. In the long list of articles distributed during ten days after the battle, some of the items are 11,000 lbs. of poultry and mutton, 6430 lbs. of butter, 20,000 lbs. of ice, 12,900 loaves, 8500 dozen eggs, 12,500 lbs. condensed milk, 3800 lbs. beef-soup, 7000 lbs. farinaceous food, 6800 lbs. white sugar, over 7500 drawers, over 10,000 shirts, nearly 5000 pairs socks, 10,000 towels and napkins, 7000

tin basins and cups, 2300 sponges, 1500 combs, 250 lbs. castile soap, 300 yards oil silk, and 3500 fans. In this humane activity nothing seems to have been overlooked, every need and comfort anticipated.

In the battles of the Wilderness 200 relief agents were busy with the wounded, and 200 tons of stores conveyed by two steamboats, two barges, and 44 wagons. In two months \$515,000 were received and expended for the army in Virginia. Malaria was resisted on the lower coast, and the health of the troops before Charleston fortified. At Fort Wagner the troops saluted the Sanitary flag, in recognition of benefits derived from supplies of ice and anti-scorbutics. At Olustee, Fla., the government had made no adequate provision of medical supplies, and the Commission filled the gap. At Newberne and Beaufort all the agents except Dr. Page, the inspector, were attacked by yellow fever, but he and Dr. Hand, the medical director, battled successfully with the pestilence. Drs. Crane and Blake rendered great services at New Orleans, and distributed far and wide the supplies sent down the river by Dr. Newberry. Messrs. Ingraham and Root were visitors in the hospitals at Nashville, through which 100,000 men passed in six months.

The agents of the Commission were themselves exposed to the evils they sought to counteract or mitigate, to the direct or indirect perils of war, to contagion, hardship, exposure, and often to capture, wounds, or death on the field of battle. Their faithful humanity and patriotic devotion in ministering to the comfort, health, and life of the defenders of the nation shall not be forgotten. By their means thousands who might also have filled unknown graves were restored to home and friends, and multitudes enabled longer to serve their country in the field. In nothing does our Christian civilization contrast more happily with the brutality and indifference of former times than in its efforts to mitigate the horrors and assuage the sufferings of war; and of these noble endeavors none have been more illustrious than those of the United States Sanitary Commission.

Its voluminous archives are preserved in the Astor Library, New York. Many of its reports possess historical and scientific value. Its official *History* has been written (1866) by Dr. Charles J. Stillé, LL.D., afterwards provost of the University of Pennsylvania, and more briefly by its president, Dr. Bellows, in Johnson's *Cyclopaedia*. See also Katharine P. Wormley's *The Other Side of the War* (1888), and Gen. P. R. De Trobriand's *Four Years with the Army of the Potomac* (1888). For the work of its kindred association, The U. S. Christian Commission, see that title. (F. M. B.)

SANITARY SCIENCE is a knowledge of the laws for the preservation of health, and practical hygiene is the art of so applying those laws as will best attain that end. This art has been practised from time immemorial: the ancients worshipped at the shrine of the goddess Hygieia, the alchemists sought for the "elixir of life," Moses gave to the Jews a hygienic code, and Hippocrates, the father of medicine, summed up the knowledge of his day in the following six articles: "Air, aliment, exercise and rest, sleep and wakefulness, repletion and evacuation, the passions and affections of the mind." But in more modern times the study of physiology and pathology opened new fields of research, and as knowledge was gained of the functions of the various organs of the human economy, the scientific investigation of the laws for the preservation of health was made possible. In still later years chemistry and microscopy have greatly added to this knowledge, until now we have a more thorough understanding, not only of the laws which govern the life and health of the individual, but also of the invisible yet potent agencies which cause

pathological changes resulting in wide-spread disease and death.

Scientific investigation into the means for preserving health in the United States is of quite recent growth, although fragmentary laws for the prevention of the introduction from foreign ports of contagious and infectious diseases were early enacted by the colonies. The colony of Massachusetts Bay, in 1648, through the general court, passed quarantine laws "for the prevention of a disease [yellow fever] so fatal in its character as was then prevailing in the Barbadoes and other islands in the West Indies." The province of South Carolina in 1698 enacted a law that "All vessels are forbidden to pass to the east of Sullivan's Island one mile, without permission of the governor, under penalty of being fired on by the gunner and paying a fine. The pilot is required to ascertain from the captain, before passing that limit, if any contagious disorders are on board, under penalty of £50." Pennsylvania in 1699, Rhode Island in 1711, New Hampshire in 1714, and New York in 1755 enacted quarantine laws to prevent the foreign importation of disease. Similar laws were enacted by seaboard States or municipalities after the Union was formed, and stimulated by the great yellow fever epidemic of 1793-5 the question of governmental control of quarantine was largely discussed in the fourth Congress (1795). The precedent set by the Congress of that day has been followed (after similar discussions) ever since, viz: The civil and military officers of the government are only empowered to aid in the execution of the health and quarantine laws of the several States. (Sec. 4792, Revised Statutes.) The ravages of yellow fever in 1817, at New Orleans, led the city and State authorities to enact very stringent quarantine laws in that year, but the recurrence of the disease the year following resulted, because of their inadequacy, in a "repeal of the laws for the prevention of the introduction of pestilential, malignant, or infectious diseases," directed the sale of the lazaretto and all its property and invested the governor with authority to establish quarantine at his discretion. Time and again the quarantine laws were re-enacted and repealed, until 1855 the present law was established and the detention, fumigating, and cleansing of vessels required. Since 1884 the plan adopted for maritime sanitation has been greatly improved upon—machinery being substituted for manual labor—and a steam tug is now used for forcing sulphurous acid gas into every part of a vessel's hold; this is followed by sprinkling and cleansing the decks, etc., with a solution of bichloride of mercury through hose connected with the steam engine, so that the detention of vessels at New Orleans may now be expressed in hours instead of days. (See FUMIGATION.)

During the first half of the present century no united effort was made in this country to prevent the occurrence or spread of disease, although individuals here and there discussed the subject of "preventive medicine," and tried to obtain recognition of the great principle that "prevention" was more scientific than "curing" disease. The questionable efficacy of quarantine was being agitated abroad, and the action of the first International Sanitary Convention, held in Paris in 1850, where the chief feature of the convention was the abrogation of useless quarantine restrictions and inculcating municipal hygiene in their stead, had a great effect upon the thoughtful minds of this country. Delegates from France, England, Austria, Spain, the two Sicilies, the Roman States, Greece, Russia, Portugal, Sardinia, Tuscany, and Turkey were present at this convention, their interest in which led to subsequent international congresses. Sanitary reform had also begun in England. The ancient fallacies of quarantine (forty days' detention) were attacked,

and internal sanitary measures, recommending destruction of *fomites* and all sources of infection in town or country, and the sanitary inspection of habitations substituted. The result of these public discussions of the inadequacy of quarantine restrictions alone, and the beneficial effects of sanitary measures, led the American Medical Association (instituted in 1847) to appoint a committee to investigate the sanitary condition of large cities. About this same time (1850) the legislature of Massachusetts printed a *Report of a General Plan for the Promotion of Public and Personal Health*, which had been prepared by a committee appointed for that purpose. This report was prepared with great care by Samuel Shattuck, a layman, and was filled with details relating to sanitary measures necessary for the prevention of disease; it also recommended the establishment of a State Board of Health with powers to effect the reforms so fully set forth. That report is bearing fruit after many years, and foreshadowed much that is now accepted as hygienic truth. After the great yellow fever epidemic of 1853 the New Orleans Board of Health appointed a commission with special instructions:

1. To inquire into the origin and mode of transmission of the late epidemic of yellow fever.
2. To inquire into the subject of sewerage and common drains, their adaptability to the situation of our city and their influence on health.
3. To inquire into the subject of quarantine, its uses and applicability here, and its influence in protecting the city from epidemic and contagious maladies, and,
4. To make a thorough examination into the sanitary condition of the city, into all causes influencing it in present and previous years, and to suggest the requisite sanitary measures to remove or prevent them, and to the causes of yellow fever in ports and other localities having intercommunication with New Orleans."

Circulars were issued by the commission to all parts of the country where yellow fever occurs, and the committee sat as a "court of inquiry" for three months gathering information far and wide, and stating that "prevention of an epidemic was the basis of the work to be done." The conclusions arrived at by the commission were that a combination of terrene and meteorological conditions was absolutely essential for the development of an epidemic, (heat and moisture combined with filth,) that policing is the remedy, that "sanitary reform is the talisman" and "hygiene the science of life," and recommended a thorough sanitary survey of the city, including every house, lot, and back-yard; every cause of disease should be abated, vaccination looked after, and a record of inspection kept of every square in the city, and finally the commission prepared an ordinance for establishing a health department for New Orleans "with ample powers to effect the reform suggested."

The first "Quarantine (sanitary) Congress" in the United States was held in Philadelphia May 13, 1857, called together by the Board of Health of Philadelphia, for the purpose of establishing a uniform system of quarantine in the maritime cities. Its members were not confined to the medical profession; commercial and municipal departments were invited and no less than 26 different authorities from nine Atlantic States were represented by 73 delegates; a three days' session was held in which the question of making uniform the quarantine regulations of the several States was fully discussed and 23 propositions were laid down in regard to quarantine. A permanent organization was effected and the congress adjourned to meet in Baltimore, April 29, 1858. The name of the congress was changed to "The Quarantine and Sanitary Convention." Twelve States represented by 86 delegates were present at the second meeting. Two committees were appointed—one on "external hygiene or quarantine" and the other on the "sanitary arrange-

ment of cities." Third meeting of the convention was held in New York, April 27-30, 1859, at which the report of the committees appointed at the second meeting was discussed. The fourth meeting of the convention was held in Boston, June 14-16, 1860, at which sanitary science, "State medicine," quarantine and the management of epidemics, vaccination, vital registration, etc., were discussed, and cleanliness of cities declared to be more important than quarantines. The efficacy of steam as a purifier and preventive was here first suggested. The next meeting was appointed for May, 1861, at Cincinnati, but the civil war intervening caused it to be abandoned. In May, 1861, three associations of New York (the Woman's Central Association for the relief of the sick and wounded of the army, the Advisory Committee of the Board of Physicians and Surgeons of the hospital of New York, and the New York Medical Association for furnishing hospital supplies in aid of the army) proposed to the secretary of war the "Sanitary Commission" with the "object of bringing to bear upon the health, comfort and morale of our troops the fullest and ripest teachings of sanitary science," to inquire into the subject of diet, cooking, cooks, tents, company grounds, transports, and everything pertaining to outfits, etc.; cleanliness, precautions against dampness, cold, heat, malaria, infectious, crude or ill cooked food, etc." The commission was ordered by the secretary of war, approved by the President, June 9, 1861, and organized June 13, 1861. (See SANITARY COMMISSION.) Similar organizations also existed in the South during the war.

In 1866 a great stride was made in municipal health legislation by the establishment in New York City of the Metropolitan Health Board; an organization modelled after the English Sanitary Act, with ample powers to make such reforms as would secure the health of the people. Its first practical work was an apparently successful contest with the Asiatic cholera, which occurred that year, thereby allaying apprehension at the time, if not for the future. Town or city boards of health (generally for quarantine purposes) had existed for many years in the large maritime cities, and more or less effort was made to suppress nuisances, obtain vital statistics, etc., but no State board of health was created till Massachusetts, in 1869, took the lead followed by California and Virginia, 1871; Minnesota, 1872; Louisiana and Michigan, 1873; Alabama, Georgia, and Maryland, 1875; Colorado, New Jersey, and Wisconsin, 1876; Illinois, Mississippi, and Tennessee, 1877; Connecticut, Kentucky, Rhode Island, and South Carolina, 1878; Delaware and North Carolina, 1879; Iowa and New York, 1880; Arkansas, Indiana, New Hampshire, and West Virginia, 1881; Texas, 1882; Missouri, 1883; Kansas, Maine, and Pennsylvania, 1885; Ohio, 1886; Vermont, 1888. Several of the earlier boards have been reorganized and made more efficient. A board of health for the District of Columbia was authorized by Congress in 1871.

The public agitation of the preservation of health by hygienic measures, and the interest taken in the subject by those in authority, led to the organization of the American Public Health Association in 1872, whose object as stated by its constitution "shall be the advancement of Sanitary Science and the promotion of organizations and measures for the practical application of public hygiene," and its "members shall be selected with special reference to their acknowledged interest in, or devotion to, sanitary studies and allied sciences, and to the practical application of the same." After its third annual meeting its success was assured, and its influence has marked the progress of sanitary work beyond the most sanguine hopes of its projectors. Its membership numbers over 1000, comprising

many of the brightest minds in sanitary work—doctors, lawyers, editors, executive officers of cities and towns, sanitary engineers, sanitary plumbers, and house-builders, etc. Its reports and papers are teeming with information of the most valuable and varied character, and its annual meetings continue, as from the first, to stimulate the formation of boards of health, sanitary associations, and publications diffusing useful knowledge throughout the country. One of its members, Mr. Henry Lomb, of Rochester, New York, has for several years past given prizes aggregating some \$1500 for the best essays upon sanitary subjects, such as "Healthy Homes and Foods for the Working Classes," "The sanitary conditions and necessities of school-houses and school life," "The preventable causes of disease, injury, and death in American manufactories and workshops, and the best means and appliances for preventing and avoiding them," etc.

In 1875 the disinfection of houses and premises by means of carbolic acid spray or steam atomizer, and of streets by cart-tank and sprinkler, was practised in New Orleans. Ship's holds were disinfected by means of burning brimstone and a blower (similar to a blast furnace) forcing the sulphurous gas into every part of the vessel. At New York City the sanitary inspection and disinfection of vessels and care of the sick arriving in them had long been substituted for detention or "quarantine." In 1876, during the "Centennial International Medical Congress," held in Philadelphia, hygiene was somewhat discussed, but no great progress was made in popularizing sanitary work, though the "general subject of quarantine, with particular reference to cholera and yellow fever," was presented in an address by Surgeon General John M. Woodworth, of the Marine Hospital Service, who in conclusion submitted six propositions for the consideration of the section on sanitary science, which, after a lengthy discussion, were adopted, as follows:

I. The supervision of ocean travel ought to be directed to securing good sanitary conditions for vessels at all times out of as well as in port.

II. A system of port-sanitation should be adopted and administered for each country or place, separately, and should be modified in particular cases by taking into account the liability of the port to infection, the period of incubation of the disease, the length of time consumed in the voyage, the measures enforced by the vessel *en route*.

III. In some countries the detention of passengers and crews of ships hailing from infected ports is warranted, but for such time only as is necessary to complete the period of incubation of cholera or of yellow fever, counting from the date of departure from an infected port, or of landing from an infected vessel; in no instance should passengers or sailors be held for observation on board an infected vessel, and such vessel should not be detained beyond the period required for inspection, and for thorough disinfection and cleansing.

IV. Recognizing the fact that the morbid causes of infectious diseases may sometimes elude the most vigilant sanitary supervision of shipping, the importance of wisely directed internal sanitary measures can scarcely be over-estimated.

V. As far as America is concerned, it is desirable that prompt and authoritative information should be had of the shipment of passengers or goods from districts infected with cholera or yellow fever, thereby insuring the thorough disinfection of infected articles.

VI. The endemic homes of cholera and yellow fever are the fields which give the greatest promise of satisfactory results to well-directed and energetic sanitary measures; and to this end an international sentiment should be awakened, so strong as to compel the careless and offending people to employ rational means of prevention.

These propositions, submitted twelve years ago, are the basis upon which sanitarians are now working to advance sanitary science at home and abroad.

At this congress the subject of "germ disease" was considered in an address by Dr. Thos. E. Satterthwaite, of New York, who stated that there were three theories: (1) The vegetable-germ theory;

(2) That disease-germs were degraded parts of animal tissue which divided and subdivided "as live matter alone divides." (3) The physico-chemical theory. He explained these different theories at length, and stated that attention was first called to the "cholera-fungus" in 1849; that Hallier and others described the "cholera micrococcus," in 1867, as a granular mass which underwent a variety of changes in form, but that no agreement had been reached by investigators as to the specific form, and that experiments made by himself in 1873 failed to find microscopic changes in molecular matter. He then submitted the following "conclusions:":

I. As far as inquiry has been made as to the nature of the active principle in infective diseases it is probable that in a certain number the matter is particulate or molecular in form.

II. That in regard to the causes of septicæmia, pyæmia, puerperal fever, erysipelas, and hospital gangrene, and those of cholera, vaccine diseases, the carbuncular diseases of men and animals, typhoid and relapsing fevers and diphtheria, there is not satisfactory proof that they are necessarily connected with minute vegetable organisms.

III. That the real nature of these causes is still uncertain.

Dr. John L. Atlee, in a report on the cholera epidemic of 1854, made the following year to the sanitary committee of Lancaster County, Pa., states that microscopical examinations of the rice-water discharges from both the stomach and bowels disclosed *minute bodies* differing in appearance from epithelial cells, and from known physiological and pathological, histogenic, and phylogenetic elements. (*Transactions of the Medical Society of the State of Pennsylvania*, 1855, vol. v. p. 108.) He is reported to have lately said (1888) that these "minute bodies" are identical with the now well-known comma-bacilli of Koch, but that he does not believe they are the cause of cholera, and "so far, no convincing proof of the germ theory of disease, as applied to living tissues and living phenomena has been produced." (*Annals of Hygiene*, Aug. 1888, p. 310.)

The progress of sanitary science in the United States was again stimulated and advanced as a result of the ravages of yellow fever in Memphis, Tenn., in 1878-79. Many bills were introduced in Congress at that time with a view to preventing future epidemics by national sanitary legislation, and on April 29, 1878, "An Act to prevent the introduction of contagious or infectious diseases in the United States" became a law. It provided that no vessel coming from a foreign port where contagious or infectious disease may exist, or carrying persons, merchandise, or animals affected with such disease, shall enter any port of the United States, contrary to the quarantine of such State, except in the manner to be prescribed by regulations; required consular officers or other agents of the government to immediately notify the surgeon-general of the Marine Hospital Service of the departure of such vessel from an infected port, and also notify the health officer at port of destination; required consular officers to make weekly reports of the sanitary condition of their respective ports. Rules and regulations were to be framed by the surgeon-general, and when approved by the President, medical officers of the Marine Hospital Service and custom officers were directed to aid in enforcing the same. Weekly abstracts were to be made by the surgeon-general of consular sanitary reports and other pertinent information received by him. It provided further, that officers or agents of State or municipal quarantine systems, on application, may be authorized to act as officers or agents of the national quarantine system. No appropriation was made by Congress to carry out the provisions of the law, though a *Public Health Bulletin* containing a weekly abstract of consular reports was published by the Marine Hospital Service in accordance therewith.

On March 3, 1879, after much public discussion and outside pressure, Congress created a National Board of Health. The Board was composed of seven members appointed by the President, and confirmed by the Senate, and one medical officer each of the Army, Navy, and Marine Hospital Service, and one officer from the Department of Justice. As defined by the law its duties "shall be to obtain information upon all matters affecting the public health, to advise the several departments of the government, the executives of the several States, and the commissioners of the District of Columbia on all questions submitted by them or whenever, in the opinion of the Board, such advice may tend to the preservation and improvement of the public health." It also directed that the Board, with the assistance of the Academy of Science, shall prepare a plan for a national public health organization after consultation with the principal sanitary organizations and sanitarians of the several States, special attention to be given to the subject of quarantine, both maritime and inland, and as to the regulations which should be established between State or local systems of quarantine and a national quarantine system, and appropriated \$50,000 to carry out the purposes of the act. An additional act was passed and approved June 2, 1879, temporarily suspending the act of April 29, 1878, and enlarging the duties of the National Board of Health to cover the provisions of that act. The Board having organized, at once commenced investigations into the causes of disease, into the sanitary condition of cities, etc., prepared rules and regulations to be observed in case of epidemics, established refuge stations at the following points: Ship Island, Gulf of Mexico, Sapelo Sound, Ga., Norfolk, Va.; appointed a commission to visit Havana, and investigate yellow fever in Cuba; secured the presence of an International Sanitary Conference in Washington in 1881, and stimulated the formation of State Boards of Health. It employed sanitarians and experts in various investigations, and made many valuable contributions to sanitary science. (See *Reports National Board of Health*, Vols. I.-V., 1879-83.) The law creating the Board is still on the statute book, but the act of June 2, 1879, having expired by limitation in 1884, and no appropriation having been made for its maintenance, it is now a board only in name. By the expiration of said law, that of April 29, 1878, was revived, and is now in active operation, having been recently perfected (Aug. 1, 1888) by additional legislation establishing national quarantine stations at the following points: Chandeleur Island, Gulf of Mexico, near Key West, coast of Georgia, entrance Chesapeake Bay, mouth Delaware Bay, San Diego, Cal., San Francisco, Port Townsend, Oregon. It is made a misdemeanor punishable by fine or imprisonment, or both for the master, pilot, or owner of any vessel entering a port of the United States in violation of the act or regulations framed under it.

This chronological history of the progress in sanitary science in the United States has been necessarily very brief, and it will be observed that "quarantine" (which as now conducted is a sanitary institution) has been included. At the present time, and for ten years past, the "germ theory of disease" has commanded much scientific attention, and given to the subject of sanitary science an exhaustless field for research and speculation. (See BACTERIA and GERM THEORY.) It may here be stated that the theory is that a living germ, microscopical in size and of almost infinite self-multiplication, invades the human organism and by its presence gives rise to pathological changes, resulting in different manifestations of disease depending on the species that is migrating—to the alimentary canal (especially the intestines) in cholera, to the lungs in

tubercle, etc. It is not generally believed that this germ arises *de novo*, but that it is transmitted from person to person through the medium of air, food, or water, and finds its lodgment with an unerring instinct of "selection," dependent, as is above stated, upon the species that is migrating. But there are those who believe that these germs are the result and not the cause of disease, and that while germicides may destroy the bacteria they have little or no influence in arresting disease or limiting the progress of an epidemic. Contending that if it can be proved that living organisms (microbes) are the cause of contagious, infectious, or other diseases, and that each disease can be diagnosed by the presence of a particular species of bacteria, it only remains to find and be able to apply a suitable germicide for each species and its spores in order to banish all such diseases from the face of the earth.

The following is a list of the "recognized" pathogenic germs (micro-organisms):—

- Bacillus anthracis (Chavcau and Davalue), malignant pustule;
- Bacillus coli communis (Hueppe), cholera nostras;
- Bacillus lepræ (Danclson and Boeck);
- Bacillus mallei (Loeffler), glanders;
- Bacillus tuberculosis (Koch, 1882);
- Bacillus typhi abdominalis (Eberth and Gaffky), typhoid fever;
- Diplococcus pneumonia (Frankel) (first discovered by Surgeon Sternberg, U. S. A.);
- Micrococcus gonorrhœa (Nelsesen);
- Micrococcus pyæmia (Koch);
- Plasmodium malaria (Laveran, Councilman, etc.);
- Spirillum cholerae Asiaticæ (Koch, 1884);
- Spirillum Obermyeri, relapsing fever;
- Staphylococcus pyrogenus aureus, staphylococcus albus, staphylococcus citreus (osteomyelitis);
- Streptococcus crystallicus;
- Streptococcus phlegmon;

The following is a list of germs claimed by some to exist, but not yet established as causing disease:—

- Bacillus malarie (Tommasi and Crudell);
- Bacillus scarlatina;
- Bacillus of syphilis;
- Bacillus of tetanus;
- Micrococcus of yellow fever (Frelre);
- Micrococcus of beri-beri;
- Micrococcus of dengue;
- Micrococcus of diphtheria;
- Micrococcus of parotitis (mumps);
- Micrococcus of scarlatina;
- Micrococcus vacæna;
- Micrococcus variolæ.

The foregoing lists were prepared by Dr. J. J. Kinyoun, Assistant Surgeon, U. S. M. H. S.

Whether or not germs are the cause or propagators of certain diseases, it has been pretty well established that thorough disinfection and cleansing of a room in which smallpox, scarlet fever, or diphtheria has occurred appears to render it safe for occupancy by a person who has never suffered with these diseases; but on the other hand anti-germ theorists claim that it has not yet been clearly demonstrated that disinfection alone will prevent the spread of yellow fever or cholera.

Before leaving this interesting subject it may be stated as the consensus of opinion among scientists that the "germ theory of disease" has been clearly demonstrated, and that the "microbe" is the *materies morbi* which must be sought for and destroyed in all so-called zymotic diseases.

Ptomaines.—This name was given by the Italian chemist and toxicologist, Francesco Selmi, to certain chemical compounds, basic in character, resulting from the putrefactive decomposition of organic matter. What concerns the sanitarian more particularly is that they are found in poisonous quantities in impure milk, cheese, ice-cream, meats, fish, etc. The name is derived from the Greek word *πτῶμα* (cadaver), as experiments upon decaying human bodies disclosed alkaloids, both poisonous and inert, similar

to those subsequently discovered in articles of impure food. Briefly stated, distinguished chemists and scientists have for over half a century endeavored to isolate the poisonous principle of putrefying organic matter. Prof. Panum demonstrated that the poison of decomposing flesh is not volatile, is not destroyed by boiling, is insoluble in alcohol but soluble in water, and that its intensity is comparable to that of the venom of serpents, of curare, and certain vegetable alkaloids, and that it contains no living organism. It has further been demonstrated that ptomaines are the result of putrefactive decomposition, and that bacteria are the active agents of this process (Pasteur), also that it depends on the kind of bacteria, the degree of putrefaction, and perhaps the atmospheric conditions, whether the ptomaine is poisonous or inert. Prof. Brieger, of Berlin, obtained a toxic ptomaine from cultures of typhoid bacillus which had the composition of $C_7H_{17}NO_2$; and, although this bacillus would produce a poisonous ptomaine when cultivated in beef tea, it did not produce any ptomaine when cultivated in solution of peptone, where it grew equally as well. The following ptomaines, among others, have been isolated, and their composition determined: from putrid flesh, neuridine ($C_5H_{11}N_3$) and neurin ($C_5H_{13}NO$), the former inert and the latter poisonous; from decomposed fish, muscarine ($C_5H_{15}NO_3$) and gadanine ($C_6H_{17}NO_{21}$), the latter inert; rotten cheese and decomposed glue gave neuridine; the cadaver gave six different inert and three highly poisonous ptomaines, depending upon the different stages of decomposition of the cadaver; from mussels, mytilotoxine; from putrefying yeast, sepsin; from impure milk, cheese, and ice-cream, tyrotoxin. The latter poisonous ptomaine was isolated by Victor C. Vaughan, Ph.D., M.D., of Ann Arbor, Mich., in 1885-86; the numerous and heretofore incomprehensible poisonings from these articles leading him to make a thorough and exhaustive examination into their cause, resulted in this brilliant discovery, which has since been confirmed by a number of other distinguished chemists. It is quite possible that the great poisoning of the guests at the National Hotel in Washington, D. C., many years ago, was caused by ptomaines in the milk. It has also been suggested that ptomaines are the active agents in septicæmia.

The foods in which poisonous ptomaines are found, according to Vaughan, are mussels, sausage, ham, canned meats, fruits and vegetables, cheese, milk, and ice-cream.

1. **Mussels**, of which there are three varieties, one kind producing gastro-intestinal irritation; in the second and most frequent variety the symptoms are of a nervous character, with a sensation of heat and itching, followed by an eruption and distressing asthmatic breathing; the third kind produces an intoxication similar to alcohol, followed by paralysis, coma, and death.

2. **Sausage**.—Poisonous sausage, also known as *botulismus* and *allantotoximum*, gives symptoms of a diversified character. There is difficulty of breathing and of swallowing, nausea, vomiting, vertigo, dilatation of the pupils, small, rapid, and thready pulse, nervous prostration and debility, delirium and coma, resulting in a mortality of over fifty per cent.

3. **Hams**.—The ptomaine in putrefying ham has not yet been isolated, but the "Wellbeck poisoning" a few years ago demonstrated that it exists and is potent in energy.

4. **Canned meats, fruits and vegetables**.—The ptomaine may be developed after the can is opened if its contents are not immediately used, or putrefaction may be in progress when canned, or it may be completed when it reaches its destination.

5. **Cheese**.—After many attempts Prof. Vaughan

succeeded in isolating the poisonous ptomaine of cheese. From sixteen kilograms of one cheese he obtained 0.5 grain of the poison and the individual crystals were plainly visible to the eye. Some 300 cases of poisoning occurred in Michigan from eating twelve different cheeses, nine from one factory and one each from three others. Prof. Vaughan says: "The cheese was in good condition, and there was nothing in the taste or odor to excite suspicion. However, from a freshly cut surface there exuded numerous drops of a slightly opalescent fluid which reddened litmus instantly and intensely." Surgeon Sternberg, U. S. A., found numerous micrococci in this fluid, "but inoculation of rabbits with these failed to produce any results." Wallace and Wolf have each, more recently, detected tyrotoxin in cheese, the one in Jeansville, Pa., and the other in Shamokin, Pa. The symptoms of poisoning are dryness and constriction of the throat, vomiting of thin watery fluid, with diarrhoea and watery stools, pulse feeble and irregular, countenance pale with marked cyanosis, tenderness over the stomach, and other symptoms similar to those of arsenic poisoning.

6. *Milk*.—Following Vaughan's discovery, Newton and Wallace obtained poisonous ptomaines from milk used at the hotels at Long Branch when fifty-four persons were poisoned at two hotels in that place in 1886. Their report is of great value, but lack of space forbids its reproduction here. In Corning, Iowa, the same poison was recently found by Shearer in milk used at a hotel, and in the vomited matter of those who drank it. The symptoms of poisoning are similar to those from cheese poisoning.

Ice-cream.—Vaughan obtained tyrotoxin from cream which poisoned many persons at Lawton, Mich., in 1886; so also did Novy. It was at first thought that vanilla caused the trouble, but this was soon proved to be a mistake, and the poisonous ptomaine (tyrotoxin) was isolated from the cream. An interesting account is given by Allaben, of poisoning by lemon ice-cream, and by Shearer of poisoning by both lemon and vanilla cream. The symptoms of poisoning are similar to those of cheese and milk poisoning.

Stale fish.—The London *Lancet* of Feb. 20, 1886, gives an account of poisoning by stale fish in which ptomaine was found both in the fish and the contents of the stomach, intestines, liver, blood, brain, and urine of the victims.

Certain diseases, it is believed, may be caused by ptomaines: Anthrax, cholera, tetanus, typhoid fever, and cholera infantum; there would seem to be good ground for believing that cholera infantum may result from tyrotoxin, which, as Vaughan says, is strengthened by "the fact that infants nourished exclusively from the mother's breast are most wholly exempt from this disease."

As ptomaines are the result of putrefactive decomposition, and as bacteria are the cause of the latter (Pasteur), it is necessary to destroy the germs to prevent the formation of the former, particularly as nearly all ptomaines are indestructible by the most powerful disinfectants, and are not rendered harmless by boiling. Vaughan however states that, "in exceptional cases, as in milk containing tyrotoxin, boiling the milk will destroy both the germ and the ptomaine." The sanitarian, however, will avoid being poisoned by ptomaines by obtaining his meats and fruits fresh, his cheese, milk, and ice-cream pure: this he will do by knowing where the meats are cured or canned, and the condition of the dairy from which his cheese and milk are obtained.

The value of the discovery of ptomaines as a cause of poisoning will lead to a more careful inspection of our foods, particularly of cheese, milk, and cream,

and at the same time remove the suspicion which may have hung over many communities that their people were subjected to wholesale poisoning by some secret enemy. In a medico-legal investigation its importance is evident.

Domestic hygiene is the fundamental principle underlying public health—the family is the unit of the nation—the fountain must be pure, or they seek in vain who try to purify the stream. Sanitary science then should be taught at home, in the school-room, the college, and the university, commencing with the care of the infant and continuing to that of the child and adult. Personal cleanliness, attention to the secretions and excretions, bodily exercise, proper food, drink, apparel, and domicile should each be considered.

Public hygiene, or the conditions necessary for the health of communities, includes the study of, 1. The climate and how to render its vicissitudes less dangerous. 2. The telluric conditions and surroundings and how to render the land and air dryer by drainage. 3. The site or location of dwellings, the material of which they are built, their heating, lighting, and ventilation. 4. The arrangements of streets and alleys, their paving, cleansing, and repair. 5. The water supply, where and how obtained and distributed, its quality and quantity, and the disposal of house-waste and sewage. 6. The food supply, markets, slaughter-houses, bakeries, canned and condensed-food factories. 7. The effects of trades, manufactures, and other pursuits or employments. 8. The location, construction, internal arrangement and condition of tenement-houses, and public buildings, including churches, school-houses, hospitals, and prisons. 9. The management of contagious and infectious diseases, vaccination, isolation, disinfection, and house-to-house sanitary inspection. 10. Vital statistics, registration of births, marriages, and deaths. 11. Disposal of the dead, inhumation, cremation, coking, embalming, and electro-plating.

Probably the most important factors in the propagation of disease may be found in the water supply of cities and in the disposal of their sewage. The pollution of rivers and other sources of supply has long engaged the attention of sanitarians and others, and plans for the disposal of sewage in some other manner than by depositing it in the adjacent water-courses have from time to time been tried. When it is remembered that in the large cities of the United States the present plan for the disposal of sewage not only pollutes the water-supply of its own or of neighboring towns, but involves the whole city in a network of filthy sewers which underlie the streets, enter the dwellings, and contaminate the very air we breathe, it would seem that the time had arrived for adopting some other plan for its disposal than that of emptying it into the water we drink, and having its filthy emanations infecting our dwellings. Sanitary science has pointed out the remedy, but the general adoption of it is difficult to accomplish, perhaps will not be attained for many years. It is simply to collect the excrementitious products (feces and urine) in suitable vessels and either use them as a fertilizer, or destroy them by cremation. The former plan is much the cheaper and is said to be almost self-supporting. In Japan it is done at a profit to the householder who is paid for the deposit. The latter is safer on account of the possible propagation of such diseases as cholera and typhoid fever by the "germs" finding their way back into the drinking water of out-lying villages or farms where the fertilizer is used. Omitting the pneumatic system of Llernur, which requires water-closets, soil pipes, and faecal reservoirs, there are two plans which have been approved by sanitarians as satisfactory

See Vol. XI, p. 566 (p. 600 Am. Rep.); also Vol. XX, p. 96 (p. 101 Am. Rep.).

for securing the fecal deposits for fertilizing purposes, the "pail" system, better known as the "Rochdale," and the earth or ash-closet system ("commode"), first introduced by Rev. Henry Moule of England. Both of these systems are in use to a moderate extent in this country and are rapidly growing in favor. Heap's patent dry earth or ashes closet, with its automatic urine separator and self-acting hopper, requires less earth for deodorizing purposes and therefore is better adapted for use where earth or ashes cannot readily be obtained. Both of these systems have been extensively used in England. Manchester (including Salford), with a population of nearly 800,000 souls, is said to contain but 11,000 water-closets against 66,000 pail-closets, notwithstanding the fact that it is thoroughly sewered, has an abundant water supply, and the Irwell river courses through it. The other plan, cremation, includes the destruction, not only of the feces, but of all kinds of house refuse, garbage, broken crockery, street sweepings, dead animals, etc., which are dumped into a "destructor" where all is reduced to ashes except the old pots, pans, crockery, glassware, etc., which becoming fused together are broken up and used for making roads, or ground and made into bricks, etc. For the disposal of sewage by water and a description of earth-closets see *ENCYCLOPEDIA BRITANNICA*, Vol. XXI., p. 717 (p. 745, Am. Rep.). The filtration of water by the "Hyatt pure water system" is regarded as satisfactory where it is found that any impurities exist in the general water supply. For domestic purposes there are many kinds recommended.

Heating and Ventilating of houses, public and private, are now regarded as most important problems by the architect in preparing his plans. (See "Heating" in the *BRITANNICA*, and *VENTILATION* in this work.) Many experiments have been tried, all systems having for their object the introduction of pure air properly heated, and the expulsion of the vitiated air resulting from the respiration and the emanations of its occupants, this interchange must be imperceptible or a feeling of discomfort arises from the draught created. "Gouge's system of ventilating and heating," and the Ruttan-Smead system, based on scientific principles, are commended as among the best. The general subject is too extensive to consider here.

Disinfectants. (See this title in the *ENCYCLOPEDIA BRITANNICA*, and in this work.) These are agents used for destroying the infectious material (germs) of infectious diseases, and should not be confounded with deodorizers or antiseptics which simply destroy bad odors or arrest putrefactive decomposition. Admitting the "germ theory of disease" to be correct, the exhaustive exposition of the present knowledge on this subject, made by the chairman of the committee on disinfectants appointed by the American Public Health Association, Major George M. Sternberg, Surgeon U. S. A., is a contribution to Sanitary Science of incalculable value, as in fact is the entire report of the committee. (See *Public Health Papers and Reports of the American Public Health Association*, Vol. XIII., pp. 64 to 201. Concord, N. H., 1888.)

Space can here be given only for the "conclusions" of the committee, as follows:—

"The most useful agents for the destruction of spore containing infectious material are: 1. Fire; complete destruction by burning. 2. Steam under pressure, 105° C. (221° F.) for ten minutes. 3. Boiling in water for half an hour. 4. Chloride of lime (which should contain at least 25 per cent. of available chlorine), a 4 per cent. solution. 5. Mercuric chloride, a solution of 1:500.

"For the destruction of infectious material which owes its infecting power to the presence of micro-organisms not containing spores, the committee

recommends: 1. Fire; complete destruction by burning. 2. Boiling in water for ten minutes. 3. Dry heat, 110° C. (230° F.) for two hours. 4. Chloride of lime, a 2 per cent. solution. 5. Solution of chlorinated soda (containing at least 3 per cent. of available chlorine), a 10 per cent. solution. 6. Mercuric chloride, a solution of 1:2000. 7. Carbolic acid, a 5 per cent. solution. 8. Sulphate of copper, a 5 per cent. solution. 9. Chloride of zinc, a 10 per cent. solution. 10. Sulphur dioxide, which will require the combustion of between three and four pounds of sulphur for every 1000 cubic feet of air space. There should be exposure for twelve hours to an atmosphere containing at least 4 volumes per cent. of this gas in presence of moisture.

"The committee would make the following recommendations with reference to the practical application of these agents for disinfecting purposes: *For excreta.* (a) In the sick-room: 1. Chloride of lime in solution, 4 per cent. In the absence of spores: 2. Carbolic acid in solution, 5 per cent. 3. Sulphate of copper in solution, 5 per cent. (b) In privy vaults: 1. Mercuric chloride in solution, 1:500. (The addition of an equal quantity of potassium permanganate as a deodorant, and to give color to the solution, is to be recommended.) 2. Carbolic acid in solution, 5 per cent. (c) For the disinfection and deodorization of the surface of masses of organic material in privy vaults, etc.: Chloride of lime in powder.

"*For clothing, bedding, etc.* (a) Soiled underclothing, bed linen, etc.: 1. Destruction by fire if of little value. 2. Boiling for at least half an hour. 3. Immersion in a solution of mercuric chloride of the strength of 1:2000 for four hours. 4. Immersion in a 2 per cent. solution of carbolic acid for four hours. (b) Outer garments of wool or silk, and similar articles, which would be injured by immersion in boiling water or in a disinfecting solution: 1. Exposure in a suitable apparatus to a current of steam for ten minutes. 2. Exposure to dry heat at a temperature of 110° C. (230° F.) for two hours. (c) Mattresses and blankets soiled by the discharges of the sick: 1. Destruction by fire. 2. Exposure to superheated steam, 105° C. (221° F.) for ten minutes (mattresses to have the cover removed or freely opened). 3. Immersion in boiling water for half an hour.

"*Furniture and articles of wood, leather, and porcelain.* Washing, several times repeated, with: 1. Solution of carbolic acid, 2 per cent.

"*For the person.* The hands and general surface of the body of attendants of the sick and of convalescents should be washed with: 1. Solution of chlorinated soda diluted with nine parts of water, 1:10. 2. Carbolic acid, 2 per cent. solution. 3. Mercuric chloride, 1:1000.

"*For the dead.* Envelop the body in a sheet thoroughly saturated with: 1. Chloride of lime in solution, 4 per cent. 2. Mercuric chloride in solution, 1:500. 3. Carbolic acid in solution, 5 per cent.

"*For the sick-room and hospital wards.* (a) While occupied wash all surfaces with: 1. Mercuric chloride in solution, 1:1000. 2. Carbolic acid in solution, 2 per cent. (b) When vacated, fumigate with sulphur dioxide for twelve hours, burning at least 3 pounds of sulphur for every 1000 cubic feet of air-space in the room; then wash all surfaces with one of the above-mentioned disinfecting solutions, and afterwards with soap and hot water; finally throw open doors and windows and ventilate freely.

"*For merchandise and the mails.* The disinfection of merchandise and of the mails will only be required under exceptional circumstances; free aeration will usually be sufficient. If disinfection seems necessary, fumigation with sulphur dioxide will be the only practicable method of accomplishing it without injury.

"Rags. (a) Rags which have been used for wiping away infectious discharges should at once be burned. (b) Rags collected for the paper-makers during the prevalence of an epidemic should be disinfected before they are compressed into bales by: 1. Exposure to superheated steam of 105° C. (221° F.) for ten minutes. 2. Immersion in boiling water for half an hour.

"Ships. (a) Infected ships at sea should be washed in every accessible place, and especially the localities occupied by the sick, with: 1. Solution of mercuric chloride, 1:1000. 2. Solution of carbolic acid, 2 per cent. The bilge should be disinfected by the liberal use of a strong solution of mercuric chloride. (b) Upon arrival at a quarantine station an infected ship should at once be fumigated with sulphurous acid gas, using 3 pounds of sulphur for every 1000 cubic feet of air-space; the cargo should then be discharged on lighters; a liberal supply of the concentrated solution of mercuric chloride (4 ounces to the gallon) should be thrown into the bilge, and at the end of twenty-four hours the bilge-water should be pumped out and replaced with pure sea water; this should be repeated. A second fumigation, after the removal of the cargo, is recommended; all accessible surfaces should be washed with one of the disinfecting solutions heretofore recommended, and subsequently with soap and hot water.

"For railway cars. The directions given for disinfection of dwellings, hospital wards, and ships apply as well to infected railway cars. The treatment of excreta with a disinfectant, before they are scattered along the tracks, seems desirable at all times in view of the fact that they may contain infectious germs. During the prevalence of an epidemic of cholera this is imperative. For this purpose the standard solution of chloride of lime is recommended."

References. Hygiene in America, Bowditch; State Board of Health Reports, Louisiana, 1882-3; American Public Health reports and papers; U. S. Marine Hospital Service reports and papers; U. S. Statutes at Large; Park's Practical Hygiene; Text Book of Hygiene, Rahó; Report of Sanitary Commissions (New Orleans, 1854); Transactions Centennial International Medical Congress; Transactions Ninth International Medical Congress, Vol. IV.; Reports and papers National Board of Health; State and Municipal Boards of Health reports, New York; The Sanitary Era; Annals of Hygiene; and various sanitary publications throughout the United States. (p. ii. b.)

SAN JACINTO, a battle fought on April 21, 1836, between a force of Texans under Gen. Sam Houston (for whom see ENCYCLOPÆDIA BRITANNICA), and a Mexican army under Gen. Santa Aña. The latter on hearing of the independent movement in Texas led an army of 5000 men, determined to crush the opposition to his despotism. He first wreaked his vengeance on the garrison of the ALAMO (q. v.). Houston's men were greatly agitated on hearing of the massacre, and of a second at Goliad where Col. Fannin with 500 men had capitulated on March 27th. Houston sought a position near the mouth of the San Jacinto, where there was a ferry, and there Santa Aña came up with him on April 20th. The Texans, numbering 783 men, all told, had two small cannon. On the morning of the 21st Houston ordered a charge on the Mexican host of 2000, and with shouts of "Remember Alamo!" "Remember Goliad!" the Texans carried all before them. Of the Mexicans 630 were killed and the rest captured. The Texan loss was 8 killed and 25 wounded. Although the Texans clamored for Santa Aña's life, Houston, who had been wounded severely, spared him on condition of his acknowledging the independence of Texas. The treacherous Mexican afterwards tried to repudiate his word, but the war was not renewed.

SAN JOSE, a city of California, seat of Santa Clara co., is 50 miles south of San Francisco, with which it is connected by three lines of railroad. It has a fine court-house, city hall, 2 national banks, 3 other banks, 4 daily and 4 weekly newspapers, 15 churches, 13 schools, the State Normal School, University of the Pacific, and College of Notre Dame. The Leland Stanford, Jr., University, founded here by Leland Stanford, president of the Central Pacific Railroad, in memory of his son, has been endowed with \$20,000,000. Lick Avenue, 28 miles long, leads to Lick Observatory on Mount Hamilton. San Jose was established as a mission by Spanish Franciscans in 1777, but Americans came in 1847 and the city was incorporated in 1850. It is lighted with gas and numerous electric lights, has water-works, and three parks. There is a paid fire department with good apparatus and an automatic fire-alarm system. The property is assessed at nearly \$18,000,000, and the only debt is bonded indebtedness of \$500,000 for the city hall and other improvements. The yearly expense in 1887 was \$371,572. The city has 5 foundries, a woollen mill, flour mill, furniture factory, 3 fruit canneries, and a few factories. The surrounding country produces abundance of grapes, prunes, and other fruits. Wine-making is extensively carried on. The climate of the vicinity is very salubrious, the extreme annual range of the temperature being from 28° to 93°, and the average from 42° to 70°. The population in 1880 was 12,567.

SARATOGA, BATTLE OF. This battle, in virtue of its results, has been classed among the fifteen decisive battles of the world. The British ministry, irritated at the failure of their attempts to crush out the American movement for independence, resolved to effect this by a supreme effort in 1777. So long as the communications between New England and the South remained free this seemed impracticable. It was determined, therefore, to sever these by pouring an army from Canada through the half-open gateway of Ticonderoga, whence they should sweep southward, and, by effecting a junction with Howe, who held New York, interpose a barrier between these sections of the Union.

Gen. John Burgoyne, who was entrusted with the carrying out of the scheme, stood, on June 1st, at the foot of Lake Champlain with an army of 7000 English, Germans, Canadians, and Indians, while Col. St. Leger was sent up the St. Lawrence to Oswego to penetrate the country from that point, capture Fort Schuyler, and then march down the Mohawk to join Burgoyne in Albany. On Burgoyne's appearance before Ticonderoga, St. Clair, the commander, conscious of his inability to hold the fort, fled towards Fort Edward, the place of rendezvous for the patriots. The British pursued, inflicting a defeat on him at Hubbardton, and Gen. Schuyler, commander of the patriot army of the North, fell back from Fort Edward to Cohoes Falls. Meanwhile St. Leger was besieging Fort Schuyler, but Arnold, who was dispatched with 800 men to its relief, scattered the royalists like autumn leaves.

Such were the circumstances under which the main army of the North was placed at the mouth of the Mohawk in August, 1777. Here Schuyler was superseded by Gates, while Burgoyne, discouraged by the disaster at Bennington and the loss at Fort Schuyler, was halting at Fort Edward in hopes of hearing from Howe. This gave Gates time to advance up the Hudson to Bemis Heights and fortify them for his encampment. By Sept. 15th he stood prepared to receive the foe.

Burgoyne ascended the river by the left bank, crossed it on the 13th and 14th at Saratoga, and, on the 18th, was within 2 miles of Gates and making ready for battle. On the morning of the 12th the rival hosts stood confronting each other posted in

similar order, each stretching from the river over the hills westward. The main body of the Americans was on the right under Gates; the left was under Poor; the centre was mainly made up of Learned's brigade. Morgan's riflemen and Dearborn's infantry stood under Arnold on the heights, nearly a mile from the river. At 10 A. M. Burgoyne advanced his army in three columns, the left consisting of artillery under Phillips, and Germans under Riedesel, the centre and right under Burgoyne himself, but covered by Fraser and Bregman. The Canadians and Indians were sent forward to occupy the Americans in front. Gates remained passive till, urged by Arnold, he gave the word for the Indians to be driven back. Taking this as a permission for a general charge, the Americans rushed like a mountain torrent on the foe. Arnold with Morgan held Fraser while he was straining to reach the American rear. Here the fighting was desperate, but the patriots encountering the British under Burgoyne, and played on by Phillips' guns, were, at 3 o'clock, forced back into their line. For four hours Arnold had maintained the fight with the choicest English regiments. A lull occurred during which both parties drew breath. The English again advanced. The Americans kept within their camp till their foe was on the point of charging, when, springing forth, they drove it back over the intermediate clearing. Night put an end to the conflict. The Americans retired to their intrenchments; the British lay on the battle-field. The loss of the former was 64 killed and 217 wounded, that of the latter rather more than 500. Both claimed the victory, but the British had failed to force their way to Albany.

The two armies lay for several days inactive. On Sept. 29th Gen. Benjamin Lincoln joined Gates with 2000 men, while Burgoyne's army melted away through desertion. In vain did he call on Howe and Clinton. His provisions began to fail; he must fight or flee. On Oct. 7th he determined to make a reconnaissance in force and replenish his stores by foraging. His foragers were discovered and, at 2.30 P. M., the struggle was recommenced. Arnold and Morgan were the inspiring spirits for the patriots, Fraser for the British. At length the last was struck down, and panic seized the royalists, which was augmented by the appearance of 3000 fresh troops under Gen. Tenbroeck. The British were driven within their lines. Both armies were exhausted, the Americans being as incapable of following up their advantage as the British of repairing their discomfiture. The American loss was 150; the British, 700.

The 8th was spent in heavy skirmishing, till, at evening, Burgoyne, leaving his baggage and wounded, set out on a night march for Saratoga. On the 9th he encamped on the heights north of Fishkill. Gates pursued on the 10th and reached the heights between Saratoga church and the Fishkill in the afternoon.

Burgoyne now saw no means of saving his army save by a precipitate flight to Fort Edward, which he hoped to capture. With this view he sent a working-party in advance. Gates, supposing this to be the whole British army in retreat, ordered a general advance over the Fishkill. Burgoyne appreciating his mistake, leaving a guard in his camp, aided by a fog, ambushed his main force in an adjoining thicket. The Americans on crossing were received by a heavy fire. Gates now learned the truth from a deserter and recalled his men to their positions. Burgoyne saw that there was no longer hope of escape. His position was exposed to fire on all sides; the roads to the north were impassable and the woods swarmed with patriots; he had bread only for three days and water was inaccessible. On the 13th he called a council of war and it was

resolved to treat with Gates for honorable surrender. After negotiating, terms were agreed to on the 16th, and, on Sept. 17th, articles were subscribed whereby the British were permitted to march out of the camp with the honors of war, surrendering their artillery, arms, and ammunition, and engaging not to serve again during the war. Burgoyne, in presence of the two armies, in the afternoon, surrendered his sword to Gates who promptly returned it. The British troops then filed off to Boston, whence they were to embark for England. But Congress afterwards refused to carry out the terms of surrender, and the British prisoners were taken to Pennsylvania and Virginia, where they mostly remained till the close of the war. (J. H.)

SARDOU, VICTORIEN, French dramatist, was born at Paris Sept. 7, 1831. The son of a classical professor, he had in early manhood a severe struggle with poverty. He gave lessons in various branches, wrote for reviews, dictionaries, and newspapers, and even composed a play which failed miserably. It was not until his marriage with Mlle. de Brécourt, in 1858, gave him access to the theatre manager Déjazet that he entered fairly on the field in which he achieved a flattering success. His play *Candide* (1860) was soon followed by a shoal of others, produced at various theatres. Among them may be noted *Nos Intimes*, *Les Pattes de Mouche*, *La Perle Noire*. Offenbach contributed the music to his comic operas. Sardou's career was interrupted for a while by the overthrow of the Empire, but early in 1872 he brought out *Rabagas*, a political comedy, in the style of Aristophanes, aimed at Gambetta. Its representation excited serious disturbances in Paris and in the provinces. His noted caricature, *L'Oncle Sam*, was actually prohibited for a time at Paris lest it should produce diplomatic complications with the United States. But when produced in New York, in March, 1873, it caused more astonishment than anger. A later noted comedy, *Daniel Rochat* (1880), turned on the question of religious marriages, various views of which were presented by characters easily recognized. Sardou was chosen a member of the French Academy in June, 1877, and his reception took place May 23, 1878. His most noted later works are *Fédora* and *Théodora*, both written for Sarah Bernhardt. They have proved as popular on the English and American stage as in Paris. Sardou's comedies, struck off rapidly, are full of spirit, and reproduce vividly on the stage the movements of the world around him. With Shakespearean directness and confidence in his right to whatever he finds worth taking he has not hesitated to make use of situations and scenes already employed by others. His popularity has not been in the least affected by this open plagiarism. Sardou was married in 1872 to Mlle. Soulier, daughter of the keeper of the museum at Versailles.

SARGENT, EPES (1812-1880), a prolific author of popular books, was born Sept. 27, 1812, at Gloucester, Mass., where his family had resided for more than a century. In boyhood he visited Russia and for two years he studied at Harvard College. He became connected with the *Boston Daily Advertiser*, but he and his elder brother, John Osborne Sargent, who was afterwards noted as a lawyer, assisted S. G. Goodrich (for whom see ENCYCLOPÆDIA BRITANNICA) in the preparation of the popular series issued under the name of "Peter Parley." Epes Sargent was for many years engaged as a journalist, sometimes in New York and Washington, but mostly in Boston. He and his brother were active in the interest of the Whig party. Epes also wrote for the stage but without marked success, his chief plays being *The Bride of Genoa* (1836), and the tragedies *Velasco* (1837) and *The Priestess* (1855). In his later years his chief occupation was the preparation of readers, speakers, and other school books, which,

by their excellence, obtained wide circulation. He also edited some books of adventure and wrote *Planchette* (1869), an account of spiritualism, in which he was then a believer. At various times he had published volumes of verse, and his *Songs of the Sea* (1849) included the popular song "A Life on the Ocean Wave." His latest poem was *The Woman Who Dared* (1869). Among his novels may be noted *Peculiar* (1863), a tale of the overthrow of slavery. He died at Boston, Dec. 30, 1880.

SARGENT, LUCIUS MANLIUS (1786-1867), temperance advocate, was born in Boston June 25, 1786, being a grandson of Col. Epes Sargent (1690-1762). He studied at Harvard College and was admitted to the bar but did not practice, being possessed of ample fortune. He was a frequent contributor to the *Boston Transcript*, and his antiquarian sketches, *Dealings with the Dead, by a Sexton of the Old School*, were republished in 1856. His *Temperance Tales*, at first issued separately, had extensive circulation in Europe and Australia, as well as at home, and were afterwards collected in various editions. He married a sister of Horace Binney, the eminent lawyer of Philadelphia, and his sons were distinguished in the war for the Union. He died at West Roxbury, June 2, 1867.

SARGENT, WINTHROP (1753-1820), a cousin of the preceding, was born at Gloucester, Mass., graduated at Harvard College in 1771, and after some experience of naval life entered the American army in 1775. He served in the artillery throughout the Revolutionary war and attained the rank of major. After the war he took part in the enterprise of the Ohio Company, and in 1786 was appointed by Congress surveyor of the Northwest Territory. He was adjutant general in St. Clair's army in 1791 and again in Wayne's in 1794, and was first governor of Mississippi Territory, 1798-1802. He died on a voyage from Natchez to Philadelphia, June 3, 1820.

His grandson, WINTHROP SARGENT (1825-1870), was born in Philadelphia, Sept. 23, 1825, graduated at the University of Pennsylvania in 1845 and at the Harvard Law School in 1847. He published a *History of Braddock's Expedition* (1855), *Loyalist Poetry of the Revolution* (1857), with a supplementary volume in 1860, *Journal of the Meeting of the Cincinnati* in 1784 (1851), *Life of Major André* (1861), and *Letters of John Andreus*, 1772-6 (1866). He also contributed to the *North American Review* and other periodicals. He practised law in Philadelphia and afterwards in New York, and died in Paris May 18, 1870.

SARMIENTO, DON DOMINGO FAUSTINO, President of the Argentine Republic, was born at San Juan in 1811. He was one of the opponents of the Dictator Rosas and was banished, but returned in 1836, and established a school for young ladies. He became editor of a newspaper and was again banished by Rosas. He then entered the service of Chili and was sent to Europe to examine and report upon educational institutions and systems. In 1851 he returned to Buenos Ayres, and was colonel of a regiment in the battle of Monto Casseros, by which the power of Rosas was overthrown. Sarmiento then took a prominent part in framing the new constitution of the Argentine Confederation. He was minister of instruction, and afterwards of the interior. He also served as governor of San Juan. In 1865 he was sent as minister to the United States and in 1868 he was peacefully elected president of the Argentine Confederation. An unfortunate war, occasioned by the assassination of Gen. Urquiza, greatly injured the prosperity of his administration. It ended early in 1873 in the victory of the national troops. Sarmiento has published several works on the history of his country. Mrs. Horace Mann's translation of his *Life in the Argentine Republic* (1868) gives his biography.

SARTAIN, JOHN, who has been called the founder in America of mezzotint engraving, was born in London Oct. 24, 1808, and came to the United States in 1830. He was originally an engraver in the line manner, but in 1828 commenced to practise mezzotint, and afterward usually mingled line, mezzotint, and stippling in his plates. For some years he was also engaged in painting portraits in oil and miniatures on ivory. Later he abandoned painting and devoted himself entirely to engraving and literary work. Always exceedingly industrious, he has produced an enormous amount of work for various periodicals, annuals, and illustrated books. Of his large framing prints the best known are *Christ Rejected, after West*; *The Iron Worker and King Solomon, American Inventors*, and *Zeisberger preaching to the Indians, after Schussele*; *John Knox and Mary Queen of Scots, after Leutze*; and *the Battle of Gettysburg, after Rothermel*. In 1843 he became proprietor and editor of *Campbell's Foreign Semi-Monthly and Magazine*, and at the same time he had an interest in the *Eclectic Museum*. During some years after 1848 he was part-owner and editor of *Sartain's Union Magazine* (formerly the *Union Magazine*). He has held office in the Pennsylvania Academy and in various artistic and other societies in Philadelphia, and in 1876 had charge of the art department of the Centennial Exhibition. He has also been the recipient of numerous medals and other honors from various European countries. Three of his children have also chosen art as a profession. His son, SAMUEL SARTAIN, born Oct. 8, 1830, in Philadelphia, is well known as an engraver. His work consists principally of portraits and other illustrations for books, but he has also executed a number of large prints, notably *Clear the Track, after Schussele*; *Christ Blessing Little Children, after Eastlake*, and portraits after Neagle, Sully, and other painters. Another son, WILLIAM SARTAIN, born in Philadelphia, Nov. 21, 1843, also began his career as an engraver, but later turned his attention to painting. His art studies were begun under Schussele and continued in Paris under Léon Bonnat. In 1877 he returned to the United States and became an associate of the National Academy three years later. As a teacher he is widely known, having been instructor in various art schools in New York and Philadelphia. Among his paintings, many of them Oriental or Italian subjects, are *Italian Boy's Head* (1876); *Narcissus* (1878); and *Nubian Sheik* (1879). His daughter, EMILY SARTAIN, born March 17, 1841, in Philadelphia, has also practised both engraving and painting. She studied under Schussele and Luminais, and paints principally portraits. From November, 1881, to February, 1883, she was art editor of *Our Continent*, and she has been principal of the Philadelphia School of Design for Women since 1886. (F. L. W.)

SASSAFRAS, a genus of plants, order *Lauraceae*. Nearly all the plants of this order possess aromatic properties, which are due to the presence of volatile oils. The typical genus is *laurus*, the laurel, but it embraces also cinnamon, cassia, camphor, and sassafras. Sassafras is a corruption of the word *Saxifrage*, which now denotes a widely different family of herbaceous plants. It has but a single species *S. officinale*, which is common throughout the United States, forming a small tree in the North, of about 8 inches diameter of trunk, but in favorable situations southward sometimes reaching a height of 50 or 60 feet, and from 1 to 2 feet diameter. The sexes are dioecious, the leaves and flowers produced from the same buds, the younger branches and under surfaces of leaves downy, the flowers in short, slender racemes, of a pale-green color, antlers with 4 unequal cells. The female flowers possess, in addition to the pistils, six gland-like bodies, an-

swering to the stamens of the male flowers. The tree has a greyish and deeply furrowed trunk, but the young branches are of a beautiful reddish-green hue. The true bark when cut into is of a dark red color like that of Peruvian bark. The tree when old gives rise to many suckers which spring up at a short distance from the trunk, growing to a height of 6 or 8 feet. The leaves of the sassafras are remarkable for their varying forms on the same tree. Those first produced from the bud are oval and entire; the next series are lobed on one side; the last and most numerous have regularly three lobes. The flowers protrude from the sides of the branches below the leaves, the sexes being confined to different trees. The fruit or seed is oval in form, of deep blue color, and contained in small bright red cups, supported by peduncles from 1 to 2 inches long. The seeds when ripe are eagerly devoured by birds.

The sassafras tree is indigenous to every part of the United States east of the Rocky Mountains, and extends far into the Dominion of Canada, where it dwindles to a tall shrub. Every part of the tree has a pleasant fragrance, and a sweetish aromatic taste, which is strongest in the bark of the root. These qualities depend upon an essential oil, which may be obtained by distillation and has been highly valued in medicine. The sassafras early attracted the attention of Europeans from the peculiarity of its foliage and its medicinal properties. One writer called it the ague tree, and its value as a medicine was once held so high that its products commanded an extravagant price. It is said that its strong fragrance was one of the indications borne to Columbus and his followers of the nearness of land, so that it may be claimed to have borne a part in the discovery of America.

The wood of the sassafras is white and tender in young trees, reddish and more compact in older trees. While of little value as timber the wood resists decay and has been used for posts, rails, joists, and rafters, also for trunks, bedsteads, etc., under the belief that its odor drives away insects. Sassafras poles have long been used as poultry roosts for the same reason, the odor being supposed to be disagreeable to hen lice. Another use is for fishing rods, from the toughness and lightness of the seasoned wood. The bark has been used for dyeing, and gives wool a very durable orange color. The young shoots and leaves are highly mucilaginous, and the pith, which is light and spongy and very mucilaginous when chewed, is kept in shops and sold for this purpose. It is also used in water as a drink in inflammatory diseases and as an eye-wash. In Louisiana the leaves are sometimes used as a substitute for okra in making gumbo soup. They are also used in making home-made beer known as root beer, and in some sections as a seasoning for sauces.

The Indians have long used the sassafras bark medicinally and it is still used for this purpose, the root bark being preferred for its strong aromatic properties. It is kept in small fragments for flavoring official preparations, for which purpose also the oil is extracted to the extent of 15,000 or 20,000 pounds annually. Medicinally sassafras is considered an excellent stimulant and sudorific, and was formerly much used in the cure of such complaints as rheumatism, dropsy, and cutaneous eruptions. The fruits of the sassafras are much used by perfumers, who powder them and put them up in small sachets for their agreeable odor. (C. M.)

SAULCY, LOUIS FELICIEN JOSEPH CAIGNARD DE, French orientalist and numismatist, was born at Lille, March 19, 1807. He was educated at the Polytechnic School, and entered the artillery service. Meanwhile his leisure was taken up with archeology and especially numismatics. In 1836 his essay

on the classification of Byzantine coins won a prize from the French Institute, and he was soon enrolled as a member of the Academy of Inscriptions. But his duties as military instructor were also diligently pursued, and in 1838 he became professor of mechanics in the school at Metz. Then he was transferred to Paris to be keeper of the Military Museum. In 1850 he made a visit to Palestine and explored the Dead Sea, of which he published a popular account (2 vols. 1852-54). Though his book had wide acceptance, as had also his later work on the Holy Land (1865), many of his statements were controverted. His researches in the Holy Land are said to have converted him to belief in Christianity. In 1870, on the downfall of the French empire, he accompanied the Empress Eugenie to Chiselhurst, but afterwards returned to his labors in the Academy of Inscriptions. Several of his numismatic works had reference to the Jews and to Palestine, but he had also essays on the coins of the Seleucid kings (1872), the Nabateans (1874), the Roman Republic (1874), and of various French kings. He published treatises on Cæsar's expeditions to Britain (1860), on Herod (1867), the siege of Jerusalem (1866), *Seven Centuries of Jewish History* (1874), and a *Dictionnaire Topographique de la Terre Sainte* (1877).

SAVAGE, JAMES (1784-1873), antiquarian, was born in Boston, July 13, 1784. He graduated at Harvard College in 1803, and was admitted to the bar in 1807. In 1812 he was elected to the State legislature, in 1820 was a member of the State Constitutional Convention, and afterwards held various municipal offices. He was one of the editors of the *Monthly Anthology*, 1806-11. He founded the first savings bank in Boston in 1817, and was treasurer and president of the Massachusetts Historical Society. In 1825 he edited with notes Gov. Winthrop's *History of New England* (2d ed. 1853). His principal work was *A Genealogical Dictionary of the First Settlers of New England* (4 vols. 1860-62). It was pronounced by the *North American Review* "the most stupendous work on genealogy ever compiled." The author died at Boston, March 8, 1873.

SAVAGE, MINOT JUDSON, preacher and author, was born at Norridgewood, Maine, June 10, 1841. He graduated at Bangor Theological Seminary in 1864, and went as a Congregational home missionary to California. Afterwards he supplied a church at Framingham, Mass., and became pastor at Hannibal, Mo., in 1869. His theological views having changed he became pastor of a Unitarian church in Chicago in 1873, and in the next year took charge of the Church of the Unity in Boston. He now belongs to the extreme left wing of Unitarianism, and is a bold exponent of its views. He has been a frequent contributor of both prose and poetry to journals and magazines. Among his books are *Christianity the Science of Manhood* (1873), *The Religion of Evolution* (1876), *Talks about Jesus* (1880), *Belief in God* (1881), *Peliefs about Man* (1882), *The Modern Sphinx* (1883), *The Religious Life* (1886), *Social Problems* (1886).

SAVANNAH, a city and port of entry of Georgia, county-seat of Chatham co., is on the south bank of the Savannah River, 18 miles from the Atlantic Ocean, 32° 5' N. lat., 81° 8' W. long. By rail it is 90 miles from Charleston and 682 miles from Washington. Situated partly on a bluff about 40 feet above the river, it extends 3 miles along the river and over a mile inland. The city is regularly laid out with wide streets crossing at right angles and lined with trees. There are 24 small parks and in the centre Forsyth Place, a park of 30 acres, thickly planted with forest trees, has a handsome fountain and a monument with bronze statue to the Confederate dead. Johnson Square contains a granite obelisk commemorating Gen. Nathaniel Greene, and Monterey Square a marble shaft with a statue of

Liberty, erected to the memory of Count Pulaski, who fell here Oct. 9, 1779. Among the conspicuous buildings are the Custom House, City Exchange, Cotton Exchange, Hodgson Hall, used by the Georgia Historical Society, Masonic Temple, Odd Fellows' Hall, Savannah Hospital, the Catholic Cathedral, the Independent Presbyterian Church, St. John's (Episcopal) Church, and the synagogue of Mickva Israel. Savannah has 2 national and 3 State banks and some private banks, a Board of Trade and Cotton Exchange, 2 daily and 4 weekly newspapers. There are altogether 30 churches, 13 of which are used by colored people. Besides some private academies of high reputation, the county provides public schools, in which instruction is given to whites and blacks separately.

The city has street-railways, gas, and electric lights, a good system of water supply, and a paid fire department. The buildings are chiefly of brick, and many private residences are of handsome architecture. The industrial works comprise iron foundries, saw and planing mills, rice and flour mills, cotton compresses, a cotton mill, paper mill, ice factory, furniture factory, and a lithographic establishment.

The railroads are the Central of Georgia with 2050 miles, and the Savannah, Florida and Western, 634 miles, the latter connecting at Tampa, Florida, with a steamship line to Cuba. Steamships also ply regularly from Savannah to New York, Philadelphia, Baltimore, and Boston. As a cotton port Savannah ranks second in the Union, first in the rosin and turpentine trade, and second in the rice trade. It also ships largely lumber, fruit, and iron ore brought from Alabama. The exports in 1885 amounted to \$45,100,000, and the total trade was estimated at \$90,000,000.

Savannah was founded in 1733 by Gen. James Oglethorpe. It was incorporated as a city in 1789. In the Revolutionary war it was captured by the British Dec. 29, 1778, and evacuated July 11, 1783. In the civil war it was captured by Gen. W. T. Sherman, Dec. 21, 1864. Its population in 1880 was 30,709, and in 1886 by a city census 45,482, of whom 18,817 were colored. (J. H. E.)

SAVINGS BANKS. The first savings bank in the United States was organized in Philadelphia under the title of the "Philadelphia Savings Fund Society." It was a voluntary non-corporate association, composed of a few benevolent and philanthropic gentlemen who associated together for the purpose of receiving and caring for the small accumulations of surplus moneys of poor persons. This society commenced the receiving of deposits in December, 1816; subsequently, in the year 1819, it was granted a corporate franchise by the State of Pennsylvania.

The State of Massachusetts, however, was first to give legislative sanction to the organization of savings banks; this it did in the year 1817. Other States that at early dates granted charters for such institutions were Maryland in 1818, New York, Pennsylvania, Maine, Connecticut, and Rhode Island in 1819, New Hampshire in 1823, Ohio in 1831, Delaware in 1832, New Jersey in 1839 and Vermont in the year 1846. At subsequent periods charters were granted to savings banks by most of the other States. For many years all such institutions were created by special acts of the respective State legislatures, but the tendency of recent legislation has been to provide for their organization and management by general laws.

Excepting the so-called capital stock savings banks, the main features of those institutions are very similar—strikingly so, considering the fact that the savings bank system of the United States is not a connective system, subject to the super-

vision and control of a central authority, but rather a multitude of systems, each regulated by its own special source of authority, a State legislature. As savings banks had their inception in the Middle and Eastern or New England States, they are now most numerous and have reached their highest perfection in those localities. The most reliable data obtainable, from both official and unofficial sources, show the number of savings banks in operation in 1886-1887 to have been 684. The number in each State, together with their aggregate capital, surplus and deposits, is given in Table I.

TABLE I.—SAVINGS BANKS, 1886-87.

STATE, ETC.	Number.	Capital.*	Surplus and Undivided Profits.	Deposits.
Maine	54	\$2,199,862	\$37,215,072
New Hampshire..	66	4,604,680	50,822,762
Vermont.....	28	\$460,000	776,112	15,587,050
Massachusettsia ...	172	12,928,350	291,197,900
Rhode Island.....	37	2,797,248	53,284,821
Connecticut.....	35	4,845,631	97,424,820
New York.....	115	85,633,329	482,486,730
New Jersey.....	25	2,412,877	27,482,135
Maryland.....	2	30,105	14,879	204,125
Dist. of Columbia	1	11,464	634,524
North Carolina ...	1	5,991	374	11,307
Ohio.....	4	383,326	15,065,639
Indiana.....	6	212,550	2,312,013
Iowa.....	37	2,128,693	492,204	9,969,019
Minnesota.....	7	150,000	138,908	3,891,653
California.....	24	4,216,377	2,731,089	70,077,893
Total	664	6,091,166	120,187,883	1,157,867,483
<i>Unofficial.</i>				
Philadelphia.....	5	\$444,700	\$3,811,224	\$42,219,099
Delaware.....	2	269,740	2,771,392
Maryland.....	8	1,142,697	18,816,837
Chicago.....	5	2,655,000	1,488,699	14,061,258
Total	20	3,099,700	6,712,360	77,868,586

* Only 54 savings banks report capital.

While it was purely in the spirit of philanthropy that savings banks were originally organized and operated for many years after their introduction into the United States, they no longer are confined in their operations and influences to the limited field first assigned to them. In late years they have proved attractive depositories for the surplus moneys of all classes, and every effort by legislation or otherwise, to restrict them to dealings with the poor alone, has failed. The widening of the area of their operations so as to embrace a higher order and greater number of beneficiaries has had a salutary effect; yet in many States measures have been adopted tending to prevent such expansion and more closely confine them to their original purposes, but the interests of the banks have proved stronger than restrictive laws, and the savings bank systems of the several States have grown and become strong largely through the patronage of those whom it was sought to exclude. Experience has demonstrated that those institutions lose none of their efficiency as promoters of industry, sobriety and thrift among the poorer classes for the reason that others more favored are allowed to share in their benefits. As a consequence they came to be regarded less as depositories than as organized mediums through which investments in clearly defined securities may be advantageously made.

In the year 1834 the State of Massachusetts en-

acted a general law for the organization and supervision of savings banks. At that date there was probably not more than \$7,000,000 on deposit with all of these institutions in the United States. From 1835 savings banks have occupied the public attention to a greater or less degree and the subject has been a fruitful source of legislation; the earlier of which in most States embraced provisions for the making of reports to disclose the condition of the banks in respect to resources and liabilities; such returns though imperfectly showing their condition were the subject of criticism that resulted in the enactment of laws designed to make them more secure by limiting and restricting the scope of their investments and methods of business. At later periods provisions were made for their supervision by designated State officials and examinations were provided for to ascertain whether investments had been made in accordance with the requirements of law.

Though legislation was neither regular nor uniform, the more important subjects were embraced in that of most States during the twenty years succeeding the passage of the Massachusetts general law in 1834. The attention savings banks attracted as affording desirable places of deposit for surplus moneys, practically subject to repayment on demand, was the primary cause of their being generally used by the public. So large patronage soon lifted well-conducted banks located in cities and populous centres of manufacture and trade out of their previous semi-charitable conditions. The greater demands made on the resources of the banks necessitated the employment of competent salaried clerks and managers and the extension of business hours, a few hours of gratuitous service weekly being insufficient for the transaction of their business. The increased facilities afforded early met with public favor and a phenomenally rapid development followed. The growth of savings banks in the United States for the past sixty years is shown by decades in the following table:—

Year.	Number of Banks.	Number of Depositors.	Amount of Deposits.
1825	15	16,931	\$2,537,042
1835	52	60,058	10,613,726
1845	70	145,206	24,506,677
1855	215	431,602	84,290,076
1865	317	980,844	242,619,382
1875	771	2,359,864	924,037,304
1885	684	3,158,950	1,141,530,578

Prior to the year 1870 the estimated loss to depositors with savings banks throughout the United States, by reason of failures, was but a small fraction of a mill on the dollar of aggregate deposits held by such institutions. During the seven succeeding years, however, savings bank failures were of common occurrence. In the State of New York alone 29 of these banks failed, involving a loss to depositors approximating \$5,000,000. In the other States failures were not so numerous, yet they were comparatively frequent. The inherent weakness of the unsound banks was soon developed by the suspension of industries, the depression of trade, and the depreciation of property and securities generally incident to the monetary panic of 1873, coupled with unusually heavy withdrawal of deposits at so critical a time. The conservatively managed solvent banks were little affected by the strain that forced many of the weak ones into liquidation. The failure of one savings bank after another in rapid succession produced great excitement in the localities affected and public attention was directed to the dangers to arise from the reckless incorporation of such institutions. In the year 1855 only 215 savings banks were in existence throughout the United States, in 1875 the number had reached 771. Within that period the war of the Rebellion occurred, producing

conditions exceptionally favorable to such institutions. The abundance of money and the activity of every branch of industry materially aided the rapid accumulation of deposits. The National government was then a large borrower and its bonds were available for investment by savings banks on the most advantageous terms. In seconding the efforts of the government in its struggle for existence, the cities, counties and towns became borrowers of large sums at high rates of interest; those securities also were generally taken by savings banks. Such conditions produced all elements conducive to prosperity for financial institutions: industries active in every department, an abundant currency and facilities for speedy and profitable investment. The seeming prosperity created and promoted by the war did not of course subside immediately on its termination, and the evil effects of the ill-advised multiplication of savings banks were not made fully apparent until the coming of the panic of 1873, when finance, trade, commerce and industries all became unsettled and the manufacturing districts idle, making necessary the withdrawal of savings wisely accumulated for such a time of trial. The strong banks withstood the depletion of their resources, while the weak and unsound ones were swept away.

In connection with past savings bank failures in the United States, it is a noteworthy fact that but very few failures have been caused by the fraudulent appropriation of deposits. For the most part they have resulted from extravagance and a disregard of the plainest principles of prudent business management, as shown by injudicious loans and investments; made sometimes under sanction of law and sometimes without it, but usually with the purpose in view of promoting the advantage of their depositors, by securing for them higher rates of interest than strictly first class loans and investments would yield.

The weaknesses in the system disclosed by the crisis through which they passed have been provided against for the future by remedial legislation. In nearly all of the States laws have since been enacted to provide more effectual safeguards for the protection of savings banks' depositors, and legislators have responded to urgent demands for more stringent and carefully considered laws for their government. Many States have repealed the special laws under which savings banks previously operated and made provisions for their organization and supervision by general law.

Owing to the numerous failures in New York the Constitution of that State was amended by a vote of the people in 1874, so as to require its legislature by a general law to conform the charters of all savings banks or institutions for savings to a uniformity of powers, rights and liabilities, and require that banks thereafter organized should conform to such general law and amendments made thereto. The organization of savings banks with capital stock was prohibited and the power to pass special charters for banking purposes was taken from the legislature. Trustees of savings banks were prohibited from having any interest, direct or indirect, in their profits or from being interested in any loan or use of any money or property of savings banks with which they were connected. In obedience to the constitutional mandate the legislature of 1875 repealed all special privileges contained in savings bank charters and enacted a stringent and very complete general law for their management, many of the salient features of which have since been engrafted into the laws of other States. As the New York law contains more features common to the laws of all States* a synopsis of its provisions are given.

* In most of the Eastern States savings banks are authorized to invest in bank stock, railroad, and corporation

Savings banks are by law declared to be corporations possessed of the powers and functions of corporations generally and as such may have perpetual succession, sue and be sued, complain and defend in any court of law or equity, appoint such officers, managers, or agents as the business of the corporation requires, provide for the management of its property and the regulation of its affairs, contract and be contracted with, receive money on deposit and invest the same and exercise any additional powers incidental to the business of a savings bank. Not less than thirteen persons can organize, each of whom is required to make a written declaration that he will accept the responsibilities and faithfully discharge the duties of a trustee of the institution if the same shall be authorized by the bank superintendent. This officer has discretionary power in regard to the creating of new banks, being required to determine from the best sources of information at his command, whether greater convenience of access to a savings bank will be afforded to any considerable number of depositors by opening a bank at the place designated, and if the density of the population in the neighborhood and in the surrounding country is such as to afford a reasonable promise of adequate support to the enterprise, and also whether the responsibility, character, and general fitness for the discharge of the duties appertaining to such a trust of the persons named as trustees are such as to command the confidence of the community in which the savings bank is proposed to be located. On authority to transact business being granted the persons designated as trustees have the entire management and control of the affairs of the corporation. Residents of the State alone are eligible as trustees, and whenever a trustee of one bank becomes a trustee, officer, clerk, or employé in any other savings bank, or upon borrowing, directly or indirectly, any of the funds of the bank of which he is a trustee, or becoming a surety or guarantor for money borrowed of or a loan made by the bank, or upon failure to attend regular meetings of the board or to perform any duties devolved upon him as a trustee for six successive months, without having previously been excused by the board, his office becomes vacant. But in the discretion of the board such trustees are eligible for re-election. The board of trustees elect from their number a president and two vice-presidents; and from their number or otherwise, elect or appoint such officers and clerks, whose salaries are fixed by the board, as they may see fit. Vacancies in the office of the trustee are filled by the board, which has power from time to time to make such by-laws, rules, and regulations as may be thought proper for the election of officers, for prescribing their respective powers and duties and the manner of discharging the same; for the appointment and duties of committees, and generally for transacting, managing, and directing the affairs of the corporation. Regular meetings of the board of trustees are required to be held as often as once in each month, at which at least seven trustees must be present. Trustees are prohibited by law from having any interest whatever, direct or indirect, in the gains or profits of their banks, or from, directly or indirectly, receiving any pay or emolument for their services, except that trustees acting as officers, whose duties require and receive their regular and faithful attendance at the bank, may receive such compensation as in the opinion of a majority of the board of trustees shall be just and reasonable; such majority to be exclusive of any trustee to whom compensation is voted; but it is not lawful to pay trustees, as such, for attendance at board meetings. No trustee or officer, for himself or as

stocks and bonds, bonds of cities, and personal securities. In some few States the banks deal in commercial paper.

the agent or partner of others, can borrow the funds or deposits of the bank, or in any manner use the same, except to make current and necessary payments authorized by the board of trustees, nor can any trustee or officer become an indorser or surety, or in any manner an obligor for moneys loaned by or borrowed of his bank.

Savings banks are authorized by law to receive on deposit such sums of money as may be offered by individuals, corporations, or societies; invest the same and pay interest or dividends thereon. On making first deposit, banks furnish to each depositor a pass-book in which all deposits and withdrawals are required to be entered. Such pass-book contains the rules and regulations of the bank, and is legal evidence between the corporation and the depositor as to the terms on which the deposit is made. The sums deposited together with accumulations are required to be repaid to depositors or their legal representatives, after demand, in such manner and at such times and after such previous notice, and under such regulations as the board of trustees may prescribe. The usual provision is for sixty days' notice, which is only demanded in time of panic to allay excitement. While depositors are not restricted as to the number of banks with which they may have accounts, the aggregate amount a single bank can hold to the credit of an individual is limited to \$3000. Such limitation does not apply to deposits made by order of a court of record or a surrogate. Banks may refuse to receive deposits, or at any time return all or any portion thereof. Deposits made by minors or females are held for their exclusive benefit, free from the control or lien of all persons whatsoever, except creditors.

It is made the duty of trustees to regulate the rate of interest or dividends on deposits not to exceed 5 per cent. *per annum*, in such manner that depositors shall receive, as nearly as may be, all profits of the corporation after deducting necessary expenses, and reserving such amount as may be deemed expedient, as a surplus fund for the security of depositors, which to the amount of 15 per cent. of deposits they are authorized to gradually accumulate and hold, to meet any contingency or loss in business from the depreciation of securities or otherwise. When surplus exceeds 15 per cent. of deposits extra dividends may be declared. Savings banks are prohibited from declaring, crediting, or paying dividends or interest except on authority of a vote of the board of trustees. When dividends are declared and credited in excess of the earnings of a savings bank, trustees voting therefor are jointly and severally liable to the bank for the excess so declared.

The securities in which investments may lawfully be made are stocks or bonds or interest-bearing notes or obligations of the United States, or those for which its faith is pledged; 3.65 bonds of the District of Columbia; interest-bearing stocks or bonds of the State of New York and those issued by cities, counties, towns, or villages thereof, and the stocks or bonds of any State in the Union that has not, within ten years, defaulted in the payment of any part of either principal or interest of any debt authorized by any legislature of such State to be contracted. In bonds and mortgages on unincumbered real estate, situate in the State, and worth, at least, twice the amount loaned thereon, but not to exceed 60 per cent. of deposits can be so loaned. In case the loan is on unimproved and unproductive real estate the amount is restricted to 40 per cent. of actual value. No loan on bond and mortgage can be made except upon the report of a committee charged with the duty of investigating the same, who certify the value of the premises according to their best judgment, which report is filed and preserved among the records of the institution.

Trustees are required to invest the moneys de-

posited with them, in the securities enumerated, as soon as practicable, except that, for the purpose of meeting current payments and expenses in excess of receipts, there may be kept an available fund of not exceeding 10 per cent. of the whole amount of deposits, which may be kept on hand, or on deposit with banks or trust companies to an amount not exceeding 25 per cent. of their paid up capital and surplus; or such available fund or any part thereof may be loaned on the pledge of such securities as savings banks are by law authorized to invest in. The real estate that they may hold and convey is such as may be requisite for a banking-house, the cost of which is limited to 50 per cent. of the surplus of the bank, and such as may be purchased at sales upon foreclosure of mortgages owned by the bank, or upon judgments or decrees obtained for debts due to it or in settlements effected to secure such debts.

Trustees are prohibited from loaning the moneys deposited with them, upon notes, bills of exchange, drafts, or other personal securities, and it is unlawful for savings banks to deal or trade in any goods, wares, merchandise, or commodities whatever, except as expressly authorized; or in any manner to

buy or sell exchange, gold or silver, or to collect or to protest promissory notes, or time bills of exchange. And no savings bank can lawfully make or issue any certificate of deposit, payable either on demand or at a fixed day, nor pay any interest except regular quarterly or semi-annual dividends upon any deposits or balances, nor pay any interest or deposits, or portion of a deposit, or any check drawn upon itself by a depositor, unless the pass-book of the depositor be produced, and the proper entry be made therein at the time of the transaction.

Every savings bank is required to make a full report in writing of its condition at least twice in each year, verified by the oaths of the two principal officers of the bank. The reports made for January and July are based on examinations of assets and liabilities made by a committee of not less than three trustees; the accuracy of the examinations is required to be verified by the oaths of the trustees making the same. An accurate balance of the depositors' ledgers is also required to be taken semi-annually, and if there be discrepancies between them and the general ledger of the bank the fact must be stated in the semi-annual report.

TABLE II.—684 SAVINGS BANKS, 1886-87.

RESOURCES.		LIABILITIES.	
Loans on real estate.....	\$457,441,666	Capital stock paid in.....	\$10,090,866
Loans on personal and collateral security.....	145,553,135	Surplus fund.....	119,695,310
Other loans and discounts.....	37,904,817	Other undivided profits.....	7,204,933
Overdrafts.....	90,125	Dividends unpaid.....	193,388
U. S. bonds.....	180,248,754	Individual deposits.....	1,235,736,069
State, county, and municipal bonds.....	215,764,815	Due to other banks and bankers.....	90,783
R. R. bonds and stocks.....	74,408,931	Other liabilities.....	4,649,372
Bank stocks.....	40,067,680		
Other stocks, bonds, and mortgages.....	50,684,227		
Due from other banks and bankers.....	55,109,727		
Real estate, furniture, and fixtures.....	29,630,750		
Current expenses and taxes paid.....	1,761,450		
Cash.....	18,005,235		
Other resources.....	70,980,412		
Total.....	1,377,660,724	Total.....	1,377,660,724

TABLE III.—DEPOSITS OF SAVINGS BANKS IN THE UNITED STATES.

STATES.	1885-86.			1886-87.		
	Depositors.	Amount.	Average.	Depositors.	Amount.	Average.
Maine.....	109,398	\$35,111,600	\$320.95	114,691	\$37,215,071	\$324.47
New Hampshire.....	121,216	47,231,919	389.65	132,714	50,822,762	382.04
Vermont.....	49,453	11,723,775	237.07	53,810	15,537,050	289.67
Massachusetts.....	848,787	274,998,413	323.99	906,039	291,197,900	321.40
Rhode Island.....	116,381	51,816,390	445.23	119,159	53,284,821	447.18
Connecticut.....	256,097	92,481,425	361.12	266,888	97,424,820	365.04
New York.....	1,208,072	457,050,250	378.33	1,264,535	482,486,730	381.55
New Jersey.....	91,681	25,335,780	276.35	98,137	27,482,135	280.04
Pennsylvania.....	143,645	37,530,370	261.27	156,722	42,219,699	269.39
Delaware.....	12,744	2,771,392	217.46
Maryland.....	*77,212	30,542,992	395.57	59,565	19,030,962	319.33
District of Columbia.....	7,605	793,943	104.40	8,245	834,524	101.23
North Carolina.....	*377	11,307	30.00
Ohio.....	*34,553	12,823,374	371.12	*41,059	15,065,659	366.93
Indiana.....	9,933	2,312,013	232.75
Illinois.....	*28,038	14,061,258	501.51
Iowa.....	*39,638	9,969,019	251.50
Minnesota.....	14,361	3,654,528	254.48	15,474	3,402,950	219.91
California.....	*80,489	60,435,919	750.80	*90,245	70,077,899	776.52
Total.....	3,158,950	1,141,530,578	361.36	3,418,013	1,235,247,371	361.39

* Estimated.

The bank superintendent makes annual reports to the legislature of the condition of all of the savings banks in operation in the State; he also, at least once in two years, either personally or by some competent person, visits and examines each savings bank transacting business in the State. The super-

Intendent may cause special examinations to be made whenever he deems it necessary or expedient. On such examinations, persons whose testimony is required may be compelled to appear and testify. If at any time it appears to the superintendent, from examinations or reports, that any savings bank has committed a violation of its charter or of law, or is conducting business in an unsafe or unauthorized manner, he is required to direct the discontinuance thereof, and whenever such corporations refuse or neglect to comply with his order, or whenever it appears that it is unsafe or inexpedient for any such corporation to continue to transact business, or that any trustee or officer of a savings bank has abused his trust, or been guilty of misconduct or malversation in his official position injurious to the bank, or to its depositors, the superintendent communicates the facts to the attorney-general, who institutes such proceedings as the nature of the case requires. The proceedings instituted by the attorney-general may be for the removal of one or more of the trustees, or for the transfer of the corporate powers to other persons, or the consolidation and merger of the corporation with any other savings bank that may be willing to accept of the trust, or for such other relief or correction as the particular facts communicated to him shall seem to require. In the event of a savings bank being put into liquidation, its assets are required to be distributed within eighteen months. The advertising as savings banks, by individuals or corporations, without lawful authority, is prohibited under heavy penalties.

In Table II. are given the aggregates of the several items of resources and liabilities of the savings banks throughout the United States in 1886 and 1887, as shown by the most reliable data obtainable from both official and unofficial sources. (E. A. W.)

SAXE, JOHN GODFREY (1816-1887), wit and poet, was born at Highgate, Vt., June 2, 1816. He graduated at Middlebury College in 1839, became a lawyer, and in 1851 was made State attorney at Burlington, where he also conducted a Democratic newspaper until 1858. He was in much request as a lecturer, especially at college commencements and before literary societies. For these occasions his longer poems were specially adapted, while his mirth-provoking shorter ones appeared in the *Knickerbocker Magazine* and various journals. From them collections were made: *The Money King and other Poems* (1860); *Clever Stories of Many Nations* (1863); *The Masquerade* (1866); *Fables and Legends of Many Countries* (1872); *The Proud Miss McBride* (1873); *Leisure Day Rhymes* (1875). Editions of his *Complete Works* followed; but the poet who once was able to evoke mirth from the gravest themes became a victim to confirmed melancholy. He lived in seclusion at his son's house, in Albany, refusing to receive any company, and died there, March 31, 1887.

SAY, THOMAS (1787-1834), naturalist, was born at Philadelphia, July 27, 1787. He was the son of a druggist and was trained in the same business, but injudicious indorsements caused the failure of his firm. When the Academy of Natural Sciences was formed in his native city, in 1812, he was made curator and devoted himself with such ardor to scientific investigation that he grudged to spend time in eating. In 1818, he joined Maclure and others in exploring the islands and coast of Georgia and Florida, until hostilities with the Indians interrupted the work. Say was chief geologist in Major Long's exploring expeditions, the first in 1819-20, to the Rocky Mountains, to the second, in 1823, to the sources of St. Peter's River, now called the Minnesota. Robert Owen drew Say and Maclure into his socialist scheme at New Harmony, Ind., in 1825. They were to conduct a university for the scientific training of the community. The entire experiment

failed within two years, but Say remained as the agent of the property, and died there, Oct. 10, 1834. His chief work is *American Entomology* (Phila. 3 vols. 1825; new ed. by Leconte, 1859). Of his *American Conchology*, only a few numbers were issued. A list of his scientific articles is given in the *American Journal of Science*, vol. 27.

SAYCE, ARCHIBALD HENRY, English orientalist, was born at Shirehampton, Sept. 25, 1846. He was educated at Grosvenor College, Bath, and Queen's College, Oxford, when he graduated and became fellow in 1869, and tutor in 1870. He took orders but continued his college work, and in 1876 was made deputy professor of comparative philology. He took part in the English revision of the Old Testament, from 1874 till 1884. Besides numerous articles relating to Assyriology and kindred subjects he has published *Principles of Comparative Philology* (1874); *Astronomy and Astrology of the Babylonians* (1874); *Introduction of the Science of Language* (2 vols. 1880); *Monuments of the Hittites* (1881); *Cuneiform Inscriptions of Van* (1882); *Ancient Empires of the East* (1884); *Fresh Light from the Monuments* (1884); *Introduction to Ezra, Nehemiah, and Esther* (1885); *Assyria; its Princes, Priests, and People* (1886).

SCAMMELL, ALEXANDER (1747-1781), colonel in the American Revolutionary army, was born at Mendon, now Milford, Mass., March 24, 1747. He was the son of a physician of English birth, and graduated at Harvard in 1769. He taught school and assisted in surveying for Holland's map of New Hampshire. He had commenced the study of law with John Sullivan, and when the latter was made brigadier-general in 1775, Scammell became his brigade major, and served in the siege of Boston and on Long Island. In 1776 he was made colonel of the Third New Hampshire Regiment, and fought at Trenton, Princeton, and Saratoga, being wounded at the last. He was then made adjutant-general of the army, but in 1781 he resumed service as colonel. At the siege of Yorktown he was surprised while reconnoitering, and after surrendering was wounded so that he died at Williamsburg, Oct. 6, 1781.

SCARLET FEVER. See FEVER.

SCHIAFF, PHILIP, a native of Switzerland, master of German theology, has become a foremost representative of American Protestantism. He was born at Coire, Jan. 1, 1819, and was educated at Stuttgart, and at the Universities of Tübingen, Halle, and Berlin, receiving from the last the degrees of Ph.D. in 1841. During his early college life he travelled extensively on the continent, and in 1842 he began to lecture on theology at Berlin. About that time the German Reformed Church of the United States was seeking to obtain closer contact with the life and thought of the Evangelical Churches of Continental Europe. For this purpose the study of German philosophy and theology was promoted and an effort was made to obtain from Germany a thoroughly trained expounder of those branches. Neander, Hengstenberg, Tholuck, and others, whose advice was asked, concurred in recommending the young lecturer, and he was accordingly called in 1843 to the professorship of church history and exegesis in the Theological Seminary at Mercersburg, Pa. After some months spent in travel on the continent and in Great Britain, he sailed for America and entered on his new work. In the Seminary and in Marshall College, with which it was closely connected, Rev. John W. Nevin, D.D., was the chief director. Prof. Schaff became an efficient coadjutor, teaching in both Seminary and College, and contributing valuable articles to the *Mercersburg Review*, which they started in 1849. His first separate publication was *The Principle of Protestantism* (1845), which had been written in German, and was translated into English, with an

introduction by Dr. Nevin. In opposition to the extreme individualism which had prevailed in the New England Churches, Prof. Schaff insisted on the historic development of the Church, as an organism. His views provoked a controversy even in the German Reformed Church, and he was tried for heresy but acquitted. His *History of the Apostolic Church* (1851), appeared first in German, was soon translated into English, and finally expanded into his valuable *History of the Christian Church* (6 vols., 1859-88). Meantime had appeared his *Life and Labors of St. Augustine* (1853), and numerous essays and articles, by no means confined to theology. In 1854 Prof. Schaff paid a visit to his friends in Europe, and received from his Alma Mater the degree of D. D. He took occasion to publish for the benefit of Germans, *America: The Political, Social, and Religious Condition of the United States* (Berlin, 1854). This was translated into English, and after his return he prepared a somewhat similar book on *Germany: its Universities, Theology and Religion* (1857), giving graphic sketches of its most prominent theologians. Dr. Schaff's mastery of the department of church history was now universally acknowledged. He was a contributor to several theological quarterlies and to other periodicals. In 1862 he was appointed a lecturer in Andover Seminary, and afterwards in other institutions. In 1863 the seminary at Mercersburg having been closed in consequence of the civil war, Dr. Schaff removed to New York city, which has since been his residence. He was secretary of the New York Sabbath Committee from 1863 to 1869, and visited Europe in 1865 to promote Sabbath observance and Sunday schools. After settling in New York, he joined the Presbyterian Church, and in 1870 was chosen professor of apologetics and symbols in the Union Theological Seminary. In 1872 he was transferred to the chair of Hebrew, and in 1875 to that of sacred literature. He was the chief American organizer of the Evangelical Alliance and superintended the arrangements of its meeting in New York city in 1873. He was also a delegate to its conferences at Basle in 1875, and at Copenhagen in 1884. In like manner he took part in forming the Alliance of the Reformed Churches in 1875, and he has been prominent at its meetings at Edinburgh (1877), Philadelphia (1880), Belfast (1884), and London (1888). This Alliance is often called the Presbyterian Alliance.

In 1865 there appeared under Dr. Schaff's editorial supervision the first volume of an American revised and enlarged edition of Dr. J. P. Lange's *Commentary on the Bible*. In this edition twenty prominent American scholars contributed to improve the elaborate original. Such was the value of their labors that this work was accepted in England as the standard translation. The association thus exhibited in Biblical work easily prepared the way for the organization of an American committee to assist in revising the English version of the Bible. This work was commenced in 1871, and successfully and harmoniously completed under the direction of Dr. Schaff, who published an *Introduction on the Revision of the Bible* (1873). The Revised Version of the New Testament was issued simultaneously in May, 1881, in England and America; the Old Testament was similarly issued in 1885.

Another notable work by Dr. Schaff is *The Creeds of Christendom* (3 vols., 1877), being a collection of the authorized symbols and confessions of the principal Christian Churches, with notes and introduction. In his efforts to popularize the latest results of German research, Dr. Schaff became editor of an American edition of the *Religious Encyclopedia*, prepared by Drs. Herzog and Piitt. This was translated, revised, and condensed, while extensive articles pertaining to American topics were added. The whole was published under the title, *The Schaff-*

Herzog Dictionary of Religious Knowledge (3 vols., 1884). A supplemental volume, giving biographical sketches of living divines, has since been issued (1887).

Besides the various works already mentioned, Dr. Schaff has prepared collections of hymns, both German and English; *Christ in Song* (1868), an illustrated *Bible Dictionary* (1880), and with Arthur Gilman, a *Library of Religious Poetry* (1881). In 1886 he became editor of the *Select Library of the Nicene and Post-Nicene Fathers*, to be completed in 25 volumes. In his prodigious literary activity he has been assisted by various helpers, notably Rev. S. M. Jackson, and his son, Rev. D. S. Schaff.

(J. P. L.)

SCHAUFFLER, WILLIAM GOTTLIEB (1798-1883), missionary, was born at Stuttgart, Würtemberg, Aug. 22, 1798, but was taken by his father to Odessa in childhood. In 1826 he was taken by Rev. Joseph Wolff, Constantinople, to be prepared for missionary work. Afterwards he went to America and studied theology at Andover. Being appointed a missionary of the American Board in 1831, he returned to Constantinople and there devoted himself with the utmost diligence to mission work, including the translation of the Bible into the Osmanli-Turkish dialect. He was conversant with nineteen languages, and able to preach in several of them. His scholarship and labors obtained for him degrees from German and American universities. He died at the residence of his son in New York city, Jan. 26, 1883.

SCHIEFFEL, JOSEPH VICTOR VON (1826-1886), German poet, was born in Karlsruhe, Baden, Feb. 16, 1826. He was educated in the Lyceum of that city and afterwards studied science, philology, and literature in Munich, Heidelberg, and Berlin. From 1848 to 1852 he was referendary at Sackingen, and then abandoning the service of the State, spent 1852-53 in Italy. Later, he lived occasionally in Munich and Heidelberg. For a time he was librarian to the Prince of Fürstenberg, at Donaueschingen, and he also enjoyed the patronage of the Grand-Duke Alexander of Weimar. From 1866 till his death in Karlsruhe, April 9, 1886, he lived partly in that city and partly on his estate near Radolfzell on the Lake of Constance.

His first greatly successful epic poem—*The Trumpeter of Sackingen*—had its origin in 1853, in Sorrento, on the island of Capri, where he lived in friendly intercourse with Paul Heyse. His *Poems* (1886), illustrated by A. von Werner, comprise fresh German and Italian genre pictures and cabinet-pieces recalling the humor of Hoffmann. The historical romance *Ekkehard* (Frankfort, 1855; Stuttgart, 1886, illustrated by von Werner), as well as the novel *Juniperus, the History of a Crusader* (Stuttgart, 1833), present vivid pictures of mediæval life. His collection of poems, *Franz Aventiure, Songs of the time of Heinrich von Osterreich*, seems like an echo of the old German minnesingers, while his *Gaudeamus, Songs from far and near*, delight by their genial humor and strike the genuine popular note. Other productions are his *Pergypsa'men; Waldesamkeit*, and *Waltarilich Verdeutsch*. Schieffel was an original poet, not free from mannerism, but of sound judgment and genuine fancy. In 1876 the Grand Duke of Baden made him a hereditary noble.

SCHIEM, ALEXANDER JACOB (1826-1881), encyclopædist, was born in Widenbriek, Westphalia, March 16, 1826. He was educated at the Universities of Bonn and Tübingen, and was ordained in the Roman Catholic Church. Having become a Protestant, he emigrated to the United States in 1851, and was made professor of modern languages in Dickinson College in 1854. Having become a contributor to Appleton's *New American Cyclopædia*

in 1859, he removed to New York, and was there diligently employed in editing and contributing to newspapers and encyclopedias until his death at West Hoboken, N. J., May 21, 1881. From 1874 he had been also assistant superintendent of public schools for New York city, and with Henry Kiddle he edited the *Cyclopaedia of Education* (1877).

SCHENCK, ROBERT CUMMING, general, was born at Franklin, Ohio, Oct. 7, 1809. His father served as an officer in Gen. Harrison's army. He graduated at Miami University in 1827, and became professor there. After being admitted to the bar he settled at Dayton, and was soon elected to the legislature. In 1843 he was elected to Congress as a Whig, and gained reputation for his pungent speeches. In 1851 he was sent as U. S. minister to Brazil. After his return he practised his profession until the outbreak of the civil war, when he was commissioned brigadier-general of volunteers. In June, 1861, while his command were being transported by railroad to Vienna, Va., they were fired upon and sustained severe loss. Gen. Schenck was engaged at Bull Run, and served in West Virginia, and in the Shenandoah Valley. At the second battle of Bull Run, he commanded a division and had his right arm shattered by a rifle ball. He was promoted major-general, Sept. 18, 1862, and appointed to the command of Baltimore, which he protected during Lee's invasion of Pennsylvania. In 1863 he returned to Congress and took a prominent part throughout the reconstruction period. He was latterly chairman of the committee of ways and means. In 1871 he was sent as U. S. minister to England and discharged his diplomatic duties well, but on the failure of a silver-mining company in which he was a director he resigned in 1876, and afterwards practised law at Washington.

SCHENECTADY, a city of New York, county-seat of Schenectady co., is on the south bank of the Mohawk River, 17 miles N. W. of Albany. It is on the N. Y. Central, the Albany and Susquehanna, and the Rensselaer and Saratoga railroads, and on the Erie canal. It is the seat of Union College, now enlarged into Union University by the addition of law and medical schools at Albany. (See UNION UNIVERSITY.) Schenectady has a city hall and court-house, a national bank and other banks, 2 high schools, 20 churches, 2 daily and 4 weekly newspapers. Its industrial works comprise woolen and flour mills, machine and boiler shops, locomotive works, stove foundries, broom factories, and other manufactories. It was an Indian trading post in 1620, and was chartered in 1684. As a frontier settlement, it was a place of interest in the French and Indian War, and in the Revolution. In 1798 it was made a city. In 1880 its population was 13,057.

SCHENKEL, DANIEL (1813-1885), a Swiss theologian, was born at Dägerlen, near Zurich, Dec. 21, 1813. He studied theology at Basel and Göttingen, his instructors being De Wette, Hagenbach, Gieseler, and Lücke. He began to lecture at Basel in 1837, and in 1841 was made pastor at Schaffhausen. Upon the death of De Wette in 1849, Schenkel, who was his closest follower in spirit and method, was chosen to succeed him as professor of theology at Basel, but in 1851 he was called by the grand-duke of Baden to be chief university preacher and church councillor. His noted work, *Das Wesen des Protestantismus* (3 vols. 1846-51), while aiming at a reconciliation of modern rationalist criticism with the spirit of the Reformation, yet marked a wide departure from the orthodox theology and its views of the inspiration of the Scriptures. Schenkel contributed to Lange's *Biblewerk* commentaries on Ephesians, Philippians, and Colossians, but as he swerved more widely from orthodoxy, this place was afterwards supplied by Dr. Braune's commentaries. Schenkel also edited

the *Allgemeine Kirchenzeitung*, and strenuously supported the liberal movement both in theology and in church constitution. He endeavored to introduce the congregational principle into the Hessian Church. Schenkel's free thinking culminated in his *Das Charakterbild Jesu* (1864), which passed through several editions, but against which 118 pastors in Baden published a protest. In reply Schenkel issued *Die protestantische Freiheit in ihrem gegenwärtigen Kampfe mit der kirchlichen Reaktion* (1865). He was one of the most active promoters of the Protestantenverein (for which see ENCYCLOPÆDIA BRITANNICA). This movement he advocated in *Christentum und Kirche in Einklang mit der Kulturentwicklung* (1867) and various other publications. At the approach of the Vatican Council Prof. Schenkel was vigorous in his denunciation of the new pretensions which were proposed to be put forth by the Roman Church and its head. At the great Protestant reunion at Worms Schenkel was the chief orator and his report was adopted by 20,000 adherents. The most important of Schenkel's literary labors was his *Bibel-Lexikon* (1867-75), in which he was aided by a numerous corps of scholars. Among his later works was *Das Christusbild der Apostel und der nachapostelischen Zeit* (1875). He was always an active contributor to periodicals, and he published many pamphlets on theological and polemic subjects. After a long illness he died at Heidelberg, May 20, 1885.

SCHIERER, EDMOND HENRI ADOLPHE, French liberal theologian and journalist, was born at Paris, April 8, 1815. His father was a Swiss by birth and a banker by profession. The son studied at the Collège Bourbon, spent two years in England, and after his return studied law at Paris and theology at Strasburg. He was appointed professor of exegesis at Geneva in 1845, but when his views of the inspiration of the Bible changed, resigned his post and published *La Critique et la Foi* (1850). Then he became a leader of the liberal party in the French Reformed Church. After the overthrow of the Empire he entered into political life and was elected to the national assembly in July, 1871. He was a leader among the republicans and endeavored to promote the union of their various groups. He was active in his efforts against the ministry of the Duc de Broglie and assisted in effecting its overthrow. He was a correspondent of the *London Daily News* and a regular contributor to *Le Temps* until 1879, when he withdrew on personal grounds. He was also connected with Colani's *Revue de Théologie et de Philosophie chrétienne*. From his contribution to periodicals he gathered *Mélanges de Critique religieuse* (1860), which passed through several editions. He also published *Alexandre Vinet* (1853; *Études critiques sur la littérature contemporaine* 5 series, 1863-78); *Mélanges d'histoire religieuse* (1864).

SCHIAPARELLI, GIOVANNI VIRGINIUS, Italian astronomer, was born at Savignano, March 5, 1835. He pursued mathematical studies at Turin until 1856, when he went to Berlin and afterwards to Pulkowa for observatory work. In 1860 he was employed in the observatory at Milan and in 1862 was made director there. His work has given him high rank among living astronomers. He has discovered an asteroid, and has published treatises on comets and various stars, on the planet Mars and some satellites. He has also published an historical work on *The Precursors of Copernicus in Antiquity* (Milan, 1873).

SCHLATTER, MICHAEL. See REFORMED CHURCH IN THE UNITED STATES.

SCHLIEMANN, HEINRICH, archaeological explorer, was born Jan. 6, 1822, at Neu-Buckow in Mecklenburg-Schwerin. His father was a poor clergyman, and the son leaving school at the age

of 14 was apprenticed to a shopkeeper in Fürstenberg. At the end of five years overwork had rendered him useless to his master, and he went to Hamburg. He obtained a place as cabin-boy on a ship bound for Venezuela, but the ship was wrecked on the island Texel, and the unfortunate youth was sent to hospital at Amsterdam. In this city he obtained mercantile employment and diligently improved his leisure in the acquirement of modern languages. After he had learned Russian, his employers sent him to St. Petersburg, where he spent eleven years in business. Having learned Modern Greek, he took up the study of the ancient language and was soon enraptured with Homer. In 1858 he set out on travels which extended through Sweden, Denmark, Germany, Italy, Egypt, Syria, and Greece. In 1863 he resumed his business activity intending to acquire the means of devoting himself to Greek archaeology. In 1864 he set out on a journey around the world which was completed in 1866, and furnished material for his first publication. Two years later he went to Greece and Asia Minor to visit the scenes of Homer's poems. He had married a Greek lady, who had attracted him by her devotion to the same poet, and her sympathy and assistance were of great benefit to his researches. Having come to the conclusion that the site of ancient Troy was at Hisarlik, he determined in 1870 to explore the place. He employed 150 laborers, whose excavations revealed the ruins or traces of no less than six successive settlements. One of these, which had been burnt, he pronounced Homeric Troy. Treasure enough was obtained to repay all the outlay, but the greater part has been deposited in the Schliemann Museum, a part of the Ethnological Museum in Berlin. The publication of his researches provoked great controversy, as classical scholars had generally been adverse to admitting Hisarlik as the site of Troy. But the positive results of his explorations were too great to be gainsaid. In 1876 he undertook the exploration of the site of Mycenæ, and obtained from its tombs an enormous amount of treasure. Again in 1881-82 he excavated the treasury of Orchomenos, and discovered many remains of prehistoric art. Finally in 1884-85 he explored in the same way the site of Tiryns and brought to light the prehistoric palace of its kings. These discoveries were set before the world in a succession of splendid volumes, of which may be mentioned here *Trojanische Alterthümer* (with atlas, 1874); *Mycenæ*, with introduction by Gladstone (1878); *Ilios*, with introduction by R. Virchow (1881); *Orchomenos* (1881); *Troja*, with introduction by A. H. Sayce (1883); *Tiryns*, with introduction by F. Adler and essays by W. Dörpfeld (1886). Most of these issued simultaneously in English, French, and German. Among the marks of honor bestowed on Schliemann were the degree of doctor of philosophy by the University of Rostock in 1869, the degree of doctor of civil law by the University of Oxford in 1883. He has since 1871 resided chiefly at Athens.

SCHMUCKER, SAMUEL SIMON (1799-1873), Lutheran minister, was born Feb. 28, 1799, at Hagerstown, Md., where his father, Rev. John G. Schmucker, D.D., was pastor. He studied theology and in 1820 was ordained pastor of a church at Newmarket, Va. In 1826 he was made president of the theological seminary, then begun at Gettysburg, and held this position until the institution was closed by the civil war. He died July 26, 1873. He contributed to theological reviews and published several works on Lutheranism and other subjects. His son SAMUEL MOSHEIM SMUCKER (1823-1863) became a Lutheran clergyman, then a lawyer and finally a prolific author of popular biographies and similar books. Another son, BEALE MELANCHTHON SCHMUCKER (1827-1888), succeeded to his

father's denominational activity and prominence. He held pastorates at Martinsburg, Va., Allentown, Easton, Reading, and Pottstown, Pa. He was one of the founders of the Lutheran General Council in 1867, and devoted much attention to the liturgy and hymnology of the church.

SCHNAASE, KARL (1798-1875), German art-historian, was born at Dantzic in 1798. After studying philosophy and jurisprudence at the University of Heidelberg, he made a tour in Germany, in the course of which the art-gallery of Dresden awakened his innate love for the fine arts. After having filled several offices in Dantzic and Königsberg, he set out, in 1825, for Italy and there became deeply interested in the study of the architectural *chefs-d'œuvre* of the middle ages and antiquity, the history of which, in after-life, occupied all the hours he could spare from his public administrative functions. He was appointed assessor at Königsberg, 1826, councillor of the superior provincial court of Marienwerder, 1829, councillor of the High Court of Berlin, 1845, from which last office he retired into private life in 1857. Among his numerous works are *Letters from the Netherlands* (Stuttgart, 1834), in which he treats the study of art from a historical and philosophical point of view; the Introduction to the work of Schwantaler, entitled *The Crusade of Frederick Barbarossa* (1840); *History of the Fine Arts* (Düsseldorf, 7 vols., 1843-1864; 2d ed., 1866), the last being his most important work. Beside this he has been one of the most active collaborators on the *German Art Magazine*, and the *Art Magazine* of Tübingen. In 1858 he founded the *Journal of Christian Art*, which he edited for many years in conjunction with Grunzeisen and Schnorr von Carolsfeld. In 1867 he settled in Wiesbaden and died there May 20, 1875.

SCHOFIELD, JOHN MCALLISTER, major-general, was born in Chautauqua co., N. Y., Sept. 29, 1831. He graduated at West Point in 1853 and was professor of natural philosophy there until 1860, when he took a similar position in Washington University, St. Louis. When the secession movement began in Missouri, he was appointed major of the First Missouri Volunteers and was chief of staff to Gen. Nathaniel Lyon until the death of that commander. Schofield was commissioned brigadier-general in November, 1861, and had command in Missouri. He was commissioned major-general of volunteers Nov. 29, 1862, but remained west of the Mississippi until January, 1864. He was then placed in command of the Army of the Ohio, relieving Gen. J. G. Foster who had been holding Knoxville, Tenn. He led the 23d Army Corps in Gen. Sherman's campaign, taking part in most of the fighting until the capture of Atlanta in September. In November he was sent in pursuit of Gen. J. B. Hood, who had left Georgia to invade Tennessee and capture Nashville, which was held by Gen. G. H. Thomas. After some fighting along the road Schofield defeated Hood's army at Franklin, Tenn., Nov. 30, and joined Thomas. For this service he was made brigadier-general in the regular army. After Hood's army was dispersed, Schofield in 1865 was ordered to Annapolis, Md., and thence sent by sea to North Carolina. He occupied Wilmington Feb. 22, fought again at Kingston and joined Gen. Sherman at Goldsboro March 22. When Gen. J. E. Johnston surrendered his command, Gen. Schofield was appointed to carry out the terms of the convention. He had command of the military district of Virginia 1866-67. When the attempted impeachment of President Johnson had failed, in May, 1868, Stanton was obliged to resign his position as Secretary of War, and the President appointed Gen. Schofield Secretary *ad interim*. The position had just been the object of a fierce conflict between the

President and Congress, but Schofield accepted and discharged the dangerous duty in such a masterly way as to offend neither party. He retired when Gen. Grant was inaugurated in 1869 and was promoted to be major-general U. S. A. He was assigned to the department of Missouri, but a year later was transferred to the division of the Pacific. In July, 1876, he was made superintendent of the Military Academy at West Point. In 1882 he was again made commander of the Department of the Pacific with headquarters at San Francisco. After the death of Gen. Hancock Gen. Schofield succeeded in April, 1886, to the command of the division of the Atlantic, with his headquarters at Governor's Island, New York harbor. On the death of Gen. Sheridan he became commander of the United States army in August, 1888, but continued at New York until December, when he removed to Washington.

SCHOLTEN, JOHANNES HENDRIK (1811-1885), Dutch rationalist theologian, was born at Leuten, near Utrecht, Aug. 17, 1811. His father was a minister, and his uncle professor in the University of Utrecht. Scholten after a brilliant academical career in that institution received the degrees of doctor of philosophy and of theology and was for some time a pastor at Meerkerk. In 1843 he was made a professor of theology in the University of Leyden and soon gave a remarkable impulse to historical, critical and dogmatic studies not only in the Netherlands, but throughout Europe. He was rector of the University at various times and finally retired in 1881. Among his works are those on the *Doctrine of the Reformed Church* (2 vols., 1848-50); *Historical and Critical Introduction to the New Testament* (1853); *Comparative History of Religion and Philosophy* (1853); *Free Will critically examined* (1859); *The Gospel of John* (1864); *Supernaturalism in relation to the Bible* (1867); *The Pauline Gospel* (1878); and several critical treatises on the four Gospels. On retiring from his professorship he delivered an address reviewing his theological development. He died in 1885.

SCHOMBURGK, SIR ROBERT HERMANN (1804-1865), German-British explorer and naturalist, was born at Freiburg, Prussia, June 5, 1804. He entered on a mercantile career at Leipsic and afterwards removed to Virginia, where he was partner in a tobacco factory, which failed. He went to the island of St. Thomas, W. I., in 1829, and in the next year made a scientific exploration of Aneгада, one of the Virgin Islands. On the publication of his report of this exploration the Royal Geographical Society commissioned him to explore British Guiana. He spent four years in the work, and among other curiosities discovered the great water-lily which he named "Victoria regia." He published a *Description of British Guiana, Geographical and Statistical* (1840); *The Fishes of Guiana* (3 vols., 1841-3), and other books relating to the country. For his *Report* to the Royal Geographical Society he received its gold medal, and to the German translation of it by his brother Otto, Alexander von Humboldt contributed an introduction. Schomburgk was employed on the survey of the boundary between British Guiana and Brazil until 1844, and was knighted soon after. He was appointed British consul and chargé d'affaires in the Dominican Republic in 1848, and in 1857 was sent to Siam as consul general. He retired in 1864, and died at Schöneberg, near Berlin, March 11, 1865. Besides the works already mentioned he published a *History of the Barbadoes* (1847) and *Discovery of Guiana by Sir Walter Raleigh* (1848).

His brother, Moritz Richard Schomburgk, who had assisted in exploring Guiana, went to Australia in 1849, and was made director of the botanical garden at Adelaide in 1865.

SCHOOLS. See COMMON SCHOOLS and EDUCATION.

SCHULZE, FRANZ EITLAHD, German zoologist, was born at Eldena, near Greifswald, March 22, 1840. He studied at Rostock and at Bonn, where Max Schultze influenced him. In 1865 he was made professor of comparative anatomy at Rostock and took part in a Prussian scientific expedition to the North Sea. In 1873 he was called to Gatz as professor of zoology, and in 1884 to Berlin, where he was made a member of the Royal Academy. His writings relate chiefly to histology and the development of the lower animals. Among his noted essays are *Die Hautsinnesorgane der Fische und Amphibien* and *Codylophora lacustris* and some on sponges.

SCHULZE-DELITZSCH, HERMANN, German economist, was born at Delitzsch, Saxony, Aug. 29, 1808. He was educated at the Universities of Leipsic and Halle and entered on a judicial career. Devoting his leisure to economical studies he became noted by his efforts for the improvement of the working classes. In 1848 he was elected to the National Assembly at Berlin and was made chairman of a committee of inquiry in regard to their needs. He opposed both the old system of guilds and the Socialistic schemes of State organizations. Instead he advocated self-reliant associations of workmen. Eventually his ideas took shape and gained great popularity. In 1851 he founded the first Credit-Union or People's Bank, whose plan closely resembled that of American building associations (q. v.). In 1878 there were in Germany 948 Credit Unions with 480,507 members, while Belgium, France and other countries had many associations of the same kind. Dr. Schulze-Delitzsch has been elected to the Chamber of Deputies at Berlin in 1861, and afterwards to the Reichstag, where he still urged his favorite idea of perfect freedom of association. Among his publications are *Das Associationsbuch* (1862); *Die Arbeitenden Klassen und das Associationswesen* (1863); *Die Vorschuss- und Creditverein als Volksbanken* (1864); *Die Entwicklung des Genossenschaftswesens* (1870), and treatises on political economy.

SCHURZ, CARL, politician and journalist, was born at Liblar, near Cologne, Prussia, March 2, 1829. He was educated at Cologne and at the University of Bonn. Here in 1848 he conducted a liberal journal, and in the following spring was concerned in an attempt at insurrection. Failing in this he became adjutant of a revolutionary army in South Germany, and after the surrender of Rastadt fled to Switzerland. He afterwards assisted Gen. Kinkel, the leader of the revolt in Bonn, in escaping from Spandau. After a year's residence in London, Schurz came to America in 1852, and spent three years in Philadelphia. In 1855 he removed to Madison, Wisc., and there soon became a political leader. He was active in rousing the German element of that State to opposition to the extension of slavery. In 1857 he was candidate for lieutenant-governor of Wisconsin on the Republican ticket, but was defeated. In the famous campaign in which S. A. Douglas and Abraham Lincoln contended for the U. S. Senatorship for Illinois, Schurz delivered his first political speech in English. Thenceforth he was conspicuous as one of the most effective speakers of the Republican party. In the National Convention of that party at Chicago in 1860 he was influential in shaping the platform adopted. Pres. Lincoln sent him as U. S. minister to Spain, but before the close of 1861 he resigned to enter the army. In April, 1862, he was made a brigadier-general of volunteers and in June he took command of a division in Gen. Sigel's corps. He fought in the second battle of Bull Run, and in the battle of Chancellorsville, where his troops were surprised and routed by "Stonewall" Jackson. At Gettys-

burg and at Chattanooga his division retrieved its reputation. After the war Schurz remained in Washington for a time, and in 1865 was sent by Pres. Johnson on a special tour through the Southern States. His report of their condition showed a general acquiescence in the results of the war. Schurz had now entered on a journalistic career, and after establishing a paper at Detroit, went to St. Louis as editor of the *Westliche Post*. His influence with the German-American element of the population seemed unbounded. In 1869 he became U. S. Senator from Missouri, and though he had been an ardent supporter of Gen. Grant as a candidate for the presidency, he soon joined with Senator Sumner in opposing some favorite measures of the President. Among these was the attempt to acquire Santo Domingo for the United States. An alleged sale of arms to the French nation also became the subject of animadversion. In 1872 the opposition to Pres. Grant's renomination resulted in a Liberal Republican Convention at Cincinnati. Horace Greeley was here nominated for the presidency, though the originators of the movement had preferred Charles Francis Adams. Greeley was endorsed by the Democratic Convention, but was completely defeated. Many members of the Liberal party thenceforth remained with the Democrats, but Schurz in 1876 gave his support to the Republican nominee; and Pres. Hayes called Schurz into the Cabinet as Secretary of the Interior. His administration of this office was marked by energy, integrity and a determination to enforce the laws. His treatment of some Indian tribes, however, provoked adverse criticism. After retiring from this office Schurz was connected with the New York *Evening Post* until a change of proprietorship caused his withdrawal. At this time he declined the offer of a pecuniary testimonial from the admirers of his political course. In 1884 he was again conspicuous for his opposition to Mr. Blaine, the presidential nominee of the Republican party, and was a leader of the "Mugwumps." In 1886 a fall in the street caused him severe injury, from which he but slowly recovered. He afterwards went to Europe, where he had cordial meetings with Prince Bismarck and other political leaders of Germany. Besides his political speeches, which have been widely circulated, he published in the series of *American Statesmen* the best biography of *Henry Clay* (1887).

SCHUYLER, PHILIP (1733-1804), general in the American Revolution, was the great grandson of Philip Pieter von Schuyler, who emigrated from Holland and settled at Albany, N. Y., in 1650. Members of his family were prominent in Indian affairs and held various local offices. Philip was born at Albany, Nov. 22, 1733. He inherited from his father and uncle large estates, and his wealth was increased by his marriage with Catharine Van Rensselaer. He was early employed in military affairs; in 1755 he was captain in an expedition to Crown Point; in 1756 he was major and commissary to the expedition to Oswego; in 1758 he had similar duties in the expedition for the invasion of Canada. Before the close of that war he visited England, being captured on the voyage by a French privateer, but released by a British frigate. Afterwards he was a member of the colonial assembly and he took part in the disputes respecting Vermont. When the conflict with Great Britain began Schuyler took the patriotic side. Such was his prominence that in 1775 Congress first appointed him as Gen. Washington's associate in prescribing the regulations for the American army, and a few days later commissioned him as major-general with command of the Northern Department. He set out for the invasion of Canada by way of Lake Champlain, but in September was compelled by ill health to return to

Albany while Montgomery went on to meet his fate at Quebec. Schuyler's withdrawal gave rise to charges against his loyalty, and when Congress sent Gen. Gates to be his associate in command, he offered his resignation, but it was not accepted. Then he demanded a court of inquiry, which was granted. The court approved Schuyler's conduct, but did not advise the removal of Gates. Schuyler then had himself chosen to Congress in 1777, and pleaded his cause in person with such effect that he was restored to full command. He set out from Albany to oppose Burgoyne's invasion, but found that St. Clair had already been forced to abandon the strong fortress of Ticonderoga, and had to return. A fierce clamor now arose against Schuyler, especially from New England, which was now open to attack. Congress, yielding to the pressure, sent Gates to supersede him. But Schuyler, thoroughly acquainted with the country and trusted by its inhabitants, was then using every exertion to prepare suitable defence by rallying the troops and erecting fortifications. His earnest patriotism was still more signally displayed in his giving to his rival the full benefit of his services. He was present at Burgoyne's surrender, which his own wise arrangements had greatly helped to bring about. During the following winter another court of inquiry approved his conduct, but in April, 1779, after he had been elected a member of Congress, he resigned from the army. He aided the public treasury by liberal advances from his private resources. From 1780 to 1784 and again from 1786 to 1790 he was a State Senator. In 1789 the New York legislature elected him to the U. S. Senate for two years, after which he returned to the State Senate. In 1797 he was again elected U. S. Senator, but was unable to serve on account of ill health. He died at Albany, Nov. 18, 1804. Though Gen. Schuyler's military career was marked by various misfortunes, he always had the confidence of Washington. See *Lossing's Life and Times of Philip Schuyler* (1872).

SCHWATKA, FREDERICK, explorer, was born at Galena, Illinois, Sept. 29, 1849. He graduated at West Point in 1871, but soon resigned from the army, studied law and was admitted to the bar in New York in 1875. Still not satisfied with his acquirements he studied medicine and received his degree in 1876. In June, 1878, he sailed to the Arctic regions in command of a Franklin search expedition, and returned in Sept. 1880, having discovered and buried the skeletons of several members of Sir John Franklin's party. In 1884 he explored the great river Ynkon in Alaska.

SCHWEIFURTH, GEORGE AUGUST, German explorer and naturalist, was born at Riga, Sept. 29, 1836. Educated there and at the University of Heidelberg, he devoted himself to the study of botany, and made scientific excursions in Russia, France and Italy. In 1863 he resolved to visit Central Africa by way of Khartoum, and returned thence in 1866 with rich collections of natural history. With the approval of the Berlin Academy, he started again in 1869 with the escort of an ivory trader and the favor of the governor-general of Soudan. He explored the country of the Dinkas, Bongos, Niam-Niam and Moubutto, and discovered the Akkas, a pygmy race. In Dec. 1870, he lost by fire his baggage, instruments and journal, but his collections had been previously transmitted to Europe. He arrived at Suez in Aug. 1871, and was received in Germany with great enthusiasm. In 1873-74 he explored the great oasis in the Libyan desert and was appointed by the Khedive director of the museum of natural history at Cairo. In 1876-78 he explored the country between the Nile and the Red Sea, and in 1881 took part in an exploration of the island of Socotra. He has since been engaged in promoting German colonization in

equatorial Africa. He has published *Im Herzen von Africa* (1870), translated into English under the title *The Heart of Africa*. He also published many botanical treatises before and since his African explorations, and a valuable map of Dr. W. Junker's travels in those regions (1887).

SCHWEINITZ, EDMUND ALEXANDER DE (1825-1887), Moravian bishop, was born at Bethlehem, Pa., in 1825. He was educated in that town and at the University of Berlin. After being ordained to the ministry he settled in Philadelphia as pastor of a church, and also edited the *Moravian*, a weekly paper. He also published *The Moravian Manual* (1859); *The Moravian Episcopate* (1865); a *Life of Zeisberger* (2 vols. 1870), and a *History of the Unitas Fratrum* (1884). In 1870 he was made bishop and president of the Northern Conference of the Moravian Church in America. He died at Bethlehem, Dec. 18, 1887.

His uncle, LEWIS DAVID VON SCHWEINITZ (1780-1834), was also a Moravian minister, but was noted chiefly as a botanist. He was born at Bethlehem, Pa., and received his early education there. In 1798 he went to Germany and while there published a treatise on Lusatian fungi. He returned to America in 1812 and settled as pastor in Salem, N. C. By his indefatigable researches he discovered over 1400 new species of American plants, chiefly fungi. He published catalogues of the fungi of North Carolina (1818), and afterwards of North America (1832). His other publications were botanical monographs. From 1821 he resided at Bethlehem, and died there Feb. 8, 1834.

SCLATER, PHILIP LUTLEY, English ornithologist, was born at Hoddington House, Hants, in 1820. He was educated at Corpus Christi College, Oxford, graduating in 1849, and being made fellow of the college. In 1855 he was called to the bar at Lincoln's Inn. In 1859 he was made secretary of the Zoological Society at London. His numerous articles on ornithology and the distribution of animals have been published in the *Transactions* of that Society, in the *Ibis*, and in the *Natural History Review*, both of which he edited. From 1875 to 1877 he was private secretary to his brother, Right Hon. George Selater-Booth, who was then President of the local government board. Afterwards he was general secretary to the British Association for the Advancement of Science until 1882, when he was made Vice-President of that Association. Among his publications are *Zoological Sketches*, *Catalogue of American Birds*, and *Guide to the Gardens of the Zoological Society of London*.

SCLOPIS, FREDERIGO, COUNT (1798-1878), Italian jurist, was born in Turin, in 1798. He studied law at the university of his native city; took his degree in 1818; and gained distinction by compiling, in 1837, the civil code of the Kingdom of Sardinia, as well as in various departments of jurisprudence. In 1845 he was elected corresponding member, and, in 1869, foreign member of the French Institute. In 1848 he became minister of justice and ecclesiastical affairs, and was president of a commission for framing more liberal press laws. In 1849 he was named Senator, and was president of the Sardinian Senate till 1861, when he became president of the Senate of Italy, which office he held till 1864. In 1868 he was decorated by Victor Emmanuel with the order of the Annunziata, and, in 1872, was appointed by him Italian arbitrator at the Congress of Geneva for the settlement of the Alabama claims (*q. v.*). There he was further honored by being made president of the court, and as a token of its sense of the ability and tact with which he performed the functions of his high office, the American government presented him, in 1874, with a valuable service of silver plate. He was the author of several works, but his principal one is

La Storia della Legislazione Italiana (3 vols., Turin, 1840-57). He died at Turin, March 8, 1878.

SCOTT, THOMAS (1747-1821), English Biblical commentator, was born at Bryneroff, Lincolnshire, Feb. 16, 1747. In his early life he was a farm-laborer, yet in spite of poverty obtained a good education and took orders in the Church of England in 1773. Through the influence of Rev. John Newton, Cowper's friend, he became a Calvinist, as related in his *Force of Truth* (1779). He succeeded Newton as curate of Olney in 1781, but a few years later removed to London, where he was chaplain of a hospital. In 1801 he became vicar of Aston Sandford, and here he died April 16, 1821. His chief work is his *Family Bible with Notes* (5 vols., 1788-92), which has passed through many editions both in England and America. His son edited his *Works* (10 vols., 1825).

SCOTT, WILLIAM ANDERSON (1813-1885), Presbyterian minister, was born at Rock Creek, Tenn., Jan. 31, 1813. He graduated at Cumberland College, Kentucky, in 1833, and studied theology at Princeton. Entering the Presbyterian ministry he was missionary in Louisiana, and afterwards principal of academies in Tennessee. In 1840 he became pastor at Tuscaloosa, Ala., and in 1843 took charge of a church at New Orleans. He went to San Francisco in 1854 to be pastor of Calvary Church, and was conspicuous for his opposition to the Vigilance Committee as afterwards for his support of the Secession movement. In 1858 he was moderator of the Presbyterian General Assembly. In 1861 he went to England, becoming for a time pastor of a church in Birmingham. In 1863 he took charge of a church in New York city, and in 1870 returned to San Francisco. There besides being pastor of St. John's Church he was professor in the Theological Seminary and editor of a religious magazine. He died at San Francisco, Jan. 4, 1885. His publications were volumes of sermons, including *Achan in El Dorado* (1855); *Trade and Letters* (1856); *The Giant Judge* (1858); *The Church in the Army* (1862); *The Christ of the Apostles' Creed* (1867).

SCRANTON, a city of Pennsylvania, county seat of Lackawanna co., is on the Lackawanna river at the mouth of Roaring Brook, 18 miles N. E. of Wilkesbarre. It is an important railroad, coal mining and iron-manufacturing town. Locomotives, steam-boilers, railroad and mining machinery, cars, stoves, wagons and carriages, and edge tools, are produced in large numbers. Scranton has 12 banks, an opera-house, theatre, hospital, a cathedral and 40 churches, academies, and public schools, and a public library. Three daily and 12 weekly newspapers are published here. The town was founded in 1840, taking its name from its founders. It became a city in 1856. It is well built with wide streets and handsome edifices. Its population in 1880 was 45,850, making it the third in rank in Pennsylvania.

SCRIVENER, FREDERICK HENRY AMBROSE, English scholar, was born at Bermoudsey, Sept. 29, 1813. He graduated at Trinity College, Cambridge, in 1835, took orders, and was engaged in teaching. While rector of Falmouth from 1846 until 1861 he also conducted a school there. He was afterwards rector of St. Gerrans, Cornwall, and in 1876 became vicar of Hendon. He was one of the company of revisers of the New Testament from 1870 to 1882. His publications relate chiefly to the Greek *New Testament*; besides valuable editions of this work, they comprise *Plain Introduction to the Criticism of the New Testament* (1861); *Collation of the Codex Sinaiticus* (1863); *Codex Bezae* (1864); *Cambridge Paraphrase Bible* (1873).

SCUDDER, JOHN (1793-1855), missionary, was born at Freehold, N. J., Sept. 13, 1793. He gradu-

ated at Princeton in 1811 and at the College of Physicians and Surgeons, New York, in 1815. After a few years' practice of medicine he was convinced of his duty to carry the Gospel to the heathen, and was licensed in the Reformed (Dutch) Church in 1819. He sailed for India and was ordained there by missionaries of other denominations. At Jaffnapatam he opened a hospital and a college, which were highly successful. In 1836 he removed to Madras to superintend the printing of the Scriptures in Tamil. In 1842 he returned to the United States and spent three years in pressing on American churches the claims of foreign missions. Returning to his labors in the Aroet mission, he wrought with such zeal that his health was injured. He was ordered by his physicians to the Cape of Good Hope, and died at Wynberg, near that cape, Jan. 13, 1855. His *Life* was written by J. B. Waterbury, D.D. (1870).

His seven sons and two daughters all served as missionaries in India. Of them may be noted HENRY MARTYN SCUDDER, who was born at Panditeripo, Ceylon, Feb. 5, 1822, graduated at the University of the City of New York in 1840, and at Union Theological Seminary in 1843. Sent out by the American Board, he labored at Madras, Arcot, Vellore and other places, organizing schools and churches. He also studied and practised medicine and established a dispensary at Arcot. He prepared several religious works in the Tamil, Telegu and other languages. In 1864 he returned to the United States and became pastor of a Presbyterian Church in San Francisco, and in 1871 removed to Brooklyn, where he was pastor of a Congregational Church until 1882, when he removed to Chicago. After five years' pastorate there he resigned to resume missionary work in Japan.

SCUDDER, SAMUEL HUBBARD, naturalist, was born at Boston, April 13, 1837. He graduated at Williams College in 1857 and at Lawrence Scientific School in 1862. He then served as assistant to Prof. Louis Agassiz in the museum of comparative zoology, and in 1864 was made custodian of the Boston Society of natural history, of which he had already been secretary. He devoted himself chiefly to entomology, and has published reports on the insects of New Hampshire and on those collected in several U. S. Government surveys as well as the Canada geological survey. From 1879 to 1885 he was assistant librarian of Harvard University, and in 1886 he was appointed paleontologist of the U. S. Geological Surveys. Among his publications are *Fossil Butterflies* (1875); *Catalogue of Scientific Serials of all Countries, 1633-1876* (1879); *Butterflies* (1882); *Nomenclator Zoologicus* (1882); *Winnipeg Country* (1886), the last being a sketch of his adventures with a solar eclipse expedition in Manitoba.

His brother, HORACE ELISHA SCUDDER, author, was born Oct. 16, 1838. He graduated at Williams College in 1858 and for a few years engaged in teaching in New York city. His stories for children, *Seven Little People and their Friends* (1862), having proved highly successful, he removed to Boston and devoted himself to literature. He edited the *Riverside Magazine* from 1867 to 1870, the series of "American Commonwealths" and collections of American prose and poetry. Among his most successful books for children are *The Bodley Books* (8 vols. 1875-87); *Dwellers in Fire Sisters Court* (1876); *Children's Book* (1881). He contributed *Noah Webster* (1882) to the series of "American Men of Letters," and published a *History of the United States* (1884). Among his other works are a biography of his brother, David Coit Scudder (1864), who had been a missionary in India.

SCULPTURE IN AMERICA. The feeling for form, as evinced in sculpture, is naturally one of the first directions in which the art-instinct of a

nation first finds expression. In this country the opposite may almost be said to be the case. America had produced a number of respectable portrait and figure painters, and a few who possessed real genius, before the plastic art became a recognized phase of our art-development.

The art of sculpture can hardly have said to have existed here before the Revolution, if we except the efforts of Deacon Shem Drowne, who executed some quite elaborate weather-vanes, and Patience WRIGHT, whose clever miniature heads in relief, modeled in wax, gained her considerable repute.

One of the first to show the latent capacity of our art in this direction was William RUSH (1756-1833), an artist of undoubtedly great talent. He first became known as a carver of figure-heads for ships, in which line he produced much excellent work. His works are all in wood or clay, which latter material he began to use in 1789. Various ideal figures and portrait busts of Linnæus, William Bartram, Lafayette, and others are among his works, which show much originality and realistic strength. His statue of Washington is in Independence Hall, Philadelphia.

Shortly after Rush had begun work, several foreign sculptors visited America. John Dixey, an Irishman, who came over in 1789, produced several ideal works, among them Hercules and Hydra, Ganymede, etc. Giuseppe Ceracchi, a Corsican, visited Philadelphia in 1791, and executed busts of Washington, Alexander Hamilton, and other prominent Americans. Having returned to Paris, he was detected in a plot against Napoleon, and was guillotined in 1801. Jean Antoine Houdon (1740-1828) came over in 1785 to execute the statue of Washington which now stands in the capitol at Richmond. His cast of the head of Washington has proven extremely useful to many of our native sculptors of a later date. Washington has always been a popular subject with our artists, and just as most of the portrait-painters of his time tried to obtain sittings from him, so nearly every one of our sculptors of portrait-statues has, at some period of his career, produced his statue of the great American.

As late as 1816, Trumbull told Frazee, who applied to him for assistance in studying sculpture, that it would not be wanted here for a century. Yet even there were signs of the awakening of a taste and talent for this branch of art. The before-mentioned John FRAZEE (1790-1850), a stone-cutter, produced a number of portrait busts.—John Wells, said to be the first portrait in marble from a native hand, John Marshall, Daniel Webster, Andrew Jackson, John Jay, and others. With almost no art-education, and but few opportunities for developing his undoubted ability, he yet showed in his works much feeling for the ideal and a power that might have produced greater results under more favorable circumstances. His contemporary, HEZEKIAH AUGUN (1791-1858), is also one of those artists, frequently met with in the history of this country's art, who began their careers in trades and occupations quite different from the art to which they later devoted their lives. As one critic has observed, his work is less notable for its intrinsic value than as an evidence of what may be accomplished by untrained talent, with no educational advantages.

The first ten or fifteen years of this century witnessed the birth of some of the most noted of our earlier sculptors, among whom Powers and Crawford held a commanding position.

Hiram POWERS (1805-73), born in Vermont, early emigrated with his family to the West, settling in Cincinnati. After following various occupations for a while, he found opportunity first to exercise his talent for modeling in executing wax figures for a

museum. Subsequently a German artist taught him the art of modeling in plaster. Aided by Mr. Nicholas Longworth, who showed so much liberality towards our artists, he soon found ample employment in modeling the features of many prominent public individuals, notably Andrew Jackson, Webster, Calhoun, Chief-Justice Marshall and Edward Everett. In 1837 he went to Italy, where he remained until his death. During his long career he executed a number of well-finished and meritorious ideal works, in which he showed much sentiment and considerable technical skill. His statue of the Greek Slave, of which a duplicate was exhibited in the United States, aroused much enthusiasm. Many have praised it for its pure and noble sentiment, and as representing a high type of beauty. Of the adverse criticism that by Jarves in his *Art Idea* is especially severe. Six copies in marble were made of the Greek Slave as well as innumerable reduced copies in parian, casts, etc. The Eve before the Fall and Eve after the Fall are considered by some his best ideal statues, and *Il Penseroso*, Fisher Boy, Proserpine and California are also among his more important works. Though perhaps best known to the general public by these ideal works, notably the Greek Slave, he seems, however, to have achieved his greatest success in portraiture, and his portrait busts are excellent in the portrayal of character and in execution. His mechanical talent enabled him to invent various appliances for facilitating the labors of the sculptor's art.

Thomas CRAWFORD (1814-57) was a man cast in a large mould. There is something grand and earnest in all of his works, and his versatility, enthusiasm and untiring industry were quite remarkable. His first studies were made under Frazee and Launitz, and in 1834 he went to Italy, where he entered the studio of Thorwaldsen. Of his works best known to the public, the majestic and spirited equestrian statue of Washington, at Richmond, and the statue of Beethoven are the most important. Both were cast in Munich, where they attracted much attention. The works ordered by the United States government are also important. They include the panels for the bronze door of the Capitol at Washington, illustrating the American Revolution, the fine statue of Liberty surmounting the dome of the Capitol, and a marble pediment, with symbolical figures delineating the progress of American civilization. The Orpheus and Cerberus, his first ideal group, executed in 1839, is considered by some the work in which his power and ability are best shown. Another well-known statue by him, the Indian Chief, won the admiration especially of the sculptor Gibson.

Another sculptor of this period who must be reckoned among the first of our artists, is Horatio GREENOUGH (1805-52). He was a man of fine intellectual attainments and had, in fact, like several of our prominent artists of the time, a decided literary vein in his composition. His Chanting Cherubs, ordered by J. Fenimore Cooper, was, according to Tuckerman, the first group in marble executed by an American. He is best known by the Bunker Hill Monument, which he designed, and the statue of Washington at the National Capitol. The latter has been the subject of much criticism and ridicule. Its nudity has been objected to as incongruous, and in condemning him for imitating the antique, comparisons have been drawn between this work and Benjamin West's Death of General Wolfe. Yet the statue is withal a noble piece of work. Besides, it must be remembered that Greenough intended it to be placed indoors, in which case the half nude figure would have seemed less incongruous, and gained considerably in impressiveness.

Joel T. HART (1810-77) was a Kentuckian who

first earned a livelihood by chimney-building and later in a stone-cutter's yard. He began to model in clay, and his likenesses soon attracted attention; thereafter, his services were frequently in requisition. Among his portrait busts are those of Jackson, Taylor, and Governor Crittenden, all characteristic and truthful likenesses. It has been said that in some of them the look of flesh is remarkable. His statue of Clay is in Louisville, Ky. In ideal works, like Angelina and the graceful Woman Triumphant, he shows a delicate, refined fancy.

Another, who, like not a few of our earlier sculptors, began his career as a stone-cutter, was Shobal Vail CLEVINGER (1812-43). The success which he had in some of his artistic efforts encouraged him to attempt portraiture. He soon left Cincinnati, where he was working, for the East, and found ample employment in modeling busts of numerous prominent men, among them Clay, Everett, Webster, Allston, Van Buren. In these he gave us a valuable series of remarkably truthful and realistic portraits.

Henry K. BROWN (1814-86) was at first determined to become a portrait-painter, but his attention having been drawn to sculpture he adopted that as a profession. To the general public he will always be known as the sculptor of the equestrian statues of General Scott, at the National Capitol, and Washington in New York. The latter, though open to criticism, is, on the whole, good technically, the horse spirited and graceful, and the general effect grand and noble. It is, moreover, the first statue in bronze wholly made in America.

Some writers have, perhaps with justice, pointed to the works of Clark MILLS (1815-83), as the result, in a measure, of the complete ignorance in art-matters so frequently displayed by the people. His statue of Gen. Jackson, in Washington, is notable especially for the dexterity with which the sculptor has succeeded in so balancing the prancing charger that it needs no support but its own weight. His ability is unquestioned, but he shows in his works rather dexterity and skill, than true genius or a higher art-feeling.

In Benjamin PAUL AKERS (1825-61) we find one of the most gifted of our sculptors. His art-instinct was awakened at an early age, and he attempted painting. But this failed to satisfy him, and it was the sight of a plaster cast that first revealed to him his true vocation. He unfortunately died too young for a complete unfolding of his talents or the production of works that would have been rather fitted to perpetuate his memory than simply to give promise of greater success to come. But in his last statues, like that of the Pearl Diver, an exquisitely beautiful creation, his strong imaginative faculty, his tender, sympathetic, and strongly æsthetic nature as well as his thorough knowledge of the principles of art, are revealed to us. We find in him, again, that taste for literary pursuits, referred to previously as not uncommon among our earlier artists.

A sculptor of rare natural talent was Edward S. BARTHOLOMEW (1822-58). His early life, owing to his unencouraged love for art, was a struggle with adversity. Like Akers he tried his hand first at painting, but having discovered that he was totally color-blind, he turned his attention to sculpture. He produced a number of classic and scriptural subjects, in which he showed much fancy and inventive power. It has been said of him (Tuckerman quotes the remark), that his most prevalent talent was "an intuitive perception of the strongest and most statuesque aspect of a theme." A large number of his works are in the Wadsworth Gallery, Hartford, Conn.

Thomas BALL (b 1819) also turned his attention first to painting, attaining some pro-

ficiency in portraiture. About 1852 he took up modeling. He has produced a number of portrait busts and several statues. That of Webster, in New York, and the equestrian statue of Washington, in Boston, are perhaps his noblest works. Other sculptors there are of this period, whom limited space prevents us from giving more than passing notice. Among these are Henry Dexter (1806-76), specially successful in his portrait busts; Richard S. Greenough (b. 1819), a brother of Horatio, and whose best-known work is the statue of Franklin, in Boston, and Ball Hughes (1806-68). Leonard W. Volk (b. 1828), best known, perhaps, by his monument to Stephen A. Douglas, in Chicago; Charles Calverley (b. 1833); Moses Jacob Ezekiel (b. 1844), who made the group of Religious Liberty, in Fairmount Park, Philadelphia, and has won many honors abroad; C. B. Ives; Barbee; J. W. A. Macdonald (b. 1824); James H. Hazeltine (b. 1833), and Edward V. Valentine (b. 1828), who has executed many statues of Confederate heroes. Valentine's Lee Recumbent is in the Mausoleum of Washington and Lee University, Lexington, Va.

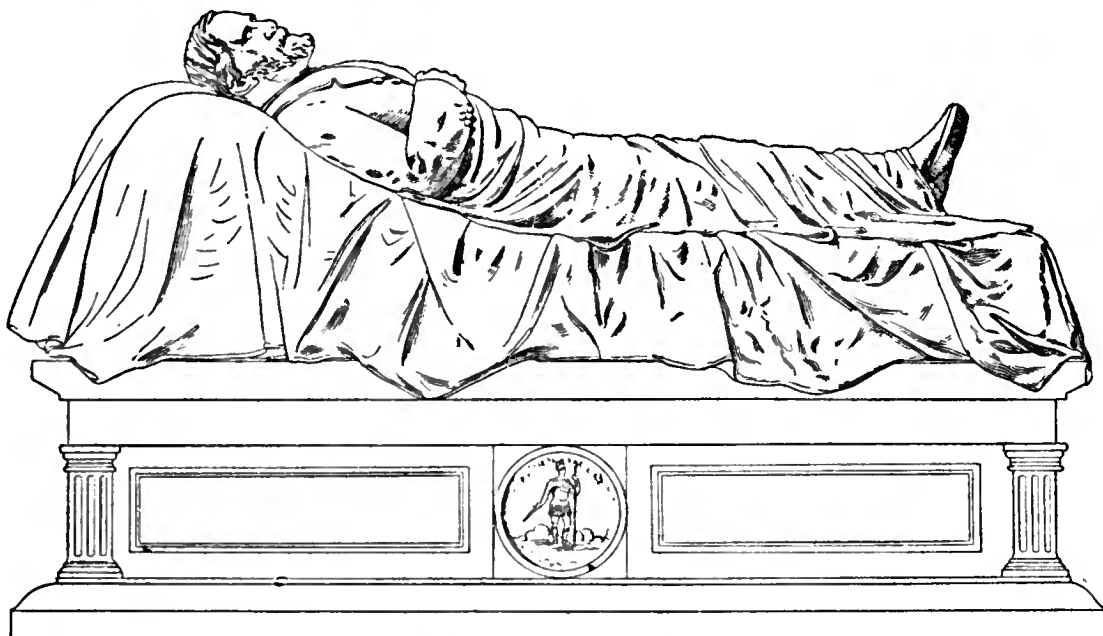

VALENTINE'S "LEE RECUMBENT."

William Wetmore STORY (b. 1819) possesses to a high degree that delicate and noble sentiment, without very great power, which characterizes the works of not a few of our sculptors. His versatility is quite remarkable. Originally a practising lawyer, he published several legal works. Poetry next claimed his attention, and he finally went to Italy to devote himself to sculpture, still, however, occasionally exercising his pen. He holds a prominent position in art, although he has at times been rather indiscriminately praised. His sculpture is not strikingly original, but it is carefully finished, well thought out, severe and classic, and inspired by noble and elevating sentiments. In works like Jerusalem Lamenting, Cleopatra, and the Sibyl, his talents are conspicuously shown.

One of the most truly idealistic sculptors we have had is William H. RINEHART (1825-74). Working at first in a stone-quarry, his evident talent soon attracted attention, and in 1855 he went to Italy to continue his studies. Latona and her Infants, the Sleeping Babes, a Nymph, and Clytie, which he himself pronounced his masterpiece, are among his works. He also completed the bronze doors of the Capitol at Washington, left unfinished by Crawford at his death. Another unfinished work by Crawford, the Washington monument, at Richmond, was completed by Randolph ROGERS (b. 1825). Besides Ruth and various ideal figures Rogers has executed statues of Lincoln for Philadelphia and Seward for New York, and is favorably known by the eight panels for the bronze doors of the Capitol at Washington, delineating scenes in the life of Columbus. Larkin G. MEAD (b. 1835) first gave evidence

of his talents by modeling a figure of an angel in snow. He speedily won recognition, and has executed several public monuments, among them



RANDOLPH ROGERS' "RUTH."

a statue of Lincoln for the monument in Springfield, Ill. Martin MILMORE (1844-83), like Volk, executed several very creditable monuments erected to the soldiers and sailors of the Civil War, notably that in Boston. The subjects of monuments of this class have probably much to do with the fact that they are seldom works of art of a very high order. Franklin SIMMONS (b. 1842) has shown talent and

true art-feeling in statues like those of Roger Williams and Longfellow. The Ghost in Hamlet, the West Wind, and similar works, by Thomas R. GOULD (1818-81), show fancy and ideal feeling rather than technical knowledge.

Originally a carpenter, Erastus D. PALMER (b. 1817) did not turn his attention to art until his 29th year. Beginning as a cutter of cameo portraits, he soon sought a broader field for his talents, and in 1850 exhibited his first piece of sculpture, the Infant Ceres. Like Rinchart, he was a true idealist, with a clear perception of the beautiful. There is, moreover, a vein of domestic sentiment, and a depth of religious feeling shown in many of his productions. His more notable works include The Indian Captive, representing the dawn of Christianity on the savage mind; the purely beautiful White Slave; Spring; The Angel of the Sepulchre, and the exquisite bas-reliefs Morning and Evening. It is a fact worthy of note that, unlike most of our sculptors, he did not acquire his knowledge of art and its technique abroad, but in his native land.

Some of the finest of the statues that adorn our public places are the work of J. Q. A. WARD (b. 1830), one of the most vigorous and original of our sculptors. His work is thoroughly national in subject and spirit, for he has never been unduly influenced by foreign models. Of his portrait statues the most successful are those of Gen. Thomas (one of the best of our equestrian statues), and Washington (at Newburyport). The latter, a noble and majestic work, is a notable addition to the very limited number of really commendable statues of Washington which we possess. Several of Ward's best works are in New York, among them the noble statue of Shakespeare, and the Indian Hunter, one



WARD'S "INDIAN HUNTER."

of his earlier productions, which, though its entire anatomical correctness has been questioned, is yet a characteristic and spirited piece of work, and one of the most notable examples of American plastic art.

Another sculptor whose work ranks with the best produced in this country is LAURENCE THOMPSON (b. 1833), a pupil of Palmer. He early developed an extraordinary talent for medallion portraits, and became one of the strongest and most successful of our portrait sculptors. In works like the bust of Edwin Booth, the statue of Gen. Sedgwick, that of Napoleon, the well-known and excellent one of President Pierson, at Yale, and the equestrian statue of Gen. Burnside, he has shown a talent for

portraiture equalled by few of our sculptors. Dr. WILLIAM RIMMER (1816-79), whose life was devoted mainly to teaching, exerted a decided influence on the art of our younger sculptors. He was a most profound student of art anatomy, on which subject he published a valuable work. He modeled several energetic works, of which the Gladiator, especially, is remarkable for the thorough knowledge of the human figure which it betrays.

In JOHN ROGERS (b. 1829) we find an artist whose work is quite unconventional. He has chosen most of his subjects from the every-day life around him, and in delineating its humorous and pathetic aspects he is quite unrivalled. In illustrating incidents of military life—the life of the common soldier—he first struck a sympathetic chord. There may be no "high art" in his groups, but they appeal to popular feeling and have undoubtedly had a considerable share in elevating the artistic tastes of the people.

The number of women who have turned their attention to sculpture has always been limited, but there are a few American ladies who have gained a certain reputation in this branch of art. The most prominent, HARRIET HOSMER (b. 1830), went to Italy in 1852 to study under Gibson. Although her works are perhaps not all satisfactory from an artistic point of view, yet in statues like Puck, the Sleeping Faun, and the colossal and majestic Zenobia, she has been very successful, and all her works bear the stamp of a strong and decided individuality. EMMA STEBENS (1815-82), the friend and biographer of Charlotte Cushman, produced, among other works, a statue of Horace Mann for Boston, and a large fountain for Central Park, New York. Miss ANNE WHITNEY also gained distinction as an earnest and thoughtful artist. Others who have gained repute in this branch of art are Mrs. H. A. L. FREEMAN, wife of the artist James E. Freeman, Vinnie Ream Hoxie and Edmonia Lewis.

In reviewing the work thus far accomplished in American sculpture, we find that, as in painting, there has been much that is merely imitative. We have seen much "classic" work, which, though often inspired by pure and noble sentiments, and at times executed with considerable technical ability, yet naturally lacked the spirit which pervades the sculpture of antiquity. As in painting, so here some of the best efforts of the earlier artists were exerted in portraiture.

The ignorance in art-matters frequently shown by those who made it their business to select artists for the many national monuments that have already been executed here, has resulted in producing not a few monstrosities that should never have been erected to disfigure our public places. Still, our few really able sculptors have produced some works of lasting merit.

To continue the comparison with painting, the new, progressive movement that has taken place there is also strongly felt here. There have arisen a number of younger sculptors all more or less in sympathy with the strongly realistic tendencies of this new movement. Though much of their work is yet immature and not wholly satisfactory, yet some of them have already attained lasting fame. One of the most prominent is Augustus ST. GAUDENS, who received his technical training under Joubroy in Paris. He has executed a very beautiful bas-relief, the Adoration of the Cross by Angels, in St. Thomas' Church, N. Y., and in his statues of Pres. Lincoln (see p. 459), Admiral Farragut and Robert R. Randall, and the bust of Gen. Wm. T. Sherman, we have excellent examples of powerful, realistic and unconventional style in portrait sculpture. Wm. R. O'DONOVAN has also been very successful in his portrait busts, among which is the masterly one of William Page. The monument to the captors of

André, at Tarrytown, and the statue of Washington, for the Newburg monument, are also his works. Frank DENGLER; Daniel C. FRENCH,



ST. GAUDENS' "ABRAHAM LINCOLN."

sculptor of the Minute Man, at Concord, and the statues of John Harvard and Lewis Cass; Howard ROBERTS, known best by the exceedingly bold and striking statues of Lot's Wife and Hypatia; J. S. HARTLEY, at one time professor at the Art Students' League, and Olin L. WARNER, are among the other important representatives of the new school.

The work of these young men, though, as said before, not by any means entirely faultless, gives promise of a bright future for the plastic art in this country. (F. L. W.)

SEABURY, SAMUEL (1729-1796), first bishop of the Episcopal Church in America, was born at Groton, Conn., Nov. 30, 1729. He graduated at Yale in 1748, and studied theology under his father, then rector at Hempstead, L. I. After taking a year's medical course at the University of Edinburgh, he was ordained deacon by the Bishop of Lincoln Dec. 21, 1753, and priest two days after by the Bishop of Carlisle in London. Returning home, he did missionary work at New Brunswick, N. J., 1754-56, was rector at Jamaica, L. I., 1757-67, and then at Westchester, N. Y. As was the case with most of the Episcopal clergy at that time his sympathies were with the royalists: he became obnoxious to the Whigs through his "Farmer's Letters" reflecting on the Continental Congress, Nov. and Dec. 1774. Withdrawing to New York city, he practised medicine for a time and acted as chaplain of the King's American regiment, 1778. Oxford gave him the degree of D.D., 15 Dec. 1777. The Episcopal ministers of Connecticut, in session at Woodbury on March 25, 1783, elected him bishop; but grave difficulties stood in the way of his consecration. The English bishops feared to act without the consent of Parliament, which could not be procured in the case of a foreigner who could not take the oath of allegiance prescribed by law. After long delay he applied to the Scottish bishops, who were not state officials, and was privately consecrated by three of them at Aberdeen, Nov. 14, 1784, thus procuring the succession for America. Drs. White, Provoost and Madison having afterward been consecrated in England, he joined them in consecrating Dr. Claggett, who thus represented both the Anglican and

Scottish lines, and in organizing the American Episcopal Church in the General Convention of 1789. Seabury was an active and efficient prelate, much respected for his character and talents. Two volumes of his sermons were published 1791 (again 1793 and 1815), and a third volume 1798. He died at his home in New London Feb. 25, 1796. Rev. E. E. Beardsley, D.D., published his *Life and Correspondence* (1881).

SEALSFIELD, CHARLES, was the assumed name of KARL POSTEL (1793-1864), whose true history was not revealed till after his death. He was born at Poppitz, Moravia, March 3, 1793, and after being educated at Znaim, entered the convent of the Knights of the Cross, and was ordained a priest. His unruly spirit and lively imagination brought him into trouble, and in 1822 he escaped from the convent and found refuge in Switzerland. Under his assumed name, he soon emigrated to the United States and was employed on newspapers in New York city. In 1826 he visited Germany and England, publishing in the former a description of America and in the latter *Austria as it is* (1828), which was translated into several languages. In 1827 he returned to the United States and after extensive journeys in the Southwest and Mexico, bought a plantation in Louisiana. But the failure of his banker ruined his prospects and he returned to the North. He then published at Philadelphia a novel, *Tokah, or the White Rose* (1828), which he afterwards enlarged in a German edition, *Der Legitime und der Republicaner* (3 vols., 1833). Meantime he had been employed in journalism at London and Paris and settled in Switzerland, where he is said to have had intimate relations with Queen Hortense. His American experiences furnished him with material for many books, which were mostly written in German, but soon translated into French and English. Among these were *Transatlantic Travelling Sketches* (1834); *The Cabin Book, or Sketches of Life in Texas* (1835); *The Viceroys and the Aristocrats, or Mexico in 1812* (2 vols. 1835), which is his best work; *Pictures of Life in both Hemispheres* (2 vols. 1837); *North and South* (1848); and *Morton, or the Grand Tour* (1846). A collection of his works in German comprising 18 volumes was published at Stuttgart in 1846. He visited America again in 1850 and 1859. His plantation in Louisiana had then become very valuable, but the war interrupted his returns from it. His last years were spent in Solure, Switzerland, where he lived like a peasant, yet remained a mystery to his peasant neighbors until his death March 26, 1864. After his history was revealed by a clergyman of Zurich, a monument was erected to his memory in Poppitz in 1875. His story has been told by Kertbény in *Erinnerungen an Sealsfield* (1864).

SEARCHII, RIGHT OF. The controversy as to the right of maritime visitation and search between the United States and Great Britain was the natural outcome of the change of relationship that they underwent as a consequence of the war of the Revolution. Long after the colonies had asserted their independence of that power Great Britain claimed that their citizens were her subjects and liable to such demands as she might make upon their property or personal services. The treaty of peace of 1783 changed this relation, but left Great Britain disinclined to yield to the Americans anything that could possibly be claimed in virtue of international rights. On the other hand it was to be expected that the United States would take that view of international obligation that would give the largest freedom from intrusions upon her commerce by the powerful navy of her rival, who had been foiled in the effort to make a monopoly of the commerce of America.

The maritime police of the high seas was internationally recognized as in the navies of the respective powers, but the power that maintained the largest naval force necessarily had a preponderating influence in that important administration, and naturally was inclined to enhance the measure of authority due to that function. The terms upon which the cruisers of the various nations could inquire into the national character of vessels upon the seas, so as to suppress piracy, were not in dispute. It was conceded that during war the cruisers of the belligerents could visit and search the vessels of neutral powers for the property of any enemy or for contraband of war, and for the purpose of rendering blockades effectual, provided this power was exercised in a reasonable manner and no demand was made except of passive submission to the exercise of such right, but the existence of such a right in time of peace was strenuously denied by the powers at large and reluctantly yielded by Great Britain.

In the relations between the United States and Great Britain an exceptional use of the power of visitation and search was claimed as a right in one case and insisted upon as a concession in another. Great Britain claimed the right to search American ships for the purpose of taking from them the subjects either claimed as deserters from her marine or needed for that service, and with a view to impressment for that purpose. At a later time Great Britain pressed the recognition of a right of search, encroaching upon the principles of international law, for the purpose of suppressing the African slave trade.

As it regarded the right claimed over American vessels with a view to furnish the British navy with seamen, the United States stoutly resisted the claims of Great Britain as not covered by international recognition and as an encroachment upon the sovereignty of the United States, that was not to be tolerated, and was particularly liable to abuse in view of the close relations between the people of the two countries and their habits of national and local interchange. The United States claimed that the right of visitation and search was merely a belligerent right that could exist only as an incident of war; they also claimed that even as a belligerent right it could not be exercised against a neutral vessel as an assertion of proprietorship over her cargo in behalf of a belligerent or her subjects, as that would be the exercise of a sovereign function under the flag of another sovereign. Much less could that belligerent right be made to cover the exercise of authority over persons under the protection of the sovereign under whose flag they were.

Great Britain relied upon the strength of her navy rather than upon the established usages of nations, and persisted in a course that ultimately brought on war between the two countries. During the Napoleonic wars in 1807 it was charged that British seamen, deserters from her naval service, were harbored at Norfolk, Va. Some British vessels of war were in that vicinity. The American frigate Chesapeake was at this port fitting for sea. She at length sailed, but the British man-of-war Leopard preceded her and arrested her progress, demanding the right to search her for British deserters. This demand being refused, the British ship opened fire upon the Chesapeake and the latter, not being prepared for such unexpected an attack, hauled down her colors. Search was made and several persons were taken from the Chesapeake as deserters and carried away by the Leopard, which now asserted against the Chesapeake none of the rights of the capture.

Congress and the country at large were incensed at this flagrant violation of sovereign right. Congress placed an embargo on trade with Great Britain

as a consequence of this act. A British commissioner sent to this country in the latter part of the same year to treat in regard to the affair of the Chesapeake, was disposed to negotiate as it regarded the question of the right to make search in national vessels for deserters. The United States were unwilling to discuss that question apart from the general question of the right to search merchant vessels, and nothing came of the attempt to negotiate. The Embargo law was repealed upon the accession of Mr. Madison to the Presidency, and a non-intercourse law substituted in its place. Aggressions having in the meantime been made by France on American commerce both England and France were included in this non-intercourse act, their armed vessels being excluded from the ports of the United States, until the violations of neutral rights by those nations should cease. The exclusion of armed vessels was soon revoked as against France upon assurances that the objectionable Milan decree would be revoked, but was continued against Great Britain. British ships were stationed upon the American coast that searched all American vessels and made captures.

In 1811 Congress made military preparations in view of the anticipated hostilities with Great Britain and declared war against her. The hostilities that ensued exhibited, in June, 1812, both in their character and duration, the absence from the policy of Great Britain that led to them of any principle worthy of being vindicated by war. (See WAR OF 1812.) The war was terminated in 1814 by the treaty of Ghent. The remarkable feature of this treaty is that it did not adjust in terms the matter of difference between the two countries, although in effect it produced that result. Since that time Great Britain has made no assertion against the United States of any right to search American vessels for deserters from her navy.

The international efforts to suppress the African slave trade reopened the subject of visitation and search in its application to the detection of slave ships, but the differences that existed between the two countries as to the limit of that right were confined within the limits of negotiation. Great Britain urged the necessity of treaty provisions that would open to search by the national vessels of each country the merchant vessels of the respective countries. The United States, while sympathizing with the object of the effort to suppress the slave trade, were unwilling to create a precedent that might lead to complications tending to impair their maritime interests.

After a prolonged effort to arrive at some mode of exercising maritime police for the purpose of suppressing the African slave trade a treaty was concluded with Great Britain in 1862, by which a limited and regulated right was conferred by each nation upon the armed vessels of the other to examine its merchant vessels when reasonable ground existed for a suspicion that they were engaged in, or fitted for the slave trade. This right was only to be exercised by vessels of war duly authorized for that particular service and carrying instructions that formed part of the treaty, and was to be exercised against merchant vessels only. The right of visitation was to be exercised only within 200 miles of the coast of Africa, south of 32° N. lat., and within 30 leagues of Cuba. It was required that when a vessel should be visited, the instructions carried by the visiting ship should be exhibited, and a certificate of the fact and ground of search given to the commander of the vessel visited, stating the vessel making the search, and the name and rank of its commander.

Mixed courts were established in the United States and at points within the jurisdiction of Great Britain, on the African coast, in which both

nations participated for the trial of cases arising under the treaty, and the vessels of each country subjected to detention were to be sent to the tribunal of the country to which they belonged for trial. The features of the outfit of a vessel that should be regarded as indicating an intention that she should be employed in the slave trade were carefully detailed in the treaty. Provision was made for awarding damages where the detention was not justified by the treaty, and also for the liberation of negroes found in condemned vessels.

In the next year, 1863, this right of search was territorially extended. In 1870, by treaty, the mixed courts were abolished, and the proper courts of the respective nations substituted therefor, American vessels to be sent to American courts and British vessels to British courts.

The right of search thus organized between the United States and Great Britain as it regarded the slave trade was assimilated to that which exists under international recognition in the case of piracy, but subject to specific regulations that have been described. This treatment of the subject is expressive of a close relation between the two classes of cases as depending upon the same principles.

The honorable career thus begun by the United States, in the interest of the liberties of commerce, has in later years developed an effort to place a more clear and just interpretation upon neutral rights in which effort she has happily been brought into relations to Great Britain more becoming nations advanced in civilization than those which were the subject of past differences between them.

(A. J. W.)

SEARS, BARNAS (1802-1880), educator, was the son of Paul and Rachel (Granger) Sears, and was born at Sandisfield, Mass., Nov. 19, 1802. His earlier education was received in his native town, and his immediate preparation for college at the University Grammar School in Providence, R. I. He graduated at Brown University in 1825, and then became a student in the Theological Institution at Newton Centre, Mass. In 1827 he was ordained pastor of the first Baptist Church of Hartford, Conn. This pastorate lasted only two years, as in 1829 he was chosen a professor in the Literary and Theological Institution at Hamilton, N. Y., now known as Madison University. This professorship he held for four years, resigning and going to Germany in 1833, where he remained nearly three years engaged in the earnest prosecution of various studies, chiefly historical, philosophical and theological, at several noted German Universities. In 1836, on his return from Germany, he was elected professor of ecclesiastical history in the Newton Theological Institution, and in 1839 he was made professor of Christian Theology and president of the Institution. When he became professor at Newton the number of men in the colleges and theological schools who could make intelligent and effective use of German learning and criticism was by no means large. Becoming editor of the *Christian Review* in 1838, his free use of what his long stay in Germany had made available, speedily gave to that Quarterly its distinctive characteristics among the Quarterlies of the country. Abandoning this editorship in 1841, he afterwards, when the *Bibliotheca Sacra* was started, continued for many years to use his knowledge of German as a contributor to its pages. In 1848, after twelve years of distinguished service, he resigned his position at the Newton Theological Institution to become the successor of Horace Mann as secretary of the Massachusetts Board of Education. Mr. Mann had accomplished a great work in creating popular interest in public instruction in Massachusetts; that work Dr. Sears carried forward with great energy, and in the seven years which he devoted

to it secured to the State a very complete system of public schools. For this service he was specially fitted by the intimate acquaintance he had acquired while in Germany with the Prussian system of public instruction. In 1853, on the resignation of Dr. Francis Wayland as president of Brown University, Dr. Sears was chosen to succeed him. This office he held with distinguished ability for twelve years. During his presidency, which covered the troublous period of our civil war, some marked improvements in the finances and appliances of the college, as well as changes in the courses of study, took place. Dr. Wayland had introduced in 1850 the "new system," as it was called, which opened a much wider range of studies in science, and specially in applied science, than had before been offered, and which, withal, introduced the new degree of Bachelor of Philosophy, and made the degrees of A. B. and A. M. obtainable in a shorter time than had previously been possible. This system was gradually modified until 1862, when with the exception of a three years' course for the degree of Bachelor of Philosophy, the old curriculum of four years, with a few electives, as a condition for receiving the degree of A. B., was restored. The first centennial of the University occurring in 1865, the occasion was celebrated with a discourse by Dr. Sears on the history of the University and the work it had accomplished.

When in March, 1867, the trustees to whom Mr. George Peabody had committed the care of the great fund given by him for the education of the children of the Southern and Southwestern States which had suffered from our civil war were about to organize a plan for the distribution of the income of this fund, the Hon. Robert C. Winthrop, with whom rested the chief responsibility of devising a plan, chanced to meet Dr. Sears in Boston, and asked him to favor the committee with his views of what their best plan would be. He complied with this request, furnishing the written statement of a plan which made so favorable an impression on the minds of the trustees that they adopted it, and immediately and unanimously elected him as the general agent by whom the plan should be carried into execution. To accept this agency he resigned the presidency of Brown University and entered on its duties in the fall of 1867. And of all the positions which he occupied that of general agent of the Peabody Educational Fund was the one for which nature, training, experience and tastes seem to have preëminently fitted him. He held it longer than any other, and had life and health been spared would have continued to hold it. He died at Saratoga Springs, July 6, 1880. His decease was deeply deplored by the trustees of the fund, and called forth a warm eulogium from the Hon. Robert C. Winthrop on his character and services. His success in the discharge of the difficult duties of the agency had been complete. Entering on those duties at a time when the Southern mind was naturally very sensitive towards everything and every person coming from the North, he yet won for himself and his work the confidence and support of all kinds of people.

Dr. Sears received the honorary degrees of Doctor of Divinity from Harvard College in 1841; and of Doctor of Laws from Yale College in 1862. In addition to many contributions to Quarterlies, published addresses and educational reports, he was also author (with Edwards and Felton) of *Classical Studies* (1843); *The Ciceroian*, which set forth the Prussian method of teaching Latin (1844); *The Life of Martin Luther* (1850). He also edited Nöthen's German Grammar, with additions (1842); *Select Treatises of Luther*, in German with notes (1846), and Roget's *Thesaurus of English Words and Phrases* (1864).
(E. G. R.)

SEATON, WILLIAM WINSTON (1785-1866), journalist, was born in King William co., Va., Jan. 11, 1785. He was of Scotch descent, and his mother was a cousin of Patrick Henry. He was educated at Richmond, where he became a printer and at an early age engaged in political journalism. He was connected with a newspaper at Petersburg, and owned one at Halifax, N. C. Joseph Gales edited the *Register* at Raleigh, and Seaton joined him in the work, and afterwards married his daughter. In 1812 in company with his brother-in-law he moved to Washington, where they founded the *National Intelligencer*, a journal long conspicuous for its ability, fairness and courtesy. The publishers also compiled a *Register of Debates* extending from 1824, to 1837, and *Annals of Congress* from March 3, 1798 to May 27, 1824. These valuable works are of the highest authority in American history. Gales died in 1860 and Seaton survived him until June 16, 1866. He was honorably connected with the growth of the city of Washington, and was its mayor for twelve years, 1840-51.

SECESSION. The effort of several of the slaveholding States of the Union to separate themselves from those that adhered to the Constitution of the United States is the event to which the term secession has been applied. In 1860 South Carolina assumed to dissolve her connection with the United States and was followed by several of the slaveholding States who together formed a government styled the Confederate States of America. This movement was the natural outcome of the acceptance of the doctrine of States' Rights, that had grown up subsequently to the adoption of the Constitution of the United States, under the influence of local causes peculiar to the condition of the Southern States of the Union. The nature and development of this school of opinion are given under STATES' RIGHTS.

In South Carolina this doctrine had received an interpretation that assumed for it a philosophical basis, that had been supplied by the abstract studies of her great thinker, John C. Calhoun. Conscious that the massing of political powers rendered possible great abuses of such power, detrimental to individual liberty, and fearing the consequences of such abuses, Calhoun overlooked the law of social growth that demanded the existence of highly integrated powers, even though such condition led in the possibility of many evils, and claimed to have found the line of safety in reducing the strength of federated governments to a point that would disable them from committing great wrongs, although the process was one that equally deprived them of the capacity of accomplishing any thing notably good. His idea was that the States of this Union should be united in a way that would make their combined action depend upon diplomatic intercourse between them. Deprived of the power of acting independently of the consent of all the States, hasty and oppressive action would be avoided. In a community of States thus loosely united every step in public affairs would be the product of a compromise painfully worked out of discordant elements. The aspect presented by the States of such a Union would be that of a chain-gang, hobbled and crippled, incapable of intelligent action, and needing a task-master to direct its steps.

While South Carolina was the nidus of disunion she did not assume the leadership of the movement depending on that principle until her institutions and interests were touched by conflicting national interests. The first occasion that brought into activity the consequences of the theory of States Rights was furnished through sympathy with political aspirations deriving their inspiration from the principle of the equality of man in civil society. The French Revolution found a response in Ken-

tucky and Virginia that produced the celebrated Resolutions of 1798, but awakened no heroic sentiment in South Carolina. The reason of this is obvious. The government of South Carolina permitted the least degree of popular intervention in public affairs that was reconcilable with the existence there of popular government. Until the close of the rebellion the only officers in the State chosen at popular elections were the members of the Legislature and of Congress, the sheriffs, and delegates to conventions. The majority of the people of that State were a caste, admitted to no political privileges and under a civil regime that separated them as to their rights and obligations from the residue of her people. Under such circumstances active sympathy with advanced political ideas was not to be expected. The phase of States' Rights agitation induced by opposition to the Alien and Sedition laws was characterized by the presence of a democratic tendency hostile to caste and political monopoly.

The second great upheaval from that same source was in the interest of industries intimately interwoven with slavery. This was the occasion of the attempted nullification by South Carolina of the tariff laws of the United States, and is treated under NULLIFICATION (*q. v.*).

The third and final effort commenced under the leadership of South Carolina, and distinctly propounded the perpetuation of slavery as its object. Thus from fellowship with the most advanced conception of the equal rights of mankind under government, the States' Rights dogma passed into sympathy with, and support of the aristocratic regime of caste, the institutional denial of all that is implied by the term democracy, and the source of oligarchic tendencies. Both nullification and secession united in the support and perpetuation of slavery, the former dealing with slavery through industries of which slavery was regarded as a necessity, and the latter propounding distinctly the perpetuation of that institution as its end. For the steps that were taken by the seceding States in attempting disunion and establishing a confederate government, see CONFEDERATE STATES AND RECONSTRUCTION. (A. J. W.)

SEDALIA, a city of Missouri, county-seat of Pettis co., is at the intersection of the Missouri Pacific and the Missouri, Kansas and Texas Railroad, 189 miles W. of St. Louis. It contains a court-house, 2 opera-houses, 2 national banks, a savings bank, 10 churches, a high school with fine building, a public library, 3 daily and 4 weekly newspapers. Its industrial works comprise car-works, machine-shops, woolen mills, manufactories of agricultural implements, wagons, machinery, soap and furniture. It was founded in 1860, and in 1880 had a population of 9561.

SEDGWICK, CATHARINE MARIA (1789-1867), novelist, was the daughter of Judge Theodore Sedgwick, and was born at Stockbridge, Mass., Dec. 28, 1789. After her father's death, in 1813, she took the management of a school for young ladies, which she conducted for fifty years. In 1822 she published *A New England Tale*, which had grown under her hand while she was preparing a religious tract. Its success led to a second venture, *Redwood* (1824), which attained even greater popularity. Then followed a long series of tales, letters, historical sketches, and a biography of Lucretia M. Davidson (1841). *Hope Leslie* (1827), *Clarence* (1830), and the *Lincolns* (1835), take rank as her best. Her last book was *Letters to My Pupils* (1862). She died at Roxbury, Mass., July 31, 1867. The *Memoir* was published by M. E. Dewey (1871).

SEDGWICK, JOHN (1813-1864), general, was born in Cornwall, Conn., Sept. 13, 1813, and

graduated at West Point in 1837, in a class comprising Gens. Hooker, Bragg and Early. He was appointed 2d lieutenant of artillery, and served against the Seminoles in Florida and subsequently on the frontier during the Canada border troubles. Having been made 1st lieutenant in 1839, he took part in the Mexican war, at the siege of Vera Cruz, the battles of Cerro Gordo, Churubusco, Molino del Rey, and Chapultepec, and in the assault on and capture of the City of Mexico. He was brevetted successively captain and major for gallantry and meritorious conduct. In 1849 he was promoted to captain, and, in 1855, to major of the 1st cavalry, with which he served in Kansas, being subsequently transferred to the 2d cavalry, of which he was lieutenant-colonel at the outbreak of the civil war. In April, 1861, he was appointed colonel of the 4th cavalry, and in August was commissioned a brigadier-general of volunteers and assigned for service in the army of the Potomac. In McClellan's Peninsular campaign of 1862, he commanded a division of Sumner's corps, and took part in the siege of Yorktown and in the pursuit of Johnston. He especially distinguished himself at the battle of Fair Oaks, arriving, after a toilsome march, just in time to decide the day. He took part in all the engagements of the Seven Days' fight, and again won honor at Savage's Station and Glendale. At Antietam he bore a conspicuous part, leading a division and exposing himself fearlessly. Though severely wounded, for two hours he would not allow himself to be taken from the field. Returning to duty in December he was promoted major-general of volunteers, and, in Feb. 1863, put in command of the Sixth corps. At the head of this corps, on May 3, he stormed the heights of Frederick-burg, but with the heavy loss of 5000 men. Continuing his march to effect a junction with the main army, under Hooker, at Chancellorsville, he was checked in the afternoon at Salem Heights by the troops that Lee was able to detach after repulsing Hooker, and on the next morning when Lee further reinforced these it was only by determined fighting Sedgwick could hold his ground. When darkness fell he withdrew across the Rappahannock. (See CHANCELLORSVILLE.) In the subsequent return into Maryland Sedgwick commanded the left wing of the Army of the Potomac, as he did at the ensuing battle of Gettysburg, which he reached on the second day of the fighting, after making a forced march of 35 miles in 20 hours—a feat nearly unparalleled. So severe was the struggle that his corps was brought into action without being allowed time to rest. It was engaged, also, in the third day's fight and in the pursuit on July 5. During the passage of the Rapidan, Nov. 7, 1863, he succeeded by adroit movements in capturing an entire Confederate division. This service Gen. Meade acknowledged in a general order. At the battle of Rappahannock Station, Nov. 7, he commanded the Union right wing, and in the Wilderness campaign, held the same position, under Grant, exhibiting conspicuous gallantry in the sanguinary battles of May 5 and 6, 1864. At Spottsylvania Court House (May 9), while placing some pieces in position in the entrenchments, in front of the Court House, he was struck in the head by a bullet fired by a Confederate sharpshooter and instantly killed. His loss caused the most profound grief not only in his own command by which he was especially beloved (and which in respect of discipline and morale he had made one of the most efficient in the field), but throughout the whole army to which his many noble qualities had endeared him. He had been offered the command of the Army of the Potomac just before it was conferred on Gen. Meade, but his modesty led him to decline it. He commanded it, however, more than once temporarily in Gen. Meade's absence. A monument, cast from cannon

captured by the Sixth corps, was erected to his memory at the Military Academy at West Point in 1868. (J. H.)

SEDGWICK, THEODORE (1746-1813), jurist, was descended from Robert Sedgwick, one of the settlers of Charlestown, Mass., in 1635, who afterwards, while engaged in the expedition against Jamaica in 1656, received a commission as major-general from Cromwell. Part of the family had gone to Hartford, Conn., and here Theodore was born in May, 1746. He entered the Yale College, and having been rusticated for some offence did not return. In 1766 he was admitted to the bar and practised at Great Barrington and afterwards at Sheffield, Mass. He was an ardent patriot and served in the expedition to Canada as an aid to Gen. Thomas. He frequently represented Sheffield in the State Legislature, and in 1785 was a delegate to the Continental Congress. His services in suppressing Shay's Rebellion were important. In 1788 the Massachusetts Convention, under his guidance, ratified the Federal Constitution. In the same year he was speaker of the assembly, and was elected a member of the first Congress under the new constitution. Here he was conspicuous as a Federalist and a laborious statesman. In 1796 he was elected to the U. S. Senate, of which he was made president *pro tem.* in the next year. In 1799 he returned to the lower house, where he was chosen speaker. At the close of this term he was made judge of the Supreme Court of Massachusetts, and so continued till his death at Boston, Jan. 24, 1813. Sedgwick rendered excellent service in Congress, but his fame rests upon his work in the interpretation of the State laws in behalf of liberty. In 1780 in a fugitive slave case he obtained from a State Court a decision which practically brought slavery to an end. Afterwards while judge he strengthened the decision by pronouncing that "one man could not have legitimate property in another."

His son, THEODORE SEDGWICK (1781-1839), was born at Sheffield, Mass., Dec. 31, 1781. He graduated at Yale College in 1798, and having studied law with his father, was admitted to the bar in 1801. He practised at Albany, N. Y., for many years and in 1822 removed to his father's estate at Stockbridge, Mass. He was elected to the Massachusetts legislature and earnestly advocated the construction of a railroad from Boston to Albany. He was a Democrat in politics, opposed to slavery, and an advocate of free trade. Soon after completing a political speech he died of apoplexy at Pittsfield, Nov. 7, 1839. His published works were *Hints to my Countrymen* (1826), and *Public and Private Economy* (3 vols., 1836-39). The later volumes contain his observations on the continent of Europe in 1836. His wife, Susan Ridley Sedgwick, was a daughter of Gov. William Livingston of New Jersey, and wrote many works of fiction for the young.

Their son, THEODORE SEDGWICK (1811-1859), was born at Albany, Jan. 27, 1811. He graduated at Columbia College in 1829, and was admitted to the bar in 1833. He then became an attaché of the U. S. Legation at Paris. Returning in 1835 he practised law in New York city, was president of the Crystal Palace Association in 1852, and in 1858 was U. S. district attorney. He died at Stockbridge, Mass., Dec. 8, 1859. He published a *Memoir of Gov. William Livingston* (1833); a *Treatise on the Measure of Damages* (1847), and many legal, literary and political addresses.

SEDITION. The distinctive recognition of the principle that the people of the community have a right to mould its government to their interests and desires, which existing as a political tendency in the early colonial institutions of this country, came to a distinct expression at the Revolution,

See Vol. XXI, p. 619 (p. 650 Am. Rep.).

had a necessary tendency to displace the ideas of the duty of popular submission to authority that were derived from monarchical institutions. The enunciation of a measure of popular right in excess of what had been regarded as compatible with governmental stability, and which had never been reduced to an exact statement by actual political experience left an important political problem for experimental solution.

This principle, affirming the popular origin of political authority, was the reason of the Declaration of Independence and the sanction of the armed struggle that established its affirmations. In America the ultimate consequences of the tendencies inherent in this new and bold doctrine were counteracted by inherited English tendencies that estimated political institutions according to historic rather than philosophical interpretations. In France a prepared intellectuality that had appealed from history to reason, and popular aspirations intensified under the pressure of dynastic interests had assured the acceptance of the advanced conception of popular right. The displacement of the historic government of that country opened its institutions to the chances of a conflict between reason, rapacity and revenge that soon demonstrated the instability of government not properly related to antecedent experience.

Profound apprehensions were felt by the conservative portion of the American people for the safety of our own government which was thought to be exposed to the influences that were producing the instability of French institutions to a condition that threatened constitutional order in government. It was apprehended that emissaries of ultra-revolutionary ideas would foment among our people dissatisfaction with their government and with established social order and would embarrass if not overthrow the government. The Federal party then in power sought to relate the institutions of the country to past governmental experiences, while a growing sentiment demanded an unshackled advance to certain ideal conditions that attracted the popular enthusiasms.

The apprehensions excited by the condition of politics in France, induced the enactment by Congress in 1798 of the Alien and Sedition laws. The latter prescribed punishment for seditious libels against the government and its officers and for seditious conspiracies, but the law was a temporary expedient expiring by its limitation in 1801. While this law cannot be regarded as an attempt to establish in this country the common law doctrines in regard to sedition it certainly was a reactionary step that failed through its want of adjustment to the principles of government. As regarded the penalties attached to seditious conspiracy the law is not open to the same criticism, but as an attempt to stifle criticism upon the conduct of the government, it certainly misconceived the tendencies that gave direction to thought and action in America.

The policy of the Federal party in this respect had its roots in distrust of popular institutions that did not contain a reserve of governmental authority that in the end could set a limit to popular tendencies. The theory of popular sovereignty was not freed from the influence of the long prevalent notions of personal sovereignty, and it seemed to many gifted minds that the mechanism of government with its inherent conservative tendencies might still supply a check to popular tendencies. If the idea of popular liberty was not clear at that day the instinct associated with that idea was fixed and potent and was the cause of the overthrow of the policy of repressing popular agitation.

In our colonial life we imported the common law of England that thus became the point of departure for whatever might be the distinctive product

of our peculiar conditions and tendencies. The law of England regarded the raising of commotion and disturbance in the State for the purpose of changing the government or its measures as a revolt against legitimate authority and clothed such conduct with the qualities of a public wrong under the name of "sedition." It is more accurate to say that sedition was a parent stock from which a variety of crimes branched out than to say that it was in itself a distinctive crime. While as affecting the life or security of the person of the sovereign, seditious conduct on the part of a single individual might be of consequence, it was only when numbers united for seditious purposes that the stability and authority of the government could be regarded as in jeopardy, and hence the development of the consequences of sedition dealt mainly with the conduct of associated persons. Viewed on this side sedition implied the assembling together of persons from the motive of hostility to the government or its measures and the conduct attending and resulting from such assembling. An unlawful assembly as punished by the law of England was measured by a very vague standard that in its application left much to the state of the times and to the temper of those administering it. A definition of an unlawful assembly as "any meeting whatever of great numbers of people with such circumstances of terror as cannot but endanger the public peace and raise fear and jealousies among the King's subjects," is a net that can be made to catch great or little fish as circumstances might require. If the object of such an assembly was to enforce some personal right or to redress some personal wrong, without any direct bearing upon the government, the most that would result from an attempt to execute its purposes by force, would be to involve the actors in the consequences of the crime of riot. But, if the object was the redress of public grievances, and force was employed, the responsibility was for the consequences of treason.

As the discussion of radical changes in the structure and policy of government must produce those consequences above described as indicating an unlawful assembly it is evident that the system that gave rise to such definitions of the limitations of popular action was essentially based upon the idea that such changes could not properly originate with the mass of the people. Such a system could have no place in the doctrines of America, and the attempt to graft it upon our institutions was a serious error that had a large share in revolutionizing the state of parties and opinions in the United States. At the present day the term "sedition" hardly has a place in the law language of this country. Its only use in the statutes of the United States is in connection with the regulations for the government of the army and the navy, where sedition is named as a military offence.

The attempt to change the structure or to control or resist the operations of the government by force has not lost the character derived from the institutions of England, for the principles of popular government while giving the utmost liberty to rational methods find no place for brute force. It is true that we have limited the scope of the crime of treason to the case of armed hostility to the government, but in various forms penal consequences have been attached to applications of force to antagonize the operations of the government.

The right of the people to assemble and deliberate upon public grievances is fixed in the constitution of the United States and those of the States, so that the popular assembly, whether deliberating upon changes in the structure or operations of the government or on the conduct of those administering it, is placed upon highest ground of privilege beyond the control of the law-making authority so

long as its deliberations are confined to rational methods to the exclusion of turbulence and violence.

What has been done by constitutional authority to conserve the formation and expression of collective opinion as affecting the government has also been done for the protection of individual opinion. The liberty of speech and of the press secured by all of our Constitutions assures to the individual immunity in the free expression of his opinions, though involving in condemnation the conduct of the government or of its officers, placing such expressions upon the ground of privilege and freeing him from responsibility except for the truth of statements prejudicial to personal character.

These constitutional rights preclude the application of the principles upon which the doctrine of sedition rests to the relations between the citizen and his government so long as force is absent. As the doctrine of bygone times sought to shield the government from popular criticism the modern constitutional liberty distinctly invites that criticism and bestows upon it the highest immunity. (See STATES' RIGHTS.) (A. J. W.)

SEELEY, JOHN ROBERT, English author, was born in London in 1834. He graduated at Christ's College, Cambridge, in 1857, and became fellow in 1858. He was made professor of Latin in University College, London, in 1863, and professor of modern history at Cambridge in 1869. To him is attributed *Exe Homo* (1865), a work which produced a profound sensation throughout the English-speaking world. It professed to be a survey of the life and work of Jesus Christ. Discarding all theological systems, the author took the narrative of the Gospels, and endeavored to prove the influence of Jesus to be due to an "enthusiasm of humanity," of which he was the exemplar and advocate. So great was the effect of the book that the author seems to have recoiled from pursuing the plan announced in his preface. Instead of issuing a work on the religious system of the Gospels, he waited till 1882 before publishing *Natural Religion*, a work which has attracted much less attention than his former. In the field of modern history Prof. Seeley has treated with marked ability the themes he has handled. His *Life and Times of Stein* (3 vols., 1879) has made known in English the true source of the recent greatness of the German empire, while the *Expansion of England* (1883) is a graphic presentation of the growth of the British empire. His *Short History of Napoleon I.* (1886) is a severe indictment of the French emperor as a selfish charlatan.

SEELYE, JULIUS HAWLEY, educator, was born at Bethel, Conn., Sept. 14, 1824. He graduated at Amherst College in 1849, studied theology at Andover, and went to Germany for further study. In 1853 he was ordained pastor of the first Reformed Church at Schenectady, N. Y. In 1858 he was recalled to Amherst College as professor of moral and mental philosophy. In 1872 he visited India and delivered lectures to educated English-speaking Hindoos on the truths of Christianity. These were afterwards published at Bombay and Boston under the title *The Way, the Truth, and the Life* (1874). In 1874 the people of his Congressional district, discontented with previous political management, nominated and elected him to Congress. He served but one term, and was chosen president of Amherst College in 1876, while still retaining his professorship. His earnest Christian character has served to raise the standard of education, of public opinion and political action. Besides contributions to reviews and many sermons and addresses, he has published *Christian Missions* (1875).

His brother, LAWRENCE CLARK SEELYE, born at Bethel, Conn., Sept. 20, 1837, graduated at Union

College in 1857, studied theology at Andover, and afterwards at Berlin and Heidelberg. Returning after a tour extended to Palestine, he was ordained pastor of a Congregational Church at Springfield, Mass., in 1863. He was made professor of English literature and oratory in Amherst College in 1865, and in 1874 was called to be president of the newly founded Smith College for Women, at Northampton, Mass. He has contributed to periodical literature on educational topics and has prepared some articles for this work.

SEGULN, ÉDOUARD (1812-1880), physician, noted for his success in training idiots, was born at Clamecy, France, Jan. 20, 1812. He was educated at colleges of Auxerre and of St. Louis, Paris. While studying medicine with Itard, who had given some attention to the treatment of idiots, Seguin was induced to pursue the subject more thoroughly. In his first experiments he was associated with E. D. Esquirol, and in 1838 he opened a school for this class of patients in the Faubourg St. Martin, Paris. His system received the approval of the French Academy of Sciences in 1845, and he then published *Traitement morale, Hygiène et Éducation des Idiots* (1846). The revolution of 1848 having interrupted his work at Paris, he visited the United States, where some institutions had already been founded to carry out his ideas. He assisted Dr. H. B. Wilbur in starting the school which grew into the New York State Asylum at Syracuse. In 1851 he settled in Ohio, but he afterwards taught at Syracuse, and then practised as a physician at Mt. Vernon, N. Y. At intervals he was engaged in founding asylums for idiots in other States. In 1863 he settled in New York city, and there enjoyed high repute as a specialist in nervous diseases. In 1873 he was U. S. Commissioner of Education at the Vienna Exposition, 1873, and he prepared the official report on that department. He died at New York, Oct. 28, 1880. To him the medical profession owes the physiological thermometer. Among his publications in English were *Idiocy and its Treatment by the Physiological Method* (1866); *Medical Thermometry* (1871), and several other treatises on these subjects.

SEISS, JOSEPH AUGUSTUS, Lutheran minister, was born near Graceland, Md., March 18, 1823. He was educated at Pennsylvania College, but did not graduate, though he afterwards received the degree of D. D. from this institution. Having studied theology privately, he became pastor at Martinsburg, Va., in 1843. He afterwards had charge of churches at Cumberland, Md. (1847), Baltimore (1852), and in Philadelphia first of St. John's (1858), and later of the Church of the Holy Communion (1874). In 1858 he took part in forming the General Council of the Lutheran Church. He edited the *Prophetic Times*, a monthly, 1863-75, and the *Lutheran* 1873-79, having previously been associate editor for some years. He has published lectures on the Epistle to the Hebrews (1846), on Leviticus (1860), on the Apocalypse (3 vols., 1870-84), on the Gospels (2 vols., 1876), on Daniel (1879), and many other sermons. His millenarian views of prophecy are set forth in these and in *Last Times* (1856). His *Miracle in Stone* (1877) adopts the views of Prof. C. Piazzi Smyth in regard to the great pyramid of Egypt and pronounces it to be a record and attestation of divine revelation. In *The Gospel in the Stars* (1882), he considers the constellations to be a typical display of Christian truth. His *Ecclesia Lutherana* (1867), *Luther and the Reformation* (1883), and various manuals relate chiefly to his own denomination.

SELBORNE, ROUNDELL PALMER, EARL OF, was born at Mixburg, England, Nov. 27, 1812, his father being rector of that parish. He was educated at Rugby and Winchester schools, and at Trinity

College, Oxford, where he graduated in 1834. He had won prizes for Latin and English verse. He became fellow of Magdalen College, and in 1837 was called to the bar at Lincoln's Inn. He was made Queen's Counsel in 1849, having been already elected to Parliament from Plymouth. In 1852 he was defeated, but in the next year he regained his seat, which he held till 1857. He was then classed as a Liberal Conservative, but afterwards became distinctly liberal. In 1861 he was appointed solicitor-general in Lord Palmerston's administration and was knighted. He became a member for Richmond and represented this borough until he was elevated to the peerage in 1872. He was made attorney-general in Oct., 1863, under Lord John Russell, and retired with him in June, 1866. When Mr. Gladstone came into power in Dec., 1868, he offered to make Sir Roundell Palmer chancellor, but the latter being unable to approve fully the course proposed in regard to the disestablishment and disendowment of the Irish Church, then declined the office, though he continued to support the Government policy on most public questions. He was counsel for Great Britain before the Geneva tribunal of arbitration in 1871. In October, 1872, he was appointed Lord Chancellor of England, and was raised to the peerage by the title Baron Selborne of Selborne. He retired with Gladstone in February, 1874, and returned to his former office when the liberals were victorious in 1880. In December, 1882, he was created Viscount Wolmer, of Blackmoor, and Earl of Selborne. He retired again with Mr. Gladstone in 1885. Sir Roundell Palmer was noted not only for his legal labors, but also for his literary attainments. His *Book of Praise* (1862) is an admirable selection from the best English hymn writers. In 1863 he received the degree of D.C.L. from the University of Oxford, and in 1877 he was elected Lord Rector of the University of St. Andrews.

SELMA, a city of Alabama, county seat of Dallas co., is on a bluff on the right bank of the Alabama river, 160 miles N. of Mobile. It is at the intersection of several railroads leading to Mobile, New Orleans, Memphis, and Atlanta. It has a courthouse, a national bank, savings bank, 2 academies, 20 churches, and 1 daily and 2 weekly newspapers. The industrial works comprise iron works, cotton factories, planing mills, car shops, and other manufactories. A large trade in cotton is carried on. The town is lighted with gas. In 1880 it had a population of 7529.

SELWYN, GEORGE AUGUSTUS (1809-1878), an English missionary bishop, was born at Richmond in Surrey, being son of William Selwyn, Q. C., of some repute as the author of a work on *The Law of Nisi Prius* (1806-8). George was educated at Eton and at St. John's College, Cambridge. After being for a time tutor at Eton and curate at Windsor, he was consecrated first bishop of New Zealand in 1841, and in this post, which he filled for 26 years, won great reputation for apostolic zeal and efficiency. In his own small vessel, *The Southern Cross*, and often at great personal risk, he visited the South Sea Islands, and thence brought to New Zealand native youths whom he instructed and sent back as missionaries. J. C. Patteson, afterwards bishop and martyr (for whom see ENCYCLOPEDIA BRITANNICA), became his assistant in this part of the work in 1855. His jurisdiction was divided in 1857. He was recalled to England in 1867, having been appointed Bishop of Lichfield and administered his diocese with great energy and success. On a visit to the United States in 1874 he was received with much attention, as one of the most eminent and beloved British prelates. His publications include *Are Cathedral Institutions Useless?* (1838), *Remarks on Cathedral Reform* (1839), *Sermons* (1842), a *Charge to his clergy* (1849), *The Work of Christ in the*

World (1855), and a *Verbal Analysis of the Bible* (1855). He died at Lichfield April 11, 1878; his *Memoir* was written by H. W. Tucker (2 vols. 1879). His son succeeded Patteson as Bishop of Melanesia, and his brother, WILLIAM SELWYN (1806-1873), was divinity professor at Cambridge from 1855, author of several books, and a reviser of the translation of the Old Testament.

SEMINOLES, a tribe of Indians, whose name is associated with the history of Florida, now reside chiefly in Indian Territory. They belong to the Creek or Muscogee family, and having separated from the main body in 1750, were called Seminoles or "wanderers." Parts of other tribes joined with them, and during the American Revolution they gave much trouble to the people of Georgia. In 1784 the Spaniards, having recovered Florida, made a treaty with the Tallapoosas and Seminoles. The latter claiming to be a distinct tribe, repudiated the treaty made in their behalf with the United States by the Creeks in 1790. They soon began to make raids into Georgia and afforded refuge to fugitive slaves. The Creek war of Northern Georgia extended to them, and one of their forts being destroyed they took revenge by the massacre of Lieut. Scott and others. Gen. Gaines drove them from Georgia, and Gen. Jackson pursued them into Florida and destroyed their towns. In 1819, when Florida was purchased by the United States, they were found to number less than 4000 Indians with about 800 negroes. As they roamed over the whole country efforts were made to dispossess them. By the treaty of Fort Moultrie, Sept. 18, 1823, but somewhat modified in the following January, they gave up most of their lands for annuities which would amount to \$100,000, agreed to deliver up fugitive slaves, and accepted small reserves of land. But the white settlers pressed for their complete removal, and in 1832 Seminole chiefs were deluded into making a treaty for this purpose at Payne's Landing. Although this treaty was rejected by nearly all the tribe President Jackson and the U. S. Senate determined to enforce it. When the chiefs opposed the attempt, Gen. Thompson, the U. S. agent, undertook to depose them, and arresting Osceola, put him in irons. On Dec. 28, 1835, Osceola killed Thompson, and inaugurated a bloody war which cost the United States over \$10,000,000 and 1500 lives. Though the Seminoles struggled bravely, most of them early in 1837 agreed to emigrate. Osceola, however, still fought until he was treacherously seized in October. In 1839 there had been 1900 Seminoles removed to the Indian Territory, where they were handed over to the Creeks. Many of them dissatisfied with their treatment went on to the Rio Grande, and their descendants are still to be found in Mexico. In 1845 and 1856 better treaties were made with those in Indian Territory, giving them a separate reservation. Those who still stayed in Florida had sought refuge in the Everglades, under their chief Billy Bowlegs, but finally most of these also emigrated in 1858. All told, 2254 Seminoles were then found in Indian Territory. The tribe divided on the outbreak of the civil war, and the Confederate government made a treaty with the larger portion, assuming all the obligations of the United States towards them. The loyal Seminoles were defeated in a severe fight on Dec. 25, 1861, and retreated into Kansas. In 1865 they rejoined the main tribe, and their old reservation being purchased by the U. S. government, they obtained a new one from the Creeks. A census showed their number 2959, including some negroes. There were others in Florida and Texas. Those in Indian Territory have made considerable improvement under the training of Presbyterian missionaries. Under the treaty of 1866 they receive an annuity of \$25,000, besides \$2500 for schools and \$1000 for

government expenses. In 1887 they were reported as numbering 3000, who all wear citizens' dress; 1200 use English sufficiently for ordinary conversation and 800 can read. There are 8 churches with 500 church members. They have about 6000 acres under fence and cultivated. Efforts have been made in recent years to set apart homesteads in Florida for those still remaining there, but no land has been found unlocated which the Indians are willing to accept. These are said to number 892.

(J. P. L.)

SEMMES, RAPHAEL (1809-1877), Confederate naval officer, was born in Charles county, Md., Sept. 27, 1809. He entered the U. S. navy in 1826, but afterwards resigned and engaged in the practice of law in his native State. In the Mexican war he again entered the service, and when his vessel was lost during the siege of Vera Cruz, he joined Gen. Scott's army as a volunteer. His experience then furnished material for his *Service Afloat and Ashore* (1831), and *Campaign of General Scott* (1832). In 1855 he attained the rank of commander, and he was made secretary of the Lighthouse Board. When the Southern Confederacy was organized he resigned and went to New Orleans. Taking command of the sidewheel steamer *Sumter*, he dashed through the blockading squadron at the mouth of the Mississippi. His career of destruction has been narrated under **ALABAMA CLAIMS** (*q. v.*). Before the war closed he had returned to Mobile, and on its capture he was imprisoned for some months, but was released without trial. He was afterwards an editor at Memphis, then a professor in New Orleans, and a lawyer in Mobile. He published *Cruise of the Alabama* (1864), and *Memoir of Service Afloat during the War between the States* (1869). He died near Mobile, Aug. 30, 1877.

SENECA FALLS, an incorporated village of Seneca co., N. Y., is on the Seneca River, 10 miles from Seneca Lake, and 2 miles W. of Cayuga Lake. It is 16 miles from Auburn and 62 miles from Rochester, on the Auburn Branch of the New York Central Railroad. It has short railroads to Waterloo and to Cayuga Lake. It contains an opera-house, a national bank and 2 other banks, 4 hotels, 7 churches, 5 schools and has 2 weekly newspapers. The river here falls 50 feet and furnishes motive power for 4 flouring mills, 1 woolen mill, 1 knitting mill, 5 foundries, and manufactories of steam fire engines, pumps and agricultural implements. The village is lighted with gas and has waterworks and a park. Its property was valued at \$30,000,000; the public debt is \$30,000 and the yearly expenses \$25,000. It was settled in 1787 by Job Smith, and was incorporated in 1831. The population in 1880 was 5880.

SENECAS. See **IROQUOIS**.

SEPTUAGINT. A few years ago, it was customary among scholars utterly to discredit the traditional accounts of the origin of the Septuagint, and to assign very late dates to the making of the successive parts of this translation. Of late years,

See Vol. XXI. p. 668 (p. 699 Am. Rep.).

there has been a decided and healthy reaction against this extreme opinion. A majority of living scholars, probably, would agree with Prof. J. Wellhausen, in his statement in the **ENCYCLOPÆDIA BRITANNICA**, that the letter of Aristæus, the principal source of information concerning the origin of the Septuagint, was written as early as the earlier half of the second century B. C., and that the translation itself may probably have been begun in the times of Ptolemy Philadelphus, and was certainly finished, so far as the canonical books are concerned, some time before 130 B. C. When, however, he says that the Septuagint "was in great part composed before the close of the canon—nay, before some of the Hagiographa were written," his impli-

cation as to the lateness of the date of some of the Hagiographa, and of the closing of the canon would not be so widely accepted.

Beyond certain general facts, no statements now made concerning the Septuagint can be regarded as final. Good preliminary work is now being done on it in the way of textual criticism, but ripe results in regard to the text are still an affair of the future. And any one who has read the statements currently made as to the external testimony to the Septuagint, and has dipped somewhat into the original sources of this testimony, knows that a wider and better induction of facts is as much needed in this field as in that of Septuagint textual criticism.

The article in the **ENCYCLOPÆDIA BRITANNICA** avoids the very common mistake of attributing to Aristæus or Josephus the statement that the Septuagint had miraculous sanctions. An account of these alleged miracles is given by Philo, and a different account by Epiphanius, and the miracles are alluded to by other Christian writers, but there is nothing of the kind in Aristæus. Our author further mentions certain guarantees of its own antiquity and of trustworthiness in at least some points, found in the letter of Aristæus itself—the ante-Seleucid character of what it says about the Jews, for example, and its peculiar correctness in details, as confirmed by papyri and inscriptions of the times of Ptolemy Philadelphus. He regards it as not intrinsically improbable "that the scholarly taste of the Alexandrians, personified in Demetrius Phalereus as the presiding genius of the Alexandrian library, could have furnished the stimulus to reduce the translation to writing." That this was actually the case, however, he seems to deny, holding that Demetrius died so early in the reign of Philadelphus that he cannot possibly have done this work. But the epistle of Aristæus does not so much as mention that the king of whom it speaks is Philadelphus, though the reader may gather this fact by inference. In some of the other traditions, the name of Ptolemy Lagus is connected with the Septuagint. Remembering this, and remembering that Ptolemy Lagus lived perhaps two years after he placed Philadelphus on the throne, 285 B. C., we see that it is not improbable that Demetrius may have had something very important to do with the actual placing of the Judean sacred books in the Alexandrian library. So far as appears from all known sources of evidence, he may have remained in Alexandria, and may have been employed in literary work there, till after the death of Lagus; and this fact must be allowed to limit the statement that he "fell out of favor at the very beginning of the reign of Philadelphus." The statement of Aristæus that when the interpreters had agreed upon a section, Demetrius wrote it down, may naturally mean, as some of the Christian Fathers seem to have understood it to mean, that he furnished professional writers to do the writing. On the whole, it is hardly fair to the letter of Aristæus to call it a forgery and spurious and accuse its author of mendacity. The letter seems to be a professed fiction based on fact, designed largely to place the philosophical questions it discusses in an interesting light. The problem is to distinguish, if possible, the historical basis of fact from the fiction based upon it.

From various Jewish and Christian sources there may be gleaned a few statements of fact in regard to the origin of the Septuagint, that are independent of Aristæus. In the Rabbinical writings may be found the mention of the five scribes who wrote for Ptolemy, and various other allusions to the translation, coupled with a most scrupulous abstinence from directly recognizing it by citing from it. In Philo and in Justin Martyr, Epiphanius, and other Christian Fathers, we have details of circumstances, especially dwelling upon the division of

translators into pairs, and upon the miraculous correspondence of their Greek with the original, or of the changes made by some of the translators with those independently made by others. Not to dwell upon these, two passages out of many may be cited, as containing matters of special interest. The first is the testimony of Aristobulus, as given to Eusebius, *Præp. Evang.* XIII. xi. (See Migne's *Patr. Græc.*, Vol. xxi., col. 1038. Also the *Stromata* of Clement, I. xv., xxii., in Migne, Vol. viii. 781, 889-893):

"It is evident that Plato followed our law, and he was evidently a careful student of everything in it. For there had been translated before Demetrius Phalereus, through others, before the conquest of Alexander and the Persians, the matters pertaining to the going forth of the Hebrews, our fellow citizens, from Egypt, and the manifestation of all that happened to them, and the conquest of the land, and the detailed account of the whole legislation. . . . But the whole translation of all things pertaining to the law was in the time of him called King Philadelphus, thy ancestor, . . . Demetrius Phalereus being active in these matters."

These words are addressed to Ptolemy Philometor, who reigned B. C. 181-146. The other passage is from the *Stromata* of Clement of Alexandria, who lived, say, A. D. 160-215. (Migne, Vol. viii. 894):

"They say the Scriptures, both of the law and the prophetic, to have been interpreted from the dialect of the Hebrews into the Greek tongue in the time of King Ptolemy Lagus, or, as some say, of the one called Philadelphus, Demetrius Phalereus bringing to this the greatest ambition, and providing the things concerning the interpretation."

Probably no one doubts that the conclusions of Clement, though he was a Christian, fairly represent the Alexandrian Hellenistic traditions.

There is no room in this article to exhibit a collection of the numerous items of evidence of which these are specimens, or to discuss their text, or their relative historicity; but attention should be called to certain statements of fact which are greatly neglected, but which are a part of the evidence as it stands. To the extent to which these differ from opinions commonly received, they are here presented rather as questions for inquiry than as final facts.

It is generally agreed, on the basis of the internal character of the Septuagint, and in opposition to most of the external testimony, that the translation is certainly the work of Alexandrian Jews, and not of men whose education was Palestinian. It is further agreed that the translations of the different parts of the canonical books are not all by the same groups of men, or of the same date.

On the strength of the external testimony, uncontradicted by any of the internal marks, or by any of the probabilities of the case, we ought to hold that about 285 B. C., the date at which Ptolemy Philadelphus succeeded Ptolemy Soter, some arrangement was made for putting the Jewish sacred books in the Alexandrian library, and some correspondence was had with the Palestinian Jews for this purpose. Very likely much that is said of the agency of Demetrius in the matter is fabulous; but he seems to have had something to do with it, and that fixes the date, as we have seen, to a time when Lagus was yet living. Perhaps Lagus really had as much to do with it as Philadelphus, though the latter, surviving Lagus and Demetrius, got the credit. Any possible use to which these books were put, in the synagogues or the schools, would of course not interfere with their availability for the library.

In a great variety of ways, both directly and by implication, the testimony affirms that portions of the Jewish sacred books were accessible to Greek-speaking people, in Egypt, before this translation

was made, and that Greek philosophers and literary men actually used them and drew from them as sources. We have found Aristobulus asserting that this was the case even before the conquests of Alexander and the Persians. This statement is very generally regarded as unreasonable; critics on one side ridicule it as discrediting the whole passage, while those on the other side offer explanations of it. But recent explorations confirm the statements of the Hellenists in regard to Greek elements in Egypt as early as the times of Nebuchadnezzar, and show it to be not unlikely that Jeremiah and his fellow exiles in Egypt may there have come into contact with Greeks. But laying all this aside, there is every probability that for a generation or more before the accession of Philadelphus, the Greek-speaking Samaritans and Jews in Alexandria, with Greeks who were interested in foreign literatures, had made some progress in turning the Scriptures into both oral and written Greek.

Among the neglected points in the testimony is the statement, often repeated, that Ptolemy had the sacred books transcribed, as well as translated. Demetrius said to the king: "It has been told me that there are laws (*νόμους*) of the Jews worthy of being transcribed and placed in the library." In reply to the king's question as to what difficulty there was in the way of acquiring them, Demetrius mentioned, among other things, their being written in a peculiar character, like that of the Syrians, though not the same with it, *Aristæus* in Hody, page ii. Later, Demetrius says: "For the laws (*νομοθεσίας*), which we wish not only to transcribe but to interpret, concern all the Jews," page iii., and *Jos. Ant.* XII. ii., 2. And so the account proceeds throughout *Aristæus* and *Josephus*. Epiphanius says substantially the same thing, and Lightfoot has shown (in several places, see index of his works) that the Talmudic passages referring to what was done by Ptolemy contemplate a transcription; the more natural understanding. Lightfoot's inference is that the Talmudists recognize no translation, but only a transcription; the more natural understanding of the whole testimony is that there was both a transcription (perhaps a transliteration of the Hebrew in Greek letters) and a translation, and that the traditions have largely confused the two, occasionally asserting of the one something that would be true of the other. In this way, for example, the tradition concerning the participation of the Jerusalem Jews in the affair might be plausibly accounted for. It is certain that they had not much to do with the translation, but their assistance may have been very important in preparing the transcription.

This becomes the more important when we notice that, according to the testimony, the great care taken by Ptolemy was for the purpose of securing a correct text, Hody, page v., *Jos. Ant.* XII. ii., 3, 10 (4, 11), etc. So far as appears, the king might have ordered a copy of the Jewish books for his library from any large vendor of books, but what he wanted was not some copy or other, but a perfectly authenticated copy. There is nothing to contradict the idea that the transcription, supposing it to be true that there was a transcription, may have been such a copy. The idea of taking pains to secure such a copy, even at very great cost, is quite in accord with other things that were done in Alexandria in those days. And if the Jewish scribes of the law were then as painstaking as they were a few centuries later, and had here an opportunity to show their highest skill, it must have seemed to the appreciative courtiers of the king so wonderful as to attract attention; it would be a plausible theory that this fact of the wonderful accuracy of the transcription was the nucleus around which, later, gathered the fables transmitted by Philo and the

Christian Fathers, as to the miraculous accuracy of the translation.

Contrary to the opinion now commonly held, the books which it was proposed to put in the king's library were, if the testimony in the case is to be believed, not the books of the Pentateuch merely, but the books of the Jewish law in the wider sense of the term. In the article in the *ENCYCLOPÆDIA BRITANNICA* it is said that the author of the letter of Aristæus "limits canonicity to the law and knows of no other holy book already translated into Greek." Now it is true that the author of the letter designates the books that were to be translated as the law, but he nowhere gives any hint that he means by the term the five books of Moses as distinguished from other works of prophetic origin. Throughout the Old Testament, the word law is used in a sense wide enough to include all divine requirements made known through the prophets, and therefore, of course, all requirements so made known in writing. In the New Testament, it is frequently used in the same wider meaning. There is no presumption against its having this same wide meaning in the accounts of the origin of the Septuagint, as given by Aristæus and Josephus. We are not now inquiring, let us remember, whether the testimony is to the effect that the plan was actually carried out, so that the other books were translated at the same time with the Pentateuch: nor are we directly inquiring whether the Old Testament canon was then complete in the shape in which it is now accepted. Whatever be the answer to either of these questions, it is evident that the Aristæan account may supposably mean, by the term law, not the Pentateuch by itself, but the whole range of writings that were then regarded as having been divinely given through the prophets, the Pentateuch being of course included.

It is not only true that this may be the meaning, but that this is the most natural meaning. No one disputes that most (not to say all) of the Old Testament books had then been written and were well known; or that they were attributed to prophets, and therefore regarded as of the nature of prophetic *Torah*. The Alexandrian library was an affair of tens of thousands of volumes. The king proposed to gather into it all the literature of the world. It is not natural to hold that he would be content with only a small section of the Judæan sacred literature, unless the evidence distinctly specifies that this was the case; and there is no such specification. On the contrary, the language currently employed both in Aristæus and in Josephus is such as constantly to suggest that the books spoken of are a considerable number of volumes—a more extensive literature, certainly, than the five books of the Pentateuch. Among the expressions employed are: "The books of the law of the Jews, with some few others," "the books of the legislation of the Jews, with others," "many volumes of their usages (*πολλὰ . . . τῶν παρ' αὐτοῦ νομίμων συγγραμμάτων*)," "make a collection of them," "the Jewish books." When the seventy come to the king, they bring, not the one roll of the Pentateuch, but several volumes, made each of skins so closely joined that the king could not find the seams; and when the king had inspected them, they restored the various documents (*τεύχη*) to their proper order. In view of the advice of Demetrius to take measures for obtaining these Judæan writings, it is represented that the king "thought that Demetrius was very zealous to procure for him the multitude of the books." It needs no pressure upon these and similar phrases to make them justify the inference already drawn from them. Indeed, if by the law we understand the Old Testament canon, then the phrase "the books of the law of the Jews, with some few others," is an accurate description of the Septuagint as it has

actually existed since the second century B. C., while it would be difficult to give a precise definition to the phrase, on the supposition that by the law it means the Pentateuch.

But it is sometimes alleged that Josephus has testified to his own opinion of the proper interpretation of this testimony, in the following passage in the Preface to the *Antiquities*, sec. 3, where he says of Ptolemy:

"For he did not succeed in obtaining all the record (*ἀγαράφῃ*), but those who were sent to Alexandria in the matter of the *exegesis* transmitted only what was of the law, while the affairs published through the sacred literature (*ὑραμμάτων*) are myriads."

Many take it for granted that by the law Josephus here means the Pentateuch, and by the records and the sacred literature he means the other Old Testament books. But if this were the case, his position would be too evidently false to be plausible. He says that the one reason for writing his *Antiquities* is that he may place within the reach of the Greeks such of the contents of this "record" and "sacred literature" as had not been rendered accessible by the translation of Ptolemy; but when he pounds this, all the Old Testament and some of the Apocrypha had been thus accessible for two centuries or more, whether Ptolemy made the translation or not. Unless this passage in Josephus is mere nonsense, the other sacred literature which he here proposes to open to the Greeks must be the secondary sacred books which he uses in different parts of his narrative, and the law, whose translation he here ascribes to Ptolemy, is the Old Testament, and not the Pentateuch alone.

The extra-Aristæan testimony to the same effect is explicit and abundant. We have found Aristobulus testifying that the history of the exodus and of the conquest and all the legislation, that is, apparently, the contents of the Pentateuch, had been translated before Ptolemy Philadelphus, and that, in contrast with this, the work of Philadelphus was the whole translation of all things pertaining to the law. Clement held that the works translated under Demetrius were "the Scriptures, both of the law and the prophetic." The whole line of the Christian patristic testimony is to the same effect, with great abundance of details. Philo and the other earlier Jewish witnesses are simply silent; their testimony occurs in passages where only the Pentateuch is under consideration, and nothing at all is either said or implied concerning the other books.

Among the great questions now under discussion by scholars there are two in regard to which the testimony of the Septuagint is of especial importance: the question of the canon of the Old Testament, and the question of its text.

The fact that copies of the Septuagint contain writings not found in the Hebrew is sometimes urged in proof that the Alexandrian canon of the Old Testament differed materially from that accepted in Palestine. That the truth of this view depends partly on the definition given to it, and that it is untrue in any sense that would justify the inference that the canon of the Old Testament was still unsettled among the Jews of the century before Christ and later has been shown in the article on *CANON*, in this work.

Among the groups of scholars who formerly most insisted on the alleged differences between the Alexandrian and the Palestinian canons, there seems to have been some change of opinion during the years since the present edition of the *ENCYCLOPÆDIA BRITANNICA* began to appear. Prof. Wellhausen, in the article on the *SEPTUAGINT*, distinctly says that "in some measure the widening of the Old Testament canon in the Septuagint must be laid to the account of Christians;" and he is speaking

of the canon in Hebrew when he says: "Learned Hellenists were quite well aware of the limits of the canon, and respected them." One cannot logically say this without admitting that the Septuagint, as existing, gives its evidence in favor of the accepted Hebrew canon.

But what does the evidence of the Septuagint amount to in regard to the Old Testament canon of 285 B. C. and earlier?

First, as we have already seen, it is not a witness in favor of the proposition that canonicity was then limited to the Pentateuch. On the contrary, the whole body of the external testimony is to the effect that there was then a clearly recognized body of Jewish sacred law, having its own limits, and much wider than the Pentateuch. There is nothing in the internal phenomena to contradict this. To what extent certain parts of the translation were later than others is a matter yet to be determined; precisely what plans were formed in the times of Philadelphus in regard to the Jewish Scriptures, and how far these plans were carried out, may be matter of doubt; but in this there is nothing to contradict the testimony that attributes to the men of those times the holding of a distinct idea of this body of writings concerning which it was possible for them to form their plans. They knew of a body of Jewish sacred writings described as the law. This law was not the Pentateuch, but a larger body of writings, including the Pentateuch. If our present Old Testament was then in existence as a collection of books, the term law is a natural term for them to apply to it. What they proposed to translate was the law and a few other Jewish books; from about the time when the letter of Aristæus was written, the translated part of the Septuagint has consisted of the Old Testament and a few other books. These facts are of some weight as indicating that our present Old Testament canon was recognized at the beginning of the third century B. C. If they are compared with facts drawn from other sources, they will gain force, instead of weakening.

The remaining question is as to the value of the Septuagint for testing or correcting the Masoretic text of the Old Testament. In reaching conclusions upon this, a few undisputed facts should be kept steadily in mind. From a date earlier than the earliest existing copies of the Septuagint, the Masoretic text has been handed down with a scrupulous care not paralleled in the history of other writings. It is traditionally claimed that this care in transmission goes back to the times when the books were written and collected. There is considerable evidence that might be gathered in support of this claim. Apart from the Septuagint variants, there is no strong proof against it. The variants in the duplicated passages in the Old Testament are not proof of this sort, for they are ordinarily to be regarded as editorial, and not as transcriptional. Prof. Wellhausen in the *ENCYCLOPEDIA BRITANNICA* urges the occasional infelicities of the Hebrew text as proof. With commendable piety, he speaks of "the design of Providence, which has permitted the Old Testament text to reach us in a form that is often so corrupt as to sin against both the laws of logic and of grammar—of rhetorical and poetical form." But really, the instances of a false use of language in the Old Testament are relatively very few; they are not more numerous or more important than are to be expected in such a literature; there is no need of regarding most of them as transcriptional errors, for they are sufficiently accounted for by the state of literary culture existing among their authors. If a collection of writings like these, written by many different men, most of them men whose peculiarities and native vigor have not been polished away by special training, presented no difficulties to one who would parse or translate them, that very circum-

stance would justify a suspicion that some one had corrected the text, and edited out the original peculiarities of it.

If the character of the Masoretic text as a standard text scrupulously transmitted has actually come down to us from the centuries before Christ, then it is of the highest possible order of trustworthiness; and among those who deny it this preëminence, no one would hesitate to say that it is a text of high character, as compared with other texts. When men apply to it such terms as bad and corrupt, they use language relatively; as a text it is not to be classed somewhere from low to medium, nor even from medium to high, but somewhere between high and highest. On the other hand, the different copies of the Septuagint, by universal admission, have rather a low value for trustworthiness. Whether we inquire into the Hebrew scholarship of the translators, or their Greek scholarship, or their probable faithfulness in following whatever text they had, the best that can be said of them is that they did as well as could be expected. Their work is partly translation, partly paraphrase, partly comment, partly abridgment. Doubtless it was originally of this character, and these original variations have been augmented by copyists. The existing copies differ greatly among themselves.

Provided these admitted facts be kept in mind, and allowed their due weight in every process, no one need hesitate to regard the Septuagint as an important aid in the study of Old Testament textual criticism. One need not even hesitate to use the extreme rule laid down by Prof. Wellhausen in the *BRITANNICA*, that in looking up variants for the Masoretic text, "we must not confine ourselves to one recension, but use all recensions that our MSS. offer." But when we come to estimate the value of one of these variants, as compared with the reading of the Hebrew, and ask the question whether we should substitute the variant for the Masoretic reading, we have no right to forget the immense difference in trustworthiness between the two witnesses; and if we remember this, the cases will be very few indeed in which any Septuagint variant is preferred to the Masoretic reading.

The fact that a Greek phrase in the Septuagint can be translated into a Hebrew phrase by no means proves that the Greek translator found that particular Hebrew phrase in his copy. The rule that "the proof that a reading is good is simply that it necessarily carries us back to the Hebrew variant, and cannot be explained by looseness of translation" is a good enough rule for these cases, provided it be strictly construed; but the cases in which it is strictly necessary to suppose a false reading in the Hebrew, in order to explain the phenomena of the Septuagint, are not numerous.

Literature. The articles on the Septuagint in the leading Bible Dictionaries are full, and give the literature of the subject. That in Smith's *Bible Dictionary* is especially elaborate. The *Old Testament in Greek according to the Septuagint*, by Dr. Henry Barclay Swete, Cambridge University Press, is a particularly valuable edition of the text (Vol. I., *Genesis to 2 Kings*, 1887).

(W. J. B.)

SEQUOIA, a genus of coniferous trees, of the *Cupressinæ* or cypress family, their nearest alliance being the *Taxodium*, the bald cypress of the Southern United States and Mexico. They differ from the cypresses proper in having the scales of the cones arranged in spirals, like those of the pines, instead of in pairs, or whorls of three. There are two species only, both remarkable for their size, and both mainly confined to California. *S. sempervirens*, commonly called Redwood, is found only on the Coast Ranges, extending from Monterey Bay into Oregon, but is most abundant

See Vol. XX, p. 673 (p. 705, An. Rep.).

north of the Bay of San Francisco. Here it forms extensive forests, being, with the exception of its related species, the largest of the many immense trees of the Pacific slope region. This species bears small, oval cones, each of the wedge-shaped scales usually containing 5 seeds with wing margins. The leaves, unlike those of the cypress, are spirally arranged on the branch, and densely clothe the twigs with their bright green foliage. The bark of the *Sequoia* is of a peculiar fibrous texture and of great thickness. Externally it is of a rich dark-brown color. *S. sempervirens*, where it abounds, does so almost to the exclusion of other trees, and forms extensive forests. A magnificent spectacle is presented by these forests, extending as far as the eye can reach, of thickly grouped trees 8 to 12 feet in diameter, and 200 to nearly 300 feet high, their trunks of arrow-like straightness, and without a branch till they reach a height of 100 to 150 feet, then spreading into a dense canopy of deep green glossy foliage. Individuals have been observed of from 50 to over 75 feet circumference, and 275 feet high, while there are stories of still larger ones.

The redwood is the most valuable of California timber trees, and is rapidly disappearing before the axe of the woodman. The wood is light but firm, straight grained, of a handsome red color, and polishes well. It is valuable for interior decoration, and as durable as red cedar for posts. The tree is very tenacious of life, old stumps long retaining their vitality, and sending out fresh shoots. It has been tried in the Eastern United States, but does not flourish; yet it grows well in England, where it forms a handsome park tree.

The remaining species, *S. gigantea*, is a tree of surpassing interest, not for its beauty, it being much less attractive in appearance than *S. sempervirens*, but for its immense size, and its position as the unquestioned giant of the vegetable world. This species is still more contracted in range than the former, being confined to the western slope of the Sierra Nevada, and to a range of 2° or 3° in latitude, occurring only between elevations of 4700 to about 7000 feet. It bears small, awl-shaped leaves, paler in color and less graceful in arrangement than those of the coast redwood, its branches are short, and its head of foliage lacks the spreading grace of the other species. The cones are thrice as large, the color of its bark and wood similar, but the latter a duller red. It is much less abundant, occurring generally in detached groves, mingled with other coniferous trees. Its claim to distinction lies in its immense height and bulk. Individuals now stand of 325 feet in height, and there is reason to believe that others known attained from 400 to 450 feet. This height is equalled, and perhaps exceeded, by the giant *Eucalypti* of Australia, but the latter are immensely surpassed in bulk by the "Big trees" of California, some of which are certainly over 90 feet, while others are said to have measured over 100 feet in circumference at base.

The most northerly of the Big trees are two groves in Calaveras county. These were the first known, being discovered in 1852 by a hunter named Dowd, who led a party of miners thither. The earliest scientific description was published by Dr. Lindley in 1853, who named the tree *Wellingtonia gigantea*. The California botanists, with patriotic sentiment, changed this name in 1854 to *Washingtonia gigantea*. Meanwhile Dr. Torrey had obtained some of the flowers, and determined that the tree was of the same genus as the coast redwood, which had been named *Sequoia* by Endlicher in 1847. It therefore has since borne its proper name of *Sequoia gigantea*.

The most important of the Calaveras groves has still four trees of over 300 feet, the tallest being 325 feet high, and 45 feet girth at 6 feet from the

ground. The stump of one which has been cut down measures 23 feet diameter, and 24 feet in one direction. Its rings of annual growth indicate an age of about 1300 years. One tree, 327 feet high and 90 feet circumference at base, was stripped of its bark to the height of 116 feet for the purpose of exhibition. The greatest tree is one which was found prostrated and broken off at a height of 300 feet. At this point it is 18 feet diameter, and is said to have been 112 feet in circumference at base. This, as it tapers regularly, would indicate a total height of about 450 feet.



Sequoia Gigantea.

(Stripped of bark to the height of 116 feet.)

South of this grove are two or three others, but none of special importance till the Mariposa grove is reached, 16 miles south of the Yosemite Valley. There are two patches here, the lower one at a height of 5500 feet. This contains 125 trees of over 40 feet circumference. One, known as the Grizzly Giant, is over 63 feet circumference at base, and

over 64 at 11 feet from the ground. Remains of still larger trees lie on the ground. Many have been sadly injured by fire. The tallest is only 272 feet high, and thus not equal to those of the Calaveras grove. The Mariposa grove has been set apart by Congress as a national park, and is under the charge of a government guardian. About 12 miles south of this is the Fresno grove, which is said to have about 600 trees, the largest being 81 feet in circumference. From this place south to the Tule River the Big trees seem more abundant, and more generally dispersed through the forest. Some trees are supposed to be over 2000 years old, but botanists doubt if this age is much exceeded. The timber of this species is of no great value, though the heart wood, varying from reddish to deep brown, has been used in cabinet work.

S. gigantea, like its congener, *S. sempervirens*, seems to thrive in England. The genus can be traced to a remote geological age, fossil traces of it being found in the older Cretaceous. It is represented by 7 or 8 species in the Tertiary, and seems to have grown all round the Arctic zone, extending in Europe as far south as Greece, and in western America at least to Oregon. One Tertiary species closely resembles *S. gigantea*. (C. M.)

SEQUOYAH, Indian chief. See GUESS.

SERGEANT, JOHN (1779-1852), lawyer, was born at Philadelphia, Dec. 5, 1779. His father, Jonathan Dickinson Sergeant (1746-1793), also an eminent lawyer, had been a New Jersey delegate to the Continental Congress, but settled in Philadelphia before the close of the Revolutionary War. The son graduated at Princeton in 1795, had a brief experience of mercantile life, then studied law and was admitted to the bar in 1799. In 1801 President Jefferson appointed him a commissioner in bankruptcy, and he served some terms in the Pennsylvania legislature. Entering Congress in 1815 he took part in the struggle which resulted in the Missouri Compromise, and thenceforth was closely attached to Clay. He retired from Congress in 1823, but was again a member 1827-29 and 1837-42. In 1826 he was appointed one of the envoys to the abortive Panama Congress and in 1832 he shared Clay's defeat, being the National Republican candidate for vice-president. In 1837 he was chosen to preside over the Pennsylvania Constitutional Convention. Honorable and learned, he was a leader in his profession, and was engaged in the most important cases before the U. S. Supreme Court. His last public service was as arbitrator in settling a long pending controversy between the Federal Government and the State of New Jersey. He died at Philadelphia, Nov. 23, 1852. His *Selected Speeches* were published in 1832.

SERPA PINTO, ALEXANDRE ALBERTO DA ROCHA, a Portuguese explorer of Africa, was born at the Tendões, in Douros, Portugal, April 20, 1846. He was educated at the Royal Military College, Lisbon, and entered the infantry in 1863. He served as lieutenant in the Zambesi war in 1869, and distinguished himself at the battle of Massangans, Nov. 23, where he had command of a native troop. He became major in 1877, and then crossed Africa from Benguela to Durban. His explorations obtained for him high honors from the principal geographical societies of Europe and from the King of Portugal. In 1884 he undertook with Cardoso an expedition for the exploration of the country between Mozambique and Lake Nyassa. Their journey though interrupted by sickness was rich in geographical discoveries, and extended the Portuguese protectorate over many tribes of the interior. In 1887 Serpa Pinto was dispatched on diplomatic missions to East Africa. His chief work is *How I crossed Africa* (1881).

SERRANO Y DOMINGUEZ, FRANCISCO, DUKE DE LA TORRE (1810-1885), Marshal of Spain, was

born at Arjouilla, Andalusia, Sept. 17, 1810. His father, General Serrano y Cuenca, distinguished himself in the war against Napoleon. The son early entered on a military career, and having joined the party of Queen Maria Christina, was by her influence made general at the age of 30. He worked for the downfall of Espartero in 1843 and after the queen-mother's restoration assisted Narvaez in his opposition to Olozaga. In 1845 he was made lieutenant-general and senator and soon after minister of war. After the marriage of Queen Isabella in 1846 Serrano obtained such influence with her that trouble arose in the royal household. The ministry which supported him was overthrown by public indignation. Serrano soon after became a Liberal and in his endeavors to thwart Narvaez, procured the recall of Espartero and Olozaga. He was obliged, however, to accept the captaincy-general of Granada, which withdrew him from the court. In February, 1854, he was implicated in an insurrection at Saragossa and was banished. He returned however in July and supported the O'Donnell-Espartero ministry, until there was a rupture between its leaders. He then took sides with O'Donnell and was made captain-general of New Castile, which put Madrid in his power. He supported O'Donnell in his *coup d'état* of July, 1856, and quelled more than one insurrection. In the next year he was made ambassador to Paris, but the fall of O'Donnell in September occasioned his recall. In 1859 he was made captain-general of Cuba, and his attempts to procure the restoration of Santo Domingo to Spain, though finally abortive, served to obtain for him the title of Duke de la Torre and the rank of grandee of the first class. In the Senate he steadily opposed Narvaez, and in June, 1865, when that minister was temporarily driven from power, Serrano became captain-general of Madrid. But Narvaez returned in 1866 and soon prorogued the Cortes. Serrano, as president of the Senate, presented to the queen a protest against this act as illegal, but was prosecuted therefor by the ministry and for a time imprisoned. When the revolution of September, 1868, drove the queen from the country Serrano hastened to Cadiz and with Gen. Prim seized the direction of the government. He became president of the council of ministers and commander-in-chief of the army. While the modern ideas of human rights and freedom were proclaimed and introduced into the laws, the Cortes decided in favor of a constitutional monarchy in June, 1869. But it was not easy to get a king to take the uncertain position, and on the 16th Serrano was declared regent by a vote of 103 against 45. The Republicans had earnestly resisted the return to monarchy and now rose in insurrection in various places, but the marshal readily overcame them and on Oct. 17th, Valencia, their last stronghold, surrendered. Cuba took advantage of the troubles of Spain to declare its independence, and it was even rumored that the marshal was negotiating the cession of that island to the United States as the shortest way out of the difficulty. But on the contrary the American government by preventing the infringement of neutrality gave the Spanish government time to recover its hold on its most precious possession "the ever faithful isle." A Carlist conspiracy at Barcelona caused alarm, but was overcome. Meantime the offer of the Spanish throne to a Hohenzollern prince was made a pretext for the declaration of war by France against Prussia, with its disastrous results to the aggressor. Finally Prince Amadeus, son of the King of Italy, was elected King of Spain Nov. 16, 1870, and was prevailed upon to accept the throne. During his troublesome reign of fourteen months, Serrano was the most prominent figure, exerting himself in every way to preserve order among the restive partisans, Carlists and Republicans. The latter suc-

ceeded so far that Amadeus abdicated the royal power and the republic was proclaimed Feb. 11, 1873. Serrano, who had remained quiet meanwhile, was on Feb. 27, 1874, appointed president of the executive power and took the field against the Carlists of the north. In May he returned triumphant and received a splendid ovation. In December, however, he again marched against the Carlists, but learning that Alfonso, the son of Queen Isabella, was to be proclaimed King, and believing that this course would restore peace to Spain, he withdrew for a short time to France. On Feb. 1, 1875, he returned to Madrid and soon became a member of the new Spanish Senate. He objected to the terms of the Constitution of 1876, but sought their amendment by legislative methods. In 1882 he proposed the formation of a new party to be called the Dynastic Left. His opposition however gradually subsided and in November, 1883, he was appointed ambassador to France. He died at Paris Nov. 26, 1885.

(J. P. L.)

SETON, ELIZABETH. See CHARITY, SISTERS OF. SEVEN DAYS' FIGHT. See PENINSULAR CAMPAIGN.

SEVENTH DAY BAPTISTS. See BAPTISTS, SEVENTH DAY.

SEVEN PINES, Battle. See PENINSULAR CAMPAIGN.

SEVIER, JOHN (1744-1815), first governor of Tennessee, was born in the Shenandoah Valley, Virginia, in 1744. He was of French Huguenot parentage and was early noted for his agility and daring. In 1769 he joined the party which built a fort on Watauga River, supposing it to be in Virginia territory. In 1773 he was commissioned by Lord Dunmore, governor of Virginia, as captain and took part in an expedition against the Shawnee Indians. In the next year he fought at Point Pleasant on the Ohio. In 1777 he was chosen as delegate from the Watauga settlement to the North Carolina legislature and obtained a district organization and local courts for the territory west of the mountains. His activity in holding in check the Indians whose war-path had been obstructed by the new settlements, endeared him to the whites. Commissioned as lieutenant-colonel in 1779 he punished the Indians severely at Boyd's Creek. Still more important was his leading his hardy followers over the mountains and gaining a signal victory over the well-disciplined loyalists at King's Mountain, Oct. 7, 1780. This stemmed the British progress northward and revived the patriot cause in North Carolina. The legislature therefore acknowledged his bravery by a vote of thanks and a sword. In 1784 however North Carolina made a conditional cession of her territory beyond the mountains to the General Government, and the settlers finding their interests neglected, assembled in convention at Jonesborough, organized a separate State to be called Franklin, and chose Sevier its governor. The North Carolina authorities, roused by this action, retracted their own proposal. They renewed their claims to the territory, and supported some disaffected settlers in their opposition to Sevier and his government. His representatives appealed to Congress at Philadelphia, but they met with little favor. When Sevier's term of three years expired, no election was held for a successor, and the inchoate State lapsed into its original condition. Sevier was still the leading man of the region and was commissioned by Washington in 1790 as brigadier-general of the "Territory South of the Ohio River," which had been formed from the lands relinquished by Virginia and the Carolinas. The part ceded by North Carolina was in 1796 erected into the State of Tennessee, and Sevier was elected its governor. He served for two terms, then retired, but in 1803 was again chosen and served six years more. In

1811 he was elected to Congress and he served on the committee on military affairs during the war of 1812. In 1815 he accepted a commission to negotiate with the Creek Indians and while engaged in this business died near Fort Decatur, Ala., Sept. 24, 1815. His memory is honored by a monument at Nashville. See Ramsay's *History of Tennessee* and J. R. Gilmore's *John Sevier, the Commonwealth-BUILDER* (1885).

SEWALL, SAMUEL (1652-1730), Puritan, chief-justice of Massachusetts, was born at Bishopstoke, England, March 28, 1652. He was brought by his father to Newbury, Mass., in 1659, and was educated at Harvard, graduating in 1671. He remained there as librarian, and studied theology, but his marriage in 1676 with the daughter of the minister, John Hull, diverted him from preaching to become assistant in his father-in-law's business. In 1684 he was made assistant-governor and as such in 1686 he surrendered the colonial charter to Sir Edmund Andros. During his visit to England in 1688-9 the people overthrew Andros' government. Sewall in 1692 was made a judge and also a member of the executive council. In that year he presided at the trial of some of the victims of the Salem witchcraft delusion. A few years later, convinced of his error, he made a public confession in the church, asking pardon of God and men for his offence. His conscience was also touched by the sin of slave dealing, and he published a tract, *The Selling of Joseph* (1700). He was also an advocate and supporter of Indian missions. In 1718 he was promoted to be chief-justice of the colony and held that office ten years. He died at Boston, Jan. 1, 1730. He had published *Answers to Quæries respecting America* (1690); *Accomplishment of Prophecies* (1713); *Description of the New Haven* (1727). For full understanding of his life and times see his *Diary*, edited by Joseph Sewall and published by the Massachusetts Historical Society (1878).

His son, JOSEPH SEWALL (1688-1769), was a fervid orthodox preacher, known as "The Weeping Prophet." He graduated at Harvard College in 1707, and in 1724 was called to be its president, but declined. He had been assistant pastor of Old South Church since 1713, and was a member of the Society for propagating the Gospel in New England. He gave his approval to Whitefield in 1740 and contributed to the support of students at Harvard. He died at Boston, June 27, 1769.

Samuel's nephew, STEPHEN SEWALL (1704-1760), also became chief-justice in 1752, after having been judge of the Superior Court since 1739.

Stephen's nephew, JONATHAN MITCHELL SEWALL (1745-1808), though a prominent lawyer, was more famous as the writer of patriotic and political songs. During the Revolution his "War and Washington" had great vogue. In his "Epilogue" to Addison's *Cato*, written in 1778, occurs the once famous couplet:—

"No pent-up Utica contracts your powers,
But the whole boundless continent is yours."

A collected edition of his *Poems* was published in 1801 at Portsmouth, N. H., where he died March 29, 1808.

Stephen's grandnephew, JONATHAN SEWALL (1728-1796), was a loyalist, and died judge of the admiralty in New Brunswick.

SAMUEL SEWALL (1757-1814), great-grandson of the first-mentioned, attained to the same high judicial position. He graduated at Harvard in 1776, and having engaged in the practice of law at Marblehead, was frequently elected to the State legislature, and in 1797 to Congress. In 1800 he was made judge of the Superior Court and in 1813 chief-justice. He died June 8, 1814, at Wiscasset, Maine, where he had gone to hold court.

SEWERAGE. Until within recent years American sewerage systems have been modelled after European examples and based upon the experience of other countries, using very much the same material and employing the same methods of workmanship. Later experience, however, has shown the need of new methods to meet the special conditions peculiar to certain localities, as, for example, at Chicago, Memphis, and Boston, or in summer sea-side settlements. It has also been found that the data regarding rainfall and population derived from European experience did not apply equally to this country, where the climatic conditions are entirely different, as well as the habits of our people in respect to the more general use of plumbing appliances, fondness for bathing, and the enormous consumption of water for manufacturing purposes.

The rainfall of London averages 24 inches per annum, only one-half as much as that of Boston, while the consumption of water per head in London is but one-third as much as in Boston. Again, the rainfall in America is much heavier than in England, sometimes amounting to nine inches in a single month or two inches in twenty-four hours, in contrast to the "perpetual drizzle" of Great Britain. In Pullman, Ill., the average discharge into sewers from each dwelling amounts to 100 gallons per day. In New York City the total water-consumption per head is nearly as large.

There are still many towns without any sewerage systems, though they have a public water-supply; while, owing to their rapid growth, many other cities have found their sewers wholly inadequate. The population is frequently scattered over large areas, so that the section to be drained is so great that the cost of laying sewers becomes enormous. Again, in most large cities a considerable population of ignorant foreigners who live in tenement-houses are not accustomed to modern sanitary conveniences, and, being careless and filthy in their habits, they throw all sorts of rubbish into drains and sewers, and consequently make the cost of maintenance excessive.

Recent Changes.—The most notable recent developments in American engineering practice have been: (1) In the substitution of much smaller sewers than were formerly used, and having them constructed of such a shape and material, either brick or tile, carefully laid with proper grade and alignment, as to prevent any deposits and to secure a uniform and constant flow of the waste material. (2) In the employment of flush-tanks, where sewers are laid with but slight grade, so placed at their upper ends that they will be thoroughly scoured and kept free from all deposits. The authorities of Paris have lately advised the expenditure of \$520,000 to supply no less than 3166 flush-tanks, to discharge once or twice every twenty-four hours. They have been used with great benefit in many other places, notably in Memphis, Tenn., under the direction of Col. G. E. Waring. (3) In the systematic ventilation of sewers by perforated man-holes, located at the street level, and always kept open. (4) In the use of improved appliances for clearing catch-basins and removing deposits of silt or other material when necessary; and (5) In superintending and regulating plumbers and other mechanics when making connections from buildings with the sewers as a security against careless workmanship.

Formerly sewers were often built of sufficient area to contain a hay-cart or a row-boat; now the preference is given to much smaller conduits, and the cost of construction has been thereby much reduced. According to Prof. Parkes, the total amount of excreta from a mixed population would not exceed twenty-five tons of solid and 91,250 gallons of fluid matter for each 1000 inhabitants, every twenty-four

hours, and as this is delivered into the sewer through the entire day, it can be carried off through a very small drain. In Paris the sewage from a barrack building containing 1000 soldiers was readily conveyed through a four-inch drain. Experiments at Saratoga demonstrated that the entire waste products from a hotel with over 2000 occupants did not fill a six-inch pipe. It is therefore entirely unnecessary and merely a great source of expense to build colossal sewers like the Cloaca Maxima in Rome, and which were formerly deemed indispensable; but sewers are now proportioned to the actual needs of a given locality.

In European practice it is usual to connect house-drains directly with sewers and to allow the former to ventilate through the latter. Where sewers are properly constructed, well laid, and properly ventilated and flushed, there is no objection to this practice. American sewers, however, are so frequently defective from bad construction, breakage, or the accumulation of deposits that it is deemed wise to place an intercepting trap between each house and the sewer with an air-inlet opening at the ground level, and this rule is now generally enforced by all boards of health.

The recent introduction of public steam-heating apparatus in many American cities, and the discomfort and damage caused by constantly turning up street pavements to repair steam pipes, together with the necessity of laying telegraph and telephone wires underground, is steadily preparing the way for the adoption of the Parisian system of laying all sewer, gas, and water mains in an underground tunnel or conduit, where they will be easily accessible without disturbing street pavements, and this improvement will undoubtedly be brought about before long in many cities.

There has been considerable discussion of late in this country as to whether it is best to construct small sewers to receive house-drainage alone, and to make separate provision for rain-water, instead of building sewers of sufficient capacity to receive both forms of waste material. The former method has advantages on the score of economy, and is adapted for localities where there is sufficient grade to the streets to carry off the surface water promptly and where a suitable and safe outfall can be secured. It is charged that large sewers are more apt to be foul from the difficulty of flushing them, that they create more gases, and that they are more expensive both to construct and to maintain. The opponents of the so-called "separate system" claim that surface water will usually be so contaminated as to be unfit for discharging into an ordinary river or stream, and therefore it must be treated as house-waste and removed to a distance. The cost of the two systems of drains, it is claimed, will be greater than one set of pipes, while the rain-water is essential to flush and clean the sewers. Col. Geo. E. Waring has been the principal advocate of the separate system, but conservative engineers like Sir Robert Rawlinson take an opposite view. The general verdict seems to be that no system is applicable to all conditions, and that local considerations must have chief weight in deciding what form of sewerage is to be adopted.

The unsatisfactory results which have followed in London and Paris from discharging the sewage of these great cities into the Thames and Seine rivers have led to the consideration of some other method of sewage disposal, and the irrigation system has been widely advocated instead. Elaborate experiments have been made at Berlin, Edinburgh, and near Paris for disposing of sewage by irrigation. No nuisance has been created and, notwithstanding the popular apprehension, the health of the neighborhood has not been injured, while very extensive crops have been grown on the sewage farms, and have helped to

reduce the expense of their maintenance. Similar experiments have been tried in many English towns with very satisfactory results. The general conclusion, however, has been reached that none of these enterprises can be made profitable and that they must always be viewed as sanitary rather than economical undertakings.

In Great Britain more than 150 towns have introduced the system of sewage disposal by sub-surface irrigation, and the same system has been successfully introduced in the United States though not on a large scale as yet. At Pullman, Ill., with a population of 9,000, most of the sewage is disposed of upon a farm of 140 acres, and the same system has been applied at Lenox, where there is only a small permanent population, and at a number of public and other institutions, as at Lawrenceville, Princeton, and Morristown, N. J., at Sherborn, Danvers, and Worcester, Mass., and at Bryn Mawr, Pa. It has also been utilized at Orange, N. J., and in other places, to drain detached villa residences, and under most conditions has given satisfactory results. It is now proposed to adopt the irrigation system on a larger scale at East Orange, N. J., Brockton, Mass., Los Angeles, Cal., and at Providence, R. I. The latter undertaking will cost in the neighborhood of \$3,700,000, and the result of the experiment will be awaited with interest.

The *Sanitary Engineer* sums up the advantages and disadvantages of the irrigation system as follows: "It would seem that the application of sewage to land, under proper precautions, is the least dangerous and most useful way of disposing of it; that precipitation processes are in some cases useful and even necessary preliminaries to the land filtration; that the disposal of sewage can rarely, if ever, be effected without expense; and, especially, that each case is a problem of itself, to be worked out by a skilled and experienced engineer."

Where a number of towns are situated along a river and discharge their sewage into the stream which is also used as a source of water-supply, as in the case of the Hudson and Passaic rivers, there is great risk of pollution of the drinking supply. A commission appointed by the State of Massachusetts in 1885 has recently presented a plan for draining the valleys of the Mystic, Blackstone, and Charles rivers, and at the same time protect the water-supply of Boston and adjacent towns and cities. The scheme of a united system of drainage for several neighboring towns is considered here for the first time in this country, and it is therefore of special interest. Wherever practicable the sewage is to be carried by intercepting sewers to Boston and discharge into the main drainage system of the latter. For towns too remote from Boston and too far apart to warrant any combination for a sewage disposal, separate areas for intermittent filtration are recommended.

Among the sewerage works constructed of late years in American cities are the following: At Memphis 40 miles of sewers planned by Col. Geo. E. Waring are now in operation at a total cost of \$275,000. Pittsburg, Pa., is said to have over 100 miles of new sewers. At Charleston, S. C., \$230,000 is to be spent on 43 miles of sewerage. At East Orange, N. J., a nearly equal amount is to be expended. Omaha, Neb., has expended \$98,493 on sewers. New York City has increased her sewers within a very few years from 360 to 414 miles. Boston has 200 miles of sewers, just double the area of 1869, and has spent \$2,000,000 upon a great intercepting sewer, which is a model of engineering. The city of Providence, R. I., is considering the expenditure of a large sum for drainage works, upon plans proposed by City Engineer Gray. The Chicago drainage and water-supply commission reports that an

outlay of more than \$30,000,000 will be required, and an annual expenditure of \$2,000,000, to meet the needs of its growing population. Newark, N. J., has spent \$550,000 on a new system of sewers. Albany, Trenton, Newport, New London, Norfolk (Va.), and Baltimore, are all contemplating taking similar action or have actually begun the work. Bar Harbor, Coney Island, Nahant, Atlantic City, Cape May, Asbury Park, and other summer resorts have wisely made provision for drainage and water-supply.

Domestic Sewerage.—Within a few years, and chiefly since 1879, an entire revolution has taken place in the methods of domestic sewerage, and the greatest advance in this direction has been made in the United States. This has been due to the wide discussion of sanitary questions in the press and in official reports, at sanitary conventions and public health associations, and on the lecture platform, together with the interest created by repeated outbreaks of disease traceable to bad drainage, which have sometimes assumed epidemic proportions. It has been accompanied by the passage of laws, in many States, regulating the manner in which plumbing should be executed in new buildings in all large cities and towns, and also requiring that plumbers shall be licensed after passing an examination as to their qualifications. These regulations were first adopted by the cities of New York and Brooklyn, but they have since been widely copied in other places, and as a result great improvements have been effected. A plan of the drainage in all new buildings must now be submitted to the local board of health, and be approved before the work can go on, while the work itself must be subject to inspection during its progress and after completion. As a result, there has been a notable advance both in the quality of the plumbing recently executed and in the intelligence and skill of architects, builders, and plumbers alike.

Hitherto most of the plumbing, especially in buildings in large cities, has been performed under contract for speculative builders and in a reckless manner; such parts of the work as are visible may be properly done, but the hidden and most important portions are usually scamped, so that sickness and death frequently result from the escape of sewer-gas into the dwellings.

Among the most common defects to be found in ordinary dwellings, even of the better class, are the following: Brick or earthenware drains laid underground with imperfect joints, so as to leak into the soil and create foul odors which are liable to rise into living rooms.

Soil pipes constructed of lead instead of iron, so that they sag or are eaten by rats or corroded by sewer-gas at bends or angles; or on the upper side of pipes when laid horizontally, so that foul air may escape without there being any leakage to indicate a defect.

Soil pipes of iron, but with defective joints or lacking in ventilation to the outer air. These pipes are often used as rain-water leaders, and when gorged with rain they cannot serve as ventilators, and foul air is forced into living rooms. Again, they may be connected with chimney flues with a view to securing an upward draught to assist ventilation. In such cases there is danger of sewer-gases penetrating through the cracks in the chimney into living rooms or of a down-draught when the chimney is cold.

Soil pipes connecting with unventilated cesspools or sewers, without any barrier to prevent back pressure.

Insufficient or improper traps, which either become so foul as to be miniature cesspools or lose their seals by siphonage or evaporation.

Refrigerators connected with drains, so that the food-supply is poisoned by foul gases.

Water-tanks with their overflows leading into the cesspools or sewer so as to pollute the drinking supply.

Uncleanly water-closets and other fixtures with deficient water for flushing purposes, and with improper drip-trays, safe wastes, and other connections.

When to these inherent defects, due to ignorance, cupidity, or carelessness, are added the effects of neglect on the part of householders and domestics, the wear and tear of time, and of occasional patching where pipes have become choked or damaged, or where certain portions are abandoned or cut off, a state of things will be found which is far from sanitary or safe. Yet such is the condition of hundreds of houses occupied by the most intelligent and prosperous people. When such buildings, where people may have lived for years without suspicion that anything was wrong, are tested with peppermint, or in other ways, great surprise is manifested at their condition, but the heavy mortality from preventable disease in all settled communities affords ample evidence of the dire effects of so much bad plumbing.

Under the rules and regulations now enforced by boards of health the following features are insisted upon in all the plumbing of new dwellings:

1. The materials must all be of the best; extra-heavy cast-iron pipe, tarred inside and out, and lead pipe and sheet lead of proportionate weight and thickness.
2. All pipes and drains must be concentrated as far as possible, so as to be easily accessible for examination, and so far as possible open to view, the drain pipe in the cellar being carried along the side wall wherever possible and not underground.
3. All joints must be carefully calked with lead, and it is now becoming customary to test them by water-pressure, or with an air-pump, to insure that there are no flaws or leaks.
4. In each house the drains must be disconnected from the sewer or cesspool by a running trap with an opening for foot ventilation carried to the ground level or the edge of the sidewalk so as to create an upward current through the soil pipe, which must be carried up through the roof of full size and usually with the upper end enlarged and left wide open without any cowls, caps, or return bends, but simply protected by a wire basket strainer.

No soil pipe should be used as a leader or connected with a chimney.

Each and every fixture must be separately trapped by an S- or P-trap placed as close to the fixture as possible and ventilated as a security against siphonage by a back-air pipe of ample size connecting at the crown of the trap. All water-closets must be flushed by a separate cistern, and not connected with the same pipes which supply the inmates with drinking-water, nor must any tank overflow or any refrigerator connect directly with a drain. Where the water does not rise at all times to the upper fixtures in a house, then a tank must be provided with a pump to keep it filled.

The English practice of using lead soil pipe has been entirely abandoned in the United States, while the custom of carrying soil pipes outside the building and of separating the drainage from baths and basins from that of water-closets and conveying it in a distinct waste pipe has not been deemed necessary here.

The regulations enforced by boards of health do not affect the choice of fixtures in houses. Great improvement, however, has been made in this direction. With the remarkable advance in the design, decoration, and furnishing of modern dwellings, due to the recent rapid growth in æsthetic taste, there has been a proportionate improvement in the line of

plumbing fixtures. Lavatories and bathrooms are now constructed in the most costly and luxurious manner, the floors and walls being covered with tiling, heavy porcelain-lined baths exposed without superfluous wood-work, and the water-closets and basins fitted up in a most elaborate manner with brass pipes, marble flooring, nickel-plated traps, and other fittings of the most elaborate description. The kitchens and laundries in many private and public buildings are no less expensively furnished, with porcelain sinks and wash-tubs and with the walls and floors protected from moisture by marble or tiling, so that it may be said that modern plumbing has become an æsthetic art as well as a science.

(C. F. W.)

In this connection it may be stated that two new styles of water-closets (both American inventions) have recently been introduced—the "Wash-out" and the "Tip sanitary closet." The former consists in a receiving bowl connected by an S-trap with the soil pipe without valves or moving mechanical parts of any kind. Water is supplied from a tank placed high above the closet, which, coming down with a rush, carries everything before it through the trap and into the soil pipe. Being made of one piece and devoid of all forms of pan, valve, plunger, and siphon attachments it cannot get out of order and is an improvement on former inventions; it requires a large amount of water, which is probably no great objection when the city supply is abundant. The "Tip sanitary closet" is a new departure, or an old one revived. It consists in a receiving bowl and reservoir balanced on trunnions over a hopper; both bowl and reservoir are automatically filled with water from a storage reservoir over the closet and are in one piece, separated by a low water-fence or dam. The receiving bowl is narrowed in front and opens, spout-shaped, into a detached hopper and trap through which its contents are discharged into the soil pipe whenever the closet is "tipped," which can be done by pressing on a stirrup beneath the foot. The water at the back of the receiving bowl, which is regulated by a ball-cock, follows the previous contents of the bowl when tipped and cleanses it of any remaining impurities. The claims made for this closet are saving of water, noiseless action, and simplicity of construction, the only mechanism being the ball-cock and trunnions for tipping.

The ultimate disposal of sewage, including street sweepings, ashes, garbage, and kitchen waste, is now receiving the earnest consideration of sanitarians, and although no plan has yet been perfected, scientific experiments are being made throughout Europe and the United States with a view to destroying by fire, or its equivalent, all refuse of cities. In 1870 Paddington, England, first experimented with a "garbage destructor," which proved a complete failure; a few years later Manchester attempted a similar enterprise, with little better success, though in later years it has accomplished much in this direction. Birmingham, in 1877, met with like reverses at first. Bradford was more fortunate with the "Healey Patent Destructor;" but the one most successful, now in use in England, is the "Beehive Destructor," which was first introduced in Richmond, England, and is now extensively used in that country. In the United States, the first "crematory" for the destruction of garbage was constructed at Governor's Island, New York Harbor, in 1885, for the purpose of disposing of the waste material of the post. Allegheny City, Pa., followed, the same year, with a small "destructor." Two years later a small furnace was built for the use of Johns Hopkins University, Baltimore, Md. Probably the first extensive "destructors" were the "Engle patent," put up at Des Moines, Iowa, and the "Forristal furnace," erected at Milwaukee, Wis., in 1886. The "Rider garbage furnace" followed, the next year, at Pittsburg, Pa., and the "William Mann patent" was erected at Chicago about the same time. In 1888 Minneapolis, Minn., adopted the "Engle patent," with improvements, and was followed by Milwaukee, Wis., and Coney Island, N. Y.

Dr. S. S. Kilvington, president of the board of health of Minneapolis, in speaking of the four principal crematoria which have been in use during the

past three years in the United States, says: "The Forristal furnace, which has been operated until recently in the city of Milwaukee, consists of a two-story building. Teams drive into this building and dump their loads into a hopper, from whence it is carried by elevators into the drying-room above. Here it is treated by steam-heat, and the liquid residue is drained off. It is then shovelled through a tubular shoot to the floor below, where it is deposited in front of the furnace doors. Thence it is shovelled into the fire, and kept constantly stirred. The fire itself is operated on the principle of a blacksmith's forge, with the aid of a blast fan. The latter, together with the refuse-elevators, is run by a small steam-engine, which also furnishes steam for the drying-room. The furnace is of brick, with square form and arched top. It contains a single fire, which is relighted every day. A single row of doors on each side of the furnace serves for the admission of fuel, for the supply of refuse, and for stirring or stoking the fire. Smoke and gases are carried out directly into the chimney shaft. An engineer and four laborers are required to run the plant."

The "Rider garbage furnace" has been largely used in Pittsburg for the destruction of spent tannin and has performed this task, as also that of the destruction of garbage, to the apparent satisfaction of its owners and the public. Its construction requires the primary investment of a large sum, but its patentee claims for it great economy in the expenditure of fuel, of which it is said to require an amount equal to less than five per cent. of the material cremated, this being used as an initial supply to bring all parts of the furnace to a proper temperature; after which it is claimed that the garbage itself, if furnished in sufficient quantity, will provide all the fuel necessary to maintain its operations. This furnace consists of a front chamber 12½ by 6½ feet, which is surmounted by a dome containing 8 circular openings, 15 inches in diameter. In the rear of this is another chamber, 9½ by 6½ feet, floored with a tile hearth and separated from the first chamber by a bridge wall, 3 feet in thickness, and having in its rear a second bridge wall over which the products of combustion pass to enter the chimney. The second chamber is also surmounted by a dome in which are 6 circular openings, of the same size as the first. The products of complete combustion are said to be innocuous, while the solid residue is valuable as a fertilizer.

The "Mann destructor" shares with the Engle patent the beauty of simplicity of structure. As built in Montreal, Canada, where its operations are reported as being very satisfactory, its combustion chamber is quadrilateral, with dimensions 16 by 9 feet, and 10 feet high. This is fitted with a grate of approximately same dimensions, laid with a slight incline upward in the direction of the chimney-flue. At the lower end of this grate is its single fireplace. On each side are three tiers of three doors each; the upper tiers are at the level of a staging floor upon which the loaded refuse-carts are driven, the refuse being emptied directly into the furnace through these doors, or placed upon the floor in front of them. The second tier of openings is situated just above the line of the grate, and these are used for stirring the fire. The lowest tier is at the level of the ash-pit and are for the removal of the ashes. The grate bars are two inches apart.

The "Engle crematory" has a brick chamber 33 feet long by 5 feet wide, and 7 feet high from grate to dome; at the end of the furnace grate nearest the chimney, but not opening into it, is the primary fireplace; at the further end of the furnace grate, and communicating with it, is a second grate four feet below the level of the primary one. Here a sec-

ondary fire burns, and with it the chimney flues are connected by a superheated tiled roof conduit, running beneath the primary fire-grate for a length of 28 feet to the chimney shaft, 100 feet high. The building in which the furnace is enclosed is three stories in height; at the level of the first floor is a double row of doors, the upper of which is used for feeding the primary fire and for stoking the burning material, while the lower opens into the ash-pit and permits the removal of ashes. On the same floor, at the farther end of the furnace, are doors for supplying the secondary fire and removing its ashes. The second floor is on a level with the top of the brick furnace, and upon this floor the bodies of dead animals are delivered through a large tubular shaft, by means of pulley attachments, to the furnace below near the primary fire. The third floor is on a level with three tubular shafts, 15 feet in length, rising from the dome of the furnace and into which the miscellaneous refuse-wagons immediately discharge their contents from the upper floor upon which they drive. The capacity of this furnace is very great, and the expense of operating is said to be very moderate. Three men operated it five days, consuming 33 horses, 59 dogs, 103 barrels of hotel and commission house refuse, 12 loads of market offal, and 70 loads of manure, weighing in all over 200 tons, at a cost for labor and fuel of \$38 25, or 19 cents per ton. An analysis of the ash from this crematory demonstrated that it was valuable as a fertilizer.

The most recent and novel invention has lately been erected in Buffalo, N. Y., and is called a "garbage extractor." It is thus described by Dr. Edward Clark, health officer of that city, who says it is a wonderful piece of mechanism: "The garbage is first of all put into dryers, which consist of a large iron cylinder within a cylinder; the space between the two cylinders is filled with superheated steam, which drives over 60 per cent. by weight in the shape of moisture and organic gases from the garbage. The internal cylinder contains a number of revolving arms, filled also with superheated steam; these arms keep the garbage constantly stirred, so that all moisture is driven off at a temperature of over 300° F., and by means of a powerful suction fan is forced into a column condenser from which it emerges as a perfectly clear and odorless water. After the moisture is all driven off, in the form of a distillate, the dryers are emptied of their contents, and instead of resembling garbage the mass looks like soft brown earth containing a certain quantity of grease. It has very little odor. This mass is then elevated into what is known as the 'extractor,' where, by means of a chemical solution, all the grease is extracted and drawn off into barrels. This, of course, has a commercial value. The residue is then taken from the extractor and used as a fertilizer, after removing all the pieces of bones, glass, iron, rags, etc. The final product is perfectly dry, free from oil and odor, and no more offensive than dry earth, which it very closely resembles."

It would seem, from the description of the various kinds of "cremators," "destructors," and the "extractor," that the disposal of all manner of sewage is in process of being solved without the use of drain and sewer-pipes. House and hotel crematories are also coming into use quite extensively in the larger cities, and some families even depend upon their kitchen range to destroy the greater portion of the garbage and kitchen refuse, rather than rely upon the uncertain movements of the garbage collector, while the dry earth or ashes and the pail-closet system of disposing of excrement emphasizes the practicability of dispensing with the dangerous water-closet and sewer-pipe.

Dry-air Closets.—Another system of disposing of fecal and urinary deposits is rapidly coming into

favor. This is known as the "Smead system of dry-air closets." It consists in passing the dry air of a properly ventilated house through the closets and into a ventilating shaft. The manner of doing this is unique and the result is remarkable: A "down-draught" from the various rooms in the building, created by flues connecting with a heated ventilating shaft outside, carries the vitiated air of the ventilated rooms into a "gathering room" which communicates directly with the closets and thence with the shaft—the fecal and urinary deposits are thus subjected to a constant current of dry air, which not only destroys all odor and evaporates all moisture but renders the night-soil so dry and earth-like as to no longer resemble fecal discharges; it can then be burned where it lies or used as a fertilizer. Many school-houses throughout the United States are supplied with this system of "sewerage," thus dispensing entirely with water-closets, the tests having proved satisfactory both in winter and summer.

(P. H. B.)

SEWING-MACHINES.

See Vol. XXI
p. 718 (p. 754
Am. Rep.)

Of modern inventions there are few of more importance, or that have done more for the comfort and convenience of civilized communities than the sewing-machine. In its various applications to the making of clothing, shoes, etc., it has greatly added to the abundance and cheapness of these necessities of life, and aided in enabling the poorest of the laboring classes to dress warmly and respectably. The sewing-machine is usually claimed as an American invention, and justly so, if regarded as an effective instrument, though the idea originated in England, where efforts at machine-sewing were made as early as the middle of the last century. No satisfactory English machine was produced, however, though that of Thomas Saint (1790) possessed many of the features of the successful modern machines. A French inventor, M. Thimonnier, produced in 1830 a machine which worked with some efficiency, and was patented, in an improved form, in the United States in 1850. America, however, has the honor of producing the first practicable machines for sewing cloth and leather. The Rev. John Adams Dodge, of Monkton, Vt., invented, in 1818, a machine which, like the earliest English machine, used a double-pointed needle with the eye in the middle. It made a back stitch, and sewed a good seam straight forward, but would not let the cloth be turned. This machine was not patented, and the professional duties of the inventor forced him soon to abandon his experiments.

The earliest effective machine of the modern pattern was invented in 1832 by Walter Hunt, of New York. It was the first machine to use two threads, one being carried by a curved needle, with the eye in the point, the other by a shuttle. It formed what is known as the lock stitch. Other inventors followed, from time to time, and in 1846 Elias Howe, of Cambridge, Mass., took out a patent for a machine which was in its more important appliances similar to the unpatented Hunt machine, though with several novel devices. This is looked upon as the parent sewing-machine, all the more recent inventions being, in the main, simply improvements upon it. It had defects which the inventor did not succeed in overcoming, and which prevented it from working satisfactorily and being accepted by the public or by capitalists. These defects were removed by later and better mechanics. John Bradshaw, of Lowell, Mass., patented in 1848 a device to regulate the tension. Others improved the feeding arrangement, and still others invented a lock stitch differing from Howe's, though the same in principle. The lack of a satisfactory feeding device, a defect in all the earlier machines, was overcome in 1850 by the effective four-motioned feeder invented by Allen B.

Wilson, of Pittsfield, Mass. His machine also replaced the shuttle by a rotating hook device. Other machines quickly followed. That of Isaac M. Singer, the first that proved satisfactory to manufacturers, is said to have been produced in 12 days' time on a promise to make an efficiently working machine for \$40. In 1851 William O. Grover, of Boston, invented a machine that made a double loop stitch by means of a circular rotating needle. All these machines used the leading features patented by Howe several years before, and a lawsuit arose which ended in his being paid a royalty on all machines manufactured. This royalty continued in force till 1867, and brought him in nearly \$2,000,000. Singer, by obtaining control of other patents, accumulated a large fortune.

The Weed, the Florence, and other new machines came into the market about 1854, the Willcox & Gibbs in 1857, and since that period the application for patents for sewing-machines and devices connected therewith have averaged about 50 per year. The last mentioned, invented by James E. A. Gibbs, of Millpoint, Va., is the most popular of the single-thread machines. It makes a twisted loop stitch by means of a rotating hook under the cloth, and, having the advantages of noiselessness, speed, and ease of running, has sold largely. Of the more recent machines we may name the Remington, Domestic, American, and two Howe machines (the Elias and the Amasa B. Howe). An important event occurred on the 8th of May, 1877. At noon of that day the last of the essential patents held by the sewing-machine manufacturers expired, and the devices necessary to the making of a workable machine were open to all. Prices at once fell 40 or 50 per cent., the \$60 machine being reduced to \$30, and the \$70 to \$40. This was a highly desirable result to the general public, and has greatly added to the number of machines in domestic use. The Wilson feeder was the most important of the expiring inventions, others being the vibrating needle, the reciprocating shuttle, and the rotating hook. There are perhaps a thousand patents still in force, but the above-named were the foundation patents, without which no first-class machine could be made. In addition to the patents for machines, many have been taken out for devices necessary to perform certain kinds of sewing, such as basting, folding the cloth for hemming, button-hole making, etc. Some of these devices are remarkable for the intricacy and accuracy of their achievements, and machine work is now done of a character that would seem impossible to be performed otherwise than by hand. By the use of the sewing-machine, sewing can be done with at least five times the rapidity of the fastest hand-sewing, and with greatly decreased labor. The treadle motion, which has hitherto been the most exhausting part of the work, is being avoided by the use of steam, and by spring and electric motors suitable for house use, which, when generally introduced, will be a great saving of labor. It is questionable if much further improvement can be made in the efficiency of the sewing-machine; it is almost perfect in its running and its performance now, and is a notable example of the great advance in modern machinery.

In addition to the machines in use for ordinary sewing, there are many inventions adapted to the performance of special work which in some cases is seemingly beyond the power of machinery, yet is done with extraordinary accuracy and rapidity. A very important one of these is the cylinder sewing-machine, which possesses a cylindrical feed arrangement adapted to sew seams on sleeves, water-hose, leather buckets, boot-legs, and similar cylindrical articles. It is adapted for all grades of shoe-work, but especially for vamping, and is also used largely by manufacturers of gloves, pocket-books, travelling

bags, and many other articles of this general character. Other machines adapted to special work are the carpet sewing, the book sewing, the shoe sewing, the sail making, etc. The most useful among these are the shoe-sewing machines, their importance being almost equal to that of the ordinary cloth-sewing machines. By their aid

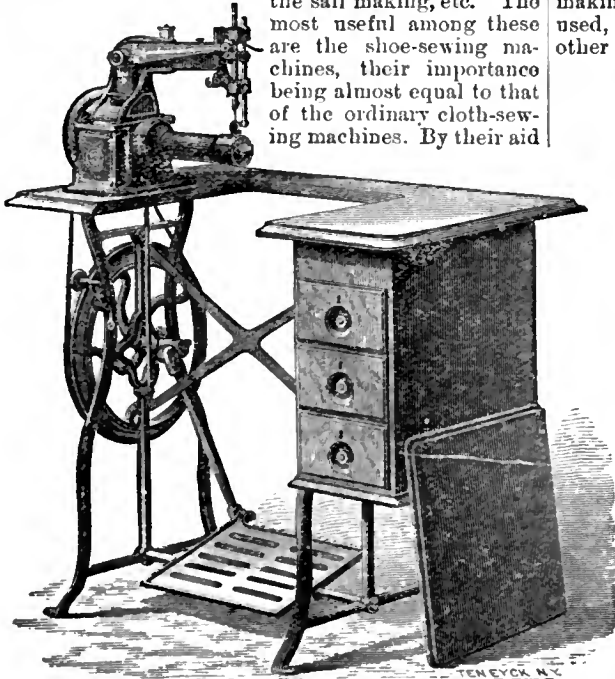

Cylinder Sewing-machine.

and the special button-hole stitch. The lock-stitch is made by all shuttle machines and by those employing a rotating or revolving hook. Of all stitch-making devices the shuttle is now most extensively used, though it is replaced in some machines by other devices yielding the same general result. In

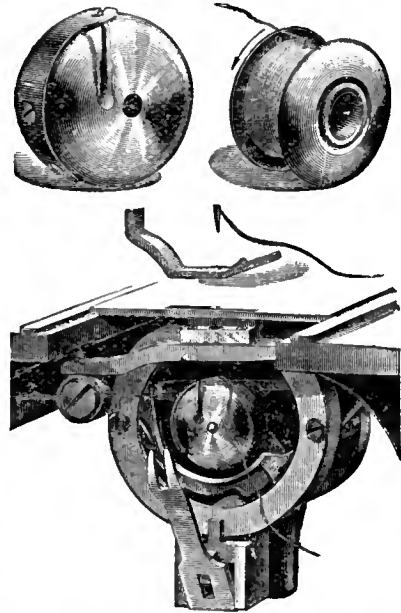

Bobbins and Bobbin-attachments.

many millions of boots and shoes are annually produced, with a cheapness and rapidity unapproachable by hand-work. Of the various machines used in this industry the McKay, invented about 1858, is that principally employed. For statistics of the factory work produced by the aid of these machines, see article, SHOES.

Another instrument of remarkable character is the automatic button-hole machine, of which we give an illustration. There is no department of sewing-machine work in which greater progress has been made. A few years ago it was considered an excellent performance to make 1000 button-holes in a day of ten hours by machine labor, yet to-day from 3000 to 6000 holes per day can be made—the number varying with the fineness of the stitch and length of the button-hole—and with less fatigue to the operator than in the old process. The machine here illustrated is an instrument of almost magical efficiency. It can be run to make from 1000 to 1200 stitches per minute; it will make a straight button-hole of any length up to one inch; it cuts the hole in the material, winds its own bobbins, stitches or cords the hole as desired, and stops automatically, without aid from the operator, when the stitching is completed. It seems almost possessed of conscious intelligence.

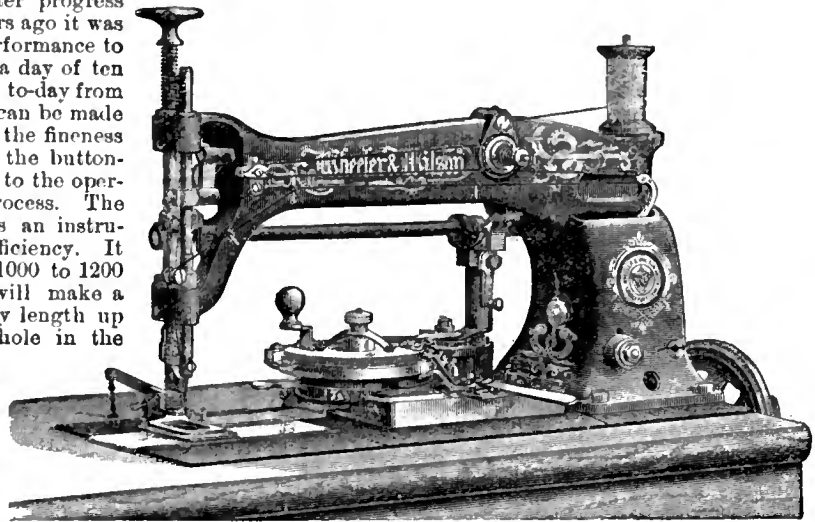

Button-hole Machine.

Various stitches have from time to time been used in sewing-machine work, but at present the lock-stitch is employed in fully four-fifths of all machines made. Of other stitches now employed may be named the Grover & Baker double loop, the Willcox & Gibbs single chain,

the Wheeler & Wilson, for instance, the bobbin is made to do the duty of the shuttle, and presents the advantage that the lower and upper parts of the machine can be driven at the same speed, instead of the lower having to be driven at double speed, to achieve the backward and forward movement of the shuttle. The figure above gives an illustration of this bobbin, the case in which it is confined, and its position in the machine. It is capable of holding "over 100 yards of No. 70 cotton, having about twice the

capacity of the largest bobbin heretofore in successful use in any lock-stitch machine."

The United States is much the largest producer of sewing-machines in the world, no other country having so many or so large factories. Some of these

factories, as the Singer, the Wheeler & Wilson, and the Howe, are of great extent, and turn out annually vast numbers of machines. As to the number of sewing-machines made, we have no record previously to the "Albany agreement" of 1856, but from that year to 1869 the sales amounted to 1,500,000 machines. From 1869 to 1878 the sales were 4,800,000, making a total of 6,300,000 machines, worth \$360,000,000, produced in the United States in 22 years. In 1880, as per the census returns, there were 106 establishments in operation, with a total capital of \$12,501,830, and an annual product of machines valued at \$13,868,188, and of cases valued at \$2,064,837. This is below the average of the 22 years preceding, but is based on a fall in price of nearly 50 per cent., so that the number of machines sold must have been considerably above that average. In the manufacture of sewing-machines only the finest material and the best workmanship are employed, and the interchangeable system is carried out to the fullest extent, the parts of the cases and the smallest parts of the machine being made exactly of the same size and pattern, so as accurately to fit in all work turned out from the same factory. This interchangeable system of parts is an American idea which is now widely adopted, and saves vast labor and expense in repairing fire-arms, watches, sewing-machines, etc., there being no longer occasion to return a broken instrument to the factory for repair, as of old. Some of the large factories perform the whole process of making cases, needles, and machines, even owning their own forests, and getting out the raw material of their operations. They have also extensive transportation facilities, and ramifications of sales agencies throughout the world.

The work on sewing-machines, at first, was comparatively coarse, but there has been a continual improvement in this respect, and these machines now rival fire-arms in accuracy of workmanship. Family machines are manufactured "which will make over 2000 stitches a minute, which will sew 600 stitches a minute with No. 60 cotton, using the same cotton as a driving belt for the machine, and which will sew either the finest gauze and tissue-paper or many thicknesses of the heaviest goods, such as leather, heavy duck, beaver, and even tin, and will execute other work requiring a combination of delicacy, accuracy, easy action, strength, and speed probably unapproached by any other class of ordinary machines." Sewing-machines are ordinarily tested, both by sewing muslin and by sewing several thicknesses of duck or beaver. As to their accuracy, it is said that "cams, which in 1870 were machined with a variation from exactness of .0015 inch, are not now allowed a discrepancy of .0005 inch," and that the work which was formerly coarse, as compared with gunwork, is now sometimes the more accurate of the two, this being the result of many improvements, not only in the design of the mechanism but in the accuracy of the machine tools. The development of the sewing-machine, in fact, is one of the most remarkable achievements of American inventive genius. (C. M.)

SEYFFARTH, GUSTAVUS (1796-1885), a noted Egyptologist, passed the last twenty-nine years of his life in the United States, and was during these years probably the most conspicuous representative of his department in America. He was born at Uebigau, near Torgau (then in the electorate of Saxony), July 13, 1796, the son of a Lutheran clergyman. Having received a thorough classical training at the famous "Fürstenschule" of St. Afra, at Meissen on the Elbe, he entered the University of Leipzig. Besides divinity, he studied not only philology and philosophy but acquired wide knowledge in various scientific departments. He gained the degree of Ph. D. and later of D. D. Having finished his academic course, he fitted himself for the career

of an academic teacher, and in 1823 received permission to lecture as *privat-docent*. One of his earlier elaborate works, *De Sonis Literarum Græcarum*, etc. (1824), was honored with an introduction written by the renowned Gottfried Hermann. The only Egyptologist of note at Leipzig in those days was F. A. W. Spolin, and when he died, in 1829, Seyffarth was intrusted by the university with the continuation of his researches. This commission suggested to him the necessity of going more deeply into the subject. Consequently, in 1826-28, he made a tour of the principal museums and collections of Europe, to study and copy on the spot the most important Egyptian papyri and kindred archaeological remains. He visited Berlin, Vienna, Munich, Turin, Milan, Venice, Leghorn, Florence, Rome, Naples, Paris, London, Leyden, Amsterdam; he filled fourteen folios with copies of exquisite perfection (which he subsequently bequeathed to the Historical Society of New York). His method of interpreting hieroglyphs was fundamentally different from that of Champollion. Seyffarth held that the hieroglyphs designated the consonant elements of a syllable; e.g., *kil* (sacrifice), might be designated by a basket (*kah*), the image of an owl (*mulak*) could be read as *melek* (king), whereas Champollion taught that the hieroglyphs were symbols standing for definite letters of the alphabet. A few years after his tour, Seyffarth was made professor extraordinarius of archaeology (at Leipzig), and held this position from 1830 to 1854. He did not succeed, however, in gaining academic followers of distinction, for Lepsius, Brugsch, Müller of Göttingen, Ebers, and others followed the system of Champollion. Uhlemann and Wuttke were the most noted of his own adherents. After 1840 he began to experience great difficulty in finding avenues for publication. Academic advancement also seemed to be cut off.

As a Biblical scholar Seyffarth was uncompromisingly conservative, and underlook in all chronological questions to fix date to the day. He had developed the idea that all the chief deities, not only of the Greek Olympus but also of other pagan systems, were to be derived from the seven planets and the twelve constellations of the zodiac, and that the position of the planets at certain dates was designated on many monuments of antiquity, thus affording data for chronological computation. He taught also that the Hebrew alphabet of twenty-five letters was not only the invention of Noah, that it contained a representation of the zodiac and of the seven planets, but also that the Hebrew was the mother tongue of human speech. Vast as was the erudition of Seyffarth, these extreme chronological speculations and assertions, coupled with the abstruse and involved character of his presentation, as well as his uncompromising hostility to Champollion's system, tended to isolate him more and more from kindred scholars. Finally he took a step which he had contemplated for a number of years—he resigned his position at the University of Leipzig in 1854, and two years later came to the United States. For three years he was professor in a Lutheran theological seminary, the Concordia College at St. Louis. In 1859 he severed his connection with this institution, induced in part by his uncompromising hostility to alavery. Thereafter, with the exception of a few years' sojourn at Dansville, N. Y., where he made a vain effort to establish a Lutheran theological seminary, he made New York City his residence, determined largely by the desire to avail himself of the Astor library and other literary facilities. He wrote very many papers and larger works during this period, largely relating to biblical chronology. Of these many were published in Lutheran periodicals, others in the *Transactions* of the St. Louis Academy of Science; he was also an active member

of the American Oriental Society. Some of his last labors were concerned with the interpretation of the hieroglyphs on the obelisk in Central Park, New York, erected there in 1881 by Commodore Gorringe through the munificence of Mr. Wm. H. Vanderbilt.

In the winter of 1881-82 Seyffarth, then in his 86th year, delivered a lecture on this subject in a public hall, speaking for nearly three hours. This excessive exertion, undertaken against the advice of his friends, caused the bursting of a blood-vessel in his brain. This misfortune incapacitated the aged scholar for all work and soon deprived him of many of the normal faculties. To this was added rapid deterioration of his eyesight, so that during the last three years of his life he was a physical wreck. He died in New York, Nov. 17, 1885, and was buried in the Lutheran cemetery on Long Island. The words chosen by himself for his epitaph from Horace are characteristic:

Multa fecit tulitque puer, sudavit et alsit.

(E. G. S.)

SEYMOUR, HORATIO (1810-1886), twice governor of New York, was born, May 31, 1810, in Pompey township, Onondaga Co., N. Y. His father, Henry Seymour, had moved thither from Litchfield, Conn., as one of the earliest settlers. His childhood was spent in Utica, and he was educated at Geneva College and at Capt. Partridge's military school. In 1832 he was admitted to the bar, and, as his father had belonged to the "Albany Regency," he was soon active as a Democratic politician. Besides the estate he inherited, he obtained a large fortune by his marriage to Miss Mary Bleecker. He was elected to the State Assembly in 1841, and in the next year was mayor of Utica. Returning to the legislature, he was elected speaker in 1845 as candidate of the "Hunker" faction. In 1850 he was Democratic candidate for governor, but was defeated by Washington Hunt, the Whig competitor. In 1852, however, he overcame Hunt for the same position, but having during his term vetoed a prohibitory liquor law, he was in 1854 defeated by the Whig candidate, M. H. Clark, whom the Prohibitionists had indorsed. Seymour was influential in the councils of the Democratic party during the years preceding the civil war, always urging a policy of overtures and concessions to the South. When war was begun he was active in sending New York troops to the conflict, and soon after he was elected governor, in 1862, was thanked by Secretary Stanton for his services. But soon the more vigorous war measures of the national administration encountered his opposition. In New York City, when troops were drafted in July, 1863, a riot broke out, and the mob drove off the Federal officers, overpowered the city authorities, killed some negroes, and destroyed much valuable property. Gov. Seymour endeavored to allay the passion of the mob, and made some effort to enforce order, but the riot was only quelled by the arrival of veteran troops from Washington. In 1864 Seymour was president of the Democratic National Convention at Chicago, which declared the war a failure, but he was defeated for re-election as governor in November of that year. He presided also in the next Democratic convention in New York City in 1868, and was eventually nominated by it for the presidency; but though his

ticket obtained over 2,700,000 popular votes, in the electoral college he received but 80 votes, and Gen. Grant was elected by 214. He declined thereafter to be a candidate for office, but, owing to his wealth, culture, and genial manners, still exerted powerful political influence. He was also active in the promotion of agriculture, education, and philanthropy. He was president of the National Dairymen's Association, and delivered many valuable historical addresses. He died at Utica, Feb. 12, 1886.

His uncle, HORATIO SEYMOUR (1778-1857), was born at Litchfield, Conn., May 31, 1778, being son of a Revolutionary soldier. After graduating at Yale College and studying law, he removed to Vermont and settled at Middlebury in 1799. He was a member of the council, 1809-17, U. S. senator, 1821-33, and in 1847 was made judge of probate. He died at Middlebury, Nov. 21, 1857.

SHAD. The fish commonly known by this name is a member of the *Clupeida*, or herring family, and is classed by the more recent writers in *Clupea*, the herring genus, though for many years past it has been separated as a distinct genus, *Alosa*, on account of certain peculiarities of form. The herrings have the body scaled, the head naked, are destitute of barbels, and of the adipose fin of the *Salmonida*, though they have many points of analogy to the latter. The shad is distinguished from the herrings by having a deep notch in the middle of the upper jaw, and by the lack of teeth on the tongue and roof of

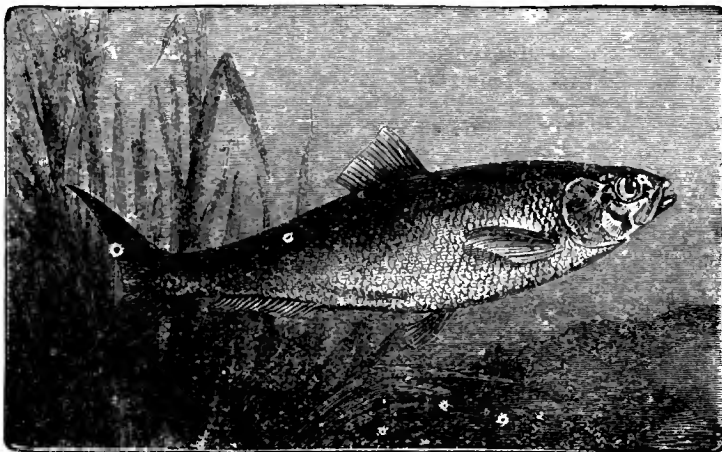

The American Shad.

the mouth. The teeth are small and deciduous, occurring in the jaws only; the air-bladder is simple, opening from the stomach. There are, in all, over 20 species, of which the only ones of much commercial importance are *Clupea (Alosa) sapidissima*, the American shad, and *C. Reeresii*, the Chinese shad, a highly esteemed food-fish of China. There are two common European species, *C. vulgaris*, which is found in all the principal rivers, but is little esteemed as food, and *C. flata*, with which the American shad was formerly thought identical, but which has little commercial value.

The American shad, on the contrary, is one of the choicest and most esteemed of food-fishes, and ranks highest, in the estimation of many, among American fish. It is about 20 inches in extreme length, and averages about 4 lbs. weight, ranging from 2 to 6 lbs. The maximum weight at present is about 8 lbs., though shad were formerly caught of from 12 to 14 lbs. weight. Overfishing has caused a steady reduction in size and numbers. This species is of a bluish hue on the back, shading into a coppery color on the upper and a silvery hue on the

lower sides, while the abdomen is pearly in hue. The quadrangular dorsal fin shuts into a groove, and the anal is partly received in a groove. The pectorals and ventral are small; the caudal, deeply forked. The scales are large; the abdominal ridge, serrated.

The shad is found all along the Atlantic coast of the United States, from the Gulf of St. Lawrence to St. John's river, Florida, and is found everywhere within this range in sufficient quantities to make the fisheries valuable. It is not found native in the rivers that empty into the Gulf of Mexico, though recent efforts to artificially stock those rivers have met with some success. The same is the case on the Pacific coast, where artificially propagated shad have been introduced into some of the streams.

In its migratory habits the shad resembles the salmon, though it probably does not venture so far from the coast, and is supposed to be generally distributed along the coast regions of the ocean at all times. Its feeding grounds and food are probably much the same as those of the salmon. As soon as the river temperature is sufficiently high, the shad enter the streams on their spawning run, appearing in the rivers in the latitude of Charleston as early as January, and successively later up the coast until the middle of May, when they are found in the Bay of Fundy streams. The mature fish return to the ocean in August, the young in September, they being then 3 or 4 inches long. The shad is of rapid growth, and some suppose that it does not survive beyond its second year, though this is not known. The general theory that the shad always returns to the river of its birth is also speculative. It has simply some probabilities in its favor. One thing, however, seems certain, that the shad eats nothing during its river run. The stomach is invariably found empty. Yet the instinct for food is merely overcome by the stronger reproductive instinct, and the shad will occasionally rise to a fly, and afford exciting sport to anglers. The eggs of the shad number from 20,000 to 40,000, and occasionally as high as 100,000. In former times the spawning took place in the head waters of the rivers, but artificial obstructions now prevent the shad from reaching their former grounds, and the eggs must be laid lower down the streams. The mature fish return to salt water after spawning, though some seem to remain in the rivers until late in the season, and have been taken in the autumn months. The new-born shad is said to swim vigorously as soon as it breaks the shell, and to make its way at once to the mid-stream where danger from its foes is reduced. This habit gives it a better chance for survival. The young feed on small crustaceæ and insect larvæ in fresh water, and, unlike the salmon, make their way with considerable haste to the sea.

The shad is caught in drift and seine nets in the Delaware, Hudson, and other rivers, and in these localities is eaten fresh, its flesh being of delicious flavor, though the numerous small bones are a detriment. The fishery is of considerable importance in the rivers of the British Provinces, where the bulk of the catch is salted. In most of the coast rivers of the United States it is also important, though the shad has been driven from some, and is greatly diminished in most others by injudicious damming and overfishing. Thus, from being a food-staple, it has become to some degree a luxury, and alarm is entertained lest this important fish may suffer the fate of the Atlantic salmon. Its spawning habits, the vigor of the young, and their quick descent to the sea have enabled the shad to outlive the conditions which have deprived us of the salmon. Efforts were made, therefore, to assist nature in the preservation of this valuable food-supply: First, by the construction of fish-ways over dams, by the aid of which the shad might ascend to their native spawning

grounds, and the removal of the fish-wears, which destroy the young shad by the thousands. Secondly, efforts were made to restrict fishing by regulations, in which the size of the net meshes is prescribed, so that young fishes may escape; Sunday fishing is prohibited, leaving the fish free to make their run on that day; and a day is fixed on which the fishing season must end—this being June 10 on the Delaware.

But both the natural preservatives and these attempts to assist nature have proved of little avail against persistent overfishing, stimulated by commercial greed.

In the lower reaches of our rivers, which are still accessible to the shad, the restricted spawning grounds are industriously and assiduously swept with drift net and seine, and innumerable tyke nets and pounds effectually bar all approaches, so that natural reproduction is in a great measure impracticable even for the shad that find their way into the rivers and to the vicinity of their spawning grounds. More serious than all, however, has been the transfer of the shad fisheries to the estuaries of the rivers, and the substitution of the pound net for gill net and seine. In consequence of this change in the location of the fishing grounds the larger proportion of the shad captured are now taken in salt or brackish water, in which natural reproduction cannot be accomplished. Indeed, so small is the proportion of the seasonable run of shad which succeed in making their way into and up our rivers and reaching their spawning grounds, that natural reproduction has ceased to be a material factor in influencing the conditions affecting our shad fisheries.

Resort has therefore been had, finally, to artificial shad-culture, planting the streams with multitudes of fry and young shad. This has been the work chiefly of the U. S. Fish Commission. In 1875 it began operations with a view to introducing shad in those river basins in which that species was not indigenous. But the census of 1880 and other investigations having proved that the shad fisheries of the Atlantic coast rivers were rapidly declining, the commissioners advanced to the further work of artificial propagation and distribution of young shad in those very rivers. They undertook to rescue from waste the eggs taken from the shad captured by the fishermen, to impregnate, hatch, and return these to their native waters. The conditions were shown to be highly unfavorable, but the commission attacked the problem resolutely, and the remarkable results in 1885 and succeeding years are shown in the following table:

Year.	Catch in salt and brackish waters.	Catch in the rivers.	Total catch.
1880.....	2,549,544	1,591,424	4,140,968
1885.....	3,267,497	1,906,434	5,172,931
1886.....	3,008,768	2,485,000	5,584,968
1887.....	3,813,744	2,401,661	6,215,405
1888.....	5,010,101	2,650,373	7,660,474

As the average weight of shad is four pounds, this table shows an addition to the food-supply, in 1888, of 3,519,506 pounds over that of 1880, and the money value of the increase is estimated at \$704,101. The increased production of this fishery is to be attributed to the piscicultural work of the United States Fish Commission. The increased value of this fishery is a measure of the economic value of this work to the people of the country.

In addition to the white shad there is a second species on our coast, known as the Hickory shad (*C. mediocris*). This has been given several local names, and is distinguished from the former by having a row of spots on its side. It does not oc-

cur in any considerable numbers in the rivers north of New York, but is rather abundant in some of the southern streams. It is lean, and of little value as a food-fish, being ordinarily sold at about half the price of the white shad. (C. M.)

SHAMOKIN, a borough of Pennsylvania, in Northumberland Co., is on a branch of the Philadelphia and Reading Railroad, W. of Ashland, and on a branch of the Northern Central Railroad, 19 miles S. E. of Sunbury. It has a national bank, 2 other banks, 12 churches, a high school, and other schools. It is a mining town, being in the anthracite coal region. It had in 1880 a population of 8184.

SHARON, a borough of Mercer Co., Pa., is on the Shenango river, near the Ohio boundary, 21 miles N. W. of Newcastle and 70 miles N. N. W. of Pittsburg. It is on the New York, Pennsylvania and Ohio, the Erie and Pittsburg, and the Shenango Valley Railroads. It has 2 national banks, 1 other bank, 14 churches, 5 schools, 1 daily and 2 weekly newspapers. It is largely engaged in coal and iron working, and has 3 rolling mills, steel works, chain factory, boiler works, machine shops. There are also planing mills, flouring mills, and soap works. It has water-works and gas-works. Natural gas is largely used. Sharon was settled in 1815, and incorporated as a borough in 1843. Its property is valued at \$3,500,000; its public debt is \$41,500, and its yearly expenses are \$37,000. Its population in 1880 was 5684.

SHARSWOOD, GEORGE (1810-1883), jurist, was born in Philadelphia, July 7, 1810. His grandfather, by whom he was brought up, owing to the early death of his father, had been a captain in the Revolutionary army, and was active in local politics. The grandson, after graduating at the University of Pennsylvania in 1828, studied law with Joseph R. Ingersoll, to whom he dedicated his treatise on *Professional Ethics* (1854). In 1837 he served in the State legislature and again in 1841-42. The report made by him at this time as secretary of a committee of stockholders to examine the affairs of the U. S. Bank may be found in Benton's *Thirty Years' View* (II, 370). His mastery of numerous branches of law was well displayed in his editions of various English text-books, including *Blackstone's Commentaries*, and in the *American Law Magazine*, which he conducted for three years. In 1845 he was nominated by Gov. Shunk associate judge of the district court of Philadelphia, and soon became president of the court. When the judiciary was made elective, in 1850, Judge Sharswood was nominated unanimously in the conventions of five political parties. After serving in the district court for twenty-two years, he was in 1868 elected to the State supreme court. He then resigned the professorship of law in the University of Pennsylvania, which he had held for eighteen years. When he retired from the Supreme bench, at the close of his term in 1883, he was honored with a public testimonial in which the highest tribute was paid to his judicial ability. Throughout his career he had maintained the Democratic view of strict construction of the Federal Constitution; in particular, he had denied the constitutionality of making greenbacks a legal tender. Besides his works already mentioned, he published *Lectures on Commercial Law* (1856) and *Law Lectures* (1869). His edition of *Blackstone's Commentaries* is accepted as the standard in America, and his annotations on other works were republished in England. He died at Philadelphia, May 28, 1883.

SHAW, LEMUEL (1781-1861), jurist, was born, Jan. 9, 1781, at Barnstable, Mass.; graduated at Harvard, 1800; served for a year as usher in the Franklin (now Brimmer) school, Boston; was assistant editor on the *Boston Gazette*, and studied law under

David Everett. In 1804 he was admitted to the bar, and began practice in Boston, gradually rising to eminence. He was a member of the State legislature from 1811 to 1815, and again in 1819, and of the convention for revising the laws of the State in 1820. In 1821-22 he was State senator, and also in 1828-30. In 1830, though never holding any previous judicial position, he was made chief-justice of the supreme court of Massachusetts, holding the office till his resignation in 1860. Here he acquired a reputation as a jurist second only to that of Theophilus Parsons. His reported decisions are to be found in the reports of Pickering, Metcalf, Cushing, and Gray, constituting in all 50 volumes. He was an overseer of Harvard College for 22 years, and received the honorary degree of LL. D. from it in 1831, and from Brown University in 1850. Probably his most important writing, apart from his decisions, is the charter of the city of Boston, draughted by him in 1822. He died in Boston, March 30, 1861.

SHAYS, DANIEL (1747-1825), from whom the rebellion in Massachusetts in 1786 takes its name, was born at Hopkinton in 1747. He was an ensign at the battle of Bunker Hill, and afterward a captain. At the close of the Revolutionary war the people of western Massachusetts found themselves burdened with debt and taxes, and laid the blame on the legislature. They demanded the removal of the General Court from Boston, the reduction of salaries of officials, the relief of debtors, and the issue of paper money. Parties of armed men interrupted the sessions of several county courts. Capt. Shays was chosen as a leader, and in December, 1786, prevented the courts from meeting at Worcester and Springfield, and then made an unsuccessful attempt to capture the arsenal, Jan. 25, 1787. His men, poorly clad, had already suffered severely from the intense cold, and were thoroughly alarmed at the vigorous measures taken against them by the State government. Gen. Benjamin Lincoln surprised and dispersed them at Petersham, and Shays fled to Vermont. He was afterward pardoned, and finally even pensioned for his services in the Revolution. He died at Sparta, N. Y., Sept. 29, 1825.

SHEA, JOHN GILMARY, historian, was born in New York City, July 22, 1824. Educated at the grammar school of Columbia College, he was admitted to the bar, but has been chiefly engaged in literature. He spent six years in the Society of Jesus, and devoted much attention to the history of Jesuit missions in America. His publications include *Discovery and Exploration of the Mississippi Valley* (1853); *Catholic Missions among the Indian Tribes* (1854); *Bibliography of American Catholic Bibles* (1859); *Early Voyages up and down the Mississippi* (1862). He edited several works relating to colonial New York and to the American Indians. From 1859 to 1865 he was editor of the *Historical Magazine*, and he has since been connected with various journals and monthlies. To American Catholic literature he has been a liberal contributor of translations and editions of foreign works, as well as original publications. Besides correcting and editing English Catholic Bibles, he issued a *Bible Dictionary* (1873); *Child's History of the United States* (3 vols., 1872-73); and various school text-books. He contributed to this work the article on ROMAN CATHOLIC CHURCH.

SHEBOYGAN, a city of Wisconsin, seat of Sheboygan county, is on Lake Michigan at the mouth of the Sheboygan river, 52 miles north of Milwaukee. It is on the Milwaukee, Lake Shore and Western, and the Chicago and Northwestern Railroads. It has a court-house, 2 hotels, German bank, 5 churches, 2 daily and 4 weekly newspapers, two of which are German. There are 3 foundries, 3 planing mills, and factories manufacturing chairs, toys, furniture,

and shoes. There are also tanneries and breweries. Sheboygan has a good harbor, is lighted with gas, and has street cars, parks, and water-works. There is an artesian well 1700 feet deep, whose waters are medicinal. The population is chiefly of German origin, and in 1880 was 7314, but is now estimated to be twice as great.

SHEDD, WILLIAM GREENOUGH THAYER, theologian, was born at Acton, Mass., June 21, 1820. He graduated at the University of Vermont in 1839, and at Andover Theological Seminary in 1843. After a brief pastorate in the Congregational church at Brandon, Vt., he was made professor of English literature in the University of Vermont in 1845. Thence he passed in 1852 to Auburn Theological Seminary as professor of sacred rhetoric, and in 1854 became professor of ecclesiastical history in Andover Seminary. In 1862 he was called to be associate pastor with Rev. Dr. Gardiner Spring in the Brick Presbyterian Church, New York City. In 1864 he was made professor of Biblical literature in Union Theological Seminary, and in 1874 became professor of systematic theology there. He edited Coleridge's *Works* (1853) and *Augustine's Confessions* (1860); translated some works from the German, published *Discourses and Essays* (1862), *Lectures on the Philosophy of History* (1862), and a valuable *History of Christian Doctrine* (2 vols., 1864). Dr. Shedd edited the *Gospel of Mark*, in Dr. Schaff's edition of Lange's *Commentary*, and has since published *Homiletics and Pastoral Theology* (1867) and *Sermons to the Natural Man* (1871); *Commentary on the Epistle to the Romans* (1879); *Sermons to the Spiritual Man* (1884); *Doctrine of Endless Punishment* (1885); *Dogmatic Theology* (2 vols., 1888).

SHEEP. *Ovis*, the genus of the sheep, is by some authors considered to represent a group of three or four genera, embracing in all, according to a recent systematist, about 21 species. The more general opinion, however, makes but one genus and a much smaller number of species. In the wild state both sexes of the sheep are horned. The horn is large, angular in form, and spirally twisted, curving in such a manner that the tips point forward. It is transversely striated or ridged, and in some species is very large. The hair is of two kinds, a woolly internal coat, and an exterior covering of closer and harsher hair.

In its native state the sheep closely approaches the goat in energy and activity. It is of larger size and equal muscular power, and is, like it, a mountain dweller, leaping from rock to rock with the greatest swiftness and agility. Of the wild species the most important are the Musmon (*O. musmon*) of European Turkey and the mountainous islands of the Mediterranean; the Argali (*O. ammon*) of the mountains of Central Asia; the African bearded sheep (*O. tragelaphus*) of Egypt and Barbary; and the Rocky Mountain sheep of America (*O. montana*). The latter species, called Big Horn, is found from the hills of western Nebraska to the coast ranges of the Pacific, and from the Rio Grande far to the north. It is said to range to 68° north latitude, but is not found in the hills of the Hudson Bay region. In the mountains of its range it occurs in flocks of from three to thirty, and is remarkably agile and daring. From which of these species the domestic sheep (*O. aries*) originated is not known. It has been so long domesticated that no close resemblance to any wild species remains. It differs from the wild sheep in its more massive trunk, slender legs, and less graceful aspect of body, and in the great predominance of its woolly over its hairy covering. The horns have varied or disappeared, the ears and tail lengthened, and other modifications taken place. In a state of captivity the sheep is markedly grega-

rious, timid, and defenceless, and has become thoroughly adapted to life on level plains. In these respects it has changed much more than the goat.

The domestic sheep has deviated into a great variety of breeds, several of them with extraordinary peculiarities. One of these is the fat-tailed sheep of southwestern Asia, in which the tail is so loaded with fat as to sometimes weigh twenty pounds; another, the tailless fat-rumped sheep of the deserts of Tartary; and a third, the Fezzan sheep of Africa, distinguished by its arched forehead, long ears, and mane on neck and shoulders. In the modern breeding of the sheep two distinct purposes have been kept in view, the production of wool of superior quality and quantity and that of choice and fine-flavored meat. No breeder has yet succeeded in uniting these qualities perfectly in a single breed, and wool and mutton producers are obliged to pursue opposite courses. The growth of fine mutton has long been closely attended to in England, and several of the breeds of that island, notably the Southdown, are celebrated throughout the world for their excellence in this particular. Of wool-producing sheep the best of all known breeds is the Merino, which in recent times has been brought to great perfection in Spain. It is probably the descendant of an ancient breed of western Asia, from which all the fine-wooled sheep have been derived. From Spain the Merino has been introduced into France, Saxony, and other countries of northern Europe, where it has been crossed with the native sheep. It has also been largely imported into the United States, and forms the basis of much the greater percentage of our sheep. The Merino differs from the English sheep in having wool on the forehead and cheeks. It is a large breed, with heavy horns, and fine, long, soft wool, curling in close tendrils, and so oily naturally that the dust adheres to it and gives it a dingy appearance, though it is perfectly white when washed. The average weight of the fleece is four to five pounds. Recent breeding, however, has much improved the qualities of the Merino, and the wool clip of American sheep sometimes reaches a much greater average than this.

The first sheep brought into the present limits of the United States were landed at Jamestown in 1609. Sheep were introduced into New York and Massachusetts about 1625. These increased into considerable flocks, and America was well provided with sheep in 1801, the year in which the first Merinos were brought to this country. These were imported by Mr. Seth Adams to Dorchester, Mass. He afterward took his flock to Ohio, where its descendants were lost in cross breeding. In 1802 Col. David Humphreys brought from Spain to Derby, Conn., 90 choice Merinos. Of this flock one ewe was bought by David Atwood, of Vermont, and became the basis of the famous Atwood flock, the finest flock of pure-blooded Merinos in this country. Merino sheep were for a time highly popular, and were imported in large numbers, more than 15,000 being brought over in 1810 and 1811. After the war they fell greatly in price and most of the flocks were dispersed and lost, though they have undoubtedly greatly benefited the sheep of the United States by crossing with the older breeds. The careful breeding of Merinos has mainly been prosecuted in Vermont, where there are several celebrated flocks, while the yield of wool has greatly increased. In Spain the best rams yield only from 6 to 8 lbs. In America the yield has increased until 20 lbs. and, in extreme cases, much beyond this is obtained. The heaviest fleece yet cut from an American Merino was 44 lbs. 4 oz. Such sheep, however, generally lack vigor, and the forcing process by which such yields are produced is not profitable. One unfavorable result of very high breeding

is to augment the constitutional lack of fertility of the Merinos.

We have spoken particularly of the introduction of the Merino to America, from the fact that

its stock from the prairie region. Throughout this whole western country, which has abundant pasturage admirably adapted for sheep culture, the increase of sheep flocks within recent years has been very great. In Texas the wool clip increased from 7,000,000 lbs. in 1870 to 22,000,000 lbs. in 1880, and the increase elsewhere has been equally promising.

Of the English breeds introduced into this country the principal are the Southdown, Leicester, and Cotswold. Of these the Southdown is preferred by many to the Merino, being one-third larger, harder, much more prolific, and yielding better mutton. Its wool is large in quantity and fair in quality. The Leicester breed has a heavier fleece and carcass than the Merino, but needs more food.

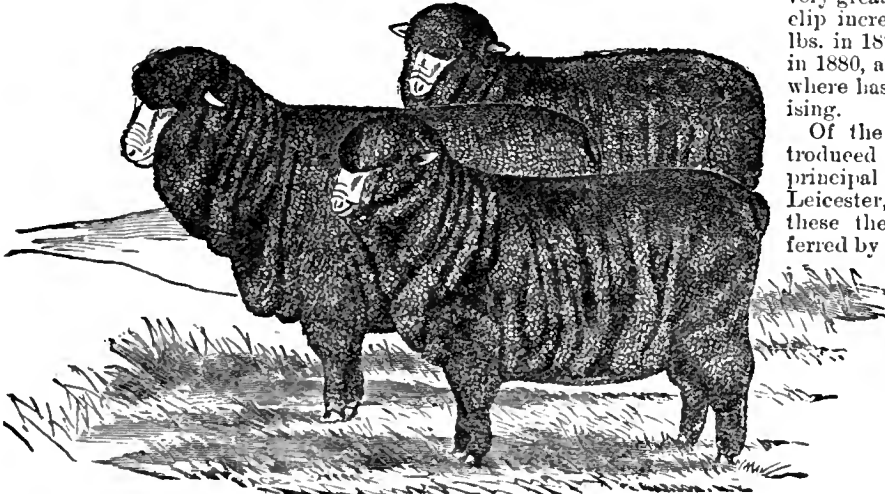

American Merino Sheep.

this breed now forms the basis of the American sheep industry. In the words of a recent authority: "England is a mutton, America a wool country; the sheep of the United States are 95 per cent. Merino." Of English sheep there is only one breed, the Southdown, whose wool is comparatively fine. On the other hand, the mutton of the mature American Merino is often excellent, and occasionally approaches the Southdown in quality. On the Atlantic slope of the United States the Merino sheep has no pre-eminence, except in limited localities, as in Vermont. There is a greater proportion of the old American stock, described by Youatt as a mongrel Southdown with Leicester and Cotswold. In most of the southern States there has been little careful breeding, the sheep being left to care for themselves. In the West the breeds are better defined and more improved. Much attention has been given to the breeding of the Merino in western Pennsylvania, West Virginia, and Ohio, and more recently in Michigan and Wisconsin, in which States wool predominates over mutton production. Less care has been given to the Merino in the prairie region, and there has been much cross breeding. The English long-wooled sheep appear to do better in this region, they being less affected by its characteristic disease of foot rot. In Texas and New Mexico, among the most important of our sheep-raising districts, the original sheep was the Mexican, a descendant from the *Chourro* of the Basque provinces of Spain. This is a long, lank, light sheep, with little and poor wool, but with the advantage of being very hardy and prolific. The Merino was introduced into Texas in 1852, and has greatly increased in that State, its constitutional defects being overcome by crossing with the Mexican stock. The sheep stock of Texas is now said to be $\frac{1}{2}$ Mexican, $\frac{1}{4}$ half-Mexican, and the remainder half to pure Merino. In New Mexico the great bulk of the sheep are Mexican. California, which is now one of the most important of our sheep-raising States, began this industry in 1852. The sheep there are said to be 75 per cent. pure Merino, but, having been grafted on the old Mexican or Mission stock, are very hardy and prolific, while excellent wool-bearers. The remainder of the Pacific States and Territories have derived their sheep from California, their stock being mostly Merinos. Colorado, an important sheep-raising State, has obtained

Its wool is long staple, but, like English wools generally, is deficient in felting properties and therefore unsuitable for cloths. As a combing wool it stands first, and is used to manufacture the finest worsteds. The Cotswold is also much esteemed, yielding excellent mutton and fair wool. As a rule the fine-wooled sheep, like the Merino, are less profitable as mutton producers than the coarse-wooled, no satisfactory combination of excellence in mutton and fineness in wool having yet been produced. Sheep generally produce finer wool in cold than in warm countries, though in the latter the yield is greater, probably from the greater abundance of nutritious food.

The principal breeds of sheep now raised in the United States are the (so-called) Natives, the Spanish and the Saxon Merinos, the New Leicester or Bakewell, the Southdown, the Cotswold, the Cheviot, and the Lincoln. The common sheep of Holland were early imported by the Dutch settlers of New York, but do not now exist as a distinct variety. The broad-tailed sheep of Asia and Africa has been several times imported from Persia, Tunis, Asia Minor, etc. The United States, on the other hand, has done little in the way of producing distinctive breeds, perhaps from lack of efforts at selection. The mis-called Native is in no sense indigenous, but is the outcome of indiscriminate crossing of the earlier importations, mostly of English varieties. Two races of distinctive character have arisen, the Otter and the Smith's Island breeds, but no trace of them is now known to exist. The Otter made its appearance in Massachusetts in 1791. A lamb was born with longer body and shorter legs than usual, and as this promised to check the tendency to leap over fences, it was carefully bred from; but the breed has been allowed to die out.

A very great variety of crosses have been made between the Spanish, English, and Natives, this having been practised to such an extent that few United States flocks are now of pure blood. This has not been wholly the result of carelessness, but was done in many cases advisedly for the purpose of combining the advantages of separate breeds. And even where efforts to preserve purity of blood have been made, certain variations have arisen incident to a new country and new management. Thus the American Merinos have diverged into varieties presenting marked differences from each other and from

the original Spanish. These may be classed under three heads. The first is a large, short-legged, strong, and exceedingly hardy sheep, with heavy fleece, ranging in quality from medium to fine, free from hair in well-bred flocks, the wool being longish on both back and belly, and exceedingly dense. The yield of fleece is heavy, averaging from 8 to 12 lbs. The second is a smaller and less hardy variety, the wool usually finer, and covered on its extremities with a black, pitchy gum. The fleece is about one-fourth lighter than that of the above. The third variety is still smaller and less hardy, with lighter but finer fleeces, which are free from gum. It closely resembles in form and wool the Saxon Merino, and may have some Saxon blood. The first variety is a larger and stronger sheep than the original importation from Spain, and in well-selected flocks yields much heavier fleeces and of much better quality than those obtained in Spain. The Merino, though native to a warm climate, becomes readily acclimated to cold regions, and flourishes as far north as Sweden without degeneration. It is patient and docile, and of great longevity, retaining its teeth and breeding 2 or 3 years longer than the common sheep, and at least 6 years longer than the improved English breeds.

What are known as the Saxon Merinos originated from a flock of 200 Spanish sheep imported to Saxony in 1765. They were bred with great care, and improved over the original in quality of wool, though hardiness and other important qualities have been sacrificed by the German shepherds in their too exclusive attention to wool product. There are two distinct breeds of the Saxon, one with shorter legs and stouter body than the other. The first Saxons were imported to America in 1824, with the exception of a small flock of 6 or 7 brought earlier. Many were brought later. These have been mixed with natives and Spanish Merinos, to the advantage of their hardiness. The American Saxons yield a fleece of 2 to 3 lbs. They are comparatively tender, need regular and good food, and good shelter. They resemble the Merinos in docility, longevity, and lateness of maturity, and yield a fleece not so fine as that of Saxony, but usually much finer than that of the American Merino.

Of the English breeds the Leicester was introduced into the United States about 1825. Its mutton has deteriorated in quality from that of England, being too fat, and the fat and lean too little mingled, for the American taste. Its wool is not in much demand here, from the dearth of worsted manufacturers in America. It is comparatively short-lived and, being a lowland sheep, does not stand our winters so well as the Southdown, which is of upland origin, and is quite hardy and healthy. Like the Leicester, it is short-lived. Of the broad-tailed sheep there are some of pure blood within the United States, but they are as yet of no industrial importance.

The celebrated Improved Kentucky breed was formed by a general crossing of the Native, Merino, and the English breeds, but is considered one of the most permanent of American breeds, propagating with the certainty of the average thoroughbred. Crosses between the distinct varieties of Merinos have been highly successful, and the American Merino of to-day is the result of a fusion of several Spanish flocks. The "Victor-Beall Delaine," the "Blacktop," and the "Improved Saxony," all excellent American breeds, are the result of crosses between Spanish and Saxon Merinos. Similar crosses of American with French Merinos have not resulted advantageously in the eastern States, but have proved successful in California. In Oregon and California the American and Australian sheep have been bred together, with very satisfactory results. It is said that the cross between a Merino

ram and a Southdown ewe, and *vice versa*, yields the best mutton known, with the exception of the little Welsh mountain sheep. It is claimed to be superior to pure Southdown mutton.

In the far West the question of food-supply for sheep is a very important one. Those vast regions are widely adapted to pastoral pursuits, and seem destined to become the future home of the American Merino, but some system of shelter and artificial provision of food is necessary to guard the flock against the occasional heavy snows. The prairie hay is generally excellent, and the grass known as alfalfa has proved well suited to sheep pasture in California. The Bermuda grass, so common and dreaded by the cotton planters of the South, has been found to succeed well in the alkaline soil of the West, and is admirable for sheep. *Festuca*, a large genus of grasses, follows sheep and cattle everywhere; *F. ovina*, one of the best of sheep grasses, having followed the sheep around the world. There are several species of the bunch grass of the western plains which are also excellent, and by a system of gathering sufficient of these grasses to carry the flocks over the dangerous periods of the winter the sheep industry may be almost indefinitely extended in the West. Sheep are excellent scavengers, and thrive where most other animals would starve. They bite the grass much closer than the other domestic animals, and are fond of plants which the latter will not eat. They soon clear fields of weeds, briars, and bushes, and by their droppings, which have excellent fertilizing properties, they aid greatly in preparing the land for the plough. Where briars are too thick and high they need to be burned; yet this does not deter the sheep, which crop down all the young shoots which appear on such burned-over ground, with an apparent preference, as if the ashes gave a relish to their food. Their close cropping, indeed, is fatal to certain species of grass, and in sheep pastures it is necessary to select grasses which will bear this. (See FORAGE CROPS.)

Sheep are subject to many diseases which interfere seriously with their profitable raising. The most troublesome of these is the foot rot. This arises from the suppression of the peculiar glandular secretion which exudes between the toes of the sheep. Moist ground promotes this suppression, which is followed by dangerous inflammation. They suffer also from insects, and particularly from a botfly, whose larva is introduced into their lips and nostrils, and makes its way inward to vital regions. There are other parasites and diseases which add greatly to the cares and risks of the shepherd.

The number of sheep in the United States in 1880 was 42,192,074, of which 35,192,074 were on farms, and 7,000,000 estimated on ranches and ranges. In 1888 the number was 43,544,755. The wool clip of the former-named year was 240,681,751 lbs., of which the principal quantity came from Ohio, California, and Michigan. The price of sheep advanced steadily from 1879 to 1883, after which a decline set in, the price in 1888 being \$2.05, and the total value of sheep, \$89,276,026. Of this value Ohio and California return over \$10,000,000 each; Texas, nearly \$7,000,000; New York and Michigan, over \$5,000,000; Oregon, nearly \$5,000,000; and the other States in rapidly diminishing proportions.

(C. M.)

SHELBY, ISAAC (1750-1826), soldier, and governor of Kentucky, was born near Hagerstown, Md., Dec. 11, 1750. His father, Evan Shelby, was of Welsh descent and local prominence. In 1774 Isaac fought in his father's command against the Indians at Point Pleasant, Va. In the Revolutionary war he served as captain, commissary, major, and finally colonel, in Virginia and the Carolinas. His most noted exploit was his gathering a force of hardy

rifemen from the Wauanga settlements, and leading them across the mountains against the disciplined Tories under Major Patrick Ferguson, whom he completely defeated at King's Mountain, Oct. 7, 1780. This unexpected blow greatly revived the patriot cause in the Southern States. In the next year Shelly assisted Marion, and led 500 men to the aid of Gen. Greene. He was then elected to the North Carolina legislature, and received from that body a vote of thanks and a sword. In 1783 he removed to Kentucky, and took part in framing a constitution for that State, on its separation from Virginia. He was chosen its first governor, 1792-96, and was again called to this post in 1812, when the second war with Great Britain was declared. He led a force of 4000 to Gen. Harrison's army, and fought at the battle of the Thames. His term as governor expired in 1816, and he was invited by Pres. Monroe to become secretary of war, but declined on account of his age. Yet in 1818 he was joined with Gen. Jackson in making a treaty with the Chickasaw Indians. He died at Traveller's Rest, Lincoln Co., Ky., July 18, 1823.

SHELTON, FREDERICK WILLIAM, clergyman and author, was born at Jamaica, L. I., in 1814. The son of a physician, he graduated at Princeton in 1834, and employed his pen in writing for the *Knickerbocker Magazine*. His rhymed satire, *The Trollpiad; or, Travelling Gentlemen in America*, was published anonymously in 1837. After being ordained in the Episcopal Church, in 1847, Shelton ministered to parishes at Huntington, L. I., Fishkill, N. Y., and Montpelier, Vt. He died at Carthage Landing, N. Y., June 20, 1881. His books, *The Rector of St. Bardolph's* (1852), *Up the River* (1853), and *Peeps from a Belfry* (1855), exhibit his experiences and reflections as a rural clergyman. His *Subtler and the Dragon* (1850) and *Crystalline* (1854) are fairy tales with a moral.

SHENANDOAH, a borough of Schuylkill Co., Pa., is on the Lehigh Valley, and the Philadelphia and Reading Railroads, 13 miles N. of Pottsville. It has a national bank, 12 churches, several schools, 2 daily and 3 weekly newspapers, and a foundry. The business is almost exclusively mining and shipping anthracite coal. (See ANTHRACITE under COAL.) The collieries in the vicinity produce to the value of \$2,500,000 yearly. Shenandoah was settled in 1852, and incorporated in 1863. The inhabitants are chiefly of foreign birth. The borough has gas and water-works. Its property is assessed at \$1,600,000; its public debt is \$75,000, and its yearly expenses are \$40,000.

SHENANDOAH VALLEY owes its historic interest to the American civil war, and is here described with reference to the campaigns which have rendered it memorable. It takes its name from the Shenandoah river, which is formed by the junction of two forks—the North and South—at Front Royal. These forks are separated for 40 miles by the isolated range of the Massanutten. The South Fork, or the Shenandoah proper, rises by three branches a little south of the parallel of 33° N. lat. From Front Royal the river skirts the western base of the Blue Ridge, till it falls into the Potomac at Harper's Ferry, after a total course of 170 miles. The valley between the Blue Ridge, on the east, and the North mountain, on the west, has an average breadth of 20 miles, and stretches from the Potomac beyond the sources of the Shenandoah, and into North Carolina. Its direction is from N. E. to S. W. The valley divides itself, by a line drawn through Lexington, into two parts—the southern, mountainous, rugged, and unfit for military movements; and the northern, rich and fertile, affording an army a natural avenue of communication, while furnishing an inexhaustible granary for its commissariat. Besides the Shenandoah,

the other streams of the region are the North river, an affluent of the James, on which Lexington stands; the Kanawha, whose main branch, New river, flows N. W. across the valley from its S. E. angle, until it enters West Virginia; Cedar creek, falling into the South Fork at Strasburg; and the Opequan, a small stream, rising in Frederick Co. and flowing N. into the Potomac near Williamsport.

When Virginia seceded, in May, 1861, the civil war had already begun. From its proximity to the national capital, this State was plainly indicated as the field of the struggle for the nation's life. The capital of the Southern Confederacy was promptly transferred to Richmond, and the ground between the two capitals became, for four years, the scene of the most momentous American conflicts. The valleys of Virginia, as grand military avenues, were the favorite field of strategy for both parties, and their railroads were a main object of attack and defence. The main Union line was the Baltimore and Ohio, traversing the north of the valley. The Confederate lines were the Virginia Central, whose chief valley station was Staunton, and the East Tennessee, which connected Lynchburg and Knoxville. Military operations were facilitated by the fine roads connecting the towns, while the gaps of the Blue Ridge gave access to East Virginia. Through one of these gaps—Manassas—there was a railroad, but it was broken up early in the war. The valley was the scene of the operations of the Confederate generals, Jackson, Ewell, Stuart, and Early, on a large scale; and of the romantic enterprises of Ashby, Mosby, Imboden, and Gilmor.

The initial campaign of the war in 1861 turned on the effective use made of the military advantages of the valley by the Confederate general, J. E. Johnston. Gen. Robert Patterson had crossed the Potomac to watch his movements and prevent his joining Beauregard, whose army was threatened by McDowell's advance from Washington. But Johnston, with the main body of his "Army of the Shenandoah," slipped through Ashby's Gap and took the railroad to Manassas. This re-enforcement caused the defeat of the Union army on July 21. (See BULL RUN.)

At the beginning of the campaign of 1862 Gen. Johnston, still in command, sustained a check from Gen. James Shields; but for this he indemnified himself a few months later when he fell on Shields at Port Republic, defeated Fremont at Cross Keys, captured the garrison of Front Royal, drove Gen. N. P. Banks across the Potomac, and, by alarming Washington, prevented the intended junction of McDowell's army with McClellan's, and thus, in the judgment of some military critics, averted the capture of Richmond at that time. It was there in the Shenandoah Valley that Gen. "Stonewall" Jackson began to practise in his unique and masterly way the game of war. From it he hastened to turn McClellan's right in his Peninsular campaign. At the close of that campaign the command of the Confederate army had devolved on Gen. Robert E. Lee.

When the safety of Richmond was assured by the withdrawal of the Union army from its vicinity and the defeat of Gen. Pope at the second battle of Bull Run (*q. v.*), Gen. Lee determined in the autumn of 1862 on a counter movement—the invasion of the North, and transfer of the conflict to Maryland and Pennsylvania. The Shenandoah Valley was his line of communication, and at Harper's Ferry he captured 11,000 men, 73 guns, and 13,000 stands of arms. He was repulsed, however, at Antietam (see SOUTH MOUNTAIN) and was obliged to seek rest again in the valley.

In the next year, after defeating Hooker at Chancellorsville (*q. v.*), Lee used the valley again as his route for the invasion of Pennsylvania. In it Gen.

Ewell captured several thousand Union troops and over 20 guns from Milroy. After the defeat of his army at Gettysburg Lee fell back again by the way of the valley and posted his forces along the Opequan. The importance of the Shenandoah Valley had now been thoroughly tested and proved. Yet the events of the succeeding campaigns gave it still greater prominence. Not until this granary and highway could be wrested from the Confederate control could the Union designs against Richmond be brought to a successful close.

In March, 1864, Gen. U. S. Grant was promoted to the command of the entire Union army. When he crossed the Rapidan, in the beginning of May, three movements were in progress in the Shenandoah Valley—those of Crook and Averell down the Kanawha from West Virginia, and that of Sigel up the Shenandoah, the common objects being the breaking up of the Virginia Central and Tennessee railroads and the destruction of the works at Wytheville and Saltville, and then marching their united troops under Sigel to Lynchburg in support of Grant. The scheme miscarried in its main object. Sigel, in particular, was defeated by Breckenridge at New Market, and the command of the Department of West Virginia was transferred from him to Gen. Hunter. Crook and Averell returned to West Virginia.

The second attempt to effect these ends was made in the end of May under Gen. David Hunter. Moving up the valley he, on June 5th, encountered the enemy under Jones at Piedmont, and drove it back to Staunton with loss of guns and 1500 prisoners. Jones was killed. On Crook's approach from the west the remainder of Jones' force, abandoning Staunton, fled, pursued by Hunter to Waynesboro'. At Staunton, the factories and stores were destroyed, the railroad broken, and a junction effected with Crook and Averell. On June 10th Hunter's consolidated force, 18,000 strong, set out to follow the enemy farther up the valley. On reaching the New river, opposite Lexington, he found the bluff on the farther bank occupied by the enemy under McCausland. The resistance was easily overcome, and Lexington occupied. Here considerable damage was inflicted, and a statue of Washington carried off.

Hunter now directed his march on Lynchburg, and on the 17th touched the enemy's first line within six miles of the town. Here he encountered Breckenridge, while on the same day Early, whom Sheridan should have detained, arrived at Lynchburg from Charlottesville. Severe fighting occurred on the 18th, but Hunter found the enemy so strong that, 9 p. m., he commenced a retreat which was to continue day after day, with Early in close pursuit, till, on the 27th, his exhausted and half-famished soldiery found supplies and rest, within a day's march of Ganley Bridge, W. Va. Next day Hunter retired to Loup Creek, near Ganley Bridge, and the retreat was at an end.

Hunter's retreat to West Virginia left the valley open to the enemy. Early seized the opportunity to make his famous raid into Maryland and advance on Washington. On July 11th he stood within view of the capital, but, re-enforcements arriving from all quarters, he had no alternative but to withdraw, followed on his retreat by Wright. On the 14th he re-entered the valley through Snicker's and Ashby's Gaps. At Snicker's Ferry he crossed the Shenandoah, and, repulsing Crook in his endeavor to cross in pursuit, he moved leisurely on to Winchester and finally to Strasburg. But in the meantime Hunter's forces from the west were coming on the scene. On the 19th Averell moved from Martinsburg, and on the 20th, encountering Ramsenr three miles north of Winchester, put him to flight with loss of guns and prisoners. At Kernstown, on the 22d, Averell was

joined by Crook, who took the command. Next day they were attacked and defeated by Early, Crook retreating into Maryland.

Early was now again master of the valley, and began afresh to destroy the B. & O. Railroad at Martinsburg. Grant, perceiving that the valley, dominated by Early, would be a permanent menace to the North, determined to accumulate an overwhelming force against him. With this view a "Middle Military Division" was created, and Gen. Phil. H. Sheridan, on August 7th, named to the command of it. His army—afterward to be known as "The Army of the Shenandoah"—consisted of the 6th and 19th Army Corps, Crook's infantry, Torbert's division of cavalry, and four brigades of Hunter's cavalry—amounting in all to 45,000 men, with 22 batteries of 6 guns each. Some of these, however, had yet to report.

Sheridan at once selected a strong position (to which he repeatedly returned) stretching from Clifton to Berryville, near the line of the Harper's Ferry and Winchester Railroad. Opequan Creek ran along its front on the east. Early stood in the vicinity of Bunker Hill, to the northwest of the Union lines. Observing, on the 10th, that Sheridan was in movement to interpose between him and Winchester, he moved rapidly southward, and covered that town. Next day, in order to be nearer the re-enforcements that he knew to be approaching him from Lee, he moved farther south, through Strasburg, and on the 12th took up a strong position on Fisher's Hill, two miles to the south of Strasburg. Sheridan followed him as far as Cedar Creek, and considerable fighting took place. At Fisher's Hill Early was joined by Gen. Anderson, bringing with him Kershaw's infantry, Fitz Lee's cavalry, and Cutshaw's artillery, and also by McCausland's infantry, whereby his force was brought close up to 40,000 men, with 14 batteries of 6 guns each. Sheridan, now considering the enemy too strong to be assaulted in such a position, retired on the 17th by way of Winchester to the position whence he had moved a week previously. Here he was re-enforced through Snicker's Gap, and Averell had reported at Martinsburg and Duffie at Charlestown. To impede pursuit Sheridan destroyed all the crops and provisions south of Winchester, and drove off all the cattle. On the 19th Early moved his forces to Bunker Hill, and on the 21st he and Anderson determined to assault Sheridan, whose main force now lay near Charlestown. The Opequan was easily crossed, and a sharp conflict ensued, which resulted in Sheridan moving back to a position before Halltown, the strongest in the valley. After delaying three days before the Halltown lines, Early, leaving Anderson and Cutshaw to watch these in front, moved north to Shepherdstown, repeated conflicts with Torbert's cavalry taking place on the way. Discovering here that it was as impossible to effect anything against Sheridan on his flank as on his front, he withdrew across the Opequan to his old position at Bunker Hill and Winchester, while, on Sept. 3d, Sheridan returned to his familiar Clifton-Berryville lines. Meanwhile Lee had recalled Anderson to himself, and on the same day that Sheridan made his movement he started for Berryville, to cross the Blue Ridge on his way to Richmond. The consequence was he came into collision with the Eighth Corps, just going into camp. After a stout fight Anderson returned to Winchester, to take, later, a more southerly route. For ten days after this there was constant manoeuvring and skirmishing along the Opequan, Gen. McIntosh on the 13th capturing the Eighth South Carolina Infantry. Nothing decisive, however, was effected, and on the 14th Anderson, with Kershaw and Cutshaw, left to join Lee.

Sheridan saw that the moment he had waited for had come, and proceeded at once to seize it. Early was not only weakened by Anderson's and Kershaw's

withdrawal, but he further depleted his ranks by sending a large section of his army to Martinsburg. Thus on the eve of a day destined to witness a great and decisive battle, the Confederate forces, instead of being concentrated, were strung along the pike. The centre of the position was Bunker Hill, while Winchester was strongly held by Ramseur, and there the fighting was most severe. By a rapid advance along the Winchester pike Sheridan saw that he could gain the rear of the Bunker Hill position. The 6th and 19th Corps began to move at 3 o'clock, morning, followed in three hours by Crook, who joined the main column at the crossing of the Opequan. The enemy resisted the Union advance obstinately, and near mid-day its left was so seriously shaken that the whole attack felt the effect. But by the advance of Russell's division the line was re-established, and the struggle renewed. At length the Confederates began to give way, and as day ended Early's forces broke through Winchester in full retreat. The conflict was a bloody one. The Union loss was from 4900 to 5000; Early's was from 3900 to 4000, and of his casualties 2000 were prisoners. By promptly recognizing his defeat, Early was enabled to save his trains and stores, but he left behind him as trophies five pieces of artillery and nine battle-flags. The fight had been a long and hard one, and there was no attempt at infantry pursuit. The cavalry followed up the pike only to Kernstown, where Ramseur covered the retreat, which, under the shelter of darkness, was continued toward Strasburg. Such was the Battle of Opequan, of which the moral effect in the North was all the greater that, hitherto, it had heard of nothing save discomfiture within the valley, so that it had come to be known as "The Valley of Humiliation."

Next day Early continued his retreat to his old position at Fisher's Hill. Here the valley, through the interposition of the Massanutten, narrows from 20 miles to four, so that the hill offers a strong defensive position—the first that a force advancing from Winchester meets with. At daylight on the 20th Sheridan set forth up the pike in pursuit, and during the afternoon the main body of his army crossed Cedar Creek and went into position on the heights fronting Strasburg. By evening the northern part of that city was occupied by Union pickets, and the southern by Confederate. The 21st was spent by Sheridan in positioning his infantry, his purpose being to repeat the tactics of the Opequan by again turning the enemy's left. On the 22d the assault was delivered just before sunset. Crook, who had been all day moving toward and along Little North Mountain, under cover of the woods, till he had gained the Confederates' flank and rear, rushed across the intervening space, and before they could recover their surprise was over their intrenchments. The other divisions joined in with Crook and took up the charge. Sheridan and his staff were everywhere, shouting: "Go on; don't stop; go on." The whole Confederate line broke from the trenches, and Fisher's Hill was carried, with the additional Confederate loss of 6 guns and 1235 men, of whom 1000 were prisoners. Early fled in disorder, and Sheridan pushed after him the same evening as far as Woodstock. Early made a halt at Port Jackson, but, being attacked by Averell's cavalry on the 23d, he retreated across the North Fork to Reede's Hill near New Market, and thence to Brown's Gap, where he was rejoined by the cavalry of Lomax and Fitz Lee, as well as by Kershaw. Rosser joined a few days later. Here his retreat came to a close.

Sheridan, with his main force, followed as far as Harrisonburg. His cavalry he sent on under Torbert as far as Staunton and Waynesboro', with instructions to burn barns, forage, mills, and whatever might be serviceable to the Confederacy. This in-

struction was thoroughly carried out and the whole region, which, as far up as Staunton, had abounded in food and forage and enabled Early's army to subsist, became desolate.

But this very want of supplies in the upper valley, as well as Early's increased strength, determined Sheridan to retire down the valley, laying waste the region through which he passed so as to make it untenable by, and unprofitable to, the enemy. He writes from Woodstock, on Oct. 7th: "I have destroyed over 2000 barns and 70 mills filled with wheat and flour." He continued his devastating course down the valley, closely followed by the Confederate cavalry under Bosser, with the infantry farther in the rear. Skirmishing between Rosser and Torbert, covering the Union rear, was almost continuous. On Oct. 9th, as the head of the Union column of infantry was entering Strasburg, movements in the rear led Torbert to despatch Custer and Merritt to attack Rosser. The Confederate horsemen yielded to the onset, and a stampede ensued to 7 miles south of Fisher's Hill, their loss amounting to 330 men with eleven pieces of artillery. Torbert characterized this engagement—the battle of Tom's Run, as it was called—as, "among the long list of the cavalry's victories, the most brilliant one of them all." Sheridan then continued to fall back as far as Cedar Creek, fixing his camp on the left bank of the stream just above its junction with the North Fork. While in position here, on Oct. 19th, his force was suddenly attacked before daybreak, the enemy's advance being further concealed by a dense fog. Bewildered by the unexpectedness and vigor of the onset, the left flank of the Eighth Corps was turned and the whole army driven back for miles, with the loss of 24 pieces of artillery and not less than 1300 prisoners. And now occurred the most dramatic incident in the annals of the valley. Sheridan had been absent on business in Washington, and the morning of the 19th found him in Winchester on his return. An officer reported sounds of artillery. Mounting his horse, he rode through Winchester, and then the noise of guns put a battle beyond question, while within a half-mile of the town he met men and trains streaming from the field. Realizing the true condition of affairs, he dashed up the pike with an escort of 20 men, and on reaching the army, 11½ miles from Winchester, he was hailed "with a tempest of joy." "I hastened from Winchester," he writes to Grant at 10 P. M., "and found the armies between Middletown and Newtown, having been driven back four miles. I here took the affair in hand, and quickly united the corps—formed a compact line of battle just in time to repulse an attack of the enemy." At 4 o'clock Sheridan ordered an advance, and the whole Union line responded. His onset was irresistible. Division after division of the Confederates gave way, and the repulse became a rout than which none so complete had been seen since the day of Bull Run. The 24 guns lost in the morning were retaken, and 24 Confederate pieces captured. Ambulances, caissons, and a number of battle-flags were among the spoil, the only trophies retained by Early being 1429 prisoners whom he had despatched toward Richmond. But this victory, plucked, as it were, out of defeat, was purchased at a great price. The Union loss in killed, wounded, and missing summed up to no less than 5764. Early's loss was less—about 3100—of whom over 1000 were prisoners. The pursuit was kept up by the Union cavalry to Mount Jackson, about half-way between Edenburg and New Market.

Cedar Creek constituted the crown of Sheridan's campaign, for, with the exception of a few comparatively unimportant affairs, this closed operations for the year. Gen. Early's force took up a position farther up the valley, while Gen. Sheridan's army

was in detachments widely scattered. Congress a few months after the battle passed a resolution tendering its thanks to Sheridan and his troops for the gallantry, skill, and courage displayed in the brilliant series of victories achieved in the valley. The President also thanked him by letter, in the name of the nation, and a few weeks later appointed him a major-general in the army.

Throughout his campaign Sheridan had been much annoyed by the operations of the guerilla leader Mosby, whose headquarters were to the east of the Blue Ridge in Loudon county. Toward the end of November, by way of retaliation, he sent a division of cavalry into the county to "consume and destroy all forage and subsistence, burn all barns and mills and their contents, and drive off all stock." The commission was executed with ruthless severity.

With the coming of spring, movements in the valley were renewed. On Feb. 27, 1865, Sheridan moved up the river from Winchester at the head of 10,000 sabres, his orders being to destroy the Central Railroad and the James River Canal, capture Lynchburg, and then join Sherman or return to Winchester. Early was found posted on a ridge west of Waynesboro', with two brigades of infantry, a battalion of 6 guns, and Rosser's cavalry. The position was carried in an instant. All Early's wagons, stores, seventeen flags, and eleven guns (including five found in the town), with 1600 prisoners, fell into the victor's hands. Early and the other Confederate generals fled toward Richmond; Sheridan returned to Winchester.

The victory at Waynesboro' left him complete master of the valley. His lieutenants now set about the destruction of the Central Railroad and the canal. This accomplished, the Valley war was at an end. Early was with Lee, and on March 27th Sheridan joined Grant before Petersburg.

SHEPARD, CHARLES UPTAM (1804-1886), physicist, was born at Little Compton, R. I., June 29, 1804; graduated at Amherst College in 1824; studied botany and mineralogy at Harvard under Nuttall, and subsequently taught these branches at Boston. For two years he was Prof. Silliman's assistant in the laboratory of Yale College, and was for one year in charge of the Brewster Institute at New Haven for diffusing a knowledge of science through popular lectures. In the winter of 1832-33 he was employed on a government commission to investigate the culture of the sugar-cane and the manufacture of sugar in the Southern States, the results being embodied in Prof. Silliman's *Report to the Secretary of the Treasury* in 1835. From 1830 to 1847 he was lecturer on natural history at Yale, and was associated with Dr. J. G. Percival, in 1835, in the State geological survey of Connecticut. From 1845 to 1852 he was professor of chemistry and natural history at Amherst, and on the chair being divided in the latter year, was continued as lecturer on natural history till 1877, when he was made professor emeritus. From 1834 till the outbreak of war, in 1861 he filled the chemical chair in the college of Charleston, S. C., and in 1865 resumed its duties for a few years. To him is due the discovery of the rich deposits of phosphate of lime near Charleston, which have proved of great value as fertilizers. Prof. Shepard formed at Amherst the finest collection of meteorites and minerals in the country, which was purchased in 1877 by the college, but partially destroyed by fire in 1880. He was the author of a *Treatise on Mineralogy* (1832; 3d ed., 1855) and a *Report on the Geology of Connecticut* (1855), as well as of numerous papers, appearing chiefly in the "American Journal of Science." The degree of LL. D. was conferred on him by Amherst in 1857, and he was member of many scientific societies, home and foreign. He died at Charleston, S. C., May 1, 1886.

His son, CHARLES UPTAM SHEPARD, Jr., was born at New Haven, Oct. 4, 1842; was prepared for college at Phillips Academy, Andover, Mass.; graduated at Yale, 1863, and at Göttingen, in medicine, 1867. On his return to the United States he was appointed to the chair of chemistry in Charleston, S. C., which he held till 1883, since which time he has been engaged as an analytical chemist, largely in developing the chemical resources of South Carolina as relating to agriculture, first disclosed by his father. In 1887 he presented to Amherst a second cabinet of minerals left by his father, while his own cabinet of meteorites is deposited in the National Museum at Washington.

SHEPLEY, GEORGE FOSTER (1819-1878), judge and general, was born at Saco, Maine, Jan. 1, 1819. His father, ETHER SHEPLEY (1789-1877), had been prominent in the political affairs of Maine from its separation from Massachusetts, serving in the U. S. senate, 1833-36, and afterward in the State supreme court, of which he was chief justice from 1848 to 1855. The son graduated at Dartmouth College in 1837, studied law at Harvard, and began practice at Bangor. He removed to Portland in 1844, and was U. S. district attorney from 1853 to 1861. He had been delegate to the National Democratic Convention in 1860, but on the outbreak of the civil war he was commissioned colonel of the Twelfth Maine Volunteers, and took part in the expedition against New Orleans. In the capture of that city he led a brigade, and was afterward military commandant. His administration was characterized by judicious firmness, which preserved order amid turbulent elements. In June, 1862, his rule was extended over Louisiana; when a loyal civil government was established there, in 1864, and Gen. Butler's army went to Virginia, Gen. Shepley was transferred to the command of the military district of Eastern Virginia. On the capture of Richmond, he was appointed its military governor. He resigned from the army in July, 1865, and in 1869 was appointed U. S. circuit judge for Maine, which office he held till his death at Portland, July 20, 1878.

SHERIDAN, PHILIP HENRY (1831-1888), by military ability eminently deserved the high rank to which he attained—General in the United States Army, a rank previously held only by U. S. Grant and W. T. Sherman. In the last year of Sheridan's life a curious controversy arose as to the place of his birth. His mother settled the matter by stating that "Phil was born, March 6, 1831, in the little frame house still standing in South Street, Somerset, Perry Co., Ohio."

Philip was the second son of John and Mary Sheridan, who emigrated from County Cavan, Ireland, in 1828, and who, after residing a short time in Albany, drifted to the village of Somerset in 1829. Here the father found employment in road-making, bettering himself till he eventually was able to take contracts. Sheridan had two brothers, of whom the younger, Col. Michael V. Sheridan, was, in his later years, on his staff. Philip spent his boyhood working on the homestead and attending the village school, on leaving which he got situations in the village stores successively, each change bringing increased pay. The rollicking Irish boy is yet spoken of in Somerset as ever ready for a frolic or a fight, and yet without an enemy in the place. From his early years he was a lover of soldiers and used to organize the village boys into a company, over whom he was a strict disciplinarian but a good drill-master. He was fond of reading biography and history, especially histories of wars. The victories of Taylor and Scott in 1846-47 probably stimulated his military instincts, and a fortunate application to the congressman of the district gained him in his 17th year a cadetship

in West Point Military Academy, which institution he entered in 1848. Here, for the first six months, he had Henry W. Slocum (afterward major-general) as a room-mate, who helped him materially with his initiatory studies, especially in mathematics. Young Sheridan should have graduated in 1852, but an unfortunate quarrel with a fellow-cadet, who was an officer in the corps, as well as his general propensity for breaking rules, led to his suspension for a year. In 1853 he graduated No. 34 in a class of 52 members. Commissioned as brevet 2d lieutenant, he reported for duty at Newport barracks, Sept. 30, and was next year assigned to the First Infantry in Texas. In November, 1854, he received his commission as 2d lieutenant in the Fourth Infantry. With this regiment he served for six years in Washington Territory and Oregon, at the time when the encroachments of the gold-seekers had provoked the animosity of the Indians. Against these Sheridan was almost constantly engaged, for a time on detached duty in scouting, and this chiefly in command of a detachment of the First Dragoons. In April, 1856, the Indians attacked the blockhouse at the Cascades on the Columbia, W. T., when he at once embarked his dragoons and, after some fighting in conjunction with a few companies of the Ninth Infantry, drove the savages off. For gallantry in this affair he was complimented in orders and promoted to the command of the Indian Reservation. Recalled to the East in September, 1861, by the progress of the civil war, he expressed the modest wish that he "might get a captaincy out of the thing." His aspiration was gratified, June 18, when he received his commission as captain in the Thirteenth Infantry, of which regiment W. T. Sherman was colonel, and the promotion took him to St. Louis. There his first duty was presiding over a court for auditing claims. Next he was appointed quartermaster and commissary on the staff of Gen. S. R. Curtis, in command of the Army of the Southwest, then concentrating in Missouri. In this office he had not the fortune to satisfy his commanding officer and was, in consequence, sent to report to Gen. Halleck, who, after the battle of Shiloh, had taken the command in the advance on Corinth. On May 25, 1862, he was, on the recommendation of Halleck—who had served in California and knew that Sheridan had had command of dragoons—appointed to the colonelcy of the Second Michigan Cavalry, then lying near Corinth.

His active career now began. He led his regiment to Booneville, Miss., where, after taking part in several skirmishes, he was put in command of a brigade composed of his own regiment and the Second Iowa. In command of this he fought the brilliant battle of Booneville, July 1, 1862, for which he was commissioned brigadier-general of volunteers. In the following autumn Sheridan was transferred to the command of the Eleventh Division of the Army of the Ohio (afterward known as the Army of the Cumberland), under Buell, and on Oct. 8 took part in the battle of Perryville against Bragg, where he distinguished himself for resolution, discreet judgment, and ability in handling troops. The army now marched to the relief of Nashville, where its command was transferred to Rosecrans, under whom Sheridan first gave full evidence of his ability as a commander. On Dec. 26 he marched with Rosecrans from before Nashville to the desperate contested two days' fight of Stone River (*q. v.*). Here for three hours his division of McCook's corps held the key of the position, losing all its three brigade commanders killed, and seventy other officers and nearly half its men killed and wounded. His stubborn resistance on this day, coupled with that of Thomas with his gallant corps in the centre, enabled Rosecrans to form his new line of battle for next day. The fighting on the succeeding days

was less vigorous, and on the 3d Bragg withdrew, leaving Murfreesboro' to Rosecrans. For his gallantry here Sheridan was created a major-general of volunteers. Next came the Tullahoma campaign, in which Sheridan's division led the advance, with combats at Fairfield, Cowan Station, and University. This campaign was followed, a few months later, by Rosecrans' advance on Chattanooga and the disastrous battle of Chickamauga, Sept. 19 and 20. Here Sheridan's division suffered from a misunderstanding of orders, and became separated from the rest of the army, and, after desperate fighting, was driven from the field. Sheridan's chagrin at his repulse was brief. Thomas got command of the Army of the Cumberland, whose retreat to Chattanooga he had covered, and when Grant arrived with re-enforcements and undertook to dislodge Bragg, Sheridan's division formed the centre of the column which fought in the conflicts of Lookout Mountain and Missionary Ridge on Nov. 23, 24, and 25, and on the last day carried Missionary Ridge, pierced the Confederate lines, and finally won the fight. His men were the first to cross the crest and press the enemy's rear-guard till long after dark, capturing wagons and artillery. Sheridan continued in West Tennessee through the winter of 1863.

When Grant was called to the command of the Army of the Potomac, in March, 1864, he declared to Pres. Lincoln the urgent need for an energetic leader of cavalry. "I said," Grant reports, "I wanted the very best man in the army for that command. Halleck, who was present, spoke up, saying, 'How would Sheridan do?' I replied, 'The very man I want.'" Accordingly, on April 4, Sheridan took command of the cavalry corps of the Army of the Potomac, and his organizing power quickly brought the corps into the best fighting trim. In the battles of the Wilderness it covered the front and flanks of the infantry, and on May 8 Grant directed its commander to cut himself loose from the army, attack the enemy's cavalry, cut his communications and line of supplies, and sweep round Lee's force to Butler's position on the James at Haxall's Landing. The course he took was directly on Richmond, and involved, on the 10th, the destruction of the Confederate stores at Beaver Dam and recapture of 375 prisoners on their way to Libby prison; on the 11th, the hottest cavalry fight in the war, namely, that with Gen. J. E. B. Stuart at Yellow Tavern, in which the gallant Confederate leader fell; a dash on the defences of Richmond, with the forcing of the Chickahominy, and a fight at Meadow Bridge on the 12th. On the 14th he recrossed the Chickahominy and went into camp on the James, where he rested three days. "Sheridan," says Grant, "in this memorable raid passed entirely around Lee's army, encountered his cavalry in four engagements and defeated them in all, recaptured 400 Union prisoners, and killed and captured many of the enemy, destroyed and used many supplies and munitions of war, destroyed miles of railroad and telegraph, and freed us from annoyances by the cavalry of the enemy for more than two weeks."

Resuming the advance with Grant, Sheridan fought at Hawes' Store, May 28; Matadequin Creek, May 30; and at Cold Harbor, May 31 and June 1. On the 6th of June he was despatched to cut the Virginia Central Railroad near Charlottesville, and to escort the Shenandoah forces of Gen. Hunter to those of Grant. In marching to execute this, his advance was disputed on the 11th at Trevillian Station by Gen. Wade Hampton, whom, after severe conflict, he succeeded in repulsing. The march, however, had not been executed with Sheridan's usual vigor, and on the 12th, though within 30 miles of Charlottesville, he withdrew after breaking the

railroad at Trevillian, leaving the main object of the expedition unaccomplished.

Gen. Sheridan was now transferred to another scene of action, in which he was to win new fame as the leader of an independent command. Early had assumed a threatening attitude in the Shenandoah Valley, and on Aug. 7 Sheridan was put in command of the Middle Military Division, consisting of some 30,000 men, including 8000 cavalry. His career here has been described in the article SHENANDOAH VALLEY (q. v.). After engagements on the Opequan, at Fisher's Hill, and on Cedar Creek—at which last place Early had victory in his grasp, to be snatched from it and converted into a Union triumph by the famed "ride from Winchester" which made Sheridan a major-general in the regular army—he finally drove Early up the valley, and, after scattering the remnant of the Confederate forces at Waynesboro' and holding the valley for some months, he made his way to Grant's army at the White House on the Pamunkey, which he reached, March 19, 1865.

With Sheridan's cavalry at his disposal, Grant now began his final campaign. Sheridan crossed the Peninsula to the James and occupied Dinwiddie Court-house. Immediately on his arrival there Grant sent him word that, instead of raiding on railroads, he should "push round the enemy and get on his right rear." "I now feel," he added, "like ending the matter." So soon as Lee detected this purpose, he gathered up all available forces from his intrenched line and placed them under Pickett and Johnson, who on March 31 attacked Sheridan at Dinwiddie with a heavy infantry force. Next day, having been re-enforced by Warren's corps, he, by a masterly tactical movement, entrapped and completely routed Pickett and Johnson at Five Forks, capturing several thousand prisoners, 4 guns, with many colors. This overthrow of Lee's right, followed immediately by the carrying of all the outer line of intrenchments at Petersburg, made the evacuation of this place and the abandonment of Richmond imperative, Lee's only line of retreat being that of the Appomattox river. Next morning the blowing up of the Confederate iron-clads and the firing of the tobacco warehouses by Ewell's rearguard gave intimation to the Union troops of "the beginning of the end." Lee now began his retreat to Appomattox, Grant pursuing on the south of the river, with Sheridan on the van. On April 6 Sheridan, supported by the Second Corps, struck Ewell at Sailor's Creek, capturing 16 guns and 400 wagons, and detained him till the Sixth Corps came up, when a combined attack resulted in the capture of 6000 prisoners. This was the last serious fight in the war. On the 8th he captured four supply-trains at Appomattox Station, and at the Court-house the advance of Lee's army was resisted till dark. On the morning of the 9th the enemy endeavored to break through his dismounted cavalry, when, drawing aside, he disclosed the infantry behind. Mounting his men, Sheridan was about to charge, when the white flag was displayed, and the war in Virginia was at an end.

Sheridan was not permitted to participate in the pageant of march and review of the Union armies at Washington on May 30. Immediately on Lee's surrender he was despatched with a cavalry and infantry force to Sherman in North Carolina, but was recalled on Johnston's capitulation. He was next put in command of the forces west of the Mississippi, and despatched to Texas, where Kirby Smith was keeping up a show of resistance. Here Smith's surrender did away with the need of his services. In 1865 he was appointed to the command of the Military Division of the Gulf, embracing Florida, Mississippi, Louisiana, and Texas, with headquarters at New Orleans, with command of a corps of ob-

servations on the Rio Grande to watch the war in Mexico.

In his *Personal Memoirs* Sheridan asserts that, going beyond the letter of his instructions and perhaps even beyond their spirit, he made such demonstrations of hostility against the Austrian Archduke Maximilian, whom the French emperor was thrusting upon a reluctant people, as compelled the withdrawal of Marshal Bazaine. The dismal tragedy of Querétaro, on June 19, 1867, brought to a terrible end the vain dream of the European adventurers. Sheridan returned to New Orleans to take up the task of supervising and directing the reconstruction of civil government among a people still infected with rebellious notions. The President and Congress were at hopeless feud over the methods of restoring civil order. Though the former was his military superior, Sheridan's love of the Union for which he had dared and wrought so much made him instinctively recoil from aiding to restore power to those who had sought to divide the nation. He therefore obeyed the directions of Congress, and ruled with a rigid hand. He removed from their offices the mayor of New Orleans, the governor of Louisiana, and the governor of Texas. Finally, in August, 1867, Pres. Johnson, finding his policy thwarted by his subordinate, removed Sheridan from the command of the Fifth Military District, and transferred him to the Department of the Missouri, with headquarters at Leavenworth. Here Sheridan was brought into contact with another problem of government, of which he had had some experience at the outset of his military career—the Indian question. He solved it in the way which has commended itself to the judgment of most military men—by insisting on the complete submission of the Indians. The tribes on the plains had been left much to themselves during the long civil war, and were greatly disturbed by the rapid westward movement of white adventurers at its close. Conflicts were frequent, and both parties were in the wrong. But Sheridan, after a year's experience, determined on the most effective course to settle the troubles. In October, 1868, calling to his aid the gallant cavalry general, George A. Custer, he sent him against the villages of the Cheyennes and other tribes on the Washita. There, on Nov. 27, Custer, with the Seventh Cavalry, amid a heavy snow-storm which impeded the movement of the Indians, almost totally annihilated their bands. This expedition, though sternly denounced by many, put a stop to the Indian troubles for a time.

Sheridan continued in command at Leavenworth till, on Grant's inauguration, March 4, 1869, he was promoted to lieutenant-general, and given command of the Division of the Missouri, with headquarters at Chicago. During the Franco-Prussian war Sheridan visited Europe and was received with high distinction by King William, witnessing several battles, including Gravelotte and Sedan. In Chicago, in 1874, he was married to Miss Jane Rucker, daughter of Maj. Gen. Rucker, who had just left her convent-school in Philadelphia. During the political disturbances in Louisiana, in 1875, Sheridan was ordered to New Orleans, where he exhibited the same courage and prompt decision which characterized his whole career. On quiet being restored he returned to his command at Chicago.

On Nov. 1, 1883, Gen. Sherman was, by his own request, relieved of the command of the Army of the United States, and General Sheridan, being appointed to succeed him, removed to a home in Washington purchased for him by Chicago friends. In May, 1888, Congress passed a bill reviving the rank of General, thus enabling the President to confer this rank on him, which was forthwith done.

Already in that month the illness, heart-failure,

which was to carry him off, showed itself on his return home from a tour of inspection in the West. In the end of June, to evade the intense heat of Washington, he embarked on the U. S. steamer *Swatara*, and was by it conveyed to Nonquit, Mass. Here he died, Aug. 5, 1888, leaving a widow and four children. His remains were brought back to Washington, and, on Aug. 9, interred in the National Cemetery of Arlington. "under the shadow of the home of the Lees," with the solemn ritual of the Catholic Church, of which he was a member, and with every manifestation of public respect.

Of Sheridan, almost more than of any general in the war, it may truthfully be said that he was "a born soldier." His aptitudes were all essentially military. He was daring, enterprising, self-reliant, prompt, resourceful, and no man was more highly gifted with the faculty of inspiring his men with an enthusiasm akin to his own. The affection with which they regarded him found expression in the sort of pet name by which they spoke of him—"Little Phil." Yet no man could be more stern on occasion, and none was more stringent in enforcing discipline. With all his Irish ardor of heart, he never omitted to provide for emergencies, nor ever entered into an engagement without looking out for means for securing a retreat. His tactical ability was evidenced by the high state of efficiency to which he brought every body of troops intrusted to him; and the independent engagements he fought, and especially his conduct of the campaign in the Shenandoah Valley, abundantly testify to his skill and ability as a general. "As a soldier," Grant said of him, "there is no man living greater than Sheridan. He belongs to the very first rank of captains, not only of our army but of the world. I rank him with Napoleon and Frederick, and the great commanders of history."

Toward the close of his life Sheridan, following the example of his chief, spent much time in preparing his *Personal Memoirs*, which appeared in November, 1888. They are marked in a striking degree with the same characteristics as Grant's *Memoirs*—straightforward simplicity and terseness of thought and style, entire freedom from vanity or envy, just appreciation of the merits of others, and intense love of his country and its institutions.

(J. H.)

SHERIFF. A county officer, representing the executive or administrative power of the state within his county. In England the sheriff was formerly elected by the inhabitants of the county, except in some counties where the office was hereditary, and in Middlesex, where the office is vested in the City of London by charter. Since the statute of 22 and 23 Vict., c. 21, § 42, the sheriffs are nominated by the Lord Chancellor and judges of the courts at Westminster, and appointed by the Crown. In the United States they are usually elected for a term of three years, subject, however, to removal by the governor of the State for cause. Like other officers of the States, they are required to give bonds to the commonwealth conditioned for the faithful performance of their duties, without fraud, deceit, or oppression. The sheriff must preserve the peace of the county, and in so doing may apprehend and commit to prison all persons breaking the peace, or may bind them over to keep the peace; he must pursue and take all murderers, felons, and rioters; must keep the county jail, and defend it against rioters. To all these ends he may summon the inhabitants of the county, or *posse comitatus*, to his assistance; all persons over fifteen years of age are bound to answer this summons under pain of fine and imprisonment. He is bound to execute, within his county, all civil process issuing from the courts,

such as serving of writs, etc.; should he be a party to the proceeding, the coroner acts as his substitute; he also summons the jury which tries the cause, and executes the judgment of the court. In criminal cases, also, he arrests and holds the accused, summons the jury, and executes the sentence imposed by the court. He has power, generally prescribed by statute in the several States, to summon juries for special purposes, such as the execution of writs of damages, or of partition of lands, etc., referred to him by the courts.

His authority is confined to his own county, though when commanded by a writ of *habeas corpus* he may convey a prisoner out of his county; a prisoner who has escaped from his custody may also be pursued by him into another county and retaken there; he may also perform merely ministerial acts in another county of his State, e.g., making out a jury panel or assigning a bail bond, etc.

He may appoint deputies to assist him in the performance of his duties, and is responsible for their acts in so doing. They may perform all ministerial duties, such as the service and return of writs, etc., but any quasi-judicial duty, such as the execution of a writ of inquiry, cannot be performed by deputy. The sheriff is generally the custodian of the county jail, and is responsible for escapes therefrom; he is bound to have a sufficient force at hand to protect it from attacks by mobs, etc.

Civil process, writs, etc., are, as a general thing, served by his deputies, though it is not absolutely necessary that they should be, if the deputy is present. In serving civil process, he may not break into a man's house, though in the execution of criminal process he may, after demanding admittance. Process of any description may not be served on Sunday, except in cases of treason, felony, or breach of the peace; nor may he on that day retake a prisoner who has escaped. (T. R.)

SHERMAN, a city of Texas, county seat of Grayson Co., is on the Houston and Texas, the Texas Pacific, and the St. Louis, Arkansas and Texas Railroads, 65 miles north of Dallas. It has a fine court-house (costing \$85,000), a jail (costing \$95,000), a fine opera-house, and two large hotels. There are 2 banks, 2 daily and 3 weekly newspapers, 9 churches, 7 schools, some of which have fine buildings. There are 2 iron foundries, 4 planing-mills, and some small factories. The buildings are chiefly of brick. The city has water-works, and a park, and is lighted with gas and electric light. It was settled in 1846 and incorporated in 1853, and its prosperity has been increased by the railroads, which transport hence grain and cotton. The population in 1860 was 6093, and it is now estimated at 10,000.

SHERMAN, JOHN, statesman and financier, was born, May 10, 1823, at Lancaster, Ohio, being the eighth child of the Hon. Charles R. Sherman, judge of the Supreme Court of Ohio, who in 1810 had married Miss Mary Hoyt, of Norwalk, Conn. When John was but six years old his father died, leaving his widow with eleven children in straitened circumstances. In boyhood John was adopted by a relative of the same name living at Mount Vernon, Ohio. Here the boy received an education which he himself characterized as "the foundation-training of his life." At the age of 12 a sister took charge of him, and placed him at an excellent school in Lancaster, which he left in 1837, reasonably prepared to enter the sophomore class in college. Circumstances did not permit his carrying out this plan and after serving as a rodman in the corps of engineers engaged on the Muskingum and as superintendent of the section of the work at Beverly (whence he was removed in 1839 on account of his being a Whig), he entered the law-office of his brother, the Hon. C. T. Sherman, at Mansfield, who took him, after four

years' study and practice of law, as a partner. Here he practised for ten years, acting as attorney for all the railroads centring in Mansfield. In 1848 he married the daughter of the Hon. James Stewart, of that city, and in the same year attended the Whig convention at Philadelphia that nominated Gen. Zachary Taylor for President. In 1852 he was delegate to the Baltimore convention that nominated Winfield Scott. In 1855 mainly in consequence of his attitude on the Missouri Compromise question, he was elected to the 34th Congress in the interest of the Free Soil party. Here his familiarity with affairs and readiness in debate made him a power both on the floor and in committees. He was re-elected to the 35th Congress, and here, as in the 34th, he took a leading part in questions affecting finance, the extension of slavery to Kansas, the navy-yard abuses, etc., so that at the end of his second term he was recognized as the foremost man in the House. In 1858 he was re-elected to the 36th Congress, and in 1859 was made Republican candidate for Speaker, but yielded, after 8 weeks' balloting, to Mr. Pennington. He was then made chairman of the ways and means committee, where his zeal in the cause of the unity of the country and of sound finance, as well as against the spread of slavery, brought him into collision with Pres. Buchanan. In 1860 he was again chosen to Congress, but on the resignation of Senator Chase he was elected to his place, and took his seat in the Senate in 1861, being acknowledged as a leader from the first. On the fall of Fort Sumter he tendered his services to Gen. Patterson, and remained as his aide-de-camp, with the Ohio regiments, till Congress met in July. On the close of the extra session he raised a brigade of 2300 men, largely at his own expense, which was known during the war as the "Sherman Brigade." During the war he was mainly engaged on questions of finance, his speeches on State and National banks being the most important, while he powerfully aided the Union by steadily contributing to supply the means for continuing the struggle. After its close, Thaddeus Stevens and Sherman were the authors of the bill for the reconstruction of the Southern States which Congress enacted in the winter, 1866-67. In the latter year he introduced a refunding act, which was adopted in 1870, without the resumption clause. In 1874 he was chairman of a committee of nine, appointed by a Republican caucus, that agreed upon a bill for the resumption of specie payment on Jan. 1, 1879. In March, 1877, Senator Sherman was appointed by Pres. Hayes secretary of the treasury, and six months before the date fixed for resumption he had accumulated \$140,000,000 in gold, and saw the legal-tender notes so rival gold in value that on the day fixed for resumption there was no demand for gold in exchange for them. In 1880 he was a candidate for the presidential nomination, his vote ranging from 90 to 97, when his supporters combined with those of Blaine to nominate Garfield. In 1881 he returned to the Senate, and was re-elected in 1887, and served as chairman of committees on foreign relations, finance, expenditure, and rules. In 1888 his name was presented to the Chicago Convention as a presidential candidate, and he continued to be the leading nominee until the last day, when Gen. Harrison was nominated.

Without being a great orator, John Sherman is largely indebted for the eminent position which he has attained to his conscientious mastery of every matter with which he undertakes to deal, and to the power of lucid statement which such a mastery enables a man of vigorous, clear, and well-ordered mind to attain. Among the services rendered by him to his country may be enumerated: The reform of the abuses in New York custom-house and

in the National navy-yards, the resumption of specie payment, and the funding of the public debt. His whole career in Congress was conspicuous for scrupulous care for the public credit, and the economy of its funds. See Rev. S. A. Bronson's *John Sherman: What he has Said and Done* (1880). In 1879 Mr. Sherman himself published his *Selected Speeches and Reports on Finance and Taxation, 1859-1878*.

SHERMAN, ROGER (1721-1793), a signer of the Declaration of Independence, was born at Newton, Mass., April 19, 1721, and taken to Stonington, Conn., two years later: his great-grandfather had settled at Watertown, Mass., about 1635. With little early education, he eagerly sought knowledge, and managed to overcome great disadvantages. He is said to have kept an open book before his shoemaker's bench for the utilization of spare moments. At nineteen he was obliged to take his father's place, and become the chief support of a large family. At twenty-two they removed on foot to New Milford, where he exchanged his trade for business enterprises. His industry, ability, and integrity won a rapid and steady rise from his humble condition. Having been early attentive to mathematics, he became county surveyor in 1745, and in 1748 began to furnish the astronomical calculations for a New York almanac. He studied law in his leisure hours, was admitted to the bar, 1754, and the next year was made justice of the peace and sent to the Connecticut assembly. In 1759 he was appointed judge of the Litchfield county court. Removing to New Haven in 1761, he became a county judge in 1765, treasurer of Yale College the same year, and in the next an assistant or member of the Upper house. This post he held till 1785, and that of judge of the superior court, 1766-89. His character and position made him a leader in the struggle for liberty. Sent to the Continental Congress in August, 1774, he was a member of many important committees, including that which drafted the Declaration. He was no orator, but his business ability, good sense, uprightness, and solidity made him respected and useful, and his congressional career lasted to the end of his life. During the war he was active on the Connecticut committee of safety, and in 1783, with Judge Richard Law, revised the State statutes. He was mayor of New Haven from 1784 to his death. As a member of the constitutional convention of 1787 he rendered very important services, taking a prominent part in the debates, and offering suggestions which were incorporated in the document. He expounded and enforced the Constitution in papers signed "Citizen," and urged its ratification in the Connecticut convention assembled for that purpose, of which he was a leading member. In Congress, February, 1790, he supported an address presented by Quakers against the African slave trade, and secured its reference to a committee. He was elected to the U. S. Senate, 1791, and died at New Haven, July 23, 1793. Macon credited him with supreme common-sense, and Jefferson declared that he "never said a foolish thing." Senators G. F. Hoar and W. M. Evarts are descended from him.

SHERMAN, THOMAS WEST (1813-1879), general, was born at Newport, Rhode Island, March 26, 1813. In 1836 he graduated at West Point Military Academy, and was appointed to the Third Artillery, with which he served in Florida till 1842, having been appointed 1st lieutenant in March, 1838. He was then assigned to recruiting and garrison service till 1846, when he was engaged as captain in the Mexican war, and for "gallant and meritorious conduct at Buena Vista" was brevetted major, Feb. 23, 1847. From 1848 till 1861 he was again on garrison and frontier duty, being specially employed in quelling the Kansas border disturbances, and in the com-

mand of an expedition to Kettle Lake, Dakota. On the outbreak of the civil war, in 1861, he was promoted to major, and to lieutenant-colonel of the Fifth Artillery, May 14, and to brigadier-general of volunteers, May 17. Till the end of June he was chief of light artillery in the defence of Washington. His next employment was organizing an expedition for holding Bull's Bay, S. C., and Fernandina, Florida, for the use of the fleet blockading the southern coast, when he was assigned to the command of the land forces in the Port Royal expedition. With a division of the Army of the Tennessee he took part in the siege of Corinth, Miss., and commanded a division in the Department of the Gulf till May, 1863, when he joined the expedition to Port Hudson, La., where he commanded the left wing of the besieging force. Here, while heading an assault on May 27, he lost his leg and was invalided till February, 1864, but in the meantime was made colonel of the Third Artillery, June, 1863. He served afterward in the command of a brigade in the Department of the Gulf, and in the southern and eastern districts of Louisiana. He was in 1865 brevetted brigadier-general U. S. Army, and major-general for "gallant and meritorious services during the war." Subsequent to the war he commanded the Third Artillery at Fort Adams, at Newport, and the post of Key West, Florida. In December, 1870, he was retired from active service for disability, and died, March 13, 1879.

SHERMAN, WILLIAM TECUMSEH, the general whose operations, more than those of any other save Gen. Grant, contributed to bring the American war for the Union to a successful issue, was born in Lancaster, Ohio, Feb. 8, 1820. He is the son of Judge Charles R. Sherman, of the Supreme Court of Ohio, and brother of Hon. John Sherman (*q. v.*). Judge Sherman's fancy was captivated by the famous Shawnee chief, Tecumseh, for he insisted on giving this name to his second son, and on this being overruled by the mother, he engrafted it into that of his third son, William Tecumseh. The father died in 1829, leaving his family in poor circumstances, and William was brought up in that of the Hon. Thomas Ewing, of Lancaster, till his 16th year, receiving his education in Lancaster Academy, where he studied French, Latin, and Greek. In 1836 he entered West Point Military Academy, where he graduated, June 30, 1840, sixth in a class of 43. "At the academy," says Sherman himself, "I was not considered a good soldier, for at no time was I selected for any office, but remained a private throughout the whole four years." He was commissioned 2d lieutenant of the Third Artillery, and served in Florida against the Seminole Indians through the winters of 1840-41. In November, 1841, he was promoted to 1st lieutenant, and was shortly thereafter stationed at Fort Moultrie, S. C., where he remained for five years, having, among others, Bragg and Keyes for companions till the Mexican war. In 1846 he was sent to California, where he found a companion in H. W. Halleck, and remained through the war as acting assistant adjutant-general till 1850, having in the meantime obtained, for meritorious services, a brevet of captain in the regular army, dated May, 1848. In 1850 he returned East, with despatches to Gen. Scott in New York, and, having obtained leave of absence, visited his mother in Lancaster, and was married, on May 1, to Ellen Boyle, daughter of his benefactor, the Hon. Thomas Ewing, then secretary of the interior. In 1851 he took up his residence as commissary of subsistence in St. Louis, where his father-in-law had a property, rendered valuable by being included in the city survey, and where he himself made some purchases, which he still retains. In 1852 he moved in the same capacity to New Orleans. Finding his pay inadequate to support his family, he

resigned his commission in September, 1853, and accepted the position of managing partner of the branch of the banking house of Lucas, Turner & Co., then opened in San Francisco. The disordered condition of that city in 1855-56 tended to paralyse business, and Sherman took active part in the Vigilance Committee. After spending some time in New York, and subsequently in San Francisco, in winding up the business, he returned to his family in Lancaster. As a means of living he in 1858 entered a law firm in Leavenworth, Kansas, but, as the business was not sufficiently profitable, he made application in June, 1859, to the War Department for occupation, and was appointed superintendent of the Louisiana Military Academy. In 1861 Louisiana seceded from the Union, and Sherman threw up his office and returned to St. Louis, where he accepted the presidency of a street railroad.

On the capture of Fort Sumter Sherman offered his services to the government. These were accepted and, June, 1861, he was appointed colonel of the 13th Infantry. In the disastrous battle of Bull Run Col. Sherman commanded the third brigade in Tyler's division, and the vigor with which he fought his four regiments and battery is demonstrated by their loss—namely, 609—the total for the whole army being computed at only 1590. The Ohio delegation in Congress urged Sherman's promotion for gallantry, and, Aug. 3, he was made brigadier-general of volunteers.

When Gen. Robert Anderson, late commander of Fort Sumter, was assigned to the Department of the Cumberland, Gen. Sherman was attached as his second in command, and was soon thereafter despatched to occupy Muldraugh's Hill, south of Salt River. Here his "home guards" deserted him, and he found himself, with barely 5000 men, confronting Breckenridge with 25,000. When Anderson was relieved Sherman was appointed to succeed him. His position was far from enviable. Most of the young men of Kentucky had joined the Secessionists, and the non-combatants were usually unfriendly. He earnestly demanded re-enforcements, and in a personal interview with Secretary Cameron at Lexington, in presence of Gen. Thomas, explained the exigencies of the situation. On Nov. 3 he telegraphed to Gen. McClellan: "Our forces are too small to do good, and too large to be sacrificed." All representations proving vain, he asked to be relieved; Gen. Buell was appointed to succeed him, and at once re-enforced. Gen. Sherman, for his impertinence, was set down as "crazy," especially for having stated to the secretary of war: "That to make a successful advance against the enemy, then strongly posted at all strategic points from the Mississippi to Cumberland Gap, would require an army of 200,000 men;" and this charge clung to him till events justified his view. In the meantime he was relegated to the command of a recruiting rendezvous at Benton Barracks, near St. Louis.

But Halleck now succeeded to the Department of the West, and Sherman was ordered to Paducah, with the charge of forwarding re-enforcements and supplies to Grant, who was moving on Fort Donelson. After the capture of this stronghold, Sherman was put in command of the Fifth Division of Grant's army at Pittsburg Landing. In the battle of Shiloh (*q. v.*) Sherman's division held the key of the position around the little church, and his conduct during all the fiercely contested conflict proved him to be possessed of genius of a high order. His division—consisting of 12 regiments infantry and 4 batteries—lost 2034 men. Gen. Halleck, who took the command-in-chief immediately after the battle, reported: "It is the unanimous opinion that Brig.-Gen. Sherman saved the fortunes of the day; he was in the thickest of the fight, had three horses killed under

him, and was twice wounded." Gen. Nelson said: "During eight hours the fate of the army depended on the life of one man. If Gen. Sherman had fallen, the army would have been captured or destroyed." And Grant himself said: "Sherman, with raw troops, held the key-point to the Landing; to his individual efforts I am indebted for the success of the battle." Of his achievements in the subsequent pursuit and advance on Corinth, Grant writes: "His services as division-commander in the advance on Corinth, I will venture to say, were appreciated by the new general-in-chief beyond those of any division-officer." For his services at Shiloh Sherman was appointed major-general of volunteers, to date from May 1, 1862.

In December, 1862, commenced that series of operations which culminated in the capture of Vicksburg. Sherman having been assigned to the command of the Fifteenth Corps, he embarked at Memphis on Dec. 20. The plan of operations was for Sherman to advance directly on Vicksburg and assault it, while Grant should follow and move on Jackson by railroad, engaging and holding the enemy's force there. Just as Sherman started, Holly Springs was attacked and surrendered, with the supplies on which the expedition partly depended; Grant was brought to a halt, and the enemy on his front hastened to re-enforce Vicksburg. Sherman, ignorant of the conditions, hurried on to play his part, and, disembarking at the mouth of the Yazoo, made, on Dec. 27, a general advance on the city, and carried the outer defences. For two days the attacks were renewed, but Vicksburg was impregnable to so small a force. Under a flag of truce Sherman buried his dead and cared for his wounded, and then re-embarked. At this juncture Gen. McClernand arrived, and superseded Sherman in the command of the right wing, which the latter announced to his men in a proclamation closing: "All good officers and soldiers will give the new commander the same hearty support and cheerful obedience they have given me. There are honors enough in reserve for all, and work enough too." The work was not long delayed. Seven days later Sherman, with the Fifteenth, and McClernand, with the Thirteenth Corps, stormed Arkansas Post, capturing 7000 prisoners, with guns and supplies. Of this achievement Grant says: "The conception was Gen. Sherman's; his part of the execution was as good as it could have been."

In March Admiral Porter made an attempt to reach the city by the intricate and artificially impeded navigation of the bayous and creeks leading into the Yazoo, and was entrapped and would have been captured but for Sherman hurrying to his relief and cutting him out. In the successive assaults till the city surrendered, on July 4th, to a regular siege, Sherman's corps bore its full part. Even after the capture its labors were not at an end. A fortnight before the surrender, Gen. Jos. E. Johnston threatened the rear of the besieging army with a large improvised force. Sherman was commissioned to deal with him, and on his approach Johnston withdrew to Jackson, Miss. This town was invested, and captured by Sherman, July 13, Johnston having evacuated it. Of Sherman's whole conduct before Vicksburg, Grant says: "The siege of Vicksburg and last capture of Jackson and dispersion of Johnston's army entitle Gen. Sherman to more credit than usually falls to the lot of one man."

After some weeks' rest for him and his men he received, on Sept. 22, a telegram from Grant calling on him to hasten to the help of Rosecrans, who had been defeated at Chickamauga. On the 23d he started with his corps, and, despite difficulties all but insurmountable and the constant opposition of the enemy, arrived on Nov. 15, where he

found Grant, now in command of the department and of the Armies of the Ohio, Cumberland, and Tennessee. Sherman was put in command of the last, and ordered to effect a lodgement on Missionary Ridge, which was held by Bragg, who was besieging Chattanooga. By incessant labor, night and day, Sherman got his army ready for action on the 23d, and, despite the position of the enemy on steeply naturally and artificially so unassailable that Bragg, deeming himself secure, had despatched Longstreet to besiege Burnside in Knoxville, the bloody ridge was carried on the 25th, and the Secession army flung back into the valleys of Georgia. Pursuit followed victory. All three armies pressed onward—Hooker and Thomas sharing with Sherman in the marching and fighting—till the Confederate army was driven out of Tennessee, when Sherman returned to Chattanooga. No sooner had he arrived than Grant ordered him to the relief of Burnside, beleaguered with 12,000 men, 84 miles off. Sherman instantly set out, but, on his approach to Knoxville, Longstreet raised the siege.

Sherman with his wearied men once more returned to Chattanooga, after a three months' campaign unparalleled in the war. His official report summarized his work as follows: "The men had marched for long periods, without regular rations or supplies of any kind, through mud and over rocks, sometimes barefooted, and without a murmur. Without a moment's rest after a march of over 400 miles, without sleep for three successive nights, they crossed the Tennessee river, fought their part in the battle of Chattanooga, pursued the enemy out of Tennessee, then turned more than 100 miles north, and compelled Longstreet to raise the siege of Knoxville, which had been the source of anxiety to the whole country."

Sherman now returned to Vicksburg, and at the close of January, 1864, organized a raid into Central Mississippi, setting out, Feb. 3d, and reaching Meridian, where he waited for General Smith to join him with 8000 cavalry. But Smith did not come. Instead of starting on Feb. 1, he did not move till the 11th, and the object of the expedition was foiled. After capturing large quantities of stores and damaging this hostile region, Sherman returned to Vicksburg. On March 12, 1864, Grant was put at the head of all the forces of the Union. The same order gave Sherman command of the Department of the Mississippi, and of the Armies of the Ohio, the Cumberland, and the Tennessee, under Schofield, Thomas, and McPherson, respectively. Soon the two parallel campaigns, with Richmond and Atlanta as their immediate objective, were set on foot. On April 10, 1864, the headquarters of Sherman's three armies were at Chattanooga, Huntsville, and Knoxville, and all were to be directed against Gen. Jos. E. Johnston, then lying entrenched at Dalton, Georgia. "Neither Atlanta, Augusta, nor Savannah," says Sherman himself in his *Memoirs*, "was the objective, but the 'Army of Joe Johnston,' go where it might."

On May 5 the general movement commenced, concentrating on Dalton, whence, on Sherman's advance, Johnston retreated—Parthian-like, striking as he retired. The fighting thereafter may be said to have been continuous, Johnston impeding the march at almost every step through a country broken, densely wooded, and entangled with brush, and by roads or tracks (where such were found) of the most miserable description, which became in wet weather—and it was often such—mere quagmires. Engagements took place at New Hope Church, Kenesaw Mountain (the hardest fight in the campaign, involving a Union loss of 2500 men), and Marietta, about which two places it was really a continuous battle from June 10 till July 3, when the enemy fell back

to Chattahoochee river. July 4 was celebrated by a battle of Thomas at Smyrna; on the 17th the Chattahoochee was crossed, and on the next day Sherman learned that Johnston had relinquished his command and Hood assumed his place. On the 20th came the battle of Peach Tree Creek, and on the 22d the battle before Atlanta, when the gallant Gen. McPherson was killed. On Aug. 12 Sherman learned that he was commissioned a major-general in the regular army, and heard of Farragut's success in entering Mobile Bay, which he regarded as a valuable auxiliary for future operations. On Sept. 1 Hood evacuated Atlanta, which was forthwith taken possession of by the Union troops. Here Sherman received the thanks of the nation communicated to him in a letter from the President, as well as warm complimentary letters from Grant and Halleck. The total loss of the Union Army for the campaign, from May 6 to Sept. 15—that is, on the march from Chattanooga to Atlanta—amounted to 31,687 killed, wounded, and missing; the loss of the Confederates was 31,979. By order of Gen. Sherman the civil population of Atlanta were required to leave the city, and this was in a great measure carried out by the exodus of large numbers to Hood at Rough and Ready—whence they were conveyed to their destinations southward.

In the beginning of October Hood began a movement westward, thus removing himself from Sherman's front. This movement was soon converted into a northerly one, Hood's object being to draw Sherman back from Georgia by assailing his line of communications and threatening Tennessee and Kentucky. The device was unavailing. Sherman, on satisfying himself of Hood's purpose, thought it sufficient to send Thomas back to Nashville to defend the line of the Tennessee and check Hood from troubling his rear, and himself prepared for his southward march to the sea. On Nov. 16 the movement began, his army numbering 62,000 men, with Maj. Gen. O. O. Howard in command of the right wing and Maj. Gen. H. W. Slocum of the left. The immediate objective point was Savannah, but the ulterior point was Grant's army before Richmond. Hood's withdrawal had left the way open to Sherman. On Dec. 13 Fort McAllister, at the mouth of the Ogeechee river, was captured, and Savannah invested by sea and land. Gen. J. B. Hardee, who occupied the city, evacuated it on Dec. 21, and next day it was formally occupied by the Union troops and the "March to the Sea" accomplished.

Savannah was now made the Union base, and preparations were made for an advance through the Carolinas to Richmond. On Feb. 1, 1865, the movement began and was continued without noticeable incident to Columbia. This beautiful town, taking fire from some burning cotton, was more than half reduced to ashes. Sherman was in no way responsible for the fact, though the citizens laid the blame on him. Hardee evacuated Charleston, Feb. 18. Sherman, on March 21 had a sharp action at Bentonville, N. C., with Gen. Johnston commanding the Confederates, resulting in the retreat of the latter with a loss of 2343, the Union loss being 1604. When at Smithfield, on April 11, in pursuit of Gen. Johnston, who had retreated on Raleigh, Gen. Sherman received news of Lee's surrender on the 9th at Appomattox Court-house.

A truce was at once arranged between Gens. Sherman and Johnston, and a convention agreed to in regard to the terms of peace. This convention, however, being political as well as military, required the assent of the government. Meantime Pres. Lincoln was assassinated, and Pres. Johnson and his cabinet, thinking that Sherman had exceeded his authority, peremptorily countermanded his action. Gen. Grant quietly visited Gen. Sherman, and then the

latter granted to Johnston the same terms that had been granted to Gen. Lee. Johnston surrendered on April 26 at Durham's Station, N. C., and the brilliant campaign, as well as the war, was at an end. On May 23, at Washington, Gen. Sherman witnessed the review of the Army of the Potomac under Gen. Meade, and on the 24th his own army was similarly reviewed. "It was," says Sherman in his *Memoirs*, "in my judgment the most magnificent army in existence—65,000 men in splendid physique who had just completed a march of nearly 2000 miles in a hostile country."

Gen. Sherman on leaving Washington returned to his native place in Ohio, where he rested for a time in the bosom of his family. On the partition of the whole country into five military divisions he was appointed to the command of the second, or that of the Mississippi (afterward the Missouri), with headquarters at St. Louis. Under the act of Congress, July 28, 1866, Grant was made general, and Sherman succeeded him as lieutenant-general, in the regular army. In October he was ordered to escort the newly appointed U. S. minister to Juarez, recently elected President of Mexico, as a significant protest against the occupation of that country by the Emperor Maximilian and French troops. Nov. 10, he embarked with the minister for Vera Cruz, and, after considerable search for the headquarters of the patriots, having, as he thought, sent him *en rapport* with Juarez, returned to his duties in St. Louis. In January, 1868, Sherman was president of a board to compile a code of Articles of War and Army Regulations, the other members being Gens. Sheridan and Anger. On Grant's inauguration as President in March, 1869, Sherman was appointed general of the Army of the United States. This office he held till he reached the age prescribed by law for the retirement of army officers. He was relieved, at his own request, Nov. 1, 1883, and was succeeded by Gen. P. H. Sheridan (*q. v.*). He then took up his residence in St. Louis, but afterward removed to New York City.

Gen. Sherman's qualities as a soldier have been thus tersely summed up by one well competent to judge. "Above all his other excellences shone his promptitude, celerity, and immeasurable activity. What for some commanders were winter-quarters were to him a bivouac. Always ready for the start, indefatigable on the march, omnipresent in battle, relentless in pursuit, Gen. Sherman made himself not only more feared but more respected by the enemy than any general in the national armies save, perhaps, the one who commanded them all."

(J. H.)

SHIELDS, CHARLES WOODRUFF, Presbyterian divine, was born at New Albany, Ind., April 4, 1825. He graduated at Princeton in 1844 and studied theology there. After a brief pastorate at Hempstead, L. I., he became pastor in Philadelphia in 1850, where he remained until, in 1865, he was made professor in Princeton College. His department was the relation of religion to science, and to this was afterward added modern history. He has been an advocate of liturgical worship and of the union of Christian churches. He published *Philosophia Ultima* (1861), and several works, historical and critical, on Presbyterian liturgies.

SHIELDS, JAMES (1810-1879), general, was born in 1810 in Dungannon, County Tyrone, Ireland, and came to this country when 16 years old. In 1832 he settled at Kaskaskia, Ill., and began practice as a lawyer; and was elected, in close succession, member of the legislature, auditor, and, in 1843, judge of the supreme court. In 1845 he was made commissioner of the U. S. land office. When war was begun with Mexico he was appointed a brigadier-general and given command of the Illinois contingent; was shot through the body at Cerro Gordo, and

won the brevet of major-general. He took part in the operations in the Valley of Mexico, and was again severely wounded at Chapultepec. Mustered out in 1848, he was offered the governorship of Oregon Territory, but declined it on being elected U. S. Senator from Illinois. After serving from 1849 till 1855 he removed to Minnesota, and, on its being constituted into a State, returned to the senate as its representative. In 1860 he settled in California. On the outbreak of the civil war he was nominated brigadier-general of volunteers, and in 1862 commanded at the battles of Winchester and Port Republic, in the Shenandoah Valley. Resigning his commission in 1863, he settled first in California, but soon after at Carrollton, Mo., where he resumed his law-practice. He was also a member of the State legislature in 1874 and in 1879. He died at Ottumwa, Iowa, June 1, 1879.

SHILOH, city of Israel. See TABERNACLE.

SHILOH, BATTLE OF. This battle was fought, April 6 and 7, 1862, between the Union forces under Gen. U. S. Grant and the Confederates under Gen. Albert Sidney Johnston, the object being the capture by the latter of Pittsburg Landing, on the west bank of the Tennessee river, the base of Grant's contemplated operations. The battle takes its name from a log meeting-house, named Shiloh, near which the heaviest fighting took place.

On the loss of Fort Donelson, Feb. 16, 1862 (see FORT DONELSON), Gen. Johnston determined to abandon the line of the Cumberland and to concentrate his forces at Corinth, Miss., the point of intersection of the two principal Southern railroads—the Memphis and Chattanooga, and the Mobile and Ohio. At Murfreesboro' he made connection with Gen. George B. Crittenden, who brought with him the remnants of his force which had been defeated by Gen. G. H. Thomas at Logan Cross Roads, Jan. 19. On the fall of Fort Henry, Johnston had assigned the district west of the Tennessee to Beauregard, with instructions to concentrate all available forces also at Corinth, and this general, on the fall of Donelson, evacuated Columbus and constructed defences at Island No. 10 of the Mississippi and at Memphis, to check the advance of the Union forces by way of the great river.

Immediately on Clarksville's being evacuated by the Confederates it was occupied by Gen. Grant and Commodore Foote, who set about making preparations for an assault on Island No. 10 and Memphis. But Grant appeared to move with less alacrity than Halleck required, and the result was an episode that threatened to check a brilliant career. Irritated at a seeming disregard of his orders, Halleck reported to Washington that Grant had left his post without leave, and the consequence was that he was ordered to remain in arrest in Fort Henry and give over his command to Gen. C. F. Smith. The arrest lasted but a week, whereupon Grant proceeded to Savannah to resume the leadership of his command, which had advanced hither under Smith. He found himself at the head of six divisions—the three he had with him at Fort Donelson, increased by those of Gens. Sherman, Prentiss, and Hurlbut. On the 14th Smith (then in command) had sent Sherman up the Tennessee to Eastport, to destroy the railroad communications there, but he, finding this impracticable, returned and landed at Pittsburg Landing on the west bank of the river, and found Hurlbut already there. This landing is 8 miles above Savannah, and had been indicated by Halleck as a place of rendezvous whence to make raids on the railroads. Corinth lay 26 miles S. W. Grant, judging it unsafe that his forces should be thus divided, assembled three other divisions around the landing, and stationed the sixth, that of Lew Wallace, 5 miles down the river at Crump's Landing. Nelson,

with the advanced division of Buell's force, arrived at Savannah on the evening of the 5th, but did not arrive opposite the landing till the evening of the first day of battle, when it had to be ferried over. Before the battle Grant had at the landing a force of some 33,000 men. His neglect to intrench Pittsburg Landing in the face of a more powerful enemy has been severely criticised.

We turn now to the proceedings of the Southern commanders. The delay of four weeks, due to the divided ambition and hesitation of the Union generals, had enabled them to revive their men's courage and re-gather and re-enforce their dispersed armies. On March 23 Johnston and Beauregard had effected a junction at Corinth, and their united forces amounted to over 40,000. Johnston's plan of campaign was to concentrate his whole force before the great bend of the Tennessee, and, this effected, to crush Grant before the arrival of Buell. When he heard on the 3d of April that Buell was in motion from Columbia, he at once decided to strike the crushing blow ere the junction could be effected. The following letter to Jeff. Davis, written on the 3d, explains not only his motive but the disposition of his troops: "General Buell is in motion, 30,000 strong, rapidly from Columbia . . . to Savannah . . . Confederate forces, 40,000, ordered forward to offer battle near Pittsburg, all converging to-morrow near Monterey or Pittsburg. Beauregard second in command; Polk, left; Hardee, centre; Bragg, right wing; Breckenridge, reserve." The Confederate advance was carried out as projected, except that the difficulties of the roads caused the loss of a day. On the evening of the 5th they bivouacked in the forest, in front of and within two miles of their enemy. No suspicion of their proximity dawned on the mind of any Union general. General Grant himself, who was at headquarters at Savannah, wrote on this same 5th to Halleck: "The main force of the enemy is at Corinth."

The Union position was strong. It had the Tennessee on its left flank, which was further protected by gun-boats. The ground was easy to defend, consisting of undulations intersected by numerous streamlets and ravines, and—save for a few clearings of from 20 to 80 acres—covered with wood, partly brush and partly forest trees. It is bounded on the south by Lick Creek, which enters the Tennessee 2½ miles above the Landing, and on the north and partly on the west by Owl Creek, an affluent of Snake Creek, and then by that stream till it falls into the river a half-mile above the Landing. From the swampy nature of the banks an attack could be made only in front. The rivers and creeks enclosed a high triangular plateau with sides three or four miles in length. Two roads from Pittsburg to Corinth run along the main ridge, and from these a network of minor roads diverged to various points. Two miles from the Landing, on the western Corinth road, stood Shiloh meeting-house, which marked the centre of the battle-field and was the key to Grant's position. The disposition of the Union troops was as follows: Sherman held Shiloh; Prentiss was to his left, with McClelland to his right somewhat in the rear. Half-way back toward the Landing were the divisions of Hurlbut and of Smith (the last commanded by W. H. L. Wallace, Smith lying sick at Savannah). On the extreme left was Stuart, with one brigade of Sherman's division. Gen. Lew Wallace's division was at Crump's Landing. Grant had thus 33,000 men in line between Owl Creek and Lick Creek. Accounts indicate somewhat of a gap between Sherman's left and Prentiss' right.

The Confederates stood deployed for the attack in three lines. The Third Corps and one of Bragg's brigades formed the advanced line, reaching from Sherman's right to beyond Prentiss' left, and numbered 9024 men. Bragg's remaining five brigades,

numbering 10,731, stood about 800 yards behind Hardee and leaning more to the right, as far as Stuart. Polk's four brigades and Breckenridge's three were disposed right and left as reserves. In all Johnston had about 40,000 men.

At 5 o'clock on Sunday morning, April 6, the Confederate lines moved to the attack. The time required to pass the two intervening miles, and skirmishes between the pickets and a reconnoitring regiment, put the Union front on the alert, and when the lines came together the divisions of Sherman, McClelland, and Prentiss were in position to offer stubborn resistance. It would be vain to attempt to follow the vicissitudes of the fight, which, beginning at dawn, lasted till sunset. It has been characterized by Grant as a conflict between Southern dash and Northern pluck and endurance. There were onset and repulse without cease, but through all fluctuations the Confederates won their way northward, in accordance with which, Beauregard, to whom Johnston had committed the general direction of the fight, advanced his headquarters from point to point. Early in the day the divisions of Hurlbut and W. H. L. Wallace had been brought forward to sustain Prentiss, Sherman, and McClelland. It was in the afternoon that the most noteworthy incidents occurred. First occurred the death of the Confederate commander Johnston, who fell heading the charge of a brigade. About 3 o'clock the withdrawal of troops produced gaps both on left and right of Prentiss and Wallace, and the enemy were not slow in seizing the advantage. They enveloped them. Wallace was mortally wounded and Prentiss was captured, along with the fragments of both divisions to the number of 2200.

This capture left a break in the Federal line, and, but for one compensating circumstance, would probably have given the victory to the Confederates. The Union lines had been swept back a mile and a half, and the attack was advancing on the Corinth road running along the principal ridge. Col. Webster, of Grant's staff, foreseeing that the enemy were on the eve of gaining the ridge, gathered what guns he could, and posted a line of artillery of 35 to 50 pieces along the ridge, manning it with cannoners largely extemporized from stragglers. The guns on the boats co-operated with those on the ridge. The turning-point was now reached. Before Webster had succeeded in beating back the last desperate onset, Nelson's division was mounting the bank from the river and deploying in line. All chance of a Confederate victory vanished. The attack ceased over all the line.

During the night Crittenden's division of Buell's army, was placed in position, and McCook's reached early on Monday morning. Buell, who had arrived on Sunday evening in advance of his vanguard, directed the posting of his divisions, which amounted in all to 20,000 men. Lew Wallace, with his division, numbering 6500, had arrived from Crump's Landing, and was stationed on the right.

Grant and Buell now agreed to take the offensive next morning, and by a simultaneous onset drive the enemy from the field. The two wings of the combined army advanced steadily, and by 3 p. m. were in possession of all the ground they had lost, while the enemy was in full retreat on Corinth. The Union generals made no attempt at pursuit, but contented themselves with an advance sufficient to assure them the enemy had disappeared. Thus ended, after a struggle of two days, the bloodiest battle that had yet been fought on American soil. The Federal loss was 1754 killed, 8408 wounded, and 2885 missing. Gen. Beauregard reported a loss of 1728 killed, 8012 wounded, and 957 missing. Both sides claimed the victory; but the Confederates failed in the object they aimed at.

SHIP-BUILDING. The vessels in which Columbus made his first voyage to America were the Santa Maria, the Pinta, and the Nina. The Santa Maria was about

100 feet long, 29 feet wide, and 12 feet depth of hold, with a single deck. The Pinta and Nina were much smaller, open like boats, but with cabins and quarters built at the stern and bow for the officers and crew. They had two masts, the forward one carrying a square sail, and the after one a triangular sail, attached to a yard, hanging by its middle at an angle of about 45° with the horizon.

Ship-building in America, as with all other countries, was brought about by the fisheries. Cabot, in 1497, having spread the news that the shores of North America were teeming with fish, many expeditions were sent out, and in a few years both France and England had hundreds of fishing vessels catching fish off the banks of Newfoundland, and curing and salting them on the island. By 1600 England was sending more than 200 vessels annually, and fully 10,000 persons were employed in catching and curing fish, and as explorers pushed in toward the shores of what are now Massachusetts and Maine, they found that better fish could be caught in shallower water than off the Banks, and the desire to found fishing colonies was one of the strongest motives leading to the grant by James I., in 1606, to the Plymouth Company.

The vessels sent to fish were very small as compared with the vessels of the present day which cross the Atlantic. Not more than 15 per cent. of the vessels of England, in 1582, were more than 75 feet long by 23 feet wide by 10 feet depth. In 1603 England had few vessels of more than 400 tons burden.

The coast from Newfoundland to Virginia was soon dotted with little fishing villages. The English merchants did not wish to go to the expense of carrying a large number of men on their vessels, and these fishing villages were places where the men could be left permanently to dry the fish, and by their numbers be secure against attacks from the Indians.

The colonists soon began to build boats and fish for themselves. This was not at all relished in the mother country, and in 1670 orders were issued to capture and burn the boats and break up the boat fisheries of New England. This was not effectual, and soon vessels were carrying fish for sale to Virginia and the West Indies, and finally to Europe, and whalers were penetrating to the icy regions north and south. The vessels taking out cargoes of fish came back loaded with the commodities of the countries visited, and vessels gradually were drawn into regular trade, the fishing fleet being at hand to furnish masters and men. A valuable commerce was in this way brought about, and the demand for vessels stimulating ship-building, it became a fixed and prosperous industry within a hundred years of the time of the first permanent settlement.

The first ship built in this country was the Virginia, built at the mouth of the Kennebec River, in 1607. A party came to found a fishing settlement, and the two ships bringing them over returned, leaving 45 persons behind. The winter being very severe, they were discouraged and built the Virginia to take them home again. She was a well-built little vessel with two masts, about 60 feet long by 17 feet beam by 10½ depth of hold, and made several voyages across the ocean. The next vessel built was the Onrest, 44½ feet long and 11 feet beam. She was built by Adrian Blok at New York, in 1615-16, to replace one of the Dutch vessels that had been burnt. She was used for several years in exploring the Atlantic coast.

No other vessels except boats appear to have been

built until 1631, when, on July 4, the vessel *Blessing* of the Bay was launched at Medford for the use of the Massachusetts colony. Gov. Winthrop wished to send a vessel to open communications with the Dutch at New York, and for trading with other places. She was used for some time, and then was probably wrecked.

The fact that timber was rapidly being exhausted in England was a strong inducement to British merchants to import timber and, later, to build vessels in America. Matthew Craddock located a claim and established a ship-yard on the Mystic River. Several large vessels were built there and sent to England. The ship-building industry seemed to thrive in Salem from the first, and the village soon became noted for its ship-yards and the vessels built therein. Before 1640 the transatlantic trade was mostly carried on in European vessels, but in that year a vessel of 300 tons was laid down at Salem for a company, with the Rev. Hugh Peters at its head, and a vessel of 150 tons was begun at Boston, both vessels being launched the following year; and in 1641-42 three vessels were building at Salem, three at Boston, and one at Dorchester. The success of these vessels started a ship-building industry, a number of New England towns began to build vessels for foreign service, and the merchants of Barbadoes, Antigua, and Jamaica sent to New England for their vessels.

Ship-building was early engaged in by the settlers of Connecticut, and sloops and other small vessels were built along the Connecticut River, especially at New Haven, from the white-oak, chestnut, and pine which abounded in that vicinity.

The Dutch West India Company encouraged ship-building at the mouth of the Hudson by granting special privileges to take timber from the forests to build ships, though most of the work was done at the ship-yard of the company. After New York passed into the hands of the English, ship-building was continued. In 1669 a vessel of 120 tons was built at New York, and one of 65 tons at Gravesend, L. I. In 1700 there hailed from New York 124 vessels of 100 tons and under, and from Boston 194, among them vessels of 300 tons. About this time the shipping of New York was much injured by the war then waging between France and England, and for many years after the ship-yards only turned out small sloops, the main ocean carrying being in European bottoms.

Most of the building during colonial times was done in New England. In 1698 an act was passed providing for the inspection and registry of vessels of 30 tons and upward. The colonial archives in Boston show that of the vessels registered from 1698 to 1714, 1332 were American built, 239 of them for foreign owners.

The vessels of those days, while small, carried large crews and usually were armed; thus the ship *Richard*, of 100 tons, carried 14 men and 12 guns; the *Prudent Sarah*, 100 tons, 14 men and 10 guns. The magnitude of the ship-building industry just prior to the Revolution can be understood from the following: In 1769 the Colonies built and launched 389 vessels, 113 square-rigged, and 276 sloops and schooners, of an aggregate burthen of 20,000 tons. Of these Massachusetts provided nearly one half, New Hampshire and Rhode Island the next largest number, while New York had only 5 square-rigged vessels and 14 sloops and schooners. Pennsylvania owned 1344 tons, Virginia 1249 tons, North and South Carolina 1396 tons, Connecticut 1542 tons, and Georgia one sloop and one schooner whose combined tonnage was 50 tons.

In this same year the entrances to the ports of the United States amounted to 332,146 tons, and the clearances to 339,302 tons, of which 99,121 tons cleared for England, 42,601 for Southern European

and African ports, 96,382 for the West Indies, and 101,198 for the rest of America. The aggregate value of all the imports was £2,623,412, and of the exports £2,852,441, of which Great Britain sent £1,604,975, receiving in return £1,531,516.

During the revolution the fishing and whaling fleet was nearly annihilated by the British cruisers lying off the coast, and ship-building was suspended. The idle fishing and merchant fleets were employed in privateering. The first privateer built was by a Newburyport merchant, and she took 23,360 tons of shipping, and 2225 men, the vessels and cargoes selling for \$3,950,000.

Four frigates and three sloops-of-war were built for Congress, familiarizing our people with the building of large, powerful vessels, and these were followed by large privateers as private ventures of the merchants of Philadelphia, New England, and Baltimore. In consequence of this, there were many vessels at the end of the war that were too large for the coasting trade, and they entered into competition with the rest of the world, especially for the East Indian trade. The first ship carrying the new flag to enter Canton was a Baltimore vessel, and she sailed thence with a cargo of teas, china-ware, and silk. In 1788 the ship *Atlantic*, of Salem, displayed the American flag in Surat, Bombay, and Calcutta.

When in 1814 peace was declared, after the war of 1812, it was at once realized that after so long a stagnation in commerce there would be great profits to those first in the field with ships and cargoes, and within a few days after the receipt of the news all the idle yards were full of busy workmen, and from this time till 1861 our maritime career was most prosperous.

Forty years of war had led the American to design ships for speed and handiness, and our builders carefully studied the models and rigs to attain these qualities. Clumsy shapes and looks were discarded, and our vessels were models of beauty and were capable of developing great speed.

While ships naturally took the shape best fitted for their special trades, the tonnage law also had an effect on them, as the tonnage was computed from the length and breadth measured on deck, and the depth was taken as one-half the beam. In consequence of this the length and breadth on the upper deck were kept as small as possible, the bow was lengthened out on deck, and the sides bulged out at the water-line, so that the tonnage, estimated from the deck measurements, was less than the actual tonnage. Roomy ships were obtained, but the government did not get its just dues, as ship-builders courted the reputation of building the roomiest ship on the least official tonnage measurement.

A special class of ships, carrying both freight and passengers, came into existence just after the War of 1812, to meet the demand of the great ocean travel then beginning, and to carry the great number of emigrants to America. Such vessels usually barques and ships, were most luxuriously fitted up, and would carry from 600 to 1000 people and 1000 tons of freight. New York was the centre of the packet business, and the Black Ball line was started by Isaac Wright & Co. just after the War, sailing twice every month to Liverpool. This line was soon followed by others sailing to London and Havre. There was a strong spirit of rivalry among the various lines, and this led to a study of the principles of ship design and construction. Our builders not only studied all that was to be learned from foreign books, but conducted experiments with models. The shape of swift fishes was studied, and the behavior of water and the influence of different dispositions of sails were fully investigated. Such study and experiment placed our ship-builders ahead of others, and our models were copied the world over

by ship-builders. As a result of the years of study from 1812 to 1850 the American sailing-vessel reached perfection, and practically no advance has been made since then.

Till 1849, the packet was a one- or two-decked vessel, with poop and topgallant fore-castle, of an average register of 1000 tons. Freight was stowed in the lower hold. Between decks the cabin passengers were stowed aft, the middle portion was devoted to cooking and pantries, and the steerage passengers and crew were quartered forward.

The first three-decker, the *Guy Mannering*, was built at New York in 1849, by Wm. H. Webb. She was about 190 feet long, 40 feet beam, and 29 feet depth of hold, and of 1419 tons register, and would carry 2400 tons of freight on a draught of 20 feet. This noble ship set the fashion, and the three-decker was from this time the popular type of packet ship. Our ships carried the finest officers and crews of any vessels afloat, were well built and well sailed, and being fast and comfortable, they drove the vessels of other nations from the field and had a practical monopoly of passenger, mail, and express traffic. Excellent time was made. The *James Baine* sailed from Boston to Liverpool in 12 days and 6 hours, and the *Red Jacket* from New York to Liverpool in 13 days 7 hours; but the average time was, of course, greater, about 20 days to Liverpool and 32 to return.

English steamers began to compete with the packet lines about 1840, the Cunnard line beginning that year, supported by a subsidy of £90,000 a year, soon increased to £145,000. The United States started the Bremen line in 1847, and the Collins line in 1850, but in 1857 all subsidies were withdrawn, and ships of these lines were taken off. The civil war of 1861 was the final blow to our packet ships. This packet period is noted for the great increase in size of vessels. In 1714 ships were in the China trade of only 200 tons burthen, and our present lumber schooners would have been considered immense vessels; but about 1812 large vessels began to be built, and from that time on the increase in size is most remarkable. About 1825 the *Washington*, of 1000 tons, drew crowds of people to the wharves in all the ports she visited. In 1841 the largest merchantman in the world was built and launched at Bath, by Clark & Sewall. She was called the *Rappahannock*, and though of light scantling, lasted twenty years.

The packet ship was followed by the clipper, since cargoes that deteriorated on the voyage had to be carried, and the changing character of the markets made speed as important for freight as for passenger traffic. The clippers of 1840-50 sat low in the water, with sharp bow, fine water-lines, tall masts, with enormous spread of canvas. The first clipper ship was built by Wm. H. Webb in 1841, for the China trade. She was the *Helena*, of 450 tons. She was built for speed, and fully realized the expectations of her builder. The discovery of gold in California gave a great boom to the clipper ship, as everything that could be bought in the East was sent to California by freight, and our yards turned out vessels the largest and finest that the world had ever seen.

The years 1854-5-6 are noted for the number and beauty of the vessels built in the United States. In these first years of the California gold fever \$40 per ton of 40 cubic feet was paid from the East to New York, and ten years later it was \$25.

The first clippers had sharp floors, considerable drag, with a full forward and a lean after-body. This was gradually changed, the vessels of 1840 being made fuller on the floor, and with a more even keel, but the hollow water-line and long bow were retained. These clippers made excellent speeds. The *Red Jacket* once made 325 miles a day for a

week, and the *Sovereign of the Seas* once made 437 miles in 24 hours. The average time was about 7 knots per hour. (See CLIPPER SHIPS.)

In 1847 a first class vessel cost here about \$80 per ton against \$90 in England.

Many new appliances were due to the clipper-ship competition, such as double topsails and various devices to save labor, such as steam saw-mills, derricks, etc. Labor was divided, too, as the early ship carpenter was a Jack-of-all-trades and would do all the work, from hewing out the frames to canking the seams. But this practice was not found to yield the best results, and separate gangs of men did the carpentering, canking, fastening, painting, etc., leading to better and quicker work. About 1835, when the supply of oak timber grew small in New England, Southern timber began to find its way into the Northern yards. Forests of magnificent white oak were growing in the peninsulas of Delaware, Maryland, and Virginia. The moulds or patterns were made for the frames of a vessel, and parties of men were sent into the woods in the winter, where they camped, and felling the trees, hewed the frames from them and carried them by rafting or other means to some place where they could be loaded upon schooners, to be taken to the Northern ship-yards. The frames of vessels built along the New England coast are still obtained from the forests in the States named.

Southern pitch-pine was used for beams, decks, and waterways, clamps, etc., and in time came to be used for the ceiling and planking of vessels. For the masts and spars white pine and spruce are preferred, though lower masts are made up often of oak, maple, or yellow pine, dowelled, bolted, and hooped with iron.

The coasting trade and the California wheat trade to Europe still employ a large number of sailing ships. Sailing ships are still more profitable for long voyages with certain classes of cargo than steamers, and many such are built, though the number of large vessels will gradually reduce each year, as the steam engine becomes more economical in coal consumption.

The tonnage and number of sailing vessels built during the last five years is as follows:

	Number.	Tons.
1884.....	780	134,187
1885.....	582	74,723
1886.....	475	50,986
1887.....	545	50,376
1888.....	584	76,080

Before 1861 the schooner had come to stay as the coasting vessel. Fewer men are required with this rig, and it can be worked in and out of harbors more easily than the square-rigged vessel. On account of the shallow harbors and sand-bars of the eastern coast the greater number of the Atlantic coasting schooners have flat bottoms, and are fitted with centreboards. The lines are free, the beam large, and the bow sharp and long. For ocean voyages and for the Pacific waters most of the schooners are built with keels. In our coasting trade schooners are used to transport lumber, coal, ores, and ice, and for fishing purposes. The yards in Maine still turn out a number of large schooners each year. The *Governor Ames*, built in 1888 at Waldeboro, is one of the largest schooners afloat. The length on the keel is 232 feet, over all 265 feet, beam 50 feet, depth 21 feet, lower hold 13 feet, between decks 8 feet. She has a tonnage registry of about 1800, and will be able to carry about 3000 tons of coal on a draught of 20 feet. In her construction 460 tons of Virginia white-oak are used in the framing. The planking is 6 inches thick, at the gunwale $7\frac{1}{2}$ inches, the heaviest planking ever put on a schooner. The centre board is 33 feet long, 15 feet deep, and 9 inches thick, made of white-oak. One

hundred and fifty tons of bolt iron are used in her fastenings. She has nine cargo hatches, 25 feet across. The most striking point about this great schooner is her rig of five towering masts, designated respectively the foremast, mainmast, mizzenmast, jiggermast, and spankermast. The five lower-masts are each 115 feet long and 30 inches in diameter. The topmasts are 56 feet in height. The jibboom is 75 feet long and 22 inches in diameter at the bowsprit-cap. She will spread 63,000 square feet of canvas.

The building of whaling vessels, now almost discontinued, was once a great industry in New England. These vessels were not large, as a rule not exceeding 400 tons register. The largest whaler was the George Washington, of 600 tons. The earlier whalers, built for use and not for show, were clumsy to look at above water, but under water the model was usually very good, being sharp on floor and ends, deep, and with the greatest beam forward of amidships. Of late lighter sterns and more shapely bows have been introduced, and the whaler looks as neat as any of her sister vessels of the merchant fleet. No material except the very best, and that without flaw of any kind, was put into a whaler by the builders of New Bedford, New London, and Sag Harbor. Every detail was carefully looked out for with a care not known in any other branch of ship-building. Especial care was taken in calking the seams, and the vessel was often hauled down on one side to open the seams on the other for calking. The George Howland and the Roman, calked in this way, sailed for eighteen years without recalking. The result of careful building is shown in their longevity, vessels being serviceable seventy-five years after building. The scantlings and fastenings of whalers are in the main heavier than are required by underwriters for insurance in the merchant navy.

Steam-whalers have lately come into use. In 1879 the Mary and Helen was launched at Bath, Maine. She is 133 feet long, 30½ feet beam, registers 420, carries a full spread of canvas, and has a screw engine capable of driving her from 6 to 8 miles an hour. She is built of oak, yellow pine, and hackmatack, and cost \$65,000. Since then several others have been built.

The sailing fishing fleet of the United States is large, and many different classes of vessels are used, which cannot all be described here. The rig and shape of boat is such as is best adapted to the peculiar conditions of service required, ranging from the Chesapeake Bay canoe and bug-eye to the fishing schooners of the North.

Steam Navigation.—After the invention of the steam-engine, efforts were made to use it for locomotion on land and sea. The greatest need at that time was to tow vessels when entering or leaving harbors, and to propel boats on canals and against river currents. Jonathan Hulls patented a stern-wheel boat in England in 1736 to be used for harbor towing. In America John Fitch built a vessel to run on the Delaware in 1785-87. This was fitted with banks of vertical oars on each side, a beam carrying the oars being attached to a crank from the engine situated in the boat, dipping the oars in the water, moving them aft, lifting them out and forward, to repeat the first motion. This was America's first steam-boat, and a speed of from 4 to 7 miles was obtained. James Rumsey tried forcing a current of water from a pipe at the stern by steam-power. Fitch in 1793 made the first experiment with the screw propeller. The boat used was about 18 feet long by 6 feet wide, with a screw wheel at the stern, worked by a horizontal, walking beam engine with a wooden cylinder at each end of the beam. The cylinders were made like barrels and the boiler was only an iron pot with

a wooden lid. A speed of 6 miles an hour was obtained.

The men, however, who made steam-navigation a success were John Fulton, with his partner Livingston, and John Cox Stevens, of Hoboken. Fulton and Livingston made their first experiments on the Seine, at Paris, building two small boats in 1803 and satisfying themselves as to the feasibility of steam-propulsion.

Stevens worked on screw propulsion for thirteen years, and in 1804 built a boat, the Phoenix, 25 feet long, driven by a Watt's engine and screw, obtained a speed of 4 miles an hour, and finally took the vessel by sea from Hoboken to the Delaware, the first ocean steam-voyage.

Fulton bought a 20 horse-power engine in 1806, and came to America to start steam-navigation, his original idea being to build boats for the Western rivers; but when he, with Livingston, obtained exclusive rights for steam-vessels on the Hudson, all their efforts were then made in that direction. His boat, the Clermont, was built on the East River, in 1807, by Charles Brown. She was at first 133 feet long, 16½ feet wide, and 7 feet deep, but was afterward made 141 feet long by 22 feet wide. She had a flat bottom, straight sides, a full bow, and a straight stem. A bottom was laid of 1½ inch yellow pine, tongued and grooved and set with white-lead, and floors laid across this, 24 inches apart, made of oak of 8-inch square section under the machinery, but at the ends of spruce, 4 by 8 inches in section. The boat was decked only at the ends, and the boilers were in full view. The paddle-wheels were 15 feet in diameter, with buckets 4 feet long and with 24 inches dip. The shaft was of cast iron, 4½ inches in diameter. A heavy fly-wheel was at first carried, 10 feet in diameter, but as this extended down into the water it was inconvenient in shallow water, and was afterward removed.

The boiler was 20 feet long, 7 feet deep, and 8 feet wide. The engine cylinder was 24 inches in diameter by 4 feet stroke. The boat drew 28 inches of water.

On the first trip 110 miles were made in 24 hours, and 150 miles in 32 hours; or, deducting stops, in 28½ hours, an average of 5 miles per hour.

While the first trial of this vessel was looked upon with the greatest interest, the satisfactory introduction of steam-navigation brought about the enmity of the numerous packet lines carrying the freight and passenger traffic. Sloops would make the trip from New York to Albany in 27 hours, the passenger fare being \$5, and they lost no opportunity to annoy the Clermont, even going so far as to wilfully run against her to smash the paddle-wheels. However, after being lengthened, in 1810, as stated above, she made many successful trips, always running full of passengers. In 1808 Charles Brown built the Raritan and the Car of Neptune. In 1812 a ferry-boat was built to run to the Jersey shore. The double-ended ferry-boat, drooping at each end, so familiar to the American travelling public, was designed by Fulton and has been but little modified since.

Steam-boats quickly sprang into existence in other parts of the world, after being proven a success by Fulton. One was built on the St. Lawrence in 1809, and another in 1811. The British built their first steam boat at Glasgow in 1811, and boats were soon building all over the kingdom. Builders were enabled to put in the necessary plant to build marine engines on account of contracts for steam men-of-war, and by 1839 England had 96 such vessels.

The war of 1812 did not interfere with the development of the steam-boat in this country. Fulton proposed to the government to build a steam warship, the first in the world, to steam at 4 knots per hour and to carry guns pointing in every direction,

for \$320,000. The offer being accepted, the vessel was built in 1814. She was 156 feet long, 56 feet wide, and 20 feet deep, drawing 10 feet of water. The paddle-wheel, for protection, was hung in the middle of the hull; it was 16 feet in diameter, the buckets 14 feet long, with 4 feet dip. Her tonnage was 2475. The boiler was 22 feet long by 12 feet broad by 4 feet deep, the cylinder 4 feet in diameter by 5 feet stroke. She made a speed of 5½ knots an hour, and was a most formidable vessel. Her magazine blew up in 1829, destroying the vessel.

In 1809 the first race on the Hudson took place between rival boats, Fulton's boat beating. For many years nearly all the steam-boats were built by Charles Brown, but the industry soon spread, and vessels were built at Newburg, Philadelphia, and Baltimore.

To Robert L. Stevens the Hudson is principally indebted for its steamers, as he carefully studied the conditions of river navigation and led off in engine improvements and in making the ends of vessels long and sharp. Old boats were lengthened and some had false bows put on; while some of the vessels built after 1830 had solid ends, so sharp and so well designed that they parted the water with scarcely a ripple, and lately such vessels as the *Mary Powell* have attained speeds of 25 to 28 miles an hour.

To traverse Long Island Sound boats were built broader and deeper than the river boats, as they experienced rougher weather. The *Rhode Island*, built in 1836, was 212 feet long and 28 feet wide.

Fulton started with the paddle-wheel, and it is used to this day for river navigation, but the screw, being much better adapted for deep-sea service, has entirely superseded the paddle-wheel in ocean-going steamers. The invention of the screw is directly connected with the story of the advance of ship-building.

As our earlier boats built for river traffic used the paddle, developments were in that direction, and but little attention was given to the valuable experiments of Fitch and Stevens. But in England they needed something different from the paddle, as the paddle, being often out of the water during rolling and pitching, was not suited to ocean work, and in 1825 a premium was offered for the best device for propelling vessels other than by paddles. A naval officer invented a screw with two blades, and one or two boats were fitted with it. This caused more attention to be devoted to the subject, and in 1836 patents were taken out by F. P. Smith, of London, and John Ericsson. Smith's screw was a spiral wrapped about an axis, and having been tried on a small boat, a larger vessel, the *Archimedes*, 125 feet long, was built, fitted with a screw 5 feet 9 inches in diameter and 8 feet pitch, the blade making a complete turn round the axis, this being shortly replaced by two blades making half-turns. The Smith screw was not commercially successful, but the world owes to John Ericsson the development of a new and successful method of propulsion.

The first practical screw vessel was the *Francis B. Ogden*, built in 1837, and named after the U. S. consul at Liverpool, who had perceived the advantages of Ericsson's screw. This boat, 45 feet long, was fitted with two screws, 5 feet 3 inches in diameter, consisting of a hub of iron around which were placed several plates having a spiral twist. This little boat, drawing 2½ feet of water, developed a speed of 10 miles an hour, and towed a schooner of 170 tons at 7 miles an hour. The Admiralty refused to encourage Ericsson, however, as it was held that vessels could not be steered with such an arrangement.

Capt. Robert F. Stockton took a trip on the *Thames* in the *Ogden* in 1837, and at once gave an order for two iron boats fitted with the Ericsson

screw. One of these, the *Robert F. Stockton*, was launched in 1838. She was 70 feet long by 10 feet beam by 6½ feet draught. She had two propellers in line, 6½ feet in diameter. She made 12 knots an hour. The vessel was rigged as a schooner and sent to America under sail under the command of Capt. Crane, with a crew of four men and a boy, being the first iron vessel to cross the Atlantic. She was sold in 1840 to the Delaware and Raritan Canal Company, and her name changed to the *New Jersey*. She was used as a tug for several years.

Capt. Stockton having introduced the screw into America in this way, and its advantages being recognized, it at once sprang into favor, and in less than ten years 150 screw vessels had been built in America. It was through Stockton that Ericsson gave up his engagements in London and came to America. The government concluded to fit one of the war-ships authorized in 1839 with an Ericsson propeller, and the *Princeton* was so fitted, the machinery being placed below the water-line, the first war-vessel of this class in the world. She was 164 feet long, 30½ feet beam, and drew, with outfit and 200 tons of coal, 19½ feet. She had flat floors amidships and a sharp bow and stern. The stern post was 26 inches thick where the screw shaft passed through it, tapering above and below. The stern overhanging 15 feet, and hanging from it was a wrought-iron rudder-post, heeling on an oak extension of the keel, leaving a space of 6 feet between the stern and rudder-posts. The screw was made of a brass drum 8 feet in diameter, fitted with six brass blades having a helicoidal twist, extreme diameter 14 feet, pitch 35 feet, length in direction of the axis 2 feet, and weight 12,000 lbs. The vessel made 13 miles an hour. The cost was \$212,000.

The iron tug *R. B. Forbes* was built at Boston in 1845. The first tug fitted with screws, built at Philadelphia, was built by Wm. Cramp in 1849, the engine being made by Jacob Seafie. This tug was of wood, 80 feet long by 17 feet wide by 8 feet deep. The screw up to this time had been placed below the keel, but Mr. Cramp, seeing the disadvantage of this, gave the tug *Sampson* a six-foot screw, extending 3 feet below the hull, with a keel built down aft to protect, and in a short while he made another step in advance and placed the screw above the keel in the position where it is placed to this day.

The English still adhere mainly to the paddle-wheel tug, but the handy American screw tug-boat is undoubtedly superior. The average tug is about 90 feet long by 18 feet wide by 9½ feet deep. They are sharp and deep, draw about 8 feet of water, having low free boards and considerable sheer forward. The machinery is covered by a house, with a pilot-house at the forward end. Strong towing bits are placed forward and aft.

The first steam-vessel to cross the Atlantic was the *Savannah*, built by Crockett and Fickett, at New York, in 1819. Originally intended as a sailing packet, she was rigged as a ship, a 90-horse-power engine placed between decks, with boilers in the hold, and was fitted with paddle-wheels. In May, 1819, she was taken by Capt. Moses Rogers to Savannah, and on May 25 started thence to Liverpool, making the passage in 25 days, during 18 of which she was under steam. The *Savannah* was not a fast boat, and her machinery was finally taken out, and she was wrecked on Long Island. However, she showed to the world what could be done in steam-navigation, and England at once began to develop this part of her mercantile marine and navy. She granted subsidies to lines to various points, and by giving contracts for a number of steam men-of-war enabled ship and engine builders to put in the expensive plants necessary for this sort of work.

The screw propeller made its first appearance in

the coasting trade in 1841, on the *Clarion*, built for the service between New York and Havana. Philadelphia, however, was much more energetic in developing the screw than New York. The fact that our builders did not develop the screw but kept to the paddle was one of the reasons that our merchant marine suffered with the coming in of the steam-vessel. The greater part of the capital was then in New York. The engines of the larger vessels, like those for the *Pacific Mail*, were built at the Novelty Works in New York, and having the patterns for the engines and all the necessary drawings of paddle-ships, they were naturally averse to building screw steamers. These works passed into the hands of the Brown Brothers, the bankers, who controlled a large interest in the *Pacific Mail*, and in this way the building of large paddle steamers for ocean navigation was kept up. The immense paddle-shafts that had to be imported from England were constantly breaking, making the expenses of such vessels beyond their earnings.

On March 3, 1847, Congress authorized the secretary of the navy to contract for a mail steam-ship service once in two months, or oftener, from New York to Chagres, on the Isthmus of Panama, and from Panama to Astoria, touching at Monterey, San Diego, and San Francisco. The Atlantic branch was called the *United States Mail*, and the Pacific branch the *Pacific Mail*. Three ships were built for each line, all wooden paddle-wheel steamers, with wheels from 33 to 36 feet in diameter. While the three ships of the *Pacific Mail*, the *California*, *Panama*, and *Oregon*, were on their way to the Pacific, the news of the discovery of gold in California reached the East, and when the *California* arrived at Panama an excited crowd of people was there waiting to be taken to the north.

While the gold fever brought into existence the great clipper ship, it also gave an impetus to the construction of steamers, as the trade on the Pacific reached in one year a magnitude beyond twenty years' ordinary development, and, a steam-fleet being needed, steamers were built one after the other. In the course of the next ten years the two lines spoken of above had alone built 29 fine vessels of 38,000 tons registry, costing about \$8,300,000, and in those ten years the vessels of these lines carried 175,000 persons to California, and brought back \$200,000,000 in gold. The vessels became larger and larger, wooden vessels attaining sizes up to 3300 tons register in 1861; the *Golden City*, of 3373 tons, built in 1864, was 343 feet long and 45 beam.

The steamers of the two principal lines were built in New York, and ship-yards lined the East river. Wm. H. Webb having as many as a thousand men in his yard. The New York builders attained a world-wide reputation, and obtained orders for war-ships from Russia, France, Italy, Portugal, and Turkey, among them being the General Admiral, the iron-clad frigates *Re d' Italia* and *Re Don Luigi de Portugal*, each of 3700 tons, and the iron-clad ram *Donderberg*, of 5090 tons, 380 feet long and 75 feet beam.

In the four cities of New York, Philadelphia, Boston, and Baltimore there were built from 1830 to 1861 about 80 sea-going steamers, with an aggregate tonnage of about 120,000, and costing about \$29,000,000. Five-sixths of this tonnage was built in New York. The first large American ocean steamer was the *Massachusetts*, sent out from Boston in 1844, with a screw propeller as an auxiliary power.

The *United States*, built in 1847 by Wm. H. Webb, was intended to be a New Orleans packet, but was eventually sold to the German Confederation for war service. She was 256 feet long by 40 feet beam by 39½ feet deep. For 50 feet at each end, the frames, deadwood, and keelsons were of live-oak, locust, and

cedar; amidships the lower timbers were of Southern white-oak. There were five rows of yellow-pine keelsons amidships, 3 feet deep, and four rows 16 inches deep. The bilge streaks were 12 inches square. This boat throughout was exceptionally strong, and the manner in which the large structure of wood was tied together, in this and similar vessels, gives evidence of the great skill and experience of the ship-builders of this date. This vessel had full floors with but little dead rise, and a sharp bow and run. Her model is about that of the sea-going American steamers of to-day, though a longer, sharper bow is built with iron vessels.

In 1845 the postmaster-general was authorized to contract with Mr. Edward Mills for 20 trips a year to Europe for the sum of \$400,000, and in 1847 the Washington and the *Hermann* began to compete with the English steam-ship lines, which were rapidly obtaining the advantage over our sailing vessels. These vessels were long, square-sterned three-deckers, with side paddle-wheels about the middle of the length, bark rigged, and with a full allowance of sails. They were very good sea boats, but were beaten in time across by the *Cunarders* from two to three days.

In 1850 the *Franklin* and *Humboldt* were built for the same service, but were put on a line to Havre. About this time the idea of a line to Liverpool took shape, as our capitalists and ship-builders, who had so easily kept in the lead in the days of the fast packets and clippers, did not like to see the English absorb our carrying-trade, and only asked to be put on an equal footing with the English shipping men that they might again take the lead. Mr. Edward K. Collins originated and carried through the idea of placing American ships on a line to Liverpool, to surpass the English vessels running to that port from America. Under the laws of 1845 a contract was made with Mr. Collins whereby he was to build and run four steamers from New York to Liverpool, to make twenty trips a year and to carry the mails, the line to receive \$385,000 a year. These vessels were to be suitable for war purposes. The *Cunarders* then running were from 1140 to 1500 tons register. All the Collins boats were about 2800 tons, each of the best materials and workmanship, and supplied with unusually powerful machinery. They were the pride of America, being the largest and fastest steamers then afloat. The four steamers first built were the *Arctic* and *Atlantic*, built by Wm. H. Brown, of New York, under the inspection of George Steers, and the *Baltic* and *Pacific*, built by Brown & Bell, of New York. The machinery was built by the *Novelty* and *Allaire Works*, of New York.

The details of construction of the *Arctic* and *Baltic* are as follows:

Length on main deck, 282 feet; depth under spar deck, 32 feet; beam, 45 feet. The frames were white oak and chestnut with tops of locust, live-oak, and cedar; stanchions and timber-heads of white oak; apron, breast hooks, and inner stern-post of live-oak; keel of white oak, 18 by 20 inches. The frames were double-sided 24 inches and moulded 21 inches over the keel; the lower futtocks were sided 12 inches; all other timbers, 10 inches. The spacing was 30 inches amidships, increasing to 36 inches at the ends, with the floors filled in solid to the turn of the bilge. The ceiling-clamps and water-ways of the lower decks were of yellow pine, the fine bilge streaks 12 inches square, bolted through the edges every 4 feet; the clamps of the lower deck, 8 inches; upper deck, 7 inches. The garboards were white oak, 15 inches wide, 9 inches thick, copper-bolted through the edge with 1-inch bolts every 3 feet and with two bolts through each timber. The rest of the outside planking was of yellow pine, 5 to 7 inches thick and 6 to 8 inches wide. The main keelson was white oak, 32

by 34 inches. The side keelsons under the engines were white oak, 22 by 42 inches; elsewhere, of yellow pine. The beams were mainly yellow pine, excepting some white pine in the spar and orlop decks; the lower and main deckbeams, side 12 to 14 inches, and moulded 13 inches at the centre and 10 inches at the ends; the spar deck beams, 6½ by 8 inches at the centre. The decks were of white pine: orlop deck 3 inches, lower deck 3½, main 4, and spar deck 3. The bulwarks were 3-inch white pine. The knees were white oak and hackmatack. The hull was square, fastened with two ¼-inch copper bolts and two locust treenails to a draught of 20 feet; above that, galvanized iron and treenails were used. The frame was strapped with iron crossing amidships like lattice-work, with a spacing of 4 feet. There were two side lever engines: cylinders, 95 inches in diameter, 10 feet stroke. There were four tubular boilers, 22 feet long by 14½ feet high, two of them 14 feet wide and two 15 feet wide. The hull weighed about 1525 tons, and masts and rigging 34 tons. On a draught of 19½ feet forward and 20 feet aft 2000 tons of freight and 250 passengers could be carried.

The service began with these vessels in 1851, and they beat the Cunarders from the start by about one day. They enjoyed the confidence and the patronage of the travelling public, and in eight years from the time they began passenger traffic increased fivefold. From January to November, 1852, they carried 4306 passengers to the 2969 who went by the Cunard Line, and their competition reduced the cost of freight to Liverpool from £7½ to £4.

The Cunard Line at once began to put on larger and faster steamers. Collins' mail allowance was made \$858,000, and greater speed was required of him, and he met the requirements. Unfortunately, the Arctic was lost in 1854 and the Pacific in 1856. In 1855 the Adriatic, of 4144 tons, was built, at a cost of \$1,100,000. She was 345 feet long by 50 beam by 33 feet depth. She made a trip in 1861 from Saint John's, N. F., to Galway in 5 days 19½ hours.

Beginning in 1853, the feeling against subsidies was awakened, and it continues to this day; while, as a matter of fact, the granting of subsidies is a business-like application of statesmanship, and its continuation would have kept us in the front rank in the transatlantic trade, and could not have failed to have been of the greatest value to our ocean commerce, our ship-builders and ship owners, our people and our country. In 1857 the Collins mail contracts expired, and the government refused to renew them; Mr. Mills suffered in the same way.

The English were then paying \$866,700 a year to the Cunard line, and smaller sums to other lines, and as Mr. Mills and Mr. Collins could not compete with England's treasury they were forced to withdraw and sell their ships, and the United States deliberately turned over the vast mail, express freight, and passenger business of this country with Europe to foreign ships. In 1856 Mr. Vanderbilt started a line to Havre, but soon gave it up. During the civil war the foreign lines got a very strong foothold. In 1866 an American line was formed in Boston, and two large oak-built screw steamers, the Erie and Ontario, were started to run between Boston and Liverpool. The English steamers immediately cut rates, and soon the American ships had to be withdrawn. A line was afterward started from Baltimore in connection with the B. & O. R. R., but had only a brief existence.

An American steamship line was started in 1873 to run from Philadelphia to Liverpool, and it still lives; but few American lines have been started at other points. The coasting lines, such as the Clydes and the Red D, have extended their trade to Cuba and Mexico. Commodore Garrison ran a few wooden steamers from New York to Brazil after the war, sided

by a subsidy, and John Roach ran a line of steamers from 1878 to 1881. The Pacific Mail has sent steamers to the Sandwich Islands, Japan, China, and Australia.

America is renowned for nothing more than for her river steam-boats, the necessities of internal navigation developing this class of vessels earlier than ocean steamers. As the Mississippi and its tributaries drain a region of 1,250,000 square miles in extent, embracing nineteen States rich in products of every kind, and several growing Territories, using the streams as commercial highways, it is natural that there should be a great demand for vessels to traverse them. Certain restrictions were put upon builders by the character of the rivers to be navigated, owing to the light draughts necessary. The western boats are marvels in the way of light-draught construction, as there are vessels which on six feet draught of water carry 2000 tons of freight. These boats, to ascend the river against strong currents and to tow a large number of barges, must be fitted with engines of great power, and the weight of the engine has been greatly reduced on this account. The walking beam and the condenser was soon dispensed with, the engines being so placed as to act directly on the paddle-shaft. The earlier steamers were mostly side wheelers, but after 1850 the stern wheelers came into favor, and they now outnumber the side wheelers three to one.

Fulton and Livingston in 1811 built at Pittsburg the stern-wheel boat Orleans, of 200 tons, rigged with masts and sails. She used wood for fuel. She was strongly framed, but had no guards or upper works. She arrived at New Orleans, Jan. 10, 1812, for the first time. She made about three miles an hour. After running as a packet between New Orleans and Natchez for about two years she was sunk by a snag in 1814. Before this the navigation had been by flat-boats, pushed along with poles or long sweeps, or by small sail-boats. The availability of the steamer was at once apparent, and they were built rapidly from this time on. The stern-wheeler Conet, with vibrating engines, was built in 1813, and ran to New Orleans, where her machinery was sold to a cotton factory. The Vestuvius was built at Pittsburg by Fulton in 1813, and a small steamer of 50 tons was built at Brownsville, on the Monongahela, in 1814, and the same year the Etna, of 200 tons, was built at Pittsburg. The Washington, the first boat with two decks, was built at Wheeling. The machinery, which in previous boats was in the hold, was in her brought up on deck, where it is still placed in the boats now in use on the western rivers.

Preceding boats had such low-power engines that they could only be employed on the lower Mississippi and Ohio when the current was less than three miles an hour, and they could never get up the swifter rivers after having once gone down. The Washington, however, was a powerful boat for her day, and was able to make a round trip from New Orleans to just below the falls at Louisville and back in 45 days. Her success started the building of a number of steam-boats along the Ohio, where nearly all the earlier boats were built, and where about five-sixths of the boats of the Mississippi Valley are built now. In 1818 the General Pike was built at Cincinnati for passenger traffic. She was 100 feet long on the keel, 25 feet beam, and had a handsome cabin built on the deck between the engines. The central hall was 40 by 18 feet, with 8 state-rooms at one end and 6 at the other. She ran as a packet between Louisville, Cincinnati, and Maysville.

There were but few Eastern boats used on the Western rivers. The Maid of Orleans, of 100 tons, was sent from Philadelphia in 1818 and went up the river as far as Louisville, being the first vessel to reach that city from an Atlantic port. She was a two-masted

schooner, with auxiliary steam-power for use on rivers.

Up to 1818 the fastest trip from New Orleans to Louisville was made by the Shelley, the time being 19 days. She carried 51 passengers, a cargo of groceries and dry goods, and stopped at ten places *en route*. The usual time was from 25 to 30 days. The fast steamer Cincinnati made the round trip in about 40 days. After 1830 determined efforts were made to improve the speed, and in 1838 the Diana ran from New Orleans to Louisville in less than 6 days, winning a premium of \$500 from the Post Office Department for doing so.

The passenger boats were side-wheelers, built of oak, framed and planked much the same as sea-going vessels. They had flat floors and sharp bows, and drew from 4 to 6 feet, and were from 400 to 600 tons register. The cabin was between the engines, the upper cabin becoming popular later.

When fast boats became the rage there was a fierce rivalry, and racing was very common. Boats were sent over the course stripped of every possible weight that could be dispensed with, and without cargo of any kind, driven at the full power of the engines, simply to beat previous records and establish a reputation for speed. Until legislation regulated the strength and pressure of boilers, this passion for fast time led to great loss of life and property on account of explosions.

From 1830 to 1840 the favorite size was about 150 tons, but after 1840 larger boats began to make their appearance, and a departure was made in the use of lighter scantling and different construction from sea-going vessels. The Sultana, built in 1843, was 250 feet long, 35 feet beam, and 8 feet hold. There were seven boilers, 32 feet long and 42 inches in diameter. The engines were 30 inches by 10 feet stroke, the paddle-wheels 30 feet in diameter, with 14 feet buckets. She developed a speed of 15½ miles an hour, and made one trip from New Orleans to Louisville in 4 days 22 hours.

In 1852 the Eclipse, one of the largest boats built in the West, was built at New Albany just below the falls. She cost \$300,000 and was sumptuously fitted up with a richly furnished saloon, with a steering cabin on top. There were 8 boilers, 32½ feet long by 42 inches in diameter, and two engines: cylinders, 36 inches by 11 feet stroke. The paddles were 41 feet in diameter. Her light construction will be seen from the size of her scantlings. The frames were single, and were cut from 4 and 4½ inch fitch-oak, moulded 13 inches on the floor, 10 inches at the bilge, and 5½ inches at the head. The main keelson was 12 by 16 inches, the bilge log 7 by 11½ inches, and there were 18 floor keelsons, ranging from 3½ by 10 inches to 4 by 11 inches. Fore and aft wooden bulkheads were put in to strengthen her. She was planked with 3½ to 4½ inch oak. She was for many years the most popular and fashionable boat of the West. Her greatest speed up the river was 16 miles an hour, and she often made 25 miles an hour down stream.

The Shotwell was built in the same year. She was a sharp boat, built for racing, and in 1853 she raced the Eclipse. Both vessels were stripped for the race and carried neither passengers nor freight. Furniture, landing stages, and fenders were left behind, and even the bulkheads in the wheel-houses and parts of the decks were removed. The Shotwell, on account of being shorter, could turn the bends

more quickly, but she ventured too close and got aground, losing 2½ hours, and thereby the race. The Eclipse made the trip from New Orleans to Louisville in 4 days 9 hours and 30 minutes, having lost 35 minutes during the race by blowing out the packing of a piston. A number of large, swift steamers followed those boats, ranging from 250 to 300 feet in length, fitted up in the most comfortable and beautiful manner. These boats were usually owned in Pittsburg, Cincinnati, and Louisville.

The civil war interrupted the river traffic, and a good many of the older vessels disappeared. But after the war new steamers appeared, superior even to the old. Two of these were the R. E. Lee, built in 1866, and the Natchez, in 1869. The Lee was 300 feet long, 44 feet beam, and 10 feet deep, with engines 40 inches by 10 feet stroke, the paddle-wheels being 38 feet in diameter, with 16½ feet paddles. The Natchez was 301½ feet long, 42½ feet beam, and 9½ feet in the hold. Her engines were 34 inches by 10 feet stroke, paddle-wheels 42 feet in diameter, with 16 feet paddles. In 1870 these two boats raced from New Orleans to St. Louis, 1200 miles. They were stripped for the race and ran at about 17 miles an hour, were in sight of one another most of the way, and only an hour apart at Memphis and Cairo. The Lee arrived at St. Louis in 3 days 18 hours and 14 minutes, and the Natchez arrived 6 hours and 33 minutes later.

A great number of boats have been built of late years. A description of the City of New Orleans will give a very good idea of the construction generally in use. She is 300 feet long, 48 feet beam, 83 feet over the guards, and 9 feet hold. Her draught, with machinery, coal, and water on board, is 30 inches forward and 42 inches aft. The frames are single, 9 by 4 inches, spaced 15 inches; main keelson, 21 by 9 inches; eight floor keelsons, 9 by 4 inches; four wing keelsons, 7 by 12 inches, to receive the heels of the stanchions and the hog chain braces; bilge keelson, 6 by 12 inches; planking, 4 inches on the bottom, and 4, 3½, and 3 inches on the sides. The beams are 4 by 6 inches, spaced 21 inches, with heavier beams 12 by inches at the end of the boiler deck; stanchions, every other beam 6 inches square, in seven rows, with thirty extra stanchions 10 by 3½ inches under the cylinder timbers and paddle-shaft. There are three stringers on the top timbers, each side, 9 by 2½ inches. The clamps are 13 by 3½ and 12 by 3 inches. The five boilers are on deck, forward, and are 30 feet long, 44 inches in diameter, with five flues each. There are two engines, one on each side amidships, 26 inches in diameter by 10 feet stroke. The paddle-wheels are 35 feet in diameter, with 15 feet paddles. The cabins and pilot-house stand up to a great height above the water. The saloon is 220 feet long, 17 feet wide, and 13 feet high. There are forty-five staterooms, 12 feet long by 10 feet wide. This boat is for the passenger and cotton trade of the Mississippi, and on 9 feet draught will carry 250 passengers and 2300 tons of freight.

With a light-draught boat of this sort the girder formed by the structure is a shallow, and there being but little buoyancy at the sharp ends, a most elaborate system of hog and cross chains is carried out. These are long iron rods stretching from end to end and from side to side of the boat. A hog frame, such as is seen on so many of the boats around New York, is hardly ever seen in the West. The fore and aft arrangement of these hog chains is shown in the



Hog Chains of the City of New Orleans.

accompanying sketch. They fasten under the main and floor keelsons, and run up over the ends of long rows of square pine masts, set up perpendicular amidships, but inclined at the ends.

The main chain is 2½-inch bar iron, carried on 9-inch square pine braces, rising 14 feet above the main deck. The centre chain is 1½-inch bar iron, the forward end descending to the main keelson just under the after end of the boilers, the chain running back over the main braces and being brought down to the keelson again about 15 feet from the stern-post. The stern chain is 1½-inch iron, passing over one

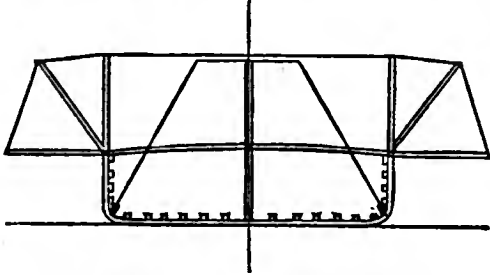

Cross Chains of the City of New Orleans.

brace. The boiler deck and bow chain is 1½-inch iron on short braces forward, as shown.

There are seven cross chains of 1½-inch iron resting on seven of the main braces, with struts as shown, giving support to the bilge of the boat; and under the boiler deck and forward there are nine more such chains of 1½-inch iron; 48,000 pounds of wrought iron are made use of in this system, and by it the guards are made sufficiently strong to carry any number of bales of cotton, the hull is kept from breaking down at the ends, and the light scantling of the West is rendered possible.

On the upper part of the Ohio, the Mississippi, and the Arkansas, and the other tributary streams of the West, the passenger, freight, and towing boats are stern-wheelers. The boats are not so wide, and for shallow-water traffic are superior to the side-wheelers. Naturally, the boats are different from the side-wheelers. The wheel-houses and guards are dispensed with, the cylinder timbers are carried aft and project about 25 feet abaft the hull proper, having a slight sheer upward. The paddle-wheel shaft rests on these timbers, and the system of hog chains is carried aft to support and distribute the weight of the wheel. The lines of the boat aft are completely changed, as there is no taper to the after-end. The after-body is carried back square, and the floor is brought up at the stern, giving an appearance of two hulls when looked at from the stern. Three or four rudders are used, the side ones hung on the upright stern-posts, while the middle ones are hung on stout rudder-posts and project partly under the boat, being balanced rudders. The passenger and freight boats of this class are handsome boats, from 200 to 265 feet long and from 35 to 40 feet beam.

The towing boats are not so large and have small cabins, but are built with very strong bows. The way in which tows are made up on the western rivers is different from the methods of the seaports, as the tow is not towed but pushed. The barges are arranged in groups, often eight or ten boats wide and four boats long, strongly lashed together, and arranged ahead and alongside the forward end of the steamer, about one-fourth the steamer being buried in the group. The deck is carried out square to the bow, ending in a strong chock for pushing. To steer such a fleet around the bends of swift rivers requires a great deal of experience and judgment. The stern-wheeler Jos. B. Williams, built at Pitts-

burg, went south from Louisville last year with a mammoth tow of 30 coal-barges, and six barges and three additional vessels, amounting to 798,434 bushels, or 33,340 tons; including fuel, 31,388 tons. This tow was 789 feet long—including the steamer, 1015 feet long—and 262 feet wide. To transport this tow by rail would require 60 trains of 25 cars each, 20 tons to the car, and would extend over a continuous line of track of ten miles.

There are four classes of barges in use on the Western rivers. The smallest is the flat-boat, about 90 feet long, 16 feet wide, and from 5 to 7 feet deep, used on small streams for short trips for carrying about 110 tons of coal, stone, or other rough freight. Next, the coal-barge, which is an open boat, strongly built, with raking ends, about 125 feet long by 25 feet wide by 8 feet deep. They are mainly employed between the coal mines in Pennsylvania and West Virginia and the markets along the river as far as New Orleans. The coal-boat or broad horn, is a flat-bottomed, square-ended boat, with a strong bottom but light sides, about 175 feet long by 25 feet wide by 9½ feet deep. The fourth is the model barge, having hulls built like steamers, sharp at both ends, decked, and sometimes having a house.

Flat-boats are built up on the sides of four or five tiers of solid white-pine logs, 6 to 8 inches thick, laid one above the other, and strongly bolted through the edges with square iron spikes, with sheer pieces on the top at each end. A number of cross timbers, about 6 by 12 inches and 12 feet apart, with the ends tenoned into the lowest log, form the side. Under these are fastened fore and aft streaks, and the bottom is then planked across with 2- and 3-inch hemlock, white pine, or oak. Iron straps are placed at the corners. Uprights are let into each end of the floor-timbers and bolted to the sides, and bitts are provided for towing. These boats cost from \$500 to \$650, the labor on one of them amounting to about \$100, using from 13,000 to 18,000 feet of lumber and 1450 lbs. of iron.

The coal-barge is simply a large barge, the side-pieces being in several pieces about 20 to 50 feet in length. It requires about 34,000 feet of lumber and 3000 lbs. of iron for one. They cost from \$1000 to \$1200, about \$190 of this being for labor. They weigh about 45 tons net, and draw about 5 inches of water light.

The coal-boat or broad horn has a barge-bottom, with one side-log about 9 by 16 inches, strengthened at the scarples by a piece inside 18 feet long, about 4 by 16 inches, fastened on with 10 large treenails, 7 or 8 screw-bolts, and a number of spikes. A row of uprights, 6 by 2½ inches, is set up perpendicularly from the side or bilge-log all around the boat, and the side planking is fastened to those. It is usually 1½-inch hemlock. A couple of threads of oakum is driven into the seams. A light clamp is nailed around on the inside of the uprights to support light beams or braces, about 4 by 4 inches, which are put in about 8 feet apart. These boats cost from \$800 to \$900, and, while having about twice the capacity of a barge, contain about the same amount of lumber.

These three classes of boats were originally propelled with huge paddle-wheels or sweeps, consisting of a heavy pole with a stout board at the end. This is no longer done, on freight barges, though the sweep-propelled boat is still met with on the Southern bayous and sluggish rivers, in the shape of flats that have been decked over and housed, and are fitted up as travelling tin-shops, blacksmiths' shops, and trading vessels.

Of the model barges there are four sizes, carrying 600, 800, 1000, and 1200 tons of cargo respectively. They are sharp at both ends, and are built about like the steam-boat hulls, but have but one hog chain, which hooks under the main keelson at the bow and

stern, and is supported on four or five pine posts. Light collision bulkheads are built at the bow and stern, and when the hold is intended for grain or packages it is ceiled up in such a manner as to form a cargo box, with an air-space of as much as two feet between the ceiling and the frames. A barge, 200 feet long, 36 feet beam, and 6½ feet hold, with a cargo box 169 feet by 33 feet by 11 feet, costs about \$9000.

The great highway of travel and trade in Oregon is the Columbia river, ocean steamers from San Francisco ascending the river as far as Astoria and Portland, numerous small steam-boats carrying freight and passengers farther into the interior. Steam-boat building was begun about 1850. The Eliza Anderson was built at Portland in 1858, and by her longevity showed the advantage of using properly seasoned yellow fir for boat-building. The earlier boats were side-wheelers, but the later ones are stern-wheelers, which are better adapted to shallow waters. The Columbia river stern-wheelers are not similar to those of the Mississippi Valley described above. The keel, forward, begins to rise 15 or 20 feet from the bow and runs into a rocker stem; aft, the stern is not separated into two parts, but the bottom begins to rise 20 or 30 feet from the rudder and nearly reaches the surface at the stern, which is cut off square above the water. Sagging is prevented by iron rods hooking into the keelsons forward and aft, running up to a line of masts, and these are screwed up till they take the weight off the bow and stern. The hulls are made of fir, the houses of white cedar and fir. The central masts are carried high up, as there are no bridges to interfere. The barges are somewhat similar to the ones described above, nearly all, however, having small houses on deck. There are small schooners on the river dealing in butter, eggs, and produce, that are fitted with small auxiliary propellers for going against tide and current.

The pioneer of the lake steamers was the Ontario, of 232 tons, built at Sackett's Harbor, in 1816, a side-wheeler, 110 feet long. The next vessel built on the American side was the Walk-in-the-Water, of 342 tons, built at Black Rock in 1818. In the following ten years twenty steamers were built on the lakes of Ontario and Erie, mostly on the American side, all side-wheel boats.

The Welland Canal was opened in 1829, and stamped a special character on lake vessels. The smallest locks were 110 feet long, 22 feet wide, and 8 feet deep. The sailing vessels were thereafter made with bluff, full forms, with round bows, flat bottoms, and straight bodies, in this way securing the greatest capacity; and steamers intended to pass through the canal approximated to the same form.

The steamers intended for local traffic kept a sharp form, and were never shallow as the eastern river boats. Many of the steamers were side-wheelers, ranging from 250 to 600 tons, occasionally larger. The engines were of the low-pressure walking-beam type, and were fitted with masts and sails for use in case of injury to the machinery.

The Walk-in-the-Water went to Detroit as early as 1818, and by 1830 steam-boats were running regularly to Chicago. The number of boats increased rapidly after the opening of the canal, and the size began to increase rapidly after 1844, a number of long, fast sharpers being built from that time on. They were built mainly of oak, the decks, houses, and spars being of white pine. They had very high and sumptuously furnished cabins. The Plymouth Rock, built in 1854, 310 feet long, and the City of Buffalo, built in 1857, were among the last of the large side-wheelers built. About 300 side-wheelers were built in all, but now not more than 3 or 4 are produced yearly, and these not above 800 tons; and

many of the old side-wheelers were converted into propellers, and others into floating docks and barges.

The Welland Canal being impassable by the large side-wheelers, and many important harbors being on rivers and canals, screws came into favor.

The first propeller on the lakes was the Vandalia, of 138 tons, built at Oswego, N. Y., in 1841. She was fitted with a mast and sail, with machinery well aft, the smoke-stack being nearly in the stern. In ten years 53 screw vessels were built, ranging in size from 150 to 700 tons. The vast freight traffic of the lakes has called for larger vessels, and the canal has twice had the sizes of the locks increased.

The vessels employed exclusively for freight are called steam-barges. These have small houses forward and aft, and sometimes as many as four masts. These barges carry coal, grain, iron ore, and lumber.

The machinery is placed aft in the lake propellers, and when not loaded the bow sits high up out of the water. This is convenient when loading, but the rough weather of the lakes strains the vessel when unloaded; so the hog frame was early adopted, and it was given the form of an arch sweeping in a long curve from end to end of the ship, the top chord made of several thicknesses of 6- or 8-inch oak breaking joints. These arches being in the way, especially in handling lumber, they have been dropped, and strength is now secured by strapping the hulls on the outside of the frames and ceiling them heavily with oak, broad arches often being bolted to the inner side of the hold timbers.

IRON SHIP-BUILDING.

The first iron boat known to have been built in the United States was the Codorus, built in Pennsylvania for service on the Susquehanna. New York led in the early iron building. In 1836 an iron vessel of 600 tons was built there. In 1838 an iron boat was built at Pittsburg, and in 1841 a revenue cutter was built at Boston, and by 1842 Philadelphia had built a line of small iron steam-boats to trade with Hartford, Conn. The iron hulls were first built by boiler-makers; there was but little shape given to the vessel, the bottom being built on a platform and the sides brought up vertical, the frames being put in last. However, the ship-builders in wood were appealed to and they soon began to put in tools for building the iron hulls; and they were not contented with box-like shapes but soon brought the lines of the iron vessel up to those of the wooden vessel. While the greatest ingenuity and mechanical skill and knowledge were shown in binding together and strengthening the hulls of wooden vessels, the great horse-power and lengths required for high-speed vessels called for a stronger material than wood, and the iron ship became a necessity. The earlier vessels were framed much in the same way as the wooden vessels, but very soon the iron vessel took a distinctive character very different from the wooden vessels. A history of iron ship-building is mainly the history of the well-known ship-yards of this country. Wm. H. Webb stands at the front as a wooden ship-builder, and the names of Cramp and Roach are known the world over as builders of steel and iron vessels. The United States has furnished many vessels to foreign governments. Wm. H. Webb built the *Re d' Italia* and the *Re Don Luigi de Portugallo* for the Italian government, the former making 14 knots on her first trial, using only four boilers out of six. Webb also built the iron-clad *Rochambeau*, now owned by France. In Boston the Atlantic works built vessels and machinery for a great many different nations and during the war turned out a number of monitors. In 1858 there was quite a movement in the direction of iron ship-building in New York. The side-wheel steamer *Suchil* was launched from Bell's yard in 43

days after the keel was laid. The Novelty Iron Works built a large iron steamer the same year, and four iron screw vessels were begun at the Morgan Iron Works. Prices, wages, and taxes are now against the building of iron ships at New York, though there are a number of large machine shops devoted almost entirely to marine-engine work. The home of the ship-builder is the Delaware—the Clyde of America. Here there is the water-front, railroad facilities, trained labor, good climate, and fresh water, with coal and iron almost within reach. It is but natural that here we should find the best ship-yards of the country. One of the earliest iron boats, after the *Codrus*, was a small barge built by Jesse Starr, half a mile from the river and hauled down to the water. The work was mainly done by the large boiler-makers, the hulls being designed and laid down on the mould-loft floor by practical ship-builders. With the earlier vessels there was a great waste of material, the plates being ordered from the girth at the greatest section, considered as carried to the ends, and the first to suggest and carry into successful execution the measurement of the sizes of each plate from a model of the vessel, upon which the plates were drawn out, was Charles H. Cramp, of Philadelphia; a great saving was effected, and this method of ordering material was at once adopted.

It was not till the beginning of the civil war, however, that Philadelphia began to forge ahead of New York; but, large ships being then needed, Wm. Cramp fitted up his wooden ship-yard with machinery capable of making iron plates and frames. The first vessel was the *New Ironsides*, an iron-clad wooden ship (see *IRONCLADS*). When first contracted for, her timbers were still growing in the woods, but she was completed in six months; and, due to the foresight of her builders, she was able to carry a much heavier battery than was first intended. The monitor *Yazoo* was built at this yard, and a great deal of other government work. The plant was gradually improved, and in 1872 a contract was entered into for the construction of four steamers for the American line for \$2,400,000. These were most excellent specimens of American workmanship, and were so well built as to obtain the most favorable rating in the English insurance companies.

After the completion of these vessels wooden ship-building was given up by the Cramps, and since that time they have built four fast cruisers for the Russian government and a number of large steamers and yachts, the best known of the latter being the *Atalanta*, *Corsair*, and *Stranger*. One of the finest freight steamers afloat, the *Herman Winters*, was built by this firm; and the twin-screw passenger steamer *Monmouth* is the first of her class, and by her success will probably cause the paddle to give place to the screw in many cases. The large coasting steamer *Iroquois* is an excellent example of a well-built, comfortable, and speedy vessel. During Pres. Cleveland's administration the secretary of the navy, Wm. C. Whitney, awarded the contracts for five vessels to the Cramps. Three of these are large, protected steel cruisers, supplied with every modern appliance in construction and armament. These are the *Newark*, *Baltimore*, and *Philadelphia*. The *Yorktown* is a fast steel cruiser of about 1700 tons displacement. The fifth vessel is the *Vesuvius*, a dynamite-gun cruiser, armed with three 15-inch dynamite guns capable of throwing projectiles containing 500 pounds of dynamite a distance of two miles. Twenty knots speed were guaranteed, and the vessel attained on her official trial trip 21.65 knots, or about 25 miles an hour.

The firm of Neffie & Levy has been engaged in the construction of iron vessels for a number of years. They have turned out many ships and a vast number of marine engines.

At Camden a number of iron lugs are built each year. At Chester is Roach's ship-yard, covering seventy acres and having a frontage of 2500 feet. Roach first bought the Morgan Iron Works of New York, and in 1872 bought the property at Chester, the first ship being launched at Chester. Vessels have been built here for the Pacific Mail, the Brazilian line, and the coasting trade; also a number of vessels for the U. S. government, a number of the small single-turreted monitors, the double-turreted monitors *Puritan* and *Miantonomoh*, and the *Chicago*, *Boston*, *Atlanta*, and *Dolphin*.

At Wilmington is the Harlan & Hollingsworth Company, which built the first iron coasting steamer in the United States. This yard has turned out many fine vessels, among them the monitors *Amphitrite*, *Patapsco*, *Saugus*, and *Napa*. All sorts of vessels, from yachts to iron-clads, have been built, among the former the victorious *Puritan*.

The Pusey & Jones Company, of Wilmington, has turned out over a hundred iron vessels, of all types, a feature being made of vessels for river traffic.

There is an iron ship-building yard at Locust Point, Baltimore, the *Columbian Iron Works and Dry Dock Company*. This yard does a great deal of repair work, and has built several large ferry-boats, and is now building the gun-boat *Petrel* for the government.

The Union Iron Works have lately been established at San Francisco, under the management of Irving M. Scott. They are thoroughly well equipped with the best modern tools, and have already entered into competition with the older yards of the East for government work, and have obtained contracts to build two large steel-protected cruisers, the *Charleston* and *San Francisco*.

There are iron ship-yards at Pittsburg and St. Louis, and on the great lakes at Buffalo, Cleveland, and Wyandotte, the lake steamers comparing favorably with vessels built in the yards on the coast. The machinery costs much less in the lake steamers, on account of being used in fresh water.

The United States has now the educated labor and the necessary plants, in private yards, to turn out vessels second to none in the world. The liberal spirit of Congress has provided the money, and the Navy Department, by insisting upon having only the best, in material, design, and workmanship, has advanced the art of ship-building in this country to such an extent that we lead the rest of the world in everything except the construction of heavy-armed vessels.

The government has ship-building yards at Portsmouth, N. H., Boston, Mass., New York, Philadelphia, Norfolk, and Mare Island, Cal. The yards at New York, Norfolk, Philadelphia, and Mare Island are to be fitted up to build iron vessels, the first two already having armored vessels to construct.

The building of the vessels for the navy comes under the cognizance of the Bureau of Construction and Repair. The head of this bureau is Chief Naval Constructor T. D. Wilson, U. S. N. The machinery comes under the Bureau of Steam Engineering, presided over by Engineer-in-Chief Geo. W. Melville, U. S. N.

The capital required in wooden ship-building is not great. Most of the workmen bring their own hand-tools, consisting of broad axes, adzes, saws, bevels, chisels, calking iron mallets and rules, the builder furnishing the large tools, such as cross-cut saws, augers, and belt cutters. In case the yard is supplied with steam, a saw-mill and planer are added. There are yards where large wooden vessels are built where the tools would not bring \$500.

With iron ships it is different; here nearly all the tools are furnished by the builder, and many of them are very expensive and require to be run by

power. A yard to build the hull of a ship of about 2500 tons in a year could be established for about \$60,000, including buildings, but a first-class modern ship and engine building establishment, capable of turning out about 70,000 tons of shipping and 50,000 horse-power, fitted with the latest and most improved labor-saving machines, will cost about \$1,200,000.

Ships cannot be built, even with the necessary plant, without plenty of money. The weekly payroll of a large establishment on the Delaware is about \$30,000, and when, with this, the large amounts spent for material, insurance, and other purposes are taken, it will be seen that a great deal of ready money is required.

Much judgment and business ability is required in handling a large ship-yard; often a slight modification in a method of securing a small part may result in the saving of thousands of dollars, and naturally only those succeed in ship-building who attend strictly to business.

When the price of the ship has been settled upon and the design elaborated, the latter being, as a rule, left to the builders in the case of merchant-vessels, they being given the number of passengers and amount of freight to be carried, together with the speed and character of service, the preparation for building at once begins.

The lines of the vessel, showing the shape on the outside, are drawn out at full length on a large floor, called the mould loft.

Taking the skeleton of a herring and turning it on its back will give an idea of the construction of a vessel; the ribs are called the frames of the ship, and they come down to the backbone or keel as on the fish. Sections are drawn out to full size, showing the shapes of all the different frames, and wooden moulds are made to these shapes. The iron or steel angles that form the frames are heated in long furnaces and drawn out on a large iron floor, called a bending slab, having a number of small holes in it. Upon this slab the mould to the frame has been previously laid and the shape drawn in chalk, and then a number of pins stuck in the holes along the chalk line. The hot angle bar is then forced against these pins and held by clamps, so attaining the proper shape. While bending it is also bevelled, or one side is so shaped that it will conform with the outside plating coming against it. The angle is then taken in some cases to a scribe board, where the curve of the frame has been drawn out and the shape checked, and any corrections necessary are made by bending the frame coil in a setting machine.

An ordinary frame consists of three parts:

1. What is known as the frame angle bar, extending from the keel to the upper part of the side of the vessel.

2. A floor plate, extending across from bilge to bilge, riveted to the frame at its lower edge.

3. A reverse frame angle, riveted to the upper edge of the floor upon the side opposite to the frame angle, and at the terminations of the floor is carried on up on the frame angle to heights varying with the size and type of vessel.

The holes in the frame angle are punched before bending; those in the reverse angle are marked from the frame angle and punched after bending.

The keel is laid upon blocks extending down to the water's edge, the blocks being high enough to allow the workmen to get under to rivet on the bottom plates. The keel blocks are laid on an incline of about $\frac{1}{4}$ of an inch to the foot. They are spaced about 4 to 5 feet apart and have on each side two sets of standards for supporting the staging upon which the workmen stand.

Keels are of three kinds: The bar keel, side bar keel, and flat plate keel.

The keels are the first part of the vessel laid upon the blocks. In the case of the flat keel the vertical keel plate is next placed, and then the frames are

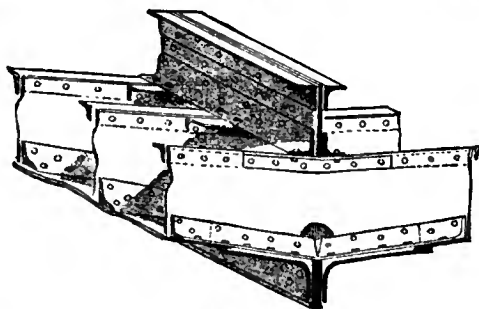

Bar Keel.

raised at points marked upon the keel. The frame, reverse angle, and floor are riveted together on staging about level with the blocks. The complete

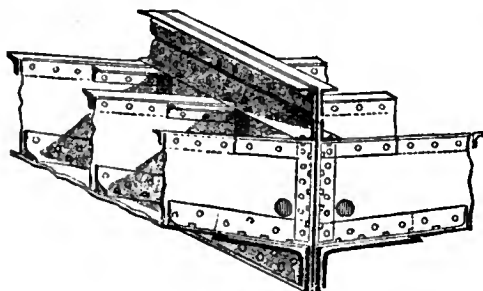

Side Bar Keel

frame is then lifted by means of tackles leading from the ends of uprights, which can be moved along abreast of the position of the frame, and the

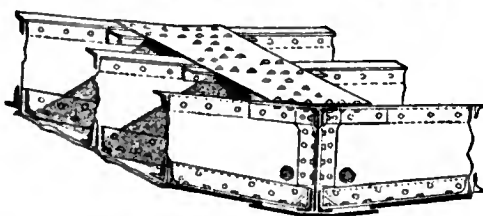

Flat Keel.

frame is bolted in place. Usually one or more beams are bolted to the frames and raised with them, the beams being the cross pieces upon which the decks rest. The stem and stern posts, made of forged iron or cast steel, are raised in place when the framing is well started amidships.

The lines of the edges of the plates forming the outer skin of the ship are marked on the frames, and these spots are faired by long pieces of wood called battens, and wooden templets or skeleton shapes are put up where the plates are to go. Upon these are marked the holes that are to be punched in the plates and the exact sizes of the plates. These are light and easily handled, and are taken down, laid on the plates, and the positions of holes transferred to the plate. The plate is then sheared nearly to size, and is then planed on the butts and the edges of the outer streaks, the holes are punched and counter sunk, so that the rivet may be hammered down flush on the outside. The plates overlap on the edges, the most common system being that known as the raised and sunken system.

The ends butt against one another and are held by butt straps on the inside. When in place and riveted up the edges and butts are carefully calked, and so

made water-tight. In some cases the beams are plated over to form the deck, the deck plank being laid on the plating, but in other cases plates are carried along the sides of the vessel and wood only used on the rest of the deck.

When all the plating is on the outside, and enough of the inside of the vessel completed to give her the requisite stiffness, she is ready for launching. Launches are usually times of enjoyment, and great crowds turn out to see them. While launches are, as a rule, successful, and the ship glides most easily and gracefully into the water, rarely failing to make a bow to the lady who christens her, it must not be forgotten that to transfer a mass of thousands of tons from supports on land to the buoyancy of the water is one of the greatest of engineering feats, and there are few ship-builders who do not heave a sigh of relief when they see their vessel well water-borne.

The vessel rests on the keel blocks, and on each side of the keel blocks is placed a track or ground way, at an inclination of about $\frac{1}{4}$ of an inch to the foot. These extend well out into the water. On top of these are placed the sliding ways, forming a carriage or slide to support the vessel.

The sliding ways are built up to the vessel, and when all is ready for launching wedges are driven in above the sliding ways. In this way the weight is taken on the slidings and the keel blocks are knocked out, and the vessel, held in place by a trip of some sort or a plank bolted to sliding and ground ways, is released and slides into the water. The machinery is then put in, and the vessel completed in every respect. The fittings of vessels are now very elaborate and costly. The drainage system of a large vessel is far more complicated than that of a house, as every one of the numerous compartments must be pumped separately, if necessary. There are water-alarms which tell when a compartment is leaking, and alarms to show when a dangerous temperature has been reached in the coal-bunkers. Provisions are made for exhausting foul air from below and for supplying fresh air.

Payments are made in various ways. In private contracts there are various methods, instalments being paid when certain portions of the work are completed, as when the first frame is raised. Under government contracts the payments are made in ten instalments, with a reservation which, together with the last payment, is kept a certain number of months after the vessel has been turned to the government. A 4000-ton merchant steamer is built in about ten months, while the same size man-of-war will take about two years in building—the former costing about \$300,000 and the latter \$1,200,000.

With a merchant vessel, when everything is completed, a run at full power is usually made for several hours, but with a man-of-war an official trial trip must be made on which a guaranteed horse-power or speed must be attained. As speed is the object to be attained in men-of-war of certain types, it would seem most natural to require a certain speed rather than a certain horse-power, though this is not always done.

In beginning the design of a vessel, it is first necessary to know the conditions of service, the load to be carried, and the speed. It is known approximately what ratio the load will bear to the total displacement in the particular service, and, knowing the total volume of displacement, this volume must be enclosed by a shape which will best attain the given speed and suit the conditions of service and give the required room. When what is known as a model tank is available for experiments, a model is towed at various speeds, and the resistances obtained; and from these the horse-powers required to drive the vessel at various speeds can be computed. From these data the engines are designed. Engines can now be

designed that are very light for the horse-power developed, the engines and boilers of the *Vesuvius* weighing, when the boilers and condenser are full of water, only 250 tons, and developing on this weight 4200 horse-power, giving a speed of 21.65 knots per hour. When a tank is not available for model experiments, the performance of some vessel already built is taken as a basis from which to estimate the required horse-power. The resistance to be overcome is of three kinds: The frictional resistance of the water, which forms the greater part of the resistance at low speeds; the eddy resistance, due to sudden changes of shape or projections; and the wave resistance, which increases most rapidly at high speeds. These are all studied by the naval architect, and every care is taken to keep the bottom clean and well painted to diminish the friction, to get the fairest lines to decrease the eddies, and to choose properly the general dimensions so that the waves raised at the required speed may require the least expenditure of power.

The outlook for the ship-builder in America is excellent. With our large and constantly increasing coasting fleet, wherein the cheap iron ship with economical engines is rapidly becoming a necessity, with excellent rates for freight, and with the wooden vessels fast disappearing, there must be for many years to come a great demand for iron and steel steamers for our coasting trade; and with the uniform cheapening of iron in the United States we shall, in a few years, enter into competition with Great Britain and other European countries in ship-building for the rest of the world.

A bounty bill is to be urged upon Congress providing for the payment, to sail or steam vessels engaged in the foreign trade and built and owned wholly in the United States, of 30 cents per registered ton for each thousand miles sailed, and *pro rata* for any distance less than 1000 miles on any voyage between this and any foreign country or countries. This is excellent, so far as it goes, but our first efforts should be to secure trade, to build up agencies in every large shipping centre where business could be secured for American vessels. Such a method of payment would probably bring about vessels with an exaggerated tonnage measurement and, with economical engines, the voyage would be the main thing and the ports at the greatest distances and with the lowest dues would be visited, and the great object of all—an increased tonnage—would be lost.

A better system, it seems, would be to pay 20 cents per ton of freight carried, and there would then be the decided effort to get freights and trade which are used at home. Great Britain's vast trade enables her merchants to have agents in every port, and Germany, by sending men to offer her goods, is getting control of what little trade we have in Africa. Europe's cheap money is as much to be feared as her cheap labor, and while we are helping the ship-owner we should likewise help the ship-builder, and pay \$5 00 per horse-power on the engines and \$20 per ton weight of hull when of steel and \$10 when of iron.

In the preparation of the above article the following publications have been freely drawn from: *The Shipbuilding Industry of the United States*, by Henry Hall; *Reports of the Secretaries of the Navy*; *Reports of the Chief Constructor of the Navy*; *Reports of the Commissioner of Navigation*.

(L. N.)

SHIRLAW, WALTER, artist, was born in Paisley, Scotland, Aug. 6, 1838, and was brought to the United States in 1840. He worked for a time as a bank-note engraver, but later took up painting, exhibiting first at the National Academy in 1861. In 1868 he was elected an academician of the Chicago Academy, and two years later he went to Munich, where he spent seven years in study. While there he painted the *Toning of the Bell*, and, later on, his best-known

work, Sheep-shearing in the Bavarian Highlands, which received honorable mention at the Paris Exposition of 1878. Among his works notable for breadth of treatment, and often possessing much decorative quality, are: *Good Morning*, owned by the Buffalo Academy; *Very Old, Gossip*, and *Jealousy*, in the New York Academy. He has also executed a large frieze for the house of Darius O. Mills, New York. He was one of the founders of the Society of American Artists, and has been instructor at the Art League, N. Y. In 1888 he was elected to the National Academy. (F. L. W.)

SHIRLEY, WILLIAM (1693-1771), colonial governor of Massachusetts, was born at Preston, Sussex, England, and became a lawyer. His literary proclivity was shown by his tragedy *Electra* and the masque, *The Birth of Hercules*. In 1734 he removed to Boston, where he practised his profession. He was employed as commissioner in settling the boundary between Massachusetts and Rhode Island, when in 1741 he was commissioned as royal governor. He planned the expedition against Cape Breton in 1745, in which Louisburg was captured. He afterward went to England, and was a commissioner at Paris in 1750 to settle the northeastern boundary of New England. He returned to Massachusetts in 1753, and treated with the Indians in Maine. In 1755, when the war with the French was renewed, he was made commander-in-chief of all the British forces in North America. He planned the expedition against Niagara, and led it as far as Oswego, where it was stopped by lack of provisions. His son was killed in Braddock's expedition of the same year. In 1756 Gen. Abercrombie superseded Shirley, who was, however, made lieutenant-general in 1759, and afterward governor in the Bahamas. In 1770 he returned to Massachusetts, where he had built a spacious mansion at Roxbury. There he died, March 24, 1771.

SHOES, as now made, comprise two parts, a sole of thick, solid leather, and an upper of thin and soft leather, often of cloth in ladies' shoes. These parts are fastened together in various ways, usually by sewing or pegging. Until recently the shoe was made outright by a single person, but most of the shoes now made are produced in factories in which there is a well-developed division of labor, a considerable number of workmen being employed on each shoe, while the common use of machinery has replaced much of the old hand-work. No small percentage of the shoes worn in this country are still made in small shops, as custom-work, but even in this branch of the trade labor-saving machinery is employed to a considerable extent. There are more persons employed to-day in the United States in the preparation and the various manufactures of leather than in the manufacture of cotton, linen, and woollen goods, and more than three-fourths of the leather product is used in the making of boots and shoes.

Shoemaking was one of the earliest trades established in the American colonies, and as early as 1648 the shoemakers were legally incorporated as a trade guild. They were most numerous in the town of Lynn, Mass., which has continued to the present day the centre of the American shoe industry. At that time ladies wore mostly stuff shoes, gentlemen boots and shoes made of cowhide, there being few or none made of calfskins till after the Revolution. In 1662 the business of tanning, currying, and shoemaking existed in Virginia, yet as late as 1681 only a few hides were tanned, and most shoes of all grades were imported from England till some time in the 18th century. The legal price of shoes in Virginia at that early date was fixed at 30 or 35 lbs. of tobacco for large sizes. New York also displayed some activity in tanning and shoemaking, but Pennsylvania was more tardy, doing little in this line till

sometime in the 18th century. Toward the middle of the 18th century every new town north of Virginia started its tannery, and shoemaking soon followed; but the bulk of the business continued in New England, while the Southern colonies obtained most of their shoes by purchase.

In 1731 the English parliament, incited by the small demand for shoes from the colonies, ordered the Board of Trade to inquire into the American manufacture, which inquiry resulted in the discovery that the colonists were almost completely supplied with shoes of home manufacture. The family stock of leather was worked up by itinerant shoemakers, who went from house to house, and were followed by itinerant cobblers to repair the worn shoes. In Massachusetts, however, the art was conducted on a larger scale, and considerable exportation of shoes took place to the other colonies and the West Indies. The British effort to lay duties on American imports in 1764 gave a special stimulus to the shoe trade, which continued active till the Revolution. During that struggle for independence the trade was restricted by the great scarcity of hides, and the army suffered greatly for want of shoes. On a requisition from Ticonderoga for shoes to supply over 12,000 men, only 900 pairs could be sent. One-third of the Ticonderoga force was obliged to do duty shoeless in the winter season of 1776. Similar conditions existed in later campaigns. The business revived after the peace, but in 1789 it became necessary to impose a tariff charge to check importations.

As we have already stated, Massachusetts led in the shoe business, and still holds the supremacy. This is particularly the case in the towns near Boston. There are records of shoemaking in Lynn as early as 1635, and in 1650 that town made more shoes than any other in the country. It made a specialty of ladies' shoes, mostly of cloth. By 1750 it had a surplus for export, and sent shoes to New York, Philadelphia, and the South. The business of Lynn largely developed after the Revolutionary war. In 1788 it exported 100,000 pairs; in 1795, 300,000 pairs; and by 1877 its product had increased to 14,000,000 pairs.

The shoes made in the early period were rough, ill-fitting, and imperfect. The workmen were unskilled, and many of the shoes were made by mechanics of other trades, who worked at home at this art in the winter. It was not till 1750 that the knowledge of the art improved. At that period a skilful Welsh shoemaker settled in Massachusetts, who quickly gained a great reputation in the trade by his superior workmanship. The general style of shoes greatly improved under the incitement of his example, and by 1764 Lynn had gained the reputation of making shoes equal to those of London. After the Revolutionary period, other towns came into competition with Lynn for a share of the shoe trade. Haverhill and Danvers early engaged in the manufacture of ladies' shoes, while other towns near Boston successively engaged in the business. Marblehead was one of these, incited thereto by the decline of its fisheries. It now makes about 4,000,000 pairs yearly. The shoes of Lynn are still nearly all women's shoes, the uppers being made principally of lasting or serge, though many are of leather. The work of this town embraces all the light, cheap, machine-sewed styles. Haverhill, which comes next in importance, produces a better quality of shoe, and turns out sewed and pegged work of every kind. Many other places in Massachusetts, Maine, and New Hampshire are extensively engaged in the business, Boston being their commercial centre.

New York is second to Boston as a shoe distributing centre. It has long been famed for the quality of its shoes. Only fine goods are made there, and the city turns out the best factory-made boots and

See Vol. XXI.
p. 830 (p. 839
Am. Rep.).

shoes in the world. Only the finest grades of European calf and kid skins and the best domestic morocco leather are used, with oak-tanned soles. Philadelphia has an equal reputation for the quality of its shoes, while the business has developed in other towns in the interior of Pennsylvania and New York. At present the value of the Massachusetts product is said to be 60 per cent. of that of the entire country, New York about 12, Pennsylvania about 8, and the other States in much lower proportions.

As the shoemaking business increased, workmen began to divide their labor, and each to confine him-



Shoe Pegging Machine.

self to some department, such as crimping, bottoming, heeling, and finishing. Much work was done by associations of journeymen. This system proved advantageous, and has made Boston the principal centre of such operations and the largest shoe market in the world. There have been great improvements in the American manufacture of shoes, due largely to new methods of splitting and currying leather, by which softer and finer material is produced. Remarkable progress has been made in methods of manufacture, the invention of labor-saving machinery greatly increasing the rapidity and cheapness of production. In old times all shoes were hand-sewed. In 1818 the shoe peg was invented by J. W. Hopkinton, of Massachusetts. The

pegs were at first made by hand, afterward by machinery, and at present some 30 establishments are engaged in this branch of the business. There is a shoe-pegging machine in use that is remarkable in its operation, making the pegs and driving them into the shoes at one operation. A shoe can be pegged in ten seconds by this machine. A narrow ribbon of wood, of the thickness of a peg and as wide as the length of a peg, is reeled on a machine to the length of 100 or more feet. One end is pared sharp by the machine. A strong awl worked by the machine pierces holes in the leather, and at the same time a sharp knife splits a peg from the end of the ribbon of wood. The point of the peg is guided to the hole, and as the awl comes out the peg goes in, and is driven home while the awl makes the next hole. The operation goes on with great rapidity, the shoe needing only to be guided and turned. Many other machines are in use, no industry being more benefited in this particular. The sewing-machine was utilized in shoemaking soon after its invention, it being operated by steam, and used in all the large shoe factories. There are other machines for smoothing and rounding the soles after pegging, for last making, and for other departments of the business, the necessary labor on each shoe being much lessened and greatly divided. About 1000 cords of wood are used annually in making shoe pegs, but many of these are exported. One thousand seven hundred pegging machines were in use in the United States in 1873, and where formerly only the coarsest boots and

shoes were pegged, now great quantities of fine pegged work are made. The pegging machine described

was invented in 1851 by A. C. Gallahue, but has been much improved by others. Equally important is the McKay sole sewing-machine, invented about 1858 by L. R. Blake, but perfected and introduced by Gordon McKay. By this machine soles can be sewed on nearly 100 pairs of women's shoes in an hour; 800 pairs in 10 hours is a fair day's work. This machine is in very general use in the United States, and many are used in England and Europe. There are two other sole

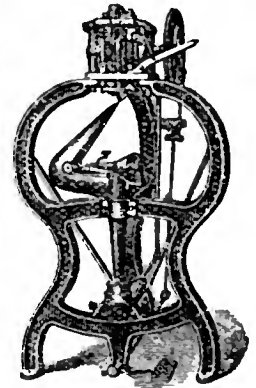

Shoe Sewing-machine.

machine making an almost perfect imitation of handsewed work. There are several machines for stitching, chief among them being the Elias Howe and the Wheeler & Wilson. Other machines in extensive use are the cable screw wire and the wire-tacking machines. There are also machines to set and burnish the edges, to make and trim the heels, and

for various other purposes, while there are scores of minor inventions, all of American production. No other country except, perhaps, England is so well provided with factory-made shoes as the United States. In Europe hand-made shoes are still in the ascendant. The wooden shoes so generally used by the peasantry of Europe are cheap and durable, and, though clumsy, are said to be comfortable. An attempt was made to manufacture them in the United States on a large scale in 1863, but with very little success in sale. A few are now made.

A highly important branch of the shoemaking industry, of 19th century introduction, is the India-rubber shoe, now deemed almost indispensable in cities for wet weather and winter wear. The first

of these were clumsy waterproof shoes imported from Paris, but no shoes of any desirable value were made till after the perfection of the Goodyear vulcanizing process. The India-rubber shoe industry has since then grown to large proportions, and, widespread as are the uses of vulcanized rubber, the shoe and boot manufacture forms one of the largest branches of its employment.

The manufacture of boots and shoes is at present among the most important of those industries carried on at once in large factories and in a vast number of petty shops. The boot and shoe factories re-

small shops sums up to a considerable amount. In 1880 there were 16,013 such shops, employing 22,667 hands, and producing \$30,870,127 worth of boots and shoes. The total product of the country has increased from \$54,000,000 in 1850 to \$196,920,481 in 1880, while to this must be added a production of rubber boots and shoes to the value of \$9,705,724, making the complete annual product of the boot and shoe industry over \$206,660,000. (c. m.)

SHOSHONES, the name of a family of Indians, also known under the name of Snakes, belonging to the California group, and inhabiting a wide range of country, which extends from Idaho into Utah, and from the Rocky Mountains to the Sierra Nevada. As at present known, they are divided into the Shoshones proper and the Utes or Utahs, but seem connected linguistically with the Comanches, the Moquis, and several tribes of California. Their language, indeed, is the type of a family of Indian languages which seems at one time to have been widely extended. When first seen, by Lewis and Clark, in 1805, they were west of the Rocky Mountains, but had traditions pointing to the east and south as an earlier habitat, they having apparently been driven over the mountains by hostile tribes.

The Shoshones proper include the Bannacks (though some class this as a separate tribe) and several independent bands which bear special names. Most important of these are the Koolsati-Kara or Buffalo Eaters, of Wind river; the Tookarika, Mountain Sheep Eaters, of Salmon and Snake rivers; and the Shoshonee, White Knives or Diggers, of the Great Salt Lake basin. Some of these bands are fierce and warlike, others mild and inoffensive. They became hostile to the whites about 1849, and continued so, at intervals, till 1863, some of the bands suffering severely in consequence. The Diggers of Salt Lake were nearly exterminated by California volunteers in 1862. Peace was made with most of the bands in 1863, and with others in 1864 and 1865, but the government failed to properly observe its treaty stipulations, and many of the bands resumed hostilities. In 1867 Gen. Steele conducted a campaign against the Shoshones, killing a number of them and destroying their large stores of provisions. Since that date they have been peaceful.

The government set aside reservations on which it sought to gather the scattered bands of the tribe, there being three of these reservations, the Fort Hall, established in Idaho in 1867 for the Bannacks, and several bands of the Shoshones; the Shoshone, established in Wyoming in 1868; and the Lemlie agency in Idaho. The first contains about 1530, the second something over 870, and the third has about 600 Indians. In addition, there are Shoshones in Nevada and Utah estimated at 1000, and a band of 400 in northwest Idaho.

The Shoshones of the several bands differ widely in character of food and modes of life. Most of those of the south live on roots and small animals. In the north they live largely on the fish of Shoshone river, and on large game taken by hunting, in which they are skilful. They are fond of barter and personal adornment, and of games of chance, dress in buffalo and deer skins, and live in skin tents. Among their customs is that of burning or burying with the dead his property, the wife or horse being formerly killed over the corpse. On the reservation Episcopalians, Catholics, and other denominations are making efforts to convert and educate these

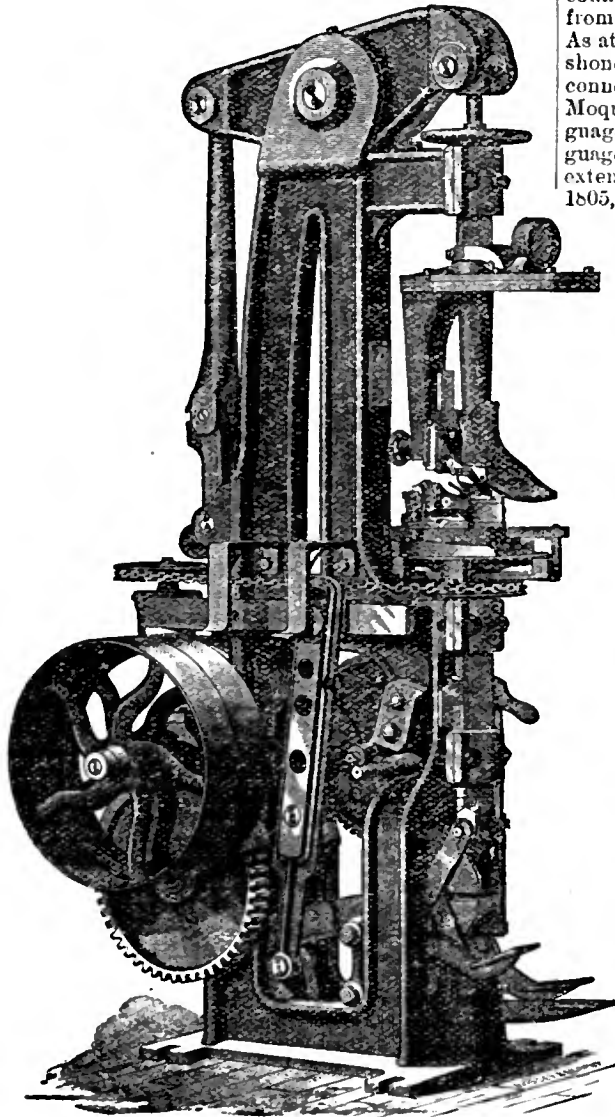

Heeling and Trimming Machine.

ported in the census of 1880 numbered 1959, with a product valued at \$166,050,354. The material consumed included 6,831,661 sides of sole leather, 21,147,656 sides of upper leather, and 32,960,614 pounds of other leather, with a total product of 30,590,896 pairs of boots, and 94,887,615 pairs of shoes. Of the factories, Massachusetts has more than half, 932, with a total product of \$95,900,510; New York, a product of \$18,979,259; Pennsylvania, New Hampshire, and Maine, each over \$5,000,000; the remaining product being divided among many States.

In addition to the factory production, that of the

Indians, and are meeting with some success. Vocabularies have been made from the speech of various bands, but no critical study of the Shoshone languages has yet been made.

SHUBRICK, WILLIAM BRANFORD (1790-1874), rear-admiral, was born at Charleston, S. C., Oct. 31, 1790. His father, Col. Thomas Shubrick (1755-1810) had served aside to Gen. Greene and Lincoln. William, with his elder brother, John Taylor Shubrick (1788-1815), left Harvard College to enter the navy in 1806. They served on the Constitution under Stewart and took part in several noted exploits. John was lost at sea while bearing to the United States the treaty concluded with Algiers in 1815. William had the command of a squadron in the West Indies in 1838, and in the Pacific in 1847, at which time he captured Mazatlan and assisted in establishing U. S. authority in California. In 1858 he had command of the Brazilian squadron, and in 1859 conducted the expedition against Paraguay. In 1862 he was retired with the rank of rear-admiral. He died at Washington, May 27, 1874. His brothers, Edward Rutledge Shubrick (1794-1844) and Irvine Shubrick (1797-1849), were also naval officers. The former attained the rank of captain, and had command of the Brazilian squadron when he died, March 12, 1844. The latter had served under Decatur and was captured with him in the President in 1815. He became commodore in 1841, and died at Philadelphia, April 5, 1849.

SHUFELDT, ROBERT WILSON, naval officer, was born at Red Hook, Dutchess Co., N. Y., Feb. 21, 1822. Entering the navy as a midshipman, May 11, 1839, he had risen to the rank of commander in 1853, but in 1854 he resigned from the navy and was for several years in responsible positions in the mercantile service. He was for two years chief officer on the Collins line of Liverpool steam-ships, and thereafter in command of steamers plying between New York and New Orleans. When the civil war broke out he was commander of the steamer Quaker City on the New York and Havana line, and during the first year of the rebellion was U. S. consul-general for Cuba, a situation of high importance, which he filled with eminent tact and ability. He resigned this office in 1864 and was appointed commander, his commission dating back to November, 1862. In the blockade of Charleston he commanded the steam-ship Conemaugh, and took part in the engagements on Morris Island. In 1864 he was in the Gulf blockading squadron. In 1865-66 he commanded the flag-ship of the East India fleet, and that of the Mediterranean from 1871 to 1873. From 1875 to 1878 he was chief of the bureau of equipment and recruiting, and was commissioned commodore in 1876. In 1879-80 he sailed on a special mission to Africa and the East Indies to report on the best means of reviving American trade with these countries. In 1883 he was advanced to rear-admiral, and retired from the service, Feb. 21, 1884. While he was on the African expedition he was presented with a sword by Said Burgash, Sultan of Zanzibar.

SIAM. See INDIA.

SIBLEY, HENRY HASTINGS, pioneer, was born at Detroit, Mich., Feb. 20, 1811, his father being a judge of the Supreme Court of Michigan. He received a classical education, and for a time studied law. This, however, he abandoned for mercantile pursuits, becoming first a servant and subsequently a partner of the American Fur Company, having its stations at Mackinaw and Fort Snelling. His employment led him to make frequent excursions into the unexplored regions of the Northwest, in one of which he reached the mouth of the Minnesota river. He was so charmed with the country that he fixed his home at Mendota, there erecting for

himself the first stone house within the bounds of what has since become the State of Minnesota. Most of his time here was devoted to frontier sports. In November, 1848, he was chosen a delegate to Congress to represent a district cut off from Wisconsin when it was admitted into the Union and had its boundaries fixed. Here he secured the passage of a measure constituting this district, along with a vast additional tract west of the Mississippi, into the Territory of Minnesota, and from this he was elected congressional delegate in 1849 and 1851. In March, 1858, it was admitted into the Union as a State, and he was chosen its first governor. When the Sioux made their great rising, in 1862, he raised and commanded a white volunteer force which, at the decisive battle of Wood Lake (Sept. 23, 1862), broke the power of the hostile savages. For his skill and gallantry here he was made brigadier-general of volunteers, and was afterward brevetted major-general. During Pres. Grant's administration he was appointed a member of the board of Indian commissioners, and in 1871 was chosen to the legislature, where he vigorously resisted repudiation of the State railroad bonds, and was thus instrumental in restoring the credit of his State. In 1888 Princeton College created him LL. D. Gen. Sibley is president of the chamber of commerce of St. Paul, Minn., of the board of regents of the State university, and of the State historical society.

SIBLEY, HENRY HOPKINS (1816-1886), general, was born, May 25, 1816, at Natchitoches, La. He graduated at West Point in 1838, and was appointed 2d lieutenant of the Second Dragoons, serving in the Florida war. Promoted 1st lieutenant in 1840, he served in the Everglades expedition against the Seminoles, and acted as adjutant of his regiment from 1841 to 1846. In 1847 he was made captain, and served in the Mexican war, taking part in the siege of Vera Cruz, in the battles of Cerro Gordo, Contreras, Churubusco, Molino del Rey, and the capture of the City of Mexico, and gaining the brevet of major. For several years he served on the Texas frontier against the Indians, and afterward in Kansas, during the Free Soil conflict, and in the Utah expedition, and the Navajo expedition of 1860. On the outbreak of the civil war he was in New Mexico, where he was promoted major, May 16, 1861, but the same day resigned his commission to enter the Confederate service, in which he was made brigadier-general. Being unable to shake the allegiance of his troops, he raised a brigade of nearly 2500 men in southwest Texas, and at its head left Fort Bliss, January, 1862, to effect the conquest of New Mexico, appearing before Fort Craig on Feb. 16. On the 21st he fought the action of Valverde with Col. E. R. S. Canby, commander of the fort, which resulted in the withdrawal of the Union troops within its shelter. In March he occupied Albuquerque and Santa Fé, but in April he was compelled to evacuate these places and leave the territory for Fort Bliss. After this he commanded his brigade under Gen. Richard Taylor and E. Kirby Smith. At the close of the war he entered the service of the Khedive of Egypt and took part in the construction of coast and river defences. After a stay of 5 years he returned, broken in health, to the United States, and supported himself by lecturing on Egypt. He died at Fredericksburg, Va., Aug. 23, 1886. Gen. Sibley was the inventor of the tent known by his name and, while in the U. S. service, received letters patent for it, but forfeited his rights by his disloyalty. After his death, a claim for compensation was brought before Congress by friends of his family, but it was rejected in February, 1889, and his widow, who is said to have always manifested loyalty to the Union, expired on receiving the news.

SICKLES, DANIEL EDGAR, general, was born in New York City, 1823. He attended the university there, but left it to learn the printer's trade. After pursuing this for some years, he studied law, and in 1841 began practice in his native city. In 1847 he entered the Legislature and became a leader of the Democrats, and in 1853 accompanied James Buchanan to London as secretary of legation. On his return, in 1855, he was elected to the State senate, and next year, to Congress, where he served two terms. In 1859, discovering a guilty connection between his wife and P. B. Key, U. S. attorney for the District of Columbia, he shot the latter dead on the street in Washington, Feb. 27, 1859, for which he was tried for murder, but, after a trial of twenty days, acquitted. On the outbreak of the civil war he raised in New York City the Excelsior brigade, of five regiments, of one of which he was commissioned colonel, and in September he was made brigadier-general of volunteers, in which capacity he served under General Joseph Hooker, distinguishing himself at Williamsburg, Fair Oaks, and Malvern Hill. His brigade served also in the Maryland campaign, and bore a conspicuous part at Antietam. He was appointed to succeed General Hooker in command of the division, and fought bravely at Fredericksburg. When the Army of the Potomac was reorganized, in 1863, he was appointed major-general and assigned to the command of the Third corps, distinguishing himself again at Chancellorsville. His command fought desperately at Gettysburg in defence of its position between Cemetery Hill and Little Round Top, but was forced to yield to superior numbers, and here General Sickles lost a leg. Nevertheless, he continued in active service till early in 1865, when he was sent on a mission to Colombia. In 1866 he joined the regular army as colonel and next year was brevetted brigadier-general for gallantry at Fredericksburg, and major-general for meritorious conduct at Gettysburg. In 1865-67 he commanded the military district of the Carolinas, where he carried out the work of reconstruction with such vigor that Pres. Johnson relieved him of his command. In April, 1869, he was placed on the retired list of the U. S. Army with the full rank of major-general. In May of the same year he was appointed minister to Spain, which post he resigned in 1873, when he resumed his residence in New York City. There he holds the positions of president of the State board of civil service commissioners, and of the board for the erection of New York monuments at Gettysburg.

SIDGWICK, HENRY, an English philosopher, was born at Skipton, Yorkshire, in 1838. He was educated at Rugby and at Trinity College, Cambridge. He was fellow of the latter from 1859 to 1869, and in 1881 was elected an honorary fellow of the same. He was lecturer at this college from 1859 to 1875, and was then appointed prælector of moral and political philosophy. He has been prominently connected with the promotion of higher education of women at Cambridge, and especially in the foundation and management of Newnham College. He has contributed to the *ENCYCLOPEDIA BRITANNICA*, and to various reviews on philosophical subjects. He has published *The Methods of Ethics*, *Principles of Political Economy*.

SIEMENS, ERNST WERNER, a German electrician, was born at Lenth, near Hanover, December 13, 1816. He entered the gymnasium of Lubeck, and afterward the School of Artillery and Engineering of Berlin, becoming an artillery officer in the Prussian army in 1838. He afterward engaged ardently in the study of chemistry and electro-metallurgy, and in 1841 took out a patent for electro-plating and gilding. In 1844 he was placed in charge of the government artillery works at Berlin. He also de-

voted himself to the perfecting of electro-telegraphy, and in 1848 laid at Kiel the first wires for the explosion of submarine mines by electricity. In 1849 he left the army, and formed in Berlin the telegraph-building establishment of Siemens & Halske. This establishment has built the principal telegraph lines of Russia, Spain, Brazil, North Germany, and elsewhere. Siemens has been an active inventor, and has greatly advanced the science of telegraphy by his achievements in this direction. Among the most important of his inventions are a method of determining the position of injuries in subterranean and submarine cables, a method of examining insulated wires, and a method of charging underground and submarine cables by which the disturbing effects of induction may be reduced. In addition to these he has taken part with his brother, Sir Charles William Siemens (for whom see the *ENCYCLOPEDIA BRITANNICA*) in many of his important inventions, among them an improved steam-governor, an air-pump, a water-meter, a regenerative steam-engine, and a regenerative gas-furnace, the latter being an invention of the utmost value in metallurgy. He also joined with his brother in building the Indo-European telegraph in 1868-69.

SIEMERING, RUDOLF, German sculptor, was born at Königsberg in 1835, and was educated at the academy there. Removing to the neighborhood of Berlin, he became a competitor in designs for monuments to Schiller and to Goethe. Though unsuccessful, his designs drew attention to his merits. He completed a memorial of Albert the Great, and, later, a sitting figure of King William I. for the Berlin Exchange. The statue of Germany which was erected at Berlin to commemorate the mastering of troops there received some touches from his hand. His greatest work is the Luther-Memorial, which was unveiled on the 400th anniversary of the Reformer's birth, Nov. 10, 1883, at Eisleben. The statue represents Luther in the act of burning the Pope's bull. Four bronze reliefs exhibit other incidents from the life of the Reformer. In 1877 Siemering had erected at Marienburg a statue of Frederick the Great. He has also undertaken a memorial for the siege of Leipsic. His works are noted for their realistic truth. He especially excels in relief work.

SIGEL, FRANZ, a general of the American civil war, was born at Sinsheim, Baden, Nov. 18, 1824. He graduated at the military school of Karlsruhe, and served as an officer in the army of the Grand Duke of Baden, attaining the rank of adjutant in 1847. When the revolutionary movement of 1848 broke out, he resigned from the army and joined the insurgent forces, being appointed minister of war by the revolutionary authorities on June 1, 1848. He took part in the unsuccessful campaign against the Prussians, and after the defeat of Miroslawski Sigel skilfully led back the beaten and dispirited force and placed it safely in the fortress of Rastadt. On the dissolution of the provisional government he withdrew to Switzerland, but was not permitted to remain there by the Swiss government, and sailed for the United States, reaching New York in 1850. Here he taught mathematics for some years in the academy of Dr. Rudolph Dulon, whose daughter he afterward married, interested himself in military matters, and became major of the Fifth regiment, N. Y. militia. In 1858 he removed to St. Louis, became a teacher in the college of that city, and on the outbreak of the civil war received a commission as colonel of the Third Missouri volunteers, stationed at Camp Jackson.

The campaign in Missouri began with the active movements of General Lyon, who broke up the camp at Jackson, took possession of the United States arsenal at St. Louis, and defeated Colonel

Marmaduke at Booneville, thus checkmating the governor, who was planning to carry the State out of the Union. Sigel was sent on June 23d to southwest Missouri, where Price had collected a strong body of Confederate militia, and on July 5th met the enemy at Carthage, his 1200 men being opposed to 5000. A severe conflict ensued, ending in his repulse, but he conducted the retreat so skilfully as to check pursuit and inflict heavy loss upon the enemy. This repulse rendered it necessary for Lyon to take some decisive action, or to abandon that portion of the State. He preferred the former course and advanced rapidly to Sigel's support with about 5000 men, meeting the enemy, with more than twice that number, at Wilson's Creek on August 10th. In the engagement that followed Lyon was killed, and Sigel (now acting-general), who had been sent to gain the enemy's rear, met with a disastrous repulse. He conducted the retreat from Springfield, the Confederates having been too severely punished to make any vigorous pursuit. He now received a commission as brigadier-general, to date from May 17th. No further engagement of importance took place in Missouri, but the armies on both sides increased in numbers, and General Price, in command of the Confederate forces, was eventually obliged to retreat to Arkansas, whither he was followed, in February, 1862, by General Curtis with a Union army. On March 7th the armies met at Pea Ridge, the Confederates then under Van Dorn, and a severe battle followed, Van Dorn attacking with great energy before the Union lines had completed their formation. Curtis, however, held his ground, and gradually brought his men into position, Sigel, with the left wing, not reaching his designated ground until late in the night. The battle was renewed the next morning, and the victory was due to Sigel's skilful manœuvres. He pushed forward his line by alternate movements of batteries and infantry supports, pressing back the enemy's right until the Union lines formed a curve enclosing the enemy, when by a heavy concentrated artillery fire the latter were forced to retreat, and were finally completely routed. In this engagement the Union force was under 10,000; the Confederate, perhaps twice as strong. This was the last engagement of importance in that section of the Union.

Sigel's energy, skill, and success had now brought him into high repute with the German element of the population, and when in May, 1862, he resigned his position in consequence of unpleasant relations with General Halleck, the authorities at Washington showed their recognition of the value of his services by appointing him major-general, to date from March 21st. On June 2d he was placed in charge at Harper's Ferry, and on the 26th succeeded to the command of Fremont's army corps. He took part in the second battle of Bull Run, Aug. 29-30, 1862, and on Sept. 14 was made commander of the Eleventh army corps. In March, 1864, Sigel was placed in command of the department of West Virginia, and on Grant's advance against Lee he took part in the several co-operative movements ordered by the commanding general. His duty was to advance with the 10,000 men under his command, march up the Shenandoah Valley, and threaten the railroad communication with Richmond. In the accomplishment of this movement he was met by the Confederate General Breckenridge at New Market, on May 15th. Breckenridge made an impetuous charge upon Sigel's columns, and a sharp fight ensued, which ended in the Union forces breaking and flying in disorder up the valley, the Confederates pursuing and inflicting severe loss in men and materials during the 30 miles retreat. This ended Sigel's military career. He was immediately relieved of his command, and succeeded by General Hunter.

Since the war Sigel has resided in New York City, taking some interest in politics. In 1871, he was elected register of the city of New York. In 1886 he was appointed a pension agent.

SIGNAL SERVICE. Before the American Civil War General A. J. Myer, at that time a surgeon in the army, had already conceived a simple plan of communicating by signals between the soldiers and distant stations when the electric telegraph was not available. His plan was a modification of the Morse alphabet, and in place of dots and dashes he used a flag held in the hand of the signal-man, who, by waving it to the right for a dot and to the left for a dash, was thus enabled to spell out the letters of any word by signals that could easily be seen from one to twenty miles away, according to the clearness of the sky and the location of the observers. At night-time the waving of a lantern answered the same purpose; in fact, on special occasions, any signal whatever, such as a tap, an ejaculation, a wink given singly or doubly, and arranged in groups according to some previously concerted plan, afforded the means for distant communication. This simple idea, which was at first designed for immediate use between military parties scattered on the plains of the West and Southwest, found important application during the war which soon after broke out.

On the 21st of June, 1860, the Act making appropriations for the support of the army added to the staff of the army one signal officer, with the rank of major of cavalry. Subsequently, in recognition of the great services rendered by General Myer, the Act of June 30, 1864, gave him the title of Chief Signal Officer of the Army, with the rank of colonel, which rank was subsequently raised to brigadier-general (June 16, 1880), at which it still remains. During the war the important services of the many officers and men engaged under General Myer were freely acknowledged. At the close of the war, however, his staff was cut down to a small number, barely sufficient to maintain a school of instruction at what was then called Fort Whipple, now Fort Myer, on the Arlington estate near Washington, D. C. In the subsequent development of the work of the military signal office, General Myer properly and successfully maintained that the working of the electric telegraph for military purposes, the use of balloons and pigeons, and all other methods of communication at a distance were the proper work of his corps. The methods of building rapidly telegraph lines on the Western plains were so modified as to apply to the hilly and mountainous regions of the country, and when it became necessary to build such lines along the sandy sea-shore over the greater part of the distance from Boston to Key West, connecting together life-saving, lighthouse, and meteorological stations, the wooden pole was successfully replaced by iron tubes with a broad flange, which latter buried itself in the sand, forming a base for the whole. The field telegraph train, ready at a moment's notice to build ten miles of telegraph line, was the characteristic rallying point of the telegraph corps, as the kit of flags and torches was the emblem of the signal corps in general.

General Myer has often told the present writer of his various schemes for developing the further usefulness of the signal corps in times of peace as well as of war. Thus, at the time of the extensive riots of 1877, he kept the President informed by regular three hour reports of the state of the country at each of the 150 signal-stations. As his code and methods applied to the ocean as well as the land, he recommended its introduction into the Navy, and contributed greatly to the general introduction of the International Code. But his greatest triumph consisted in the utilization of the signal corps for the transmission of weather-reports to the

central office, and the dissemination thence of weather-predictions and signals that gave public warning of storms and daily weather-changes; it is this work that has made the Signal Service widely known throughout the civilized world. The importance and possibility of weather-predictions by means of the telegraph had been foreseen from the very first success of Prof. Morse on the line between Washington and Baltimore in May, 1854; reports had been collected and maps sent out daily by Prof. Henry at the Smithsonian Institution in 1854. European governments had then taken up the work and issued storm-warnings in Holland, France, and England. After peace had been restored in the United States Prof. C. Abbé, during 1853-63, had organized a system of reports and predictions for the benefit of the Cincinnati Chamber of Commerce, and, based upon his success, in the latter year Prof. Lapham, of Milwaukee, had caused memorials for a general national system to be endorsed by all Chambers of Commerce and Boards of Trade, which were then presented to Congress with a proposed bill by General H. E. Paine. As soon as the matter had been referred to the proper committee, General Myer appeared before it and explained convincingly the appropriateness of putting the work of weather-predictions and storm-signals in the hands of the Signal Service, which was officially done in February, 1870. The first bulletin of observations was issued by telegraph, Nov. 8, 1870, and occasional predictions were afterward made, it is said, by Prof. Lapham and General Myer, but systematic tri-daily weather-predictions began to be made by the present writer, February 12, 1871, and have continued unbroken from that day forward, excepting only that on July 1, 1888, reports and predictions began to be made twice instead of thrice daily. The scope of the work and duties of the Signal Service was at first confined to storms and floods, but has been successively extended to cover every important feature of the weather that can affect human industry, and it would be belittling its work to say, as has been said, that the agricultural interests receive the greatest benefits from it. Neither is its usefulness confined to the United States, since it exchanges reports by telegraph with Canada and the West Indies, and by mail with every civilized nation. The service has not merely a practical financial field of usefulness, but has also done good service in educating the people to a truer appreciation of science and the laws of nature. It has had to combat with the prejudices of the ignorant, who cling to the predictions of almanacs, astrologers, sun-spot men, and sensationalists like Wiggins; there is every evidence that at the present time the people look to the weather-signals, the weather-predictions, the weather-maps, the clouds, and the barometer, when they wish to foresee the weather, and have rid themselves of most of the superstitious that were formerly in vogue among the ignorant. Probably the most important feature of the service has been the remarkable promptness and rapidity with which it lays before the public its reports and predictions. A series of observations is made, for instance, as formerly, at 11.00 or 11.35 P.M., Washington time, simultaneously throughout the country; all necessary telegraph wires are put at the disposition of the service for 20 or 30 minutes until these observations are collected at Washington, they having meantime been also "dropped" at numerous other stations on their way. Being translated and put upon a map as soon as received, this work is finished before midnight, and before 1 A.M. all predictions, signals, and other orders have issued to the observers and to the Associated Press. By daylight of the next morning the public everywhere has received the morning paper with the predictions, or noted the storm-signals flying, or the cold-wave

signals displayed. In general, two hours, or two and a half suffice for the whole work of observing, predicting, and disseminating. Besides the tri-daily map, General Myer instituted the weekly weather-chronicle, the monthly weather-review, the tri-daily bulletin of observations, and the international bulletin of simultaneous observations taken throughout the world, accompanied by a daily map of the weather over the entire northern hemisphere, on the land and sea. After his death, August 24, 1880, a short interregnum occurred during which Adjutant-General R. J. Drum was acting chief, and Brigadier-General W. B. Hazen was then appointed Chief Signal Officer. During the latter's administration much attention was given to the enlistment of a better class of observers; to the introduction of civilian scientific experts; to the improvement of instruments and of their exposures; to the general inspection of the stations; to the observation of atmospheric electricity; co-operation in international polar meteorological research; to the introduction of uniform standard time; instruction in meteorology; the regulation of the finances of the service; the utilization of the homing-pigeon for military purposes; the initiation of cold wave signals, and of weather crop-bulletins.

During General Hazen's sickness, and after his death, January 16, 1887, General A. W. Greely, who had returned from his Arctic expedition, was temporarily in charge, and on March 3, 1887, was confirmed as Chief Signal Officer. His administration has thus far been signalized by remarkable energy in reducing unnecessary expenses, by his advocacy of at least a partial civilian organization under civil service rules, and by the securing of a new, convenient, and commodious building for the office in Washington in place of the disreputable, inconvenient houses hitherto rented for that purpose.

Notwithstanding the general success of the Weather Bureau as conducted by the Chief Signal Officer, there has been a long struggle over the question as to whether it would not be more appropriate as a civilian rather than a military organization: the general argument being that the young men who have enlisted as privates in the signal corps, expecting to devote themselves therein to meteorology, have been intellectually and socially too far above those ordinarily enlisting as privates in the army to justify holding them at the same rank; and again, that the work done is a practical and beneficent application of science, such that men who have devoted themselves to the study of science should be brought into the signal service more freely than is practicable so long as the strictly military organization is maintained. As the outcome of this long agitation of the subject the sundry civil appropriation bill, signed by Pres. Cleveland, Oct. 4, 1888, enacted that a very large proportion of those who have hitherto been carried on the rolls as privates and sergeants shall receive civilian appointments, a change which has immediately resulted in infusing a new spirit of ambition among those who have for so many years given their days and nights to the work of a service that is really an applied science, and not necessarily of a military nature. A further step is still urged by many members of Congress by which the Signal Office will remain as formerly a military branch of the army, while the Weather Bureau will become a bureau of the proposed Department of Industry, Commerce, and Agriculture.

(c. a.)

SIGOURNEY, LYDIA HUNTLEY (1791-1865), was a poet whose writings, by their religious tone and domestic sentiment, obtained an extensive but fleeting popularity. She was the daughter of Ezekiel Huntley, a veteran of the Revolution, and was born at Norwich, Conn., Sept. 1, 1791. She was well educated, and at the age of nineteen began to teach. In

1814 she removed to Hartford, where she conducted a school for young ladies. In 1819 she was married to Mr. Charles Sigourney, a merchant of Hartford. From her early contributions to periodicals her first volume, *Moral Pieces in Prose and Verse* (1815), was collected. More ambitious were her poems, *Traits of the Aborigines* (1822); *Zinzendorf* (1836); *Pocahontas* (1841), which showed an earnest effort to present the poetical aspects of American scenery and history. *Pleasant Memories of Pleasant Lands* (1842) was the record of a tour in Europe, during which some of her poems were published in London. In 1848 a collected edition was issued in New York, with illustrations by Darley. Altogether, as shown by her *Letters of Life* (1866), she wrote fifty-six books, some of which were intended for children, and several were biographical. She died at Hartford, June 19, 1865.

SILK. This article is confined to silk culture and manufacture in America. The effort to produce silk in America began very early in the history of the country. Cortez, the conqueror of Mexico, had eggs of the silk-worm brought to that country in 1531; he had previously planted mulberry-trees, to furnish food for the worms. The experiment was successful. Silk was produced, woven, and sent abroad. The industry, however, did not long flourish, and had almost vanished by the end of the century. Silk-worms were sent to the English colonies in 1619. James I. had been foiled in his efforts to establish the rearing of silk-worms in England, and sent eggs to Virginia, with an expert in their culture. He earnestly urged that silk should be produced instead of tobacco, against which he issued his famous *Counterblast*; bounties were offered to farmers who should produce silk, and penalties laid on those who should fail to plant mulberry-trees. The experiment at first promised well, but was soon neglected in favor of tobacco-raising. Some little silk was sent to England, but before the end of the century the industry died out in Virginia. The French Huguenots of the Carolinas were the first to introduce the silk manufacture into this country. They made silk-mixed goods, importing the raw silk for that purpose. Some silk was produced in the Carolinas, but no important quantity. John Law sought to introduce silk culture into Louisiana, as a part of his vast scheme for the improvement of that country, but the effort was unsuccessful. In 1732 the culture of the silk-worm was introduced into Georgia, and with more success than elsewhere in the country, under the stimulus of vigorous encouragement from England. In 1735 Oglethorpe took 8 lbs. of silk to England, which was woven into a dress for Queen Caroline. In 1750 a filature, or reeling establishment, was founded in Savannah. The exportations of raw silk grew until 1772, averaging 500 lbs. yearly, though rarely over 1,000 lbs. in any one year. In 1766 the culture reached its highest point, 20,000 lbs. of cocoons being produced, these yielding something less than 2,000 lbs. of raw silk. During the Revolution the product was made into sewing silk, and sold at home. The industry vanished soon after the war.

Silk culture began early in Pennsylvania, and silk was sent to England in 1726. It seems to have been somewhat active in Connecticut in 1732, and there is evidence that silk was woven there to some extent. The first coat and stockings manufactured from New England silk were worn by Governor Law in 1747, and the first silk dress by his daughter, in 1750. Efforts at manufacture were made elsewhere. In 1765 it was stated that within four days 100 silk-throwers had left England for New York and Philadelphia, with the purpose of establishing silk manufacture in those cities. Dr. Franklin wrote a

letter in 1770 strongly encouraging the silk-worm culture, and the planting of the mulberry. Silk manufacture in Connecticut became active after 1760, and for many years was carried on there more extensively than anywhere else in the United States. During the colonial period, and for many years after the Revolution, the manufacture was chiefly of sewing silk, and was largely a household art. The methods of reeling and twisting were very primitive, and much of the silk became tangled and wasted. In 1790 the manufacture of silk laces began at Ipswich, Mass., where it continued many years. Silk shoes are said to have been made. The making of fringes, coach laces, and tassels began at Philadelphia in 1793, and in 1815 silk trimmings were made in that city by William H. Horstmann. The manufacture of sewing silk by steam-power began in 1810. About 1825 the interest in the silk industry greatly increased. There was at that time a large importation of silk goods, and Peter S. Duponceau (*q. v.*), president of the American Philosophical Society, brought the subject of the encouragement of American silk manufacture to the attention of Congress, established a small filature in Philadelphia, and exerted himself somewhat successfully for the advancement of the industry. Silk societies were established in several States, books on silk culture published, new machinery for silk manufacture invented, and a general interest in the subject awakened.

This interest led to an extraordinary development of speculation, which ended in checking the American silk industry for years. The worms had, up to this time, been fed on the leaves of the white mulberry (*Morus alba*), and some other plants. After 1830 a vigorous effort was made to introduce the Chinese mulberry (*Morus multicaulis*), on the ground of its rapid growth and abundant production of leaves. It was objected that it was not hardy, and not relished by the silk-worms like the white mulberry, yet a fever of speculation broke out, and the price of the tree went up rapidly, until cuttings reached an extravagant price. The excitement reached its height in 1839. People grew wild in their hopes of riches from the new tree, slender cuttings of 2 feet in length sold at from \$2 to \$5 each, and one nurseryman ordered 5,000,000 young trees from France, sending over \$80,000 as advance payment. In the autumn of 1839 the bubble burst. Thousands of the speculators were ruined. By the spring of 1840 trees could not be sold for 2 or 3 cents each. In 1844 most of those that remained were destroyed by a violent storm, and the white mulberries were widely blighted. Thus ended one of the most extraordinary outbursts of speculation in America.

Meanwhile the manufacture of silk goods was growing. Raw silk began to be imported from China, Turkey, and Italy in considerable quantities, improved machinery was invented, and by 1850 several firms had built up a good business in the manufacture of sewing silk and twist, some dress trimmings, and a few ribbons. From 1850 to 1860 the demand for sewing silk and twist increased, and it was found that the best American surpassed the best Italian in quality, evenness, strength, and color. The production of the machine twist in 1852 gave a great impetus to the sewing-silk industry, which has so advanced since that date as to free itself from foreign rivalry. The manufacture of woven silk goods now revived, and soon became of importance. About 1855 the manufacture of spun silk (now including almost every kind of silk goods) began at South Manchester, Vt. Silk ribbons began to be made in 1861. The industry was much stimulated during the war by the protective duty on manufactured silk and the free entry of raw silk. Paterson, N. J., "the Lyons of America," had 40 or 50 silk factories,

and others started in many places. Plain gros-grain dress silks were made by 1866, and brocaded silks and satins were attempted on a large scale even earlier. The manufacture of silk laces was established at Brooklyn in 1871. That of handkerchiefs was of slow growth till 1876, when it received a remarkable impetus from the Centennial Exposition, which indeed aided the silk industry generally. The manufacture of various other kinds of silk goods was attempted; silk trimmings became a very large branch of the industry, while silk tapestry and velvets were introduced as new branches of manufacture. A great advance was made in the production of dress silks of every color and variety, the American goods of this kind surpassing French goods of the same grade, and selling at lower prices. In 1874 the silk goods manufactured in the United States were valued at \$16,269,157. By 1880 they had increased to \$34,519,723. There has been a steady increase since.

The production of raw silk in this country by no means kept pace with this progress. Since the *Morus multicaulis* excitement the silk product has not been an observable element in the manufacture. Silk culture began in California in 1854, and gradually grew until it became a mania, but has died away again and is now almost extinct. In the census year 1880, the amount of silk produced in the United States was too small and scattered to be estimated, while the importations of raw silk reached 2,562,236 lbs. The Woman's Silk Culture Association of Philadelphia was founded during the Centennial Exposition, and has made active efforts to arouse interest in the industry, but as yet with slight success. Other associations are the Kansas State Silk Station at Peabody, and the State Board of Silk Culture at San Francisco, each of which is endeavoring to awaken interest in the industry at their respective localities. It has also been actively taken up by the Agricultural Department at Washington, where a filature for the reeling of silk from American cocoons was established in 1886. Cocoons were purchased from the three associations above named, but so far the cost of the experiment has been greater than the value of the product. It is continued, however, with the hope of more success. Eggs of the large Milanese variety of silk-worm are being distributed by the department, from which good results have been obtained. The history of silk production in America, however, is not one to encourage any extravagant hopes in that direction, the industry never having proved sufficiently profitable to largely enlist American interest. (C. M.)

SILO. See ENSILAGE.

SILVER, a precious metal which, more than any other, is found in combination with different substances, as sulphurets, oxides, and other metals. It occurs in several geological formations, widely separated in age and locality, and is therefore very generally diffused. Of mineral ores experiment has proved that only one in seventeen is free from silver, while minute traces of it exist in sea-water and in organic substances. Gold never occurs in nature unassociated with silver, and the latter is said to be never wholly free from gold. It is, indeed, more commonly found in connection with gold and lead than with any other minerals. Yet, despite this combination, there is a natural distinction between the veins of the several metals. In Nevada, Arizona, and New Mexico, for instance, the prevailing ores of precious metal are distinctively silver, the gold usually occurring in minute particles entangled in the sulpho-salts of silver and other metals, the weight of silver being greatly in excess of that of gold. On the other hand, in the California gold-belt gold occurs as flakes or even masses with only a small percentage of sil-

ver alloy. The main sources of the world's supply of silver for two hundred years after the discovery of America were Mexico and South America, but the mining enterprise of the United States within recent years has developed vast deposits in the mountains of the Pacific slope, and the yield of this country is now considerably in excess of that of any other.

Of the silver-producing fields of the United States the valuable mines of Nevada are situated on the eastern slope of the Sierra Nevada Mountains, nearly opposite to the centre of the California gold deposits on the western slope. Here, much to the surprise of prospectors, were found vast deposits of ore, which quickly dispelled the formerly prevailing theory that silver exists in the United States only in small quantities in connection with other ores. In 1859 two prospectors, Comstock and Jenrod, found on Mount Davison, near the shelf on which Virginia City is now built, what seemed "a vein of very dark ore." Specimens of this were sent to San Francisco for assay, and proved to be quartz rich in silver. The news of this discovery quickly spread, and miners flocked to the new silver locality in multitudes, the whole mountain being soon staked out in claims. Of the several veins that were opened, the richest was that since so well known as the Comstock. Here the dip of the ore is almost perpendicular, and the expense of working the vein has proved very great. Other veins of silver ore run parallel to this along the eastern slope of the mountain, there being several such belts of ore which are nearly one thousand feet long and have been traced nearly four miles in different directions. In some cases these veins have been reached by horizontal drifts in the mountain-side, their great dip rendering this feasible.

During the period since the opening of these mines about \$300,000,000 in value of silver have been taken from them, though recently there has been a decided falling off in the output of the Comstock lode. As the depth of the workings made the requisites of ventilation, pumping, and raising the ore very expensive, it was decided to excavate a draining and ventilating tunnel to the several veins. This has been accomplished by the remarkable Suro tunnel, which enters the mountain-side 2000 feet below Virginia City, and is 14 feet wide, 12 high, and nearly 5 miles long, with numerous lateral galleries. Along it passes a double-track tramway to carry out the ore, with water-drains on each side, while the mines, once almost unbearable in temperature, are now cooled and ventilated. There are several other silver-mining localities in Nevada, Eureka being an important one, and the silver yield of the State is about three times its production of gold.

The mines of Arizona were first discovered about 150 years ago by adventurous priests who brought to Mexico marvellous tales of the wealth of native silver in the mountains of the North. Multitudes of Spanish adventurers flocked to this locality, and worked the mines for nearly a century, at the end of which time the Indians, whom they had forced to work for them, rose and drove them off. When the United States obtained possession of Arizona there were no mines in operation, the Apache Indians having full control of the country. These savages gave great trouble to the early American miners, yet the old Mexican mines were gradually opened, and worked successfully, while new discoveries of rich deposits, often of almost pure silver, were made. The richest deposits of Territory are near the town of Tombstone, where high-grade and easily worked ores exist abundantly. The mineral belt of Tombstone is about 8 miles wide, from east to west, and 25 miles long, embracing an area of nearly 200 square miles. Hither miners have flocked in numbers, and the veins have been extensively worked. About 200 miles easterly from Tombstone, in the Lake Valley

mining district of New Mexico, exists another remarkable deposit, whose ores are said to be very rich and abundant. At various points in the Valley of the Rio Grande are other silver-ore veins, and the indication is that the whole region of Western New Mexico and Eastern Arizona is rich in metallic veins.

Nearly due east from the rich silver deposits of Nevada, and about eight hundred miles distant, exist the mines of Leadville, Colo., the most productive silver mines yet opened in the United States. These are in the Rocky Mountain region, and the ore differs from that of the Sierra Nevada by being associated with lead instead of gold. The lodes here are comparatively horizontal, and operations much less expensive than at Virginia City, so that the mines are worked to a much greater extent by individuals and by companies of small capital. The product of the United States hitherto has been principally from these two regions, though of late years the Nevada yield has fallen off and that of new regions grown into great importance.

Of these newer localities may be particularly named Utah and Montana. The latter Territory is now second in product to Colorado, it having several valuable mining districts, the richest in silver being the Granite Mountain, the Anaconda, and the Alice mines. In Utah, which now comes third in silver product, the veins are scattered over the Territory, though much the richest deposits are in Summit County, the Ontario mine being now the principal producer, the Horn Silver mine, once a strong rival, having dropped from competition. The silver here is in connection with lead, as in Colorado. Idaho has rich silver deposits, in combination with gold. In Wyoming the gold is more promising than the silver, in one locality the silver being connected with copper, below which are veins of native silver, and still farther down silver and gold combined. There is probably very little silver in Oregon and Washington, and no promising show in California, nearly all the silver from that State coming from the mines of San Bernardino County. One-third of all the gold and one-half of all the silver annually produced in the world are supplied by the mines of the United States. The mining laws of the United States permit miners to go upon the public domain and work mines without restriction or payment of royalty. This is different from the custom of other governments, and unfair to the interests of the remaining people of the country, yet it has had much to do with the remarkably rapid development of our rich mineral resources.

The value of the output of the principal silver-producing States and Territories and of the whole United States for the year 1886 was as follows:

Colorado.....	\$18,209,406	California.....	\$1,610,025
Montana.....	13,849,930	Dakota.....	422,581
Nevada.....	6,051,596	Idaho.....	94,022
Utah.....	5,539,940	Other States and	
New Mexico.....	2,701,741	Territories.....	110,873
Arizona.....	2,305,420		

Total United States product..... \$50,896,124

The following table gives the production in the silver-yielding countries of the world for 1887:

United States....	\$51,600,000	Russia.....	\$616,424
Mexico.....	32,111,778	Argentine Repub-	
Bolivia.....	16,000,000	lic.....	478,075
Chili.....	6,649,000	Italy.....	432,140
Germany.....	5,915,600	Africa.....	392,218
Spain.....	2,258,163	Great Britain....	316,021
Austria-Hungary..	2,060,900	Norway.....	290,292
Peru.....	1,987,500	France.....	245,412
Australia.....	1,048,279	Brazil.....	169,500
Japan.....	959,413	Sweden.....	96,697
Colombia.....	700,000	Turkey.....	55,420

Total world's production.....\$121,422,342

(C. M.)

SIMON, JULES, a French statesman and philosopher, was born at Lorient, Dec. 27, 1814. His family name was Suisse, but from childhood he bore the name Simon, by which his father had come to be known. His early studies were at the college of his native town and afterward at Vannes, and he had already taught at Rennes before he attended the Normal School at Paris in 1833. Having taken his degree in philosophy in 1833 with a thesis on Proclus, he taught at Caen and Versailles. Then he was recalled to Paris by his former master, the distinguished Cousin, whom he succeeded at the Sorbonne in 1839. For twelve years his lectures were attended by enthusiastic students, till the *coup d'état* of 1851 caused them to be suspended. To this early period of his career belong his treatises on ancient philosophy, *La Théodicée de Platon et d'Aristote* (1840), and *Histoire de l'École d'Alexandrie* (2 vols., 1844-45); his editions of the French philosophers, Descartes, Bossuet, Malebranche, Arnauld; and a *Manuel de Philosophie* (1847). Denied under the Empire an opportunity of teaching, he began in 1855 to conduct courses in philosophy in the principal cities of Belgium. These proved highly successful and gave him a wide reputation. His visits to Belgium also had a favorable effect on his mind, by showing him the practical effects of religious liberty. His lectures of this time furnish the material of his books, *Le Deroir* (1854); *La Religion naturelle* (1856); and *La Liberté de Conscience* (1859). A larger work, *La Liberté* (2 vols., 1859), he subsequently divided under the titles *La Liberté de Penser* and *La Liberté civile*. When the Empire seemed to have become established the government's pressure was relaxed. In 1863 Simon was elected to the Corps Législatif, and soon became the leader of the Republican party. This position was due not merely to his ability as an orator but to his intellectual force. He sought to base political acts on philosophical principles. These he commended to the people in a number of treatises, in which he discussed the questions of labor, compulsory education, and the various elements of the radical policy. The general elections of 1869 showed the advance of his popularity and of the Republican party. His name was proposed in several departments, and he was elected in two. The Republican opposition to the declaration of war against Prussia could not prevent Napoleon III. from rushing on his fate. After the downfall of the Empire, Simon took part in the government of the national defence, the ministry of public instruction being appropriately assigned to him. Too moderate to suit the communistic tendency of Paris, he failed of election there in February, 1871, but was chosen from Marne. In President Thiers' cabinet of that year he was again minister of instruction. His wise measures gave a beneficial impulse to both primary and higher education. When in May, 1873, Marshal MacMahon succeeded to the presidency, Simon, in the Corps Législatif, became the leader of the Constitutional Republicans. To him may be ascribed the defeat of the combined attempts of Bonapartists, Orleanists, and Legitimists for the restoration of monarchy in the following autumn. In 1875 he was elected a senator for life, and on the same day a member of the Academy. Thus, as the witty French expressed it, "One day rendered him irremovable and immortal." His aim at this time was to unite all the Republican groups, but the Radical tendency was too strong. In December, 1876, Marshal MacMahon yielded so far as to call Simon to form a cabinet. In this he had the portfolio of the interior. The marshal again yielded so far as to dismiss from office some who were obnoxious to the Republicans. But in the severe struggle which soon arose with the clericals, the Marshal-President favored them, and found in a trifling accident an opportunity to ad-

minister a public rebuke to Simon. The latter therefore resigned, May 16, 1877. In the following September, after the death of his friend Thiers, Simon pronounced his eulogy. The reactionary MacMahon resigned and the true Republican Grévy succeeded to the presidency. Simon was selected to lead the movement for the transfer of the seat of legislation from Versailles to Paris. Still a firm but moderate Republican, his prudent conservatism brought him into conflict with the progressive Radicals. He resisted the effort to exclude the religious orders from the work of education, and to banish the non-authorized bodies from France. He also resisted the movement for complete amnesty to the Communists of 1871. The Academy chose Simon in 1880 a member of the supreme educational council. In 1882 he was made permanent secretary of the academy of moral and political science.

Simon's philosophic works and his earlier political and economic writings have already been mentioned. After the establishment of the Republic he published some treatises on education and historical memoirs. These comprise *Souvenirs du 4 Septembre* (2 vols., 1874), relating to the downfall of the Empire and the government of the National Defence; and *Le Gouvernement de M. Thiers* (2 vols., 1878). Besides a manual of civics for schools, *Le Livre du Petit Citoyen* (1883), he published *Dieu, Patrie et Liberté* (1883), in which he set forth, with characteristic eloquence, the great moral ideas which have ruled his life.

SIMPSON, MATTHEW (1810-1884), a bishop of the Methodist Episcopal Church, was born at Cadiz, Ohio, June 21, 1810. After graduating at Madison College, Hamilton, N. Y., he taught there for a time. In 1837 he was called to be professor of natural science in Allegheny College, and in 1839, after he had entered the ministry, he was made president of Ashbury University, Indiana. As a delegate to the General Conference of 1841 he took part in the controversy on slave-holding which divided the Methodist Church. At the Conference of 1848 he was made editor of the *Western Christian Advocate*, and at the next Conference, in 1852, was chosen bishop. His residence was fixed at Philadelphia, but he spent much time in foreign journeys, one of which extended around the world. His visit to the British Wesleyan Conference in 1863 gave him an opportunity to plead effectually abroad the cause of the U. S. government in regard to the civil war, as he had already done at home. In this cause his oratorical abilities received wide recognition, yet he never neglected his work as bishop and preacher of the Gospel. President Lincoln treated him with marked cordiality, and the Christian Commission had in him a warm advocate. In 1881 he was one of the leaders in the Methodist Ecumenical Conference at London. He died at Philadelphia, June 17, 1884. He published a *Hundred Years of Methodism* (1881), *Lectures on Preaching* (1883), and a *Cyclopedia of Methodism*.

SIMS, JAMES MARION (1813-1883), physician, was born in Lancaster district, S. C., Jan. 25, 1813. He graduated at South Carolina College in 1832, studied medicine in Charleston and Philadelphia, and began practice at Montgomery, Ala. Having made a specialty of diseases of women, he established a private hospital for the purpose, which proved eminently successful. In 1853 he removed to New York City, where he urged the necessity of such a hospital, and had the satisfaction of seeing it opened in 1855. Dr. Sims had already invented the vaginal speculum and made improvements in surgery which gave him international fame. On his first visit to Europe, in 1857, his professional brethren showed their respect by asking him to perform important surgical operations. For some years he resided in Paris, and in

the War of 1870, he organized an ambulance corps. He returned to New York soon afterward, and died there Nov. 13, 1883. His publications were chiefly professional, and after his death a volume called *The Story of My Life* appeared, edited by his son (1884).

SIOUX, the principal tribe of the Dakota family of Indians, were called by Father Hennepin (1680), Nadouewessians, and by Captain Carver (1766), Nadouessionx. This was the name given to them by the Algonquins, and meant "enemies." Their own name, Dakota, meant "confederates." For their general character and customs, see **DAKOTA INDIANS**. In 1815 the U. S. government first negotiated with them, making three treaties with three separate bands. In 1825 four treaties were made. The Ojibways, or Chippewas, were then steadily forcing the Sioux southward and westward. In 1830 the latter made to the U. S. government their first cession of lands, between the Mississippi and Des Moines Rivers, and were to receive certain annuities, to be divided between the different bands. Soon after this the artist Catlin visited them, and painted portraits of their chiefs. He speaks of them in terms of high praise. In 1837 thirty Sioux chiefs visited Washington and ceded all their lands east of the Mississippi for the sum of \$300,000, the interest of which was to be paid annually, while other sums were devoted to paying the debts of the tribe and giving them an outfit for civilized life. The effort to turn the Sioux from hunters into farmers was not successful, probably owing to the agents employed as well as the character of the Indians themselves. They were demoralized by the introduction of whiskey, and were constantly attacked by other tribes. In 1849 a new cession of their lands in Minnesota, west of the Mississippi, was made. At this time arrears of interest due them by treaty amounted to \$50,000. The half-breeds made efforts to have assignments of land made to them in severalty and in fee-simple, but the government refused. Treaties, however, were made in 1851 by which many millions of acres forming "the garden-spot of the Mississippi Valley" were relinquished for a few cents per acre. The largest part of the price was to be held in trust, and the interest paid to the Indians for fifty years. Governor Ramsey, of Minnesota, estimated the actual cost to the government to be \$575,000. The four great bands of the Sioux, then numbering about 8,000, were to be brought together on one reservation, and a brilliant future was promised them. They had already made some progress in agriculture and education. It soon appeared that the government intended to remove them to other places at the end of five years, and hence their disposition to improve the land of the reservation was checked. In 1854, however, this impediment was removed and they were assured of a permanent home. In 1857 serious trouble was threatened and with difficulty avoided. Some Sioux who had been driven out of the tribe long before got into a quarrel with a few whites, attacked a settlement, and killed the inhabitants. The great body of the tribe, though discontented on account of the non-payment of the annuities, and regarded with suspicion and hatred by the whites, pursued and killed or captured the offenders. The excitement passed away, and soon most favorable reports were received of the progress made by the Sioux in learning civilized ways. But their annuities were still delayed until in August, 1862, some desperate, famishing men broke into a government warehouse. In a few days their numbers increased, and they began to massacre white settlers. Friendly Indians were threatened with death if they did not join the savages. Nevertheless, many of them rescued white families, and gave shelter to women and children. The hostile bands roamed over the country and compelled the abandonment of a district 200 miles long and 50

miles wide. A thousand whites were killed in the war and millions of dollars' worth of property was destroyed. Gen. Sibley conducted a successful expedition against the Indians. Hundreds of them were captured, and many voluntarily surrendered. A military commission sentenced 300 to be hung, but only 39 were executed. The friendly part of the tribe, who had to be protected from the indiscriminate fury of the whites, had been placed in a barren district in Dakota, where they endured privations for three years. Many of the hostiles escaped into the British dominions and settled there. The campaign had cost the government \$40,000,000. In 1865 resort was had again to peaceful negotiation, and nine treaties were made with as many different bands of Sioux. In 1866 the friendly Indians were removed from Dakota, and carried about almost every year to a new locality. For ten years the policy of the government wavered between severity and kindness, while the Indian and the War Departments disputed where the blame should rest. About 1870 the Santee Sioux began that change for the better whose results are shown in the article on INDIANS, Vol. II., p. 401. Near the northern border of Dakota, Sitting Bull and others had remained in hostility. The failure of the government to send supplies to the agencies caused many young men to join the hostile camps. In 1876 war began again, and its most appalling incident was the massacre of Gen. G. A. Custer and his command on June 26th. In October Col. Miles had effected a complete defeat of the Sioux, but Sitting Bull escaped into Canada, and scornfully refused to return when invited. The government then decided to re-establish the Sioux, to the number of 14,000 souls, on the Missouri River. Between 1863 and 1879 the Ogallalla Sioux were moved eight times. Their present condition is shown in the article INDIANS. See also the *Reports of the Commissioner of Indian Affairs* for various years; Mrs. H. H. Jackson's *A Century of Dishonor* (1881); Col. G. W. Manypenny's *Our Indian Wars*.

SIOUX CITY, the county seat of Woodbury Co., Iowa, is on the east bank of the Missouri River, between the mouths of the Floyd and the Big Sioux Rivers, 125 miles above Omaha. Five trunk-line railroads pass through the city, and several branches start from it. A railroad bridge 2000 feet long here crosses the Missouri. Sioux City has a court-house, city hall, hospital, 2 large hotels, 8 banks (3 National) with combined capital of \$2,000,000, 27 churches, and good public schools. It has a linseed-oil mill, 2 flouring mills, vinegar works, spice mills, soap factory, planing mills, and sash and door factories. With the Union stock-yards are connected large packing-houses, capable of packing 14,500 hogs and 2000 cattle daily. The total trade of the city for 1887 was \$8,500,000. The city is 1,100 feet above the sea-level and has a total area of 30 square miles. It has 60 miles of graded streets, 15 of which are paved with cedar blocks. There are 12 miles of street railway, and a good system of sewerage. The property is assessed at \$8,000,000; the public debt is \$486,000, and the yearly expenses exceed \$135,000. The city, laid out in 1854, was made the county seat in 1856, and was incorporated in 1857. Sioux City in 1880 had a population of 7336, but has since grown rapidly.

SIX NATIONS. See IROQUOIS.

SKATING. See SPORTS.

SKEAT, WALTER WILLIAM, an English etymologist, was born in London, Nov. 21, 1835. He was educated at Highgate School, London, and at Christ's College, Cambridge, where he graduated in 1858. He studied theology and was ordained in 1859, and held two curacies. In 1864, being laid aside from clerical work by diphtheria, he edited *Launcelot of the Laik* for the *Early English Text So-*

ciety. Other works followed, and Mr. Skeat began to prepare a glossary for the various works he had examined. He also edited Barbour's *The Bruce*, Chatterton, and the Anglo-Saxon Gospels. He founded the English Dialect Society in 1873 and directed its labors for three years. His most important work is the *Etymological English Dictionary* (1880).

SKENE, WILLIAM FORBES, a Scottish historian, was born at Inverurie, Kincardineshire, June 7, 1809. He was educated at the Edinburgh High School and at the Universities of Edinburgh and St. Andrew's. He became a writer to the signet, and devoted much attention to historical and antiquarian research. Besides several monographs, he has published *The Highlanders of Scotland: their Origin, History, and Antiquities* (2 vols., 1837); *Celtic Scotland, a History of Ancient Alban* (1876-80). The latter is in 3 volumes, treating respectively of the History and Ethnology, Church and Culture, and Land and People. Mr. Skene also edited the early Scotch historians. His labors have thrown much light on what was formerly obscure and confused in the history of Scotland.

SKINNER, THOMAS HARVEY (1791-1871), Presbyterian minister, was born in North Carolina in 1791. He graduated at Princeton in 1810, and was made copastor with Dr. T. L. Janeway, in Philadelphia, in 1812. Four years later he withdrew with part of the congregation and formed the Arch Street Presbyterian Church. He was afterward professor of sacred rhetoric in Andover Seminary, and in 1835 became pastor in New York City. In 1848 he was made professor in the Union Theological Seminary, and held this position until his death, Feb. 1, 1871. Among his publications, besides sermons, were *Preaching and Hearing and Discussions in Theology*.

His son, bearing the same name, was born at Philadelphia, Oct. 6, 1820. He graduated at the University of the City of New York in 1840, and was ordained pastor of a Presbyterian Church at Paterson, N. J., in 1843. He afterward held charges in New York City, Honesdale, Pa., Stapleton, L. I., Fort Wayne, Ind., and Cincinnati. He was called thence to be professor of didactic and polemic theology in the Presbyterian Theological Seminary of the Northwest.

SLANG. See AMERICANISMS.

SLAVERY, in the most general sense, implies a relation between persons under which the conduct of one is subject to control by another in a manner unlimited, except under some source of authority or necessity external to the relation. Where the form and qualities of that relation are prescribed by a system of laws to which the parties to the relation are subject, the term slavery expresses an institutional idea that transfers the sanction of the rights and obligations incident to it from what is involved in the relation itself to the system of laws under which it exists. It is in this institutional sense that the term is ordinarily used, and is here employed. We are to consider slavery as a civil institution, either intended to advance the general social objects for the sake of which governments are organized, or remaining as a survival of antecedent unorganized conditions, and in this light to examine the characteristics of that type of the institution that became domesticated in America, but which has now disappeared from the United States, and from nearly the entire continent of America.

The slave relation is, according to the general estimation of the law of Europe and America, based upon an obligation on the part of the slave to exercise his entire capacity of labor and service for the benefit of the master, and under his direction, without compensative return. On the other hand, the

master was regarded as bound to supply to the slave the simplest and least costly means of supporting his capacity for labor, in the form of shelter, clothing, and food, while under no obligation to promote the conditions for the development of those higher powers that are dependent upon mental culture. The means for compelling conformity on the part of the slave with his obligations were abundantly provided by the law, as the master was permitted to exercise the full extent of the coercive and punitive power required for that purpose. On the other hand, the means afforded by the law for compelling the master to perform the obligations incumbent upon him, as incidental to the relation, were wholly inadequate to satisfy the idea of justice as applied by those systems to all other classes of persons. In the most advanced communities that recognized the system, only the most aggravated disregard of his obligations, on the part of the master, and such acts as shocked the sense of the community, as gross departures from what was sanctioned by its common habits, were the subjects of legal inquiry or redress. Taking the life of a slave, or subjecting him to tortures tending to impair his capacity for labor, was clearly not means appropriate to secure from the slave the proper application of his powers to the service of his master, and accordingly such acts were discountenanced and frequently punished. But, although the law thus intervened for the protection of the slave, the wrongs done to the community were the only ones redressed, the slave receiving no compensation for what was unlawfully denied or inflicted upon him. Had the systems maintaining such relations between the master and slave regarded the slave as a mere object of property, such as a domestic animal, the absence of any attempt to extend the principles of justice to ameliorate the conditions of the slave might be accounted for; but such was not the case, for slaves were regarded as persons, and although not entitled to the privileges that were enjoyed by all other persons, were frequently held accountable for their conduct, as bound by the same obligations that affected all others.

The most striking feature of the slave system is the fact that it removed from the social mass of the slaves the germ from which all institutional forms and organisms spring—the family. The uncertain tenure by which the slave family cohered, being liable to dissolution at the caprice of the master, or as his necessities or interests might require, prevented that stability in domestic relations without which social development is believed to be impossible. The family may be regarded as the organic unit of society from which all other institutional forms are derived by differentiation, just as the leaf supplies the same function to vegetal growth, and if the bud, which is the incipient leaf, is suppressed, development is impossible. When slavery theorized at all it regarded the family of the master as including all the persons subject to his authority, and as displacing all subordinate family groups, referring the idea to the patriarchal practices. The effect of this was to remove the conditions of development from the inferior mass, and to leave only the possibility of advance as an adjunct of the superior system.

It appears, then, that the characteristic feature of slavery was that it deprived the social mass, represented by the slave, of the capacity of development from its own internal conditions, while at the same time it placed that mass in such imperfect communication with the superior civilization that the benefits possible from such contact could not be realized. It is observed, of all relations between social bodies, that the first step toward interchanging whatever either may possess to the advantage of the other is to establish justice between them, and this is as true of the interchange of ideas and habits as it is of

merchandise. As, then, the same principles of justice that were recognized in the relations existing between the members of the superior civilization were not extended to the intercourse with the inferior, it was against natural tendencies to expect that the relation between the civilization of the master and the unstratified social condition of the slave should produce other than small results for good upon the condition of the latter.

Slavery as it existed in America was not a general system such as might be applied equally to all persons standing in like conditions, but was what might be called a personal system, being a relation between the white man and a particular race of people, namely, those of African descent. Although the spirit of our laws was dictated by the spirit of liberty that all mankind should stand together in the same civil society under laws affecting all alike, who were in like conditions, yet for some reason we have excepted from the benefits of that system the African people of this country who were held as slaves, and have given no satisfactory reason for that exception, although, in order to commend that system in the estimation of peoples who have not accepted it, it would seem to be required that such reasons should be given in a satisfactory form. We can say that certain facts did not afford the reason of such exception. For instance, it was not the fact of difference from our race and color, for other races differing in these respects from us were not excluded from the benefits of our system of laws. It was not the undeveloped condition of the African, for other peoples equally undeveloped have been admitted to the privileges of our laws. It was not that the African had thrust himself into our society unfitted for association with us, and to be isolated as a means of compelling him to withdraw from us, for we had brought him here against his will, and had paid for the privilege of so doing. There is no other mode of accounting for the anomaly but on the ground that the African was procured as a profitable investment of money in a cheap instrument of industry.

The African slave first came to the soil of the United States from the West Indies, where he had been introduced as an object of traffic. No doubt, when the opportunity presented itself for supplying with labor a country that abounded with natural resources but lacked laborers, a humane as well as a thrifty motive affected the people of our country, prompting them to accept the advantages of the system. The deplorable condition of the African slave, both in his own country and in the West Indies, appealed to the humane sympathies of our ancestors, who saw an opportunity of getting gain and doing a godly act for the oppressed in getting them better masters, and a chance for attaining to a higher condition of manhood.

From being a convenience the slave became a necessity, in a semitropical region, especially as connected with the rice-culture, that was fatal to the white laborer. By the time that the convention of 1787 was held to frame the Constitution of the United States the sentiment as to the status of the slave had changed somewhat. Where he was not a necessity of industry the old humane feeling prevailed, as evidenced in the debates in that convention, but where climatic causes made him a necessity the humane sentiment had been largely displaced by economic ideas. This consequence follows wherever thrift and humanity are combined motives to action, the dominant force remaining invariably in the hands of the former. These two motives, the one derived from the force of humane ideas, and the other from economic promptings, were destined to be arrayed against each other in a prolonged struggle in which the higher principle would ultimately prevail.

At the foundation of the government of the United States the conflict was already formulated in its incipient stages. England had already, through her judiciary, declared that slavery could not exist under the laws of that country, thus emphasizing that aspect of slavery that concerned its relations to the principles on which the higher form of organized government depended. The question of its humanity became involved with that of its effect upon the condition and objects of government, as interpreted from the principles of liberty.

The history of the development of American slavery is the history of its territorial extension, for as a social system it exhibits no progressive steps of advance toward anything that may be esteemed as the ideal of the system. Had there been any possibility of its taking on a character in harmony with advancing conceptions of society, American faculty would doubtless have found the means of advancing toward that result. The inability of American ingenuity to raise the institution of slavery from a lower to a higher plane emphasizes the conclusion that it is to be regarded as a survival of savagery capable of no permanent place in the scheme of civilization, but destined for elimination. The history of slavery in the United States exhibits a dual contest, on the one hand for its territorial extension in order to entrench it in popular interest and favor, and on the other to eliminate it from the system of the country.

The cession by Virginia to the United States of the territory northwest of the Ohio River brought the subject of the extension of slavery over the territories into active discussion. This cession was followed by the ordinance for the government of the Northwest Territory, that declared that slavery should be forever excluded from that territory. This ordinance, speaking as it does the sentiment of the people of the United States, condemns in effect the institution of slavery as unsuited to harmonize with the spirit of American liberty, and as justified where it should continue to exist by local causes alone. Unless the ordinance can be interpreted in this sense it cannot be rationally interpreted at all.

The Constitution of the United States, framed in the same year with the ordinance just mentioned, 1787, declares that Congress should not interfere with the migration or importation of such persons as the States should see fit to admit prior to the year 1803.

It has never been questioned that this had reference to interference with the African slave-trade, but was masked under this form out of decent regard for the opinions of mankind. This provision was clear authority for Congress, after the year designated, to prevent the introduction of slaves into the United States and to prevent their migration from State to State and into the territories. That Congress had after that time such authority as to the importation of slaves was never seriously questioned, but that Congress could prohibit the owners of slaves within a State from migrating with his slaves into the territories of the United States was resisted so long as the slave-holding States could influence the course of public action. The necessary implication from this clause is that the slave-trade was regarded as a necessary evil that must be endured for a time for economic reasons, after which it would be regarded as a crime to do that the doing of which was the occasion of the existence of slavery in this country. There was also in the provisions relating to migration a clear implication of a policy of limiting the area of slavery, which could only be extended by such migration.

The Constitution also contained a provision making it the duty of some public authority to return

slaves escaping from one State into another to the State from which they came, but the authority by which such return was to be accomplished was not pointed out. Upon the principles of strict construction for which the slave States always contended, this duty devolved upon the States, as no express authority was conferred upon Congress for that purpose, and as Congress, according to that view, could not take substantive powers by implication but only such as are in aid of the enumerated powers, as necessary to their exercise. The power of rendering fugitive slaves was not in the class of the enumerated powers, and was not in aid of any enumerated power. Although inconsistent with the principles which they applied to the construction of the Constitution, the party of strict construction in later years claimed that this power and duty devolved upon Congress, and actively procured the adoption of a fugitive-slave law in conformity with that view.

The first Congress assembled under the Constitution re-enacted the ordinance for the government of the Northwest Territory with the same exclusion as to slavery that existed in the previous ordinance, reiterating the implications already pointed out.

North Carolina in 1787 ceded her Western lands to the United States, with a provision that the slaves within that territory should not be emancipated. The cession by Georgia of her lands west of her boundaries followed in 1802, without any clause excluding slavery.

The condition attached to the cession of North Carolina tied the hands of Congress as it regarded slavery within the region ceded, but not more effectually than they were tied by the state of parties in the Union through the large influence of the slave-holding States, making the absence of such a condition in the Georgia cession a fact of no importance.

The purchase of Louisiana, consummated by President Jefferson in 1803, opened wide the door of controversy to the parties that respectively supported and antagonized slavery. The territory thus acquired supported the institution of slavery, and was largely subject to the same climatic conditions that had caused slavery to become deeply rooted in some of the Southern States.

Slavery was taking a new phase, and assuming definitely an aggressive *rôle* in the interest of its territorial extension. The invention of the cotton-gin had rendered the separation of the fibre of cotton from the seed an inexpensive process, instead of a laborious and expensive one, as it had theretofore been. The culture of cotton in the United States, from being an experiment, passed into a great industry that revolutionized not only the industry of the Southern section of the Union, but its political condition as well. Slave labor was regarded by the cotton States as indispensable to the success of that industry, and the perpetuation of slavery was the leading tenet of the new doctrine. The advocates of slavery found it necessary to strengthen the position of the slave interest on two sides, the moral and the political. It was habilitated as a patriarchal institution commended by the sacred writings, held in the highest estimation by Christianity, just as at a later time was contended in behalf of polygamy. The ideal of slavery was traced in the relations between a beneficent and just master and a faithful and loving slave, just as monarchy has been idealized in the charming picture of a just and generous king having no interest but the interests of his loving subjects, who thrive under his genial away as plants in the sunlight.

Whether this line of speculation was intended as apologetic or to dominate the thought of the nineteenth century, it was insufficient to provide the security that slavery needed. The country was becoming populous and spreading over a vast area.

It was foreseen that popular support in favor of slavery could not be relied upon, unless the majority had a stake in its perpetuation, and this could only be secured by its territorial expansion.

In the meantime the sentiment hostile to the institution was passing toward definite crystallization. Respect for the Constitution and for the rights of the States under it retarded the action of causes that looked to the elimination of slavery. The scheme of colonizing the African in Africa, as means of preparing the way for more energetic measures, was conceived and put in course of execution, and the colony of Liberia established on the West African coast. The difficulties attending the emancipation of the slaves, from the fact that they could neither become assimilated with the populations of this country in their new condition, nor find a refuge suited to their condition elsewhere, was foreseen and attempted to be guarded against by this expedient. But the scheme of colonization failed to discover that the chief difficulty in the way of the emancipation of the slave did not lie in the question of his disposition after emancipation, but in the unwillingness of his master to part with him.

The ultimate disposal of the territory derived from the Louisiana Purchase caused great agitation as bearing upon the question of the extension of the area devoted to slavery. Louisiana and Arkansas were carved from this territory without precipitating any serious conflict, as the institution had already become firmly fixed upon them. The geographical position of this region was recognized as creating a political necessity that no interference should take place with the condition of labor then existing there.

Missouri was admitted as a State in 1820, after a conflict that tested the relative strength of the opposing factions. Missouri approached the southern border of the region that antagonized slavery, and brought the conflict to its doors. A long-continued struggle between the parties seeking the admission of Missouri as a slave State, and those who sought to exclude from her limits that institution, ended in the famous Missouri Compromise, by which slavery was forever inhibited north of the line of 36° 30', except from the territory then constituted as the State of Missouri. The line of 36° 30' corresponded very nearly with the southern line of Missouri, so that the allowance of slavery within that State was an infraction of the uniformity of the geographical partition between the free and the slave States. Thus Missouri became the northern boundary of that part of the Union devoted to slavery that lay west of the Mississippi. Part of this compromise was a provision for the return of fugitive slaves escaping into the free States, that was to be regarded as a pledge binding the policy of those opposing the institution. Indeed, the entire compromise was intended to place the dispositions accomplished by it upon the good faith of the respective parties that had taken part in its enactment, for no one entertained the idea that the constitutional powers of Congress were in any way limited by it.

The Missouri Compromise, sustained for thirty years through the genius and labors of Webster, Clay, and Calhoun, deferred the inevitable conflict between the slave-holding and free regions, which finally arose with the first serious infraction of its provisions, until the Northern States had outstripped the Southern States in population and wealth, and were able to maintain in arms the indissoluble nature of our Union.

This important step taken in 1820 appears to have been the turning point in the development of the opposition to the institution. The agitation in behalf of the emancipation of the slaves throughout the Union, and as a preliminary to that step the

emancipation of the slaves within the territory that constituted the seat of government, soon after the event just referred to took on an organized form. In 1823 the first abolition convention met in Philadelphia.

That which had existed as a humane sentiment largely diffused through the free States began to crystallize into a conviction and policy that foreshadowed an aggressive movement for the extirpation of the entire system of slavery. That which had been nursed by humane sentiments struck its roots deep into conceptions of the principles that should govern the relations of mankind in their associations, and gave rise to utterances the intensity of which expressed not only the depth of the convictions from which they arose, but the passionate reactions from the barriers whose strength resisted the progress of the movement. The Constitution of the United States placed the internal economy of the States beyond the control of Congress, and thus the institution as it existed within the States could not be reached by the national power, even if that power could be wielded in the interest of free labor. Within the District controlled by Congress this power existed, but was in the hands of the partisans of the slave system and their political friends of the North.

The policy of agitation was the only course open to the advocates of emancipation, and that policy was pursued with vigor and industry that was untiring. Speeches, pamphlets, appeals and petitions to Congress for emancipation disseminated the ardent thoughts and feelings of the advocates of freedom, intended to fire the hearts of the people to a new crusade. These utterances were not confined to the people of the free States, but were delivered in the very midst of slavery and communicated through the press. Advocates of freedom were found with convictions so strong that they did not shrink from the dangers that attended personal contact with the adherents of the slave system. Retaliatory violence intensified the situation, firing the zeal of those who acted from enthusiasm, and alarming the timid and cautious. In Congress debate became altercation, especially when petition after petition poured in upon that body for some relief looking to the emancipation of the slave. The right of petition to the representatives of the people, that was part of our inheritance from England, seemed for a time in jeopardy. The threat of disunion came from the slave-holding States in an undertone that produced its effect upon many of the people of the Northern States.

The necessary consequence of such energetic movements, in a form that many could not distinguish from incipient revolution, was to produce a conservative reaction at the North, and to divide the sentiment of that section, thus complicating the situation, and for a time retarding the progress of the general feeling in favor of freedom to the slave. Apprehension for the safety of the Union, respect for the Constitution and the compromise that had at least served the purpose of separating combatants who might otherwise have met in dangerous collision, were part of the causes of a reactive tendency at the North, while political considerations looking to the solidity of party action had a large part in the result.

In this instance, as often happens, the conservatism of the North prevented the final issue of the conflict from being the direct consequence of aggressions on the part of the advocates of freedom, and the disaster to the Union that might have followed an aggressive policy of public action on the part of the Northern States at that time.

In the midst and heat of the conflict a train of causes was laid that tended by inevitable steps to the

final contest that eliminated slavery from the institutions of this country. Texas, largely peopled from the Southern States, had asserted her independence of Mexico, and was regarded as an acquisition to the Union that would strengthen the political power of the slave States. Texas, although free from slavery under Mexican rule, soon became the recipient of a slave immigration that fastened the institution upon her. The admission of Texas as a State of the Union was the result of the policy of extending the area of slavery, and was accomplished in 1845 after a struggle that laid the foundation of a recast in political parties that was destined to divide the politics of the country upon lines of difference between the advocates and opponents of slavery.

The Mexican War, that was a not uninvited consequence of the annexation of Texas, terminated with the acquisition of a vast territory that carried the western boundary of the United States to the Pacific. A new field was opened for the contest in behalf of the extension of the area of slavery. This acquisition came to us as free territory, and an early effort was made to have it so declared in perpetuity by Congress, under the name of the Wilmot Proviso. This effort failed, and soon the question of the organization of this vast territory was pressed upon Congress.

In 1850 the compromise offered by Henry Clay was adopted, which ignored the question of a determination by Congress of the character, as it regarded slavery, of the States to be formed from the territory acquired from Mexico by the treaty that concluded the war with that country, such action being based upon the idea that as slavery did not exist in that territory any declaration upon that subject was unnecessary. The South disputed this assumption that slavery did not exist there, claiming that when the slave-holder from the States carried his slaves into that region the guarantees of the Constitution went with him, thus creating there the rights incident to the slave system. The compromise of 1850 did not bring these opposite contentions to a test, and can only be regarded as an armistice before the great conflict that was soon to arise. That contest assumed a definite form when Kansas and Nebraska were organized as territories of the Union.

The assumption by Congress, as a federal duty, of the capture and return of fugitive slaves escaping into free States, by an act for the rendition of such slaves, intensified the bitterness of the contest that was raging through the country, north and south. Upon the question of the right of Congress to exercise this prerogative the interests of the parties were reversed. The party of strict construction insisted that Congress should claim and exercise it as a constitutional power, although not in the class of enumerated powers, and incapable of being regarded as a necessary incident to such powers. The party of liberal construction opposed it, both parties acting from their respective views of its policy rather than their view of its constitutionality. The attempt to execute this law produced a profound impression upon the Northern mind by acquainting it with the repulsive features of the slave system.

The organization of Kansas and Nebraska as territories, in 1854, was the pivot on which the fate of slavery turned. The Missouri Compromise was disregarded and the subject of the establishing or excluding slavery was left to the decision of the people of these territories. To this proposition, made by Stephen A. Douglass, the expression "squatter sovereignty" was applied at the North as expressing the uncertain character of the population to whom this important question was submitted.

This disposition was a logical consequence of the compromise of 1850, which, by withholding action on the part of Congress, necessarily left the matter

to the local authorities that should be thereafter instituted over those territories.

The struggle to colonize Kansas in the interest of the respective sections of the country was maintained by both parties in a desperate conflict that assumed the character of partisan warfare rather than that of civil competition. In the end the party of freedom prevailed, and Kansas and Nebraska came into the Union as free States. Of this conflict history must say that the party of slavery was contending for economic advantages, while the party of free labor was striving to vindicate a principle that was believed to be fundamental to all free society among men. Such conflicts are apt to produce that type of heroism that combines audacity with the spirit of self-sacrifice, even in the absence of the ability to measure enterprises by the means possessed for their accomplishment. Such a hero was John Brown, the product of the bitter strife, the passion, and the aspiration that mingled in the Kansas conflict. The project of organizing a band of slaves near the border of the free States to make their way to Canada carried John Brown to Harper's Ferry, where he paid with his life the penalty of grave miscalculations as to the aptitude of the negro to execute dangerous exploits in the interest of freedom.

The election of Abraham Lincoln to the Presidency in 1860 was the culminating point of the controversy. This event was interpreted by the slave-holding States as a presage of a change in the balance of power that would secure to the free States a controlling influence in the public affairs of the nation. The political ascendancy possessed by the Southern States from the formation of the Government, and which had been perpetuated through their political affiliations at the North, was seriously threatened through dissensions arising among these political friends. The aggressive character of the Abolition movement, as demonstrated in Kansas and in the hardy enterprise of John Brown, alarmed the slave-holding interest. The resolution of the leaders of Southern opinion was soon taken, and a policy of disunion was formed, and steps taken to bring the people of the Southern States to its acceptance. Popular acquiescence in this plan was by no means to be anticipated without effort and adroit management, as the mass of the people had not the motives impelling in the direction of disunion that affected the great slave-holders. A disposition was general to avoid independent State action, and to fix the policy of the Southern States in consultation among those States. Those who at heart desired to adhere to the Union, and yet feared to fall under suspicion of disloyalty to Southern interests, took the moderate position that whatever action was taken should be with the co-operation of all the slave States, and therefore upon consultation with them. The leaders of the movement in South Carolina were not willing to trust the question to the hesitation and delay incident to such formal action, but desired to precipitate a condition of affairs that would make the strongest appeal to the friends of Southern interests. Accordingly South Carolina passed in convention an ordinance of secession from the Union, and proceeded to arrest the exercise of the public functions of the National Government within her territories, and to appropriate the public property of the United States. Ten States followed South Carolina, and united with her in the constitution of the government of the Confederate States of America.

The war that ensued tested the relative value of the economic systems of the two sections. At the South the producing class, consisting of the slaves, carried forward the industries of the country almost without interruption. Food-supplies were abundant at the points of production, but were not available

to the armies in the field for want of transportation and system. At the North, on the other hand, large drafts were made upon the producing classes to supply men for the armies, and yet the industry of that section was maintained and its resources made available for the support of the war.

The first direct and important effect of the war upon the institution of slavery was accomplished by the Emancipation Proclamation of President Lincoln, issued Jan. 1, 1863. This proclamation, the product of the disasters of the early stages of the war, assured the emancipation of all slaves that should be within territory acquired by the arms of the nation. The end came at last when the entire territory of the seceding States was brought under the military power of the United States. According to the laws of war it was for the captor to determine the effect of conquest upon the persons and property found within the conquered territory. The terms of the proclamation indicated the course of military action toward the slave, and in accordance with its provisions the right of the slaves to their liberty was recognized and secured by the military authority. This action, while sufficient to change the status of all slaves upon whom it took actual effect, could not, and did not, change the local laws of the places subjected to the military power so as to prevent the future acquisition of slaves, those laws, according to the principles of international law everywhere respected, remaining in force until repealed by competent authority, and a military command was not competent to change them, except for the time of actual military occupancy.

In those States that adhered to the Union and in which slavery existed, the proclamation of the President and action in accordance with it could not produce the effect of emancipation.

The final act that terminated the existence of slavery in the United States was the Thirteenth Amendment of the Constitution, adopted by two-thirds of the States, that declared that neither slavery nor involuntary servitude, except as a punishment for crime, whereof the party shall have been duly convicted, shall exist within the United States or any place subject to their jurisdiction.

The estimation in which the institution of slavery is entitled to be held, as a social factor, must depend upon the solution of the question whether it is capable of being brought into harmony with advanced social conditions. If thus capable, that fact must arise from the possibility of developing the slave relation into a condition in which it will harmonize with the principles upon which advanced conditions of social order depend. What is implied by development, as applied to that institution, cannot admit of doubt. If the slave, separated as to his condition by a wide interval from that of the society that surrounds him, is found advancing so as ultimately to cancel that interval, if his relations with others, especially his domestic relations, are advancing in stability, and if the service and discipline to which he is subjected are, by progressive steps, allowing to its subject more favorable conditions of development, then it may be affirmed that the relation is capable of development in the normal sense. But if, on the other hand, the slave appears to remain stationary or to retrograde, and no indication appears of increased stability and organization in his domestic and other relations, and if the regimen to which he is subjected grows more and more repressive, then it may be affirmed that the institution, if fairly represented in the instance supposed, is incapable of healthful development, and that its presence in an advanced community is an evil the magnitude of which is measured by the extent to which it prevails.

Examining the history of the institution as it existed in the United States in the light of these

principles, it is possible to place upon it its proper estimation. For the purposes of such an examination neither the instances that exhibit slavery in the most favorable light nor those that display its worst features must be taken in view, but attention should be given to the mass and the system as a whole.

In the early days of slavery in this country emancipation was quite common, but during the later years of slavery the instances of that kind were very rare, in part through repression by law and popular sentiment in the slave States, and in part through the increased value of slave property. Emancipation and even removal from the State for the purpose of emancipation were in some instances forbidden by law.

The inability of the slave to hold property underwent no relaxation, but on the contrary there were instances where masters were prevented by the operation of law from making provision for the support of slaves. When it is considered how large is the civilizing influence resulting from the responsibilities attendant upon the ownership of property, it will readily appear that if any amelioration of the system was to be anticipated it would be in the respect just named.

So far from there being any indication of any increased stability in the domestic relations among the slaves, the contrary appears. In the early days of slavery in this country it was possible that generation after generation of slaves born in a particular locality might spend their lives in that locality, and thus produce the semblance of domestic stability, but in later years this feature had to yield to commercial necessity, and the slave population was increasingly mobilized from year to year.

In early times it was no offence against law or public sentiment to instruct slaves, and especially to teach them to read and write, but in later years that practice was discontinued either as contrary to law or to public opinion.

Without going further, it is manifest that slavery in America, although having abundant time to manifest its tendencies, did not give indications of any possibility of reaching a condition in which it would be but a single step for the slave to pass into fair relation with the civilization that surrounded him. It is likely to be said that the responsibility for this condition of affairs is with those who, by agitating the question of emancipation, forced the slave-holder into a defensive attitude that entailed these disadvantages upon the slave; that it was simply a matter of self-protection to exclude the slave from contact with the feelings that prompted the aggressions upon the institution, and to accomplish this it was necessary that he should be kept incapable of reading.

But these disturbing conditions of environment were the necessary consequences of the existence of the slave institution in the midst of a community animated by the spirit of liberty and addicted to modern habits of thought. Call the aggressor by what name you will, Abolitionist, or what may better describe him, and after all he stands merely as the type of a tendency, inherent in every healthful organization, to eliminate such elements as are unsuited for assimilation, and impede its functional activities. The very question as it regards the social quality of slavery is whether it is of such a nature as to produce such conditions in advanced communities surrounding it. Organisms that have any vital power must act in that way. Physiological laws demonstrate the principle as it acts in communities. If a substance is intruded in the animal organism that cannot be assimilated and that interferes with the performance of function, violent and inflammatory methods of elimination are set up, proportionate in their energy to the vigor of the system. Communities of men act from the same tendencies, produ-

cing for the purpose instruments of elimination not always of an attractive character. The failure of slavery in America to assume forms consonant with the principles of our civilization must be attributed to its inherent character and not to the accidental means of its elimination.

The mere fact that a mass of human beings was to be held in a condition of servitude in a community permeated by the spirit of liberty rendered it necessary that the slave should be isolated from the sentiment of such community, and for that purpose that his mind should be kept closed against its literature and habits of thought and action, and also that freedom of intercourse between the two classes should be excluded. It was therefore a necessity of the institution that the conditions of development for the slave should be suppressed, if it was to be indefinitely perpetuated.

Concluding then, as we must, that the institution of slavery is irreconcilable with social conditions of an advanced type, the aggressions upon it are accounted for by its nature. The necessities of slavery entailed changes upon the political institutions of that section of the country, not only by weakening confidence in the principle of popular government, but by encouraging the use of irregular means of maintaining the domestic police, tending to undermine respect for regular government, and thus to open the door to unrestrained popular violence. It was impossible for the isolation of the slave to be accomplished to the extent necessary to maintain the institution by the regular means supplied by government. It was not practicable to embody in laws all the requirements of such isolation, and nothing less than a militia on constant duty, and irregular bands of citizens daily and nightly on watch and guard, with their humanity as the only measure of their authority, could secure the conditions under which the institution could be perpetuated.

The reasons that have been stated sufficiently account for the observed fact that the influence of slavery upon the political institutions of the country was greater and more effective than that of these institutions upon the conditions of slavery.

Slavery has entailed upon the United States a social problem of the greatest magnitude and difficulty. In all of the old slave States a very large portion of the population consists of the former slaves and their descendants, and in several of them that population exceeds the residue. For all purposes of estimating the nature of this social problem these populations must be regarded as composed of two distinct social masses, separated by their interests, by their habits of life, by the broadest race-differences, and by the fact that one exhibits civil organization of which the other is destitute. They live in common a language and necessary relations of industry. The utmost conceivable departure from homogeneity exists in the case. It is not possible that within the same State two systems of social organization can coexist; one must give way to the other, or they must blend to form something distinct from each. The last condition named evidently cannot take place, and the organized condition cannot give way to that which is without organization. If a community of interest could be brought about the other points of difference would cease to be of importance. To unite these interests it is necessary that the civil and political rights of the weaker party should be fully respected, and in that event, in certain States, the population consisting of the former slaves and their descendants would have the preponderating political influence. Until such unity of interest occurs they would naturally use their political power to advance their own separate interests. While discriminations are made against

their political rights, their interests will remain separate and distinct from those of the residue of the social body.

In all these States the political power is in the hands of one of these masses, even in States where they are in the minority. The white people have been trained by the institution of slavery to believe that the principles on which social liberty is based have no application to the negro. They have never grasped the truth, that is the highest commendation of popular government, that although the uneducated and undisciplined are the majority in such a community, such is the influence of developed mental power that it is able to cancel the advantage of superior numbers in an elective system, and to exercise the preponderating influence. To remove the causes that tend to separate the two great sections of the populations is the proper means of testing the sufficiency of the principle just stated to secure good government. Mutual fear is the cause of separation, and mutual confidence will be the means of inducing a higher social order. (A. J. W.)

SLIDELL, JOHN (1793-1871), politician, was born in New York in 1793. He removed to New Orleans and entered successfully into the practice of law, serving as District Attorney of the United States from 1829 to 1838. He was frequently elected to the State Legislature, in 1843 was elected to Congress, and in 1845 was appointed by President Polk Minister to Mexico. In 1853 he became a member of the United States Senate, to which he was re-elected in 1859. He spoke rarely in the Senate, but served on important committees and exerted great influence. In politics he was a strenuous supporter of the Southern State-rights party, and after the secession of Louisiana, in 1861, he withdrew from the Senate. In the autumn of this year he was sent, in conjunction with J. M. Mason, of Virginia, to France as a commissioner from the Confederate States. They embarked from Havana in the British mail steamer Trent, which vessel was stopped by the United States frigate San Jacinto, Captain Wilkes, on November 8th, the commissioners being taken off in defiance of the protest of the commander, and confined in Fort Warren, Boston Harbor. This indefensible action was enthusiastically received in the North, but Great Britain sternly demanded the immediate release of the prisoners, with threats of war in case of refusal. The feeling of the people was not shared by the President and Secretary of State, who recognized that the demand of England was a just one, and that the capture was in opposition to the rules of international law, as interpreted by the United States itself in the events that led to the War of 1812. The commissioners were accordingly set free, and sailed from Boston for England, January 1, 1862. Slidell did not return to America, but resided in London till his death, July 26, 1871.

SLOAT, JOHN DRAKE (1780-1867), naval officer, was born in New York City in 1780; entered the navy as a midshipman in 1800, and was honorably discharged, 1801. In 1812 he re-entered the service as a sailing-master, serving on the United States, in which ship he was engaged in the action with the British frigate Macedonian, Oct. 25, 1812, when the latter was captured. For this he received a vote of thanks and a silver medal, and was promoted lieutenant. In 1824-25 he served in the expedition against the West Indian pirates and participated in the capture of the pirate brig Palmyra. In 1824, as commander of the schooner Grampus, he took part in the destruction of the town of Foxhardo, Porto Rico, the pirates' headquarters, and afterward captured a brig on which was their chief, Colfreicias, who was afterward executed. For his services he was promoted in rapid succession master-commandant and captain, and had charge of the Norfolk navy-yard from 1840

to 1844. He next commanded the Pacific squadron, and on the outbreak of the Mexican war occupied Monterey, and secured San Francisco and other places on the Californian coast. In 1847 he returned to the Norfolk navy-yard, where he was in command till 1851, when he went to Hoboken to superintend the construction of the Stevens battery (see STEVENS, JOHN). On July 16, 1862, he was made commodore (retired list), and rear-admiral July 25, 1866. He died at New Brighton, Staten Island, Nov. 28, 1867.

SLOCUM, HENRY WARNER, general, was born in September, 1827, in Delphi, Onondaga Co., N. Y. On his graduation from West Point, in 1852, he was appointed 2d lieutenant in the 1st artillery, and promoted to 1st lieutenant in 1855. Next year he resigned his commission and engaged in the practice of law at Syracuse, and in 1860 was elected to the legislature. On the outbreak of the civil war he volunteered his services, and in May, 1861, received his commission as colonel of the 27th N. Y. volunteers, which regiment he commanded at Bull Run, where he received a severe wound. Commissioned in August, as brigadier-general of volunteers, he was assigned to the command of a brigade in Franklin's division of the Army of the Potomac, and took part in McClellan's Peninsular campaign of 1862. On Franklin's assignment to the 6th corps in May, Slocum succeeded to the command of his division, and, being sent to re-enforce Gen. Fitz-John Porter on the east of the Chickahominy, rendered signal service at the battle of Gaines' Mill, June 27, 1862, as also at Glendale and Malvern Hill, in both of which engagements his division occupied the right of the main line. Promoted, in July, to major-general of volunteers, he took part in the second Bull Run fight, as also in the battles of South Mountain and Antietam, in the Maryland campaign, and in October was appointed to the command of the 12th Army corps. In this position he fought bravely at Fredericksburg, Chancellorsville, and Gettysburg, commanding, in the last of these battles, the right wing of the Union Army, and contributing in no small degree to the victory. His corps was thereafter transferred to the Army of the Cumberland, in which it served till April, 1864, when, on its being consolidated with the 11th, Gen. Slocum was assigned to a division and the command of the district of Vicksburg. Having, in August, succeeded to the command of the 20th corps, he was the first to occupy Atlanta, Ga., on Sept. 2d, in Sherman's march to the sea. In this grand progress, as well as in the march through the Carolinas, he commanded the left wing and took part in such actions as occurred up till Gen. Joseph E. Johnston's surrender at Durham Station.

In September, 1865, Gen. Slocum, for a second time, resigned from the army and again betook himself to the practice of law in Brooklyn, and was in the same year democratic candidate for the State of New York, but was defeated. In 1866 he was offered a commission as colonel in the regular army, but declined it. In 1868 he was presidential elector, and also in this year was sent to Congress, to which he was re-elected in 1870, and again in 1884. In Brooklyn he has held several prominent offices, having been president of the board of city works, and one of the commissioners of the Brooklyn bridge.

SMALL-POX (*Variola*): Cow-pox (*Vaccinia*).—Records of a disease identified as small-pox date before 1100 n. c. in China. Its progress westward was slow, for its first authentic appearance in Europe was in the sixth century A. D. It is known that the domestic animals, horned cattle, horses and sheep, are in some degree liable, each having a form of the disease varying from that of mankind and of every other. Monkeys are also somewhat susceptible. Small-pox is highly contagious through the

atmosphere and by inoculation, and transportable in fomites. The dark races of mankind are affected with greatest severity.

The period of incubation is about twelve days. Its access is rather abrupt, a brief rigor being followed by a high fever, severe pain in head, back, and extremities, vomiting and constipation—sometimes delirium and convulsions. On the third day a mottled-red eruption appears, more abundantly upon the face and hands than the covered parts of the body, and extending also to the mouth, pharynx and larynx. The eruption is at first papular, feeling like small shot embedded in the skin, gradually becomes vesicular with a central depression, which about the eighth day fills up, and the pock matures as a pustule. The fever declines on appearance of the rash, but reappears in the pustular stage, always in proportion to the irritation produced by the maturing pustules. The eruption is known as *discrete* when the pustules are distinct from each other, and *confluent* when they coalesce, and is often confluent on the face and hands and discrete on the body. The gravity of the case is according to the extent of the eruption. Scabs form on the discharged pustules, which leave, on falling, permanent depressions in the true skin. The duration of a natural case of discrete small-pox, from the initial rigor to the end of desquamation, is about four weeks; but the confluent form, in case of recovery, lasts longer and convalescence is tedious. The hemorrhagic form of small-pox is characterized by an eruption resembling at first that of measles or scarlatina, soon developing into small blisters filled with blood. Hemorrhages take place from various mucous surfaces. The temperature is lower than in other forms. The end is always fatal, and is reached from the fourth to the sixth day.

The most remarkable feature of small-pox is control over its severity by artificial production of a mitigated form. This was practised in Eastern countries from an unknown period, by inoculating the virus of human variola. On the second day a pimple appears which becomes vesicular on the fourth and pustular in three or four more. On the eleventh day a general eruption appears, but this is discrete, and recovery is almost uniform. Such a case is just as liable, however, to become a focus of infection as one of natural small-pox. Inoculation was introduced into England early in the 18th century, and was extensively practised in Europe and America until it was superseded by vaccination about the beginning of the present century.

A variolous disease prevailed extensively among horned cattle in Europe before the middle of last century, and it was known among farmers that milkers of variolous cows sometimes had pustules on the hands and were thenceforward insusceptible to small-pox. Artificial production of vaccine variola was proposed as a prophylactic against natural small-pox by Dr. Edward Jenner in 1798, who lived to witness its triumph over neglect, ridicule, and powerful opposition. The advantages over small-pox inoculation are its greater mildness and the avoidance of atmospheric infection. The vaccinated spot passes through the usual stages of the variolous eruption, and the scab falls from the fifteenth to the twenty-first day, leaving a peculiarly dotted scar. During the pustular stage there is a moderate fever, and the axillary glands are sometimes enlarged. As secondary attacks of small-pox occasionally take place, so many persons are susceptible to repeated vaccination after the lapse of years; and so, likewise, the protection against small-pox is often lost by neglect of vaccination. (See VACCINATION.)

The control of small-pox by vaccination is shown by the fact that this disease caused 96 deaths in 1000 in England from 1750 to 1800; from 1800 to 1850

the ratio was 35 in 1000, and has been much further reduced since vaccination became compulsory. In Germany, before vaccination was practised, the deaths from small-pox were 66.5 in 1000 from all causes, and after vaccination came in use, only 7.26. Among those partially protected by vaccination, and who still contract the disease, its severity is so mitigated that the average mortality is 5.24 per cent., while in the unvaccinated it is nearly 50 per cent.

CHICKEN-POX (*Varicella*).—This is a trivial contagious affection, from which children rarely escape in cities and towns, but to which adults are equally liable. An access of moderate fever is followed in a few hours by a vesicular eruption, which matures in 4 or 5 days and dries up with the formation of small scabs. Two or three crops of these vesicles may occur without an interval. The vesicles are easily broken, and often leave small depressions permanently in the skin.

The chief importance of this affection arises from the liability of confounding it with varioloid, or small-pox modified by previous vaccination. The points of distinction are as follows:

Varioloid.—Eruption appears on 3d day, and fever declines.

Eruption first papular, then vesicular, finally pustular.

Eruption most abundant on face and hands.

Fever violent.

Chicken pox.—Eruption and fever occur together.

Eruption vesicular throughout.

Eruption most abundant on trunk of body.

Fever moderate.

(s. s. H.)

SMET, PETER JOHN DE (1801–1873), Jesuit missionary to the Indians, was born at Dendermonde, Belgium, Dec. 31, 1801. He was educated at Mechlin, and in 1822 was sent to Maryland. In 1824 he was appointed a teacher in the University of St. Louis, and labored there until 1839. An embassy sent from the Flathead Indians about 1834 to ask for religious instruction had created a profound sensation. Father De Smet was then sent out and established missions both among the Flatheads in Oregon and among the Blackfeet on the Upper Missouri. To obtain assistance in the work and support he visited France and Belgium three or four times, and gave accounts of his work in English, French, and German. He was said to have more influence with the Indians of the Northwest than any other person. He died at St. Louis, May 23, 1873. His chief publications were *Letters and Sketches of a Residence in the Rocky Mountains* (1843); *Oregon Missions* (1847); *Western Missions* (1863); *New Indian Sketches* (1868).

SMELTING. See IRON.

SMILLIE, JAMES (1807–1885), engraver, was born in Edinburgh, Scotland, Nov. 23, 1807. He was apprenticed in 1819 to a silver engraver, and later worked with an engraver of pictures. His family came to Canada in 1821, and young Smillie worked there for some years. In 1827 he went to London, and after studying for five months under one Andrew Wilson in Edinburgh he returned to Quebec. He made his permanent residence in New York in 1830, and was there elected a National Academician in 1851. In 1874 he retired to Poughkeepsie, where he died, Dec. 4, 1885. The engraving after R. W. Weir's Convent Gate first drew attention to the young engraver, and it was followed by a series of plates, many after Weir's paintings, executed for the New York *Mirror* during 1832–36. Other important plates from his hand, all executed in the line manner, are *Dream of Areadia* (1850) and the *Voyage of Life* (1853–54), after Cole; *Dover Plains* (1850), after A. B. Durand; *Mount Washington* (1851), after Ken-aett; *American Harvesting* (1851), after Cropsey; and *Bierstadt's Rocky Mountains* (1865–66). After

1861 his time was devoted mainly to bank-note engraving, and he is regarded as the pioneer in that line. His artistic reputation, however, rests on his landscape work, and he probably had no equal here in that branch of engraving.

His son, **JAMES DAVID SMILLIE**, born in New York, Jan. 16, 1833, is well known both as engraver and painter. The best productions of his burin are perhaps the illustrations for Cooper's novels, after Darley's designs, although much of his work was on bank-note vignettes. In 1864 he turned his attention to painting, and has since then produced *The Diving of the Clouds*; *Dark against Day's Golden Death*; *Evening Among the Sierras*; *The Adirondacks*, *The Cliffs of Normandy*, and other important works. He became a member of the National Academy in 1876, was one of the original members of the Water Color Society, and one of the founders of the New York Etching Club. His brother, **GEORGE HENRY**, born in New York, Dec. 29, 1840, studied under his father and James M. Hart, and is well known as a painter. Among his works are *A Lake in the Woods*, *A Florida Lagoon*, *A Goat Pasture*, *Merrimack River*, and *Light and Shadow along Shore*, in oil, and *Under the Pines of the Yosemite*, *Near Portland, Maine*, and *September on the New England Coast*. He became a National Academician in 1882. (F. L. W.)

SMITH, CHARLES FERGOUSON, a distinguished soldier of the civil war, was born April 24, 1807, in Philadelphia, son of Dr. Samuel Blair Smith, assistant-surgeon in the U. S. army, his maternal grandfather (from whom he had his middle name) having been Ebenezer Ferguson, a colonel in the Revolutionary war. In 1825 he was graduated at the U. S. military academy and entered the service as 2d lieutenant in the 2d artillery, being promoted to 1st lieutenant, May, 1832, and captain in July, 1838. From 1829 to 1842 he filled several posts in the military academy—instructor of infantry tactics, adjutant, and commandant of the corps of cadets. In the Mexican war he served under Gen. Zachary Taylor with such distinction that the four companies of artillery he commanded became famous as "Smith's light battery," while he himself received, in rapid succession, the brevets of major, lieutenant-colonel, and colonel for "gallant and meritorious conduct" at Palo Alto, Resaca de la Palma, Monterey, Contreras, and Churubusco. He took part in the storming of Chapultepec and in the capture of the City of Mexico, and was again honorably mentioned. From 1849 to 1851 he was member of a board to devise a course of instruction for siege, garrison, sea-coast, and mountain artillery which was adopted, May, 1851. In 1854 he was promoted major of the 1st artillery, and in 1855 was appointed lieutenant-colonel of the 10th infantry. He commanded the Red River expedition in 1856, the Utah expedition in 1857–61, and was, for a time, in command of the Department of Utah. On the outbreak of disturbances preceding the civil war, he was appointed to the charge of the city and department of Washington. In August, 1861, he was promoted brigadier-general of volunteers and sent to Kentucky, where, next month, he became colonel of the 3d infantry, and took command of the forces at Paducah. His conduct at the capture of Forts Henry and Donelson acquired him the reputation of a skilful tactician as well as of a gallant soldier. In the fight for possession of Donelson he commanded the division holding the left of the investing lines, and led in person the assault that stormed the high ground commanding the fort. Of his exploit here Gen. W. T. Sherman says in his *Memoirs*: "Gen. C. F. Smith was a very handsome and soldierly man of great experience, and at the battle of Donelson had acted with so much personal bravery that to him many attributed the success of the assault." He

next conducted the new movement up the Tennessee River, and, arriving at Savannah with a considerable fleet in March, 1862, took command of the city and made ready the advance on Shiloh. On March 21 he was promoted major-general of volunteers, but chronic disease, contracted in Mexico, was so aggravated by the exposure to which he had been subjected that he died on April 25, 1862, at Savannah.

SMITH, EDMUND KIRBY, Confederate general, was born, May, 1824, in St. Augustine, Florida. On his graduation from West Point, in 1845, he was appointed 2d lieutenant of infantry, and in the Mexican war for gallantry at Cerro Gordo and Contreras was twice brevetted. From 1849 to 1852 he acted as assistant professor of mathematics at West Point. In 1855 he was appointed captain in the 2d cavalry, and served with distinction on the frontier, being wounded in May, 1859, in an engagement with the Comanche Indians, for his services against whom he received the thanks of the legislature of Texas in 1861. In January, 1861, he was promoted major, but on the secession of his native State in May of this year, he resigned his commission, and was appointed lieutenant-colonel in the cavalry corps of the Confederate army. His subsequent promotion was rapid. On June 17 he was made brigadier-general; on Oct. 11, major-general; on Oct. 9, 1862, lieutenant-general; and on Feb. 19, 1864, full general. He was present at the first battle of Bull Run, and was severely wounded early in the engagement. In 1862 he was assigned to the command of the Department of East Tennessee, Kentucky, North Georgia, and Western North Carolina. In the Kentucky campaign he led the advance of General Bragg's army, and, Aug. 30, 1862, defeated the Union forces under Gen. W. Nelson, at Richmond, Ky. Having been assigned in February, 1863, to the Trans-Mississippi Department (comprising Texas, Louisiana, Arkansas, and Indian Territory) he, in accordance with his instructions, organized a government there, making his communications with Richmond by running the blockade at Galveston and Wilmington, N. C. By a similar process of blockade-running he shipped large quantities of cotton to Europe, receiving back machinery, by the aid of which he was successful in establishing factories and furnaces, in opening mines, and in manufacturing powder and castings, so that by the time the war closed he had made his department self-supporting, his forces being the last to surrender. In 1864 he was largely instrumental in baffling Gen. Nathaniel P. Banks in his Red River campaign. Since the war Gen. Smith has been president of the Atlantic and Pacific Telegraph Company, chancellor of the University of Nashville, and, since 1875, professor of mathematics in the University of the South, Sewanee, Tenn., which last position he continues to hold.

SMITH, ELI (1801-1857), missionary, was born at Northfield, Conn., Sept. 15, 1801. He graduated at Yale College in 1821 and at Andover Seminary in 1826. He was immediately sent by the American Board as a missionary to Malta, but soon removed to Beyrout, Syria, which was the chief scene of his labors. His visit to the Nestorians of Persia in 1830 is related in his *Missionary Researches in Armenia* (1833). In 1838 and again in 1852 he was the companion of Rev. Edward Robinson (for whom, see *ENCYCLOPEDIA BRITANNICA*) in his journeys in Bible lands. The *Biblical Researches* which have established the fame of Robinson owe much of their accuracy to Dr. Smith's help. As a proper foundation for missionary work Dr. Smith exerted himself to establish at Beyrout an Arabic press, and for it he had cast at Leipsic, under his own supervision, an improved font of Arabic type. His great work of translating the Bible into modern Arabic was commenced in 1847, and within the remaining ten years

of his life he had completed the New Testament and the greater part of the Old. He died at Beyrout, Jan. 11, 1857. The Arabic translation of the Bible was finished by Rev. Dr. C. C. Van Dyke.

SMITH, ERASMUS PESHINE (1814-1882), jurist, was born in New York City, March 2, 1814, but at an early age was taken to Rochester. He graduated at Columbia College in 1832, and at the Harvard Law School a year later. He entered on practice at Rochester, but was also engaged in journalism until 1850, when he was appointed professor of mathematics in the University of Rochester. In 1852 he was made State superintendent of public instruction, and in 1857 reporter of the State court of appeals. In 1864 he was called to Washington to be U. S. commissioner of immigration, but soon was appointed examiner of claims in the Department of State. In 1871 Secretary Hamilton Fish, having been asked by the Mikado of Japan for an adviser in international law, selected Prof. Smith. The latter spent five years in Japan in preparing treaties and directing the foreign relations of that empire. During this time a Peruvian ship with a cargo of 230 Chinese coolies was wrecked on the coast of Japan, and that government, by the advice of Prof. Smith, detained them until the question of their destination was settled by the arbitration of the Russian government. The coolies by its decision were sent back to China, and this affair broke up the coolie trade. Prof. Smith returned to Rochester in 1876 and died there, Oct. 21, 1882. His chief publication was a *Manual of Political Economy* (1853), in which he advocates protection.

SMITH, GERRIT (1797-1874), philanthropist, was born at Utica, N. Y., March 6, 1797. His father, Peter Smith, had been associated with John Jacob Astor in the fur trade, and had purchased vast tracts of land in northern New York. Gerrit, after graduating at Madison College in 1818, settled at Peterboro, and devoted himself to the management of his estate. In 1825 he joined the American Colonization Society and contributed liberally to its funds until he became convinced of its inefficiency as an aid to the colored people. In 1835 he turned to the Anti-Slavery Society and became prominent in its work. He gave away to actual settlers, whether white or black, small farms from his estate, and thus gathered around him a thrifless lot. In 1852 he was elected to Congress, but served only one session. To every assault on the slavery system he was a willing contributor, and hence gave aid to the Free Soil settlers in Kansas and to John Brown's project in Virginia in 1859. The war for the Union enlisted his sympathies and active support, but at its close he was in favor of universal amnesty. Originally trained in orthodox belief, he became a Universalist and extreme rationalist. He wrote and spoke against revealed religion, yet in the church he had built at Peterboro he frequently preached. He died at New York City, Dec. 28, 1874.

SMITH, GOLDWIN, an English historical and political writer, was born at Reading, Berkshire, Aug. 13, 1823. He was educated at Eton and Magdalen College, Oxford, graduating with high honor in 1845. He was chosen fellow and tutor of University College, and in 1847 was called to the bar at Lincoln's Inn. In 1850, and again in 1854, he was secretary of a Royal commission of University reform, and from 1858 to 1866 he was a member of the Education commission, whose labors resulted in the Education bill of 1870. He was also appointed regius professor of modern history at Oxford in 1859, and held this position till 1866. He had always been an advanced Liberal in politics, and during the American civil war was conspicuous for his defence of the Union. Among his publications of this time are *The Foundation of the American Colonies* (1861); *The Morality of the Emancipation Proclamation* (1863). In 1864 he

visited the Northern States on a lecturing tour, and on his return published *England and America* (1865) and *Civil War in America* (1866). He was called in 1868 to Cornell University to be professor of English history, but in 1871 he settled at Toronto, Canada, where he became a member of the senate of the university. He edited the *Canadian Monthly* until 1874, and then became editor of the *Bystander*, a political weekly. After this was discontinued he was editor of *The Week*, but in 1887 he finally separated from it. In that year he returned to England, where he has continued his literary activity, discussing public questions affecting England, Ireland, Canada, and the United States. Besides his works already mentioned he has published *Irish History and Irish Character* (1861); *Three English Statesmen*, sketches of Pym, Cromwell, and Pitt (1867), *Short History of England* (1863); *William Coucher in the English Men of Letters* (1880); *Conduct of England to Ireland* (1882).

SMITH, HENRY BOYNTON (1815-1877), Presbyterian theologian, was born at Portland, Maine, Nov. 21, 1815. He graduated at Bowdoin College in 1834, and studied theology at Andover and Bangor. After some time spent in study at the Universities of Halle and Berlin, he was in 1841 acting president of Bowdoin. In 1842 he became pastor of the Congregational Church at West Amesbury, Mass., and in 1847 he was made professor of moral and mental philosophy in Amherst College. In 1850 he was called to the professorship of church history in Union Theological Seminary, New York, and in 1854 he became professor of systematic theology. After holding this position twenty years he resigned on account of ill-health, and died, Feb. 7, 1877. He was a promoter of the Evangelical Alliance and of the reunion of the Presbyterian Churches. He had belonged to the New School branch, and as moderator of its General Assembly in 1863 he welcomed the first delegation from the Old School body. He was one of the editors of the *New York Evangelist* and of the *American Theological Review*, which afterward became the *Presbyterian Review*. He translated and edited Gieseler's *Church History* and Hagenbach's *History of Doctrines*. From his writings have been collected volumes, published posthumously, on *Faith and Philosophy*, *Apologetics*, and *Introduction to Theology*.

SMITH, JOHN LAWRENCE (1818-1883), chemist, was born near Charleston, S. C., Dec. 17, 1818. He was educated at Charleston College and the University of Virginia, and became a civil engineer. After some service on the Charleston and Cincinnati Railroad, he studied medicine and graduated at the Medical School of the University of South Carolina. After three years' further study in France and Germany, he began practice at Charleston in 1844. Two years later James Buchanan, then U. S. Secretary of State, was requested by the Sultan of Turkey to recommend some person for the purpose of instructing the people of that empire in the cultivation of cotton. Dr. Smith was selected and went to Turkey, but the original purpose of his mission was not carried out. He was made mining engineer to the Turkish government, and spent four years in examining the mineral resources of the empire. One result was his publication on the *Thermal Waters of Asia Minor* (1849). Returning to the United States, Dr. Smith discovered emery and corundum in North Carolina. He completed his invention of the inverted microscope, which he had commenced in Paris in 1850. He was appointed professor of chemistry in the University of Virginia, but, having married the daughter of James Guthrie, U. S. Secretary of the Treasury, removed to Louisville, Ky., where he became professor of chemistry in the Medical School. He was afterward superintendent of the

Louisville gas-works. In 1867 he was U. S. Commissioner to the Paris Exposition, and in 1873 to that of Vienna, and in connection with these prepared valuable reports on industrial chemistry. In 1876 he was one of the judges at the Centennial Exhibition at Philadelphia, and wrote the report on *Petroleum*. In 1874 he had been chosen president of the American Association for the Advancement of Science. He had the best collection of meteorites in the United States, having purchased that of Dr. Gerard Troost (*q. v.*), and greatly enlarged it. This collection is now in possession of Harvard University. Dr. Smith was active in religious and philanthropic movements. He endowed the Baptist Home at Louisville. He died, Oct. 12, 1883. He had published more than 70 scientific papers, and many of these were gathered in his *Mineralogy and Chemistry, Original Researches* (1873), of which an enlarged edition, with biographic sketch, was issued after his death.

SMITH, PERSIFOR FRASER (1798-1858), general, was born in Philadelphia in November, 1798, both his grandfathers having served with honor in the war of the Revolution. After graduating at Princeton in 1815, he studied law in Philadelphia and, on his admission to the bar, removed to New Orleans. His passion was, however, for arms, and at the outbreak of the Seminole war, being adjutant-general of Louisiana, he raised some regiments of volunteers, marched to the scene, and there conducted himself so as to attract the special attention of Generals Gaines, Scott, and Taylor, and insure their lasting confidence. On the conclusion of this war he returned to his judicial functions in New Orleans, but in the spring of 1846, hearing of Gen. Taylor's straits on the Rio Grande, he again raised a body of volunteers and hastened to his assistance, remaining in command of a brigade till the close of the war with Mexico. He distinguished himself especially in the fierce battle of Monterey, for which he was brevetted brigadier-general in the U. S. Army. Gen. Smith then joined the army under Gen. Winfield Scott, and his conduct at the battle of Contreras elicited the warmest praise of that commander. For his services here, and at the immediately subsequent battle of Churubusco, he was brevetted major-general, Aug. 20, 1847. On the resumption of hostilities, after an intervening armistice (for which he was a commissioner), he participated in the affair of Chapultepec and was in active service at the capture of the city of Mexico. At the conclusion of the war he was ordered to California, where he held command of the Military Department, and afterward held a similar command in Texas. In December, 1856, he was appointed to the full rank of brigadier-general and ordered to Kansas. In April, 1858, he was assigned to the command of the Department of Utah. This he held only for a month, dying at Fort Leavenworth, Kansas, whither he had gone for his health, May 17, 1858.

SMITH, SAMUEL (1752-1839), general and statesman, was born at Lancaster, Pa., July 27, 1752. His father, born in Ulster, became a successful merchant in Baltimore, took part in the patriotic movements at the outbreak of the Revolution, was a delegate to the Maryland constitutional convention in 1776, and afterward State senator. Samuel, after a business-training in his father's counting-room, went to Europe in 1772, and travelled extensively. Returning in 1775, he became a captain in a regiment of the Maryland line, fought in Long Island, and at White Plains, where he was wounded. In 1777 he was promoted to be major, and fought at Brandywine. Ordered by Washington to Fort Mifflin, near Philadelphia, he sustained a siege by the British from Sept. 26 to Nov. 11, and then, being wounded, retired to New Jersey. For his defence Congress

gave him a vote of thanks and a sword. He was afterward at Valley Forge and Monmouth, then resigned his commission, though acting as colonel of militia at Baltimore. In 1783 he was made a port warden there and in 1790 was elected to the legislature. He commanded the quota of Maryland troops called out to suppress the Whiskey insurrection in Pennsylvania. For ten years from 1793 he was a representative in Congress, serving also for a short time in 1801 as secretary of the navy. In 1803 he was elected to the U. S. senate, and was one of the prominent supporters of Jefferson's policy. He was major-general of the Maryland troops in defence of Baltimore in 1814. He was active in promoting the interests of Baltimore, helping to found the Bank of Maryland in 1790, to establish a library, and to adorn the city with the monuments which long gave it the name "Monumental City." At the age of 83, long after he had retired from public work, he was called to suppress a mob, and did the work so effectively that he was elected mayor and served for three years. He died at Baltimore, April 23, 1839.

His brother, ROBERT SMITH (1757-1842), also born at Lancaster, graduated at Princeton College in 1781, studied law, and practised at Baltimore. He served in many public capacities, was a presidential elector in 1789, state senator in 1793, delegate, 1796-1800, and member of the city council, 1793-1801. Pres. Jefferson made him secretary of the navy from January, 1802, till 1805, and U. S. attorney-general from March till December, 1805. He was appointed chancellor of Maryland soon afterward, and Pres. Madison called him into his cabinet as secretary of state in March, 1803, but in November, 1811, when the faction clamorous for war with Great Britain gained the upper hand, Smith retired, though Madison offered him the embassy to Russia. In 1813 he was made provost of the University of Maryland, and he held other posts of honor. He died at Baltimore, Nov. 26, 1842.

SMITH, SAMUEL FRANCIS, minister and hymn-writer, was born at Boston, Oct. 21, 1803. Graduating at Harvard in the famous class of 1829 with Dr. O. W. Holmes, Rev. James Freeman Clarke, and others of note, he studied theology at Andover, and in 1831 became pastor of a Baptist church at Waterville, Maine. Before this he had written for the press, had translated for Dr. Lieber's *Encyclopædia Americana*, and had edited the *Baptist Missionary Magazine*. In 1842 he removed to Newton, Mass., where besides pastoral work he conducted the *Christian Review* for seven years. Religious and secular journals and magazines welcomed his contributions. His national hymn "America," "My country, 'tis of thee," was written at Andover in 1832 and first sung publicly in Park Street Church, Boston, July 4, 1832. Another of his hymns is "The morning light is breaking." In 1855 he became editor of the periodicals of the Baptist Missionary Union. He contributed to Sprague's *Annals of the American Pulpit*, and to the *Baptist Jubilee*. The *Psalmist*, a standard Baptist hymn-book, contains 27 of his hymns. Among his later publications are *Missionary Sketches* (1879); a *History of Newton, Mass.* (1880); and *Rambles in Mission Fields* (1884).

SMITH, SAMUEL STANHOPE (1750-1819), educator, was born at Pequea, Pa., March 16, 1750. His father, Dr. Robert Smith, had emigrated from Ulster, and settled in Pennsylvania as pastor of a Presbyterian church, conducting also a classical academy, which became famous. The son studied in it, and, after graduating at Princeton College in 1769, returned to teach. But he was soon called to be a tutor at Princeton, and was ordained to the Presbyterian ministry in 1774. He went to Virginia, and in 1775 became the first president of Hampden-Sidney College. In 1779 Samuel was called to be

professor of moral philosophy at Princeton, and in 1783 he was made professor of theology. In 1786 he became vice-president, and finally, in 1795, president, of the college, retaining this position till 1812. (See NEW JERSEY, COLLEGE OF.) In the Presbyterian Church he was almost equally influential with his predecessor, Rev. Dr. John Witherspoon (*q. v.*) whose daughter he had married. In the organization of that church, in 1786, he took part in drafting its form of government. Dr. Smith was noted for his dignity, courtly manners, and eloquence—trained on the French models. He died at Princeton, Aug. 21, 1812. Besides separate sermons, he had published a volume in 1798, and after his death two more volumes appeared with a memoir. He had also published *Lectures on the Evidences of the Christian Religion and on Moral Philosophy* (1809), a *System of Natural and Revealed Religion* (1816), and had brought down to a later date the *History of the United States* by his brother-in-law, Dr. David Ramsay.

His brother, JOHN BLAIR SMITH (1756-1799), also a Presbyterian minister and educator, was born at Pequea, Pa., June 12, 1756. He graduated at Princeton College in 1773, and studied theology with his brother, then president of Hampden-Sidney College, and succeeded him in this position in 1779. Also gifted with eloquence, he became a noted revival preacher in the Valley of Virginia. In 1791 he was called to the Third Presbyterian Church, Philadelphia, and after four years' service was made president of Union College, Schenectady, N. Y.; but in May, 1799, he was induced to return to his former charge in Philadelphia. This later service was cut short by his death on Aug. 22, 1799.

SMITH, SERA (1792-1868), best known under the name "Major Jack Downing," was born at Buckfield, Maine, Sept. 14, 1792. He graduated at Bowdoin College in 1818, and became a journalist at Portland. His humorous political letters, satirizing President Jackson, were in 1833 collected in a volume which passed through many editions. A later work of a similar character was his *Thirty Years out of the Senate* (1859). Smith also published several poems, the longest of which was *Poohatum* (1841), and a volume of sketches called *Down East* (1855). He died at Patchogue, L. I., July 29, 1868. He had married Elizabeth Oakes Prince, who contributed many poems to periodicals, at first anonymously, but openly after her husband had become embarrassed in business. Her first collection was called *The Sinless Child and other Poems* (1843). Then came tragedies, *The Roman Tribute* and *Jacob Leister, or Old New York*, and, after a long interval, *Destiny*. Meantime she had published several novels and tales and some works on woman's rights. After her husband's death she resided for many years in New York City, but afterward in North Carolina.

SMITH, WILLIAM (1726-1803), the first provost of the University of Pennsylvania, was born in Aberdeen, Scotland, in 1726. After graduating at the university of that city, in 1747 he emigrated to America and became tutor in the family of Col. Martin, on Long Island. He was called by Franklin and others to Philadelphia to take charge of the projected college. His *General Idea of the College of Mirania* gave his view of what was to be aimed at in the new institution. To obtain help for it and to receive episcopal orders he visited England in 1753. The academy which was opened in that year became in 1754 the College of Philadelphia. His loyal adherence to the Penn family provoked political controversies, and at one time he was thrown into prison, where his classes came for instruction. On his second visit to England, in 1759, the University of Oxford conferred on him the degree of D. D., and on a third, in 1762, he collected for his college £6,000. He took the patriotic side in the crisis of the revolu-

tion, and his oratorical powers were enlisted in favor of Congress. Yet at the close of the war a factious opposition was made against him, and the legislature chartered the University of Pennsylvania to supersede the college. Smith resisted, and in 1789 was again recognized as provost of the college. In 1791 a compromise was effected, the college was merged in the university, but Dr. Smith retired from office. He died at Philadelphia, May 14, 1803. His publications comprise various sermons and orations, some political tracts, and a history of *Bouquet's Expedition against the Western Indians*. A selection of these was published in 1803.

His grandson, RICHARD PENN SMITH (1799-1854), obtained some note as a dramatist. He was born in March, 1799, and admitted to the Philadelphia bar in 1821. He edited the *Aurora* for the next six years and then wrote for Edwin Forrest two tragedies, *Caius Marius* and *The Venetian*. Besides other successful plays, he wrote some novels and a *Life of David Crockett* (1836). He died, Aug. 12, 1854. His son, Horace Wemyss Smith, born in 1825, has edited his *Works*, written a *Life of William Smith* (4 vols.), and compiled *Patriotic Songs of America*.

Another grandson, William Endolph Smith (1787-1868), went to Wisconsin in 1837, and became attorney-general of that State in 1853. He was also president of its Historical Society and published *History of Wisconsin* (4 vols., 1854).

SMITH, WILLIAM, has been highly successful in uniting the labors of scholars in his dictionaries of biblical, classical, and early Christian literature. He was born in London in 1813, and graduated at its university, being a layman and originally a Dissenter, though he afterward entered the Church of England. From 1853 to 1869 he was classical examiner for London University, and afterward a member of its senate. Since 1867 he has been editor of the *Quarterly Review*. His chief Dictionaries are those of *Greek and Roman Antiquities* (1840-42); *Greek and Roman Biography* (1843-49); *Dictionary of the Bible* (3 vols., 1860-63), the American edition being enlarged and improved by Profs. H. B. Hackett and E. Abbot (4 vols., 1869-70); *Christian Antiquities* (2 vols., 1875-80), in which Prof. Cheetham assisted; and *Christian Biography* (4 vols., 1877-86), in which Dr. Henry Wace assisted. The last two works come down only to the age of Charlemagne. Dr. Smith's son Philip has been associated with him in the preparation of the numerous works of reference above mentioned, and has published a *History of the World*.

SMITH, WILLIAM FARRAN, a general of the civil war, and known in the army as "Baldy" Smith, was born in St. Albans, Vt., Feb. 17, 1824. He graduated at West Point in 1845, was made brevet 2d lieutenant of topographical engineers, and, after a year's service in this department, became assistant-professor of mathematics at West Point, which post he filled for two years. His next service was in Texas for the Mexican boundary commission and in Florida till, in 1855, he was reinstated in his former office at West Point, being then 1st lieutenant. In 1856 he was assigned to light-house construction service, and in 1859 was made engineer-secretary of the Light-house board. In June and July, 1861, he served on the staff of Gen. B. F. Butler at Fortress Monroe, and then became colonel of the 3d Vermont Volunteers. He was engaged in the first battle of Bull Run on the staff of Gen. McDowell. Commissioned, Aug. 13, brigadier-general of volunteers, he continued to serve on the defences of Washington till March, 1862. In McClellan's Peninsular campaign he was brevetted lieutenant-colonel in the regular army for gallant and meritorious service at the battle of White Oak Swamp, and

had taken part also in the siege of Yorktown, and the battles of Williamsburg, Fair Oaks, Savage Station, Glendale, and Malvern Hill. In July, 1862, he was advanced to major-general of volunteers, but this promotion was not confirmed by the Senate. In the Maryland campaign he led his division in the battles of South Mountain and Antietam, receiving the brevet of colonel in the regular army for the latter engagement. In November, 1862, he was assigned to the command of the Sixth Corps and took part in the battle of Fredericksburg. In February, 1863, he was transferred to the Ninth Corps and, on March 3, became major in the Corps of Engineers. In June and July, 1863, he commanded a division of the Department of the Susquehanna; in October, became chief engineer of the Department of the Cumberland, and, in November, of the military division of the Mississippi. In October he directed the throwing of a pontoon-bridge over the Tennessee at Brown's Ferry, below Chattanooga, and the capture of the heights above it, and participated in the battle of Missionary Ridge. Of his services here Gen. George H. Thomas, in his report, says: "To Brig.-Gen. W. F. Smith should be accorded great praise for the ingenuity which conceived and the ability which executed the movement at Brown's Ferry. When the bridge was thrown at Brown's Ferry, on the morning of the 27th Oct., 1863, the surprise was as great to the army within Chattanooga as it was to the army besieging it from without." In April, 1865, the House committee on military affairs unanimously agreed to a report that, "as a subordinate, Gen. William F. Smith had saved the army of the Cumberland from capture, and afterward directed it to victory." In March, 1864, his rank as major-general of volunteers was confirmed, and in May he was placed in command of the Eighteenth Corps, which he led at Cold Harbor and at Petersburg till July, when he was assigned to special duty. On March 13, 1865, he was brevetted brigadier-general of the U. S. army for his services at the battle of Chattanooga, and major-general for services in the field during the war. In November, 1865, he resigned his volunteer commission, and, in 1867, that in the U. S. army. In 1865 he became president of the International Telegraph Company; in 1875, police-commissioner of New York City, and soon thereafter was chosen president of the board. Since 1881 he has practised as a civil engineer.

SMITH, WILLIAM ROBERTSON, British theologian, was born at Keig, Scotland, Nov. 8, 1846. He graduated at Aberdeen University in 1865, and studied also at the Universities of Bonn and Göttingen. In 1868 he began to teach physics at Edinburgh, but he was already noted for his acquaintance with Oriental languages, and in 1870 was made professor of Hebrew in the Free Church College at Aberdeen. His course of instruction roused some opposition by its rationalistic tendency, and this was brought to a height on the publication of his article on the Bible in the *ENCYCLOPEDIA BRITANNICA*. A series of trials in the Church courts for heresy ensued and, though he was not convicted, he was suspended from teaching, and finally removed from his professorship in 1881. The controversy had not prevented his contributing other articles of a similar kind, and he now became associate editor of the *BRITANNICA*. In 1883 he was made Lord Almoner's professor of Arabic in Cambridge University, and in 1886 librarian to that university. His separate publications are *The Old Testament in the Jewish Church* (1881); *The Prophets of Israel* (1882); and *Kinship and Marriage in Early Arabia* (1885).

SMITH COLLEGE, an institution for the higher education of women, was founded by Miss Sophia Smith, of Hatfield, Mass., who bequeathed the bulk of her property for that purpose; stated the char-

acter of the education which should be given; appointed the first trustees; and selected Northampton as its site. The market value of the funds which the college received from the estate of Miss Smith after her death, June 12, 1870, was estimated at \$387,468. To this sum the town of Northampton added \$25,000, to comply with a condition of her will concerning the site.

The college was incorporated by the Commonwealth of Massachusetts, March 3, 1871, and a charter was granted empowering it: "To grant such honorary testimonials, and confer such honors, degrees, and diplomas as are granted or conferred by any university in the United States. The trustees held their first meeting at Northampton, April 12, 1871, when the Board was organized. The same year 13 acres in the centre of the town were purchased as a site; but it was decided not to build until the funds could accumulate and a president be obtained. A circular issued by the trustees, Sept. 10, 1872, stated: "It is the design of the trustees, as it was evidently of the founder, not to add to the number of such schools, seminaries, or academies, as now exist for young ladies, but to realize completely and truly the idea of a *Woman's College*. They would secure to young women a culture fully equivalent to that afforded to young men by our best New England colleges, and yet differing from that as woman differs from man in her physical and mental constitution, and in the sphere of her active life. The requirements for admission will be substantially the same as at Harvard, Yale, Brown, Amherst, and other New England colleges."

Rev. L. Clark Seelye, D. D., was elected president of the college, June 17, 1873, while professor of rhetoric and English literature at Amherst College. He entered immediately upon the duties of his office, and under his direction the first academic building was erected, and formally dedicated, July 14, 1875. The college was opened for the reception of students the second Thursday in September, 1875. Those only were received who were able to meet the same requirements in Greek, Latin, Mathematics, and English, which were demanded in the New England colleges for young men. There was no preparatory department. A four years' course of study was adopted, corresponding in extent and thoroughness with the collegiate courses in the leading American colleges. The trustees decided to receive at the opening only those who were qualified to enter the First Class, and to add each year a new class and the requisite teachers, until the four classes and the Faculty were formed. Sixteen were admitted to the First Class and eleven teachers were provided for them. There were no commencement exercises until June 18, 1879, when eleven graduates received the degree of A. B.

A distinctive feature of the college was the adoption of the plan of comparatively small dwelling-houses, entirely distinct from the academic buildings, and arranged as far as possible like private houses. Each was to be presided over by a lady who should act as the "house mother," and whose special duty it should be to direct its social and domestic life. Students were permitted to choose between residence in these college homes or families in the town which were approved by the Faculty. One dwelling-house was provided at the opening of the college, and others were afterward erected to meet the wants of successive classes. These dwelling-houses are separate establishments; each has its own kitchen, dining-room, parlors, and bedrooms, and each is located apart so as to lessen the danger from fire, and to give free access of light and air to the other buildings. The largest will accommodate fifty students, and the smallest twenty-one; and the present policy is to provide accommodations for no

larger number in any single house. The plan of these dwelling-houses is the natural outgrowth of the design of the college, as expressed in its official circulars: "It is a *Woman's College*, aiming not only to give the broadest and highest intellectual culture, but also to preserve and perfect every characteristic of a complete womanhood."

The physical culture of the students is provided for by a gymnasium, and by a specialist in that department, who prescribes, after personal examination, exercises adapted to the individual need. In its religious character the college is Christian in its aims, but undenominational in management and instruction. There is no college church, and students are expected to attend churches in the city, according to individual preference.

For some years Smith College gave academic degrees only to those who completed the usual collegiate classical course, but in 1886 two additional courses of study were arranged, called the Literary and Scientific. These also extend through four years, and graduates from the Literary course receive the degree of Bachelor of Literature; from the Scientific course, the degree of Bachelor of Science; while graduates from the classical course continue to receive the degree of Bachelor of Arts. The distinctive peculiarity of these courses in Literature and Science is the requirement of a greater amount of modern languages or of the natural sciences, in place of the classics or mathematics. The design of all the various courses is thus stated: "The college is not intended to fit woman for a particular sphere or profession, but to perfect her intellect by the best methods which philosophy and experience suggest, so that she may be better qualified to enjoy and to do well her work in life, whatever that work may be."

In 1880 a school of music and a school of art were established in connection with the college, for the purpose of providing the best facilities for the study of Music, practical and theoretical, and of Drawing, Painting, and Sculpture; and the following year a Music Hall and Art Gallery were erected for their accommodation. These schools have separate corps of teachers, and regular courses of study extending through four years. Members of the academic department can take a part of any of these courses as electives, and students of approved age and attainments can pursue them exclusively as specialties. Post-graduate courses are provided for those who wish to pursue advanced studies in Music, Art, Philosophy, Language, Literature, and Science.

Additional gifts have been made to the college. The most important of these are: \$30,000 for an Art Gallery, and \$50,000 for an Art Fund, by Mr. Winthrop Hillyer; \$50,000 as a bequest from Mr. George W. Hubbard; \$32,500 for the Lilly Hall of Science, by Mr. A. T. Lilly; \$20,000 to purchase works of art; \$15,000 for an Observatory; 10,000 for additional studios to the Art Gallery; \$12,000 for scholarships; and \$5,000 as a bequest from Gov. W. B. Washburn. From its general fund the college gives annual scholarships of \$100 to all deserving students who are unable to complete a collegiate education without such aid. The present value of the college funds is \$469,283, and of its real estate, \$400,000.

Since the opening of the college the number of students has steadily increased, and in 1888 it was 435. The various classes number as follows: First Class, 155; Second Class, 98; Junior Class, 60; Senior Class, 48; Music School, 37; Art School, 31; Resident Graduates, 6. The Faculty, aside from lecturers and non-resident teachers, numbers 23, and includes both sexes in about equal proportions. Miss Smith in her will appointed only men as trustees, but in June, 1888, the trustees requested the associate ~~alumnæ~~ of the college to nominate three candidates

to fill existing vacancies in the Board, and that request will doubtless be complied with. (U. C. S.)

SMITHSONIAN INSTITUTION. This highly important American scientific institution has been already partly considered under **ACADEMIES OF SCIENCE (q. v.)**. It was founded in accordance with the terms of a bequest made by James Smithson, of England, of whose life and services to science we may fitly here give a brief résumé. He was born about 1765, being a natural son of James Smithson, first duke of Northumberland, by Elizabeth Macie, and long bore the name of James Lewis Macie, adopting that of Smithson somewhere between 1791 and 1803. He studied at Oxford, and graduated from Pembroke College in 1786, becoming a Fellow of the Royal Society the next year. He devoted himself to the study of science, particularly of chemistry, and became an associate and friend of Sir Humphry Davy, Sir Joseph Banks, and Dr. Wollaston. The results of his scientific observations were published in *Philosophical Transactions*, *Annals of Philosophy*, and other scientific periodicals, and included treatises "On the Composition and Crystallization of certain Sulphurets from Huel Boys in Cornwall," "Facts Relating to the Coloring Matter of Vegetables," etc. He died at Genoa, Italy, on June 27, 1829, leaving by will the whole of his property to the United States, for the purpose of founding at Washington an institution, to be known under his name, "for the increase and diffusion of knowledge among men."

This bequest, amounting to more than \$500,000, was one of the first of those far-seeing gifts to mankind which have been of such great service to the progress of human knowledge, and the example of which is now being somewhat frequently followed. The bequest was accepted by Congress, June 1, 1836, and was placed under interest immediately on reaching the treasury, Sept. 1, 1838. It is now invested in the 6 per cent. gold interest bonds of the United States, and has been managed so skillfully and economically that the building has been erected solely from the interest, while the residue over that used for this and other purposes has been added to the principal until this has increased nearly \$200,000. The ultimate limit of the principal sum has been fixed by law at \$1,000,000.

The Smithsonian Institution was established by act of Congress, Aug. 10, 1846. It was to be administered by a Board of Regents, composed of the Chief Justice of the Supreme Court, three Senators appointed by the Vice-President, three Representatives chosen by the Speaker of the House, and six citizens chosen by Congress. The Representatives were to serve 2 years, the Senators for term of office, the citizens for 6 years, the services of all to be gratuitous. This Board meets annually in January, and receives and transmits to Congress the report of its Secretary, who is also Secretary of the Institution. In addition to the Board of Regents, the President, Vice-President, Cabinet Officers, and such honorary members as they may elect are by law constituted an "establishment," or board of visitors, which is entitled the Smithsonian Institution. The Regents and the honorary members of the "establishment" hitherto chosen have been men of eminence and uprightness as statesmen, the citizen members from the several states being selected for their high character and position, and literary or scientific reputation.

The building which has been erected for the purposes of the Smithsonian Institution is an imposing edifice, of the order of architecture known as Norman, or Romanesque. Its material is a red sandstone from the quarries of Seneca Creek, near Washington, the stone being rather soft when quarried, but hardening and developing great resisting qualities when

exposed to the atmosphere. The edifice consists of a main central building of two stories, with two wings connected by intermediate ranges. The dimensions of the main building are 205 by 57 feet and 58 feet high, with two towers in the centre of the principal front, the higher of which is 140 feet in elevation. On the south front is a massive tower 37 feet high, and the building in all possesses 9 towers. The entire length is 447 feet, and the greatest breadth 160. The first story of the main building is one large room, 200 by 50 feet in dimensions and 25 feet high, with a row of columns down the centre. The second story has a room of equal area without supporting columns.

The corner-stone of this edifice was laid, May 1, 1847, with Masonic ceremonies, in the presence of Pres. Polk and his cabinet, the oration being delivered by the Vice-President, George M. Dallas. On Jan. 4, 1865, it took fire from a defective flue and was partly destroyed, the west end and part of the centre being burned. Much valuable material was destroyed by this fire, among it the Stanley gallery of Indian paintings, an irreparable loss. Its only counterpart is the Catlin gallery, now in the care of the Institution. The building has been slowly restored from the income, without detriment to the scientific work of the Institution, and is now a fire-proof structure, situated in the park reservation and thus removed from all danger of conflagration.

By law the Smithsonian Institution is the depository of the United States National Museum, which was at first partly supported by its funds, but is now sustained at the sole expense of the government. This museum, beginning with the scientific material collected by the Wilkes exploring expedition, and designed to contain "all objects of art and of foreign and curious research, and all objects of natural history, plants, and geological and mineralogical species belonging or hereafter to belong to the United States," has greatly augmented, and become so rich in many departments that the building of the Institution is quite insufficient to contain it, and an adjoining edifice of very extensive floor-space has been erected for that purpose. The Smithsonian building now contains only natural history and other strictly scientific material, while much of this, together with a vast accumulation of objects of human art, has been removed to the new edifice. The art collections are now deposited in the Corcoran Gallery, while the library, of 75,000 volumes, has been added to the Library of Congress, and forms the National Science section of that library.

In this way the extraordinarily large collection of materials made within forty years has been disposed of, and the Institution left to its legitimate functions of "the increase and diffusion of knowledge among men." In the furtherance of this purpose, the Institution has from time to time taken upon itself functions from which it has been since relieved by act of Congress. Thus for a number of years it conducted a series of meteorological observations, and began that systematic study of the weather which is now performed by the Weather Bureau of the government. In like manner, its herbarium and entomological collection has been transferred to the Department of Agriculture, which now conducts the important study of insect-ravages upon agriculture. Thus one by one departments of study adopted by the Institution have been removed from it, and its income is now used for strictly scientific purposes, without special regard to economic considerations. It is, in fact, now restricted to its original purpose of "the increase and diffusion of knowledge," the first being achieved by scientific study of the material which is constantly flowing in from government and private exploring parties in all parts of the country; the second, by its useful work of receiving

and distributing to learned bodies and individuals at home the publications of similar bodies and individuals abroad, and by the highly valuable publications which it issues from time to time.

The publications of the Institution comprise three series, the first and most important being *Smithsonian Contributions to Knowledge*, embracing records of original investigation which have resulted in what appear to be new truths and constitute positive additions to the sum of human knowledge. Of this series 25 volumes have been issued. Second, *Smithsonian Miscellaneous Collections*, containing reports of the state of knowledge in particular branches of science, lists and synopses of species, reports of explorations, instructions for collecting, etc. This series now numbers 33 volumes. Third, *Annual Report of the Smithsonian Institution*, in which, in addition to the business report, interesting foreign and American scientific treatises have been published, and of late years an annual report of the general progress of science in all its branches. The publications of the National Museum, of the Bureau of Ethnology, and of the Philosophical Society of Washington are also published under the auspices of the Institution, while with its work has of late years been associated the scientific observations of the United States Fish Commission, which is now under the control of the Secretary of the Institution, and much of whose studies in development, artificial fertilization, etc., has been done within its walls. The vast mass of material, indeed, which has steadily poured in from every direction and many sources, has proved beyond the ability of the scientific corps of the Institution to handle, and much of it remains in an inchoate condition, the more perishable portion slowly becoming useless for want of prompt handling. This is a state of affairs for which the governing powers of the Institution are not responsible, but which sadly needs remedy, either by a decided increase of the scientific corps, or a check to the inflow of material until that now accumulated can be studied and disposed of. Scientific material which cannot be promptly handled world, as a rule, be far better left to its natural habitat and condition.

The Smithsonian Institution has, almost since its inception, been under the control of two of our prominent scientists, men remarkably well adapted to develop the important interests committed to their care. The first Secretary, elected at the foundation of the Institution in 1846, was Prof. Joseph Henry, the eminent electrician, than whom no man stands higher in the ranks of American scientists. Prof. Henry was strictly conservative in his direction of the important trust confided to him, and aimed rather to diffuse knowledge and stimulate research than to make large collections of material. In 1850 Spencer F. Baird was elected Assistant Secretary, and to him was committed the control of the National Museum, which Prof. Henry had regarded rather as a departure from the original design of the Institution. Prof. Baird took active measures to develop the museum by enlisting in the service the leaders of government explorations, providing them with materials and instructions, and organizing natural history parties in connection with all important expeditions. His annual report constitutes the only systematic record of the national explorations ever prepared. In 1871 Prof. Baird was appointed Commissioner of Fish and Fisheries, and in May, 1878, on the death of Prof. Henry, was made full Secretary of the Institution. He died, August 19, 1887, and has been succeeded in the Secretaryship by Prof. Samuel P. Langley, the eminent astronomer, recently director of the observatory at Allegheny City, Pa. George Brown Goode, who has for years been employed in the National Museum, has been appointed Assistant Secretary, the management of the

National Museum being placed in his hands. There is every reason to believe that the Smithsonian Institution, under this new management, with the experience and material gained during its former history, and its release from functions not directly in its designed line of work, will rapidly advance in usefulness and assume a position in the world of science on a level with that of the best equipped scientific institutions of foreign lands. (C. M.)

SMYTH, CHARLES PIAZZI, English astronomer, was born Jan. 3, 1819, being son of Admiral William Henry Smyth, and grandson of J. B. Palmer Smyth, of New Jersey, a loyalist in the American Revolution. W. H. Smyth (1788–1865) entered the British navy in 1805, and, after honorable service in the wars of Napoleon's time, was appointed to make a hydrographical survey of the coasts of Sicily, afterward of the Adriatic, and finally of the entire Mediterranean. He became rear-admiral in 1863, and devoted much time to astronomy. He erected private observatories at Bedford and Cardiff, and was president of the Royal Astronomical Society. He died at Aylesbury, Sept. 9, 1865. His son, Charles Piazzzi, had been trained in his father's observatory, and afterward was employed in the observatory at the Cape of Good Hope under T. Maclear. He made a valuable series of observations from the peak of Teneriffe in 1856, which were published in his book *Teneriffe, an Astronomer's Experiment* (1858). This was the first work illustrated by stereoscopic views. In 1843 Prof. Smyth was made astronomer royal of Scotland, and he has pursued scientific work in other countries. His most notable research was in regard to the Great Pyramid of Egypt, which he came to regard as built under Divine inspiration to fix a standard of weights and measures. This extravagant theory received some favor with a portion of the public, but not among the best scientists. The author defended it in three works: *Our Inheritance in the Great Pyramid* (1864), *Life and Work at the Great Pyramid* (3 vols., 1867), and *Antiquity of Intellectual Man* (1868). He published also *Three Cities of Russia* (1862), and some other works.

SMYTH, NEWMAN, Congregationalist pastor, was born at Brunswick, Maine, June 25, 1843. His full name was Samuel Phillips Newman Smyth, but in recent years he has discarded the two first. He graduated at Bowdoin College in 1863, and at Andover Seminary in 1867. He travelled in Europe in 1868, and in 1870 became pastor of the First Church at Bangor, Maine. In 1876 he accepted a call to the First Presbyterian Church, Quincy, Ill., whence in 1882 he was called to a professorship in Andover Seminary, but his views in regard to the future state having provoked a controversy, he was not installed. He then became pastor of the first Congregational Church, New Haven. His publications are *The Religious Feeling: a Study for Faith* (1877); *Old Faiths in New Light* (1879); *Orthodox Theology of To-day* (1881); *Reality of Faith* (1884).

SMYTH, THOMAS (1808–1873), Presbyterian minister, was born in Belfast, Ireland, June 14, 1808. He was educated at Belfast College, and studied theology at Highbury College, London, and afterward at Princeton. He was ordained pastor of the Second Presbyterian Church in Charleston, S. C., Dec. 29, 1834, and held this position until his death, Aug. 20, 1873. He was a firm upholder of the faith and practice of his church, and advocated its cause in several popular treatises.

SNAKE-BIRD. See ANHINGA.

SNAKES. This article has regard chiefly to the more noteworthy of the numerous species of snake found in America.

The Hopoterodont serpents, or "blind-worms," are worm-like creatures, generally very small, nearly all living underground, and with the eyes as a rule

scarcely discernible. India and Australia abound in species some of which (like the earth-worms they so much resemble) come above ground at certain times, and are then surprisingly active. Tropical America and Mexico have quite a number of species. *Stenostoma dulce* is a species found in Texas, having the eye tolerably conspicuous.

The Colubriiform snakes constitute a suborder embracing nearly all the harmless snakes (other than the blind-worms), as well as a certain number of venomous species. Many of our common non-venomous snakes are exceedingly useful as destroyers of noxious insects (such as ticks and beetles), as well as rats, mice, and gophers. The Uropeltidae, or shield-tails (all South Asiatic), are noteworthy as having the habit and appearance of "blind-worms." The small family Tortricidae are also burrowers; and they are remarkable for the rudimentary pelvis, with a pair of small claw-like hind limbs. *Tortrix scytale*, from the Amazon valley, is handsomely colored, and, even while alive, it is often used by the natives as a necklace.

To the family of Calamariidae, or "dwarf-snakes," are assigned a very large number of small, semi-subterranean larva-devouring species of many genera. They are generally to be found under loose stones and logs. Among our common American kinds is the timid and inoffensive *Virginia striolata*, with the back of a brownish tint, and the belly of a salmon-red; it is common southward. *Cerrophilus amœna* is the "ground-snake" or "thunder-snake," familiar to every ploughboy, a subterraneous snake, perfectly harmless, and very awkward and slow in its movements. It is also brown, with a salmon-colored belly. There are a good many other American forms, especially in the tropical regions.

To the great family of the Coronellidae belong several of the largest and best known serpents in the country, such as the *Ophibolus triangulatus*, known as the milk-snake, house-snake, or "checkered adder," and the chain-snake or king-snake of the South, the *O. getulus*, and the well known ring-snake, *Diadophis punctatus*. Here also belongs the hog-nosed snake, or sand-viper, *Heterodon platyrhinus*, rather numerous in sandy regions. It is a slow creature, of repulsive appearance and fierce aspect, hissing loudly when disturbed; but it is perfectly harmless. There are several others of its genus in this country.

Among the members of the great, yet not fully specialized, family of the Colubridæ, many North American snakes are placed. The green-snake or grass-snake, *Cyclophis versalis*, of the United States is very common, especially in New England. It is very often found in the tall grass, or even among the branches of shrubs. It is generally very gentle in its habits, but will occasionally show fight, inflicting trifling wounds with its teeth. The members of this genus, like the more strictly arboreal bush-colubers, are more frequent in America than in the old world. The mountain black-snake, *Coluber obsoletus*, having keeled scales, is a large snake found chiefly along the Alleghanies. *C. guttatus*, the brightly colored corn-snake of the South, is most active after dark. *C. quadrivittatus*, called chicken-snake, often enters human dwellings of the humbler sort, and does good by killing rats and mice; like others of its genus it often destroys young chickens. *C. rufipinus*, the fox-snake, has a rather wide range. The common black-snake, *Bronnion constrictor*, has one of the widest geographical ranges of any known species. The swift, bold, and active creature will fight bravely if brought to a pass whence there is no easy escape, and many stories are told of its fierceness and intrepidity, some of which, like too many snake stories, are no doubt exaggerations. Though not venomous the black-snake fights and destroys the more slug-

gish rattlesnake. *B. flagelliformis*, the long, swift, and harmless, though much dreaded, coach-whip snake, is very common in the South-eastern States. *B. tentatum* has a wide Western range. A green species of Bascanion is mentioned as occasionally sharing the hospitalities of the prairie-dog's burrow, together with the rattlesnake and the burrowing-owl.

The Fresh-water colubrine snakes are exceedingly well represented in North America. *Tropidomotus sipedon* is one of our commonest water-snakes, if, indeed, it be not the commonest of North American serpents. There are a dozen other American species of this genus. They feed largely on fish, frogs, and tadpoles. Country-people usually consider them venomous, probably on account of their belligerent spirit when captured. The garter-snake genus (*Eutania*) is represented here by some 20 recognized species. *E. saurita* and *E. sortalis* are our commonest garter-snakes. The latter has little fondness for the water. It is often found near piles of decaying chips and saw-dust, where it feeds upon larvæ and wood-ticks. It is harmless, but will sometimes fight bravely. *Sterzeria occipitamaculata* and *S. dekayi* are small species and not uncommon northward. The so-called Hoop-snake, *Ahastor erythrogrammus*, is a common species in the Southern and Western States. The prevalent belief that it can take its tail in its mouth and roll along the ground like a hoop is entirely incorrect. The horn-snake of the South is *Furancina abacura*, a species much resembling the hoop-snake. The water-snakes of the family Homalopsidæ are represented in the U. S. by the genus *Helicops*, one species of which has been found in Florida.

Of the "night tree-snakes" (Dipsadidæ), one species of *Dipsas* is found in Texas and Arizona, representing a remarkable and widely disseminated genus. The species are generally long and slender. The name *Dipsas* is Greek, and signifies "thirsty"; the ancients believed that the snake of this name had an unquenchable thirst which it imparted to those who were bitten by it. It is needless to add that this belief was not founded upon facts. The great black gopher-snake, or indigo-snake of the Southern cotton-belt (*Spilotes cooperi*), is said to attain the length of 12 feet. It is bold and active and is believed occasionally to occupy the same burrow with one or more of the larger tortoises (also locally called "gophers" or burrowers). This genus is chiefly South American. The common pine-snake or bull-snake of the east (*Pityophis melanohircus*) is a large and very swift creature, common in pine-forests. *P. bellona* is a very common and important Western form, which is not only harmless but exceedingly useful as a vermin-destroyer. The swift and spiteful snakes of the genus *Dromicus* are common in tropical America, and *D. flavilatus* is sparingly found in the cotton-growing States. It is grouped with the semi-arboreal colubrines. The true tree-snakes, or Dendrophididæ, are very abundant in tropical America, and a few species are Mexican. The Dryophididæ, or whip-snakes, are very slender tropical forms, some of them American. A few of the Scytalididæ are Mexican, and others are South American.

The family of Amblycephalidæ, or blunt-heads (chiefly East Indian), has several South American representatives.

To the Eryceidæ, or sand-snakes, mostly old-world desert forms with some boa-like features, belong several American genera; and *Charina*, *Wenona*, and *Lichanura* are strictly North American forms, presenting many points of interest to the naturalist.

The very remarkable old-world family Pythonidæ has but a single known American representative—a little known and very singular species of *Loxocemus*. On the contrary, the Boidæ (excepting a few Poly-

nesian and Australian species) are all American. *Boa imperator*, the emperor-snake of Mexico, approaches closely to the well-known *B. constrictor* of S. America. Closely allied are *B. mexicana* and *B. isthmica*. Here belongs the anaconda (*q. v.*) of literature, though the original anaconda was East Indian or Ceylonese. *Xiphosoma caninum* is the dog-headed boa of Brazil, with a generally greenish hue, varied with bands and spots of lighter tint.

Epicratus ventriosus is one of the species called aboma (which is strictly the name of an African snake). The ancient Mexicans used to worship this serpent with bloody rites.

The venomous snakes of America are very numerous. The great family Elapidae has many genera—one of which, *Elaps* proper, has many South American species. *E. fulvus* is the showily variegated little harlequin snake of the Southern States. It is singular that this little reptile, though undoubtedly venomous, is regarded by almost all who know it as perfectly harmless. At ordinary times it is not easy to provoke it to bite.

Of the exceedingly venomous Hydrophidae, or sea-snakes, so common in the Indian Ocean, only one species, *Pelamis bicolor*, ranges eastward across the Pacific to tropical America; and the same or some other has been reported, perhaps incorrectly, from the Atlantic waters of Central America. The exceedingly venomous family, Causidae, chiefly African, has one Venezuelan representative, a *Dinodipsas*. A characteristic family, though one not peculiar to America, is that of the Crotalidae or pit-vipers. The common copper-head, *Ancistrodon contortrix*, has a wide range in N. America, and is exceedingly venomous. Still more dreaded is the water-moccasin, *A. piscivorus*, of the Southern States. The terrible *fer-de-lance*, *Trigonocephalus lanceolatus*, is found in some of the West Indian Islands.

For a description of the Rattlesnake the reader is referred to the ENCYCLOPÆDIA BRITANNICA. Besides the species named we may mention as noteworthy

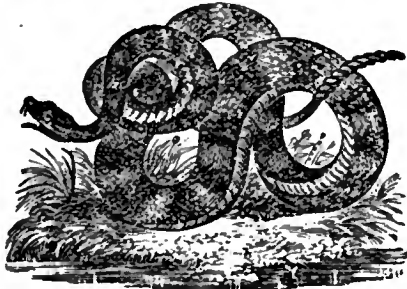

THE RATTLE-SNAKE.

Crotalus molossus of New Mexico and Arizona; *C. confluentis*, the common prairie-rattlesnake; *C. lucifer*, the black rattlesnake of the Pacific States; *C. cerastes*, the horned rattler, or side-winder, of New Mexico. The small rattlesnakes of the genus *Caulidorsa* are very commonly designated by the aboriginal name of Massasauga. There has been described a species of rattlesnake called *Aplouspis lepida*, from Western Texas, which has been considered the most highly specialized of all the group, if not of all existing snakes.

It is probable that every state and territory of the Union is at least locally infested by rattlesnakes of one or more species. In the New England States they are for the most part limited to very rocky and thinly settled tracts—the finely splintered trappean surfaces on the sunny sides of such ridges as that of Mt. Holyoke and Mt. Tom being especially adapted to their habits. The abandonment and reforestation of old farm-lands in New England seems to be lead-

ing to the return of the rattlesnake to districts where he has long been a stranger. It is asserted that the rattlesnake of New England is especially dangerous, and that the proportion of deaths following from its bite is much larger than that observed in more southerly latitudes. Much more certain is it that the largest species of rattlesnakes are as a rule the most deadly; the bite of the little "massasauga" being not nearly so dangerous as that of *Crotalus horridus*, or the South American *C. durissus*, or the great diamond rattlesnake that haunts the swamps and hammock-lands of the Gulf States.

The one remedy, and the only one worth considering for rattlesnake-bite, is whiskey or its equivalent. The snake-poison is a tremendous heart-depressant, and the only remedy is the direct counter-poison (or "physiological antidote") of alcohol, a heart stimulant; for there is no known and available chemical antidote. The amount of stimulation the patient will generally bear after a snake-bite is very wonderful. The remedy should be pushed vigorously, but not inconsiderately. As a rule, when signs of intoxication begin to be discernible the stimulus must be given with greater moderation. If spirits of ammonia, or pure ethylic ether, be at hand, it is well to begin the treatment with a large dose of one or both, by reason of their speedy action; but the slower alcoholic stimulation is much more effective.

It is well known that savages everywhere, at least when pushed by hunger, will eat the flesh of serpents. It is equally well known that in Europe asp's flesh was regarded (as it still is locally) as a sovereign remedy for various ills and diseases; and one theory of the derivation of the name *aspic* as given to a favorite made-dish of the European cuisine is that it originally contained stewed asps. It is, however, much less generally known to the reading public that the rattlesnake is eaten by white people, not only in Lower Canada but also as far south as the Gulf of Mexico. At a time not yet distant the flesh of the rattlesnake was served up upon the well-appointed tables of wealthy and not unrefined planters and prosperous towns-people in the Gulf States. By way of euphemism the serpent's flesh was called "musical squirrel," or by some other similar disguise. All the recorded testimony confirms the statement that rattlesnake meat is tender and delicate and of good flavor. Rattlesnake's oil is regularly kept for sale in many drug-stores. Thousands of country-folk believe that it has singular virtues as a remedy; and along with skunk's-grease, opossum-fat, dog-fat, and raccoon-tallow, it meets with a ready sale at good prices. Its virtues are, in fact, much the same as those of lard or goose-grease. There is no reason to believe that it has any special qualities which give it a value above that of any other animal oil.

The name "blind-worm," applied in the early part of this article to snakes of the genus *Typhlops* and the allied forms, is in English literature given to *Anguis fragilis*, "which is neither blind nor a worm," but a snake-like lizard, mentioned here solely as one of a rather numerous group of limbless lizards, popularly confounded with true snakes. One of the most interesting of these creatures is the "glass-snake," *Ophiuros ventralis* of the Southern States, so called from the brittleness of its tail, which is very readily broken off. Very similar are the European glass-snake, *Pseudopus pallasi*, *P. gracilis* of India, and the African *Hyalosaurus*. Australia has a great number of limbless and snake-like lizards, and there are several in the Californian region. Among other limbless vertebrates are the *Cæciliidae*, chiefly tropical and subterranean in their habits, often eyeless or nearly so. They are batrachians, and not true reptiles. The *Amphisbænidae*, also serpent-like and nearly blind, are true lizards. They

are mostly South American, but *Rhinewra floridana*, the "thunder-worm" of Florida, may be assigned to the same family. (c. w. a.)

SOAP. The manufacture of soap has for many years been an American industry of considerable importance, its growth being such that the United States has long ceased to be a considerable market for European soaps, and now competes with England and France in exportation to foreign countries. Marseilles, long the market of the finer toilet-soaps, no longer enjoys a monopoly in this direction, large quantities of such soaps being now made in this country, both for home consumption and for export. Soap and candles (formerly made at the same factories) were imported largely into the United States until about 1821, when, under the encouragement of a protective tariff, their manufacture became active in this country. Up to that time only soft soap (largely as a domestic manufacture) and common laundry and toilet soaps had been made here, but better qualities were now manufactured, and on a scale that greatly reduced importations. In 1864 the duties were increased from 3 to 10 cents per lb., since which time the finest grades of perfumed toilet-soaps have been manufactured in America in quantities sufficient not only to supply the home market but to sell extensively abroad.

The primitive American soaps were made with potash instead of soda, potash being then derived from the forest-refuse in much greater quantities than at present. This is still the case with home-made soaps where potash continues a common product, as in Canada and several of the States, but the cheap production of caustic soda during the present century, by what is known as the Le Blanc process, has in most places replaced potash by soda as the alkali of soap. The kitchen fats, chiefly those of beef and mutton, were saponified with crude potash to form the soft soap of the early American household. The recipe ordinarily used, and which has become traditional in country-kitchens, is the following: 12 lbs. of fat and 9 lbs. of potash are steeped in boiling water in a cask, the water being added 3 gallons at a time every 24 hours until 12 gallons have been added. Saponification soon begins, but takes many days for its completion, the mixture being frequently stirred. When completed all the fat lumps have disappeared, the soap has a silky lustre when stirred, and is of the consistency of a jelly. It is a powerful detergent for coarser household purposes, and is preferred to hard soap for scrubbing floors, washing crockery, and the like. It is not a true soap, chemically considered, but a solution of a potash soap in caustic lye, with free glycerine. In improved processes the potash lye is boiled with kitchen fats and other oily substances until the mixture becomes a clear, transparent, slimy liquid. The detergent powers of this are very great, from its strongly alkaline condition, and it is much esteemed for such processes as scouring wool, coarse linens, etc. The hard bar-soaps of America are made in a very similar manner, but of choicer materials, to which are added 25 to 30 per cent. of powdered rosin. At the present day the manufacture of soap is an American industry of considerable importance, several of the factories confining themselves to the choicest grades of fancy and toilet soaps, in the production of which they are on a level with the best European manufacturers. In 1880 there were 629 establishments engaged in this business in the United States, employing 5,589 hands, and yielding a product valued at \$26,552,627. Nearly one-fourth of the whole product was made in the State of New York; Massachusetts, Pennsylvania, Illinois, and New Jersey coming next in order. We have no later statistics of manufacture, but the importations and

exportations for 1886 were as follows: Toilet soaps imported—value, \$178,673; other grades, \$258,623; total value, \$437,296. Exportations of toilet and fancy soaps, \$60,646; of other grades, \$772,131; total value, \$832,777—the exportations of soap thus exceeding the importations about \$400,000. This, then, is one of the industries in which the United States not only can stand alone, but is able to compete successfully with Europe for a foreign market. (c. n.)

SOAP STONE. See TALC.

SOCIALISM. No movement of modern times has

awakened or deserved greater attention than the one indicated by this title. Its accurate definition is exceedingly difficult, owing to an entire lack of agreement concerning the true limits of the word "Socialism." In general, it may be described as that movement which seeks by economic changes to destroy the existing inequalities of the world's social conditions. For convenience of discussion it may be best to divide the Socialists of America into two classes: First, those who believe the necessary changes can be secured only by the early or immediate employment of force; and, second, those who believe in more conservative methods, such as agitation and peaceful combination. Into all socialistic schemes the idea of governmental change enters, with this radical difference, however: some Socialists rely upon the final abolition of existing forms of government and seek the establishment of a pure democracy, while others insist upon giving to government a paternal form, thus increasing its function and power instead of diminishing it. Of course, its paternal functions are to be exercised in the interest of the wage-toilers of the country.

1. The more radical wing of the Socialists of America has given expression to its life and views in the several platforms and declarations of the International Working People's Associations and the International Workmen's Association, sometimes designated as the "Blacks" and "Reds," respectively. The latter are regarded as the more moderate and conservative wing, and have probably the larger constituency in America. The International Working People's Association ("Blacks"), in a manifesto issued a few years ago in New York, after reciting the grievances under which the laboring classes rest by reason of the oppressions of capital, proceeds to declare "that they (the oppressors) will not resign these privileges voluntarily we know, that they will not make any concession we likewise know. Since we must then rely upon the kindness of our masters for whatever redress we have, and knowing that from them no good may be expected, there remains but one recourse—FORCE. Our forefathers have not only told us that against despots force is justifiable, because it is the only means, but they themselves have set the immemorial example." They avow, among others, the following demands: 1. Destruction of the existing class-rule by all means, *i. e.*, energetic, relentless, and international action. 2. Establishment of a free society, based upon co-operative organization of production. 3. Free exchange of productions of all sorts. 4. Secular education. 5. Equal rights for all sexes and races. 6. Public affairs to be regulated by free contract. This section of Socialists believes in the use of dynamite and other explosives as means to the end of social regeneration. The International Workmen's Association published in 1884 a *Declaration of the Rights of Man*, which is given to the world in a brief treatise on *Socialism*, by A. J. Starkweather and S. Robert Wilson. This manifesto was issued in San Francisco, Cal. It declares that liberty is the power which belongs to a man of exercising all his faculties at pleasure.

Every individual is entitled to an equal proportional share of all the natural advantages of earth. The whole people should hold the land, light, air, and water, together with other of nature's resources, as the natural heritage in common of all mankind. Every individual is entitled to an equal proportionate share of all accumulated wealth created by past generations, and that wealth should be held by society as the natural heritage in common of all mankind. Debt, profit, interest, rent, and the competitive system of industry are declared instruments of degradation and tyranny, and cancers upon the social body. So, also, are the present methods of punishing crime, the present monetary system, the present methods of suffrage, education, jurisprudence, church and military. The right of property is substantially limited by the rights acquired by production. So long as members of society fulfil their portion of the social contract they have a right to demand of society the means necessary to provide for their subsistence. Society is bound also to insure the means of existence to those who are incapable of labor. Every act against the imprescriptible rights of man, by whomsoever exercised, even in the name of the law itself, and within the forms it prescribes, is arbitrary and void. The very respect due to law forbids submission to it, and if the attempt be made to execute such act by violence or by artifice, it is not only permitted, but enjoined upon every individual to repel such assaults even by force. Government should be as nearly as possible pure democracy. Governments, as at present constituted, are simply means of enslavement. Appended to this Declaration is an explanation of the method of organization of the I. W. A., in which the individual workman is invited to gather a group of seven others, and, after a series of educational conferences, the members of this group are to become individually the leaders of other groups of eight, and so on—the object of these gatherings is stated to be education—in rights and in chemistry!

2. Next should be named that class of Socialists seeking immediate social renovation by sweeping and revolutionary changes, but by methods which are conservative. The Socialist Labor Party most distinctly represents this class; it proposes to accomplish its ends gradually, but seeks as present possibilities: 1. The establishment of a Bureau of Labor in connection with the U. S. government. 2. Reduction in the hours of labor. 3. Abolition of convict labor. 4. The enactment of an employers' liability law. 5. The prohibition of child labor. 6. Compulsory education. 7. Factory, mine, and workshop inspection. 8. Inspection of food and dwellings. 9. Payment of all wages in cash.

3. A still more modified form of socialism has arisen in connection with the adoption of the theories of Henry George as expressed in his work *Progress and Poverty*. This has given rise to the formation of the Anti-Poverty Society, whose work for the present is mainly educational, but which aims at a final enforcement of its views by political action. It declares: "That all men are created by Almighty God with certain inalienable rights; that these inalienable rights are rights to life, liberty, and the pursuit of happiness; that life cannot be had without proper access to the materials of which this earth is made, and that therefore God has given an equal and indefeasible right to each and everyone of his children of access to these materials; that no prescription, no vested right, no law can deprive the child of a beggar of the same right as the child that is born of an imperial throne possesses to equal common ownership of the bounties of nature." Proceeding upon this assumption, it is claimed that the painful inequalities of existence are due to the infraction of a natural law. Land being the common property

of all, the wealthy landholder is enriched by an increase of value in his land which is an "unearned increment;" and the population which caused the increase ought to be rewarded with what itself has created. All private ownership in land should be abolished, and the community should take in taxation its rental value.

4. Christian socialism. Recognizing the manifest wrongs and burdens concomitant to our present economic conditions, a large number of Christian writers have addressed themselves to this subject. Their labors have been confined to seeking ameliorations rather than radical changes at the present, and to emphasizing the idea of human brotherhood, in response to which, it is claimed, men should seek more nearly to equalize the conditions of human life by justice that is kind rather than to repair the ravages of injustice by charity. This form of socialism, which is claimed to grow out of the life of Jesus and from the very spirit of the gospels, is a powerful factor in the life of America to-day, and cannot fail of a favorable reaction on the violent spirit of discontent excited by philosophic socialism.

American Socialists, with the possible exception of many in the last-named class, are generally agreed, according to Prof. R. T. Ely, on four points: the first of these is that it is desirable to abolish private property in instruments of production, not in income, so far as this consists simply in articles of use and enjoyment and which cannot serve as a further basis of production. 2. Not to abolish capital, but the distinct class of capitalists. 3. They believe in the use of the best machinery and in improved methods of production, and in the organization of production on a vast international basis. 4. They believe in co-operation as a substitute for the wage-system.

The growth of socialism in this country has been rapid and will probably keep pace with the just causes of discontent. The centralization of wealth, the rise of monopolies, the control of many of the necessities of life by gigantic "trusts," accompanied as they often are by combinations on the part of employers to restrict the wages and restrain the liberty of the employed by means of "ironclad oaths" and "black lists"—these are denounced as artificial forms of oppression which are superadded to the natural disadvantages arising for the laboring classes by reason of the use of improved means of production and the rapid increase of laborers by unrestricted immigration. The *Republic* of Plato and the *Utopia* of Sir Thomas More were early expressions of human yearning to which Christian prophecy responds in the promise of a millennium. It is not improbable that a gradual advance in liberal legislation, whereby the powers of avarice shall be limited and the rights of the toiling masses shall be restored, may avert the use of violence, and that in the orderly advance of a Christian civilization there shall come at last to the people of this country an equitable and universal distribution of those advantages which our possession of nature's gifts and our inheritance of centuries of advance in intelligence and power shall afford.

The socialism that is linked to materialism is threatening and violent; its only hope of ameliorating the condition of the oppressed is in the use of force. Those forms of socialism which are affected by Christian thought are hopeful of a solution of existing difficulties by methods that are educational and peaceful. That the wrongs complained of are real, that they are becoming more burdensome with the advance of time, and that they will become unendurable if left to go on unchecked, is apparent to every thoughtful mind. The cure by violence is full of suggestions of horror. It may be avoided if, instead of ignoring these wrongs, men will address

themselves to the remedy, and, by giving emphasis to the idea of human brotherhood, secure such concessions to the world's toilers as shall bring greater possibilities of happiness to all.

Literature: W. H. Fremantle, *The World as the Subject of Redemption* (London, 1885); Henry George, *Progress and Poverty* (New York, 1883); R. T. Ely, *The Labor Question* (New York, 1886); A. J. Starkweather and S. Robert Wilson, *Socialism* (New York, 1884). A brief list is also appended of periodicals devoted to the dissemination of socialistic ideas. *Truth*, monthly, San Francisco; Burnette G. Haskell, editor; *The Labor Enquirer*, weekly, Denver; J. R. Buchanan, editor; *Examiner*, weekly, Hartford; *Sociologist*, monthly, Knoxville, Tenn.; *New-Yorker Volks Zeitung*, daily, New York; *Arbeiter Zeitung*, daily, Chicago; *Tageblatt*, daily, Philadelphia; *Freiheit*, weekly, New York; *Forbats*, weekly, Chicago; *Die Fackel*, weekly, Chicago; *The Free Soiler*, monthly, New York; *Journal of United Labor*, Philadelphia; *The Protest*, Exeter, N. H.; *Man*, weekly, New York; *The Truth Seeker*, weekly, New York; *The Radical Review*, Chicago; *Lwisfer*, weekly, Valley Falls, Kan.; *The Non-Conformist*, daily, Haverhill, Mass.; *Mail*, daily, Stockton, Cal.; *Labor Herald*, Pittsburg; *Labor Standard*, Paterson, N. J.; *Labor Free Press*, Baltimore; *Advertiser*, Trenton, N. J.; *Irish World*, New York; *Union*, St. Louis; *Fidette*, Salem, Oregon. All the last named are weekly papers. (T. A. E. O.)

SOCIETIES, MUTUAL AID. Man is a gregarious animal in a far more comprehensive sense than any of the lower animals. Each community not only combines as a whole for mutual aid and assistance, but within every civilized community are numerous minor aggregations, wheels within wheels, combined for more specialized purposes of mutual benefit, and designed to cover almost all the needs and wishes of man which can be helped by association. There are numerous societies for political, literary, scientific, social, and recreative purposes, whose object is to aid each other in amusement, the acquisition of knowledge, the gaining of public rights, etc., but none of these are included within our present purpose, which is confined to the consideration of societies organized to aid their members in gaining the means of livelihood, and in most of which pecuniary help in case of sickness or death is a leading feature.

Societies of this character have existed from a remote period. In ancient times they can be traced in Greece and were numerous in the Roman Empire, their methods and aims being not unlike those of modern societies. In the mediæval period the principle of mutual benefit association was active. The trade guilds, the most important of the associations of that era, were numerous and powerful, and in certain localities went so far beyond their original function as to exercise a controlling influence upon government. These associations differed radically from the trade unions of to-day. They were organized not against capital but against labor competition. Labor in those days was its own employer, the masters had begun life as mechanics, and the interest of one was the interest of all. The guilds established rigid rules to prevent an overflow of labor from without into their organizations, and with such effect as to divide the lower rank of society into two classes: one of masters, mechanics, and apprentices in the trade guilds; one of laborers, tamps, and beggars who were refused admittance to these guilds. It was an artificial state of society, but it long held its own in opposition to the force of the natural law of industry. The guilds were important institutions in that era, and accumulated property, much of which still exists, though the societies themselves have been reduced to mere shadows, and exist simply to take care of this property. Pecuniary aid in case of distress was a feature of the guilds, and was a leading characteristic of certain charitable and social societies which existed at the same time, and which approached our modern beneficial societies in character and purposes, the

supply of a burial fund being one of their leading features.

There is, however, a definite line of division between mediæval and modern times in respect to the principles of labor association. The rise of the factory system, and the employment of great sums of money in single manufacturing enterprises, gave the death-blow to the guilds. They vanished as vital organizations, and have been succeeded by the trade unions, in which the principle of exclusion of outside labor still exists, but only as a minor object, the major object being that of preventing the encroachments of capital. The contest is now for an equitable division between labor and capital of the profits arising from manufacturing enterprise, this being one of the most difficult questions to settle that has arisen in modern history.

By the side of these trade unions have arisen many mutual aid, or "friendly societies" as they are called in England, which have no connection with the labor question, but limit their purposes to the single one of pecuniary assistance in the case of accident, sickness, or death. In these societies the members make weekly or monthly contributions to a common fund, accumulating a sum which is paid out again in definite weekly amounts in case of sickness or accident to any member, and to aid in the burial of members in case of death. In other cases there is no payment except a given sum for burial, while some mechanics' societies have a fund to pay for loss of tools by accident or otherwise.

As the trade unions are all new societies, none of them being continuations of the guilds, so the same may be said of the mutual aid societies, with one exception, that of the Free Masons, which alone has come down to us from mediæval times. (See articles on FREE MASONRY in the ENCYCLOPEDIA BRITANNICA and in this work.) The Free Masons is the strongest and most influential of modern secret societies and possesses a very intricate organization, the main body being supplemented by higher "degrees," some of which are almost distinct societies in themselves.

Next in importance comes the Independent Order of Odd Fellows, a society of English origin but which, like the Masons, has become very strong within the United States. The exact date of its origin is not known, the first trace of its existence being in 1745, when it seems to have constituted a secret society for convivial purposes, with a small fund for the relief of poor and burial of deceased members. About the same time another important English society, the Ancient Order of Foresters, came into existence. This is to-day of considerable strength in England, and has established itself to some extent in the United States. The Order of Druids is another English society of some strength, while several others might be named of minor importance. In the last century these societies had not the definite organization and purposes of more recent times, their beneficial feature being of secondary importance. It was in 1812 that the Odd Fellows Society reorganized itself for the purpose of mutual assistance in prescribed sums in case of sickness and in the defraying of funeral expenses. In imitation of the Free Masons, it devised pass-words and signs for the mutual recognition of members and to prevent imposture, established new rules of order and better defined conditions of management, and assumed its present name of "The Independent Order of Odd Fellows." This new departure was a distinct advance on the informal workings of the preceding benevolent and charitable institutions, and gave the cue to the organization of the more recent societies. The Free Masons alone retain the generalized conditions of pecuniary aid of the earlier period, other societies binding themselves to the payment of fixed

sums in case of sickness or death. The first governmental recognition of these associations was made in England in 1793, when an act was passed designed to place them on a firm footing, by giving them a legal status, permitting them to hold property, and to sue and be sued in courts of law. This act was repealed in 1829 and a new law passed, which has been succeeded by several others, the latest being that of 1875.

Of the English societies the Masons and the Odd Fellows are both largely represented within the United States. The first lodge of American Masons was organized in Boston in 1733, and in the following year one was instituted in Philadelphia, with Benjamin Franklin as its Worshipful Master. There are more Masons in the United States to-day than in any other country in the world, their strength here being over 600,000. The order of Odd Fellows was brought to America in 1819, when a lodge was founded in Baltimore by some members of the Manchester Union. It grew rapidly, and in 1842 the American branch cut loose from the parent society of Great Britain, in consequence of certain differences in their working rules. Since that period the society has flourished in the United States, and is strong numerically and financially at the present day, its membership in this country being over 600,000 with nearly 10,000 lodges.

In addition to the societies of English origin there are a considerable number of American institutions, some of them of national importance. The Knights of Pythias was founded in Washington in 1864, its expressed object being "peace on earth and good will toward men," and to disseminate the "great principles of friendship, charity, and benevolence." It became a popular order and has grown rapidly, having in 1885 more than 2000 subordinate lodges and over 160,000 members. A society of earlier origin is the "Red Men," in whose lodge-meetings the customs and dress of the American Indians are simulated. This has not grown in later years as rapidly as some other societies, but is to-day in a prosperous condition. Another of the older American societies is the "Order of American Mechanics." Some societies of more recent institution, however, have surpassed in popularity those older ones, and notably "The Knights of the Golden Eagle," which has at present 281 "castles" or lodges in Pennsylvania alone. Of recent years the disposition to found new societies has been active, and many have come into being, among which may be named "The Knights of Malta," "The Senate of Sparta," "The Knights of the Mystic Chain," "The Legion of the Red Cross," "The Royal Arcanum," "The Brotherhood of the Union," "The United Workmen," "The Patriotic Sons of America," "The Knights of Friendship," "The Universal Order of Security," and "Order of the Iron Hall." This is not offered as a full list. Other societies could be named, while there are many which are as yet of local importance only. But in the list of important mutual aid societies of the United States must be included "The Grand Army of the Republic," an organization composed of the veteran soldiers of the civil war, and one that is worthy of the highest respect of the American people.

These various societies are differently constituted, and have different methods of beneficial procedure. In some, new members are examined by a competent physician; in others, the dues vary in accordance with the age of the member; in certain societies of recent origin benefit payments are made only in case of death, a sum being paid sufficient for the burial of the deceased member and the temporary support of his family. In these the members are assessed for dues only when the death of a fellow-member takes place, and the dues vary with the number of

deaths. These societies are conducted on the life insurance principle, and some of the older societies have adopted a similar principle, permitting their members to insure their lives for fixed sums by making payments in accordance therewith. One recent society which combines the payment of sick benefits with life insurance is that known as the "Iron Hall," whose working principle has been adopted by other organizations known as the "Order of Tenti" and the "Sexennial League." Numerous other societies, of local interest, might be named, all based on the useful principle of aiding their members in seasons of distress. Each new society seeks to afford the most help for the least payment, and it must be confessed that much progress has been made in the beneficial management of society funds.

In addition to the mutual aid societies organized expressly for charitable and insurance purposes, there are numerous associations which add to this aim others of equal importance. There are two particular classes of these societies, the labor unions and the temperance associations, both of which call for some consideration. With the growth of the factory system of labor, as we have already said, trade unions took the place formerly occupied by the guilds, which had long ceased to be vital organizations. The combination of working-men in opposition to capital began in England in the latter part of the last century, particular opposition being shown at that time to the introduction of new labor-saving inventions. There is no evidence that any such societies existed in America during the colonial period. Home labor was then the rule, and there were no large collections of mechanics in industrial centres. But by the opening of the 19th century the modern conditions of labor were well established, and the long conflict between labor and capital had begun. Something like a strike took place in New York in 1802, when the sailors of that port quit work to enforce an advance of wages from \$10 to \$14 a month. Organizations of labor appeared at the same time, beginning in local combinations of single trades. The New York Society of Journeymen Shipwrights was formed in 1803, and a society of House Carpenters in 1806. In 1817 the New York Typographical Society is spoken of as a strong institution. Yet up to 1825 there is little trace of such societies outside of the State of New York.

After 1825 labor showed a disposition to combine on a larger scale. The local unions increased in number, and the idea of national unions arose. The two cities most prominent in this movement were Boston and New York. In 1833 an address was made before "The General Trades Unions of the City of New York," the first indication we have of the effort to combine all the workmen of one locality. A premature attempt to form a national trades union was made in 1835, though with no definite result, and it was not till after 1850 that any efforts to organize national unions became successful. Of these the earliest was the National Typographical Union, traceable to 1850, but not permanently organized till 1852. In 1869 its name was changed to "The International Typographical Union," with the purpose of including the printers of Canada. This is the oldest American trades union now in existence, all the earlier ones having vanished. The latter combined in 1854; the iron and steel workers in 1858; the iron moulders, and the machinists and blacksmiths, in 1859; and it is said that 26 trades had national organizations in 1860. These national unions were followed by the so-called international societies, most of which, however, are international only in name. In 1864 the Grand International Brotherhood of Locomotive Engineers was formed, and that of the cigar-makers in the same year. Societies of this national character were formed with

rapidity after that period, until to-day there is scarcely a distinct trade without such an organization.

The next step in the process of combination was the effort to form a national organization of all the trades. This was taken in 1866, when the National Labor Union was formed. It grew rapidly in numbers for a few years, and then declined and died out. A more successful effort was made in 1869. On Thanksgiving day of that year Uriah S. Stevens, a Philadelphia tailor, called a meeting which proved the initial step in the organization of the Knights of Labor, a society which in 19 years has grown into the most powerful labor organization of modern times. It differs from all previous labor societies in including all branches of skilled and unskilled labor in its organization, its expressed purposes being mutual aid of members, protection against the encroachments of capital, and the attainment of reforms in industrial relations. This society admits all men to membership except bankers, brokers, professional gamblers, lawyers, and liquor makers and sellers, and is the first of such societies to recognize the claim of unskilled labor to the same protection which skilled labor has so long possessed. Other general societies on a different basis have been instituted from time to time, constituting federations of labor unions, delegate bodies to which each subordinate union sends a representative. Such labor congresses now exist in all the large cities of the Union. In 1881 there was organized in Pittsburg, on a national basis, a "Federation of Organized Trades and Labor Unions," on the model of the trade-union congress of England.

Just how many persons are included in these American trade societies is not known. It cannot be less than a million, and may be much more. In 1880, according to the Census Report, there were 2440 such societies in the United States, representing 132 industries. Of these one-quarter of the whole (620) were located in the State of Pennsylvania, while no other State had much over 200. This is a natural result of the great importance of Pennsylvania in the mechanical industries. The same State leads in benevolent and beneficial organizations—probably from the same cause. The societies above described, the strictly beneficial, and in some cases the labor associations, are often the only savings banks of working-men, being accident, sick, and life insurance companies in which the small weekly dues paid by the members are frequently their sole provision against future want. These dues are usually from 12 to 15 cents per week. The trade societies protect their members against reduction of wages and pay them benefits during strikes, thus serving a doubly useful purpose. In this connection it is necessary to mention the socialist societies which have gained so unenviable a reputation in recent years. Of these there are three in the United States: "The Socialistic Labor Party," "The International Working People's Association," and "The International Workmen's Association." It is the last named of these which has rendered itself so objectionable by its open advocacy of anarchical violence, and by the murderous use of dynamite as an exemplification of its principles. It is chiefly composed of the most turbulent element of European labor, disposed to put in practice here methods devised against the oppressive governments of their native soil, but in no sense applicable to American institutions. The others named are to some extent anarchical in their principles, but have not yet proved so in their practice. (See SOCIALISM.)

Of the remaining societies in which the mutual aid of members is a prominent feature, that of the Grangers, or Patrons of Husbandry, has been already treated (see GRANGERS). Its purposes are largely

social, but mainly protective, including the purchase of goods and machinery at producers' prices and mutual defence against railroad discrimination. We have yet to mention the temperance societies, in which a crusade against liquor is the principal feature, though in some cases combined with financial aid to members. The associated temperance movement began early in the century, and grew very active after 1825, but the existing orders of temperance did not come into being until 1842, when the "Sons of Temperance" society was organized. In the same year there was introduced into the United States an English society, "The Independent Order of Rechabites," which had existed since 1835. It spread with great rapidity in this country, and had at one time more than 100,000 members, but has now but a small fraction of that number. The Sons of Temperance grew with yet greater rapidity, and in 1850 had 232,233 members. It declined greatly during the civil war, but it is now growing again, and in 1888 numbered 78,913 members. It is a secret society, admits to membership women as well as men, and colored as well as white men, and is beneficiary in its workings. This pioneer society was followed in 1851 by the "Order of Good Templars," which left out the mutual aid principle, and made temperance reform its sole purpose. This society grew very rapidly, extended, like the Sons of Temperance, to England and other countries, and has lodges now in every country of the civilized world. In 1875 it had in all 735,000 members. Since then it has declined in numbers, its strength in 1888 being 483,103 members. Women are eligible to membership, and there is a juvenile branch having, in 1888, a membership of 139,951. Juvenile temperance has made great progress in other societies, as the "Cadets of Temperance," and the English "Band of Hope Union," which is said to have over 800,000 members in Great Britain and Ireland. Other American societies are the "Templars of Honor and Temperance," organized in 1845; the "Independent Order of Good Samaritans and Daughters of Samaria," organized in 1847; the "Royal Templars of Temperance," organized in 1869; and a considerable number of smaller societies of local interest only. Temperance societies exist in many churches, the most publicly prominent of these being the Catholic Total Abstinence Beneficial Society, which has done great good in its crusade against strong drink. Of recent societies, however, the most important is the Woman's Christian Temperance Union, which has been exceedingly active in the cause of temperance reform, and has very recently combined many of the juvenile temperance organizations into a single society, "The Loyal Temperance Legion," whose membership is estimated at 500,000. There are other temperance societies of recent organization, such as the "Law and Order Society," "The Reform Clubs," etc., but as these last-named societies do not belong to the beneficiary class they need not be further mentioned.

What has been above said is sufficient to show that the idea of association for mutual benefit has had a remarkable development in the United States during the nineteenth century, and that at present the membership of such societies includes a very considerable portion of our population. It might be shown also that these societies have made no less progress in their methods of beneficiary procedure, and the skilful handling of their funds, the experience of life insurance companies having proved highly useful to the mutual aid societies. As at present constituted, in fact, every degree of progress in this direction can be traced in the workings of the several societies. In the Free Masons, for instance, we have a retention of the mediæval general and non-obligatory system of charity. Other socie-

ties retain the early methods of sick benefits, while still others have introduced life insurance as an important feature of their beneficial methods, though the legality of this attempt has been seriously questioned. Others add to the mutual aid idea purposes of self-defence against the encroachments of capital, and of aggression against the liquor interests and the ravages of intemperance. The mutual aid feature of these societies is of the utmost importance and value to the industrial portions of our population, they forming, in a majority of cases, the only bulwark of their members against want in case of sickness and accident, and assurance of relief to their families in case of death. (C. M.)

SODA. Of all the chemical products used in human industries soda is far the most important, and the increase in its consumption has borne an intimate relation to the progress of civilization. Formerly, of the two salts soda and potash the latter was the more important, being most abundantly and cheaply produced. The chief source of soda at that time was the ashes of certain sea and sea-shore plants. In 1791 the Le Blanc process of producing carbonate of soda directly from common salt was perfected, and since then the use of soda has grown enormously. In this process salt is decomposed by the aid of sulphuric acid, and sodium sulphate or "salt cake" produced. Sodium carbonate is then produced by mixing the salt cake with limestone and charcoal, or small coal. This process has never been employed in America, except on a small scale. In 1866 Ernest Solvay, of Brussels, devised what is known as the ammonia process. In this a solution of bicarbonate of ammonia is mixed with common salt, and decomposes it, yielding a bicarbonate of soda precipitate and a solution of ammonium chloride. This process is growing in favor, and is employed in the soda manufactories now existing in the United States. Of recent years the American production of this substance has largely increased, though it is yet far below that of Europe. About one-fourth of the soda now used is made by the ammonia process. A factory employing this process was established at Syracuse, N. Y., in 1881, using the salt of the wells of that state, and has now a capacity of about 40,000 tons annually. Another factory has been recently started at Syracuse, to make fine sulphate of soda for glass-makers' use. Yet the soda used in this country continues to be in large part imported from England, the proportions being, in 1885, 167,083 tons imported to 15,000 manufactured. The importation of the various salts of soda in 1886 amounted to 368,766,594 lbs., while about 10 per cent. of this quantity was produced in the United States. In the manufacture of soda, it is interesting to observe how greatly the industry has been diverted from its original object. Soda, originally the only valuable product of the Le Blanc process, has now become but a by-product. The hydrochloric acid yielded in the process first became valuable through the growing demand for chlorine, and more recently the production of soda and chlorine have both become unprofitable, and the chief profit comes from the utilization of the process in the wet method of extracting copper from its ores. The growth of the ammonia process comes from the growing abundance and cheapness of ammonia, which is now obtained commercially from coke-ovens and from the gases of blast furnaces. It appears possible, indeed, to collect and utilize a portion of the nitrogen of nearly all fuels, and it has been suggested that the soda-maker shall cease to use raw coal as fuel, but coke it, collect for sale the oil and ammonia evolved, and use for heating the gases yielded in coking and the coke itself; thus obtaining his fuel virtually without cost.

The materials for making carbonate of soda are of unlimited abundance in this country, yet the cheapness of foreign labor has hitherto prevented successful competition. Soda is made in limited quantities at Philadelphia from the cryolite of Greenland, while caustic soda is manufactured somewhat largely in that city and elsewhere, though the main supply is still obtained by importation. Soda for baking-powders is also extensively produced in American factories. One San Francisco concern is manufacturing soda for this purpose from the native salts of Nevada, while great progress is making in the production of carbonate, bicarbonate, and other salts of soda from these western alkaline deposits.

These deposits are perhaps destined in the future to become the world's great source of soda. In the rainless region of the far west is a broad "alkaline belt" in many parts of which the earth is deeply impregnated with alkaline salts, principally those of soda, while there are many lakes whose waters contain a considerable percentage of soda salts, and in certain places crystallized soda occurs in thick deposits. This varies from nearly pure carbonate in some instances to chloride and sulphate in others, while the quantity is abundant beyond any possible demand. The alkaline belt lies in the least explored region of the United States, its lack of rain rendering it unfit for agriculture, while its prospectors are mainly in search of minerals, and pay little attention to its alkali beds. Yet some of these are coming into use as sources of commercial soda, and others are likely to do so with the development of railroad facilities of transportation. Up to a recent period the only natural deposits worked to any extent were those situated in the Carson Desert, Churchill Co., Nevada. Here there are two lakes, their beds evidently the craters of extinct volcanoes. The soil is saturated with soda, which is leached by the springs and streams flowing into the lakes, and, as the waters of these lakes evaporate during the summer, the soda is deposited in crystalline form. This crystalline mass, containing a considerable percentage of carbonate of soda, is collected, dried, and sent to market. Several smaller deposits in Nevada have been worked to some extent for the San Francisco market. The lakes in this region have no outlet, and all are more or less saturated with the alkaline leachings of the soil, which vary from nearly pure carbonate in some cases to sulphate and chloride in others. Large deposits of nearly pure sodium sulphate occur in Nevada near the California borderline, where the crystalline mass is said to be from 2 to 8 feet thick over an area of 100 to 200 acres.

Wyoming Territory possesses numerous small soda lakes, some of which are now worked for commercial purposes. About 13 miles nearly due south from Laramie City lie the "Union Pacific Lakes," to which a branch railroad has been extended. There are here five lakes, while the soil is everywhere impregnated with sulphate of soda. In wet years the soda in these lakes is almost fluid. In dry years, from large evaporation, it becomes solid in four of the lakes, and a saturated solution in the fifth. The soda of these lakes has been worked since 1885, over 60 tons of caustic soda being produced in that year. It being the sulphate salt, the first step in the Le Blanc process can be dispensed with, but the trouble and delay in getting rid of its abundant water largely negatives this advantage. The deposit is practically inexhaustible, it being now more than 9 feet thick over an area of more than 100 acres, and annually added to by the inflow from saturated springs. It is estimated to contain about 50,000,000 cubic feet of chemically pure sulphate of soda. The Donney Lakes, about 18 miles southwest of Laramie, comprise three lakes, covering about 520 acres. In one of these the deposit is 11 feet thick, in the others 5 to

6 feet. The Dupont Lakes in Carbon Co., Wyoming, are four in number, varying in area from 4 to 2000 acres, their waters saturated with sulphate and carbonate of soda. One of these lakes is covered by two claims, known as the New York and Philadelphia claims, the former including 160, the latter 80 acres. One bore hole, sunk 50 feet from the shore, showed a bed of 4 feet of soda; another, 230 feet out, went through 14 feet of solid soda without reaching its bottom. This is over 70 per cent. sulphate of soda. The percentage of carbonate of soda is much greater in the Dupont than in the Donney and the Union Pacific Lakes, amounting, in some of the deposits made by evaporation, to 59.24 per cent. Near Morrison, Colorado, the soil, over an area of 80 acres, is impregnated with soda salts to a depth of 52 feet. There is another large deposit near Croton Springs, Arizona, where a thick bed of the several salts of soda covers an area of several square miles. Few of these deposits have been examined with a view to their utilization, the distance from railroads and high cost of transportation rendering them unavailable at present.

As for the uses to which soda is applied, they are manifold. One of the most important of these is the glass industry, which consumes about half the soda used in the United States. In 1885 the consumption in this industry was: Soda ash, 60,050 tons; salt-cake, 23,419 tons; nitrate of soda, 2987 tons; common salt, 2323 tons—making a total of 88,779 tons. The use of salt cake or sulphate of soda in this industry has largely increased of recent years, its percentage increasing from 14 in 1880 to 28 in 1885. Another large soda-consuming industry is the soap manufacture, while soda is an important requisite in paper making, in dyeing and bleaching of cotton and woollen goods, in boiler cleaning, etc. It is used in considerable quantities in the making of baking-powders, which now replace yeast in most American kitchens. Bicarbonate or sesquicarbonate of soda is an essential element of these powders, the purpose being to develop carbonic-acid gas in the interior of the dough, a result similar to that which is attained by the use of yeast. Soda bicarbonate is also used as one of the constituents of soda-powders and seidlitz-powders. These are but a few of the uses to which the salts of soda are put. They are used also in the starch, sugar, glucose, oil refining, candle, aniline dyes, wood-pulp, earthenware and pottery, dynamite, and many other industries, the number and diversity of which are sufficient warrant for the statement made at the beginning of this article that soda is far the most important chemical product used in human industries. (C. M.)

SOILS. Soils are the results of two active and incessant terrestrial influences, the disintegration of the rock materials of the earth's surface, and the deposit in the abraded material of organic substances, the product of animal and vegetable life processes, and of the decay of dead organic matter. To the former the great bulk of all soils is due; to the latter, much of their fertility. The breaking down of the rocks is a slow but incessant process. It is effected by the agency of rains and running water, of frosts and sunshine, of atmospheric action, and other less important influences; the small rock particles thus produced and scattered through the soil being gradually reduced to a finer stage by minor influences, among them the action of plant-roots and of the small animals which burrow in the earth's surface. The influence of earthworms, ants, and other small creatures upon the constituents and conditions of the soil has of late years been shown to be considerable and important. Organic materials are deposited in the soil largely by natural processes, and to an important extent through the agency of man. These in bulk constitute but a small percentage of the soil,

but their utility is far in excess of their quantity. Many of the most important food plants feed largely upon them, and exhaust them from the soil at a rate that requires their annual restoration. Human agency assists also in the making of soils by the addition of fertilizing mineral substances, such as lime, the mineral phosphates, etc., thus adding to imperfect soils some important element of fertility, or modifying the character of the soil so as to adapt it to the production of certain crops. Through these agencies of man and other animals, and through the disintegrating processes of nature, soils of greatly varied composition are produced, their character often changing considerably within a few miles of distance, and occasionally within the limits of a single farm.

Soils, considered in reference to their degree of openness and closeness, lie between two extremes, the sandy and the clayey. Their degree of fertility, however, does not conform to this division, the sandy soils, for instance, while frequently barren, being by no means always so, since the composition of sand may vary greatly. The distinction of these two extremes is that of degree of comminution of material and retention of moisture, and of comparative permeability, rather than of fertility, the latter quality being by no means dependent on the above characteristics. Austere barrenness, as a rule, is confined to the silicious sands, and to rainless and streamless regions, there being scarcely any other condition of soil and climate that is not adapted to the free growth of plant forms. Of the sands and gravels that cover such vast spaces in the Eastern Hemisphere, the infertility is due rather to lack of rain than to native barrenness. The sands of the Sahara and of Arabia show no lack of fertility where watered by springs and wells. These vast stretches of sandy soil are paralleled in other parts of the earth by other homogeneous deposits of great extent. In Southern Russia, for instance, there is a vast tract, 200,000,000 acres in extent, of "black earth," which is of extraordinary and persistent fertility. In the highlands of Scotland and Bavaria, as also in Prussia and elsewhere, are great stretches of moorland, bearing only a nearly useless growth of heath or moss. In the United States we have similar great homogeneous surfaces, as in the alluvial bottom lands of the Mississippi, the compact, deep, widely extended soil of the prairies, the broad reaches of alkali lands in the western mountain region, the sands of New Jersey and some other localities, the vast swamp regions along the southern Atlantic coast, and other less extended instances. But as a whole, the soils of this country as of other regions are heterogeneous in distribution, depending largely upon the character of the underlying rock, and in many cases differing greatly within limited areas—clay, sand, gravel, vegetable mould, and unlike mixtures of these, occurring often in close proximity to each other.

The agencies and methods by which the hard rock surfaces are broken into fragments and ground down into soils, have been sufficiently considered in the article on AGRICULTURE, Chap. II., in this work, and we need here but consider some further aspects of the subject. There are two broad classes into which soils may be divided, the sedentary and the transported. Of these the sedentary soils, or soils in place, are those in which the materials of rock disintegration have not been moved by natural agencies, but remain where produced. They have arisen from the weathering of exposed rocks, which they still cover or lie contiguous to, and with which they are identical in composition. Such soils have usually little depth, their presence protecting the rocks which they cover from further disintegration. The inspection of the underlying rock usually gives valuable information as to their composition and agricultural

value, the mineral elements visible in it not being so readily observable in the finely comminuted soil. Soils of this character are not abundant in New-England and the regions north of the Ohio, and east of the Missouri, nor in the river valleys of the country. Here they occur only in small patches, as where the friable outcropping red sandstone of the Connecticut valley has crumbled into soil, or where trap bluffs have made soils at their bases. In the more southern and western regions, away from the river valleys, sedentary soils are the rule.

Transported soils are those in which the material has been removed to a distance from its place of origin by moving agencies, principally ice and water, and deposited elsewhere as sediment. Of these those known as drift or diluvial soils are characterized by the rounded edges and surfaces of their larger fragments, and by their lack of stratification. They embrace soils proper and collections of stones, varying in size from grains to great rock boulders, which are scattered indiscriminately through and over the soil. These soils are supposed to be the product of ice action, the work of the great glacial movement which, there is satisfactory reason to believe, took place during the glacial age of geology, affecting the whole country from the Arctic zone to about the latitude of 40°, its effects on the soil extending to southern New England, to nearly the southern boundary of Pennsylvania, and to the Ohio River, and extending from the Atlantic to the States west of the Mississippi. The whole of this region is more or less covered with the rock debris moved by the glacier, the material being as a rule transported 20 to 40 miles from its place of origin, and in some cases from 60 to 100 miles. Drift soils are often of the most diversified character, including rock materials of great variety, which have been mingled and carried in the ice flow. Of those only the hard granite and silicious rocks occur in large fragments, the softer ones being ground to powder, the fine soil and stones of varied size being often indiscriminately commingled. Drift surfaces are usually irregular and hilly, the hills being conical heaps or long ridges of mixed sand, gravel, and boulders, often of great depth. South of the boulder line is a region, occasionally of considerable width, of much finer material, and partly stratified. This is supposed to have been the mud and sand carried by the waters of the melting glacier, and deposited by the streams over a broad area farther south. The sands of southern New Jersey and Long Island may have been due to this process, as well as the fertile soil of southern Pennsylvania. Drift soils greatly vary in productiveness, in consonance with their variety of materials. The soils of New England, for instance, are lacking in fertility, while those of Pennsylvania and Ohio are of unsurpassed excellence.

Another form of the transported soil is that known as alluvial. This consists of the worn materials transported by running waters, and deposited along the course of overflowing rivers. These are always more or less stratified, the coarser materials on the bottom, the finer on top. The coarser are also deposited most abundantly along the upper reaches of the rivers, the finer farther down, impalpable mud being carried much farther than sand or gravel. Such soils occur in the valleys of streams, and in silted-up beds of old rivers, lakes, and gulfs. In the United States, much the most extensive deposit of alluvial soil is that laid down in the bottom lands of the Mississippi River and its western tributaries, the Ohio cutting too narrow a channel to leave much space for such deposits. The bottom lands of the Mississippi, covered everywhere with finely comminuted materials abraded by the river and its tributaries from the head-water and bordering regions of the streams, and deposited along the more level

lower reaches of the river, average 40 miles in breadth, and extend for a distance of 500 miles, the stream winding through them with a length of 1,100 miles. Their total area is about 32,000 square miles, much of it of great depth of soil and almost inexhaustible fertility, though comparatively little of it is yet cultivated.

Soils in which drift and alluvial are mingled with sedentary materials, have been named colluvial soils. They are distinguished by the presence in transported material of sharp-angled fragments of original rock, that have evidently not been carried far. Such soils are of comparatively small extent. Of other distinctive American soils, may be mentioned those of the prairie States, which are distinguished by the absence of trees and the great depth of their fertile material. They probably belong to the alluvial class, being produced by the gradual silting up of great, shallow lakes, which formerly may have occupied this whole region. Their productive powers seem to be increased by the processes of cultivation, and seem almost inexhaustible, many years of cereal production without manuring showing little perceptible diminution in abundance of crops. In the western borders of the prairie region fertility is diminished by the lack of rain. In respect to its rainfall, the United States may be divided into two nearly equal portions by the meridian of 100°. The region east of that meridian has a sufficient and pretty regular distribution of rain; that westward is irregularly and insufficiently supplied, except a narrow belt on the Pacific coast. Part of the latter is abundantly supplied; part of it irregularly but in fair sufficiency; while in part of it the rain is insufficient for agriculture. Much of this region is, and must remain, essentially pastoral in its uses, though through a considerable portion of it irrigation has taken the place of rainfall, and abundant crops are raised from the highly fertile soil. The specially arid region of the United States is that known as the Great Basin, a vast district with an area of about 225,000 square miles, which constitutes an elevated plateau between the Rocky and the Coast mountain ranges, which, from its rainless character and the impossibility of irrigation, must remain permanently useless in an agricultural sense. (See GREAT BASIN.)

We may conclude with a brief consideration of the several varieties of soils, and their distinctions of physical and agricultural character. Plants derive their food from the fine, and particularly from the finest particles of the soil, of which a very small percentage is available for plant-food at any one time. But the larger particles are equally useful, from their aid in keeping the soil open and permeable, while through their gradual disintegration they furnish new plant-food. Gravelly soils are so named from their abundance of small stones or gravel. Such soils may be poor or rich, in conformity with the character of their fine material, and also the composition of their gravels. If there be many pebbles of felspar, the soil will probably be well supplied with alkali; if of limestone, with lime; if of quartz, the soil will be poor. Sandy soils are those which contain 90 per cent. or more of sand, or small grains of rock of any kind. If the sand be composed of nearly pure quartz grains, the soil will be barren, but generally other minerals, such as felspar and mica, are present, and iron compounds exist where the sand is red or yellow. These minerals, by their decomposition, often give considerable fertility. The green-sand of New Jersey is used as a fertilizing material, it containing much organic substance. The term sandy soil is, therefore, very indefinite as regards fertility. Coarse sandy soils are usually unprofitable, but fine sand is often agriculturally valuable.

Clayey soils, physically considered, stand at the

opposite extreme from sand. They are those in which clay or impalpable materials predominate. The extreme fineness and close compacting of their substance render them very retentive of water, which sandy soil is almost incapable of retaining, and when dry they break into cracks and rifts through shrinkage. Soils may be clayey in texture without being composed of clay, since other substances than kaolin and the other clay compounds may give them adhesiveness and impermeability.

Intermediate between clayey and sandy lie the loamy soils, or soils composed of a mixture of sand and clay, or of coarse and impalpable substances. These are less tenacious than clay, more so than sand, and exist in many degrees between sand and clay, being known by the various titles of clay loam, loam, sandy loam, light sand loam, etc. The physical condition of these soils is that best suited to ordinary agriculture. Calcareous or lime soils are those that contain carbonate of lime in predominating quantity. They are not uncommon in Europe, but are rare in the United States, and scarcely occur at all in the Northern and Middle States. In general, the lime is subordinate to sand or clay, yielding calcareous sands, calcareous clays, or calcareous loams. Marls are composed of a mixture of clayey material with finely divided carbonate of lime. The green-sand of New Jersey is of this character. Of other soils may be named peat or swamp muck, composed of humus arising from the decay of vegetable substance in bogs and marshes. Where much organic matter has decayed out of water, as leaves of trees, grasses, etc., it forms a soil of vegetable mould. Ochrey or ferruginous soils are those containing much iron oxide or silicate. They are yellow, red, or brown in color. The portion of the soil usually wrought is that near the surface, and which is directly exposed to sunlight, rain, and atmospheric influences, and which contains humus from decaying roots, etc. Beneath it lies the subsoil, unmodified by these agencies, yet often containing much fertilizing material. This is frequently brought to the surface in the deep plowing of recent farming. Under this, in certain regions, is a dense, almost impenetrable, crust known as "hard pan." It is composed of clay or gravel cemented by iron or other compacting material, and may be considered as soil on its way back to become rock. Hard pan often forms the bottom of marshes or peat-swamps, in a thin impermeable layer beneath which may lie porous soils. (C. M.)

SOLA, ABRAHAM DE (1825-1882), rabbi, was born in London, Sept. 18, 1825. He was carefully trained in Hebrew learning, and in 1847 accepted a call to a Portuguese-Hebrew congregation in Montreal. Here he became prominent as a pulpit orator and advocate of orthodox Judaism. In 1853 he was made professor of Hebrew in McGill University, and afterward lectured there on Spanish literature. He also taught Hebrew in the Presbyterian College of Montreal, and was president of the Natural History Society of that city. He died while on a visit to New York City, June 5, 1882. He published a *History of the Jews of Persia* (1818); *Scripture Zoology* (1848); *Jewish Calendar System* (1854); *Sanitary Institutions of the Hebrews* (1860); *Shabbatui Levi, the False Messiah* (1869); *History of the Jews of Poland* (1870); *History of the Jews of France* (1871).

SOLOMON, and the Book of PROVERBS. The author of the article on SOLOMON in the See Vol. XXII. ENCYCLOPÆDIA BRITANNICA speaks of p. 251 (p. 265 "the many floating and fragmentary Am. Rep.). notes of various dates that have found a place in the account of his reign in the Books of Kings." Dr. A. B. Davidson in the article on PROVERBS, in the same work, says of the times of Solomon, that "life in the civil sense began in this age.

. . . Then the tribes were consolidated into one community, the state rose into existence." One who holds that there was properly no Israelitish nation, and no united Israel, until the time of Solomon, and that the institutions described in the Pentateuch mostly originated during the successive centuries that followed Solomon, must necessarily hold that the history of Solomon, as given in the Bible, is disjointed and largely inconsistent with fact. But if we accept the statements of the Bible to the effect that Israel had been a people from the times of Abraham, and a nation from the times of Moses; that Solomon received from his ancestors the law that Moses wrote, the ark and tabernacle that Moses made, and the institutions that Moses founded; that the building of the temple was a fulfilment—up to that date, the most notable fulfilment—of the ancient promise to give Israel rest; that the religious ordinances and seasons of the Pentateuch, including the three great annual festivals, were observed in connection with the temple, in Solomon's time, then "the account of his reign in the Books of Kings" is consistent and intelligible. It presents itself as having been compiled from different sources, and as a record of only a part of the events of the times, but it is a coherent record.

On the whole, the accounts in Kings and Chronicles attribute to Solomon neither the highest type of moral and spiritual character nor the highest type of statesmanship. It is not likely, however, that his reputation as a builder, a man of culture, successful in commerce, and living magnificently, will ever greatly dwindle.

In the article PALMYRA, in the ENCYCLOPÆDIA BRITANNICA, Prof. W. Robertson Smith adduces considerations to show that the traditional reading of 1 Ki. ix. 18 is incorrect, that this passage does not mention Tadmor in the wilderness, and that the author of 2 Chron. viii. 4 is therefore mistaken in his reading of the passage in Kings. If these were conclusive they would go to show that Solomon's overland commerce was less extensive than has commonly been supposed. But they are not conclusive; they prove at most that the alleged understanding of the matter might be possible, if there were evidence in support of it, but they do not furnish the required evidence. For Solomon's purposes, the commercial route through Palmyra would not be a rival to that by the Red Sea, provided he controlled both routes, as the Biblical narratives certainly represent that he did. The opinion that Solomon founded Palmyra is more tenable than the conjecture that certain unknown Arabs founded it at some unknown later time.

For the times of Solomon in their relations to the rest of the history, see ISRAEL.

The Biblical accounts represent that there was a revival of literary culture in Israel in the reign of David, and that Solomon was especially distinguished in certain departments of science and letters. It is in accord with this that the Book of Canticles and most of Proverbs have been commonly attributed to him. In proof that Canticles is not an "unfriendly picture of Solomon," drawn by some northern Israelite, but is probably a genuine work of Solomon himself, see CANTICLES in this work. As to the Book of Proverbs, no one disputes that it contains some genuine sayings of Solomon. From the titles at the beginning of the book, and in x. 1 and xxv. 1, it is most natural to understand that the sayings here found are prevailingly (perhaps not exclusively) Solomonic; that chaps. i.-xxiv. are an earlier collection, including previous smaller collections; and that chaps. xxv.-xxxix. are a supplementary collection of Solomonic proverbs, made in the days of Hezekiah. In extreme opposition to this, certain scholars hold the proverb-collections to be among the latest of the

post-exilic books. Differing from both these views, Dr. Davidson's article on this book holds that probably chaps. xxv.-xxix. are the oldest part of the book, and are a genuine collection made in Hezekiah's time by combining several earlier collections; that chaps. i.-ix were written "not very long anterior to the destruction of Jerusalem, possibly about a century after the men of Hezekiah made their collection;" that chaps. x.-xxii. 16, and the two smaller collections, xxii. 17-xxiv. are likewise, perhaps, pre exilic; and that xxx. and xxxi. are very likely post-exilic.

There is no reason directly connected with the question of the divine authority of the Scriptures to prevent our accepting views like these, provided they are well grounded; but the question whether they are well grounded is itself important. The grounds urged for them are such as the following: "The headings cannot be absolutely relied upon." It is sufficient to reply that there is no proof that the headings in Proverbs are unreliable. Dr. Davidson regards the heading in xxv. 1 as trustworthy, and observes that it presupposes the collection of proverbs in the previous chapters. Hence he infers that the heading cannot have been written by the men of Hezekiah who made the collection, but must have been added by the later editor who put the several collections together. The alternative inference is quite as probable, namely, that the heading was written by the men who made the collection, and that the collections in the previous chapters had then already been made. But it is said of these men: "They can hardly have been acquainted with x.-xxii., otherwise their code would not have contained so many duplicates of maxims in that collection." But, if these duplicated maxims prove that the first of the two collections was written later than the second, they equally prove that the second was written later than the first; that is to say, they prove nothing.

It is said that the general preface, at the opening of the book, "extends at least to xxii. 16; but . . . a new inscription 'The Proverbs of Solomon,' heads x. This implies that i.-ix. were not considered Solomonic." But this implication is not distinct enough to compel recognition from most minds. It is said that "the conjecture that Solomon himself put forth any collection of his proverbs has little to support it." But the conjecture that he did not put forth such a collection has still less to support it. It is argued that neither the whole nor any part of Prov. x.-xxii. 16 can have been collected in its present shape by any person who was the author of any great number of the proverbs contained in it, because the collection is confused, one of the proverbs being repeated, while there are several instances in which one member of a proverb also does duty in another proverb. But it is difficult to see that repetitions or confused arrangement are impossible for an author of proverbs any more than for any other man.

It is further said, in regard to Solomon: "Such maxims cannot be regarded as wholly or even in a very large degree the production of an individual mind. . . . Though the stream of wisdom began to flow in his day, its beginnings were then comparatively small; as the centuries advanced it gathered volume" But the Book of Proverbs is not a very extensive work, if compared, for example, with *Poor Richard's Almanac*, or with such a collection as might be made of the pithy sayings of Matthew Henry or John Bunyan. Why should not most of the proverbs have come from Solomon himself? Why should it require centuries to accumulate the rest?

It is also argued that the "universalistic ideas of God and providence," so characteristic of the Prov-

erbs, cannot have existed in Israel till the Israelites had come in "contact with the great empires of the world." But wide ideas of God and providence do not necessarily depend on contact with great political powers; and if they did, Israel's contact with these powers was as real at certain earlier periods as during the later invasions by Assyria and Babylonia.

The alleged proofs that Prov. xxx. is post-exilic are its likeness to Job xxviii. and Ecclesiastes, and the suggestion that ver. 6 may perhaps contain an allusion to "canonical writings." The proof that xxxi. is of late origin is that some of the products mentioned in this chapter are not mentioned in Ezek. xxvii. 17, and also that the alphabetic arrangement of the verses, beginning with ver. 10, is regarded as a late style of writing. Of course, none of these considerations have any decided strength.

On the whole, it is safe to affirm these two things in regard to the Book of Proverbs: Its contents are mainly Solomonic; the strongest evidence as to when the collections were made is that found in the titles, the order of the parts, and the presumption that a man like Solomon would have something to do with editing his own published works. (w. j. b.)

SOPHOCLES, EVANGELINUS ANOSTOLIDES (1807-1883), classicist, was born near Mount Pelion, in Thessaly, March 8, 1807. He was educated in the convent on Mount Sinai, but afterward came under the influence of American missionaries at Athens. In 1829 he came to Massachusetts, entered Amherst College, and afterward taught Greek at Hartford and New Haven. In 1840 he was made a tutor at Harvard College, in 1849 assistant professor of Greek, and in 1860 professor of modern and Byzantine Greek. He was an excellent teacher, and rendered valuable service to scholarship in the United States by his grammars both of ancient and modern Greek, and various text-books. His most important work is his *Greek Lexicon of the Roman and Byzantine Periods* (Boston, 1870). In his modest apartments at Harvard he lived like a hermit, seeming to the youth of the Western Republic himself a picturesque fragment of the ancient civilization he strove to elucidate. He died at Cambridge, Dec. 17, 1883.

SORGHUM. See AGRICULTURE, Chap. V. 4.

SOULÉ, PIERRE (1801-1870), senator, was born at Castillon, France, in 1801. His father had been a lieutenant-general in the French republican army. The son was educated at Toulouse and Bordeaux. While at college in the latter city he joined in a conspiracy against the Bourbon government. On its discovery he fled, and concealed himself in the guise of a shepherd for a year. Going to Paris, he became a journalist, and soon was prosecuted and imprisoned for an attack on the government. He escaped to England, thence went to the West Indies, and soon removed to the United States. In 1825 he began his career at New Orleans, and was soon prominent as a lawyer and politician. He was sent to the U. S. senate in 1847, and there advocated extreme Southern views. In 1853 he was sent as U. S. minister to Spain, where his conduct was marked throughout with insolence to the government and his fellow-diplomats. He fought a duel with the French ambassador, encouraged a revolutionary outbreak, withheld a trade-treaty which had been negotiated, and joined in the Ostend manifesto which declared the purpose of the U. S. government to take Cuba, if not by purchase, then by force. He returned in 1855, and was interested in the Tehuantepec canal project. Though he opposed the secession craze in 1860, he went with his State, and in 1861 was a Confederate agent in Europe. In 1862 he was captured in New Orleans by the Union troops, and was sent to Fort Lafayette. Being released on condition of leaving the country,

he went to France, but in 1869 he returned. He died at New Orleans March 16, 1870.

SOUND. See ACOUSTICS.

SOUTHARD, HENRY (1749-1842), patriot and congressman, born on Long Island, N. Y., October, 1749, his father's name being Southworth. When he was but 7 years old, his father removed to Baskingridge, N. J., where, after receiving an ordinary school education, Henry worked on the home farm and as a day-laborer, till he earned money enough to purchase a farm for himself. An excellent memory and sound practical judgment fitted him for public work. He was active as a patriot during the Revolutionary war, was for nine years a member of the State legislature, and sat in Congress from 1801 to 1811, and from 1815 to 1821. In the latter year he met as a member of a joint committee of the U. S. senate, his son Samuel Lewis, and voted with him on the Missouri Compromise. Till he had passed his ninetieth year he neither wore glasses nor used a staff. He died at Baskingridge in June, 1842.

His son, SAMUEL LEWIS SOUTHARD (1787-1842), judge and senator, was born at Baskingridge, June 9, 1787. He received a sound education and graduated at Princeton College in 1804. After teaching school in his native State, he went to Virginia as tutor in the family of John Taliaferro, during his residence with whom he studied law, and was admitted to the Virginia bar. In 1811 he settled as a lawyer at Hemington, N. J., and in 1814 was appointed by the legislature law-reporter. In 1815 he became associate-judge of the supreme court of the State, was a presidential elector in 1820, and United States senator from 1821 to 1823, during a considerable part of which time he was *pro tem.* president of that body. In 1823 he was appointed by Pres. Monroe secretary of the navy, and held the office till 1829, acting also as secretary of the treasury from March to July, 1825, and for a short time as secretary of war. Immediately on his giving up the portfolio of the navy he was chosen attorney-general of New Jersey, and, in 1832, governor of the State. In 1833 he was again returned to the U. S. senate, and on Pres. Harrison's death, in 1841, he became for a second time president *pro tem.* of that body. In 1822 he was made a trustee of Princeton, and LL. D. by the University of Pennsylvania in 1833. He died at Fredericksburg, Va., June 26, 1842. His publications comprise, *Reports of the Supreme Court of New Jersey, 1816-1820* (2 vols., 1819-20), a *Centennial Address* (1832); and a *Discourse on William Wirt*. His son, SAMUEL LEWIS SOUTHARD (1819-1859), was born at Trenton, N. J., in 1819, graduated at Princeton, 1836, took orders in the Protestant Episcopal Church, and was author of *The Mystery of Godliness* (1848), and other theological and miscellaneous publications.

SOUTH BEND, a city of Indiana, county seat of St. Joseph Co., is on St. Joseph river, and on the Lake Shore and Michigan Southern Railroad and the Chicago and Lake Huron Railroad, 85 miles E. of Chicago. It has a fine court-house, 3 national banks, a savings bank, 20 churches, a high school, St. Joseph Academy, St. Mary's Academy, and the University of Notre Dame. Three daily and six weekly newspapers are published here. The manufactures comprise agricultural implements and machinery, wagons, furniture, paper, woollen goods, etc. Its population in 1880 was 13,280, having almost doubled in ten years.

SOUTHGATE, HORATIO, missionary bishop, was born at Portland, Maine, July 5, 1812. After graduating at Bowdoin College, 1832, he spent two years at Andover, but entered the Episcopal Church, and was ordained deacon at Boston, 1835. The Foreign Committee of the Board of Missions sent him abroad in April, 1836, to investigate the condition of Moham-

edanism in Turkey and Persia. After three years' absence he returned, and was ordained priest in New York, Oct. 3, 1839. The next year he was sent back as missionary at Constantinople and delegate to the Oriental churches, remaining four years. From these experiences came his first books, *Narrative of a Tour through Armenia, Kurdistan, Persia, and Mesopotamia* (2 vols., 1840), and *Narrative of a Visit to the Syrian (Jacobite) Church of Mesopotamia* (1844). On Oct. 26, 1844, he was consecrated in Philadelphia as missionary bishop for the dominions and dependencies of Turkey. [This was the only case in which the American Episcopal Church sent a bishop to lands having native clergy of that order, and it was afterward regarded as a step of doubtful wisdom.] In 1849 Dr. Southgate came home and offered his resignation of the office, which the House of Bishops accepted in October, 1850. He published, in Greek, at Constantinople, *A Treatise on the Antiquity, Doctrine, Ministry, and Worship of the Anglican Church*, 1849. He declined the bishopric of California, 1850, and that of Hayti twenty years later. He organized St. Luke's Church, Portland, Maine (now the cathedral), 1851, was rector of the Advent, Boston, 1852-58, and of Zion, New York, 1859-72. Since then he has lived at Ravenswood, L. I. His later books are, *The War in the East* (1855); *Pastoral Sermons* (1859); and *The Cross above the Crescent* (1877).

SOUTH MOUNTAIN AND ANTIETAM. These battles were fought on Sept. 14 and 17, 1862, between the Union forces under Gen. McClellan and the Confederates under Gen. Lee, near the village of Sharpsburg, on the banks of the Antietam Creek, Maryland. After defeating the Union Gen. Pope in the second battle of Bull Run, Aug. 30, 1862, Gen. Lee in the beginning of September crossed the Potomac into Maryland, with the immediate objects of gaining over that State to the Confederacy and capturing Washington and Baltimore. Pres. Lincoln instantly called on Gen. McClellan (who was then in Washington) to take command of the Army of the Potomac, with which Pope's forces had been merged, and the general forthwith set his troops in motion to meet the inroad. On his arrival on the 12th at Frederick, which Lee had left three days previously, he came into possession of the latter's plan of campaign, which, with the view of leaving no enemies in his rear, comprised an order for Jackson to recross the Potomac, capture the forces at Martinsburg, and co-operate in the capture of those at Harper's Ferry; for McLaws to march on Harper's Ferry; and for Longstreet to halt with the trains at Boonesboro'. Walker was to invest Harper's Ferry from the Maryland side, while D. H. Hill's division was to form the rear-guard. On learning Lee's plans, McClellan set about a movement to pass his army through Turner's and Crampton's Gaps in South Mountain, and, by interposing it between the separated divisions of Lee's force, to destroy them in detail. But McClellan was, as usual, not sufficiently prompt, and when the Union army reached the gaps it found them beset by Confederates under Longstreet, Hill, and McLaws. There was stubborn fighting all day of the 14th; in the evening the Confederates withdrew, and next morning the victorious Unionists passed through the gaps to the western side of the range. But Lee, by delaying the Union advance, had gained time to concentrate his dispersed forces and to capture Harper's Ferry, with 11,000 men and 73 guns.

When Lee withdrew his left from Turner's Gap he took up an elevated position between the Antietam and Sharpsburg. His right, under McLaws, on the capture of Harper's Ferry, came promptly into line, and on the 16th Lee had his army concentrated there to the number of 40,000 men—a force ragged, indeed, and shoeless, and reduced by strag-

glers revelling in an unwarred region; but resolute, inured to war, and confidently awaiting the contest that it knew to be decisive of the campaign, in a position chosen by its leader. McClellan's army numbered over 70,000, but the Confederate army was protected on both flanks by the Potomac, on which they rested respectively, while the Antietam flowed along its front, the ground consisting of meadows, corn-fields, and patches of forest. The creek was crossed by four bridges, all save the northernmost strongly guarded. McClellan's plan of attack was to throw his right over the unguarded bridge upon the enemy's left, and, when he had thus drawn their main force to that flank, to cross with his centre and left and fall upon the enemy's right. Toward evening Hooker led his corps across the upper bridge, but little more than a skirmish ensued till the lines rested. He had, however, developed McClellan's plans and thus given Lee time to make his dispositions to meet it. The only change he thought it necessary to make was to place Jackson's fresh troops in the position on his left. McClellan during the night sent Mansfield's corps across the creek to join Hooker and had Sumner in readiness to follow in the early morning.

The dawn of the 17th saw the two armies standing ready for a great conflict in which there could be no strategy, but which must be decided by sheer fighting. The battle began at sunrise in the woods bordering the Sharpsburg road to Hagerstown by an attack by Hooker on Jackson's position in front, which was also enfiladed by artillery from across the creek. Jackson's lines at length broke, but when Hooker attempted to follow he was met by masses of troops and artillery fire, and forced to halt. Mansfield was mortally wounded when advancing to support him, but his corps moved on. Hooker himself was severely wounded and borne from the field. Sumner's corps came next on the field, and with comparative ease drove back the half-defeated Confederate divisions, and took possession of the ground they had held around a little Dunker church. His whole line now moved forward as if to sure victory, when two divisions brought from the Confederate right wedged themselves into a gap in his lines. Sedgwick's division, which formed the right of the line, was flanked on its left and driven out of the woods across the clearing into the eastern woods. The Confederates, satisfied with this, failed to pursue farther but retired to their position. Fighting of a similar character went on all forenoon. One striking episode was a race between a New Hampshire and Confederate regiment for the occupation of a commanding piece of ground, the two running in parallel lines and firing at each other as they ran. The New Hampshire men won the prize. Franklin did not participate in the fight till noon, having just then arrived from the southern (Crampton's) gap of South Mountain, and was at once despatched across the creek to aid Hooker. He came just in time to check an advance of fresh troops from the Confederate right.

But while both parties thus strove gallantly on the Union right, Porter and Burnside, in command of the centre and left, remained unaccountably supine. So early as 8 A. M., the latter had been ordered to carry the bridge on his front and assail the Confederate right. Though the command was more than once and urgently repeated, he did not succeed in crossing till 1 P. M., and, even after effecting this, two more hours were lost before he carried the ridge commanding Sharpsburg and captured the enemy's battery there. Then A. P. Hill's division, 2000 strong—Lee's last reserve—came up from Harper's Ferry and, uniting with the Confederate forces on the left, retook the battery and drove Burnside from the height. This concluded the battle. The strug-

gle ceased, not because a victory had been won, or because night had fallen, but because both sides had suffered so severely that neither was disposed to renew it. The reason why the Unionists, with their vast superiority in numbers, failed to carry a great victory is self-evident. The corps commanders, or, rather, some of them, did not act in concert, and the attack was made in dribbles. The Union preponderance in force was thus neutralized. At any one point Lee was able to meet an attack with a force as strong as that making it.

Gen. McClellan reported his entire loss at 12,469, of whom 2010 were killed; Lee's may be set down at 13,533. McClellan says "about 2700 of the enemy's dead were counted and buried upon the battle-field." Three Confederate generals were killed and 8 wounded. Of regimental and brigade losses may be cited that of the 16th Connecticut (which here saw service for the first time), which went in 940 strong and came out 508, and that of McLaws' Confederate brigade, which went in with 1150 men and came out with 596, losing 5 out of its 6 regimental commanders. Hay's brigade lost even more in proportion. McClellan reported over 6000 prisoners taken, 13 guns, and 39 flags, while he himself had not lost a gun or a color.

Sept. 18th, there was no fighting, and when, on the 19th, McClellan prepared to renew the struggle he found that Lee had left the field and withdrawn into Virginia by the ford at Shepherdstown.

(J. H.)

SPALDING, MARTIN JOHN (1810-1872), Roman Catholic archbishop, was born in Marion County, Ky., May 23, 1810. He graduated at St. Mary's College, Lebanon, Ky., in 1826, studied theology, and went to the Propaganda College in Rome. He was ordained priest in 1834, and was made pastor of the cathedral at Bardstown. In 1828 he took charge of St. Joseph's theological seminary there, and in 1840 he removed to Lexington, Ky., but in the next year returned to his original post. In 1848 he was made coadjutor to Bishop Flaget of Louisville, and in 1850 succeeded to the bishopric. While coadjutor he introduced some religious orders, and while bishop built a handsome cathedral at Louisville. He attended the plenary council at Baltimore in 1852. In 1864 he was promoted to be archbishop of Baltimore, and he died there, Feb. 7, 1872. Archbishop Spalding was noted for his literary activity. In 1835 he began to publish the *Catholic Advocate* and was connected with it till 1858, when he established the *Louisville Guardian*. His review of Dr. Merle D'Anbigne's *History of the Reformation*, issued in 1844, was enlarged into a *History of the Protestant Reformation* (2 vols., 1860). He also published *Early Catholic Missions in Kentucky* (1846); *Evidences of Catholicity* (1847); *Life of Bishop Flaget* (1852); *Papal Infallibility* (1870).

SPARKS, JARED (1789-1866), noted for his services to American history, was born at Willington, Conn., May 10, 1789. After getting a common school education he worked on a farm, then learned carpentry, and at times taught school. His eagerness to learn procured him friends, especially among the ministers, who helped him forward in pursuit of knowledge. At the age of 20 he entered Phillips' Exeter Academy, and two years later went to Harvard College. Though his student-course was interrupted by teaching in Maryland, where he also saw service in the militia against the British invasion, he graduated in 1815. Again he taught school at Lancaster, Mass., and then returned to Harvard to study theology. In 1817 the college authorities made him a tutor in mathematics and natural philosophy, and he also assisted in editing the *North American Review*. In May, 1819, being now thirty years of age, he was ordained pastor of a Unitarian church in Baltimore,

Dr. Channing preaching on the occasion. An earnest defender of Unitarianism, he engaged in animated controversies with Dr. Wyatt of the Episcopal Church and Dr. Samuel Miller of the Presbyterian Church. In 1821 he was chosen chaplain of Congress, but two years later ill-health compelled him to abandon preaching. After travelling through the Western States he settled in Boston, and there became editor and proprietor of the *North American Review*. While in Baltimore he had been industrious in writing, editing, and compiling, but rather on religious topics. He now turned to American biography and history, his first publication being a *Life of John Ledgard* (1828), though he had already been working on his edition of the *Writings of Washington*. This work, as finally published in 12 volumes (1831-37), contained both official and private papers, with notes, illustrations, and biography. Its value was attested both by elaborate reviews and by its republication in abridged form in England, France, and Germany. Its accuracy has been assailed, but on insufficient grounds. It must be understood, however, that Sparks did in some instances modify not only the spelling but the language of the original further than would now be thought proper. Before this work had appeared, Congress had authorized Sparks to edit the *Diplomatic Correspondence of the American Revolution*, which appeared in 1829-30 in 12 volumes. Another valuable work was his *Life of Gouverneur Morris* (3 vols., 1832). After this, calling to his aid a number of literary associates, he projected his *Library of American Biography*. The first series of 10 volumes appeared between 1834 and 1838; the second, of 15, between 1844 and 1848. Of the sixty lives here presented Sparks wrote eight: Ethan Allen, Benedict Arnold, Father Marquette, De la Salle, Count Pulaski, John Ribault, and Gen. Charles Lee. Meantime his edition of *The Works of Benjamin Franklin* (10 vols., 1840) had taken its place by the side of his *Writings of Washington*. Over 250 letters contained in it were printed for the first time. Another companion work was *The Correspondence of the American Revolution* (1854), which contains the letters addressed to Washington by nearly two hundred of his eminent contemporaries. Dr. Sparks had been in 1839 made McLean professor of history in Harvard College, and in 1849 was made president of that institution. In 1853 he was compelled to resign on account of ill-health. He continued to reside at Cambridge and was engaged on a *History of the American Revolution* until his death, March 14, 1866. Rev. George E. Ellis, D.D., published his *Memoir* in 1869. His library and manuscripts are in possession of Harvard University.

SPEAR, SAMUEL THAYER, Presbyterian editor and author, was born at Ballston Spa, N. Y., March 4, 1812. He studied both medicine and theology, and was ordained in 1835 pastor of a Presbyterian church at Lansingburg, N. Y. In 1843 he removed to Brooklyn, where he held a pastorate until 1870. In 1887, on account of infirmities of age, he retired from the Brooklyn Presbytery. He was for many years one of the editors of the *Independent*, and he also contributed to various reviews. Among his works are *Family Power; Church and State; The Bible Heaven*.

SPENCE, HENRY DONALD MAURICE, English clergyman, was born in Pall Mall, London, in 1836. He was educated at Westminster School and at Corpus Christi College, Cambridge, graduating in 1864. He was made professor of modern literature in St. David's College, Lampeter, in 1865, and rector of St. Mary de Crypt, Gloucester, in 1870. He also became principal of the Theological School of Gloucester and canon of the cathedral in 1875. He was made rural dean of St. Paneras in 1877. He has been noted for his exegetical labors. With Dean Howson he prepared a *Commentary on the Acts of the*

Apostles. He assisted in Bishop Ellicott's *Commentaries*, and was editor of the *Pulpit Commentary on the Old and New Testaments*. He has also prepared some treatises on the *Talmud*.

SPENCER, ANDROSE (1765-1848), jurist, was born at Salisbury, Conn., Dec. 13, 1765. He graduated from Harvard University in 1783, studied law, and began practice at Hudson, N. Y., where he was appointed city clerk in 1786. In 1793 he represented Columbia County in the State assembly, and from 1795 to 1802 he was a State senator. In 1796 he was appointed assistant attorney-general of Columbia and Rensselaer counties, and in 1802 was made attorney-general of the State. In 1804 he was raised to the bench of the supreme court, and from 1819 till 1823 was chief justice, being also meantime a member of the State constitutional convention of 1821. On resuming the practice of law, in Albany, he held various local offices, including that of mayor of the city from 1824 to 1826. Elected to Congress in 1829, he used his efforts to arrest the injustice of the government toward the Cherokees. In 1839 he retired to Lyons, N. Y., where he occupied himself mainly with agricultural pursuits. In 1844 he was president of the Whig national convention at Baltimore. He was author of a measure for abolishing capital punishment in all cases except treason and murder, and of another authorizing the erection of a State prison near New York City. He died at Lyons, March 13, 1848. The degree of LL. D. had been conferred on him both by the University of Pennsylvania and by Harvard College.

His son, JOHN CANFIELD SPENCER (1788-1855), jurist, was born in Hudson, N. Y., Jan. 8, 1788. He graduated at Union College in 1806, and in 1807 became private secretary of Gov. Tompkins. In 1809 he was admitted to the bar at Canandaigua, and in 1811 became master in chancery. He was appointed in 1813 judge-advocate-general in the army on the northern frontier, and in 1815 assistant attorney-general for Western New York. From 1817 to 1819 he represented his district in Congress; in 1820-21 he was a member of the State assembly, in the former year serving as speaker. From 1824 to 1828 he was a State senator, serving in 1827 as a member of a board for the revision of the statutes of New York. He was appointed special attorney-general to prosecute the murderers of William Morgan (see ANTI-MASONRY), but resigned in May, 1830. From 1839 to 1841 he was secretary of state and superintendent of common schools. In October, 1841, he was appointed secretary of war under Pres. Tyler, and in March, 1843, was transferred to the treasury department. He resigned office in May, 1844, owing to his opposition to the annexation of Texas. He then returned to the practice of his profession. He served on many State commissions. New York was largely indebted to him for the organization of its asylum for idiots and the improvement of its common school system. From his *alma mater*, Union College, of which he was made a regent in 1840, he received, in 1849, the degree of LL. D. In 1838, he edited, with a preface and notes, De Toqueville's *Democracy in America*. He died in Albany, May 18, 1855. A painful and deplorable event in his family cannot be omitted. While he was secretary of war his son was a midshipman on the naval school-ship Somers, commanded by Capt. A. S. Mackenzie. While off the coast of Africa the midshipman headed a mutiny, but the mutineers were overpowered and brought to trial before a council of officers. In accordance with their sentence Spencer and two others were hanged at the yard-arm, Dec. 1, 1842. Capt. Mackenzie's conduct was subsequently approved by a board of inquiry.

SPENCER, HERBERT, an eminent English philosopher, whose system, based on the facts and theoret-

ical views of modern science, is still in process of development and publication. Spencer was born on April 27, 1820, at Derby, England. His father was a teacher of mathematics at that place, and a man of wide culture and marked character, and by his frequent discussions on radical social questions with his brothers, men of the same type, did much to develop the growing spirit of inquiry in his son. The tendency to scientific study in the boy was early shown in a fondness for keeping insects and watching their transformations, and for years the seeking and rearing of caterpillars, and the catching, pressing, and drawing of winged insects were his regular occupations. He assisted his father also in physical experiments. At the age of 13 he was sent to study with his uncle, Rev. Thomas Spencer, rector of the parish of Hinton. Here he remained for three years, making special progress in mathematics. Returning home he studied perspective with his father, and at the age of 17 was articled to a civil engineer, and was employed on the London and Birmingham Railway. In 1841 he returned home and spent two years in study, during which he collected botanical specimens, practised drawing and modelling, and showed strong inventive inclinations, manifested by improvements in the arts of watchmaking, type manufacture, etc. In 1843, after some attempts to obtain literary employment in London, he returned to engineering labors. But the railroad-building mania which had long prevailed suddenly abated, and the demand for engineers fell off.

Spencer's earliest essay in literature was in the form of professional papers contributed to the *Civil Engineer and Artisan's Journal*; but his career in this direction fairly began in a series of letters "On the Proper Sphere of Government," which appeared in the *Nonconformist* in 1842. The influence of the debates to which he had listened in his boyhood, and his own reflections on similar subjects, had given him decided and radical opinions on the nature and limitations of civil authority, which were indicated in these articles. His theory was that the governmental function should be limited to the protection of life, property, and order, the settlement of the general relations of society being left to individual social action. These letters were reprinted in pamphlet form, and constituted the basis of his later published views on the same subject, in which he has persistently advocated the contraction of the sphere of government and the leaving of the principal questions of social science and political economy to outwork themselves under the influence of natural law and without governmental interference. He believes that all wrongs will right themselves if left alone, and that political tinkering but checks the growth of true remedial influences.

Spencer, soon after ceasing the practice of his profession, took up his residence in London, and from 1848 to 1852 was engaged in literary work on the *Economist*, the *Westminster Review*, and the *Edinburgh Review*. At the house of the editor of the *Westminster* he met G. H. Lewes and Miss Evans ("George Eliot"), both of whom became his life-long friends. In 1851 appeared his first important work, *Social Statics, or the Conditions Essential to Human Happiness Specified and the First Developed*. This remarkable essay advocates a theory of society widely different from any prevailing one. It is full of radical and original views, and, while following the line of argument of his pamphlet of 1842, is a far more complete and well-digested study of social science. It is still widely popular, especially in America, and though it does not fully represent the author's later views, and is probably impracticable in many of its suggestions, it remains a most valuable text-book of democratic political philosophy.

In 1855 appeared from his pen another work of great originality and value, *The Principles of Psychology*, a philosophical endeavor to analyze the relations between mind and matter, in which he first showed his strong inclination to the hypothesis of evolution. His thoughts had been led in this direction by his studies of social law, his writings on which are full of evolutionary conceptions. As his views took a wider range than the theory of society, he began to look upon the whole development of nature from an evolutionary stand-point, and gradually to organize in his mind that philosophy of evolution which it has been the work of all his later life to develop. According to his view old cosmological and scientific ideas were giving way and others taking their place, and it was evident that science must be reconstructed on a broader and more general basis than had satisfied the minds of preceding thinkers. The idea of the unity of nature and the interdependence of the sciences was steadily growing, and several writers had advocated the developmental hypothesis as applied to the world of animals. The mind of Spencer was full of this new philosophy, which shows its influence in everything he wrote. The period from 1850 to 1860 was with him one of great mental activity, during which he produced numerous review articles in addition to his published volumes. Among these were essays on "The Philosophy of Style;" "Manners and Fashion;" "Progress, its Law and Cause;" "The Development Hypothesis;" "The Theory of Population," "The Genesis of Science," "The Nebular Hypothesis," etc. These papers have been republished in the United States in several volumes, entitled *Illustrations of Universal Progress; Essays, Moral, Political, and Aesthetic; Education: Intellectual, Moral, and Physical; and Recent Discussions*. They all show the evolutionary tendency of his thoughts, which were steadily advancing to the conception of evolution as a universal law and the sole principle of development in the universe. In his *Principles of Psychology* he dealt with the mind in all its manifestations as a product of development, holding that as the body was evolved by insensible stages from the germ to the complex organism, so was the mind. He took the ground that the mental faculties have gradually developed through the whole range of animal life, under the influence of experience and the long-continued moulding of environing nature. This was the first attempt to apply the theory of evolution to psychological phenomena. Spencer's step forward was a bold one, which met with but little acceptance from zoölogists, and was decried by the world at large. The doctrine has won a much wider audience since then, however, Spencer's views having been adopted by several succeeding writers on psychology, while many students consider the *Principles of Psychology*, as finally revised, his greatest work.

By 1858 Spencer had completed his mental study of the principle of evolution as applied to the phenomena of nature, and had fully outworked in his thoughts the conception that evolution is a universal process, dependent on the laws of matter and force, and affecting and controlling all that takes place in nature, from the genesis of the atom to that of the human soul. In this year appeared his treatise on *The Nebular Hypothesis*, and while writing it his views of evolution unfolded till it expanded in his mind to a universal law, while all branches of knowledge appeared to him to be mutually dependent, and to be underlain by this single principle. These views were not reached, like those of Darwin, through original scientific observation. Spencer's early tendency to scientific study made but little progress, and he did not become a specialist in any branch of science. Yet through persistent reading he became

deeply versed in the general facts and philosophy of the sciences, the biological branches in particular, and stored his mind with a much greater mass of data than he could have gained by original observation.

This course of wide study and independent thought next led to the resolution of developing a new system of philosophy, with the principle of evolution as its underlying basis and the discoveries of modern science as its supporting walls and columns. In 1859 he drew up in detail the plan of a series of works in which his philosophical system was to be embodied. This plan embraced ten volumes, to the completion of which he proposed to devote twenty years. It included studies of the principles of nature considered generally, and in their special application to the phenomena of life, of the mind, of society, and of ethics, the whole subject being elaborated at this early period in the author's thoughts, divided into topics, and projected in the prospectus published in 1860 almost precisely as it has been carried out in his subsequent works. He saw it all at a glance. It has taken half a lifetime to explain it to the world.

Spencer's prospectus appeared in the same year as Darwin's celebrated contribution to the evolutionary hypothesis, and the view which many entertain, that Darwin devised this hypothesis and that Spencer has but unfolded and applied it, is utterly incorrect. Darwin lays no claim to the authorship of the theory of evolution. What he did was to advance the "natural selection" hypothesis of development, a principle which has been widely adopted by scientists, and which Spencer has made much use of in his striking phrase "survival of the fittest." But his philosophy was fully developed in his mind, and partly in his writings, before Darwin had published a word on the subject, though unquestionably the hypothesis advanced by the latter author has been utilized by Spencer in the explication of his philosophical idea.

The first volume of the projected system was published in 1862, under the title of *First Principles*. It is divided into two parts: 1, "The Unknowable;" and, 2, "The Laws of the Knowable." In the first part the author maintains that human knowledge has its necessary limits, beyond which it can never advance, and that there is an unknown power which must remain forever beyond the reach of man's conceptions. To this power he gives no name and says nothing as to its possible intelligence or non-intelligence, declaring that its qualities, conditions, and relations are utterly beyond the grasp of human thought, and that speculation concerning them is and must forever remain idle. This doctrine of the "unknowable" is not an essential part of his system of philosophy proper. It has been strongly combated, and some of its conclusions seem invalidated. In the "Laws of the Knowable" Spencer lays down the basic principles of his system as applicable to the general phenomena of matter, motion, and force, declaring that in all the details of nature a law of gradual development has steadily acted, all things advancing step by step from the general to the particular, from the unconditioned to the conditioned, until, from a simple, homogeneous, uniform, and generalized state of the universe, there has arisen, through evolutionary processes and solely under the influence of natural laws and forces, a complex, heterogeneous, multiform, and specialized state. To illustrate his theory in simpler form, the original diffused and homogeneous fire-mist of the planets has become developed into spheres of extraordinary diversity of conditions, matter having lost its original uniformity, and become the wonderfully varied combination of mineral, plant, animal, intellectual, and moral conditions which now exist upon the

earth's surface. It may be said here that Spencer uses a phraseology which renders the comprehension of his system very difficult to many readers; that it is by no means presented in the simplicity of which it was susceptible.

In *The Principles of Biology* (2 vols., 1867) the evolutionary hypothesis is applied to, and illustrated by, the facts of animal and vegetable life. In 1872 appeared *The Principles of Psychology* (2 vols.), in which the evolution of mentality is reviewed and illustrated. This work is in great measure an outgrowth of his treatise of 1855, being in some respects a second edition of that work, though with much expansion and a broader grasp of the principles advocated. Continued ill-health, which has grown more disabling of recent years, together with much writing aside from his main purpose, has prevented Spencer from completing his work within the twenty years originally allotted. Of the *Principles of Sociology*, but two volumes of the requisite three have appeared; while the *Principles of Morality*, designed to be in two volumes, is at present partly represented by a treatise entitled *The Data of Ethics*. In the former of these the laws of society are sought to be deduced from the facts of social and political science, while the latter seeks to deduce the laws of human conduct from man's relations to nature and his fellows, and the scientific investigation of the growth of the sense of duty, conscience, and moral obligation.

The completion of this work has also been delayed by the general prejudice against the author's views, while yet he was obliged to make a living by his pen. As no publisher could be readily found for the work when first proposed, the author decided to become his own publisher, and to issue the work in quarterly parts by annual subscription. The volumes, as they appeared, met with strong opposition and much adverse criticism, their views of nature being so radically unlike those before prevailing as to disturb all the relations of preceding philosophical and religious thought. Spencer, however, has gradually gained a large following, and in the quarter-century that has passed since the publication of the first volume of the series, there have been remarkable changes of general opinion upon the deepest subjects of human contemplation. These changes have undoubtedly in very considerable measure been due to his philosophy, and to the scientific theories of Darwin, with the concurrent views of numerous later authors.

All that Spencer has written since the publication of his prospectus bears somewhat directly on his evolutionary system. Of these separate works, *Education: Intellectual, Moral, and Physical*, a series of reprinted papers, written in a style of unusual ease and fluency for him, has been one of the most popular. In opposition to the old system of teaching by rote, it advocates methods in which the curiosity of the pupil is excited, his observation strengthened, and his judgment constantly appealed to. This was indeed the method of teaching employed by Spencer's father, and under which his school life was passed, and he was well aware of its efficacy from boyhood. Since the appearance of his work a steady improvement has taken place in educational methods, both in England and the United States, in the direction which he points out. To this improvement his work has undoubtedly contributed, though other influential writers took part with him in advocating radical changes in education.

Of his other publications may be named *Classification of the Sciences* (1864), in which he states his reasons for dissenting from M. Comte; *Spontaneous Generation, and the Hypothesis of Physiological Units* (1870); *The Study of Sociology*, in the "International Scientific Series" (1872); and *The Coming*

Slavery (1884), a bitter attack on the increasing tendency to socialism. Much of the time taken up in writing controversial articles might have been applied to the completion of his system, leaving it to fight its own battle, on its merits or demerits, against the attacks of opponents. In addition to these he has written many magazine papers, bearing on various points of his system.

Of his separate works, however, much the most important is his *Descriptive Sociology*, which was designed to be a complete repertory of facts in relation to the structure, habits, beliefs, and other conditions of society, of all grades and characters, ancient and modern, savage, barbarous, and civilized; these facts to be arranged in tabular form, for easy comparison and reference. The plan as laid out involved immense labor, far beyond his own powers and opportunities, and he engaged three assistants, adapted by their culture and information to the work. The original plan proposed a work in 18 parts, of which several have been published, including No. 1, a descriptive sociology of the English civilization; No. 2, the extinct American civilizations; No. 3, the Negrito and Malay races; No. 4, the African races, etc. The restricted sale of the work and the great expense of the undertaking forced him to limit it to 9 numbers, extensive unpublished materials remaining in his hands. This work, covering a wide range of social facts, is of great value so far as it goes, and its completion in accordance with the original design would make it an invaluable work of reference, replete with facts of sociology nowhere else to be found in such completeness and convenience of arrangement.

It is not our purpose to attempt any critical review of the great work of Spencer's life, his system of philosophy. It has called forth a vast array of critical opinions, favorable and unfavorable. It has been proved by later investigation that some of the apposed facts on which his arguments were based are not facts at all; certain of his positions have been invalidated; several of his theories are very unlikely to be accepted, much of his reasoning has been met by equally cogent counter-reasoning. Yet all these are but attacks upon the outworks; the central citadel of his system, the evolutionary hypothesis, still stands firm. A wider and wider circle of scientists and thinkers in general have accepted the system, but it has not yet been decided what will be the eventual conclusion of cultivated mankind. The philosophical system of Herbert Spencer claims to be the most solidly based of any now in existence, as the only strictly inductive system the world possesses. Modern philosophers may be divided into two classes on national lines of separation, the several German systems being all deductive, and attending far more to conclusions than to facts; the English, and after them the French, being essentially inductive, and considering facts as of primary, conclusions of secondary, importance. Of the several English and French systems, however, this is most particularly the case with that of Herbert Spencer. His idea of evolution was gradually worked out through diligent study and widespread comparison of the facts discovered by science, beginning with its application to the laws of society, and gradually extending, as his studies widened, till it embraced the whole universe. This gradual growth, through the study of scientific facts, is essentially different from the deductive method of reasoning out a universal principle to begin with and then seeking support for it in facts. In the explication of his system, however, Spencer has been forced to adopt the latter method, first applying his theory to the basic conditions and relations of the universe, and then seeking their support in recorded facts. The latter labor constitutes the bulk of his work, which seems to

many overloaded with illustrative particulars, every step of the gradually unfolding argument being supported by an extensive array of quoted illustrations, and the whole work founded on a broad basis of the phenomena ascertained and recorded by modern science.

That any speculative philosophical theory can be indubitably established in this or any other manner cannot be affirmed. There may be no chance for two opinions respecting the characters of a mineral body, but the primary cause of gravitation, of animal development, etc., will always be open to a diversity of opinion, and dozens of theories in regard to the same phenomenon may be honestly entertained and susceptible of some degree of corroborative evidence. Yet the fact remains that the theory which accords with the greatest number of observed phenomena, which offers the most satisfactory explanation of nature's mysteries, and which meets with the fewest discordant phenomena, has the soundest standing as a law of the universe. Spencer has earnestly labored to sustain his theory by illustrations drawn from every field of science, and marshalling accordances into a cumulative array of evidences; though not until all facts are known, and all shown to be in strict accordance with a proposed law of nature, can an irrefutable system of philosophy be established.

As a logician and a thinker of broad grasp and deep powers of analysis and synthesis, Herbert Spencer has had few equals in the history of mankind. He is generally conceded to have unusual mastery of method, breadth of view, and capacity of organizing ideas, and none of his positions are easy of overthrow, however strong in fact and argument be his opponents.

Spencer, as has already been stated, is in imperfect health. His health was so broken when he began his great work that few of his friends believed that he would be able to go on with it, and of recent years he has been virtually obliged to abandon it, though he may yet live to complete it. He is a bachelor, living in a quiet boarding-house in the West End of London, and so careful and systematic in all his habits, literary and otherwise, that he has been enabled to do far more work than would otherwise have been possible to him. He visited America in 1882 and delivered some lectures, though soon obliged to give up all exertion in consequence of ill-health. In London he is a regular frequenter of the Athenæum Club, and makes billiards, concerts, and theatrical entertainments his principal amusements, alternated with long country-rambles, of which he is very fond. He has persistently refused to join scientific societies or accept university honors, or to yield to anything which might distract him from the chosen work to which he has devoted his life and strength. (c. m.)

SPIDER, an arthropod animal of the family *Araneida*, order *Arachnida*, this order embracing also the mites and scorpions. See Vol. II. p. 271 (p. 237 Am. Rep.). The *Arachnida* seem intermediate between the Crustaceans and Insects, differing from the latter in the close union of the head and thorax, the possession of simple eyes only, and the absence of antennæ and wings. There is no transformation, the young being born with the form and instincts of the adult. Maturity is reached after six moultings of the skin. The spiders possess four pairs of legs, an unsegmented and more or less spherical abdomen, and respire by means of both lungs and tracheæ. They are all carnivorous, and are provided with mandibles adapted to aid in taking their prey, the mandible ending in a powerful hook and being supplied with a poison-duct. The ocelli, or simple eyes, number 8, 6, or 2, in different species.

A peculiar and highly interesting characteristic of the spiders is their power of making silk, and the varied uses to which this substance is applied. Unlike the product of the silk-making insects, which is exuded from the under-lip, that of the spider comes from jointed spinnerets situated behind the anus, most spiders possessing 3 pairs of these appendages. They are conical papillae, surrounded by stiff bristles and hairs, and dotted at the apex with horny tubes varying from 100 to 1000 in number. The silk is secreted as a viscid liquid, which dries and hardens immediately on contact with the air. The silken filaments are very strong and fine, one coming from each tube of the spinnerets, while each line of the spider-web is composed of hundreds or thousands of smaller ones. According to Leuwenhoek it would take 4,000,000 of the fine filaments to make the size of a human hair. The supply of silk seems sufficient to make 6 or 7 webs during the season.

The sexes of spiders are separate, the males and females living apart. The females are oftenest seen, and are the larger, often considerably so, while their carnivorous instinct leads them frequently to attack and devour the males, even in the reproductive season. Spiders ordinarily obtain nutriment by sucking the juices of their insect prey, but sometimes swallow the flesh. They can support long fasts, and spend the winter in a torpid state. They are very cleanly in habit, and spend much time in clearing their body and limbs of dust and dirt. They have much ingenuity and perseverance, and display considerable intelligence in adapting themselves to circumstances and in changing the form of the web to suit the locality.

Nine-tenths of all spiders are included in the following families, as named and described by Emerton. The *Mygalidae* embrace the largest tropical species. They usually have very hairy and dark bodies, with only two pairs of spinnerets, one pair being very long, and turned up behind the abdomen. There are four air-sacs under the front of the abdomen, instead of two as in other spiders. The mandibles are very large, and work up and down instead of sideways. Most members of the family belong to the tropics, but there are some species in the southwestern United States. Some of the *Mygales* are very strong, *M. aricularia*, the bird-eating spider, being about 3 inches long, while its legs spread over 8 or 10 inches. It leaps upon and destroys humming-birds and other small birds.

The *Dysderidae* form a small family, of which there are few North American species. They are usually found under stones, the legs being drawn up close to the body. They have 6 eyes, and 4 breathing-holes, one pair of which leads to branched tubes instead of to sacs. The *Drassidae* are a large family whose members vary greatly in shape, color, and habits. They, like the above, make no webs, but usually live under stones, or in silken tubes on plants. They have small eyes arranged in two rows on the front of the head, and long spinnerets. The *Agelenidae* are a tribe of long-legged web-building spiders, of a brown color, and with one pair of spinnerets longer than the others. They build flat webs with a funnel shaped tube on one side, which forms the den in which the spider lies in wait for its prey. The *Ciniflonidae* are similar to the above, but differ in the possession of a peculiar spinning organ. This, called the cribellum, lies in front of the spinnerets, and has much finer tubes. The threads from it are drawn out and tangled, and are attached to the plain threads of the web, serving to make it more adhesive.

The *Lycosidae*, or running-spiders, form a numerous and interesting family. They live in open places, build no webs, and are very active in their movements, they having long legs, of which the

rear pair is the longest. The head is held high, giving an aspect of vigilance to the animal. The name of the family refers to their wolf-like habit of running down their prey. The *Atidae*, or jumping spiders, have usually a short body and square head, with a peculiar arrangement of the eyes, there being two large ones in the middle which give them a look of special animation. Their legs are short, it being their habit to leap on their prey. The *Thomisidae*, or crab-spiders, have bodies usually flat and widest in the rear, and somewhat resemble the crab in appearance. The front two pairs of legs are longer than the rear ones, and are bent in such a manner that the spider can readily move in a narrow crack. Some walk sideways, like the crabs. They build no webs.

The *Theridiidae* form the largest family of the spiders. They are generally of small size, with large rounded abdomens and slender legs. They build large webs, whose shapes differ for different species, and rest, head downward, under these webs, holding on by their feet. The most interesting family of web-builders are the *Eperidae*, the makers of the orb-like, geometrical webs which form attractive objects of spider-architecture. The species of this family are large in size, with short, round abdomens, flat heads, and eyes widely separated. The webs are made in lines radiating from a centre, and crossed by adhesive lines wound in a spiral or in concentric circles. Like the last-named family, the *Eperidae* hang head downward in the web, or in other cases live in a hole near by, keeping in constant communication with the web by the aid of a connecting line.

The ordinary belief that spiders are aggressive and poisonous is based rather on prejudice than fact. If not disturbed, they will not bite, though all spiders will bite when cornered. There are few satisfactory instances on record of their biting man, and stories of injury from spider-bites are mostly erroneous. The great majority of spiders are undoubtedly harmless to man, the tarantula, and perhaps one or two other species, being the only ones that need be avoided. Fear and prejudice, rather than fact, have given the spider its bad reputation.

It is by their spinning habits that the spiders are specially distinguished from other animals, the silken line, which is principally employed by insects in making a cocoon, or a nest for their young, being applied by the spider to a considerable variety of purposes. The spinning instinct is so strong that it is manifested by the young as soon as they have left the egg, those of certain species dwelling together in a common web till they are strong enough to build for themselves. Spiders in confinement begin to spin at once, and do not seem comfortable till they can go everywhere within their bounds on the web. As they walk, they draw out a thread behind them, while the young of many species, and the adults of some small species, use the silken thread as a means of flight, emitting sufficient to support them in the air by its buoyancy. It is believed that when they wish to descend they draw in a portion of this flying thread.

The leaping spiders make another use of the thread. When springing from a vertical wall on passing insects, as they frequently do, they always remain attached to the wall by a thread, and are thus drawn back and saved from falling. The water-spider makes a small silken tent on plants beneath the surface. This opens downward, and is filled with air which its occupant carries down, a bubble at a time. Thus domiciled, it runs about on the water-plants, and catches the minute insects that live upon them. Its hairs keep the water from its skin. Some species that live on land-plants make flat tubes of silk, in which they lie in wait. Others

build tents near their webs as lurking places. The species which live under stones, or in other places of concealment, all line their residences with silk. The large and well-known webs are built by comparatively few species. Of these there are a great variety, from the regular orb-web to that of irregular threads with a tubular den, which is common in grassy fields, and to the dome-shaped web, whose shape is retained by threads which run in various directions. One species builds a double web, under the upper of which it lives. The purpose of the lower is not known. The orb-weavers are usually bright-colored, and hang in the web with no attempt at concealment, but some species cover a place in the web with rubbish, under which they lie hidden.

Among the most interesting of the spiders are those known as trap-door spiders. The habit of building underground can be traced through a considerable variety of stages. The running spiders, when ready to lay their eggs, seek or make a hole in the ground, which they line with silk for a nest. Others dwell habitually in such silk-lined excavations, and build round the mouth rings of sticks and stones held together by web. In the species known as turret-spiders the circular excavation is about an inch in diameter and two inches deep, above which is built an irregular pentagon of bits of grass, straw, weeds, etc., crossing at the corners and bound with silk, rising to a height of 2 or 2½ inches. The inner surface is silk-lined, and the inmate crouches at the summit of his tower, peering out for prey. On the sea-shore turrets of tiny pebbles are made, and the sand of the tunnel is held firm by its silken lining. The trap-door spider constructs a similar underground tunnel, the summit of which is closed by a hinged lid, whose surface is covered with moss and other materials to make it resemble the neighboring ground. Just inside this door is the inmate's lurking place, where it clasps the door and holds it down so firmly that it cannot be opened without tearing. The foraging period of this spider is at night, at which time the door is thrown open and it ventures to some distance from its fortress in search of prey. Some of the trap-door species have a second tube, opening into the first, the entrance being closed by a valve-like trap not distinguishable when shut from the remainder of the tube. In still other species this second tube ascends to the surface, and affords an avenue of escape in case enemies should break through the two trap-doors. Insect ingenuity could scarcely go farther.

Another common use of the silk thread is in the making of cocoons for the young. These are small, round bags in which the eggs are laid. They are lined with the softest silk within, and often woven so closely as to be very hard and firm without. The spider pays great attention to its cocoon, which in some species is held by loose threads in the web, in others suspended by a stem. Some large species make a pear-shaped cocoon, which is attached to grass or bushes. Others build a hemispherical one against a flat surface. The running spiders carry the cocoon with them, attached to their spinnerets, and the young, when hatched, are carried for some time on the back of the mother.

Attempts have been made to use the silk of the spider as a material for fabrics, but with little success. The most recent experiments are those made by Prof. Wilder with a large southern species. He believes that an ounce of thread can be got from each spider during the season, this thread being from .007 to .004 inch thick, and much smoother and brighter in color than that of the silk-worm. Its fineness is such that several threads need to be twisted to obtain a size suitable for use. The difficulty in obtaining the silk, the labor in providing the spiders with food, and other impediments, make

the industry too expensive to promise satisfactory competition with insect silk.

Comparatively little is known about the senses of spiders. The general impression that they hear well, and even enjoy music, is not based on fully established facts. They are very sensitive to vibrations, and this probably has much to do with their apparent sense of hearing. The possession of a stridulating organ by some species, however, is an argument in favor of their hearing. They seem to be short of sight and with little power of appreciating form, their simple eyes being very imperfect organs of vision.

Spiders have many enemies, which attack both the eggs and the mature animals. Parasitic insect eggs are laid in the cocoons, and the larvæ, hatching first, prey on the young spiders. The mature spiders are eaten by savages in many parts of the world, and supply food to birds, reptiles, and insects. They are affected and frequently destroyed by parasitic mites, and some species are destroyed in considerable numbers by wasps, which paralyze them by a sting, and then store them in their egg-cells as food for their young when hatched. The spider, on the other hand, is very wary and alert in escaping his foes. Many of them have special lurking places and only venture out to take their prey, others conceal themselves in the web, some have the habit of shaking the web when in danger so violently that they cannot be seen, and many others when attacked at once fall from the web to the ground, and thus seek to escape peril. (C. M.)

SPOFFORD, AINSWORTH RAND, Librarian of Congress, was born at Gilmanton, N. H., Sept. 12, 1825. Failing health having prevented him from entering college, he removed to Cincinnati, and established himself as a bookseller and publisher. In 1859 he was engaged as associate editor by the *Cincinnati Daily Commercial*, and two years later he entered the Congressional Library, becoming librarian in 1864. Under his administration the national library has grown from 70,000 to upward of 600,000 volumes. The office of librarian has become an important one through the change in the copyright law effected in 1870. By this, all American copyrights are issued from his office, and copies of all copyright publications must be deposited in the library. Mr. Spofford has written much for the periodical press, and has published catalogues of the Library of Congress; *The American Almanac and Treasury of Facts* (annually since 1878); *Library of Choice Literature* (10 vols., 1881-88); *Library of Wit and Humor* (5 vols., 1884); and *Manual of Parliamentary Rules* (1884). In 1881 he received the degree of LL. D. from Amherst College. As a librarian he is known widely for his thorough knowledge of books.

(P. L. W.)

SPOILIATIONS, FRENCH. This term in American history, denotes the losses sustained by the owners of American ships confiscated by the French government during the war between France and England between the years 1778 and 1800. Under the Milan decrees of Napoleon, made to counteract the British Orders in Council, between 600 and 700 American ships and their cargoes were seized and sold. Jefferson, as U. S. secretary of state, in 1793 called on all merchants who had suffered or might thereafter suffer injuries, "contrary to the laws of nations and existing treaties," to forward the evidence of their claims to the department of state. In the negotiations for the settlement of these claims, which terminated in 1801, the French conceded that the claims were just, and repeatedly offered to pay the cash due. On the other hand, certain French citizens had claims against the United States, and the French nation itself had a valid claim for damages. The private French claims were slight and easily settled, but the claim of the

French nation was great. Under the treaty between the French and the struggling American nation, concluded in 1778, not only did the United States agree to fight for the French in America, but they agreed to allow the French ships of war to carry prizes into American ports and there condemn and sell them at all times. In return for these concessions the French king recognized the right of the new nation, and also gave such other valuable aid during the Revolutionary war as enabled the colonies to attain their independence. The obligation of the United States to stand by the terms of the treaty of 1778 was manifest. The damages done by English cruisers to French colonies, which American ships of war might have averted, constituted a valid claim against the nation. But more than all France valued her right under the treaty to bring her prizes into American ports. The American nation was extremely anxious to get rid of the obligations to permit her to do so. It was one of the triumphs of Jefferson's diplomacy which enabled this country to free itself from the entangling alliance made during the struggle for liberty. Taking the claims of American shipowners, which were then worth their face interest in gold, Jefferson offered them to the French on condition of a release in full for all obligations on our part, and the bargain was closed. The American government had taken private property and used it for the public good. Everyone acquiesced. Even the merchants who had lost their ships were pleased, because the American Constitution said, "Nor shall private property be taken for public use without just compensation." In 1802 the claims were first reported to the House of Representatives by Mr. Giles, in behalf of a select committee appointed for their investigation, and again, in 1807, by Mr. Marion of South Carolina. These two reports were a favorable statement of facts without recommendation, probably on account of the unfortunate condition of the finances at that time. In 1818 there was an adverse report by Mr. Roberts; in 1822, to the House, by Mr. Russell; in 1824, by Mr. Forsyth. In 1826, under the administration of John Quincy Adams, all of the evidence touching these claims, gathered from the documentary history and from the ample material accumulated in the archives of the department of state, was for the first time completely presented to Congress, and never since has there been an unfavorable report to either House. The objections to the payment of these claims found in the adverse reports referred to, in the "views of the minority" accompanying some of the favorable reports, in the veto messages of Polk and Pierce, in a speech of Silas Wright, made in the U. S. Senate in 1835, were as follows: 1. They are stale. 2. That the condition of the finances of the country will not admit of their payment. 3. That at the time they arose there was a state of war between the United States and France. 4. That they were embraced in the Louisiana convention. 5. That they were embraced in the convention of 1831 with France. 6. That Congress annulled the French treaties and thus effaced them. In 1886 Congress passed an enabling act allowing the claims to go before the Court of Claims. The claims were allowed, but Congress has so far failed to make an appropriation covering the several amounts. The legislatures of the 13 original States have all at various times passed resolutions directing their senators and asking their representatives to take favorable action in behalf of these claimants. It is estimated that, if interest be reckoned on the claims at 6 per cent., the aggregate would now be about \$80,000,000, as they will have increased to 6 times the original amount. A few of the undivided claims are as large as \$50,000, the average of them being about \$4300. Most of them have the necessary evidence on file. A very elaborate history of the claims was made by the House

committee on foreign affairs in January, 1884 (*Report No. 109*). (P. O. N.)

SPORTS, ATHLETIC. This article is confined to the popular American athletic sports.

BASE-BALL is the "national game" of the United States. Two sources are claimed for it: (1) An old English game called "rounders;" (2) a game familiar in parts of the United States, fifty and more years ago, known as "town ball." The weight of evidence seems to favor "town ball," though that may have been but a variation of "rounders." "Town ball" was systematized by the Olympic Club of Philadelphia, organized in 1833. The prosperity of this organization attracted enterprising ball-players and led to the formation of the first base-ball clubs, two or three of which came into existence in New York in 1845. The Knickerbocker Club was the chief promoter of this development. It adopted playing rules, Sept. 23, 1845, and started the game under auspicious circumstances. In May, 1857, the National Association of Base-ball Players, composed entirely of New York clubs, drafted and adopted a new code of playing rules. In 1860 the Excelsior Club of Brooklyn, by its exhibitions in tours through the cities of Western New York, Pennsylvania, and Maryland, gave an impetus to the spreading popularity of the game. What the Knickerbocker Club did in the earlier period of the history of the game in establishing base-ball on a permanent basis, the Excelsior Club followed up by their successful efforts to extend its popularity. These tours resulted in the increase of the National Association from twenty-five clubs in 1859 to eighty in 1861. Meanwhile amateur clubs outside of the Association were organizing all over the country, and the game was becoming familiar to every American boy. Not only did boys take to the game, but young and middle-aged men grew fond of it. The old National Association had not been flourishing ten years before professionalism began to find a foothold in the institution, and in 1869 and 1870 this element became a ruling power in the Association. A division followed, which resulted in the organization of two National Associations. The new bodies were the National Amateur Association, organized in 1871, wholly of amateur clubs; and the National Association of Professional Base-ball Players, organized the same year, wholly of professional clubs, a distinction which has ever since been preserved. From this time professional clubs multiplied rapidly, and soon the desire for closer organization sprang up, and professional Leagues, with schedules of games to be played for various championships, were formed by clubs representing different cities. These operations did not interfere with the progress of amateur clubs, which also multiplied, and had their sectional leagues, schedules of games, and attractive aims. The only check in the wonderful prosperity of the sport occurred at this time through sundry evils connected with pool-selling and the "cracked" element in the clubs. But these flagrant evils were opportunely and effectually destroyed by the stringent laws of the National League, established in 1876, and the American Association, a new body of professional clubs, established in 1881. The old National Association had passed away and these two new bodies had taken its place. For some time there was strife between them as to which should have chief authority in the base-ball world; each set up rules and laws of its own, and the bitter rivalry threatened the destruction of the honesty and popularity of the game. But the differences were amicably arbitrated in 1882, when the National League, American Association, and the Northwestern League entered into the "Tripartite Agreement," which in 1883 was developed into the "National Agreement." The parties to this

document, which has become the fundamental law of base-ball affairs, are now (1889) the National League, composed of clubs representing the cities of Philadelphia, New York, Boston, Chicago, Washington, Pittsburg, Detroit, and Indianapolis; and the American Association, consisting of clubs representing the cities of Philadelphia, Baltimore, Brooklyn, Cincinnati, Cleveland, Louisville, Kansas City, and St. Louis. Other prominent associations are the International Association, formed of clubs in Canada and New York State; the Central League, formed of clubs in New Jersey and adjacent States; and the Western Association, formed of clubs in States on the Mississippi; and the California Association. The laws of the game and rules governing its play, as framed under this agreement, are adopted by every base-ball organization in the United States. The rules may be changed every year to meet the exigencies of the times and to keep pace with the improving skill of the players.

The number of clubs, professional and amateur, in the United States, would run far into the thousands, every city containing from one to a hundred of them, in the supply of which over 12,000 balls are made daily. The professional clubs have well-kept grounds, fitted with every convenience to make the game attractive. The Philadelphia Club expended \$100,000 on its grounds in improvements alone, the seating capacity of the grand pavilion being over 10,000 people. Other

grounds seat as many as 15,000, and there occur times when 18,000 are in the grounds and thousands on the outside unable to gain entrance. Base-ball playing is now done on scientific principles, and adept players, with reputations, receive salaries of from \$2000 to \$4000 for a season of about six months. The players are held to the different clubs by approved contracts. As the success of a club depends largely upon the skill of its players, there is considerable competition every year in securing brilliant men; as high as \$20,000 is said to have been paid for the transfer of a first-class pitcher from one club to another. Considerable capital is invested in the sport, and the dividends are generally large.

Base-ball has not made much headway in other countries. Unsuccessful efforts were made to intro-

duce it in England, but there is an earnest endeavor to popularize it in Australia.

The following is a diagram of the ground, as it is required under the existing regulations.

The grounds are always diamond-shaped. At each corner is a square, called a "base." The bases, numbered first, second, and third, are marked by canvas bags, while home base is made of rubber. Home base is the starting-point in the game, and is directly in front of the catcher; first base is diagonally to his right. Lines drawn from the outer corner of the home base through the centre of the first and third bases, to the boundaries of the ground, are called "foul lines." The part of the field inside the diamond is called the infield; that outside of it, but inside the "foul lines," is called the "outfield."

In a game nine players are required on each side; these are a catcher, pitcher, first, second, and third basemen, short stop, left, centre, and right fielder. Each club has a captain, who is always one of the nine players. Each has a tenth man as a substitute when a regular player is recalled or disabled. The positions of these players are indicated in the diagram; their duties are prescribed by rules. As to their abilities, each must be a good fielder and a good batsman, and if he is also a good base runner so much the better. He must be a sure catcher and swift, accurate thrower. The most responsible position is that of pitcher. His skill and tact generally decide the game.

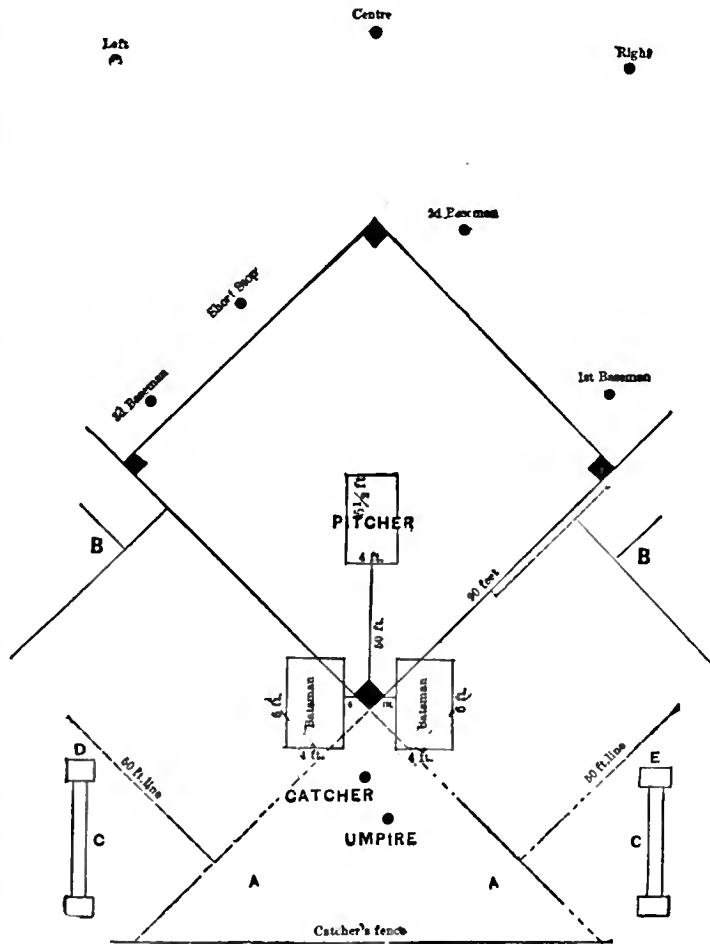

FIG. 1.—Base-ball ground.

A, A, Reserved for Umpire, Batsman, and Catcher; B, B, Reserved for Captain and Assistant; C, C, Players' Benches; D, E, Bat Racks.

Next to him is the catcher; and next, the short stop. The umpire is a judge regularly appointed to decide all points of dispute that may arise during the game. He also superintends the play, signifies when the game is to begin, passes judgment on all balls pitched by the pitcher, and decides whether the players are "out" or not. In short, he is master of the field from the commencement to the termination of the game, and must compel the players to observe the provisions of all the "playing rules." He generally stands behind the catcher, that he may see and judge the balls thrown by the pitcher and watch the players and plays.

The materials for play are a ball and a bat, no more than one ball and no more than one bat being used at a time. But if a ball be lost or ripped, or a

bat be broken, a new one can take its place. Each batsman generally has a bat to suit his own taste and strength. The ball is spherical and elastic enough to spring when hard hit, but not so elastic as pure rubber. It must weigh between 5 and 5½ ounces avoirdupois, and measure between 9 and 9½ inches in circumference. The bat is a round, tapering club, though a portion of the surface may be flat on one side; it must not exceed 2½ inches in diameter in the thickest part and must not exceed 42 inches in length. The bases are canvas bags stuffed with saw-dust or excelsior; the home base being made of rubber, that it may have a flat surface and avoid injury to runners. The catcher uses a wire mask, inflated rubber chest-protector, and padded gloves; the pitcher wears a brass toe-plate; the first baseman also wears padded gloves. The players are uniformed, each club wearing regulation hats, suits, belts, and shoes.

A Match-game—With the above facts in mind, a still clearer knowledge of base-ball can be obtained by going through a game. Therefore let us play one or two "innings," and introduce the "points" as they occur. We will suppose the game to be between the Philadelphia and Chicago Clubs. The two captains having decided by toss which shall go out in the field and which shall stay in to do the batting, the umpire "calls" the game to begin. The Philadelphia players have the "outs" and take their places in the field; the Chicago Club have the "ins." When three of their players have been "put out," their whole side will be "out," and the Philadelphia club will take its turn at the bat. The game usually consists of nine of these double innings. All being in readiness, the umpire calls "game," tosses a new ball to the pitcher, and prepares to judge the throwing. The first batsman of the Chicago Club steps into the quadrangle, beside home base, and gets ready to hit the ball. The Philadelphians wish now to prevent the batsman from reaching first base. The pitcher wants to throw the ball in such a manner as to deceive the batsman and make him "strike" out. The batsman's aim is to avoid this by hitting the ball so that he may run and reach first base before the ball can be thrown there. The pitcher takes careful aim and sends the ball whirling toward the catcher. Every ball must pass over the home base between the knees and shoulders of the batsman. Every time it fails to do this, the umpire calls "ball," and every time the ball passes as required, he calls "strike," whether the batsman aims at it or not. Four of these "balls" entitle the batsman to run to first base, while three of these "strikes" put the batsman "out;" *i. e.*, force him to give place to the next batsman, so that, generally, the pitcher has never to pitch more than seven balls to decide whether a batsman goes out or not. The game being now in motion, let us suppose that the batsman has tried to hit the ball with his bat, but has failed. This failure may be owing to the speed of the ball or the curve it takes, and the batsman's misjudgment. Every such attempt and failure to touch the ball is called also a "strike," and three of these will put him out. In other words, a batsman can be put out on "strikes" in either of two ways: on strikes called by the umpire or on strikes made by himself. At length he knocks the ball into the field along the ground in such a way that the fielders fail to stop it before he reaches first base. This is called a "base hit." He has now become a "base runner," and his object is to reach second base, then third base, and then "home." He can do this in either of two ways: run swiftly to second base while the ball is passing from pitcher to catcher, or wait till the next batsman hits the ball, and sends him to second base. If he does the former he is said to have "stolen" second base; if the latter, he has been

"forced" or helped to second base. Batsman No. 2 knocks the ball "fair" enough, because it goes in front of the "foul lines," but it flies up into the air, and is caught in the air by centre fielder, and held. This is called a "fly" ball, and batsman No. 2 is said to be "out on a fly." No. 1 is still on first base, not being allowed to run on a caught "fly," and No. 3 steps up to bat. He knocks the ball and it rolls slowly toward first baseman, who picks it up and touches his foot to the bag before No. 3 can reach there, but not quick enough to prevent No. 1 from running to second base. This puts No. 3 out. There are now two men out, Nos. 2 and 3, and only one more needs to be put out to prevent No. 1 from reaching "home" and scoring a run. No. 4 hits the ball so hard as to send it flying over the head of the left fielder, and before it can be stopped and thrown in toward the pitcher No. 1 has touched third base and the home base, and scored a run; while No. 4 has reached second base, having made a "two-base hit," because he reached second base before the ball did. No. 5 comes to bat, and while waiting, the pitcher, trying to catch No. 4 napping, makes a feint to pitch the ball but does not do so. The umpire detects him, and calls it a "balk," which permits No. 5 to take first base, just as if he had hit the ball, this being the penalty for "balking." There are now two men on bases and No. 6 comes to bat, but while he is waiting to aim at the ball No. 4 tries to "steal" third base; but the pitcher, ever-watchful, detects him, hurls the ball to third baseman, who catches it and touches No. 4 before he can reach the base. This puts him out, and (since three have now been "put out") closes the Philadelphians' part of the "inning." The Chicagos now go into the field, and the Philadelphians come in to bat. Batsman No. 1 steps up to bat. He hits the ball fiercely to short stop, who picks it up and throws it swiftly toward first baseman, but it is too high and goes over his head. Before it can be recovered No. 1 has reached the base. He has gained so much on an "error"—made by the short stop. No. 2 waits in vain for a "good" ball. The pitcher is excited by the short stop's mistake, and throws the ball so wildly that the umpire calls "ball" after "ball" until four are counted, and No. 2 goes to first base. This forces No. 1 to second base. Nobody is out yet, two men are on bases, and No. 3 is ready to bat. The pitcher is still unstrung, and pitches so wildly that the ball hits No. 3 in the side. The umpire tells No. 3 to take his base, this being the penalty for hitting a batsman with the ball. No. 3 forces No. 2 to second base, and No. 2 forces No. 1 to third base. The bases are now said to be "full" and no one out. The chances for "runs" are excellent. No. 4 takes up the bat and knocks the ball to short stop. Every man is forced to run. It is a critical stage. Short stop picks up the ball, touches No. 2 like a flash, and then throws the ball to the catcher, who receives it before No. 1 can reach home. Two men are thus put "out"—No. 2 and No. 1—and a "double play" is made. There are now two out, and two men on base: No. 3 on second and No. 4 on first base. The Philadelphians are anxious for a "run," and No. 5 hits the ball so hard that it goes far beyond centre fielder, and before it can be recovered No. 5 has made the whole circuit and reached "home," making a "home run" and sending in Nos. 3 and 4, each with "runs" to his credit. No. 6 hits the ball, but it goes up into the air outside of the "foul lines." The catcher is nimble and catches it before it touches the ground, and No. 6 is said to be out on a "foul fly." Three men are out, and the other part of the "inning" is finished. Two such parts make up an "inning" and nine "innings" constitute a game. The "score" for this first inning is 3 runs to 1 in favor of the Philadelphians; and the Chicagos come

in to bat again. And so the game goes on, alternately, until nine innings are finished, the club having the most runs winning. If the score be even or "tie," more innings have to be played until either side exceeds the other. Games usually begin at 4 p. m. and last two hours. If darkness gathers before the game is done, the umpire can call the game to stop, and the club which is then ahead wins.

The season for base-ball is from April 15 to October 15, the summer months being the most favorable time.

(N. Y. N. Y.)

Dr. Leuf's *Hygiene for Base Ball Players* (A. J. Reach & Co., Phila.) gives the following explanation and illustrations of "curve-pitching," as now practised. Its principles have been thoroughly investigated, both as regards the varieties of curve and the muscular effort required to effect them. The object of

Always aim over the plate and the ball will be seen to curve in, the amount of the curve depending upon the rapidity of the twist imparted to the ball by the fingers. The greater the full-length swing of the arm, the greater is the speed and more sudden the curve of the ball. Sudden sharp curves are called "shoots," and the in-shoot is the most marked because it is easiest to give it the most rapid twist and the swiftest momentum. The twist of the in-curve ball is forward and from left to right, and any kind of delivery that will give it this gyration with sufficient rapidity will cause the ball to curve in.

The out-curve, so called because it turns out from the batsman, is generally produced by rolling the ball off the thumb side of the index-finger with the palm turned up and the little-finger edge of the hand facing the opposite shoulder (Fig. 3). As in

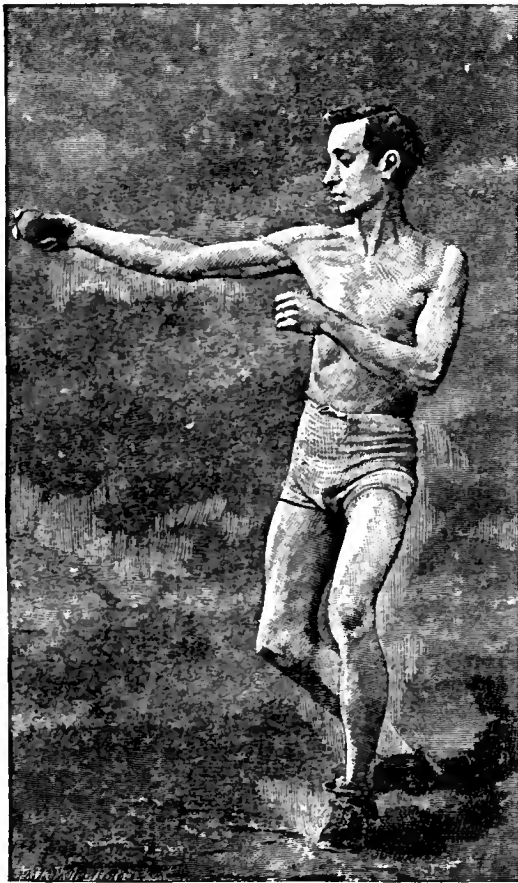

FIG. 2.—In-curve.



FIG. 3.—Out-curve.

the curve pitching is to outwit the batsman while the pitcher gains a point for the benefit of his own side. There are four curves used: The in-curve, the out-curve, the down-curve or drop-ball, and the up-curve or rising ball, which are here explained.

The in-curve, so called because it turns in toward the batsman, is produced by rolling the ball off the tips of the fingers with the palm of the hand facing directly forward (Fig. 2). The ball must be grasped with sufficient firmness to prevent its premature slipping out of the hand. The arm is drawn back, and with a full-length swing brought forward, usually on a level with the shoulder. When about opposite the shoulder, the elbow is bent in toward and across the chest, at the same time sharply bending the wrist and making a sudden jerky finger pressure upon the ball to give it the necessary twist.

every kind of pitching, the arm is first drawn well back so as to give it plenty of swing in coming forward in delivery. The elbow is slightly bent and, as the arm comes forward and just before letting go the ball, there is a simultaneous side-bending of the wrist on the little-finger side toward the opposite shoulder, and a slightly jerky movement of the elbow backward and away from the body. These complex movements send the ball out of the hand with a sudden jerk from the thumb side of the index-finger, with the hand upturned, and give the ball the requisite twist to make a good curve and also insure adequate speed. The twist of the out-curve ball is forward and from right to left.

The down-curve or drop-ball, so called because it descends sooner than if it had been thrown in the ordinary manner, is rolled off the thumb side of the

index-finger as in the out-curve, with the difference that the palm, which is now brought over the shoulder, is turned directly upward, with the little-finger side facing the breast (Fig. 4). The arm is first

thumb side of the index under the hand. This is a necessary movement—to impart the proper twist, and at first is found difficult to execute. The ball leaves the hand with a remarkably sudden jerk, and on that

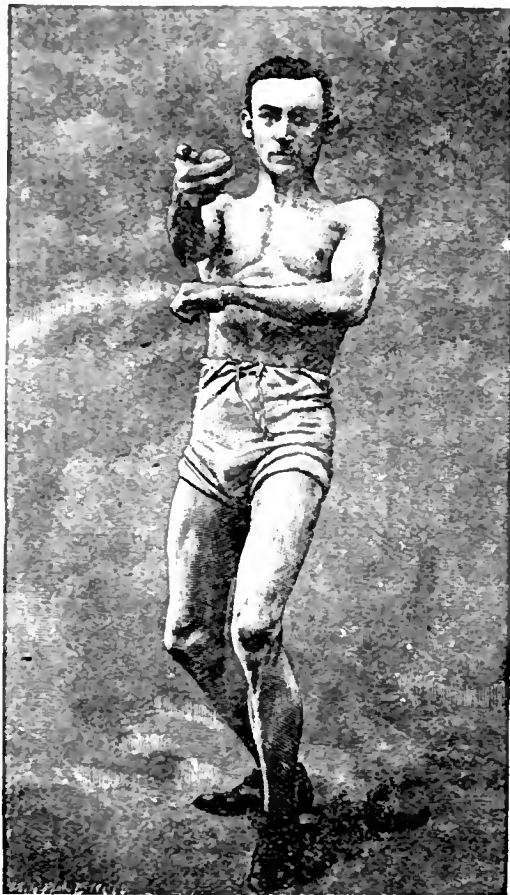

FIG. 4.—Down-curve.



FIG. 5.—Up-curve.

swung back behind the head, from which position it is brought forward on about a level with the top of the head. In this the mode of drop-ball delivery the elbow is of course necessarily bent. Immediately after passing over the shoulder, the arm is as suddenly and as forcibly as possible pulled down, the palm is turned up, and the hand bent in toward the chest on the little-finger side, and the ball permitted to roll off the thumb side of the index-finger. The sudden, shoulder motion must be mainly depended upon for speed, while the wrist motion determines the rapidity of the twist, and hence the extent and suddenness of the curve.

The up-curve, or rising ball, so called because it has a peculiar ascending motion, and falls to the ground farther away than if it had been thrown in the ordinary manner, is the most difficult to master, but always the easiest curve to make when once learned (Fig. 5). Here the ball is also rolled off the thumb side of the index-finger, but in a manner that at first is extremely awkward, and, in fact, seems almost impossible. The body is bent forward, and the arm drawn back and well up so as to get a good start for the forward swing. As it is brought down at full length it comes forward at about the level of the knee, and just here the palm is turned as far upward and backward as it can be twisted, with the little-finger side directed upward toward the face of the pitcher and also slightly bent back, when the ball is permitted to roll off the

account gets great speed and a very good twist and resulting curve. (A. H. P. L.)

FOOT-BALL is not so popular in the United States as base-ball, and has no professional clubs. Its principal favor is with students in academies and colleges. There are amateur associations, and several intercollegiate leagues, and by these the game has been made somewhat scientific. The principal football organization is the American Intercollegiate Association, comprised of "elevens" from Harvard, Yale, Princeton, Wesleyan, and the University of Pennsylvania. This body yearly arranges a schedule of games which are played for the championship of the United States. The contests between these "elevens" create wide interest and are played before crowds of 5000 to 15,000 people, who pay liberally for the privilege. Yale has won the championship pennant in 1876, 1881, 1882, 1883, and 1888. Foot-ball, as played in the United States, resembles the Rugby game more than the Association or Harrow game of England. Under the rules of the American Intercollegiate Association the game is as follows:

The field is rectangular, 330 by 160 feet. The rectangle is outlined by broad whitewash lines, as in tennis. At each end are the "goal lines." Inside of these and the side lines the game must be played. Parallel with the goal lines and running across the field at a distance of 75 feet from each goal are lines called the "25-yard-line limit of kick-out." In the

middle of each goal line stands the goal—two upright posts, exceeding 20 feet high, and placed 18½ feet apart, with a cross-bar 10 feet from the ground. Every ball, to count in the score, must cross the goal line. The value of each point in scoring is: Goal from "touch down," 6; goal from "field kick," 5; "touch down" failing kick, 4; "safety," by opponents, 2.

The ball is of oval shape, inflatable, made of India rubber, and cased in leather. A foot-ball team consists of seven "rushers," known as centre rusher, his right and left guards, and two end rushers; one quarter-back, two half-backs, and a full-back. The captain is one of the eleven, and directs the movements of his team. The main office of the rushers is to keep their opponents away from the ball. The centre rusher puts the ball in play, and should be a man of weight and muscle. The quarter-back looks after the disposition of the ball. The half-backs must be wiry, swift, and deep-chested. The full-back is the emergency man, and must be a good kick and a sure "tackler." There is an umpire and a referee: the umpire is judge for the players, and his decisions are final regarding "fouls," i.e., violations of rules and unfair tactics; the referee is judge for the ball, and his decision is final on all points not covered by the umpire. The time of game is usually 1½ hour, each side playing 45 minutes from each goal, with 10 minutes intermission between the two halves. The game is decided by the score of even halves.

Foot-ball can be best illustrated by going through and explaining the steps in an actual game. Let us describe a contest between the Yale and Harvard "elevens."

The two captains toss up for choice of goal or "kick off." (A "kick off" is a "place kick" from the centre of the field of play and cannot secure a goal, a "place kick" being made by kicking the ball after it has been placed on the ground.) Yale wins the toss, and the rival teams walk into the centre of the field. Here there are three lines, running parallel with the goal lines, five yards apart. The centre line is for the ball; the other two are for the rival "rush lines," made up of the seven "rushers." The rushers face each other, spreading out, with their faces toward their opponents' goal. Behind the centre rusher stands the quarter-back. Five yards behind him, diagonally to his right and left, stand the two half-backs, and ten or more yards behind them, centrally, stands the full-back. Between the two lines of rushers, five yards directly in front of the centre rusher, is placed the ball.

The Game.—All in readiness, the referee signals to begin. The ball can be put in play only by the centre rusher in one of two ways, as directed by the captain: viz., either kick it strongly toward Harvard's goal, a proper "kick off;" or lift it with his toe, catch it as it rises, and pass it behind him to his nearest man, a feint to "kick off." The latter is the commonest and safest mode of opening. Yale's captain having signalled the centre rusher to feint, he passes the ball quickly to a chosen man, generally a half-back. Yale's aim is to get the ball over Harvard's goal line, while Harvard's object is to prevent such success. Accordingly the Yale man, with the ball, darts for the coveted goal, while his colleagues strive to block and keep away from him their opponents. He has hardly gone ten yards before a burly Harvard man, bursting past every obstacle, seizes him round the waist and drags him to the ground. This is called a "tackle," and the man with the ball cries "down," and is released. The scattered teams reform, or "line up," on the spot, facing each other as before. As the Yale man clung to the ball, it goes again to his centre rusher. It can now be put in play either by a "kick off," by the centre rusher, or

by being "snapped back," when it must touch at least three persons. The first way is usually impracticable, so the centre rusher, at a signal from the quarter-back, snaps the ball backward with his foot toward the latter, who seizes it instantly and throws it to a signalled half-back, who proceeds to dart between the enemy or out around them, while after him rush the Harvards, harassed and impeded by the Yale rushers. The man with the ball is surrounded, but before he can be "held" he passes the ball back to one of his men, who continues the dash, and immediately becomes the object of attack. In attempting to run round the enemy, he is forced beyond the limit line at the side. He must now stop and come back to the point where he passed "outside." The men "line up" as before, and now the ball must be put in play by the end rusher nearest the side line. He can do it in either of the ways allowed the centre rusher, but he chooses to snap it back, and the quarter-back passes it to the half-back, who tries to force his way through the battling crowd. (The moment a "snap back" is made, the Harvard rushers spring in and strive to break through the Yale "rush line" and capture the ball. Here the heaviest fighting occurs. The rules forbid the use of fists in fighting through the crowd, under penalty of disqualification. But the man with the ball can use his elbows, shoulders, or open palm to throw off assailants. The ball is always carried tightly under the arm opposite the enemy.) The half-back makes an attempt to dive between the men, but is caught suddenly and thrown and "held," i.e., intercepted—he is said to be "down." If in four of these "downs" the side with the ball does not gain at least five yards, the ball passes over to the other side. The possession of the ball is a decided advantage. The Yales have now three "downs," and must gain two yards to keep the ball. The goal with the chance of scoring is still 50 feet away. They "line up" quickly and the ball is snapped back. The quarter-back throws it to the half-back, who dashes gallantly through the crowd, gains clear ground, and makes for the goal, with the enemy at his heels. But he is too fleet for them, and, dodging the full-back, he crosses the goal line and touches the ball to the ground between the goal posts. This is called a "touch down," and counts 4 points. When a "touch down" is made the ball is brought back into the field, to a point on the "25-yard-line limit of kick-out" opposite the place where it touched the ground, and is held very close to the ground (but never touching it). The man thus holding the ball lies on his side and tries to drop it just in time for some one of his team (the most accurate kicker) to kick it through Harvard's goal posts and over the cross-bar. If he succeeds it is called a "goal from touch down," and counts 6 points. If he fail, Yale is credited with merely a "touch down." He succeeds, and so increases the score by 6 points. The ball is now placed in the centre of the field, as at first, and the elevens resume the positions they occupied at the beginning of the game, with the difference that Harvard has the ball. The game opens with a proper "kick off," and both sides sweep after the ball. It falls near the Yale goal line, and before Yale's full-back can return it, i.e., kick or carry it back, the Harvards pounce on him and have it "down." If, during the rush that is about to take place, the ball be forced back across Yale's goal line, or so near to it as to run the risk of a "touch down," Yale is permitted the choice of a fight or a concession. If the latter, they carry the ball over their own goal line and themselves make a "touch down," which is called a "safety" and counts 2 for Harvard. This is always a bitter resource. But if they decide to fight, the ball is put in play regularly and thrown to the full-back, who kicks it

high over all heads toward the Harvard goal. If the ball chanches to go over the side bounds of the field both sides make a rush for it, and the side capturing it out of bounds bears it back just within the limits. If it strikes inside the field, the side catching it puts it in play. Harvard gets the ball, and they put it in motion, and their half-back breaks through all restraint and makes a "touch down." But as he did not get near enough the goal posts to make a "drop kick," his play is to "punt out" the ball (made by a player of the side which has made a "touch down" in the opponents' goal to another of his own side for a fair catch). His object is to punt so that the ball will be caught in front of the goal posts. Accordingly, Yale "line up" along their goal line; while Harvard, excepting the punter, "line up" 15 yards away, facing Yale. The punter takes his position among the Yale men, who must be 10 feet away from him on either side, and makes the "punt" by letting the ball fall from his hands and kicking it before it touches the ground. If a "fair catch" be made the ball is passed to a Harvard man, who holds it for a "drop kick" as before. But if the ball be missed, the moment it touches the ground it is in play again, and can be rushed by either side. The Harvard man misses the ball, intentionally or otherwise, but it is saved by one of his side, who grabs it, and the men "line up" again. (This "line up" takes place every time the ball is about to be put in play.) The centre rusher snaps it back and the quarter-back throws it to the full-back, who "drop kicks" it unerringly through the Yale goal posts, making a "goal from field kick," which counts 5. The referee now calls "Time," and the first half is played. An intermission of ten minutes takes place, the score standing: Harvard, 9; Yale, 6. And so the game continues until the time is ended. All time lost by accidents or allowable delays is added to the regulation time, that the full limit may be occupied. In games between such teams as Harvard, Princeton, and Yale more than 15 points are seldom made by either side, a few points often deciding the game. But between these and inferior teams the score mounts even into the hundreds, Harvard defeating Exeter in 1885 by a score of 158 points to 0, the greatest on record. (U. S. N.)

JUMPING. In this sport the records are confined, for the most part, to amateur athletic associations. Among amateurs a fair record for the running broad jump is 17 feet 9 inches; and for the running high jump about 5 feet. Only a few years ago a standing jump of 5 feet 7 inches was considered marvellous, and but few American athletes could attain even that. Now there are several men in almost every large city who are able to accomplish it. There are many ways of approaching the bar practised by good athletes, but those who lead in this sport run toward it directly at right angles. When the bar is reached the body should be crouched as low as possible, as only by that means are all the muscles of the body brought into play. The leverage of the back is also important in assisting the jumper, and by constant practice the cartilages may be brought to a high state of elasticity. The method practised is to approach the bar with three unequal long bounds and two short ones, after which the crouching position is assumed. When making the final spring the jumper twists the right foot violently outward, after which both arms and legs are jerked suddenly upward to give additional impetus to the jump. The knees are brought into contact with the chest, thereby causing the body to occupy the smallest possible space when crossing the bar. The sudden twisting of the right foot outward imparts a similar motion to the body, thereby causing it to turn half-way round from left to right. When the body is near the top of the bar the right arm is

jerked toward the shoulder, and a similar motion with the left should follow. At the instant the arms are jerked the legs should be shot out from their doubled-up position, thus carrying the body still farther upward. The highest record of this sort was made by E. Byrd Page, who cleared 6 feet 4 inches, in Philadelphia, Oct. 7, 1887.

ROWING is a pastime which has closely followed the practice in England; but it differs from it, more especially with regard to the stroke. The stroke usually adopted in England, known as the "book-stroke," makes the rower reach forward as far as he can, and requires him to pull it clear through until his body is well past a perpendicular. At first scarcely any of the American oarsmen adopted this stroke; and yet they differed from each other as much as they did from the English stroke. The champion scullers, the professionals, and amateurs appear to vary as much as they possibly can in their ideas of what a correct stroke should be. It is described by Edward Hanlan, of Canada, long the champion of the world, as follows: "Instead of spreading my knees apart, as most rowers do when reaching forward, I sit in a natural position with my legs and arms directly in line as they stretch out before me. In coming back the knees close somewhat, but not entirely, the elbows come close to my sides, and the hands lap over about 6 inches. This wide spreading of the knees and stretching forward to the last inch of reach puts those who adopt it into a cramped position when their oars catch the water, thereby wasting strength and purchase. Open-handed oars I never use. For my great point is to utilize my every ounce of strength, and open-handed oars fritter away a man's strength by spreading his arms too wide when he takes the water. Being convinced that more speed is got aft of the rowlock than forward of it, I pull an easy stroke until my body is straight in the boat, and then shove through steadily with all my strength, but so balancing the stroke as not to jerk the boat at the finish. I don't begin to slide until my oars have taken a good hold on the water, for I can only get all my weight on a stroke by having my legs and arms act simultaneously—that is to say, by bringing all my rowing muscles into play at the same time. Force is lost by a premature using of the slide. In turning, after getting just past the flag, I drop my left oar almost straight down into the water, with elbow close to side, put my whole weight on it, leaning slightly to the left, so that both ends of the boat are raised above the water and she can pivot on her bilge, and then pull her around with steady strokes of the right oar. Every inch tells in the long run, and it is by studying such little points as these that I obtained and keep my place as champion oarsman of the world." In the American colleges a variety of strokes was used until 1872, when the leading colleges began to adopt the English stroke. The results have shown that it has won more races than the hap-hazard strokes that have been adopted by the different crews from year to year. In 1883 the Yale College oarsmen adopted a very fast stroke, but they suffered defeat at the hands of the Harvards, who had adopted the long sweeping stroke of the English. The Harvards had adopted this stroke by degrees for ten years previously; and even the Yale men had won with the same stroke in 1876. The victory of the long stroke in 1883 was the more significant because the Yale men were giants in comparison with the Harvard men, and they kept up their stroke of 42 to 45 a minute to the very end without apparent fatigue. The inference was that the longer stroke was the best.

Among the professional rowers of America the Ward brothers, of Cornwall, N. Y., appear to have been the pioneers. Later, the championship of the

world was secured by Hanlan; and, in 1885, by William Beach, of Anstralia. The championship of America was won by O'Connor, of Toronto, in December, 1838. Among amateurs the leader for many years was Charles E. Courtney, of Union Springs, N. Y., who afterward became a professional and made the extraordinary time of 3 miles in 19 minutes and 27 seconds. In 1885 a great race was rowed at Albany between Courtney and Conley, on one side, and Hosmer and Gandaur, for the double-scutt championship of the world. The race was won by Courtney and Conley.

Rowing in the United States has been more rapidly developed through the races between the several universities and colleges than through any other source. In fact, the history of these races may be said to have marked nearly all of the history of its advancement. In 1852 Harvard and Yale rowed their first race of 2 miles on lake Winnipiseogee, in New Hampshire. Harvard was represented by the Oneida, an 8-oared boat, 38 feet long; and Yale, by the Halcyon, also an 8-oared barge. Yale won by 2 lengths, the time being about 10 minutes. In 1855 Harvard put forward an 8-oared and a 4-oared boat; and Yale, two 6-oared boats. The former won. In 1859 Harvard had a shell and a lapstreak, Yale a shell, and Brown a lapstreak. Harvard was the victor. In 1859 Yale beat by 2 seconds; and in 1860 Harvard beat by 12 seconds. Down to this point the races were so irregular, as to the classes of boats entered, that no fair test could be made. In 1858 a movement was made toward an intercollegiate regatta. Harvard, Yale, Brown, and Trinity responded; but nothing was done until 1860, with the result above noted. The civil war postponed further efforts until 1864, since which time the record of the university races is as follows—the course being 4 miles.

Year.	Winner.	Time.		Won by.
		Minutes.	Seconds.	
1864.	Yale.....	19.01	42½	
1865.	Yale.....	17.42½	46½	
1866.	Harvard.....	18.43	57	
1867.	Harvard.....	18.13	72½	
1868.	Harvard.....	17.48½	50	
1869.	Harvard.....	18.02	9	
1870.	Harvard.....	20.30	Foul.	
1871.	Agricultural (three colleges).....	16.46½	37	
1872.	Amherst (six colleges).....	16.33	24	
1873.	Yale (eleven colleges).....	16.50	10	
1874.	Columbia (nine colleges).....	16.42	8	
1875.	Cornell (thirteen colleges).....	16.53½	11	
1876.	Yale.....	22.02	20	
1876.	Cornell (six colleges).....	17.01½	4	
1877.	Harvard.....	21.36	7	
1878.	Harvard.....	26.44	45	
1879.	Harvard.....	22.15	93	
1880.	Yale.....	24.27	42	
1881.	Yale.....	22.13	6	
1882.	Harvard.....	20.47	3	
1883.	Harvard.....	20.40	73	
1884.	Yale.....	21.51	15	
1885.	Harvard.....	25.15½	74½	
1886.	Yale.....	20.41½	10	
1887.	Yale.....	22.56	14½	
1888.	Yale.....	20.10	74	

In 1883 Cornell beat Pennsylvania, Princeton, and Wesleyan on Lake George; and in 1884 Pennsylvania beat Princeton, Cornell, Columbia, and Bowdoin. For a time Harvard and Yale had everything their own way. In 1871 Harvard, Amherst, Brown, and Bowdoin organized the "Rowing Association of American Colleges," for the purpose of using the course at Springfield, Mass. In 1872 Harvard was defeated by Amherst, and Yale was the last to reach the goal. This result encouraged boating among the smaller colleges, so that in 1873 eleven crews entered. Disputes having arisen in regard to the line of finish, there was a disagreement upon the results between Harvard and Yale for several years which helped

other colleges to win the intercollegiate races. Harvard and Yale, however, met again in 1876, and the contest between the two leaders has been continued to the present day.

The original Oneida, of the Harvards, was a type of the club-boats down to 1855. It was a lapstreak, very heavy, with a straight stem and no sheer. The width was 34 feet in the widest part; and the oars were placed in pins fastened to the gunwale. The boats used by Yale in 1852 were of a similar pattern. In 1855 the Oneida received small outriggers of wood, which was the first appearance of such arrangements in America, although they had been used in the Oxford and Cambridge races after 1846. Soon after 1855 Harvard secured an 8 oar racing boat, a lapstreak 51 feet long, with outriggers. In 1857 Harvard built the first 6-oared shell ever constructed in America. It was 40 feet long, 26 inches wide, and carried iron outriggers. The boat weighed 150 pounds—a great gain over former boats—and the material was white pine. In 1859 the Yale men brought a new shell of Spanish cedar, 45 feet long, 24 inches wide, and weighing 150 pounds. Yale carried a coxswain; Harvard carried no coxswain or rudder. This, the first racing between shells in America, was won by Harvard. The two lapstreaks also entered for the race were left behind so far that the advent of the shells marked a new era. Then came the adoption, by Harvard, of a rudder steered by the bow oar by means of wires. In 1870 Yale introduced the sliding seat, which immediately called forth a long debate as to its merits; but it was soon accepted as a positive advance in the art of rowing. In 1885 paper boats began to be used; and they are now almost universally employed.

RUNNING. Foot-races of 100, 200, and 440 yards are often won by a few inches, and the value of an inch or two in a runner's stride is of great importance. Relatively long limbs, with a short body, full chest, and small bones will win the day as against long bodies and long limbs. The small girth of the legs of runners has often been noticed. From the girth of the muscle may be obtained a correct idea of its volume, and but little idea of its length or the extent of its contraction. Length of the muscle, and not thickness, is of advantage to short-distance runners. One of the champion runners of the world is but 5 feet 7 inches in height; but he has a length of lower leg which corresponds to a man 3 or 4 inches taller and a length of thigh belonging to a man almost as large. Running records have not been preserved as carefully as the records upon other athletic sports. It may, however, be stated that for a 100 yards run a fair record is 10 to 11 seconds; for a 440 yards run, 57 seconds; for a 220 yards dash, 25 seconds. The records for running a mile differ, so that but little significance can be attached to them. The half-mile was run by Cross, of England, in 1 minute 54½ seconds in New York in 1888; the 100 yards, by Westing, in 10 seconds; the 1¼ mile, by Coneff, in 6 minutes 3 seconds; the 250 yards, by Pelling, in 24½ seconds. Westing and Pelling broke the records.

SKATING, in the United States, follows at a considerable distance behind the practice of the art in Canada and in the northern countries of Europe. In fact, no Americans have yet been found who could compete successfully, either in speed or in grace, with natives of those countries. The championship of America was won in 1884 by a Norwegian, Axel Paulsen, who skated 10 miles in 39 minutes 7 seconds. Soon afterward he made 25 miles in 93 minutes 28 seconds. Both of these records were considerably in advance of the fastest time down to that date. The fastest authentic time on record in America was made by Tim Donohue, Jr., on the Hudson River, near Newburg, N. Y., in 1887. The mile was made in 2 minutes 12½ seconds.

Formerly the best skate used in America was known as the "Dutch rocker," but the wooden skate has passed away. About 1870 a skate imported from Canada, called the "Acme," proved superior to any manufactured in the United States. Now the "Club" skate appears to be the favorite. It is built upon a plate of iron or steel which fits closely to the sole of the boot; and the blade is made of the finest steel. It costs three or four times as much as the original Dutch rocker. The latter always had a groove running lengthwise of the blade; and this required continual sharpening so that the skate might take a better hold upon the ice. But with the Acme skate smooth bottoms were introduced, and grooved skates have not been manufactured since.

From about 1875 to 1880 many rinks were built in the United States for the purpose of roller-skating. This skating could be practised at all seasons of the year, but its free exercise was found to foster immorality. The public then discountenanced it and many of the States passed laws so regulating and restricting the rinks that they have been closed.

SWIMMING. Of this valuable exercise records are not frequent; and they are of little worth, because the various conditions of tide and running water are such as to make a fair record very difficult. Natoriums are now common in all the larger cities. The former practice was to have the bottom of the building open to the bottom of a stream. But, latterly, it has been customary to build a floor that can be raised at any angle by windlasses at the four corners. This is considered much safer for the bathers. The natoriums now float instead of being built from the bottom of the stream. An approved form consists of two pontoons running longitudinally, each 60 feet long and about 30 feet broad. The pontoons are divided by bulkheads into airtight compartments which would prevent the bathhouse from sinking in case of an accident. The pontoons are connected at the ends by stout timbers bolted and wedged with knees for braces. Upon this double boat a foundation and structure 80 feet square is erected. There is but one entrance, and that is from the outside. Small compartments, for use by the individual bathers, open by doors into the inner court. The movable floor allows any depth of water to be used, and also gives access for occasional cleanings.

For swimming the following directions are given. First, learn to duck without minding it; hold your breath and put your head under water several times whenever you bathe. The ducking will become less and less disagreeable, until the disinclination to go under water nearly or quite disappears. Some acquire the necessary indifference to being under water almost at once. When it is acquired, select a place where the water is just deep enough for the bather to sit upon the bottom with head and shoulders out. Then take a full breath, distending the lungs, and, placing the arms by the sides, lie down on your back. If unsuccessful, partially expel the air from the lungs and try again. After having found out by actual experiment how easy it is to lie down on your back under water, go out to the full length of your rope and, holding your breath, pull yourself in toward the shore, hand over hand, not letting your feet touch bottom on any account until your breath gives out or you run aground. When you can run yourself ashore with ease and certainty you will probably have discovered that most of the passage is made at or near the surface of the water, and possibly you will have learned to keep your balance and pull yourself ashore with your nose above water. When you can do this you can breathe through your nose during the passage, and as soon as you can breathe comfortably while hauling yourself ashore you are ready for the next step;

namely, try to pull yourself ashore rising one hand for the rope and paddling with the other. This is not a very easy thing to do, and before you accomplish it you will find yourself paddling with both hands and kicking with both feet—that is to say, swimming. As soon as you find that you can keep yourself right side up, and your eyes and nose above water, you have learned the great secret, and swimming, with the most approved and scientific stroke, will follow according to your opportunities and ambition.

These directions are based upon the well-established fact that no one can be a confident swimmer who is disconcerted at finding himself unexpectedly under water. Therefore the first thing to be learned is to catch the breath instinctively under any and all circumstances the instant you find yourself going under water. Strangulation occurs in consequence of drawing water with the breath into the air-passages, and even partial strangulation is unpleasant. The first thing, then, for the novice to learn is to instinctively keep water out of the windpipe. This can best be done by frequent voluntary duckings.

TENNIS, LAWN, is fully described in the *ENCYCLOPEDIA BRITANNICA*.

TOBOGGANING is a sport which has been recently imported into the United States from Canada. The remarkable spread of the sport in the Northern States is worthy of a brief notice. About the year 1875 the winter sports of the city of Montreal commenced to attract attention. These, including tobogganing, were made an annual feature of its social life. Since that time tobogganing slides have been erected in Saratoga, Troy, Albany, Burlington, St. Paul, and many other cities of the North.

A toboggan slide may be briefly described as follows: A frame of heavy timbers is erected to a height of from 50 to 60 feet. From one side of this frame a very steep slide, paved with ice, is arranged at an incline of about 45 degrees for perhaps 10 or 15 feet. The incline then changes so that it shall gradually approach the ground and run parallel with it. If the slide (as is usually the case) has been arranged near a hill-side, the runway is considerably longer. The object of the steep incline at first is to give the impetus to the toboggan at the start, where it is most necessary. The toboggan differs from the ordinary sled in being composed of flat boards turned up at the front end. A toboggan will carry from 2 to 6 or 8 persons. A modification of tobogganing, known in some of the Northern cities as "bobbing," is a cross between tobogganing and coasting. The "bob" consists, primarily, of two sleds joined by a long plank, upon which from 4 to 40 people can ride. In Vermont, and other of the New England States, a modified bob is used called a "traverse." This differs from the bob in that it has braces along the sides upon which to place the feet. Bobbing is practised in Albany and some other Northern cities.

WALKING was first publicly made a competitive exercise in the United States about the year 1868, when Edward P. Weston walked from New York to Chicago on a wager. The ensuing notoriety induced other walkers to take strides across the continent. Soon afterward matches were arranged within buildings upon tracks built specially for the purpose—none of them exceeding a third of a mile in circuit. In 1882 Fitzgerald made 582 miles in 6 days; and afterward Hazael made over 600 miles. These contests took place in the city of New York. In February, 1888, James Albert made 621 miles and 1320 yards in 140 walking hours, with only 19 hours and 21 minutes of the six days for resting. This record was broken in November, 1888, by Littlewood, who made 623 miles and 1320 yards within the six days. The second on the list made 605 miles in that time.

(F. G. M.)

SPOTTSYLVANIA, BATTLE OF. See WILDERNESS.

SPRAGUE, CHARLES (1791-1875), poet, was born in Boston, Oct. 25, 1791, his father having been one of the party that threw the tea into Boston harbor. The boy was educated at Boston, and at the age of 10, through an accident, lost the sight of his left eye. At the age of 13 he entered a mercantile house as clerk, and in 1816 became a partner. In 1820 he became teller in the State bank, and, on the establishment of the Globe bank, in 1825, he was appointed cashier, and held the office till 1865, when he withdrew from active life. He early manifested a taste for poetry, and for many years devoted his spare time to the study of the old English classics. Public notices were first drawn to him as a poet by his winning the first prize for the best prologue on the opening of the Park theatre, New York, and he achieved similar success at the opening of theatres at Philadelphia, Salem, and Portsmouth. In 1823 he won the first prize for the best "Shakespeare Ode," which was recited in the Boston theatre. In 1823 he delivered at Cambridge before the Phi Beta Kappa Society of Harvard a poem on "Curiosity" which has been considered his best production. In 1839 he pronounced the centennial ode at Boston on the 200th anniversary of the settlement of the city. Of his productions Elwin P. Whipple says: "His prologues are the best that have been written since the time of Pope. His 'Shakespeare Ode' has hardly been excelled by anything in the same manner since Gray's 'Progress of Poesy.' But the true power and originality of the man are manifested in his domestic pieces. 'The Brothers,' 'I see thee still,' and the 'Family Meeting' are the finest consecrations of natural affections in our literature." His *Prose and Poetical Writings* appeared at Boston in 1850, and other editions followed in 1855 and 1876. He died at Boston, Jan. 14, 1875.

SPRAGUE, WILLIAM BJEL (1795-1876), best known by his *Annals of the American Pulpit*, was born at Andover, Conn., Oct. 16, 1795. He graduated at Yale College in 1815, and studied theology at Princeton. He was ordained pastor of the Congregational Church of West Springfield, Mass., in 1819, and ten years later took charge of the Second Presbyterian Church, Albany, N. Y., to which he ministered for forty years. He was released from this charge in 1869 and retired to Flushing, L. I., where he died, May 7, 1876. In his early life he had published *Letters to a Daughter* (1822); *Letters from Europe* (1823); *Revivals of Religion* (1832); *Words to a Young Man's Conscience* (1848), and many sermons and commemorative discourses. At length, in 1852, he began preparations for his great biographical work, to contain sketches of prominent American ministers of nearly all denominations. Though its publication was somewhat interrupted by the civil war, the work was completed in 9 large octavo volumes in 1859. Volumes I. and II. comprise the Congregationalists; III. and IV., Presbyterians; V., Episcopalians; VI., Baptists; VII., Methodists; VIII., Unitarians; IX., United Presbyterians, Lutherans, and Reformers.

SPRING, GARDINER (1785-1873), Presbyterian minister, was born at Newburyport, Mass., Feb. 24, 1785. His father, SAMUEL SPRING (1746-1819), had been a chaplain in Arnold's expedition to Canada, and afterward pastor at Newburyport for forty years. He took part in founding Andover Seminary, and in organizing the American Board of Commissioners for Foreign Missions. Gardiner graduated at Yale College in 1805, and, after spending over a year in teaching in Bermuda, returned to New Haven to study and practise law. But he soon determined to enter the ministry, and, having studied theology at Andover, was ordained and installed pastor of the Brick Presbyterian Church, New York City, in 1810.

The early years of his pastorate were marked by frequent revivals. He took part in forming the American Bible Society in 1816, the American Tract Society in 1825, and the American Home Missionary Society in 1826. His pulpit power and influence steadily increased, and many of his sermons were published. In 1861 he was prominent in securing from the Presbyterian General Assembly (O. S.) resolutions giving moral support to the U. S. government's defence of the Union. After that year he had a colleague in the pastorate, but, though he preached less often, he retained his position till his death, Aug. 18, 1873. Among his publications were *Life of Samuel J. Mills* (1820); *Obligations of the World to the Bible* (1839); *The Power of the Pulpit* (1848); *The Mission of Sorrow* (1862); *Pulpit Ministrations* (1864); and *Personal Reminiscences* (1866).

SPRINGFIELD, the capital of Illinois, county seat of Sangamon Co., is 4 miles S. of the Sangamon river, and 185 miles S. W. of Chicago, at the intersection of the Chicago and Alton and the Wabash, St. Louis and Pacific Railroads. The State capitol, a marble building with granite portico, is 385 feet long by 296 wide, and stands in the centre of a square, which is surrounded by handsome blocks of business houses. The U. S. government offices are accommodated in a fine building. Springfield has also a fine State arsenal, 8 banks, 2 hospitals, 28 churches, 2 colleges, 3 academies, a public library, 4 daily and 10 weekly newspapers. Springfield is in a bituminous coal region, which gives rise to important industries. There are large iron-rolling mills, railroad shops, paper and woollen mills, planing and flour mills, a watch factory, and other factories. Springfield was laid out in 1822, was selected as the State capitol in 1837, and was made a city in 1840. It is governed by a mayor and a board of 18 aldermen. It has gas- and water-works and a paid fire department. Its population in 1880 was 19,743. Springfield was the home of Abraham Lincoln, and in Oak Ridge cemetery, near the city, stands the Lincoln monument, designed by L. G. Mead and costing \$264,000. Besides an obelisk, it comprises a catacomb and memorial hall.

SPRINGFIELD, a city of Massachusetts, county seat of Hampden Co., is on the Connecticut river, which is here crossed by four iron bridges and a wooden bridge to West Springfield. It is 98 miles west of Boston and is at the intersection of several railroads, which assist its commercial importance. Besides the level along the river bank, the city occupies part of an elevated plain extending eastward, and comprises three villages and post-offices besides the city proper. In the latter the streets are wide and well shaded with elm- and maple-trees. There are several public squares and a park of 100 acres. The city has a brown-stone post-office; a granite court-house, which cost \$500,600; city hall, city library; a Union railroad station, costing \$700,000; 9 banks, 3 savings banks, 2 private banks, and 3 insurance companies, a high school and 30 other schools, a cathedral and 30 churches, 3 daily and 8 weekly newspapers. The U. S. arsenal was established here in 1777 and in 1794 the armory was founded on Armory Hill. The buildings occupy a square of 20 acres, and about 400 hands are employed. During the war as many as 3400 were employed, and the daily product was 1000 finished arms. The arsenal has usually about 300,000 stands of arms. Springfield has also cotton and woollen factories, car-works, machine-shops, paper-mills, and manufactures of furniture, carriages, pistols, skates, organs, trunks, locks, picture-frames, buttons, needles, and jewellery. Springfield has gas since 1847, and electric light since 1882, and water-works, which bring a supply from Ludlow, 9 miles off, with three intermediate

reservoirs. It was settled in 1635 and was made a city in 1852. Its property is valued at \$39,861,550, and the tax-rate is 1.36 per cent. In 1885 it had 37,577 inhabitants, and has now 42,000, making it the eighth in size in the State. In the vicinity brown sandstone is quarried, and shipped over all the country.

SPRINGFIELD, a city of Missouri, county seat of Greene Co., is on the St. Louis and San Francisco Railroad, 238 miles W. S. W. of St. Louis. It is the most important town of Southwestern Missouri. It has a court-house, 15 churches, 3 banks, 2 daily and 5 weekly newspapers. Drury College, a Congregational institution, was established here in 1873. The industrial works comprise machine-shops, car-works, woollen and cotton mills. The population in 1880 was 6552, but it has since greatly increased.

SPRINGFIELD, a city of Ohio, seat of Clark county, at the confluence of Lagonda Creek with the Mad River, 81 miles N. N. E. of Cincinnati. Six lines of railway pass through the city, connecting it with Cincinnati, Cleveland, Sandusky, Columbus, Indianapolis, and more distant places. It has a fine county court-house, new government building, new city building, a handsome library structure, two opera-houses, and fine business blocks. Besides 15 public schools it has a young ladies' seminary and Wittenberg (Lutheran) College, with good building and spacious grounds, and a free public library. There are 38 churches, some of which are fine edifices, a free hospital, and children's home. Three daily and 6 weekly newspapers are published here. The city has 60 manufacturing firms, employing over 7000 workmen. The chief products are agricultural implements, among which their reapers, mowers, and graindrills (see AGRICULTURE) are especially noted. There are also produced sewing machines, bicycles, tricycles, water-wheels, iron fences, malleable iron, linseed-oil, etc. The city has good water-works, an efficient fire department, gas and electric lights, telegraph and telephone service, a park, good sewerage, street railways, and postal carrier-delivery. Springfield was laid out in 1801 and incorporated as the county seat in 1819, but its chief improvement has been since 1860. Its population in 1880 was 20,730, but it has since greatly increased. The Indian chief Tecumseh was born in this vicinity.

SPRUCE, the name usually given to that section of the botanical genus *Abies* (or, according to some botanists, to the separate genus *Picea*) the species of which are distinguished by pendant cones with persistent scales, and by the leaves being arranged all around the shoots; in distinction from the Firs, in which the cones are erect, the scales non-persistent, and the leaves placed in rows on opposite sides of the shoot. The Spruces are of slower growth than the Firs, and their wood much superior for commercial purposes, it being soft but tough, and well adapted to many uses. The Spruces are also often of handsome form and foliage, and several species are highly esteemed as ornamental trees.

In the eastern United States and Canada there are three species of considerable commercial importance, *Abies Canadensis*, the Hemlock Spruce; *Abies nigra*, the Black Spruce; and *Abies alba*, the White Spruce. (For a description of these species, see Fir in the ENCYCLOPEDIA BRITANNICA.) The Rocky Mountain and Pacific coast regions possess several species, most important among which is *A. Engelmanni*, the characteristic species of the mountains of Colorado. This is a large tree, from 75 to 150 feet in extreme height, and 3 to 4 feet diameter, its range extending through the Rocky Mountains to British Columbia and to Oregon. It is a handsome tree, with timber similar to that of *A. nigra*, covers the mountain-slopes from 5000 to 11,500 feet elevation, and at the medium height forms in Colorado

extensive forests of considerable density and great beauty. At its extreme elevation it is reduced to a prostrate shrub, which is, however, loaded with cones. *P. Engelmanni* is the most valuable timber tree of the central Rocky Mountain region, being much used for fuel, charcoal, and lumber, while its bark is rich in tannin.

A. Litchensis, the tide-land spruce, extends from Alaska to California, and forms extensive forests, from 10 to 50 miles wide, near the mouth of the Columbia River. It is a large tree, attaining a height of 140 to 180 feet, and 7 to 15 feet diameter, and is of great economic value, its wood being used for construction, fencing, boat building, cooperage, etc. *A. pungens* is a rare and local species, extending from the Wind River Valley to the mountains of Wyoming, Colorado, and Utah. It never forms forests. Among the species which have been classed as spruces may be named the huge Douglas Spruce,

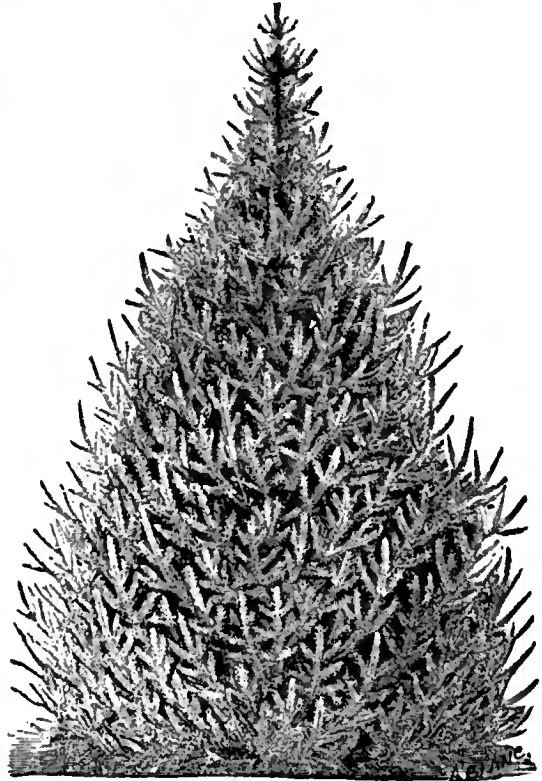

Norway Spruce.

which in its extreme growth is among the tallest trees known, it being said to occasionally, in Oregon, attain a height of 300 to 350 feet. Recent botanical authorities, however, remove this species from the genus *Abies*, and class it as *Pseudotsuga Douglasii*, it having peculiarities of seeming generic value which approach those of the Hemlocks. In addition to the native Spruces of America, several exotic species have been introduced as ornamental trees, principal among these being the Norway Spruce, *A. excelsa*, which in form and foliage is one of the handsomest of the conifere. (C. M.)

SPURGEON, CHARLES HADDON, eminent Christian preacher and worker, was born at Kelvedon, Essex, England, June 19, 1834. His father John and grandfather James had been pastors of Independent churches. With the latter Charles spent his childhood, already evincing a serious disposition and being pointed out as likely to be a successful minister. Returning to his father's house at Colechester, he attended school there, and when only fifteen be-

came an usher at Newmarket. In 1850 he became a Baptist, and soon began to preach with such force that in 1852 he was made pastor of a church at Waterbeach. In the next year he was called to supply New Park Street Chapel, London, and in a few months a sermon of his was printed, thus inaugurating a practice which has resulted in the circulation of millions of his discourses. The chapel, proving too small for the increased congregation, was enlarged, and in 1861 the Metropolitan Tabernacle was opened, having seats for 5500 persons. Though its cost exceeded \$150,000, it was free of debt. In connection with this church there are numerous missionary, educational, and philanthropic agencies. The Pastors' College, intended to fit young men for ministerial work, began in 1855, and has a special building, erected in 1874. The Stockwell Orphanage sprang from a gift of £20,000 made by a lady to Spurgeon for this work. At first boys only were admitted, but since 1879 girls also are received. There are now about 240 boys and 230 girls supported, the most needy having the preference. The church has also its almshouses and day-school, and carries on colportage in the villages of England. Mr. Spurgeon has an efficient helper in his wife, to whom he was married in 1856, and his brother, James Archer Spurgeon (b. 1837), has been his associate in the pastorate since 1863. His twin sons, Charles and Thomas, have become Baptist preachers, the former at Greenwich, England, the latter at Auckland, New Zealand. Spurgeon's publications comprise, *The New Park Street Pulpit*, *The Metropolitan Tabernacle Pulpit*, *The Treasury of David*, a commentary on the Psalms (7 vols.), *Lectures to my Students*, *John Ploughman's Talk*, and *John Ploughman's Pictures*. The last two, homely in style and pungent in matter, have attained a circulation of 350,000 copies. Mr. Spurgeon's religious monthly magazine, called *The Sword and Trowel*, gives information of the various enterprises in connection with his church. The power exerted by Spurgeon, both in the pulpit and through the press, has been abundantly acknowledged not only by those favorable to his methods but by those indifferent and hostile. The *London Times* has been led to ask why St. Paul's and Westminster Abbey should remain comparatively empty while this dissenter should gather around him 10,000 people every Sunday. The *Daily Telegraph* and the *Saturday Review* have borne testimony to his efficiency. His success is due to his intense earnestness and sincerity, assisted by his simple, idiomatic language and his impressive delivery. Fully convinced of the truth of his utterances, he presses the message of Christianity on the hearts of the people.

SQUASH, the name commonly given to several species of the gourd family, genus *Cucurbita*, the title being derived from the final syllable of the Indian name for the plant, *Askutasquash*. The words squash and pumpkin are used somewhat indiscriminately in the United States, large varieties of the squash being ordinarily called pumpkin, without attention to specific characters. It is very difficult, indeed, to define the species of squashes, or to trace the cultivated varieties to the original species, the plants hybridizing so readily as to confuse all distinctions. The squashes are said to be of wider variety in kinds, fitted for more varied uses, and found in a better state of perfection under all conditions of weather, than perhaps any other garden product. Being of tropical origin, their growth is consummated during the summer, yet the fruit of the late varieties can be kept, with a little care, through the winter, and until the following May. They are all of luxuriant and vigorous growth, and will do well in almost any soil, though they respond very readily to generous fertilization. They are, next to Lima

beans, the latest vegetable to be planted, light soils being best suited to their cultivation.

There are two broad varieties of squashes, the bush squashes, of early summer ripening, and the late or winter squashes. The vines of the bush or early varieties have lost much of their running habit, and grow in a somewhat bush-like compactness, while the late varieties have vines of 12 feet or more in length, which send down secondary roots at their joints. In planting, the bush squashes are sown in hills 3 or 4 feet apart, the running squashes 6 to 8 feet apart. Eight or ten seeds are sown in each hill, the plants being afterward reduced to three or four of the strongest. Squashes are grown extensively for market, and the early varieties are raised in large quantities in the vicinity of Norfolk, Charleston, and Savannah for shipment to the North, reaching market two or three weeks before the Northern squashes are ripe.

It is not positively known that there are any species of squashes native to the United States, though there is reason to believe that this is the case. Roger Williams and other early writers of New England speak of the general culture of some varieties by the Indians. One species, *C. orifera*, is found wild in Texas. It is cultivated principally for ornamental purposes, under the names of mock orange, orange gourd, etc., and is occasionally eaten young, as the egg-squash. Gray thinks it may be the original of all the crook-necked squashes, the vegetable marrows, and even the common pumpkins. There are very many varieties of squashes in cultivation, though it is difficult to keep any kind pure, on account of their readiness of intercrossing. Of the bush varieties those most commonly grown bear a fruit of partly hemispherical shape, with an expanded and flattened edge which is deeply and regularly scalloped. These vary considerably in color, are the earliest to ripen, and are planted almost exclusively for the first crop, while their hard rind adapts them well to shipment. The Summer Crook-neck is highly esteemed, and the best in yield of the summer varieties. It is about 8 inches long, tapering and curved toward the stem, the skin bright yellow in color, with warty protuberances. The Boston Marrow, which ripens about ten days after the above, has an orange-yellow, very thin rind, and is of unsurpassed flavor. The fruit is egg-shaped, with both ends pointed.

Of the fall and winter varieties the Essex Hybrid is of excellent flavor and is unexcelled in winter-keeping qualities. The Hubbard is far more extensively grown as a late variety than any other. It is of large size, often weighing 9 or 10 lbs., of bluish-green color, and of superior quality. In some of the Eastern States the Winter Crook-neck is largely grown for winter supply. The Mammoth Chili is a variety which attains an immense size, often weighing as much as 200 lbs. It is excellent for all purposes. In England the favorite variety of the squash is that known as the Vegetable Marrow, which is distinct in character from all the preceding. The fruit varies considerably in size, ranging from 9 to 18 inches in length, and from 4 to 6 inches in diameter. The skin is of a greenish-yellow color, the flesh white, soft, and of a rich flavor. We have named here but a few of the very many varieties of the squash, but the above are those most widely grown and highly esteemed at present. They are used largely on American tables, cooked as a vegetable, as a constituent of pies, and prepared in other modes, and form a very important member of our food products. (C. M.)

SQUIER, EPHRAIM GEORGE (1821-1888), traveller and archæologist, was born at Bethlehem, N. Y., June 17, 1821. In youth he worked on a farm, taught school, then edited country newspapers, and

studied engineering. Having removed to Ohio he became interested in the Indian mounds of that State, and with Dr. E. H. Davis undertook an exploration of them, whose results were published by the Smithsonian Institution. He next published *Aboriginal Monuments of the State of New York* (1849). In 1848 he was sent by the U. S. government as chargé d'affaires to the republics of Central America. His observations of this region and its remarkable aboriginal architecture were recorded in several volumes, among which are *Nicaragua: its People, Scenery, and Monuments* (1852). In 1853 he returned to survey a route for an interoceanic railroad, which, however, was never begun. He published *The States of Central America* (1857), which was revised in 1870; and a work on *Tropical Fibres* (1861). In 1863 he was sent to Peru as U. S. commissioner and explored the remains of the Inca monuments, but after his return to New York his labors in the preparation of an exhaustive work on the subject were interrupted by a mental disorder. After an interval of years he was able to publish, *Peru: Incidents and Explorations in the Land of the Incas* (1877). Still later he was again attacked by the mental disorder and unfitted for work. He died at Brooklyn, April 17, 1888.

STAMFORD, a borough and town of Connecticut, in Fairfield county, on Long Island Sound, and on the New York, New Haven and Hartford Railroad, 34 miles N. E. of New York. The harbor will accommodate vessels of 8 feet draught, and there is daily steam boat communication with New York. The town-hall is a fine building which cost \$140,000. There are 10 hotels, 2 national banks and 2 savings banks, 4 weekly newspapers, 8 churches in the borough, and 12 more in the town. Besides manufactures of drug-extracts, hats, Yale locks, and post-office outfits, there are iron and bronze foundries, sash and blind factories. The borough is lighted with gas, and has water-works and small parks. Its property is valued at \$10,000,000, its public debt is \$150,000, and its ordinary yearly expenses about \$100,000. It was settled in 1641 and incorporated in 1830. For two hundred years it preserved the aspect of a typical Puritan village, but since 1850 it has become more cosmopolitan. The town has an area of 10 square miles, of which the borough occupies one-sixth. Many citizens of New York have summer residences here. The town had in 1880 a population of 11,297.

STÄMPFLI, JAKOB (1820-1879), a Swiss statesman, was born in the province of Berne in 1820. He was of humble origin, but by energetic persistence acquired a good education. He studied law at Berne, became an advocate in 1843, and soon after entered actively into politics, becoming a leader of the radical party about 1845. He was elected president of the canton of Berne in 1849, and of the republic of Switzerland in 1858. The reforms introduced through his influence were the establishment of direct taxation and the abolition of all feudal burdens, while he vigorously opposed the influence of the Jesuits. In 1872 he was chosen one of the members of the Alabama arbitration commission, and gave his vote in favor of the United States. He died, May 15, 1879.

STAMP ACTS. See REVOLUTION, AMERICAN.

STANDISH, MILES (or MYLES), the Pilgrim-soldier, was born about 1584, in Lancashire, England, and claimed to be descended from the rightful heirs of Duxbury Hall, Lancashire. Froissart tells how, in the time of Richard II., the rebel Wat Tyler was slain by a "sqnyer of the Kynges called John Standyshe" who received knighthood for the deed. Longfellow refers to the feat in his "Courtship of Miles Standish:" "One of my ancestors ran his

sword through the heart of Wat Tyler." While yet a youth Standish entered the English army in the Netherlands and rose to the rank of captain. Though not a member of the Leyden church or congregation he accompanied the Pilgrims to Cape Cod Bay, New England, on board the Mayflower, whence on Nov. 21, 1620, sixteen armed men, "Everyone his musket, sword, and corslet, under the command of Captaine Myles Standish were despatched ashore on a second exploration." No one has described the captain's appearance and character so graphically as Longfellow:

"Short of stature he was, but strongly built and athletic, Broad in the shoulders, deep-chested, with muscles and sinews of iron. Somewhat hasty and hot (he could not deny it), and head-strong.

Stern as a soldier might be, but hearty and placable always, Not to be laughed at and scorned, because he was little of stature,

For he was great of heart, magnanimous, courtly, courageous."

During the first winter at Plymouth he lost his wife, Rose, and tradition tells that he employed his friend, John Alden, to negotiate his marriage with the winsome Priscilla Mullins, but the maid's suggestion, "Why not speak for yourself, John?" resulted in her marriage with the envoy. Standish was the champion, *par excellence*, of the infant settlement, defending it against the open and secret hostilities of the Indians. In 1622 a new colony was founded at Wessagusset (now Weymouth), and the Massachusetts Indians planned to destroy it. The plot was revealed by a friendly Indian, and Standish, with only 8 men, set out to its relief. By the counsel of their native well-wisher Standish decoyed the two chiefs, along with a half-brother of one of them, into a room, and there, after a desperate struggle, slew them. A battle followed, and the Indians fled. The head of Wituwamat, one of the chiefs, was set up at Plymouth, and this, with Standish's victory, struck terror into the savages. In 1625 he revisited England as agent for the colony, and returned next year with supplies. He then settled Duxbury—giving that name to the place after the English home of his race—and for the remainder of his life held the office of magistrate or assistant of that town. Plymouth despatched a vessel and force under Standish to compel the French to surrender Penobscot, from which, in 1635, they had driven away a party of Plymouth men, but the expedition proved a failure. In addition to being the military head of the colony, Standish was its counsellor in civil matters, and for many years its treasurer. Tradition says his second wife, Barbara, was a younger sister of his first wife, Rose. In 1877 a portrait of Standish, painted on a panel, with date 1625, and bearing his name and age (38), was discovered in a picture-store in Boston. It is now to be seen in Pilgrim Hall, Plymouth, where one of his swords is preserved, another being in the cabinet of the Massachusetts Historical Society. He died at Duxbury, Oct. 3, 1656, leaving a widow and four sons to whom, by his will, bearing date March 7, 1655, he left his property, valued at £350. A granite monument (founded in 1872) is erected to his memory on Captain's Hill, Duxbury, and is surmounted by a statue of the hero, "the first commissioned military officer of New England." (J. H.)

STANFORD, LELAND, railroad constructor and senator, was born at Watervliet, N. Y., March 9, 1824. His early life was spent on a farm, but, having studied law, he was admitted to the bar and began practice at Port Washington, Wis. In 1852 he removed to California and engaged in gold mining in Placer county. In 1856 he established a mercantile business in San Francisco, and accumulated a large fortune. In 1860 he was a delegate to the Republican national convention at Chicago. He was a

prominent promoter of the Pacific railroads, and in 1861 became president of the Central Pacific Railroad. He was elected governor of California in the same year. His energy and force of character were fully shown in the construction of the Pacific Railroad over the mountains in 1869. Subsequent years were devoted to the development of the business of the road and to the promotion of the material interests of California. In 1885 he was chosen U. S. senator. In memory of his only son he has given \$20,000,000 for the endowment of a university at Palo Alto, Cal. The corner-stone was laid, May 14, 1887, and the buildings are expected to accommodate students in 1889.

STANLEY, DAVID SLOANE, general, was born in Cedar Valley, Ohio, June 1, 1823. In 1852 he graduated at West Point and was brevetted 2d lieutenant in the Second Dragoons, and detailed for service in the survey of a railroad route along the 35th parallel. From 1855 till 1861 he served as a cavalry officer, almost constantly on the frontier, taking part in engagements against the Cheyennes and the Comanches. For a successful fight against the latter, near Fort Arbuckle, he was complimented by Gen. Scott in general orders, and in 1861 promoted to a captaincy. On the outbreak of the civil war he was sent to the field of active operations in Missouri, where he was engaged in several actions, and in September, 1861, was nominated brigadier-general of volunteers. At New Madrid he led a division, and the general in command reported that he was "especially indebted to General Stanley for his efficient and untiring zeal." He commanded the second division of the Army of the Mississippi at the capture of Island No. 10, and in this capacity took part in most of the skirmishes around Corinth and in the battle of Farmington. He was in the battle of Iuka (Sept. 19), for his conduct in which he was commended by Gen. Rosecrans, and in that of Corinth (Oct. 3-4), where he was exposed to the severest attack of the enemy, but stood fast when other parts of the line gave way. In November, 1862, he was made chief of cavalry in the Army of the Cumberland, and on the 29th promoted major-general of volunteers. He was in active service at the battle of Stone River, in the Tullahoma campaign, including the battle of Shelbyville, and in the many minor engagements of that army. He was in command of the Fourth Army Corps in Sherman's Atlanta campaign, and took part in the battle of Jonesboro, where he was wounded. During the month of October his command was engaged in following Hood, till on the 27th it was detached from Gen. Sherman's force and ordered to strengthen Gen. Thomas, who had been despatched to Nashville to resist the invasion of Tennessee. On his march toward Nashville he was engaged in frequent affairs, distinguishing himself particularly in the action at Spring Hill. On the Fourth and Twenty-third Corps (of which he was now in command) arriving at Franklin, Nov. 30th, it made a stand, and a desperate hand-to-hand conflict ensued, in which he was severely wounded; refusing, however, to leave the field till a notable victory had been gained. He received frequent promotions, and for his skill and bravery here was brevetted major-general in the regular army. After being disabled for two months he rejoined his command, and, after the war, led it to Texas. In February, 1866, he was mustered out of the volunteer service and resumed his command in the regular army, as colonel of the Twenty-second Infantry. In 1872-73 he was in command of the Yellowstone expedition, and his favorable reports in regard to the hitherto unknown Dakota and Montana did much to promote emigration thitherward. In 1874 he was with his regiment at the lake stations; in 1879 he moved to Texas, and effectually checked

Indian raids in the West. In 1882 he was ordered to Santa Fé, and placed in command of the district of New Mexico. In March, 1884, he was assigned to the Department of Texas, with the rank of brigadier-general in the regular army.

STANLEY, HENRY MORTON, explorer, was born near Denbigh, Wales, in 1840. His name was then John Rowlands, and at the age of three he was sent to the poor-house at St. Asaph, where he stayed till he was thirteen. He was then employed as a teacher at Mold, Flintshire, but a year later shipped as a cabin-boy for New Orleans. There a merchant named Stanley gave him employment and eventually adopted him. But the merchant died intestate, and his property passed to other heirs. Stanley then led a roving life among Indians and California miners until the civil war broke out. He enlisted in the Confederate army, but, being soon taken prisoner, offered to take service on the other side. He was sent to the iron-clad Ticonderoga, and there became acting ensign. At the close of the war he went to Crete as correspondent for the *New York Herald*, but soon left and travelled in Turkey and Asia Minor. Returning, he visited Wales, and gave a dinner to the poor-house children at St. Asaph. In 1867, after a visit to the United States, he went as a *Herald* correspondent to Abyssinia. By sending to London the news of Lord Wolseley's victory before the official despatches arrived, Stanley attracted universal attention to his merits. In 1868 he was employed in reporting the war in Spain. In 1869 Mr. James G. Bennett, the proprietor of the *Herald*, conceived the idea of sending the adventurous Stanley into Central Africa in search of Dr. Livingstone, who had been reported to be killed in 1866, but whom Mr. Bennett believed to be still alive. Stanley went first to the East, visiting Constantinople, Egypt, Jerusalem, and crossing Persia to India, which he reached in August, 1870. Thence he sailed in October for Zanzibar, having decided to follow in Livingstone's track. He organized an expedition of 192 men, divided into five caravans, the first of which started inland on February 18, 1871, and the last of which he accompanied on March 21. His objective point was Ujiji, and he had resolved to reach Unyanyembe, the half-way house, within three months. In the middle of April he met an Arab chief, bound eastward, who informed him that Livingstone was at Ujiji. During the first month much of Stanley's route lay through the jungle, so that his average day's march was only four miles, while the carriers and other natives hired to accompany him frequently gave trouble or tried to escape. Still worse were his difficulties with the Englishman and Scotchman whom he had engaged as his chief assistants. But, in spite of fever and insect-plagues, as well as the troubles from treacherous followers and extortionate chiefs, he pushed on, and in June reached Unyanyembe. Owing to his sickness and a tribal war he remained in this vicinity till the end of August, though he heard again that Livingstone was at Ujiji, 400 miles distant. Across the fertile regions of the interior, peopled by naked savages, he toiled on, paying tribute to chief after chief for permission to pass his little district. At last, on Nov. 10, 1871, he sees the port of Ujiji on the great lake Tanganyika. At his order his band fire their guns and display the American flag, and march into the town. Livingstone's servants soon salute him, and conduct him to the object of his toilsome search. The veteran missionary and the adventurous correspondent exchange greetings. They spent four months together, but Dr. Livingstone refused to return to Europe, as his work of exploration was not yet done. He accompanied Stanley on his return as far as Unyanyembe, to which place stores had been forwarded for both parties. Though

floods greatly impeded the way, Stanley pressed on, and in May, 1872, was again in Zanzibar, where he found another expedition, organized under the auspices of the Royal Geographical Society, making preparations to start. As, however, the immediate object of finding Livingstone had been already accomplished, this expedition was abandoned for the time, but was taken up again by Lieut. Verney L. Cameron. (See *AFRICA* in this work.) Stanley arrived in England in July, 1872, and gave an account of his expedition before the British Association in August. Honors of all kinds were abundantly bestowed upon him, and in November he published his narrative, *How I Found Livingstone*. Before he left Africa Stanley had despatched a caravan with stores for Livingstone, but it spent five months in reaching him. Then the veteran resumed his work, but the country he explored was flooded and he eventually succumbed to dysentery, dying on May 1, 1873.

Stanley's next famous expedition is described under *AFRICA*. In this, starting again from Zanzibar in the autumn of 1874, he turned off to Victoria lake, which he thoroughly explored, then made his way to Ujiji, crossed to the Lualaba river, and, there embarking, proved its identity with the Congo by sailing down that mighty stream to the Atlantic Ocean. He reached the coast in August, 1877, after perils far surpassing those of his first famous expedition. His second heroic enterprise and the wonderful geographical discoveries which were then accomplished are narrated in *The Dark Continent* (1878). He went again to Africa in 1879 under the auspices of the African International Association, of which the King of Belgium was the chief patron, to explore the basin of the Congo river (*q. v.*). In the course of four years Stanley had established trading stations along the river for a distance of 1400 miles, and founded a government for the region.

Toward the end of 1886 Stanley undertook an expedition, partly at the expense of the Egyptian government, for the relief of Emin Pacha, who had seized the southern part of the territory claimed by Egypt. Leaving England in January, 1887, he gathered in Zanzibar a force consisting of 620 natives of that country, with 74 other Africans and 9 Europeans. He also had the help of Tippu-tip, the greatest slave-dealer of Central Africa. King Leopold of Belgium had furnished several steam-boats for use on the Congo. Stanley embarked on these at Stanley Pool on April 30, 1887. Since that time there have been rumors of his death, and again of his safety, but the facts are not yet positively known.

STANTON, ELIZABETH CADY, an earnest advocate of "Woman's Rights," was born at Johnstown, N. Y., Nov. 12, 1816. Her father, Daniel Cady, was an able and learned lawyer, who for years held the office of judge in Fulton county. His daughter, while still a child, spent much time in his office, where she heard many instances of the unjust discrimination of the laws against the property rights of women. Her indignation was early aroused by this, and was increased by the little consideration shown to girls as compared with boys. Her father manifested a superior regard for his son, and when the latter died was inconsolable, though he had five daughters. "I wish you were a boy," he said with a sigh to his daughter Elizabeth. "Then I will be a boy, and will do all my brother did," she replied. In pursuance of this resolution she determined to learn Greek, and the art of managing a horse, conceiving that learning and courage were the principal manly characteristics. She studied Greek, Latin, and mathematics, winning in the first-named study a Greek Testament as a prize, and afterward graduated in the Johnstown Academy at the head of her class. Her heart was set on entering Union College, where her brother

had been educated, and on learning that girls would not be admitted her vexation and indignation were great. She afterward studied at Mrs. Willard's Seminary in Troy. On reaching maturity the thoughts which had been fostered in her girlhood showed themselves in the life of the woman. She became an ardent advocate of the anti-slavery cause, and in 1839, when 23 years of age, was married to Henry B. Stanton, an eloquent anti-slavery orator.

Her husband had been chosen as a delegate to the World's Anti-slavery Convention, which met at Freemasons' Hall, London, June 12, 1840, and thither the newly wedded couple proceeded. Many women-delegates had been sent from America to the convention, but owing to prevailing notions about women, they were not permitted to take part in its deliberations. This exclusion excited much indignation, and added to Mrs. Stanton's feeling of the injustice done to her sex. While here she formed a warm friendship with Lucretia Mott, one of the most highly respected advocates of the reform upon which she had set her heart. Among the Englishwomen excluded from the convention were Elizabeth Fry, Mary Howitt, and Amelia Opie. On her return to America Mrs. Stanton resolved to devote her life to resisting the injustice shown, in several forms, to her sex; and in pursuance of this resolution she called, in June, 1848, at her own instance, a public convention of women at Seneca Falls, N. Y., in which city she then resided. This was the pioneer "Woman's Rights Convention" (known under that name), but Mrs. Stanton went in her views beyond all the other delegates in resolving to include woman's suffrage among the rights demanded. Her husband and Lucretia Mott strongly objected to her purpose in this direction, and at the opening of the convention she found only one delegate, Frederick Douglass, to support her novel demand. She had never before spoken in public, but developed an excellent ability in oratory, and, aided by Mr. Douglass, carried all her resolutions, that demanding the ballot included, through the convention. The announcement of this convention made a great sensation throughout the country. All the papers commented upon it, generally with ridicule, but Mrs. Stanton went persistently to work to advocate her views before the women of America. Two years after the convention Miss Susan B. Anthony, who had at first treated the demand for the ballot as ridiculous, became her friend and co-worker, and together they have spent their lives in ardent advocacy of this cause.

In 1866 Mrs. Stanton, then living in New York city, offered herself as a Congressional candidate to the voters of the 8th district. Out of 23,000 votes cast she polled exactly 24. In 1868 she, in conjunction with Parker Pillsbury, Miss Anthony, and others, started *The Revolution*, a journal in the interests of women's rights. This journal was finally merged in *The Liberal Christian*, an organ of Unitarianism. After giving up her editorship of *The Revolution* Mrs. Stanton devoted herself for 14 years to public lecturing. She is a happy and ready speaker, and by her advocacy did much toward the advancement of the cause she had so much at heart.

Apart from this exhausting work she compiled, in her residence at Tenny, N. J., a *History of Woman Suffrage* (3 vols. of 1000 pages each), embracing documentary evidence and biographies of its leading advocates. In 1882 she went to France on a visit to her son and his wife, and in 1883 held conferences in England with John Bright and others on her favorite theme. Mrs. Stanton has a son living in France, and a daughter residing in England, and has in all five sons and two daughters. The social reforms which she advocates have made remarkable progress during the forty years which have elapsed since the first convention at Seneca Falls. The property rights of

women have been placed on a level with those of men in some States, and have everywhere improved, while the demand for the ballot has gained too wide a circle of advocates to be any longer considered ridiculous, and has been granted in regard to school-board elections in some States, and in all municipal elections in the State of Kansas.

Her husband, HENRY BREWSTER STANTON (1805-1887), lawyer and journalist, was born at Pachaug, Conn., June 27, 1805. He removed to Rochester, N. Y., in early life, and engaged in journalism and politics. After being clerk of Monroe county for three years he went to Lane Theological Seminary at Cincinnati, in 1832, and there took part in the anti-slavery movement. He devoted years to this cause, and in the meantime, having married Miss Cady, went with her to London in 1840, and then made a tour in Great Britain, Ireland, and France. In 1847 he settled at Seneca Falls, N. Y., and was admitted to the bar, but was still active in urging temperance and other social reforms, as well as in anti-slavery work. He published *Reform and Reformers in Great Britain and Ireland* (1849). His chief work was done through the daily press, to which he was a constant contributor. He died in New York City, Jan. 14, 1887. Soon afterward a volume of his *Random Recollections* was published. (C. M.)

STARCH. A very considerable variety of plants yield commercial starch, though the principal supply is obtained from wheat, maize, rice, and potatoes. The manioc-root is the source of the useful nutrient variety known as tapioca; the root of several species of *Moranta*, of arrowroot; and the pith of very many of the palms, of sago. These latter, however, are tropical productions, and the ordinary starch of commerce comes in great part from the substances first named. Corn- or maize-starch is a product of American inventive industry, and was first produced in 1842. Previously wheat, barley, rice, and potatoes had yielded the world's supply of starch. Potato-starch was first made in the United States in 1802, the industry being introduced by John Biddis, of Pennsylvania. It in time became an important product, and a large number of starch factories were built, especially in the cotton-manufacturing districts, the starch being largely consumed in this industry. A number of wheat-starch factories also were built. In Europe wheat constituted the principal source of starch, the product being very considerable, particularly in England and France, whose cotton factories consume a large percentage of the supply. Among the several substances which have been used abroad as starch producers may be named horse-chestnuts, which have been employed for this purpose in France. The bitter principle is removed by the use of sodium carbonate.

In 1842 Thomas Kingsford, superintendent of the wheat-starch factory of W. Colgate & Co., in New Jersey, began to experiment with Indian corn, and soon satisfied himself that this grain was well adapted to serve as a superior commercial source of starch. His conviction was communicated to others, and some capitalists built a factory for him at Oswego, N. Y., in 1848, this location being chosen from the ease of getting a large supply of corn from the West by water-carriage, while it was comparatively convenient to the great commercial and manufacturing centres. The industry prospered from the start, and the factories have grown until they cover 10 acres of ground-surface, treat over a million bushels of corn annually, and yield an annual product of more than 20,000,000 lbs. of starch. The great prosperity of the Oswego factory gave instigation to another great concern, the Duryea Brothers' corn-starch manufacturing establishment at Glen Cove,

Long Island, which was founded in 1858, and has at present a yield nearly or quite equal to that of the Oswego factories. These two concerns are now the largest starch-manufacturing establishments in the world. As early as 1860 they had brought to an end the importation of European starch, and soon after they began to compete with the factories of Europe for the starch commerce of the world. They have received the first prizes at international exhibitions, and the demand for their product has steadily grown, the exportations of American starch increasing from 1,000,000 lbs. in 1864 to 7,400,000 lbs. in 1887.

Corn-starch is made in the United States by soaking the corn in water containing caustic soda and hydrochloric acid, to dissolve the gluten, grinding, washing on sieves, and finishing by various processes. Each of the two great establishments employs its own methods, and no effort is made to recover the gluten as a food product, as in the European wheat-starch factories; but this, with other by-products of the grain, is sold as food for domestic animals. The starch is prepared in three forms, for three separate purposes. The first is that known as "Maizena," in England as "prepared food," being pulverized corn-starch intended for culinary purposes, and as food for infants and invalids. The second is the refined starch prepared for laundry use; the third, sizing starch for use in cotton factories and other industries.

The success of the factories named has led others into the business, and there are many smaller corn-starch factories now established. The establishment of this industry, however, has not done away with the production of wheat-starch, which is made in the United States on a considerable scale. Potato-starch is also largely manufactured, there being several factories at Stowe, Vt., and Watertown, Mass., some of which consume 20,000 bushels of potatoes annually, the yield averaging 8 lbs. of starch to the bushel. Rice-starch is largely manufactured in England, France, and Belgium, but not in the United States. In regard to the statistics of the American starch industry, there exist no general ones later than those of the census reports, and these are lacking in detail. In 1870 the number of starch factories in the United States were reported as 195, with a total product valued at \$5,995,000. In 1880 the factories had decreased in number to 139, but the product had increased to \$7,477,742. This was principally produced in three States, the yield of New York being \$3,328,102; of Ohio, \$1,754,710; and of Indiana, \$1,276,880. No other State produced largely. The business is steadily increasing, and is probably destined to attain a great development in the future, the immense yield of corn in this country giving an almost unlimited supply of material. The proportion of starch in the various grains is the following: Maize, 60 to 80 per cent.; wheat, 60; rye, 60; oats, 46; barley, 57; rice, 61. Potatoes yield 62 per cent. Of these various substances the high yield of maize seems to adapt it particularly to starch production. As to the uses of starch, the following are the principal: It is used for stiffening cotton and linen cloths, and as a sizing for paper and various other articles; for making paste, hair powder, dextrine, glucose, etc.; in medicine, to dilute and otherwise modify various articles of the materia medica; in surgery, in the preparation of splints and bandages; in the chemical laboratory, for the detection of iodine; for stiffening purposes in the laundry; and as a nutritious and agreeable article of food, for which its use is rapidly increasing. For the last-named purpose corn-starch is of high value. (C. M.)

STARK, JOHN (1728-1822), general in the Revolutionary war, was born at Londonderry, N. H.,

Aug. 28, 1728. In 1736 his father removed to Derbyfield, now Manchester, in that State, where young Stark was employed in farming, with intervals of hunting, till April 28, 1752. On that day, while out hunting, he was taken prisoner by a party of St. Francis Indians, in whose hands he remained a captive for six weeks, being finally set free on the payment of \$103 ransom. While with the Indians his frequent exhibitions of courage and independence of spirit made him very popular, and he was adopted into the tribe. In 1755 he was appointed lieutenant in Rogers' company of rangers, with which he served in the campaigns of that and the following year. In January, 1757, the corps to which he was attached, while returning from an expedition, was attacked by a strong body of French and Indians near Ticonderoga and a sanguinary conflict ensued, ending in the repulse of the colonists. The management of the retreat fell to him, and it was effected with great skill and prudence. Soon afterward he was made captain of rangers, and in 1758 took part in Abercrombie's attack on Ticonderoga. In the following spring he joined Amherst's army, and was present at the reduction of Ticonderoga and Crown Point.

At the end of the French war Stark returned to his farm, and remained there till the beginning of the Revolutionary troubles, when he was made a member of the Committee of Safety, and on learning of the battle of Lexington immediately repaired to Cambridge. Here he was made colonel of a regiment of New Hampshire troops, and took part with them in the battle of Bunker Hill, where his men were stationed behind a rail fence at the left of the line. They held their ground firmly, and repeatedly repelled the enemy with great loss, but were forced to retreat when the other portions of the line were taken. At the close of the campaign in the North, in 1776, he joined Gen. Washington, and in the battle of Trenton commanded the vanguard of the army. In the subsequent engagement at Princeton he played an active and prominent part. In the promotions that followed, however, Stark was overlooked and, feeling aggrieved, he resigned and returned to his farm in April, 1777. He was not left long at rest. The advance of Burgoyne from Canada began in June, and fort after fort was taken as he advanced south by the Lake Champlain and Lake George route. The council of New Hampshire at once commissioned Stark to raise a force to guard the frontier, and he quickly found himself again in active service. Burgoyne sent a detachment under Col. Baum to seize the supplies which the Americans had collected at Bennington, Vt. Gen. Stark marched rapidly to save these stores, and, finding Baum intrenched at a point near Bennington, attacked with great energy. It was at this time that he inspired his raw troops with the speech that has become historic: "There are the red-coats; we must beat them to-day, or to-night my wife sleeps a widow." His spirit was seconded by the valor of his men, the regulars were severely defeated, and a second force that was marching to Baum's assistance suffered the same fate, the British loss in these two actions exceeding 600 men. Yet more important was the saving of the stores, of which Burgoyne stood sadly in need, and the want of which aided in the eventual total collapse of his expedition.

For this gallant action Congress voted thanks to Gen. Stark on Oct. 4, 1777, though it had just before passed a vote of censure on him for disobeying Gen. Lincoln's order to march to the west of the Hudson, a step which would have left Baum's raid unopposed. He was commissioned major-general, and in September joined Gates and contributed to the success of the campaign. In 1778 he was placed in charge of the Northern Department at Albany, and in October of that year joined Gates in Rhode Island.

In May, 1780, he joined the army at Morristown, and was present at the battle of Springfield, being again placed in command of the Northern Department in the spring of 1781. This ended his army service, and he returned to his farm at Manchester, N. H., where he died, May 8, 1822, Congress having voted him in 1818 a pension of \$60 per month.

STATE-MILITIA. The militia of each of the States of the Union is an essentially State institution regulated by State laws. But by the provisions of the Constitution of the United States and the laws of Congress enacted to carry those provisions into effect, the militia of each State is, to a certain extent, subject to Congressional regulation and, under certain circumstances, is required to render service to the general government. This twofold relation—on the one hand to the State, on the other to the Union—gave rise, during a considerable portion of our national history, to much discussion, to angry disputes, and often to serious embarrassments. Partly by the logic of events, partly by the decisions of our highest judicial tribunals, these questions may all be regarded as now practically settled. A brief sketch of the history of the militia of the United States, of the nature of the questions above referred to, and of the manner of their settlement is necessary to a full understanding of the character and availability of the militia as a military force and of its present condition and strength.

When the Continental Congress proclaimed the independence of the colonies in the famous Declaration, the only military force of which it could avail itself in order to maintain that declaration was the militia. All the regular soldiers in the country and all the men who had received a scientific military education were on the side of the Crown. But, on the other hand, there was probably no country in the world where so large a proportion of the common people had a practical acquaintance with the duties of the soldier and so many of its educated men were fitted to change from the duties of peace to those of war. The long contest with the Indians and the French had imbued the people with the military spirit, and familiarized them with the dangers and hardships of war, while to large numbers of the men of ability that contest had been the school in which they had acquired a military education. Washington was a graduate of no military college, but he had acquired the theory and practice of war by years of service alongside of regularly educated British officers, and he was only the most illustrious type of a class. After the conclusion of the Revolution the mass of the people gladly returned to the pursuits of peace, but the military spirit was kept alive partly by tradition and partly by the spectacle of the great wars in Europe going on almost continually during the next generation. The drill and efficiency of the militia was far better preserved than it was a half-century later.

The Constitution of the United States, adopted in 1789, gave Congress the power "To provide for calling forth the militia to execute the laws of the Union, suppress insurrections, and repel invasions." These words conferred upon Congress the power of doing for the Union, as a whole, that which each State in its individual capacity could do for itself. They state briefly but clearly the primary reasons for the existence of a militia. But the Constitution further gave to Congress the power, "To provide for organizing, arming, and disciplining the militia, and for governing such part of them as may be employed in the service of the United States, reserving to the States respectively the appointment of the officers, and the authority of training the militia according to the discipline prescribed by Congress." Further, the Constitution provides that, "The President shall be commander-in-chief of the militia of the several

States when called into the actual service of the United States."

The first act of Congress in regard to "organizing, arming, and disciplining" the militia was passed in 1792; but this, as well as subsequent acts, aimed at little more than to secure a tolerable degree of uniformity among the militia of the different States and a certain amount of agreement with the arming and disciplining of the regular army. In all other important respects the authority of the States was not interfered with.

The war of 1812-14 raised a number of questions as to extent of the power over the State militia conferred upon the general government by the Constitution.

Some maintained that the power conferred on the President to act as commander-in-chief of the State militia when in the actual service of the United States was a power personal to himself and could not be delegated; and as the appointment of officers had been reserved to the States, the militia, even when in the U. S. service, were under no obligations to obey anybody but the State authorities or the President in person. The governor of Vermont went so far as to claim the right to order the militia of that State to return home if, in his discretion, he thought they were more needed at home than in front of the enemy who had invaded a neighboring State. But the decisions of the U. S. Supreme Court and the precedents established by the exigencies of the great civil war of 1861-65 have settled it, probably for all time, that from the moment the militia are mustered into the U. S. service they are, until the expiration of their term of service, as much under the control of the general government, for the purposes which they were called out to aid in accomplishing, as the regular army itself.

The conclusion of the war of 1812-15 and the overthrow of Napoleon Bonaparte were followed, both in America and Europe, by a period of peace extending over a third of a century. The war with Mexico was not a war "to enforce the laws of the Union, to suppress insurrection," nor "to repel invasions," and it consequently afforded the general government no occasion and no opportunity for calling out the militia. No such call was made until the breaking out of the great civil war in 1861. During this long period the interest of the people at large in military affairs and their knowledge of the art of war gradually decayed. The annual meetings for instruction in drill and discipline, the so-called "training days," became mere farces. They were regarded as a sheer waste of time or as something worse, occasions of drunkenness and revelry, profitable only to peddlers and gamblers, and went out of fashion.

When the great civil war broke out each State had upon its statute books an elaborate code of laws in regard to the militia. But by the great body of the people, and especially among the country-people, those laws had long been practically ignored. In most of the large cities one or two militia organizations existed. Some of these, in the accuracy of their drill, the precision of their movements, and the completeness of their appointments, would have compared favorably with the best regiments of any regular army in the world. But such organizations were wholly exceptional.

It was under these circumstances, as regards the condition of the militia, that Pres. Lincoln, on April 15, 1861, issued his first call for 75,000 men for three months' service. The enthusiasm of the people was very great. Had the President called for twice that number they would have been easily obtained. The quotas of the loyal States were quickly filled out. Most of those States, when their quotas were filled, refused to receive any more; other States offered to the general government the services of

far more than they were called upon to furnish. Massachusetts was ready with two and a half times, Rhode Island with four times, Connecticut with three times, Pennsylvania with 60 per cent., and Missouri with three times more than they were asked for. The great majority of the men were intelligent, brave, and eager to do their duty; but it would probably be an exaggeration to say that 10,000 of the 75,000 had any more knowledge of the duties of a soldier than is possessed by every intelligent citizen of full age. But there was something worse than this. The officers were generally as ignorant as the men. It is not possible here, nor is it necessary, to enter into details. The disastrous result of the first battle of Bull Run was necessary in order to convince the people that the attempt to improvise an army, in a few weeks' time, out of men taken from the office, the farm, and the factory, is, in modern warfare, but a waste of treasure and of blood.

The civil war also demonstrated another proposition. If its earlier events proved that untrained troops led by untrained officers, no matter how great their enthusiasm and bravery, were of small account, its subsequent course showed with equal conclusiveness that of all soldiers the well-trained "citizen-soldier" is the most efficient.

The greatest difficulty experienced in the earlier stages of the civil war was the lack of competent officers. Given a regiment in which the commissioned officers all thoroughly understand their duties while all the rest of the regiment consists of men strong and willing, though without knowledge and experience in military affairs, and it can be brought to a high state of discipline and efficiency in a comparatively short time. But where officers as well as men are obliged to learn their business after being mustered into service, the time required increases in an appalling ratio. To educate officers by means of actual service in time of war is a very costly operation. A large number of militia officers during the civil war achieved high distinction, but as a rule they were those who, from natural inclination, had devoted much time, before entering the service, to the study of military science and to practice in organized bodies of militia; or they were men of far more than average abilities, animated by an enthusiasm and determination which no obstacles could oppose.

One of the most remarkable citizen-soldiers, probably in the opinion of professional military men the most remarkable, developed by the civil war was Gen. Alfred H. Terry, who captured Fort Fisher, and at the close of the war was appointed a major-general in the regular army. He entered the service as a colonel, but it would be a great mistake to suppose that he passed, without preparation, from his office to his colonelcy. On the contrary, in his boyhood he had a strong inclination toward everything military. He served in the militia before the war with a kind of serious zeal. From youth to manhood he devoted much of his time to the study of military science. During the Crimean war he visited Europe for the express purpose of seeing military operations on a large scale as conducted in actual warfare. The consequence was that when he led his regiment to the field there was probably no graduate of West Point, no colonel in the regular army, who knew more thoroughly and completely what he ought to do and how it ought to be done.

The experience of our civil war appears to justify the conclusion that, in a free country, the maintenance of a great standing army imposes upon the people a burden at once enormous and unnecessary. With suitable legal provisions and at a comparatively small expense voluntary organizations sufficient both in numbers and discipline can be maintained to meet any sudden emergency and to insure time for pre-

nation for greater crises, provided that certain conditions are fulfilled. The most important of these conditions—indeed, the only indispensable ones—are the cultivation among our youth of a greater interest in military affairs and a greater dissemination of military knowledge among our educated young men. This is not the place to enter upon a discussion of the methods by which these objects are to be attained. The experience of the civil war demonstrated, in the most brilliant and conclusive manner, the thoroughness and completeness of the professional military education imparted by our national school at West Point. But in order to render speedily available, whenever occasion requires, the vast yet dormant and formless military power of our nation, there should be a far larger number of our citizens, than there is at present, who possess a military education somewhere intermediate between the perfection of West Point and that ignorance of the most rudimentary duties of a private and the most elementary principles of military science that characterizes the great mass of our educated young men. Among the measures which might be adopted to accomplish this purpose, the recommendation of Adjutant-General R. C. Drum of the U. S. Army, in his annual report for 1888, that military science should be made a part of the curriculum of our colleges and universities and that all students who are physically qualified should be required to attend lectures, recitations, and drills, is worthy of the most serious consideration.

By the laws of the United States all able-bodied male citizens between the ages of 18 and 45 years, with the exception of such as are exempted by State laws, are bound, when called upon, to do military duty. Thus the liability to render military service extends over 27 years of the citizen's life; but, should peace prevail, not one man in a hundred will ever even play soldier for an hour. The active militia is composed entirely of volunteer organizations. Their discipline must conform to that of the regular U. S. army. Almost everything else is regulated by State laws. The military codes of the different States vary considerably in matters of detail. In certain general features, however, there is substantial agreement. The term of service is generally five years. In order to induce men to enlist in such organizations certain privileges are conferred upon their members both during their term of service and after its expiration. One of the most common of these privileges is exemption from the performance of jury duty. But the State relies chiefly upon the fact that a large number of its citizens believe that they can manifest their devotion to law and order and prove their love of country in no other way so conclusively as by becoming members of some military organization. The State also relies upon the strong desire, which is innate in many men, to participate in military display and to receive their share of the admiration which the general public, male and female, always extends to a handsome, well-drilled military body. In many cases, also, membership of such a body is, to a certain extent, a mark of social distinction. In almost all our large cities there is one, in some of the larger cities more than one, militia regiment of which most young men would be proud to say they were members.

The amount of actual service required by the State in the course of a year does not generally exceed one week; but, of course, any organization which makes any pretensions to military excellence devotes, of its own accord, much more than this amount of time to drill and discipline.

The amount of money appropriated by the State to the support of the militia is very small. Indeed, membership of a militia regiment or company is always a source of individual expense; in some cases,

of very considerable expense. The cities often expend far more than the State upon regiments composed of their own citizens. They do this partly from municipal pride and partly in order that the civil power, in cases of riotous disturbance too extensive for it to cope with, may have at hand a military force upon which it can call for aid in suppressing disorder and maintaining the public peace. In such cases the military is entirely subordinate to the civil authority. No shot can be fired until the mayor, sheriff, or other authorized civil officer gives permission.

The total number of citizens belonging to militia organizations is limited by law. In proportion to the whole population the number is very small. In the great State of New York, with a population exceeding 6,000,000, the number is limited to 20,000. There is nothing in the whole organization of society and the States of the Union is more strikingly illustrated. In Germany, in time of peace, every male citizen not physically incapacitated, is obliged to spend some of the best years of his life in continuous military service. In the United States, in time of peace, only a very small fraction of the citizens are permitted to enter the military service of the State, and then only in such a manner as to hardly constitute an interruption to their ordinary avocations. If any number of citizens beyond the legal limit should desire to form a military organization they can do so in the same manner as they form athletic societies or base-ball clubs, according to their own rules and at their own expense. Such a military club, no matter what it might call itself, and no matter how complete might be its appointments and how perfect its discipline, would no more be a part of the legal military force of the State than the New York Yacht Club is a part of the United States Navy.

According to present regulations officers of the regular U. S. army are detailed to act as professors of military science and tactics in universities, colleges, and schools under prescribed conditions. During the year ending Sept. 30, 1888, forty institutions in different parts of the Union availed themselves of this opportunity of giving instruction in military science, with practice in military drill, to such of their pupils as chose to receive it. The whole number of students over 15 years of age attending these institutions was 7791. Of this number about 4000, or 51 per cent., attended infantry drill. During the previous year the same system had been pursued. The total number of students was less, and only 49 per cent. attended the drills. Should the interest of the students in military matters continue to increase in the same ratio and, above all, should the recommendation of Adjutant-General Drum to make attendance upon the lectures and drills of these officers obligatory upon all students be adopted, it must, in a few years, have a marked influence upon the military efficiency of the militia.

According to the laws of several of the States, the State-militia is required to go into camp for one week in each year. During this time they are supposed to conduct themselves in the same manner as the troops of the regular army would under similar circumstances. Whenever the State authorities request it, officers of the regular army are detailed to inspect these encampments and give instruction to the militia. These officers make minute reports of the results of their observations to the Adjutant-General of the U. S. Army. During the year ending Sept. 30, 1888, such encampments were held in fifteen States. Those desiring the most accurate and authentic information as to the present condition of the State-militia of these fifteen States, including among them the three largest States in the

Union, will find it in the annual reports of the adjutant-general to the secretary of war. "The regularly organized and uniformed active militia of the several States" in the year 1885 aggregated 84,739 men; in 1886 the number was 92,734; in 1887 it had increased to 100,837; and on July 2, 1888, it had an available force of 106,814 men. This is less than one fifth of one per cent. of our population, and less than the whole number of persons subject to military duty when required in the single city of New York.

(V. M. F.)
STATES' RIGHTS. In the general sense, this term, as applied in American political history, contains a reference to the relations subsisting between the United States and the respective States, but it has a special sense that describes a body of opinion that has exercised a large influence in moulding the institutions of this country. It is in this special sense that it is here considered. The States' rights doctrine is a theory of the construction of the Constitution of the United States, and not a general theory of government or communal society. It is to be regarded as an extreme expression of a tendency existing in all communities, definitely exhibited in those that have reached any considerable stage of organization, and especially in those that are composed of organized communities united to form a general or national community, as in the instances of imperial and federal systems of government. This tendency seeks to conserve the individualities of the organic units of the system as against an opposite tendency to blend the entire system into a single homogeneous and consolidated political society by the reduction of the functions of its integral parts, and the enhancement of the powers of the larger system. This tendency has a still broader interpretation, and is found in all organic systems conserving the individualities of their parts and subordinate organs.

The States' rights doctrine, as propounded within ten years after the adoption of the Constitution of the United States, and at a later period made the ground of an attempt on the part of a single State to nullify certain laws of the United States within its territories, and at a still later period the justification for an attempt on the part of several States to secede from the Union, denied to the United States the character of a national sovereign, affirmed that sovereignty remained in the States alone, to whom alone allegiance was due from the citizen; that the powers of the general government constituted an agency created by the States, federating together as independent sovereigns to attain certain definite ends of common interest to them by prescribed and limited means; that the sovereignty of the States remained undiminished by this delegation of powers, and that as such sovereigns they were without a superior to judge of the infractions of the Constitution, and thus entitled to judge, each for itself, of such infractions, and to seek a remedy for such wrongs either in nullifying the acts of Congress thus held to be in excess of its authority, or to secede from the Union and resume a state of entire sovereign independence.

The Constitution had conferred upon Congress the diplomatic and war powers of the government, the maritime police, the regulation of intercourse and the adjustment of differences between the States; certain special powers, including the fixing of commercial standards of value and quantity; general taxing powers, devoted to the payment of the debts, the common defence, and "general welfare" of the United States, and all other powers "necessary and proper" for carrying the same into execution. It was generally conceded that the powers of Congress were limited, but the nature and extent of that limitation were subjects of dispute between those en-

tertaining opposite theories of the proper construction of the Constitution.

An occasion arose, out of the complications incident to the unsettled political condition of France subsequent to the revolution that dethroned the ancient line of her monarchs, for the differences between the two schools of opinion to assume activity. Congress assumed a certain control over aliens and persons engaged in seditious practices within the States, that was claimed by the adherents of the States' rights doctrine to be in excess of its constitutional powers. On the one hand, sympathy with the popular aspirations that produced the French revolution and, on the other, apprehensions for the stability of government in the presence of such uncontrollable forces, gave color and warmth to the discussions that arose, and fitting conditions to produce extreme expressions of opinion on both sides of the question.

The contest was between a strict and a liberal construction of the Constitution. It was claimed by those adhering to a strict construction that the only powers that could be exercised by Congress were those which were specifically enumerated by the Constitution and such incidental powers as were necessary to the exercise of those specifically enumerated; and as authority over the citizens of the States, either permanent or temporary, was not among the enumerated powers, the attempt of Congress to interfere with the authority of the States over their own citizens, on the ground that they were aliens or seditions, was in excess of its constitutional authority. On the other hand, it was contended that the war powers and that of regulating intercourse with foreign nations and between the States justified such action, as essential to the common defence and general welfare. To this it was replied that Congress had no general authority to legislate for the promotion of the general welfare, but was only so far to provide for the general welfare as that was connected with the specific subjects committed to its authority, and that the war powers were inapplicable as the state of war did not then exist. As these differences were irreconcilable, it was necessary to consider whether any constitutional means existed for their adjustment. The national party contended that the national judiciary was the only recourse for their solution under the Constitution. This was denied by the States' rights party, who affirmed that the federal judiciary was the creature of the sovereign States, brought into existence by their act, and could not control its creator. The national party replied that the government of the United States was the supreme authority, superior to the States, within its sphere, and therefore the proper judge of the extent and limits of its authority. As every sovereign government is necessarily the judge of the extent of its authority, subject only to the right of revolution that is inherent in civil society, it was necessary to the position of the party of strict construction that the sovereign character should be denied to the government of the United States, and this position was taken. It was affirmed that the Constitution was the act of the State governments and not of the people of the United States as a whole, and as such was a mere league, of the infractions of which the parties to the compact were the sole judges as well as of the proper means of redress.

The gravity of an issue maintained not only by able and illustrious men but by organized States standing foremost in the rank of civilization, and that presented the alternative of placing the United States in the attitude of a national sovereign clothed with authority adequate to effectuate its purposes at home and to fulfil its engagements abroad, and with rank and dignity equal to that of any other nation, or to reduce it to the level of a diplomatic agency

depending for the effectiveness of its action upon ratification by a numerous body of independent States from whom its authority was derived, renders necessary a statement of the successive steps of this great controversy.

The war with Great Britain to maintain the declaration of independence made by the colonies exhibited the necessity of concerted action on their part and led to their confederation and representation in the Continental Congress. In this body each State, through its delegates, had an equal voice with each other in the adoption of public measures; but such measures lacked effectiveness through the frequent failures of the States to comply with the demands made upon them, and the inability of Congress to coerce compliance therewith. A profound conviction of the necessity of enlarging the powers of Congress arose throughout all parts of the country, that continued to gain strength after the conclusion of the war, and finally led to the calling of the convention of 1787, in which the present Constitution, apart from the amendments subsequently made, was passed for submission to the people of the United States.

The earliest plan submitted to the convention was that of Mr. Edmund Randolph, of Virginia. This plan proposed a national government, both in name and in substance. The essential feature was that it was to be derived directly from the people and was to act upon the people through laws judicially expounded and enforced by the national government. The powers of the government were respectively described as the national executive, the national legislature, and the national judiciary. The jurisdiction of the national government was to be confined to certain subjects, but in the exercise of its powers over these subjects it was to act as a sovereign government, superior to the governments of the States. The powers that were withheld from the general government were to be retained by the States, to be exercised by them as sovereign governing communities. According to this plan the political governments of the United States and of the respective States were to act independently of each other, but the national government, being supreme, its laws, properly enacted, would operate directly upon the people in such manner as to deny validity to any law of a State that infringed upon the national powers.

The Virginia plan was supported by the larger States, of which Virginia, Massachusetts, and Pennsylvania were the largest, both as to territory and population. The advantage of this plan to the large States was that, as the system was based upon popular majorities, they would have the greatest advantage from it, as a consequence of their being the most populous.

The smaller States, especially New Jersey, Delaware, and Maryland, were opposed to the Virginia plan, as giving a preponderating influence to the large States in the proposed government. They preferred the plan of the then existing confederacy, in which each State had an equal voice with every other in public affairs.

Mr. Patterson, of New Jersey, submitted a plan that received the support of the smaller States. This plan was based on the federal idea, according to which a federal government was to be instituted under the authority of the governments of the respective States, in which each State should have an equal voice with every other. According to this plan the federal government could only carry out its purposes through the aid of the State governments, having no efficient means of its own for the purpose. As the federal government could only act through the States, it was necessary to its existence that it should possess the means of coercing a State that

should fail to discharge its proper duties, and such a provision was contained in the plan.

A third plan was offered by Alexander Hamilton, of New York, which proposed a national government of unlimited powers, but which was not brought into discussion by the convention. South Carolina, throughout the discussions of the convention, adhered to the views of the larger States, and upheld the plan of a national government with limited powers.

Although a conflict of interests was recognized in the course of the discussion as existing between the Northern and Southern States, arising from the diversification of their respective institutions and industries, especially in view of the assumed necessity of perpetuating the institution of slavery in the last-named States, yet that consideration led only to modifications of details, and had no apparent effect upon the fundamental principle of the proposed government, the controlling influence in that respect arising from the political interests connected with the unequal distribution of population among the States.

These differences between the larger and the smaller States were adjusted, principally, in the constitution of the national legislature. The House of Representatives was to be chosen directly by the people of the States, who were to be represented in the ratio of population, so that a majority of the House would represent a majority of the people of the United States, without regard to State lines. By this disposition the people of the United States were unified as a whole for the purpose of making laws that should operate upon themselves, collectively and individually. Such governmental authority, so derived, where responsible to no higher authority, was necessarily sovereign, and where the objects for which it is created are national, as involving interests common to an entire independent community, such sovereignty is necessarily of the sovereign type.

The smaller States, while yielding thus far to this national scheme, insisted that the States in their political capacities should have a negative upon the popular action of the House of Representatives by giving to each State, independent of the extent of territory or population, an equal voice in the Senate, or what was then called the second branch of the national legislature. The larger States at length yielded to this demand, and it was concluded that each State should be represented by two senators, chosen by the legislatures of the respective States, constituting a senate which should have a negative upon all action of the popular branch, as well as upon certain functions of the executive that concerned treaties and appointments to office.

What was intended by the arrangement of the national legislature was that in all matters the action of the government of the United States should conform, on the one hand, to the will of the majority of the people of the United States as a whole, and, on the other hand, to the desires of a majority of the States as separate political bodies. Both of the schemes of government thus embodied in the Constitution contemplated a controlling influence of the general government over the States in all matters of national concern, the one that embodied the federal idea propounding direct coercion for that purpose, while the national plan secured the same end without coercion applied to the political government of the States by having direct authority over the people of the States by which they might be compelled to conform to the laws of the United States, and be prevented from conforming to the laws of the States that were infractions of the national right.

In the final framing of the Constitution the terms "national" and "federal" were both dropped without

eliciting any discussion tending to show that any important interests were regarded as in any way connected with their use or omission, and that the change was formal merely, such as might have been induced by the consideration that descriptive words were not necessary to define the nature of a government whose jurisdiction and powers had been fully set forth in its constitution.

It has been claimed in public discussion that the plan of a national government was rejected by the convention as inconsistent with the proper independence of the States, but this is obviously an error. Mr. Madison, whose report of the proceedings of the convention is accepted as standard authority, was in later years an advocate of the doctrine of States' rights, and it is not to be assumed that he either intentionally or accidentally suppressed so important a feature of the discussion. The discussions and action of the convention show that no other idea than that of a national government was entertained; that the subjection of the people of the States to the authority of the general government in all matters committed to that government was fully intended to be direct, so that the necessity of coercing the political governments of the States could never arise. Such a direct governmental relation between the general government and the people of the States constitutes the authority exercisable through it as sovereign, and that implies power to determine its own limits of authority, subject only to the ultimate right of popular revolution.

The differences between those who adhered to a strict and those who advocated a liberal construction of the Constitution were brought into discussion in the first Congress, in 1791, on the occasion of the incorporation by Congress of the Bank of the United States. Mr. Madison opposed the measure as beyond the competency of Congress. It was claimed by the advocates of the measure that such a financial institution was a necessary and proper means of enabling the government to exercise the functions conferred upon Congress by the Constitution. The position assumed by Mr. Madison was that a case of strict necessity must appear, to warrant the exercise of the power as within the class of incidental powers, and that it was not sufficient to justify its exercise that the facilities afforded by such an institution would be a convenience to the administration of the government. His view was that nothing was to be added by implication to the specific powers conferred upon Congress unless such implication arose out of actual necessity incident to the exercise of such specific powers, and that the fitness of the means proposed to attain its end was not the test of the propriety of the implication, but the circumstance that without such means the power could not be properly exercised. The charter of the bank was granted by Congress, and the institution was in operation many years before the discussion as to the validity of the authority under which its powers were exercised again attracted general attention.

In 1792 Mr. Madison opposed the granting by Congress of bounties to promote the cod fisheries upon the ground that it was not within the power of Congress. It had been contended that the authority of Congress to provide for the general welfare justified the exercise of the power claimed. Mr. Madison held that the authority of Congress to provide for the general welfare was limited to cases in which the general welfare was involved in some question relating to the specific subjects committed to the jurisdiction of that body. The discussion of this construction was renewed at a later day under circumstances giving it a wider and more interesting range, that will be mentioned.

The passage by Congress of the laws known as the Alien and Sedition laws was the first of a series of

important public events that brought into general discussion the nature and extent of the powers of Congress, and the means possessed by the States for confining the government of the United States within its legitimate sphere and restraining it from encroachments upon the reserved rights of the States, the succeeding events being the attempted nullification by South Carolina in 1832 of certain revenue laws, and the attempted secession from the Union of certain States in 1861.

The popular sympathy which in this country was ardently excited during the early stages of the French revolution in behalf of the condition and aspirations of our late ally gave place to apprehension for the safety of our own institutions and our amicable relations to foreign powers, as the instability of popular institutions in France was made apparent. Danger was apprehended from intrigues engaged in by resident aliens, and Congress authorized the President to remove from the United States aliens found here, upon such evidence of public danger arising from their presence as might be satisfactory to his own mind. At the same time a law was passed by Congress to punish sedition committed or attempted in the United States and the publication of statements and opinions hostile to the action of the government.

The warmth of discussion that followed the enactment of these laws was not alone due to the fact that to many it seemed that Congress had designedly overstepped the limits of its authority, and had entered upon a scheme of consolidating the national power by the destruction of the liberties of the States, but was due in part to the approaching political crisis that transferred public authority from the hands of the Federalists to those who, under the name of Republicans, were to control its destinies for many years, and also in part to the belief of many that the laws in question overthrew certain barriers indispensable for the protection of individual liberty, such as the right of trial by jury, the freedom of speech, of the press, and of religion.

The legislature of Kentucky in 1798 passed certain resolutions, of which the first, containing the statement of principles on which they were based, was as follows:

"1. *Resolved*, That the several States composing the United States of America are not united on the principle of unlimited submission to their general government; but that, by compact, under the style and title of a constitution for the United States, and of amendments thereto, they constituted a general government for special purposes, delegated to that government certain definite powers, reserving, each State to itself, the residuary mass of right to their own self-government; and that whensoever the general government assumes undelegated powers, its acts are unauthorized, void, and of no force; that to this compact each State acceded as a State, and is an integral party; that this government, created by this compact, was not the exclusive or final judge of the extent of the powers delegated to itself, since that would have made its discretion, and not the constitution, the measure of its powers; but that, as in all other cases of compact among parties, having no common judge, each party has an equal right to judge for itself as well of infractions as of the mode and manner of redress."

The remaining resolutions of the series declare certain acts of Congress, including the alien and sedition laws, to be in excess of the authority of Congress and void, as highly dangerous to the liberties of the States and the people, that immediate redress was demanded, and provide for the transmission of the resolutions to Congress and to the other States.

It is noticeable that these resolutions indicate no mode of redress, although claiming that each State had

the independent right to judge of the infractions and of the mode of redress, and propose no second course of action to be pursued by that State, either alone or concurrently with any other States. They were evidently intended as a declaration of principles for the consideration of Congress and of the people at the approaching general elections, looking to the repeal of the obnoxious laws and the overthrow of the party conducting the government.

The value of these resolutions as a statement of the doctrine of States' rights depends upon certain propositions advanced, and the reasons assigned for their verity. The leading statement is to the effect that the general government, "was not made the exclusive or final judge of the extent of the powers delegated to itself," and the reason assigned is that that would make its discretion the measure of its powers. Dependent upon this proposition, and necessarily true if the preceding one is established, is the proposition that each State has the right to judge for itself as well of infractions as of the mode and manner of redress.

The reason assigned for this statement is that it is a consequence common to all other cases of compacts among parties having no common judge. This compact is described as one made by the States for certain definite purposes. The denial of the existence of any common judge negatives the attribute of sovereignty in the United States, as all sovereign governments are superior to all the individuals and communities constituting them, and are judges of the limits of their powers. It is obvious, then, that the Constitution was regarded as a league among sovereign States creating certain governmental agencies, but parting with no part of their sovereignty. If such be the case, the principle that each party must judge for himself of the infractions and mode of redress would be applicable, assuming the non-existence of any competent judge among them.

The resolutions of the Kentucky legislature were sent to the several States then composing the Union, and replies were returned by several of these States, all of which, except that of Virginia, denied both the principles of construction applied by Kentucky to the Constitution and her deductions from those principles. Upon the receipt of these replies the legislature of Kentucky, in 1799, passed additional resolutions reiterating the positions assumed in the resolutions of the preceding year, and declaring "that the several States who formed that instrument, being sovereign and independent, have the unquestionable right to judge of its infractions; and that a nullification by those sovereignties of all unauthorized acts done under color of that instrument is the rightful remedy." At the conclusion of the resolutions they declare their object to be a solemn protest. As in the first series of resolutions, no purpose on the part of the State in view of the conditions stated is disclosed, and a disinclination to present an ultimatum is evinced by the emphatic statement of the object of the resolutions as that of a protest.

In view of the declination of a majority of the States of the Union to sanction the ground assumed by Kentucky, the only course open to that State was either to abandon its position or to claim that it was the right of individual States to seek such redress as to them respectively might seem appropriate, and this last of the alternatives was acted upon by the resolutions of 1799.

Following the resolutions of Kentucky, and in the same year, 1798, the legislature of Virginia passed resolutions upon the same subject, that were proposed by Mr. Madison. This action is in form and substance a protest addressed to the several States of the Union against the Alien and Sedition laws enacted by Congress. Adhesion to the Constitution and firm attachment to the Union are de-

clared. It is announced, "That this Assembly doth explicitly and peremptorily declare, that it views the powers of the federal government as resulting from the compact to which the States are parties, as limited by the plain sense and intention of the instrument constituting that compact, as no farther valid than they are authorized by the grants enumerated in that compact; and that in case of a deliberate, palpable, and dangerous exercise of other powers, not granted by the said compact, the States, who are parties thereto, have the right, and are in duty bound, to interpose, for arresting the progress of the evil, and for maintaining, within their respective limits, the authorities, rights, and liberties, appertaining to them." Regret is expressed that Congress appears disposed to assume unconstitutional powers tending to a consolidated government. Protest is made against the Alien and Sedition laws as the exercise of a power not delegated, that violates fundamental principles of liberty of conscience and the press. An appeal is made to the people of the States to "concur with this commonwealth in declaring, as it does hereby declare, that the acts aforesaid are unconstitutional; and that the necessary and proper measures will be taken by each for cooperating with this State, in maintaining unimpaired the authorities, rights, and liberties, reserved to the states respectively or to the people." Direction is given that copies be sent to the legislatures of the several States.

The Virginia resolutions of 1798 advance no opinion as to the existence of a constitutional remedy for the grievances complained of, indicate no line of action that ought to be pursued by the State beyond that of consultation with the sister States, and propose such consultation as the only object beyond that of entering a protest against the action of Congress. The case stated as imposing upon the States the duty of arresting the progress of the evil, and maintaining their liberties, is that of "a deliberate, palpable, and dangerous exercise of other powers not granted by the said compact." As a solemn public protest in a great national exigency, its words must be taken with that limitation suggested by the gravity of the occasion. The powers thus seized upon by Congress must be dangerous in their character, as where they violate fundamental principles of liberty, especially the liberty of conscience and the press, as charged against the action of Congress in another part of the instrument. Such powers must be obviously and unquestionably improper for Congress to assume, in order to satisfy the expression, "palpable." Finally, they must have been assumed for some purpose hostile to the objects of the Constitution, as for the purpose of establishing a consolidated government, as elsewhere charged in the same instrument, in order to satisfy the expression, "deliberate." If the case as stated had been actual, the right of revolution would have undoubtedly given the appropriate remedy, and the mode in which Virginia dealt with the question, if she so believed, must be regarded as moderate and conservative.

These resolutions were transmitted to the other States and replies were received from Delaware, Rhode Island, Massachusetts, New York, Connecticut, New Hampshire, and Vermont, all dissenting from the position of Virginia, and the majority of them claiming that the questions involved were proper for consideration only by the judiciary of the United States.

The character of the replies received and criticisms that had been made, unfavorable to the action of Virginia, induced the legislature of that State to reconsider the whole subject, and a report was made to that body by Mr. Madison reviewing the entire subject.

The report of Mr. Madison, made and adopted in the year 1800, sustains the propriety of the resolutions of 1798. It discusses the constitutionality of the Alien and Sedition laws, the character of those laws as violating fixed principles of government, and the propriety of the measures proposed by the resolutions of 1798.

The question of constitutionality is considered mainly under the clause of the Constitution that enables Congress to provide for the public defence and general welfare of the United States. He regards the authority to provide for the general welfare as limited to the specific objects enumerated as the powers of Congress. He contends that the only other construction possible would be that which should claim that anything that might tend to promote the welfare of the States as a whole might be done by Congress under it; that this would render nugatory the limitations intended to be imposed by the enumeration of specific powers. The report defends the resolutions from the charge of recommending improper measures, contending that all they intend is to bring about discussion and comparison of ideas among the States, whose action may be confined to representations to Congress to induce the repeal of these laws. It is claimed that the States have the right under the Constitution to confer together and concert action proper to be taken under the Constitution. The action of the legislature upon this report did not change the position of affairs assumed by the resolutions of 1798, either as to their form or effect.

The effect of the clause of the Constitution that enables Congress to provide for the general welfare has always had a conspicuous place in the discussions of the advocates of the different schools. This discussion has a prominent place in the report of Mr. Madison, as a vital feature of the controversy. If that clause was to be taken in its broadest sense, the power of Congress would seem to be unlimited, for it would, in that case, stand as a grant of general legislative power in the broadest terms. It was always conceded by those who put the most liberal construction on the Constitution that the powers of Congress were subject to limitation, and this excludes the clause under consideration from receiving the broadest construction of which it was capable if standing alone. The narrower doctrine was that Congress could only provide for the general welfare where matters were involved that were of common interest to the whole Union, which would place beyond the authority of Congress the attainment of objects of merely local interest. This construction Mr. Madison rejects and propounds the very stringent doctrine that Congress can only consider and provide for the general welfare as it regards the subjects placed in the enumeration of its powers. Intermediate between the larger construction, which Mr. Madison rejects, and the narrow one propounded by him is another, that does not appear to have received attention in the discussions at that time. In addition to the powers conferred upon Congress, certain other powers are inhibited to the States; if, then, a power thus inhibited to the States is of such a nature that its exercise is essential to the maintenance of government, the question whether the authority to provide for the general welfare did not authorize such power to be exercised by Congress, as a necessity of government, is one that would have to be considered before the rule of construction propounded by Mr. Madison could be accepted as a finality.

The agitation excited by the Alien and Sedition laws, that at one time threatened the stability of the Union, passed into the arena of general politics, and was one of the causes that placed Mr. Jefferson in the presidency, producing, through a change of

the persons administering the government, a change in its policy rather than of its nature. The prevailing tendency of popular excitements to find expression in the elective act, a striking feature and safeguard of our institutions, had its first distinct development in the instance of the Alien and Sedition laws, and is readily accounted for when it is observed that the road to the acquisition of public authority is made easy through popular ferment, and that the temptations to acquire such authority are greater than those that lead in the direction of dismembering and crippling the government.

In 1811 the question of the repeal of the charter of the United States Bank was agitated in Congress, and Mr. Clay opposed the power of Congress to incorporate a bank. He says: "What is the nature of this government? It is emphatically federal; vested with an aggregate of specified powers for governmental purposes, conceded by existing sovereignties, who have themselves retained what is not so conceded. It is said that there are cases in which it must act on implied powers. This is not controverted; but the implication must be necessary, and obviously flow from the enumerated powers with which it is allied. The power to charter companies is not specified in the grant, and, I contend, it is of a nature not transferable by mere implication. It is one of the most exalted attributes of sovereignty."

In the foregoing statement Mr. Clay should be regarded as conceding that sovereignty resides in the United States, as its powers are described as governmental, though limited, and emanating from a sovereign source; as the quality of that retained by the States is sovereign, that which they parted with, being intended for the same general uses, must have the same nature. He employs the term federal in the sense that has become general, as implying a governmental relation between communities exercising sovereign authority united through a common law for governmental purposes. Conceding the sovereignty of the United States, the right to judge of the limits of its powers, depending on the fact that such sovereignty is supreme, must be regarded as conceded, and hence Mr. Clay could not but regard the question of the sufficiency of the grounds of implying powers in the government of the United States as proper for decision by its judiciary.

In 1816 the Supreme Court of the United States, in the celebrated case of *Martin vs. Hunter*, was called upon to place a construction upon the Constitution as to the nature and limits of the powers of Congress. The judiciary act had provided for appeals from the highest courts of the States to the Supreme Court of the United States where questions of a federal nature were involved in their decisions.

This feature of the law was strenuously resisted as an assumption of authority not granted by the Constitution. Judge Story, delivering the opinion of the court, claimed that the Constitution proceeded from the people of the United States, and not from the States as political bodies, and that it was intended to limit the sovereignties of the States, and render the United States supreme, within its proper jurisdiction, over all State authority. His conclusion was, and such was the judgment of the court, that the grant of jurisdiction over cases arising under the Constitution, laws, and treaties of the United States is absolute, and, as such, extends to an appellate jurisdiction over the judgments of the State courts where questions of that nature arise.

The Supreme Court was again, in 1819, called upon to examine the fundamental nature of the powers exercised by Congress. The State of Maryland had assumed to impose a tax upon the operations of a branch of the Bank of the United States located in that State, and a controversy arose and was brought into that court involving the constitu-

tionality of the authority under which the bank exercised its powers, and of the act of Maryland taxing the institution. The court affirmed the authority of Congress to create the bank, and denied that claimed by Maryland. The position assumed by the court, as stated in the opinion of Chief Justice Marshall, is substantially as follows: The government of the United States was created by the people of the States as a sovereign government, though its jurisdiction was limited to certain specified subjects; that in relation to such subjects it was sovereign and superior to the States; that, in addition to the enumerated powers, it was intended to have all such powers as were proper in order to carry into execution the enumerated powers; that in the choice of means to carry out its powers it was not limited to such as were indispensably necessary for that purpose, but could use such as in its judgment were reasonably necessary and proper for that purpose; that it was the sole judge of the propriety of the means adopted so long as those means were suitable to the nature of the powers enumerated; that the power to borrow money and levy taxes implied the creation of banks to that end; that a law of the State of Maryland subjecting the powers granted to the bank to restrictions was inconsistent with the sovereign authority of Congress over the subject, and was therefore unconstitutional and void.

In 1828 Congress enacted a law imposing duties upon foreign importations, which was claimed to be intended for the protection of domestic manufactures, that gave rise to animated discussion both in Congress and in the States. In 1830 this discussion was maintained by Mr. Webster and Mr. Hayne, of South Carolina, in the celebrated debate upon the powers of the government. Mr. Webster's position was that, apart from the right of revolution, there was no power in any State to resist the authority of Congress under the Constitution. That the government of the United States was established by the people, and its responsibility is to the people alone. He admitted that New England had opposed the embargo law on the same grounds that South Carolina opposed the tariff, but had submitted to an unwelcome decision against her claims. He regards the Virginia resolutions as indefinite as to whether revolutionary or constitutional means of redress were intended. He says: "I hold it to be a popular government, erected by the people; those who administer it responsible to the people, and itself capable of being amended and modified just as the people may choose it should be. It is as popular, just as truly emanating from the people, as the State governments. It is created for one purpose, the State governments for another. It has its own powers, they have theirs. There is no more authority with them to arrest the operation of a law of the Congress than with Congress to arrest the operation of their laws."

Mr. Hayne in reply claimed that the government of the United States emanated from the sovereignties of the States as organized governments, and hence the agencies created could not control the power by which they were created. He regards the action of a State declaring the action of Congress as unconstitutional as a check which ought to be respected until appeal is made to the States collectively to ascertain their will in the matter, thus excluding the idea of coercion of a State on the part of Congress.

Mr. Webster, replying to Mr. Hayne, took the ground that, assuming the position that the Constitution emanated from the State governments, still the claim of South Carolina that a single State has an independent right of construing it cannot be maintained, as it could only be construed by the States acting together. And even in that case, where a means of deciding questions of construction was designated by the contracting parties, that means of

decision would be competent, and the only competent means. But he disputes this assumption, and contends that the people of the States, in their collective capacity as the people of the United States, made the Constitution.

In 1832 the first attempt was made to put into practical exercise the doctrine that the Constitution was a mere league or compact between sovereign states by which they parted with no part of their sovereign authority, but merely created certain governmental agencies for the common benefit, and subject to their control. In that year South Carolina adopted, in convention, an ordinance that declared unconstitutional and void the acts of Congress alleged to have been passed for the purpose of protecting domestic manufactures, and assumed to nullify those acts within the territories of that State, and threatened that if an attempt was made to apply force to the State she would withdraw from the Union and establish a separate government. The history of these transactions is given in another place under NULLIFICATION.

Assuming the premises claimed by South Carolina, that the Constitution created no sovereign authority that could be asserted as superior to the States, and that could act as the judge of the extent of the obligations assumed by the States, it would be difficult to deny the right of each State to act for itself in the manner propounded by the Kentucky resolutions, and practically acted upon by South Carolina in 1832.

The difficulty lies in maintaining the assumption that was the foundation of the deductions upon which that State sought to act. In addition to Congress and the judicial authority conferred upon the courts of the United States, a supreme arbitrator was created by the Constitution superior to the Constitution itself, and competent to bind the States by obligations that had not been assumed with the Constitution. The power of amendment over that instrument was placed in the hands of three-fourths of the States, and its exercise was to be binding upon the remaining States. This power of amendment was only limited in two respects, one of which related to control over the migration and importation of persons, and the other to the distribution of direct taxes. Beyond this limitation the power of amendment was unlimited. To affirm that a power by which a majority of a collective community of individuals or states may control the entire community, in an almost unrestricted manner, does not import sovereign authority, is the chief difficulty in the argument in favor of separate State liberty. A contract by which the majority of the contracting parties may change the terms of contract is certainly not an ordinary contract, and very clearly implies the existence of governmental authority that is inseparable from the idea of sovereignty. It is equally difficult for a State to say that it has only parted with so much of its liberty as is embodied in the terms of a certain instrument, where it has lodged in the hands of a power that may act independently of its authority ability to change those terms, and thus to subject it to new obligations. Nor is it easy to conceive by what reasoning it can be maintained that a supreme power that may mould the obligations of States can exist independently of the possession of power to judge of infractions of its requirements.

The attitude of South Carolina called forth the celebrated proclamation of Pres. Jackson that vindicated the national sovereignty of the United States, and the supremacy of her judiciary over all controversies arising out of the terms of the Constitution.

South Carolina at length yielded to a compromise act proposed by Mr. Clay by which the principle of national imposts for the protection of domestic manufactures was retained but certain economic advan-

tages were secured to South Carolina, according to her estimation, by the gradual reduction of the duties imposed to a minimum to be reached by 1842.

The next and final effort to practicalize the ideas of State liberty propounded by the States' rights doctrine was in 1860 and 1861, when South Carolina passed an ordinance for the secession of that State from the Union, and was followed by ten of the States that adhered to the system of legal slavery. The election of Mr. Lincoln to the presidency in 1860 was the transfer of public authority from the southern group of States to the section of the Union where slavery had become extinct, and was interpreted by the seceding States as an indication that that system could not look to indefinite continuance. The history of the events attending this effort to withdraw from the Union is given in another place under SECESSION. Armed resistance to the authority of the United States commenced with South Carolina, and a state of active hostilities ensued. The seceding States formed a confederated government and demanded that they should be treated as belligerents according to the laws of war, and this concession was made. The issue of the conflict was determined by military means, and the final surrender of the armies of the confederacy subjected the territory of these States to the consequences flowing from a state of war, according to which the supreme authority remained in the hands of the conqueror to be exercised according to his will. After a brief interregnum of military government, Congress provided for the readmission of the seceded States into the Union, establishing by its authority the popular basis upon which such reconstruction should take place. The people of the several States that had yielded to the military power of the United States accepted the conditions offered by Congress and formed State constitutions and governments, and were readmitted to representation in Congress. The history of these events is given under RECONSTRUCTION.

The whole force of the States' rights doctrine was centred in the question of the right of one or more States to secede from the Union where they had adjudged the action of Congress unconstitutional and detrimental to the liberties of the States. Nullification could only be regarded as a temporary remedy mainly intended, as claimed by Mr. Hayne, as a check to induce more full consideration before acting upon doubtful powers. The same argument that would sanction the right to nullify the laws of the United States within a State would justify that State to secede from the Union if the act of nullification proved insufficient as means of redress.

The entire question must then be regarded as involved in the related attitudes of the United States and the confederated States. That the States that remained in the Union after the act of secession held to the opinion that such right of secession did not exist is evidenced by the fact that they based the right to make war upon it. With the success of their arms restoration to the statehood implied acceptance of the principles of which the war was the expression. The doctrine of the war was the indissoluble union of the States, to form a sovereign national government, and the restoration of the States to full constitutional rights was the acceptance of a corresponding obligation upon the States thus restored. The consequence of this acceptance was that the judiciary of the Union, the people of the United States, and the States in the exercise of constitutional powers, were the ultimate recourse for the solution of all questions of right and duty on the part of States or individuals within the Union.

(A. J. W.)

STAUNTON, a city in Virginia, county seat of Augusta Co., is in the Shenandoah valley, on Lewis Creek, 60 miles N. of Lynchburg. It is on a branch

of the Baltimore and Ohio Railroad. It has a courthouse, 2 banks, 10 churches, a high school and excellent private schools, the State asylum for lunatics, and the State institution for the blind, deaf, and dumb. It contains also large iron-works, flour and planing mills. Three weekly newspapers are published here. The population in 1880 was 6664.

STEDMAN, EDMUND CLARENCE, poet and critic, was born at Hartford, Conn., Oct. 8, 1833. He entered Yale College in 1849, but left after some breach of discipline, though the degree of A. M. was conferred on him in 1871. While yet in college his poem *Westminster Abbey* won a prize, and appeared in the *Yale Literary Magazine* in 1851. After editing the *Norwich Tribune*, 1852-53, and the *Winsted Herald*, 1854-56, he removed to New York, and wrote for the magazines and newspapers. His first notable success was gained in 1859, through the appearance in the *New York Tribune* of *The Diamond Wedding* and several other pieces in verse. These, with others, were gathered in his *Poems, Lyric and Idyllic* (1860). *The Prince's Ball*, reprinted from *Vanity Fair* later in the same year, commemorated the visit of the Prince of Wales to the United States. In 1861-63 he was war correspondent of the *World*, writing from headquarters of the Army of the Potomac, and from Washington. Returning to New York in 1864 he gave up journalism for the stock exchange, but continued to write verse. His *Alice of Monmouth* appeared, 1864; *The Blameless Prince, and Other Poems*, 1869; *Rip Van Winkle*, 1870; and subsequent volumes, 1877 and 1879. His *Poetical Works* were collected in 1873, and in a *Household Edition* in 1884. Some of his poems were written for special occasions. *Gettysburg* was read before the Army of the Potomac at Cleveland in 1871, an *Ode* at Dartmouth College in 1873, *The Monument of Greeley* at the dedication in Greenwood Cemetery in 1876, *The Death of Bryant* before the Century Club in 1878, *Meridian* at the 25th anniversary of his Yale class in 1878, and *Cordis Concordia* before the Concord School of Philosophy in 1881. Of late years Mr. Stedman has turned his attention to criticism, and done some of the best-considered critical writing that has been produced in America. Articles in *Scribner's*, afterward *The Century*, were the basis of his *Victorian Poets* (1875), of which the 13th edition (1887) is brought down to date. His *Poets of America* (1886) is a similar work, deserving even greater praise, on account of his steadfast maintenance of the true judicial tone. Mr. Stedman edited Austin Dobson's *Poems* (1880), and, with T. B. Aldrich, *Cameos from Landor* (1874). He is now, with Miss Ellen M. Hutchinson, editing a *Library of American Literature*, being selections from all home writers of any note from the earliest colonial times: this is to fill ten large volumes.

STEEDMAN, CHARLES, rear-admiral, was born, Sept. 24, 1811, at Charleston, S. C. In 1828 he entered the navy as midshipman; in 1834 became passed midshipman, cruising in the frigates *Constitution* and *United States*. In 1841 he received his promotion as lieutenant, and in 1846-47 served in the Mexican war in the sloop *St. Mary's*. When Vera Cruz was bombarded he had command of the siege-guns in the naval battery on shore, and, besides other operations on the coast, took part in the boat-expedition that effected the capture of Tampico. In September, 1855, he was promoted to commander, and as such was in charge of the brig *Dolphin* in the Paraguay expedition. When his native State seceded in 1861 he resisted the efforts of family and friends and remained loyal to the Union, to which he rendered efficient service. His first service in the cause was to convey Gen. Ben. F. Butler, with the Eighth Massachusetts Regiment, from Havre de Grace to Annapolis, Md., in the railroad ferry-steamer *Maryland*, the command of which he received in an-

swer to his request for duty. Thereafter he served under Admiral Foote in the organization of the naval force that manned the gun-boats on the Mississippi. In September, 1861, he co-operated, as commander of the steamer *Bienville*, in the capture of Port Royal, and in the operations on the coast of Florida and Georgia. In September, 1862, he was made captain and, in charge of the Powhattan, took part in the blockade of Charleston, in various engagements there, and in the capture of Fort McAllister, on the Ogeechee, which led to the evacuation of Savannah. After towing the captured ram *Atlanta* to Philadelphia, he went in command of the *Ticonderoga* to the coast of Brazil in pursuit of the Confederate cruiser *Florida*. In this vessel he continued to serve during the remainder of the war, taking part in several operations, and finally went on a cruise in the Mediterranean, whence he returned in 1867, in command of the frigate *Colorado*. Meantime, in July, 1866, he had been appointed commodore. From 1869 to 1872 he was in charge of the Boston navy-yard. In May, 1871, he was advanced to rear-admiral, and finally retired from the service, Sept. 24, 1873.

STEEDMAN, JAMES BARRITT, general, was born, July 30, 1818, in Northumberland Co., Pa. He was emphatically a man of energy and action, and before the war had been a contractor on the Wabash and Erie Canal, a member of the legislature of Ohio, the organizer of a party to cross the plains to California in search of gold (from which he returned next year), a member of the Ohio board of public works, the public printer at Washington during Buchanan's administration, and a delegate to the convention at Charleston in 1860, where he advocated the nomination of Stephen A. Douglas. On the outbreak of the war he became colonel of the Fourth Ohio Regiment, and was sent to Western Virginia. Here he was engaged in the battle of Philippi; thereafter he joined Gen. Buell in Kentucky, and in July, 1862, was promoted to brigadier-general. In this capacity he rendered efficient service at the battle of Perryville, arriving on the field just in time to drive back the enemy, who had broken the Union line. In July, 1863, he was appointed to the command of the First division of the reserve corps of the Army of the Cumberland, and at the battle of Chickamanga re-enforced Gen. Thomas at a moment of great emergency. For this he has been given the credit of saving the day, though the honor of suggesting the movement is usually assigned to Gen. G. Grauger. His services here earned him the rank of major-general (April 24, 1864). He afterward served in Sherman's Atlanta campaign, everywhere showing zeal and courage. When Thomas left the expedition to return to Nashville, Gen. Steedman joined him, and performed efficient service. In 1866, after serving as provisional governor of Georgia, he resigned, and received the appointment of collector of internal revenue at New Orleans. Here his want of familiarity with business involved him in financial difficulties, and he returned to Ohio. In 1879 he was elected to the State senate, but on a second canvass was defeated. A few months before his death he was made chief of police of Toledo, where he was ostensible owner and editor of the *Weekly Ohio Democrat*. He died at Toledo, Oct. 18, 1883.

STEEL. Every description of iron ore will give cast iron and wrought iron, the properties of the product obtained depending upon the ore and the method used; but in all cases the terms "cast iron" and "wrought iron" will be applied to the extreme results and all intermediate products which cannot be classed with cast iron on the one hand, or the wrought iron on the other, may be called steel. It forms the link between cast and wrought iron, and unites the properties of both, the distinguishing

characteristic being that it may be hardened or softened at will by rapid or slow cooling. When exposed to heat it takes on in succession the following colors:

1. A faint yellow, which shows the proper temperature for lancets and other fine cutters that require the finest edge, with but little strength of metal.
2. A pale straw-yellow, the temperature for razors and surgical instruments.
3. Full yellow, for pen-knives, with increased toughness.
4. Brown, with purple spots, for axes and carpenters' tools.
5. Bright blue, for swords and watch-springs.
6. Full blue, for fine saws and daggers.
7. Dark blue, for large saws, or instruments that may be sharpened with a file.

Proportions of Carbon in Steel and Iron.

	Percent. of carbon.
Pure wrought iron.....	0.000
Soft steel.....	0.075
Mild steel.....	0.08 to 0.20
Hard steel.....	0.20 to 0.40
Tool steel.....	0.40 to 0.80
Malleable cast iron.....	0.88 to 1.53
Draw-plate steel.....	3.30
Cast iron.....	4 to 5

Steel, then, may be produced by any process which adds carbon to wrought iron or reduces it in cast iron.

Puddled steel is made in the puddling furnace. In changing into wrought iron in the furnace the metal passes through the state of steel, or becomes steel before it becomes wrought iron; so to get steel the usual puddling process is stopped at such a stage in the working as will give steel.

A very old process is the process by cementation or heating bars of iron embedded in charcoal for from six to ten days. The iron is in the form of straight bars about 3 inches wide and $\frac{1}{4}$ inch thick. Fine charcoal in cubes of $\frac{1}{4}$ to $\frac{1}{2}$ inch edge is placed in the bottom of the converting pot or chest, which is made of fire-brick or fire-stone; on this the bars are laid close together, and then another layer of charcoal about $\frac{1}{4}$ inch thick and a layer of bars, and so on till the chest is full, when a thick layer of charcoal is placed on the top and a compact, air-tight covering of grinder's waste or clay is pasted over the top. The chest is then placed in a furnace and a temperature of glowing redness kept up during periods varying with the quality of steel desired. Spring steel requires seven days; shear steel, eight days; and steel for welding, from nine to ten days. When taken out the fractured bar has no longer the bluish tint of malleable iron, but has acquired a reddish-white color and a scaly, crystalline texture. A remarkable characteristic of the carbonized bars is the blistering of the surfaces, from which it gets the name of "blister steel." When the blisters are small in size and are regularly distributed the steel is of good quality; when they are large and follow certain lines it indicates a want of homogeneity in the iron used. The average increase of weight experienced by the iron during conversion is from $\frac{1}{4}$ to $\frac{1}{2}$ per cent., and the amount of coal consumed is from 75 to 90 per cent. of the weight of the steel produced. Blister steel is used for facing hammers and sledges; when drawn out at a low heat it is used for spring steel, but the texture is not sufficiently uniform for general purposes, and drawing out the bars necessarily entails a loss of carbon and, in consequence, a loss of hardness.

The proper uniformity of structure may be obtained, however, by breaking up the steel made by cementation and fusing the pieces in air-tight crucibles, from which the steel is poured into moulds, or when a large casting is to be made a number of

crucibles are emptied into one large ladle. Krupp casts ingots weighing 20 tons, using 70-lb. crucibles, the mixture in the crucibles being puddled steel, wrought iron, and carbonaceous matter. The melting hole or furnace is a rectangular cavity about 2 feet square and 3 feet deep, lined with fire-brick, with the top on a level with the floor, and the grate bars and ash-pit readily accessible from below, with a square fire-tile for a cover. A short rectangular flue is below, communicating with the chimney. A number of such furnaces are arranged in parallel lines, with spaces between for moulds. The crucibles are made of a mixture of refractory clay and coke dust and are 16 to 18 inches high, and 6 to 7 inches in diameter. Two crucibles are usually put in a furnace with charges from 35 to 80 lbs. The crucible is annealed by heating to redness in an open fire, and is then put in the furnace, and the charge of blister steel or such mixture as may be desired, the cover is put on, and the full heat of the furnace kept up for four or five hours. To tell when the charge has been thoroughly fused the cover is taken off and the inside felt with a rod, and when fused it is left at rest for a time depending upon the desired temper. The slag is skimmed from the surface and the crucible lifted out by a pair of tongs and the contents poured into a cast-iron mould, the mouth of the mould when full being covered by a shovelful of sand or a plate of sheet iron. The fuel consumed is from three to four times the weight of metal produced. The fractured surfaces of the softer *crucible steel* ingots are bright and finely granular; the harder varieties exhibit distinct crystalline plates arranged in parallel bands. The ingots are nearly always unsond, and the vesicular cavities can only be removed by reheating and hammering at a low temperature.

Maslet was granted a patent in England, in 1800, for a process of manufacturing cast steel by firing malleable iron in crucibles with carbonaceous matter, and in 1839 a patent was granted William Vickers for the production of cast steel by melting 100 parts of iron borings with 3 parts of black oxide of manganese and 3 parts of ground charcoal.

Case-hardening is a rapid process of cementation by which the surface of wrought iron is converted into steel. The piece to be case-hardened is embedded in animal charcoal in a chest, and this is placed for a short time in a smith's forge or a furnace, and when taken from the fire the object is hardened by heating it to redness and plunging it while still red hot into cold water. Small articles may be so hardened externally as to resist a file, by sprinkling a little ferrocyanide of potassium on the surfaces while red hot. As soon as the powder has disappeared the article is quenched in cold water.

Instead of producing the steel by causing a certain amount of carbon to combine with wrought iron, carbon may be taken from the cast iron. The first way that this was done was in the open hearth, though improved methods have about done away with this process; but the term open-hearth steel is still used to distinguish the product of the Siemens-Martin furnace. The hearth is filled with burning charcoal and a number of plates or slabs of lamellar cast iron are melted in the blast of the tuyere, a quantity of rich slag and iron scale being added to assist in the oxidation of the carbon. About thirty cubic feet of charcoal are used per cwt. of steel produced.

Puddled steel was produced in Carinthia as early as 1835, and by 1845 it had become a staple product. There is but little difference between puddling for steel and puddling for iron (see Iron), except that in the latter case the decarbonization is more thoroughly effected. The crude irons that are best for this purpose are those that are rich in carbon and

manganese, so that spiegeleisens mixed with mottled pigs are very good. The furnace bed is usually smaller than in the iron furnace, to command a higher temperature with the same-sized chimney and fire-place. The charge is so distributed in small fragments that it will all become fused about the same time. The charge is from 3 to 3½ cwt. This must be perfectly fused and covered with a stratum of liquid slag to regulate the oxidation of the carbon. The melting down, stirring, or rabbling is done at a higher temperature than with the iron puddling and occupies usually from 40 to 50 minutes; the steel balls are formed, however, at a lower temperature than those of iron, and at this stage the furnace should be filled with smoke to produce a neutral or non-oxidizing atmosphere by closing the damper. The appearance of the particles of the metal brought above the slag by the stirring tells the progress of the operation and the nature of the product. When brightly granular it indicates satisfactory progress and the production of steel of fine grain and good quality. When flaky and coarsely granular the steel is likely to be coarse in texture and imperfectly refined. The shingling of the balls is conducted at a lower temperature than with iron, and when not taken immediately to the hammer are rolled in slag to prevent oxidation. The time required under ordinary circumstances to work off a heat of iron and steel will be as follows:

	Iron.	Steel.
Melting down.....	30 to 40 minutes.	40 to 50 minutes.
Stirring	30 " 35 "	45 " 50 "
Boiling and fusing... 25 " 30 "	" "	20 " 25 "
Balling.....	10 "	10 "
Total.....	95 to 115	115 to 135

From 1800 to 2000 lbs. of shingled steel balls can be obtained from one furnace in 12 hours, in from six to seven charges. In puddling steel, from 30 to 35 per cent. more coal will be used than the weight of steel produced. The puddled balls when under the hammer emit a blue flame, due to the combustion of carbonic oxide. To draw into bars, the blooms must be reheated before being put under the hammer, or into the rolls.

Numerous attempts have been made to produce steel cheaply, and to Sir Henry Bessemer is due the credit of discovering a quick way to convert pig-iron into steel. This process was first made public by him at the Cheltenham meeting of the British Association in 1856. This is a very simple process, and consists in charging a quantity of about five tons of melted pig-iron into a furnace shaped like a gingerale bottle mounted on trunnions, having an open top, and a bottom perforated by a number of holes, through which air is forced in small jets by a powerful blowing-engine. The blast of air, forced up through the molten metal, effects the rapid oxidation and consequent combustion of the carbon, silicon, and other foreign substances. A very high temperature is produced, sufficient to keep liquid the resulting decarbonized iron, and if the blast be kept up after the carbon is all burnt out the iron itself will be burnt; so, before this point is reached, the blast is stopped, and a charge of spiegeleisen containing the necessary amount of carbon is introduced. Pig-iron of exceptional purity must be used, and it should be free from sulphur, phosphorus, and copper. The spiegeleisen is an alloy of carburized iron and manganese. This, containing about 5 per cent. of carbon and from 10 to 25 per cent. of manganese, is put in to replace the carbon that has been burnt away, and sufficient to give the required proportion of carbon in the finished metal. The converter consists of a shell of wrought iron, suspended by means of a wrought-iron hoop, B, carrying trunnions, C, supported by cast-iron stand-

ards, D, one solid carrying a pinion, E, gearing into a rack, F, worked by a small engine, for turning the converter to a horizontal position. The other trunnion is hollow, and forms a passage for the blast. The lining, A, is the most refractory material that can

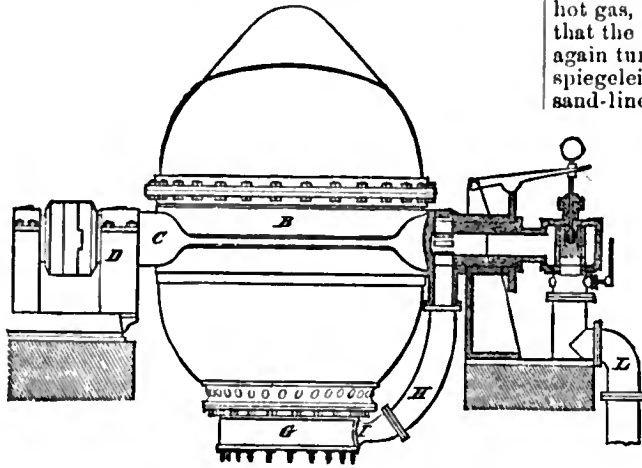

FIG. 1.—Bessemer Converter.

be obtained. It is made from fine-grain silicious sandstone known as gannister. It is finely ground, and then sometimes mixed with powdered fire-brick, then incorporated with a small quantity of water, and then lightly rammed between the outside casing of wrought-iron and an inside wooden core, which is afterward withdrawn. The bottom consists of a plug of the same refractory material, with a number of holes or tuyeres, T, T, opening below into an iron box, G, which communicates with the hollow trunnion by means of a pipe, H, so that air can be blown up through the molten mass in the converter. The operation is as follows :

The charge is melted in a cupola or run direct from the blast furnace, and the converter, which has been previously heated to redness by filling it with ignited coal, is reversed to remove any unconsumed

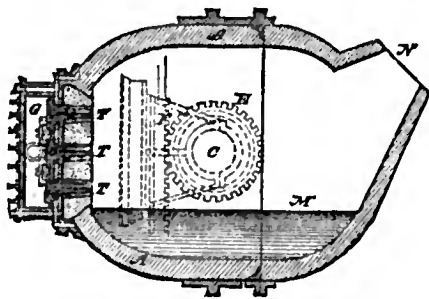

FIG. 2.—Bessemer Converter.

fuel, and then brought to a horizontal position (Fig. 2) to receive the charge of molten metal, which is run in through an iron gutter lined with sand. The converter is then slowly turned back into the vertical position, the blast being at the same time turned on. The flame which first issues is yellowish red. Graphitic carbon passes into the combined state; the silicon becomes oxidized, and silicates of iron and manganese are formed. This first stage, which takes about five minutes, is followed by a period of violent boiling, during which the combined carbon is rapidly oxidized by the blast. Carbonic oxide being evolved in large quantities, the flame increases in brilliancy, and showers of sparks and fragments of burning iron are thrown off. This lasts for about

seven minutes, when the intensity of the action begins to diminish. Fewer sparks are given off and the flame acquires a bluish-violet tint, marking the commencement of the last stage. As soon as the carbon is all consumed the flame ceases, being immediately succeeded, however, by a flame of white-hot gas, principally nitrogen. As soon as it is seen that the carbon is about burnt out, the converter is again turned back to a horizontal position and the spiegeleisen run in from a furnace by means of a sand-lined gutter. When very mild metal is needed, the tempering is done with ferro-manganese, made hot and shovelled into the ladle while pouring. The steel is decanted from the converter by turning the top down and letting it run out into cast-iron moulds open at both ends, and a little larger at one end than the other, so that the ingots can be easily turned from them when cool.

In the Bessemer process, as described above, it is necessary to employ pig-iron containing a very minute quantity of phosphorus, as but little of that element is eliminated during conversion. This means very costly and scarcer ores; but steel can now be made by the *basic* method from iron smelted from cheap ores, the pig to be sufficiently free from sulphur, not to

contain more than one per cent. of silicon, while the phosphorus should not be less than 2 to 2½ per cent. This process is called the *basic* process, to distinguish it from the *acid* process of Bessemer. The terms refer to the lining of the converter, acid-signifying quartz or gannister, and basic lime and magnesia as existing in calcined dolomite. The chemical fact involved is that the retention of phosphorus in the blown metal is materially influenced by the character of the slag, which is a silicate of iron and manganese, and if reduced to a lower silicate by the addition of other bases phosphorus can be removed by oxidation. Lime is used for dephosphorizing after the carbon of the metal has been oxidized. When the converter is ready for charging it is made hot by a coke fire, and a quantity of quick-lime, from one-seventh to one-fifth of the weight of the charge of metal, is introduced, made as hot as possible. The metal is then charged in the usual way and the blowing conducted as already described. In about ten minutes the carbon is burnt out and the dephosphorizing period commences. This is marked by a great increase in the temperature of the bath and a thickening of the converter smoke from the burning of the iron, the flame showing peculiar bright patches which are not seen in the old process. The length of the after-blow is regulated by breaking small test-ingots, which should show a close, silky fracture, entirely free from bright crystalline particles. When the desired metal has been obtained, the converter is tipped to run off the slag, after which the metal is brought to the final temper by the addition of the proper amount of spiegel and ferro-manganese, the former in the converter and the latter in the ladle after pouring. The slag must be removed, as a portion of the phosphorus may be reabsorbed if left in contact with the metal.

There are diverse opinions as to the relative values of steel made by the acid and basic processes. The latter, utilizing the cheap ores, is remarkable for its purity and mildness, and this is likely to bring about its use on a large scale in the construction of boilers, ships, bridges, and other structures requiring toughness. The basic process is used both with the Bessemer converter and the Siemens-Martin furnace or open-hearth process.

The grandest application of the Bessemer process

is the manufacture of steel rails, though, strange to say, when granted the patent for this process he was denied the right to manufacture rails.

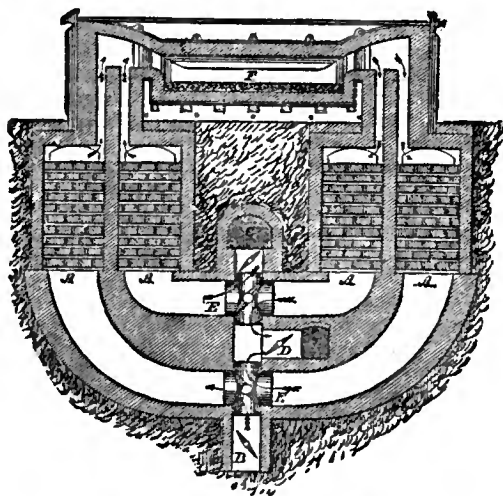

FIG. 3.—Open hearth Furnace.

The *Uchatius* process of making steel is to effect the partial decarburization of pig-iron by fusion in contact with ferric oxide, or some other substance

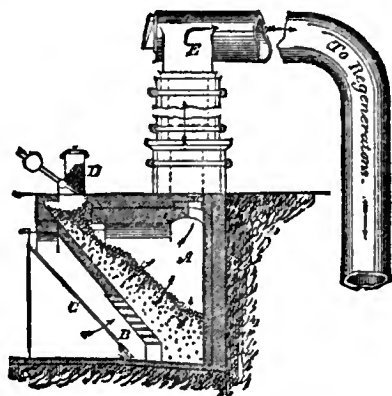

FIG. 4.—Open-hearth Furnace.

capable of yielding oxygen. The pig-iron is granulated by running the fused metal into water, and mixing the granulated metal with about 20 per cent. of roasted spathic ore and 4 per cent. of fire-clay. The mixture is then melted in clay crucibles in an ordinary cast-steel furnace.

Another method of obtaining steel is by the fusion of a mixture of cast iron and wrought, the carbon distributing itself between the two and so forming steel.

The production in a reverberatory furnace of cast-steel, by the solution of malleable scrap in molten pig-iron, has been brought to a high state of perfection by the use of the Siemens regenerative gas furnace. This is heated by gas produced in the furnace itself.

The greater part of the heat of the gases coming from the furnaces is stored in *regenerators*, and this heat is used in keeping up the temperature of the furnace. The regenerators are chambers of refractory brick placed in horizontal layers, with spaces between them

to offer a large surface of contact for the gases. There are four of these chambers, two communicating with one, and two with the other, end of the furnace. The mixture of combustible gases and air reaches the furnace F after having passed through two of the regenerators, A, A, at one end, and passing through the furnace pass out through the two regenerators A, A, at the other end, as shown by the arrows in Fig. 3. The bricks of the regenerators store up the greater part of the heat of the gases that have left the furnace, and the products of combustion pass off by the chimney D. Now, by aid of the valves, the course of the gases is reversed, and the gases pass into the furnace through the regenerators that have just been heated, and out by the ones that have been furnishing heat. In this way the gases, slowly passing through a honey-comb of hot bricks, are intensely heated, and reach the hearth at a temperature nearly that of the furnace itself, so that the combustion develops an intense heat. The temperature is raised at each reversal of the valve E, the volume of the gases being regulated by the register C, the volume of air being controlled by B, and the draught by the chimney damper D. The gas producer (Fig. 4) consists of a chamber, A, of fire-brick. D is a hopper to regulate the supply of fuel, and C a pipe for introducing water to the bottom of the furnace. The pipe E conducts the gases to the furnace.

The furnace (Figs. 5 and 6) is reverberatory, with a single door, A, on one side, and on the opposite side a tapping hole, B. The gases from the regenerators, and the air to burn them, arrive and depart at the ends C, C and E, E. A bed of iron, cooled by a current of air from below, holds the lining of sand or gannister. The furnace is heated to a white heat by the hot gas, and receives then a charge of hot cast iron, and when this is properly melted soft iron, heated to a bright red, is introduced. These additions are made about every half-hour, and the whole is then vigorously stirred. When by tests the metal is found to be sufficiently refined, red-hot cast-iron is added. Tests are made, and cast-iron added till the proper carburization is arrived at, and the product is then tapped. The operation takes from nine to eleven hours with 5 to 6-ton charges. From 13 to 14 cwt. of coal is consumed per ton of ingots.

A modification of this process is seen in the Perrot rotating furnace, which is made with an inclined bed, as shown, and when rotated the molten metal flows from side to side, the bed standing under the arch of the reverberatory furnace, and over the regenerators. From two to four revolutions are made per minute, and as the pieces of the charge are con-

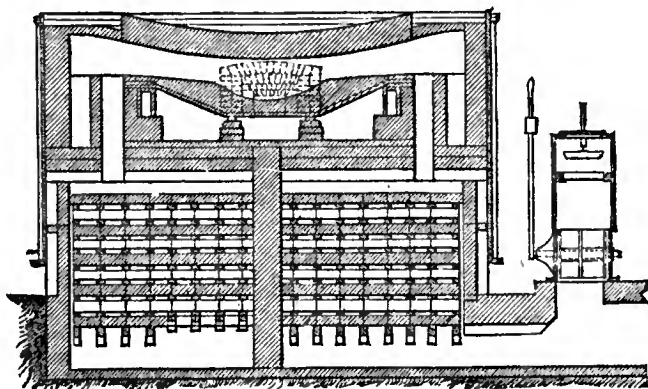

FIG. 5.—Open hearth Furnace.

tinually changing from exposure to the flame to full immersion the fusion is very rapid, and the bottom, being exposed to the flames at short intervals, is

kept at a high temperature, so that there is no sticking of the charge to the bottom. These furnaces are extensively used in this country.

The steel used in the vessels now constructing for the U. S. navy is made in ordinary Siemens-Martin furnaces, Bessemer steel not as yet being used for this purpose, though basic steel is used extensively for ship rivets.

The basic method of dephosphorization is now being extensively used in the manufacture of steel in

Allen, of the Bessemer Works, Sheffield. He inserts a two-bladed propeller on the end of a vertical shaft into the ladle just before casting, and stirs the metal, liberating the gases and thoroughly incorporating all parts.

This country can now produce within its borders all the iron ore needed in every branch of its iron and steel industries, including the finer grades of crucible steel. We have ores in great abundance for the manufacture of acid Bessemer steel, but they are confined to comparatively limited areas. We have beds of ore for the manufacture of spiegeleisen and ferro-manganese, that would place our country on a self-sustaining basis, in case the foreign supply should be interrupted. But the spiegeleisen is not a large item in the manufacture of steel, and it is more economical now to import it. Great Britain is entirely without manganese iron ore deposits. The first steel of any kind produced in the South was made with the Henderson Steel and Manufacturing Company's open hearth furnace at Birmingham, Ala., Feb. 27, 1888.

In 1887 the United States produced 47,598 tons of spiegeleisen. Ore of a character suitable for the manufacture of spiegeleisen was discovered in Independence Co., Ark., and railroad connections with this region were completed in 1887, though all the ore shipped in that year, 926 tons, was sent to the Edgar Thompson furnaces at Braddock, Pa. Our production of spiegeleisen since 1875 is as follows:

Years.	Tons.	Years.	Tons.
1875.....	7,852	1882.....	21,063
1876.....	6,616	1883.....	24,574
1877.....	8,845	1884.....	33,893
1878.....	10,674	1885.....	31,671
1879.....	13,931	1886.....	47,982
1880.....	19,603	1887.....	47,598
1881.....	21,086		

the open-hearth furnace, a bed of shrunk dolomite or magnesia being substituted for that of gannister used in the Siemens process.

In casting steel in large masses, whether from crucibles, Bessemer converters, or open-hearth furnaces, it is often difficult to obtain sound ingots, especially when the steel is a mild one, the upper part usually being honey-combed to a greater or less degree—due probably to the escape of carbonic oxide or hydrogen gas. The necessary consolidation of ingots intended for rolling or forging is effected by subjecting the metal while in the mould to hydrostatic or gaseous pressure until it sets, preventing in this way the escape of gas, or else giving the gas a chance to escape by stirring or pouring from one ladle to another. Sir Joseph Whitworth applies

The iron and steel production of the United States has been subject to periods of depression, and at times it has been necessary for the manufacturers to regulate the production to bring about a healthy state of trade; for in times of booms the manufacture is apt to be carried to such an extent as to exceed the demand. The year 1887 was the most active year in the history of the American steel and iron trade, the following table showing the production in that year as compared with 1885 and 1886.

Products.	Tons of 2000 lbs.		
	1885.	1886.	1887.
Pig iron.....	4,259,869	6,635,328	7,187,206
Bessemer steel ingots....	1,701,762	2,541,493	3,288,357
Bessemer steel rails.....	1,074,607	1,763,667	2,354,132
Open hearth steel ingots..	149,381	245,250	360,717
Open hearth steel rails....	4,793	5,255	19,203
Crucible steel ingots.....	64,511	80,009	84,421
Rolled iron except rails...	1,789,711	2,259,943	2,565,438
Iron rails.....	14,815	23,679	23,662
Kegs cut nails (100 lbs)...	6,696,815	8,160,973	6,908,870
Pig, scrap, and ore blooms.	41,700	41,909	43,306

This table shows a wonderful progress, such as has never been witnessed in other great industries of this or other countries. In the two years from 1885 to 1887 we increased our production of pig iron 58 per cent, of Bessemer steel ingots 93 per cent., of Bessemer steel rails 119 per cent., of open hearth steel ingots 141 per cent., and of rolled iron 43 per cent. In these two years over 21,000 miles of new

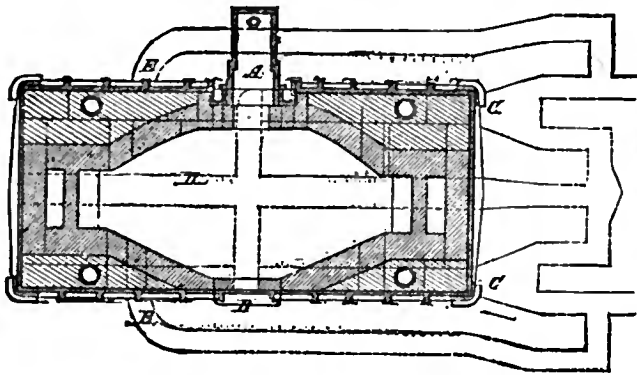

Fig. 6.—Open-hearth Furnace.

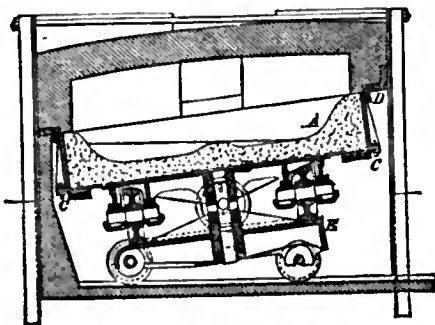

Fig. 7.—Pernot Rotary Hearth.

the first method on a large scale; his fluid compressed steel being subjected to a pressure, while melted, of from 6 to 20 tons per square inch. The density of metal is increased about 3/4 per cent. over that cast in the open moulds. At Pittsburg steam has been used, and Krupp uses liquid carbonic acid to supply the pressure. In the former the mould is covered by a closed lid wedged down to form a steam-tight joint, and this communicates by a flexible pipe with a steam-drum supplying steam at a pressure of from 80 to 150 lbs. per square inch, which is allowed to act till the metal has set.

The most noticeable method of producing homogeneity in molten metal by agitation is that of Mr.

railroad were constructed, for 1886, 8999 miles, and for 1877, 12,500 miles. These new roads demanded steel rails, tools, locomotives, bridges, and cars, all using steel, and the general prosperity of the country created an extensive demand in manufacturing, agricultural, and other enterprises requiring the use of iron and steel. Old roads, finding their trade heavier, put in steel rails and built heavier bridges. Congress appropriated large sums of money for new vessels, armor, and guns, all requiring steel of the very best quality in vast quantities. The population increased by about a million, and these required steel for domestic and other purposes. Finally, iron and steel were much used in the building of new iron and steel works in the South. Notwithstanding the great demand, the prices were kept within reasonable limits. The year 1888 started badly on account of freight-rate wars, strikes, the blizzard, and the uncertainty as to the tariff. These affected the earnings of the roads, but the consumption of steel for miscellaneous purposes, and the manufacture of steel rails for renewals, extensions, and new roads, was large. The bridge-works, the foundries, the machine shops, the car builders, the car-wheel manufacturers, and the locomotive builders are still very busy.

Imports of Iron and Steel.

Commodities.	Tons of 2000 lbs.			
	1884.	1885.	1886.	1887.
Pig iron.....	206,381	164,349	405,190	523,675
Scrap iron.....	50,192	15,480	97,675	351,026
Scrap steel.....	8,388	2,196	11,351	29,716
Bar iron.....	40,998	35,251	32,647	40,545
Iron rails.....	91	57	7	270
Steel rails.....	3,074	2,395	45,571	154,099
Cotton ties.....	17,518	20,576	11,561	24,276
Floor, banl, and scroll iron.....	332	103	128	25
Steel hoops, sheets and plates.....	24,610	33,718	167,257	347,818
Sheet, plate and lagging iron.....	7,863	6,200	6,832	8,012
Tin plates and terne plates.....	242,123	256,024	238,761	317,896
Iron and steel wire rods.....	145,525	105,148	153,401	167,262
Wire and wire rope.....	2,732	2,475	2,689	3,247
Anvils, forgings, etc.....	967	612	961	1,474
Chains.....	993	634	669	1,023
Total.....	733,260	647,895	1,230,313	1,997,241

The foreign value of the imports of iron and steel manufactures, represented in the above table, together with machinery, cutlery, firearms, and other articles whose weights were not obtainable, was \$56,420,607 in 1887, and \$41,630,779 in 1886. The value of the iron ore imported in 1887 was \$2,206,958, and in 1886 it was \$1,912,437. The imports of pig iron in 1887 included 176,153 tons of spiegeleisen. We import iron ore principally from Spain, Elba, Algeria, and Cuba.

Exports of Iron and Steel.

Our iron and steel exports consist principally of finished articles ready for use, such as firearms, printing presses, hardware, axes, saws, and other tools, shovels, scales and balances, sewing machines, locomotives, and other steam engines, boilers, stores and ranges, machinery, car wheels, castings, etc. We do not export much pig iron or rails, but in 1887 we exported 55 locomotives. In 1887 we exported \$2,427,835 worth of mowers, reapers, ploughs, and cultivators. The following table gives the values of the exports of iron and steel:

Year.	Value.	Year.	Value.
1871.....	\$14,185,359	1880.....	\$15,156,708
1872.....	12,595,539	1881.....	18,216,121
1873.....	14,173,772	1882.....	22,348,834
1874.....	17,312,230	1883.....	22,716,040
1875.....	17,976,853	1884.....	19,290,895
1876.....	13,641,724	1885.....	16,622,511
1877.....	13,549,922	1886.....	14,865,087
1878.....	15,101,899	1887.....	16,235,922
1879.....	14,223,646		

Production of Bessemer Pig in 1887.

States.	Tons.	States.	Tons.
Pennsylvania.....	1,842,449	New York.....	62,626
Illinois.....	549,111	Colorado.....	23,245
Ohio.....	331,144	Maryland.....	18,473
Missouri.....	122,725	Michigan.....	12,766
Wisconsin.....	109,585	Tennessee.....	11,500
West Virginia.....	73,070		
New Jersey.....	63,773	Total.....	3,220,517

A large part of the Bessemer pig produced in the Lehigh and Schuylkill Valleys, and in Maryland, New York, and New Jersey, is made from foreign ores, or foreign ores mixed with native ores.

Furnaces.—The number of steel and iron furnaces in blast in the United States at the close of 1884 was 236; on June 30, 1885, 228; on June 30, 1887, 306, and at the end of 1887, 339. At the close of 1887 there were 583 furnaces in the United States, and 30 new furnaces in course of erection.

Production of Steel.—The production of Bessemer steel ingots in the United States in 1887 was 3,288,357 tons, a gain of 746,864 tons over the production of 1886, nearly double the production of 1885; about seven-eighths of our total production for this year being made by the Bessemer processes. Eleven States contributed to this production, Massachusetts, New York, Pennsylvania, Virginia, West Virginia, Tennessee, Ohio, Indiana, Illinois, Missouri, and Colorado, there being 41 works with 86 converters employed. In 1887 there were 2,290,197 tons of Bessemer steel rails produced.

The open hearth steel production of 1887 was 260,717 tons, an increase of 115,467 over that of 1886. This was made in nine States, by 39 plants. The number of open hearth steel works at the end of 1887 was 53, with 104 furnaces. There were 19,203 tons of steel rails by the open hearth process in 1887. The States producing open hearth steel are New Hampshire, Massachusetts, New York, New Jersey, Pennsylvania, Ohio, Indiana, Illinois, California, and Alabama.

The production of crucible steel in 1887 was 84,421 tons against 80,609 tons in 1886. This was made in ten States—Massachusetts, Connecticut, New York, New Jersey, Pennsylvania, Maryland, Tennessee, Ohio, Illinois, and Michigan.

The production of steel by various minor processes amounted in 1887 to 6265 tons, blister, puddled, and malleable cast steel being included.

In 1887, 2,373,335 tons of steel rails were produced, an increase of 603,796 tons over 1886. These were produced in fifteen States, Pennsylvania furnishing 54 per cent., and Illinois 30 per cent. In 1887 there were 57,362 tons of street rails produced.

The production of steel by all processes in Great Britain and the United States, in 1887, was as follows:

Ingots.	Great Britain.	United States.
Bessemer Steel.....	2,034,403	2,936,033
Open hearth steel..	981,104	322,069
Crucible steel.....	About 100,000	75,376
Other steel.....	Nominal if any	5,593
Total.....	3,545,507	3,559,071

The Presence of Foreign Substances in Steel.—The carbon of course regulates the kind of steel. When it amounts to .04 of one per cent. we get a tensile strength per square inch of about 50,000, increasing to 150,000 lbs. as the carbon rises to .9 of one per cent. Manganese is used up in eliminating more injurious substances in the ore. For example, combining with protoxide of iron, it helps to remove this very injurious oxide, reducing it to iron and oxide of manganese, which passes off in the slag. The presence of much manganese makes the steel very hard and stiff. In plates for ships it varies from .22 to .60 per cent.

Phosphorus tends to make the steel non-homogeneous by being unequally distributed, to make it "cold-short" or brittle when worked cold, and tends to weaken steel that is reheated or subjected to vibration, so that it must be kept below .06 per cent. in ship plates, shapes, and rivets, and below .03 per cent. in boiler stays, plates, and rivets. Pig containing phosphorus is very cheap, and the phosphorus helps in the melting and pouring of the metal, and gives a good elastic twist and strength with less work on the material. So there is naturally a strong temptation to use it on account of cheapness, and the basic processes are apt to rapidly grow in favor. In bridge steel phosphorus is not permitted to be above .05 per cent., and in rails it is limited to .10 per cent.

Silicon tends, in solid castings, to prevent blow-holes and sponginess. The silicon is usually consumed in the furnace when making mild steel, and in ship-plates does not amount to more than .04 per cent.

Sulphur is very injurious, leading to hot short-

ness or brittleness when worked hot. It is not above .03 per cent. in ship steel. Arsenic makes steel cold-short, copper red-short, and antimony both red- and hot-short.

Boiler shell plates are tested the same as the ship plates, but the gange plates are to have an elongation of 29 per cent. in 8 inches.

In the case of gun steel and steel for armor, the specimen is 2 inches between witness marks, cylindrical in shape, $\frac{1}{4}$ inch in diameter. For protective decks the steel to be between 60,000 and 70,000 lbs. and 25 to 23 per cent. elongation, or between 70,000 and 80,000 lbs. with 23 to 19 per cent. elongation, or between 80,000 and 90,000 lbs. with 19 to 12 per cent. elongation. For heavy steel armor, the tensile strength to be 82,000 lbs. and the elongation not less than 20 per cent. Gun steel must be of the very best, and there are tests for the various parts of the gun, the tests for the 8-inch gun being given as an example.

	Tubes.			Jackets.			Hoops.		
	A.	B.	C.	A.	B.	C.	A.	B.	C.
Tensile strength (pounds).....	80,000	72,000	70,000	85,000	76,500	74,000	100,000	90,000	90,000
Elastic limit (pounds).....	28,000	34,000	33,000	40,000	36,000	34,000	50,000	45,000	45,000
Elongation (per cent.).....	20	18	12	18	15	10	18	16	12
Contraction of area.....	30	20	15	30	20	12	30	25	15

ness or brittleness when worked hot. It is not above .03 per cent. in ship steel. Arsenic makes steel cold-short, copper red-short, and antimony both red- and hot-short.

Tests.—Steel is now subjected to rigid tests before being used for structural purposes. For the mild steel which is used for the vessels now building for the Government, test pieces are taken about 16 inches long, with witness marks about 8 inches apart, the sectional area being from .5 to .8 of an inch. These pieces are placed in the testing-machine and subjected to a pull, the amount of which can be accurately measured in pounds. The specimens are first carefully measured to get the exact sectional area, the micrometric gauges used measuring to .001 inch. An initial stress of about 30,000 lbs. to the square inch and kept in continuous action for about a minute, and observations taken to note the corresponding elongation. The weight is then increased gradually, till the cracking of the mill-scale and the unsteadiness of the beam show that the elastic limit is being neared; and when the beam drops suddenly, the weight is recorded as the elastic limit. From this time loads are gradually added till the specimen is broken. The load necessary to produce ultimate fracture is carefully noted and the pieces fitted carefully together, and the increased distance between the witness-mark measured to obtain the elongation. Plates and the shapes, as they are called, such as angle steels, Z bars, bulbs, etc., must show an ultimate tensile strength of 60,000 lbs. to the square inch, and an elongation in 8 inches of 25 per cent. Pieces cut from the finished heat must bend over flat on themselves when cold without breaking, and specimens, after being heated to a dark cherry-red and then plunged into water at 82° F., must bend round a curve whose diameter is $1\frac{1}{2}$ times the thickness of the plate, without cracking. Rivets are to have a tensile strength of from 50,000 to 55,000 lbs. per square inch, and an elongation in 8 inches of not less than 30 per cent., and they must flatten out cold under the hammer to a thickness of one-half the diameter, and hot to a thickness of one-third the diameter, and bend in the form of a hook when cold without showing cracks or flaws.

One of the most important advances in the manu-

facture of steel is in the making of malleable steel castings; the heavy ram sterns, stern-posts, rudder-posts, and struts, that had until recently to be forged out are now cast, and such castings are to show a tensile strength of 60,000 lbs., and an elongation in 8 inches of 10 per cent.

Material is, of course, subject to a rigid surface inspection for laminations, hair-cracks, scale-marks, blisters, pits, snakes, and cobbles. Pits should cause rejection, being due to burning. They occur in the form of small cup-like holes, and must not be confounded with cinder-spots, which are due to cinders or pieces of firebrick being rolled into the plates. Cracks are due to rolled-out blow-holes, while snakes are small lines twisting in every direction, due to foreign substances in the heat separating two masses of pure steel. This should always cause rejection. Cobbles are irregularities due to one side being more heated than another.

Ship plates and shapes can be bought, which will pass the above tests, for about 3.34 cents per lb. Steel castings cost about 16 cents a lb. Steel forgings for guns cost about 30 cents a lb., though the price depends very much on the size, and twelve-inch armor-plates cost about \$675 per ton. Steel rails are now worth about \$27 per ton.

The recent additions to the U. S. navy comprise ten steel-protected vessels, begun in 1887: the Baltimore, Newark, Philadelphia, Vesuvius, and Yorktown, built at Cramps' ship-yard, Philadelphia; the Bennington and Concord, built at Ronch's yard, Chester, Pa.; the Petrel, built at the Columbian Iron Works, Baltimore; and the Charleston and San Francisco, built at the Union Iron Works, San Francisco. In 1888 two armored cruisers were commenced—the Maine, at the New York navy yard, and the Texas at the Norfolk navy yard. The Newark, one of the largest, is a twin-screw, steel-protected cruiser of 4083 tons displacement. She is 328 ft. long, 49 ft. beam, and 18 $\frac{1}{2}$ ft. mean draught. The engines, boilers, magazines, shell-rooms, torpedo spaces, and steering gear are protected by a thick steel deck, resembling a turtle-back, extending fore and aft, and dipping below the water at the sides and ends. The speed is to be 18 knots, and she will carry twelve 6-in. breech-loading rifle guns. The contract price for hull and machinery is \$1,248,000.

In the preparation of this article the following have been drawn from: *The Elements of Metallurgy*, by J. Arthur Phillips; *The Inspection of Structural and Boiler Material*, by Lieut. Commander J. G. Eaton, U. S. N.; and the *Report of the American Iron and Steel Association*. (11. N.)

STEELE, FREDERICK (1819-1868), general, was born at Delhi, N. Y., Jan. 14, 1819. Graduating at the U. S. Military Academy in 1843, he served in the war with Mexico as 2d lieutenant, gaining the brevets of 1st lieutenant and captain by his "gallant and meritorious conduct" at Contreras and Chapultepec. In June, 1848, he was commissioned as 1st lieutenant and ordered to California, where he served till 1853, and thereafter mainly in Minnesota, Nebraska, and Kansas till the civil war, receiving his commission as captain in 1855. In June, 1861, he was advanced to major of the Eleventh Infantry, and in September to colonel of the Eighth Iowa Volunteers, commanding a brigade in Missouri till April, 1862, and taking part in the battles of Dug Spring and Wilson's Creek. He was commissioned brigadier-general of volunteers in January, 1862, and commanded a division in the Army of the Southwest till November of that year, being engaged at Round Hill and in the occupation of Helena, Ark. He was then brevetted to major-general of volunteers and assigned to the Thirteenth Army Corps, which he commanded in the Yazoo expedition and at the capture of Arkansas Post, in January, 1863. Transferred to the Fifteenth Corps, he led a division in the Vicksburg campaign, for his various services in which he was brevetted colonel in the U. S. army, July 4, 1863, and promoted to lieutenant-colonel, Aug. 26, when his division was sent to Arkansas and, Sept. 19, captured Little Rock, from which date till Nov. 29, he commanded the department of that State. He then went to the aid of Gen. Canby in the reduction of Mobile, and, after commanding various divisions in the South, was at the close of the war brevetted brigadier-general in the regular army for the capture of Little Rock, and major-general for services during the war. In December, 1865, he was assigned to the command of the Department of Columbia. On July 28, 1866, he was assigned to the colonelcy of the Twentieth Infantry, and remained in the service till mustered out in March, 1867, on account of failing health. He died at San Mateo, Cal., Jan. 12, 1868.

STEENSTRUP, JOHANN JAPHET SMITH, Danish naturalist, was born, March 8, 1813, at Vang, where his father was pastor of a Lutheran church. He studied medicine but devoted himself especially to natural science, making for this purpose visits to the island of Bornholm (1836), to the north of Jutland (1838), to Iceland (1839-40), to the Scotch Highlands, Faroe Islands, and Norway (1844). In 1843 he obtained the natural history prize offered by the University of Copenhagen. He had already been instructor in mineralogy and botany at Sorø, and in 1845 he was made assistant professor of zoology in the University of Copenhagen, and in 1848 one of the directors of the Royal Museum of Natural History in that city. His works on *The Development of Animals by Alternations of Generation* (1842) and *Researches on Hermaphrodites* (1846) are important contributions to science and have been translated into English and other languages.

STEFFENS, HEINRICH (1773-1845), German philosopher, was born at Stavanger, Norway, May 2, 1773. He studied the natural sciences at Copenhagen, and went thence to Germany to follow the course of Schelling at Jena. On his return to Copenhagen he opened a course of lectures on philosophy, which was promptly suppressed owing to the startling novelty of his ideas. By way of compensation he accepted the chair of philosophy and mineralogy in the University of Halle. A determined foe to the French invasion of Germany, he served through the campaign of the War of Liberation, and after the peace returned to Breslau to teach the natural sciences. He was then called to Berlin to occupy the chair of natural sciences in the university of that city, and for a year occupied the position of

rector of the university. His principal works are: *The Principles of the Philosophy of Nature* (Berlin, 1806); *Anthropology* (Breslau, 1821); *The False Philosophy and the True Faith* (Breslau, 1825); *Christian Philosophy* (Breslau, 1835). He died at Berlin, Feb. 13, 1845.

STEIN, LORENZ, Danish jurist and economist, born at Eckernförde, Nov. 18, 1815. The son of a soldier and left an orphan at an early age, he was brought up as a "child of the regiment" at a military school, where he so distinguished himself by his intelligence and progress that he received a bursary from the king by which he was enabled to continue his studies at the Flensburg School of Science and at the Universities of Kiel and Jena, where he applied himself specially to the study of philosophy and jurisprudence. In 1841 he took his degree at Kiel, and published a *History of Civil Procedure and Present Practice in Denmark* which gained for him a prize from the government that enabled him to visit Berlin and Paris, where his attention was mainly directed to Saint-Simonism. He was thus led to publish a pamphlet upon *Socialism and Communism in Modern France* (Leipsic, 1844), in which the socialist theories were for the first time submitted to a really scientific examination. In Paris, also, he collected materials for his *History of the French Constitution and Law* (3 vols., 1846-48). Meantime he had been created Doctor by the University of Kiel, and in 1846 was appointed professor extraordinary there. When the Schleswig-Holstein question came to be agitated he warmly defended the rights of the duchies in the German press. He took part also in editing the pamphlet of the nine Kiel professors, and saw himself, thereupon, threatened with deprivation. On the rising of the duchies in 1848 he sustained the national cause with more ardor than ever, and was sent by the provisional government to Paris, where he brought out a pamphlet on *The Schleswig-Holstein Question*. Here also he revised his work on the social condition of France, which he brought out anew under the title: *History of the Social Agitations in France from 1789 to the Present Time* (Leipsic, 1849-51, 3 vols.). From this time he devoted himself more especially to economical questions proper, and, having, along with his nine colleagues, been deprived of office on Denmark retaking possession of the duchies in 1852, lived privately in Kiel till 1854, when he repaired to Vienna. Here he was appointed to the chair of the political sciences and became associated with the Minister of State Von Bruck, who called on him for assistance in regard to the Austrian finances. In 1878 he was appointed professor in the law faculty of the University of Vienna, and held this chair till his retirement in 1885. Among his works are: *A System of the Political Sciences* (Stuttgart, 1852-56); *The New Conditions of Specie and Credit in Austria* (Vienna, 1855); *Manual of Political Economy* (Vienna, 1858); *Manual of the Science of Finance* (Leipsic, 1860); *Science of Administration* (Stuttgart, 1865-68); *Army Administration* (1872); *Woman in National Economy* (1886).

STEPHEN, SIR JAMES FITZJAMES, English lawyer and legal author, was born in London in March, 1829, being the son of Sir James Stephen, for whom see ENCYCLOPÆDIA BRITANNICA. He was educated at Trinity College, Cambridge, graduated B. A. in 1852, and was called to the bar at the Inner Temple in January, 1854. He served as recorder of Newark-on-Trent from 1859 to 1869, and in December of the latter year was appointed a law member of the government of India in place of Sir Henry Maine. He held this office till April, 1872, during which time he strove to simplify the laws of India. In 1873 he unsuccessfully contested Dundee, in 1875 was appointed professor of common law of the Inns of Court, and in 1878 became a member of the royal

commission to inquire into the provisions of a draft code relating to indictable offences. In 1879 he was appointed a judge of the High Court of Justice. He has been an active writer on legal subjects, his principal works being *Essays by a Barrister* (1862); *General View of the Criminal Law* (1863); *Liberty, Equality, and Fraternity* (1873); *Digest of the Law of Evidence*, and *Digest of the Criminal Law* (1877), the latter works forming the basis of a bill on indictable offences; and *History of the Criminal Law of England* (3 vols., 1883).

His brother, LESLIE STEPHEN, noted as an author, was born in London, Nov. 28, 1832. He was educated at Eton; King's College, London; and Trinity Hall, Cambridge, where he graduated B. A. in 1854 and M. A. in 1857. He was a fellow and tutor in Trinity Hall for several years, but left Cambridge in 1864 and entered actively into literary pursuits in London. He married Harriet M. Thackeray, daughter of the novelist, and in 1871 became editor of the *Cornhill Magazine*, and continued in charge of it till 1882, when he resigned for the purpose of taking up the extensive work upon which he has been since engaged, the *Dictionary of National Biography*. In May, 1883, Mr. Stephen was elected to the lecturership of English literature at Cambridge. In addition to his editorial and professional work Mr. Stephen has been an active writer, and has contributed largely to the literature of Alpine travel, which he has treated in *The Playground of Europe* (1871). In addition, his works include *Essays on Free Thinking and Plain Speaking* (1873); *Hours in a Library* (3 series, 1874-79), a collection of acute literary criticisms; *History of English Thought in the Eighteenth Century* (1876); *The Science of Ethics* (1882); and *Lives of Johnson, Pope, and Swift* in the "English Men of Letters" series. He edited Fielding's *Works* in 10 volumes, with a biographical essay, in 1882, and has contributed numerous articles to the *Saturday Review* and the *Pall Mall Gazette*. The *Dictionary of National Biography* in which he is assisted by many distinguished writers, is the most complete and accurate work in its special field.

STERLING, a city of Illinois, in Whiteside county, is on the N. bank of Rock river, 109 miles W. of Chicago. It is on the Chicago and Northwestern Railroad, and on a branch of the Chicago, Burlington and Quincy Railroad. Rock river is here crossed by two bridges, one being of iron, 1100 feet long, and costing \$40,000. There is a large dam which furnishes water-power to nearly all the factories, 44 in number. They produce agricultural implements, wagons, carriages, barbed wire, paper, pumps, windmills, and other articles. There are five iron foundries. Sterling has a city hall, 2 hotels, theatre, 3 fine public school buildings, 15 churches, a free public library. It was settled in 1834, and incorporated in 1858. Its property is valued at \$7,000,000. It is surrounded by a rich agricultural district, inhabited by a highly moral community. The population of Sterling in 1880 was 5087.

STEBEN, FRIEDRICH WILHELM AUGUST HEINRICH FERDINAND VON, BARON, a German soldier of distinction in our war of the Revolution, was born, Nov. 15, 1730, in the fortress of Magdeburg, Prussia, where his father was a captain. After finishing his education in a Jesuit college at Neisse and Breslau, he entered the Prussian service in 1747 as cadet in an infantry regiment, and was made ensign in 1749 and lieutenant in 1753. He served in the Seven Years' war and was wounded at the battle of Prague, and distinguished himself at Rosbach. In 1758 he was made adjutant-general, and in 1759 took part in the battles of Kay and of Kunersdorf, where he was again wounded. He was aide to Gen. Knoblauch in his brilliant march into Poland in 1761, and was taken prisoner by the Russians, but was exchanged,

and in 1762 made aide to Frederick the Great, in which capacity he was present at the siege of Schweidnitz, the closing scene in the Seven Years' war. At the peace of 1763 he withdrew from the army, and was presented by Frederick with a valuable lay benefice. He accompanied the Prince of Hohenzollern-Hechingen to several of the courts of Europe, and was by him made grand marshal and general of his guard, which posts he filled for 10 years. In 1777, while on a visit to France, he was induced by Count St. Germain to offer his services to the struggling American colonies, through the agency of Silas Deane. In December, 1777, he set sail with several other officers from Marseilles, and after a perilous passage arrived, in 55 days, at Portsmouth, N. H. Hence he wrote to Congress, offering his service, and saying that the sole motive that brought him was to "serve a nation engaged in the noble work of defending its rights and liberties." Proceeding south he presented himself to Congress at York, Pa., and proposed to enter the patriot force as a volunteer, on the conditions that if his "services were not satisfactory, or if the colonies failed to establish their independence, he was to receive nothing," but if they were successful "he was to be refunded the income he had given up, and be remunerated for his services." His offer was accepted and he proceeded at once to Valley Forge, where he was gladly welcomed by Washington. On looking at the wintry encampment and observing the half-starved, half-clad, and poorly armed soldiers crawling out from their huts, he declared that "no European army could be kept together a week in such a state." He set to work at once, and from that hour our military system assumed a new shape. In May, 1778, Congress appointed him inspector-general of the army, with the rank of major-general, and he took part as a volunteer in the battle of Monmouth in the following June. His services in drilling the officers and men of the army can scarcely be overrated. In 1779 he submitted to Congress a manual of instruction, which, being approved, contributed to introduce a thorough system of discipline. In 1780 he sat as a member of the court-martial that tried Major André, and in the same year was placed in command of the troops in Virginia, at the head of which he was busy in the beginning of 1781 in harassing the British under Gen. Arnold. At the siege of Yorktown Steben took his place as a major-general of the line, and was attached to Gen. Lafayette's division. He was in the trenches when the proposition to surrender arrived, and when Lafayette came to relieve him he refused to leave his post, declaring that the rules of war required that the officer who received the first overtures of surrender must keep his post till terms were agreed on or hostilities resumed. Remaining as a citizen of the United States after the war, he took up his abode in New York City, where he resided for several years. It was only after 7 years' struggle that he succeeded in getting Congress to fulfil its contract, which it did by granting him a pension of \$2,400. Meantime several States had presented him with grants of land. New York gave him a township (now called Steben) near Utica, Oneida Co., and here he built himself a log-cottage, in which he spent the remainder of his days, in the company of North, Popham, Walker, and other of his aides. His lands covered 16,000 acres, but of these he gave away large tracts in gifts to poor soldiers, passing the evening of his life in the healthful occupations of a simple farmer. He died at his cottage, Nov. 28, 1794, and according to his own request was buried near it with the star of honor that he always wore on his breast. A life by Francis Bowen appeared in Sparks' *American Biography*, but a superior one was published by Friedrich Kapp in 1866. (J. H.)

STEUBENVILLE, a city of Ohio, county seat of Jefferson Co., is on the Ohio river, 22 miles above Wheeling. It is on the Cleveland and Pittsburg, and the Pittsburg, Cincinnati and St. Louis Railroads, which here cross the river on a bridge. It has a fine court-house, 3 national banks, 2 other banks, 18 churches, a high school and other schools, 2 daily and 4 weekly newspapers. The industrial works comprise iron rolling-mills, blast furnaces, car-works, machine-shops, white-lead works, breweries, glass factory, paper, flour, and woollen mills, and potteries. It is adjacent to bituminous coal-fields, and has a good supply of natural gas. It is also a trade centre for a farming and wool-growing district. Fort Steuben was erected here in 1787, and the settlement which grew around it was made a city in 1851. Its population in 1880 was 12,033.

STEVENS, ISAAC INGALLS, general, was born, March 28, 1818, at Andover, Mass., and was graduated in 1839 from the U. S. Military Academy, where he ranked first in his class, being commissioned 2d lieutenant of engineers. In 1840 he was promoted 1st lieutenant, and served as adjutant of the engineer corps in the Mexican war, in the course of which he was brevetted captain and major for meritorious conduct at Contreras, Churubusco, and Chapultepec. At the taking of the City of Mexico he was severely wounded. For several years he superintended fortifications on the New England coast, and from 1849 to 1853 was principal assistant and in charge of the office of the U. S. Coast Survey at Washington, D. C. In the latter year he resigned from the army on his appointment to the governorship of Washington Territory. While continuing to hold this office he conducted the pioneer survey of the northern route for a Pacific railroad, an account of which he afterward published. In virtue of his office of governor he was superintendent of Indian affairs, in which capacity he had frequent dealings with the natives, as well as hostile encounters with them. In 1854-55 he concluded treaties with them by which they relinquished more than 100,000 square miles of territory. During his absence, in the latter year, the disaffected Indians rose against the whites. On his return he called out 1,000 volunteers, and after a campaign in 1856 the Indians were subdued and their chiefs slain. During the struggle he caused whites sympathizing with the savages to be shut up in the towns, and when Chief Justice Lander issued a writ of *habeas corpus* for their release, Stevens declared two counties under martial law, seized Lander in his court-room, and kept him prisoner till the end of the war. In 1857 he resigned his governorship and was elected delegate to Congress from Washington Territory for two successive terms (1857-61). On the outbreak of the civil war he hastened from the Pacific coast to Washington, and was appointed colonel of the 79th (Highlanders) N. Y. Volunteers. The men were disappointed at being commanded by army officers and 8 companies mutinied, but by his courage and sound sense Col. Stevens restored discipline, and on his promotion to brigadier-general, Sept. 28, 1861, the men asked to be transferred to his brigade. His first service in this capacity was in the Port Royal expedition, which left Fortress Monroe a month later, in the course of which he, with the co-operation of the gun-boats, attacked and captured the Confederate batteries on the Coosaw. On July 4, 1862, he was promoted to major-general of volunteers, and transferred to Newport News, serving under Gen. John Pope. He took part in skirmishes on the Rappahannock, and was hotly engaged in the second battle of Bull Run, where he distinguished himself. On the morning of Sept. 1, 1862, his division encountered the enemy near Chantilly. Stevens, carrying the colors of the 79th Regiment in his hand, placed himself at the head of his divisions,

and cheered on his men; while thus engaged he was shot through the head and instantly killed.

STEVENS, JOHN (1749-1838), inventor, was born in New York in 1749. His specialty was the problem of steam-navigation. The legislature of the State of New York had offered a monopoly of the navigation of the Hudson to anyone who should construct a boat with a speed of 3 miles an hour, and, as early as 1789, Stevens presented a memorial stating that he had perfected his plans. In 1804 he built a vessel with twin screws that navigated the Hudson, but failed to attain the required speed. Livingston (Stevens' brother-in-law) and Fulton then acquired the monopoly. In 1807 Stevens built the paddle-wheel steamer *Phoenix*, that plied for six years on the Delaware. Professor Renwick, who gives the best account of Fulton's boat *Clermont*, in 1807, says: "The Stevenses [father and son] were but a few days later in moving a boat with the required velocity," and, "being shut out of the waters of New York by the monopoly of Livingston and Fulton, Stevens conceived the bold design of conveying his boat to the Delaware by sea, and this boat, which was so near reaping the honor of the first success, was the first to navigate the ocean by the power of steam." In 1812 Stevens designed a revolving, iron-plated steam battery, essentially on the principle afterward embodied in the monitors. In the same year he published an essay on railroads, indicating the methods of operating them by steam, and suggested the building of a railway between Albany and Lake Erie. He was the engineer of the Camden and Amboy Railroad. To Stevens may be ascribed the paternity of the American patent law. In 1790 his petition to Congress for protection to American invention was referred to a committee, which reported a bill that became law, April, 1790. He died at Hoboken, N. J., March, 1838.

His son, ROBERT LIVINGSTON STEVENS (1787-1856), was born at Hoboken, N. J., March, 1787. From his 17th year he was associated with his father in experiments in steam-navigation and ship-building. In the hull of his father's vessel the *Phoenix*, which he navigated from New York to the Delaware in 1808, he introduced concave water-lines, this being the first application of the wave-line in ship-building. During the war with England he was engaged, in 1813-14, in making a bomb that could be fired from a cannon instead of from a mortar, and ultimately sold to the government percussion oblongated shells for smooth-bore guns. On Fulton's death, in 1815, the speed attained by steam-boats on the Hudson was under 7 miles an hour; about this date Stevens produced the Philadelphia, with a rate of 8 miles. From this time till 1832 he kept accelerating the rate, till the North American attained 15 miles. In 1821 he originated the present form of ferry-boats and ferry-slips. In 1822 he introduced anthracite into his furnaces, and, soon after, into his steamers. In 1836 he introduced the T-rail on the Camden and Amboy Railroad, of which he was president. In 1842 he was commissioned by government to build an iron-plated war-vessel or battery, shell-proof, and to be driven by screws. This was left unfinished at his death, which occurred at Hoboken, April 26, 1856.

JAMES ALEXANDER STEVENS, brother of the preceding, was born in New York in 1790, graduated at Columbia College in 1808, and was admitted to the New York bar, 1811. He also was connected with steam-navigation, and, in conjunction with Thomas Gibbons, established the Union Line between New York and Philadelphia. This resulted in a suit, memorable for its decision, that placed all the waters of the United States under government jurisdiction.

EDWIN AUGUSTUS STEVENS (1795-1868) was associated with his brothers in steam-navigation, and in

conjunction with them established passenger and tow-boats on the Hudson and other rivers. On the outbreak of the civil war he and James A. offered to complete the iron-clad battery left unfinished by their brother Robert, on condition that government should remunerate them for their outlay in the event of its proving a success; and, for the purpose of showing the reasonableness of the proposal, they fitted out, at their own cost, the little iron-clad Naugatuck, which rendered valuable service in engagements on the James River. Nevertheless the offer was declined, whereupon Edwin himself expended considerable sums on the battery, and on his death bequeathed it, with \$1,000,000 to complete it, to the State of New Jersey. This sum proving insufficient, the vessel was sold by the State in 1874 to the U. S. government, but, Congress having failed to make the appropriation for the purchase, it remained at the dock of Hoboken uncompleted. At an early period Edwin purchased the entire site on which the city of Hoboken is built, by which, as well as by his other enterprises, he acquired an immense fortune. He endowed the Hoboken high school, and bequeathed in all nearly \$1,000,000 to establish the Stevens Institute of Technology at the same place. He died at Paris, Aug. 8, 1868.

STEVENS, WILLIAM BACON (1815-1887), a bishop of the American Episcopal Church, was born at Bath, Maine, July 13, 1815. Having early lost his father, he was brought up in the residence of his grandparents in Boston. He belonged to the Congregational Church, and expected to enter its ministry, but on account of ill-health he left Phillips Academy, Andover, and took a sea-voyage around the globe, spending five months in the Sandwich Islands and five more in China. On his return he studied medicine at Savannah, Ga., but received his degree from Dartmouth College in 1837. While engaged in practice at Savannah he organized the Georgia Historical Society, and edited two volumes of its *Collections*. His health having been restored he took up the study of theology under Bishop Stephen Elliott, and was ordained in the Episcopal Church in 1843. He was then called to be professor of belles-lettres and moral philosophy in the University of Georgia, at Athens, and, having been appointed by the legislature State historian, he published his *History of Georgia* (2 vols., 1847-59), which was highly commended by Bancroft and Sparks. In 1848 he was chosen rector of St. Andrew's Church, Philadelphia, and, removing to that city, became noted as a pulpit orator. In 1861 he was chosen assistant bishop of Pennsylvania, and in 1865 succeeded Bishop Alonzo Potter in charge of the diocese. Under his episcopal direction the religious and benevolent work of the church was diligently prosecuted, and in a few years the diocese, originally coterminous with the State of Pennsylvania, had to be twice divided. Bishop Stevens retained Philadelphia and four adjoining counties, which still preserved for Pennsylvania its relative rank in numbers and influence among the American dioceses. His work was at times seriously interrupted by ill-health, and in 1886 he was obliged to ask for an assistant. He resumed his activity, however, and was engaged in performance of public duty until within a few weeks of his death. He died at Philadelphia, June 11, 1887. Besides the historical works noted, he published some charges, devotional treatises, and memorial discourses. For some years he had oversight of the American Episcopal churches on the Continent of Europe, and in 1885 he preached the sermon before the Pan-Anglican Council at Lambeth.

STEVENSON, ROBERT LOUIS, British author, was born at Edinburgh in 1845. He was grandson of the engineer Robert Stevenson, famous for his building of light-houses (for whom, see ENCYCLOPÆ-

DIA BRITANNICA). He was educated at the university of his native city, and from it obtained the degree of M. A. While still an undergraduate, he had started a college magazine. He travelled on the Continent of Europe and across the United States. His first book to attract attention was *Travels with a Donkey in the Céremes*. But still more popular were his *Treasure Island*, *Kidnapped: a Story of the Rebellion of '45*, *The Dynamitards*, and others.

STEVENSON, WILLIAM FLEMING (1832-1886), Irish Presbyterian minister, was born at Strabane, Sept. 20, 1832. He graduated at the University of Glasgow and, after studying theology in Scotland and Germany, was licensed to preach in 1856. His first work was as city missionary in Belfast, and in 1860 he took charge of a newly formed Presbyterian church in Dublin. He was also busy in contributing to *Good Words* and other periodicals. In 1871 he was called to assist in directing the foreign mission work of the Irish Presbyterian General Assembly. In 1873 he attended the meeting of the Evangelical Alliance at New York, and in 1877 he travelled around the world in the interest of missions. In 1881 he was made moderator of the Irish General Assembly. He was a member of the senate of the Royal University, and was made chaplain to Lord Aberdeen, when viceroy of Ireland. He died at Rathgar, Dublin, Sept. 16, 1886. His published works are *Praying and Working* (1862); *Lives and Deeds Worth Knowing* (1870); *Hymns for Church and Home* (1873).

STEWART, CHARLES (1778-1849), rear-admiral, U. S. N., was born of Irish parents at Philadelphia, July 28, 1778. His father died two years later, leaving his widow, with four children, in straitened circumstances. Charles entered the merchant service as cabin boy at the age of 13, and rose to the command of an Indiaman before he was 20. In 1798 he entered the navy as lieutenant and served on board the frigate *United States* against the French privateers in West India waters. In 1800 he was appointed to command the schooner *Experiment*, and in these seas captured the French schooner *Deux Amis* and, soon after, the *Diana*, of 14 guns, retaking several American vessels which had been made prizes by the French. The same year he rescued 60 women and children who had been wrecked when escaping from the revolution in Santo Domingo, which service the Spanish governor of the island acknowledged in a letter of thanks to the President. In 1804, in command of the brig *Siren*, Stewart took part in the naval operations under Preble against Tripoli, co-operating with Decatur in the destruction of the *Philadelphia*, which had fallen into the hands of the Dey. In 1806 he was promoted to captain. From 1808 to 1812 he was employed in the merchant service, but re-entered the navy in the latter year on the outbreak of war with Great Britain. In the summer of 1813 he took command of the *Constitution* and sailed from Boston on a cruising expedition to the coasts of Guiana and the Windward Islands, capturing the British war-schooner *Picton*, of 14 guns, a letter-of-marque under her convoy, and several merchant vessels. In December, 1814, he set out on a second cruise on board the *Constitution*, then mounting 52 guns, with 470 men, and on Feb. 20, 1815, after an engagement of 50 minutes, captured the British war-ship *Cyane*, of 34 guns and 185 men, and the sloop of war *Levant*, of 21 guns and 156 men. The British loss was stated as 41; Stewart's was 3 killed and 12 wounded. A British fleet approached while he was lying at St. Jago, Cape do Verde, from which he adroitly escaped, carrying with him the *Cyane*; the *Levant* was, however, recaptured. For these services he received from Congress a vote of thanks, a sword, and a gold medal; from the legislature of Pennsylvania, a vote of thanks and a sword; and from New York, the freedom of the

city. From the public he received the flattering sobriquet of "Old Ironsides." From 1816 to 1820 he was on the Franklin, in command of the Mediterranean squadron, and from 1820 to 1824 of that of the Pacific, where he vindicated the rights of American commerce by compelling the annulment of a paper blockade. From 1830 to 1832 he was a commissioner of the navy, and, 1838 to 1841, commanded the Philadelphia navy-yard. In 1842 and 1843 he was in charge of the home squadron, and again of the Philadelphia navy-yard in 1844 and from 1854 till 1861. In 1862 he was made rear-admiral on the retired list. He died at Bordentown, N. J., Nov. 7, 1869, having been in the service 71 years and senior officer for 19. In 1835 his daughter, Delia Tindor, was married to John Henry Parnell of Avondale, County Wicklow, Ireland, by whom she is mother of Charles Stewart Parnell (*q. v.*).

STILES, EZRA (1727-1795), educator, was born at North Haven, Conn., Nov. 29, 1727. His father was pastor of the church at that place and published some religious treatises. The son graduated at Yale College in 1746, became a tutor there, and studied theology. After being licensed to preach he turned to the law, and was admitted to the bar in 1753. Three years later, however, he was ordained pastor of a church at Newport, R. I., but during the occupation of that city by the British he removed to Portsmouth, N. H. He was called to be president of Yale College in 1778, and held that position till his death, meantime discharging the duties of various professors. He died, May 12, 1795. He had a high reputation for learning of various kinds, from the ancient languages to modern science. He made some of the first electrical experiments in New England, and taught all the natural sciences. Besides some sermons, he published a *History of the Three Judges of Charles I.* (1794), and left incomplete an *Ecclesiastical History of New England*. His diary and other writings are preserved in Yale College library. His *Life* was written by his son-in-law, Dr. Abiel Holmes (1798) and Prof. J. L. Kingsley (1842).

STILLE, CHARLES JANEWAY, historian and educator, was born at Philadelphia, Sept. 23, 1819. He graduated at Yale College in 1839, and was admitted to the bar. During the war for the Union he was active in the cause of the U. S. Sanitary Commission (*q. v.*), and afterward wrote its history. He also obtained note by his pamphlet, *How a Free People Conduct a Long War* (1862), and some other publications. In 1866 he was appointed professor of history in the University of Pennsylvania (*q. v.*), and in 1868 was made provost of that institution. From his first connection with the university he endeavored to infuse a new spirit into it, advocating the enlargement of its courses of study, and especially promoting the scientific department. The result of these efforts is partly seen in the new buildings of the university. Dr. Stillé retired from his position in 1880, and has since devoted himself to historical research, publishing *Studies in Medieval History* (1881), and various monographs on American history.

His brother, ALFRED STILLÉ, physician, was born, Oct. 30, 1813. He graduated from the University of Pennsylvania in 1832, and from its medical department in 1836. He then studied medicine in Europe, and in 1839 became resident physician at the Pennsylvania Hospital. In 1854 he was made professor of the theory and practice of medicine in Pennsylvania Medical College, and held this position till 1859. In 1864 he was elected to a similar chair in the University of Pennsylvania, and held it for twenty years, then becoming professor emeritus. He has also lectured before various medical societies, and was president of the American Medical Association in 1871. He has published many professional treatises, including *Elements of General*

Pathology (1848); *Therapeutics and Materia Medica* (1860); and *Epidemic Meningitis* (1867). With J. M. Maisch he prepared the *National Dispensatory* (1879), and edited the second edition of *Medical Jurisprudence*, which had originally been prepared by his brother Dr. Morilton Stillé (1822-55) and Dr. Francis Wharton.

STILLWATER, a city of Minnesota, county seat of Washington Co., is on the west bank of St. Croix river, which here expands into a lake, 18 miles N. E. of St. Paul, with which it is connected by railroad. It contains a fine court-house, 2 national banks, 12 churches, a high school, a public library, a penitentiary, 1 daily and 3 weekly newspapers. It has also an iron foundry, flour- and saw-mills, and carries on a large trade in pine-lumber. Its population in 1880 was 9055.

STÖCKER, ADOLF, German clergyman, was born at Halberstadt, Dec. 11, 1835. He was educated in his native town and at the Universities of Halle and Berlin until 1857. Having been ordained in the United Evangelical Church, he became pastor at Seggerde in 1863. In the war of 1870 he was chaplain to a division of the German army, and in 1874 he was called to Berlin as court and cathedral preacher. He has published several sermons and addresses, but is chiefly noted as an advocate of Christian socialism and as a leader in the agitation against the increasing influence of the Jews in Germany.

STÖCKHARDT, JULIUS ADOLF (1809-1886), German chemist, was born, Jan. 4, 1809, at Röhrsdorf, Saxony. He was classically educated, graduated in natural science as pharmacist of first class in 1833, and received the degree of Ph. D. at the University of Leipsic in 1838. In 1834 he travelled in England, France, and Belgium, and he revisited the last two in 1843, to perfect his technical knowledge. In 1838 he taught at Dresden, and next at Chemnitz, and was appointed inspector of drugs. His lectures before the Chemnitz Agricultural Society began a popular movement, the first-fruit of which was the founding at Möckern, Saxony, in 1852, of an experimental station. The number of these institutions in Europe and America now exceeds one hundred. The movement has resulted in a wide diffusion of knowledge of chemical principles as applied to the soil. In 1848 he became the first occupant of the chair of agricultural chemistry in the Royal Academy of Tharand. He died there June 1, 1886. In periodical literature he was editor of *Polytechnisches Centralblatt* (1846-49); *Zeitschrift für deutsche Landwirthe* (1850-55); *Der Chemische Ackersmann* (Leipsic, 1855-76). His other publications are, *Untersuchung der Zwickauer Steinkohle* (1840); *Erkennung und Anwendung der Gifffarbe* (1841); *Schule der Chemie* (1846), translated as *Principles of Chemistry*, New York; *Chemische Feldpredigten* (*Agricultural Chemistry*, Phila.); the last-named two works are translated into several languages. Stöckhardt ranks next to Liebig in aptness for popularizing science rather than in original research.

STOCKTON, a city of California, county seat of San Joaquin Co., is on Stockton Creek, a navigable branch of the San Joaquin river, which flows 3 miles westward. It is on the Central Pacific Railroad, 92 miles E. of San Francisco, and has also local railroads. It has a court-house, several banks, 15 churches, a convent, a high school and other schools, a theatre, 2 public libraries, 2 daily and 7 weekly newspapers, and the State asylum for the insane. Its supply of water is chiefly from artesian wells. It was settled in 1849, and in 1880 its population was 10,282.

STOCKTON, RICHARD (1730-1781), a signer of the Declaration of Independence, was born near

Princeton, N. J., Oct. 1, 1730. His great-grandfather came from England in 1670, and purchased a tract of 6400 acres, including the site of Princeton, the property largely remaining in the family. Richard was graduated at Princeton in 1748, and, after studying law in Newark, was admitted to the bar in 1754, where he acquired repute and a competent fortune. In 1766-67 he visited Great Britain, and while in Scotland prevailed on Dr. Witherspoon to accept the presidency of Princeton College. In 1768 he became a member of the executive council of the province, and in 1774 judge of the Supreme Court of New Jersey. In this same year he submitted to Lord Dartmouth "An Expedient for the Settlement of the American Disputes." On this failing to effect its purpose, he allied himself with the patriot party, and in 1776 was chosen a member of the Continental Congress that met in Philadelphia, where he was one of the signers of the Declaration of Independence. In September of this year he was chosen one of a committee to inspect the Northern army, and on Nov. 30 was seized by night in Monmouth, N. J., and committed to the common prison of New York, where he underwent treatment that seriously affected his health and, ultimately, conduced to his death. Meanwhile his library, one of the finest in the country, had been burned and his land laid waste, so that he was reduced to severe pecuniary straits. He died at Princeton, Feb. 28, 1781. In 1893 the State of New Jersey placed his statue in the Capitol at Washington. His wife, ANNIS BOUDINOT, was a poetess of no mean merit. One of her poems, addressed to Washington after the surrender of Yorktown, elicited from the patriot chief a courtly acknowledgment; another was sung by young ladies while strewing flowers on the path of the hero on his passage through Trenton on his way to his first inauguration at New York.

His son, RICHARD STOCKTON (1764-1828), senator, was born near Princeton, April 17, 1764, studied law in Newark, and was admitted to the bar in 1784. He rose rapidly to the head of the profession in the State; was a presidential elector in 1792 and 1801; United States senator 1796-99; and representative in Congress 1813-15, declining further candidacy. He received the degree of LL. D. from Queen's (now Rutgers) College in 1815, and from Union in 1816. He died near Princeton, March 7, 1828.

ROBERT FIELD STOCKTON (1795-1866), son of the preceding, commodore, was born in Princeton, Aug. 20, 1795. He left Princeton College before completing his course, and in 1811 entered the navy as a midshipman, at once distinguishing himself for gallantry, especially in the defence of Baltimore against the British, for which, in 1814, he was promoted to lieutenant. On the declaration of war with Algiers he sailed with the Decatur to the Mediterranean, but was transferred, as 1st lieutenant, to the Spitfire, in which he took part in the capture of the Algerine frigate Mahonda, and in 1815 headed the boarders in the capture of the corsair Esledio. In 1821 he went to Africa in command of the Alligator, and aided the Colonization Society (q. v.) in acquiring by purchase from native chiefs the territory now constituting the Republic of Liberia. While engaged in this service the Alligator was fired on by a Portuguese letter-of-marque, which mistook it for a pirate. An engagement of 20 minutes sufficed to capture the assailant, which, however, was subsequently returned to Portugal. By his capture of the French slaver Jeune Eugénie Lieutenant Stockton established the legality of seizing slavers under a foreign flag. In 1823-24 he was employed on the survey of the coast of the Southern States. From 1826 to 1838 he was on leave at Princeton, and took an active part in politics as a follower of Gen. Jackson. In 1838 he served as

flag-officer in the Mediterranean, and on his promotion to captain on Dec. 8 was recalled. In 1841 he was offered by Pres. Tyler a seat in the cabinet as secretary of the navy, but declined office. He was one of the first to advocate a steam navy, and prepared the plans for the steam sloop of war Princeton, which was built at Philadelphia, 1842-44, and was given command of it. On a trial-trip on the Potomac in the latter year one of her guns burst, causing the death of five persons, including the Secretaries of war and the navy. A court of inquiry entirely exonerated Captain Stockton. He next sailed to Texas as bearer to its government of the annexation resolutions. In the Mexican war he was commander-in-chief of the squadron on the Pacific, and in 1846, by proclamation, assumed command of all American forces on the coast, conquering California and establishing the authority of the United States. In 1847 he was relieved, and returned home overland, being received with honor by all parties. The New Jersey legislature gave him a vote of thanks and a reception. In 1850 he resigned from the navy, and in 1851 was elected to the U. S. senate, where he promoted the abolition of flogging in the navy. He resigned his seat in 1853, and retired to private life, dying at Princeton, Oct. 7, 1866.

His son, JOHN PORTER STOCKTON, senator and lawyer, was born in Princeton, Aug. 2, 1826. He was graduated at Princeton, 1843, studied law, and was admitted to the bar, 1850, and immediately attained a high position in his native State. He was appointed by its legislature a commissioner to simplify proceedings in the courts of law; in 1857 was sent as U. S. minister to Rome; in 1865 was chosen by a plurality vote to the U. S. senate, but this being challenged he was unseated by a vote of 23 to 21, March 27, 1866. He was re-elected in 1869, serving one term. In the Senate he advocated with effect the establishment of life-saving stations on the coast. In 1877 he was appointed attorney-general of New Jersey, and was re-elected in 1882 and 1887, in which office he has consistently sustained the system of railroad taxation. Ever since 1864 he has been delegate-at-large to all the Democratic national conventions. In 1882 Princeton conferred on him the degree of LL. D.

STODDARD, RICHARD HENRY, poet, was born at Hingham, Mass., in 1825. He was a contributor to the *Knickerbocker Magazine*, and published his first collection of poems, *Foot-Prints*, in 1849, and a second collection in 1851. After his marriage to Elizabeth D. Barstow, in 1852, he settled in New York, where he was employed in the custom-house. He has since been prominently identified with the literary life of the metropolis. In recent years his sight has been much impaired. Among his publications are *Songs of Summer* (1857); *Town and Country* (1857); *The King's Bell* (1863); *The Book of the East* (1871). He has also written some prose works and tales for the young, and edited various collections of English and American poetry. He excels as a lyric and imaginative poet and is a successful writer of blank verse.

STONE, CHARLES POMEROY, general, was born, Sept. 30, 1824, in Greenfield, Mass. He graduated at West Point in 1845, and became 2d lieutenant in the ordnance. In the Mexican war he served from Vera Cruz to the capture of the City of Mexico, and was brevetted in 1847 for gallant and meritorious conduct in the battles of Molino del Rey and Chapultepec. In 1848 he obtained leave of absence to visit Europe, with the object of improving in his profession. In 1851 he was ordered to California, where he constructed the Benicia arsenal, acting, at the same time, as chief of ordnance for the division of the Pacific. Resigning in 1856, he engaged in the banking business in San Francisco till appointed, next year, by the Mexican government, chief of a

scientific commission to survey and explore its lands in Sonora and Lower California. From this work he was called on Jan. 1, 1861, to become colonel and inspector-general of the militia of the District of Columbia. He was here engaged, under Gen. Winfield Scott, in disciplining volunteers, and on May 17 he was made brigadier-general of volunteers and put in charge of the defences of Washington. Under Gen. Patterson he led a brigade in the latter's Shenandoah campaign, and from August, 1861, till February, 1862, was in command, under McClellan, of the corps of observation of the Army of the Potomac. Having, on Oct. 20, 1861, been ordered to make a feint of crossing the Potomac at Ball's Bluff, as if with the view of attacking the enemy there, he, on his own authority, converted the feint into a real attack and was disastrously repulsed on the next morning. There was a popular outcry against the commander, which increased after Congress met in December. On Feb. 9, 1862, he was arrested and placed in confinement in Fort Lafayette, New York harbor, where he lay till Aug. 16th. He was then released, without any explanation. In May, 1863, he was ordered to duty in the Department of the Gulf, where he took part in the siege of Port Hudson and took part in receiving the surrender of the place, July 8, 1863. Selected by Gen. Banks as his chief of staff, he was present at the battles of Sabine Crossroads and Pleasant Hill (April 8 and 9, 1864). On April 4, 1864, he was honorably mustered out as brigadier-general of volunteers, and on Sept. 13 resigned his commission as colonel of the 14th Infantry. In 1870 he entered the service of the Khedive of Egypt and was made chief of the general staff of the army. Subsequently he was made temporary chief of the cadastral survey, and was president of the Geographical Society. When the American officers were mustered out of the Egyptian service, in 1879, Stone alone remained, and held his position of chief of the staff till the insurrection of Arabi Pacha. In 1883 he resigned and returned to the United States, decorated with several orders conferred by Ismail Pacha. Since his return he has held the posts of engineer-in-chief for the Florida ship-canal and transit company, and to the committee for the erection in New York harbor of Bartholdi's statue of Liberty Enlightening the World.

STONE, WILLIAM LEETE (1792-1844), author, was born, April 20, 1792, at New Paltz, N. Y., his father having been a soldier in the Revolutionary war. He spent part of his youth on his father's farm at Solus, N. Y., which was then in a wilderness, and there met with adventures and gained experiences he afterward embodied in his border tales. At the age of 17 he became a printer, and in 1813 he was editor of the *Herkimer American*, on which Thurlow Weed worked as a journeyman. He subsequently edited political papers in Hudson, Albany, and Hartford, besides conducting at Hudson a literary periodical entitled *The Lounger*, and at Hartford, in conjunction with J. M. Wainwright (afterward bishop) and Samuel G. Goodrich ("Peter Parley"), *The Knights of the Round Table*. From 1821 till his death he was one of the proprietors and editors of the *New York Commercial Advertiser*, employing its columns to advocate, among other objects, the cause of abolition of slavery and that of compulsory education. Soon after the Morgan tragedy he, although himself a freemason, addressed a series of letters to John Quincy Adams (afterward collected and published at New York, 1832), urging the abandonment of Freemasonry because it had outlived its usefulness. In 1841 he was sent by Pres. Harrison as U. S. minister to the Hague, but was recalled the same year by Pres. Tyler. He was chosen, in 1844, the first superintendent of the public schools of New York City, and in this capacity had a controversy

with Archbishop Hughes in regard to the use of the Bible in schools. His influence for good was felt in the city in many directions. He especially interested himself in the institution for the deaf and dumb and the society for the reformation of juvenile criminals. Mr. Stone died at Saratoga Springs, Aug. 15, 1844. He was a prolific author, especially in the department of local history. Among his publications were *Life of Maria Monk* (1836); *Letters on Animal Magnetism* (1837); *Life of Joseph Brant* (2 vols., 1838; later edition by his son, W. L. Stone, 1865); *Border Wars of the American Revolution* (2 vols., 1839); *Poetry and History of Wyoming* (1841; new ed., 1864); *Life of Red Jacket* (1835; new edition, with a life of the author, by W. L. Stone, Jr., 1866); and *Life of Uncas and Miantonomoh* (1842).

STONEMAN, GEORGE, general, was born, Aug. 8, 1822, at Busti, Chautauqua county, N. Y. In 1846 he graduated at West Point, and was assigned to the First Dragoons. In 1847 he went, as quartermaster of the Mormon battalion, to California, and remained in active service on the Pacific coast till 1857, when he was promoted captain and ordered to Texas. While in command of Fort Brown, in that State, his superior officer, Gen. D. E. Twiggs (who joined the secessionists, making over to them his army together with the government stores), ordered him to surrender the national property under his charge. This order Stoneman refused to obey, then evacuated the fort and proceeded by sea to New York. In May, 1861, he was advanced to major, and in August to brigadier-general and chief of cavalry of the Army of the Potomac, commanding this arm during McClellan's Peninsular campaign in 1862. After the capitulation of Yorktown his corps overtook the Confederate force, and so brought on the battle of Williamsburg. After the second Bull Run fight, he got the command of Gen. Phil. Kearney's division, and in November, 1862, was made major-general of volunteers, and put in charge of the Third Army Corps in succession to Gen. S. P. Heintzelman, leading it at Fredericksburg, Dec. 13th. In April and May, 1863, he led a cavalry corps in the raid toward Richmond, and from January till April, 1864, was in command of the Twenty-third Corps. When Gen. Grant reorganized the armies operating before Richmond, Gen. Stoneman was assigned to a cavalry corps in the Department of the Ohio, and served under Sherman in the Atlantic campaign of 1864, taking an active part in the operations; among others, conducting a raid for the capture of Macon and Andersonville. Being captured on July 31 at Clinton, he was kept a prisoner till Oct. 27. During February and March, 1865 he had command of the district of Eastern Tennessee, and in March and April was leader of an expedition to Asheville, N. C., being engaged at Wytheville, in the capture of Salisbury, and at Asheville. In June, 1866, he was made colonel of the 21st Infantry, and was brevetted, in succession, colonel, brigadier general, and major-general. In August, 1871, he resigned from the army, and took up his residence in California, of which State he was governor from 1883 till 1887.

STONE RIVER, OR MURFREESBORO', BATTLE OF. When Gen. Bragg, on crossing the Cumberland River after the battle of Perryville (Oct. 8, 1862), perceived himself no longer pursued, he halted his forces, numbering some 40,000, at Murfreesboro' on the Stone River and the Nashville and Chattanooga Railway, about 30 miles S. E. of Nashville. On Oct. 27 Gen. W. S. Rosecrans was transferred to the command of the Union Army of the Ohio or Cumberland, which at this time lay around Bowling Green and Glasgow in Kentucky. On his arriving, on Oct. 30, he found the force in a sadly demoralized condition, and reduced in numbers from 100,000 to 65,000. With the exception of the city of Nash-

vill—weakly garrisoned and poorly supplied—it had nothing to show for its nine months' campaign. The district was scoured by Confederate cavalry under Capt. J. H. Morgan and Col. N. B. Forrest, who rendered it most difficult to keep up communications with the Union depot of supplies at Louisville. After reorganizing the army and replenishing its ammunition, he took immediate steps to avert the danger with which Bragg's proximity menaced Nashville. By Nov. 7 he had the main part of his forces concentrated in front of that city, southward, and covering the roads leading in that direction. To insure the maintenance of communication with Louisville the main part of his centre division was stationed at Gallatin. For about six weeks he lay thus, employed in collecting supplies of various kinds preparatory to a movement upon Bragg. During this period his men were engaged in frequent skirmishing conflicts with the enemy, among which was the surprise of the Union Col. Moore and capture of 1500 men by Morgan's rough-riders at Harts-ville on Dec. 1st. But the hour for more important movements was at hand. Bragg had no idea that Rosecrans would undertake a winter campaign and had sent away a large portion of his force—one section (cavalry) into West Tennessee, to annoy Grant; the other into Kentucky, to break up the railroad forming Rosecrans' sole means of communication with his depots at Louisville. The latter commander judged that the opportunity was not to be let slip and at once took action.

At dawn of Dec. 26 the Union army moved southward: McCook, with 3 divisions (16,000 men), along the Nolensville pike toward Triune; Thomas, with two divisions, Negley's and Rosecrans' (13,500), by the pike on his right to fall in by cross-roads to Nolensville; and Crittenden, with 3 divisions (13,300), on the Murfreesboro' pike toward Lavergue. The plan given out was that McCook should attack the Confederate general, Hardee, who was reported lying with a large force at Triune, 7 miles south of Nolensville, and, in the event of Hardee's having to retreat, that Crittenden should assail him at Stewart's Creek, while Thomas was to come in on his left flank. These movements were to be covered by Brig.-Gen. D. S. Stanley, chief of cavalry. McCook (skirmishing all the way) reached Nolensville in the evening and rested there, with Thomas on his right, who closed Negley's division on Nolensville. Crittenden, with the left, reposed near Lavergue. Late at night Rosecrans, who had left Nashville at noon, arrived at McCook's headquarters.

On McCook's arrival before Trinne next day (27th) he found that Hardee had retired, and he rested there for the night. Crittenden the same day reached Stewart's Creek. Next day was Sunday, and a day of almost general rest. On the morning of Monday (29th) McCook pushed on from Triune to Wilkinson's Cross, 6 miles from Murfreesboro', while Crittenden, moving on the Murfreesboro' pike, skirmished forward to the West Fork of Stone River, within a short distance of Murfreesboro'. In the afternoon Palmer signalled headquarters at Lavergue (erroneously) that the Confederates were evacuating the village, and Harker of Crittenden's was ordered to cross the stream and occupy it. His brigade on crossing found Breckenridge in strong force in front, and Crittenden wisely recalled him. Next morning McCook moved close up to Stone River, a little west of the town, and before evening nearly the whole Union force stood in an irregular line, more than three miles in length, in front of the Confederates, who held a strong position before Murfreesboro'. During the night of the 30th both armies prepared for battle. Crittenden was on the Union left, resting on Stone River; Thomas held the centre; McCook stood on the right. Bragg disposed his forces—the

right under Breckenridge in the rear of Stone River; Polk in the centre, and Hardee on the left, both in front of the stream. At 9 p. m. the Federal commanders met at headquarters and Rosecrans explained his plan of battle. The left and centre were to be thrown heavily on Breckenridge at daybreak, crush him, wheel rapidly, and attack the front and flank of the Confederate centre, and then, sweeping through Murfreesboro', gain the rear of the centre and left, cut off their line of retreat, and so destroy the army in detail.

Before sunrise of the 31st Van Cleve's division of Crittenden's crossed the river, and Wood was ready to follow him in support. Meanwhile a counter-movement of the Confederates entirely deranged Rosecrans' scheme. Bragg had decided to attack the Union right at dawn, and with this view had massed his troops on his left under Hardee in front of McCook. In the dim light of dawn these emerged on a sudden from the close woods. Cleburne led with four brigades and charged McCook's extreme right before Van Cleve had moved. Cheatlam's and McCown's divisions struck nearer the centre, and, despite a storm of missiles, fell heavily on the brigades of Willich and Kirk and forced them back in confusion. Kirk was seriously wounded; Willich was taken captive; Edgerton's battery and part of Goldspeed's were captured and turned on the fugitives; a large number of prisoners were taken. Following up this success, the victors fell on McCook's left, composed of the divisions of Sheridan and J. C. Davis, striking them on the left flank. After a severe struggle, especially on the part of Sheridan, these also gave way and fell back almost to the Nashville pike. In this onset Houghtaling's battery and part of Brash's were lost.

It was now 11 o'clock. The Union right wing, comprising one-third of the army, was completely broken up, and the Confederate cavalry were in Rosecrans' rear. It seemed as if the day were lost. The Union troops had been driven from nearly half the ground they held at dawn, and they had lost many hundreds of men. The brunt of the battle fell now on Thomas in the centre, who had been reinforced by Rousseau's reserve division. The enemy pressed toward his rear till they reached a position whence they poured a storm of cross-fire on Negley and Rousseau. This compelled Thomas to withdraw from the cedar-wood he occupied and form line in the open ground between the woods and the Nashville pike. This position he held firmly, and enabled Rosecrans to readjust his line in accordance with the position of affairs. The fight was not yet over. Palmer's division, on the right of the Union left wing, was next assailed in front and rear. His right brigade, under Craft, was beaten back, and the assailants fell on the second brigade under W. B. Hazen. This broken, the Confederate victory was complete. Hazen felt that on him depended the issue of the battle, and, at a terrible sacrifice, held his ground till Rosecrans was able to form his new line. His brigade, by staying the tide of Confederate victory, saved the day. But the struggle was not over. Bragg's entire force, excepting a part of Breckenridge's across the river, now pressed on to break the newly formed Union line. Wood, though severely wounded, with Van Cleve, fought the Confederate left under Breckenridge and repulsed his charges till darkness put an end to the conflict, leaving the Union troops, to use Rosecrans' own words in his report, "masters of the original ground on their left, and their new line advantageously posted, with open ground in front, swept at all points by their artillery."

Rosecrans' loss in men and guns had been heavy, but he was not discouraged. Bragg had sent a despatch to Richmond stating that after ten hours

fighting he "had driven the enemy from every position but his extreme left, held by Hazen, and had as trophies 4000 prisoners, 2 brigadier-generals, 31 guns, and 200 wagons and teams." What, then, must have been his astonishment to see his antagonist standing next morning, on advantageous ground and with undiminished confidence, in order of battle? This day (Jan. 1) little was attempted by either of the exhausted armies beyond skirmishing and artillery firing, and preparing for a renewal of the struggle. Van Cleve's division had during the night been thrown across Stone River and taken possession of a height commanding the upper ford. Nor had Bragg been idle during the same time, but had planted four batteries to sweep the Union lines, and with these he opened a terrific fire at 8 A. M. This was, however, quickly silenced by Bradley's guns and those of Walker's and Sheridan's divisions. There was now a lull till 3 P. M., but the Confederates were massing along Beatty's front and threatening danger there.

Rosecrans, adhering to his original plan of turning Bragg's right and capturing Murfreesboro', had strengthened Van Cleve's division by one of Palmer's brigades. While he was engaged in examining the line it was suddenly assailed by Breckenridge's entire corps with cavalry and artillery, aided by heavy enfilading fire from Gen. Leonidas Polk's artillery in the centre. The Union troops were rapidly driven in confusion across the river, closely followed by Bragg's entire right wing in three lines of battle, which came sweeping down the slopes to the edge of the stream.

But in the meantime Crittenden's artillery had been massed on the rising ground on the opposite side, to enfilade the enemy with 58 heavy guns, and these opened with fatal effect, mowing down the pursuers in lanes. A fierce battle ensued. Both sides massed their batteries; both felt that the decisive moment had come. "For a time," says an eloquent writer to whom we acknowledge our obligations, "it seemed as if mutual annihilation were to be the result." Finally Miller, and Stanley with his cavalry, charged simultaneously and drove the Confederates rapidly before them. This charge decided the day. "In 40 minutes," says Rosecrans, "the Confederates lost 2000 men, and their entire line fell back leaving 400 captive." The Battle of Murfreesboro' was over.

The 3d was occupied by Rosecrans in making preparations to follow up his victory. During the night Bragg retreated through the village in the direction of Chattanooga, leaving 2000 sick and wounded in his hospitals. The next day was Sunday, and all remained quiet. On the morning of Monday (Jan. 5th) the Confederate rear-guard was driven by Thomas 6 or 7 miles on the Manchester road and the village definitely occupied.

The loss on both sides had been heavy. That of the Union army was 1533 killed, 7245 wounded, and 3000 prisoners. Bragg claimed to have taken 6273 prisoners. His own loss he acknowledged to be 10,000, of whom 9000 were killed and wounded.

(J. H.)

STONES, BUILDING. The ordinary building materials may be divided into two classes, natural and artificial, the former comprising wood and stone, the latter brick, iron, artificial stone, etc. Of these stone is ordinarily the most expensive, but is preferred for all buildings intended to be handsome and imposing, from its beauty of texture and color and the appearance of massive solidity which it is capable of giving. It has its defects, however, many building stones being deficient in durability when exposed to the atmosphere. Some rapidly decay under the influence of the weather, particularly in damp, frosty climates, while some are seriously af-

ected by the sulphurous and other acid emanations of large cities. London is particularly destructive to building stones from these causes—materials rapidly disintegrating there which are very durable in drier and purer atmospheres. The building stones of the United States yet await thorough exploration. The first effort to collect and display the wealth and variety of these products in the several States was made at the Centennial Exhibition of 1876, on which occasion a highly useful and instructive collection was displayed. More recently the National Museum at Washington has engaged in this desirable enterprise, and has now a large and handsome cabinet of the various building stones of the country, cut into 4-inch cubes.

Building stones may be broadly divided into three classes: First, the diversified series known under the general name of granite (named in government publications crystalline silicious rocks); second, the limestones and marbles; third, the sandstones. A fourth division, of minor importance in building, includes the slates. These various rocks are obtained and prepared for market by several processes, adapted to their special characters. For the harder rocks explosives are generally used, the rough masses obtained by blasting being afterward chiselled, sawed, or otherwise worked into shape. In other cases the rocks are got out by channelling and wedging, where natural lines of cleavage render this available, while the more fragile and valuable marbles are sawn out in the quarries, so as to avoid splitting the brittle rock by the use of the blast.

Granite may be defined as a crystalline, unstratified rock, composed usually of various combinations of mica, quartz, and felspar, and, as used in building, ordinarily susceptible of a fine polish. It is whitish or grayish in hue, or mottled with a flesh-red, but is sometimes quite dark. Its expensiveness prevents its being often used for private edifices, though it is generally used in large public buildings, and is coming more and more into employment for banks and other large commercial edifices. The employment of polished granite is rapidly extending, both for columns and other ornamental additions to buildings, and for cemetery purposes, where its durability makes it much superior to marble. The coarser kinds of granite are often used for street pavements where the traffic is heavy.

Granitic building stones are very widely distributed throughout the United States, though up to the present time New England has been the most important centre of the granite-quarrying industry. The granites of that region are, taken as a whole, the finest yet developed in the country, yielding several varieties of hardness, texture, and color, many of them being very beautiful and of unusual solidity. Nearly all the massive government buildings on the Atlantic seaboard, and many of the great public buildings in Washington are constructed of New England granite, from the Quincy and other quarries.

Good building granite occurs in Virginia, North and South Carolina, Georgia, and Tennessee, while in the valley of the Colorado, Texas, is an extensive deposit closely similar to the red sienite of Egypt. The State capitol at Austin is built of this stone. In the Rocky Mountain region granite suitable for building purposes occurs abundantly, existing in great quantities in Montana and Wyoming, and less extensively in Dakota. In Colorado extensive deposits have been opened, some containing a red crystalline rock susceptible of high polish, and suitable for fine ornamental work. Other quarries yield a cream-colored stone that polishes well. In addition to the granites may be named a fine pink-colored lava, which has been largely used as a building stone in Denver. Granitic rocks are abundant on the Pacific slope, the Sierra Nevada being composed of this material

throughout. Much of this stone has been used in San Francisco for public buildings. In the Penryn quarry, near Sacramento, the granite splits so evenly that blocks 100 feet long and of almost any thickness can be readily obtained. The colors are blue, black, gray, and other varieties of hue. Oregon and Washington possess granitic building stones in equal abundance.

In close connection with the granites may be named the green serpentines, which have been used to a considerable extent in Philadelphia buildings, being obtained from quarries in the vicinity of that city. The most imposing structures in this material are the buildings of the University of Pennsylvania. In western North Carolina there is a very large deposit of serpentine, or verd antique, which is sold under the name of green marble, polishes finely, and is much used for interior decoration. This is the only extensive deposit of this stone in the Union.

The limestones suitable for building purposes comprise three classes, common limestone, gypsum, and marble, the latter varying from coarse grades, which shade into limestone, to the finest-grained marbles. Of coarse marbles the most extensive deposit yet opened lies in Westchester county, N. Y., just north of the city. This has yielded nearly all the building marble used in New York City—the university, the Roman Catholic cathedral, and other imposing buildings being constructed of it. At Lockport exist extensive beds of a compact, soft, and easily worked grayish limestone, which hardens when exposed to the air. It is a handsome stone and has been largely used, the Lenox Library building, New York, being an instance.

North Carolina comes next to New York in the possession of extensive beds of building limestone. These occur in the mountain region of the west, while on the coast "shell limestones," suitable for building purposes, abound. East Tennessee possesses an abundance of oolitic limestone, characterized by minute round grains. This is very white, of excellent quality, works easily, and wears well. In the centre of the State are limestones nearly as hard as marble, of which the State capitol at Nashville has been built. West of the Mississippi extensive beds of limestone suitable for building occur in Missouri, Iowa, Kansas, and Nebraska, while in Iowa is a bed of solid gypsum which extends for 5 miles along the Des Moines river, and has been quarried and used for building. Montana, Wyoming, and Colorado are similarly well supplied, the Jefferson Company's quarries in the latter State being practically inexhaustible. On the Pacific slope limestones exist abundantly, but not of quality well suited for building purposes.

Marbles suitable for building are quite as widely distributed. The finest quality of American marble yet discovered is that of Vermont, being a portion of a continuous belt which extends from the coarse marbles of Westchester county, N. Y., across Vermont into Canada. The finest grades occur within 30 miles north and south of Rutland, Vt., the marbles here being of fine texture and pure white color. The veins of the finer material are nowhere very large, and it being more liable, with greater purity, to crack and splinter in quarrying, it is now got out by sawing instead of blasting. Ingenious machines drive peculiarly shaped saws, often with black diamond-pointed teeth, that cut channels into the rock. The deposits are practically inexhaustible, the marble being delicate in texture, some white enough for statuary, and all polishing finely. It is largely employed for furniture and interior decorations.

The southern Alleghanias possess vast deposits of marble, of fine texture and almost every shade of color; western North Carolina having beds of white, pink, black, gray, drab, and mottled, all susceptible

of a fine polish. Opposite these, in eastern Tennessee, are extensive beds of very handsome marbles, often beautifully variegated in color. These have been used extensively for interior finish in expensive private dwellings, and largely for steps and staircase wainscoting in hotels and other large public buildings. The colored Tennessee marbles have been used in the interior decoration of the Capitol at Washington, and in the governor's room of the Albany capitol building.

In Georgia exists much the largest bed of marble yet discovered in the Union. This marble is of uniformly fine texture, the color varying from white to variegated, some of the latter varieties being of great beauty. The marble area of North Carolina, Tennessee, and Georgia is greatly the most extensive in the Union, and its material the most diversified in character. In Iowa is a peculiar deposit known as coral marble, one of its constituents being a fossil coral or sponge, which shows itself in delicate tracings on the marble when polished. It is greatly varied in hue, the foundation color being mostly gray or drab, and the beds are practically inexhaustible.

Missouri is well provided with excellent marbles, one variety known as onyx marble being extensively used for mantels, fine furniture, etc. Montana, Wyoming, and Colorado are well supplied, while Oregon and Washington have rich deposits, as yet but little developed. Undeveloped beds also exist in New Mexico and Arizona.

Yet more important than the granites and limestones for building purposes are the sandstones, which are very largely employed in the fronts of private residences. When of good quality these stones will resist the effects of heat and cold, dryness and moisture. They are used ordinarily, on account of their cost, as a sort of veneer for house-fronts, being applied in thin slabs backed up with brick. Sandstones differ very considerably in constitution, some being silicious, some granitic, others argillaceous, etc. They differ as greatly in degree of compactness and in color, the principal shades being brown, drab, and bluish. The sandstones are the most widely and generally diffused and most diverse in texture, compactness, and color of all building stones. They usually occur in deposits of moderate extent, but so numerous and scattered as to be everywhere available. East of the Alleghanias the two most important deposits are those in the valley of the Connecticut river, and near Belleville, N. Y. These beds are of immense extent, and have supplied building stones to the adjacent cities and villages for more than one-third of a century. In Ulster county, N. Y., are extensive beds of a very hard blue-stone, which is much used for steps, sills, etc., and at Potsdam a deposit of very hard and durable stone, of reddish color with veins of gray.

The Southern Atlantic States have numerous small deposits of building sandstones, while in eastern Tennessee they occur largely. The States bordering the Mississippi and Ohio are very well provided, and the same is the case with the Rocky Mountain and the Pacific slope region. The colors vary greatly, there being shades of drab and blue, blue with gray tint, pure gray, greenish-gray, white, red, and quite dark. Vast quantities of these stones are used in building.

The slate quarries of the United States chiefly exist in Pennsylvania, New York, Vermont, and Maine. The first named of these States yields more than all the others combined, its largest quarries being on the Lehigh river in the vicinity of Allentown. This slate is of fine texture, and is well adapted for roofing and other uses. The New York and Vermont deposits are continuous with each other. Their slates are of excellent quality and are employed largely to imitate variegated marbles, be-

ing, when thus treated, extensively used for wash-stands, mantels, etc. In the South, Maryland, Virginia, and Georgia have large beds of slate suitable for building purposes.

The statistics of annual production of building stones in the United States, as given in the Census report for 1880, are as follows:

	Number of quarries.	Product (cubic feet).	Product (value).
Marble and limestone	616	65,523,965	\$6,356,681
Sandstone.....	502	24,776,930	4,180,391
Crystalline silicious rocks.....	313	20,506,568	5,188,968
Slate.....	94	4,572,670	1,529,985
Total.....	1,525	115,380,133	\$18,356,055

Of sandstone-producing States Ohio stands at the head, yielding 33 per cent. of the entire product. Pennsylvania yields 25, New York 12, New Jersey 8, and the other States in rapidly diminishing ratio. Illinois, Iowa, and Pennsylvania are the leading States in quantity of limestone and marble produced; while of the granites, Massachusetts yields 25 of the total product, Connecticut and Pennsylvania 14 each. Of the slates, as we have already said, Pennsylvania is the principal producer. The above ratio of State production, however, is destined to greatly change in the coming years. Building stones of good repute have been carried long distances, though equally good stone, without reputation, lay in the immediate vicinity of the builder. The development of the resources of the country will change all this, and the several States come more and more to depend on their own deposits for home use. (C. M.)

STONES, PRECIOUS. Up to the present time the territory of the United States has by no means proved prolific in the more valuable gems, the precious stones which it possesses in any abundance being of the less esteemed kinds. And though it is quite within the limits of possibility that important deposits may yet be discovered, the probability is against it, so far as the most highly valued gems are concerned. Of precious stones within the United States over thirty varieties are enumerated, but of these none of great money-value have been discovered. In 1884 the sale of native stones brought but \$28,650, while that of foreign importations reached \$8,712,315. In 1886 the value of native stones sold was \$79,056. So far there has been no persistent search for precious stones in this country, those found being generally discovered in the process of mining for metals and useful minerals. Systematic mining for precious stones is reported from only two places: Mount Mica, Paris, Maine, which in 1886 yielded \$5,000 worth of tourmalines (cut value); and Stony Point, N. C., where in that year nine emeralds were found, valued at over \$3,000, the value of the total find being about \$4,000.

Diamonds are found in the United States in very limited quantities and of small size. They are seldom of the first water. They have been picked up in widely separated localities, but nowhere in sufficient abundance to warrant extended research. Many of the claimed diamonds, indeed, have proved on testing to be minerals of much less value. They are found in gravel-beds and alluvial soil, no diamond-bearing matrix having been discovered. The find of 1884 was valued at \$800 only, and in it the most beautiful stone was worth but \$100, the others being generally colored. Itacolumite, or "flexible sandstone," which is looked upon as a matrix of the diamond, occurs in the Carolinas and Georgia, and many small stones have been found in its vicinity. The largest native diamond yet found was dug up in 1884 by a laborer at Manchester, Va. Its original

weight was 23½ carats, but cutting reduced it to 11½ carats. It was held at an extravagant value, and \$1500 expended on its cutting, yet it is not considered by experts as worth more than \$300 or \$400, it being off-colored and imperfect. Diamonds have been found in North Carolina, Georgia, Indiana, Oregon, and other States; also in the gravels or gold-washings of California and Nevada, but there is no clew to their place of origin. Of late years there have been observed in Kentucky and Tennessee deposits of peridotite in association with carbonaceous shales. This is exactly the condition existing at the Kimberley diamond mines, South Africa, and several geologists are of the opinion that the American peridotite may yet yield diamonds. But it has not yet done so, and the promise is not good.

Emeralds and beryls—stones which are similar in composition but differ in their coloring substance—have been found in small quantities. They are most abundant in North Carolina, but have also been found in Maine, Massachusetts, Connecticut, and Pennsylvania. Many beryls, yellow, green, and white in color, have been picked up in recent years in Litchfield county, Conn. The 1886 find of that locality, when cut, brought \$5,000. An interesting and valuable stone, allied to the emerald, was discovered in 1881 in Alexander county, N. C., as yet its only known locality. It is the only gem peculiar to the United States, and has been named Hiddenite, from W. E. Hidden, its discoverer. While, like emerald, a silicate of alumina, it differs in having lithia for its base. It occurs in slender crystals, resembling emerald only in color, and is found in nests or pockets, often associated with emerald and beryl. Its rarity and beauty have caused it to be greatly in demand, as yet largely for cabinet purposes.

Sapphires and rubies have been found in New Jersey and North Carolina. Macon county, of the latter State, has yielded them of various shades of color, blue, red, yellow, and colorless. In 1872 the Jenks mine, near Franklin, N. C., yielded a sapphire crystal, of 312 lbs. weight, which is now in the Amherst College mineral cabinet. In the west they are found in New Mexico, Colorado, Arizona, and Montana. Mount Helena, Montana, is the richest locality for sapphires in the United States. Topazes are found in Maine, New Mexico, Colorado, Utah, and Arizona. Pike's Peak, Colorado, has yielded some fine light-blue specimens, considered equal to those of the same size from Siberia. The Utah specimens are small, and generally of a limpid white color. Beautiful fire opals have been found in Georgia and North Carolina, but none possessed of opaline iridescence. Coarser grades occur in Lebanon county, Pa. In many places of the West opals occur with some play of color. Garnets are widely distributed, and crystals suitable for gems or watch-jewels abound in Colorado. Agates are found in many places along the Connecticut river, in southeastern Pennsylvania, and in North Carolina. They abound around Lake Superior and in the upper Mississippi region, while the Rocky Mountains and California yield beautiful specimens. The favorite variety known as moss-agate is found in Pennsylvania and North Carolina, and is abundant in Humboldt county, Nevada.

Amethysts occur in many localities in New England, in Delaware county, Pa., in Georgia, and in many places west. The Lake Superior variety is coated like the moss-agate. In Yellowstone Park they are found as a beautiful lining to the interior of hollow, petrified, or silicated trees. In color they are usually of light purple bordering on pink, and as gems are of little value. Tourmaline is found in Maine, New York, and Pennsylvania. The richest finds are in the Maine locality above-mentioned, the crystals being usually colorless, but

often of varying shades of pink, blue, yellow, and green. The two largest found in 1886 were of a rich grass-green color, and weighed respectively 34½ and 27¼ carats.

The stone known as serpentine has a translucent variety of a rich, oil-green color, varying from dark to pale. This is called precious serpentine and is used for ornaments. It is found from Maine to Maryland, and abounds in North Carolina, but not of fine quality. The finest grades come from near Newburyport, Mass. Malachite, suitable for ornament, occurs in very small quantities, though the Copper Queen mine, of Arizona, has yielded this mineral in large masses. Turquoise has been found of late years in New York, Arizona, and Nevada. It is not highly valued as a gem. The same may be said of jasper, which is found in many localities. North Carolina yields it of the texture known as cat's-eye. Jade has been obtained from the Indians of Alaska, but its locality is not known.

Chalcedony is obtained, of a pink color, from near Cisco, Utah. It takes a fine polish, but has been little introduced as yet. Jet, a variety of lignite or mineral coal, of value for mourning ornaments, is found abundantly in the California lignites. Amazon stone, a green felspar from Pike's Peak, is used slightly as a gem. Obsidian occurs largely in Yellowstone Park. Some of it is beautifully colored, and it may yet prove very useful in the ornamental arts. Jasperized, or so-called petrified wood, also abounds in the same locality and in Arizona. In this the wood-tissue has been replaced by silica. It polishes well, and is sold as an ornamental stone.

Of other minerals used for gems may be mentioned sunstone and moonstone, found only in Delaware county, Pa., and near Orange Court-House, Va.; spinel, occasionally found of fine quality; aquamarine, from several localities; phenakite, found at Pike's Peak, of fair size and fine quality; rock crystal (quartz), of which limpid specimens are often cut for gems; smoky quartz, which is cut as a gem to a considerable extent; and gold quartz, which, when clear and well penetrated by gold, makes a handsome stone. There are many other minerals which are occasionally cut and used as ornamental stones, but the above-named are the most important. (C. M.)

STORER, BELLAMY (1798-1875), jurist, was born at Portland, Maine, March 9, 1798. He graduated at Bowdoin College, studied law in Cincinnati, and was admitted to its bar in 1817. As editor of the *Crisis*, a Federal party-organ, he advocated in 1824 the election of John Quincy Adams as President. In 1835-37 he was a representative in Congress, and in 1844 a presidential elector in favor of Henry Clay. He occupied for many years a chair in the law school of Cincinnati, and was for 14 years a judge of the supreme court of Ohio. His religious feelings were warm. In his youth he was a leader in a band of young men who, under the name of "flying artillery," went from place to place promoting revivals. In 1821 his *alma mater* conferred on him the degree of LL. D. He died at Cincinnati, June 1, 1875, holding at the time the office of vice-president of the Evangelical Alliance.

His brother, DAVID HUMPHREYS STORER, physician, was born at Portland, March 26, 1804, and graduated at Bowdoin College in 1822. In 1825 he received the degree of M. D. from Harvard, and forthwith commenced practice in Boston, where he originated the Tremont Medical School. In 1854 he was appointed professor of obstetrics and medical jurisprudence in the Harvard Medical School, and was subsequently dean of that school. In 1876 the degree of LL. D. was conferred on him by Bowdoin. Dr. Storer for several years was physician to the Massachusetts General Hospital, he had charge of the

departments of zoology and herpetology in the Massachusetts State survey, and in 1866 was president of the American Medical Association. Among his productions are, *Synopsis of the Fishes of North America* (Cambridge, 1846); *History of the Fishes of Massachusetts* (Boston, 1853-67).

His son, HORATIO ROBINSON STORER, surgeon, was born in Boston, Feb. 27, 1830. He graduated at Harvard, 1850, where he devoted himself mainly to the natural sciences. Thenceforward he studied medicine, receiving his degree in 1853. He spent the next two years in the great schools of Europe, acting for a year as private assistant to Sir James Y. Simpson, of Edinburgh. In 1855 he began practice in Boston, taking for his specialty midwifery and the diseases of women. From 1865 to 1869 he occupied the chair of obstetrics and medical jurisprudence in Berkshire Medical College. To qualify himself more perfectly for teaching medical jurisprudence, he returned to Harvard to attend its law school, and graduated from it in 1868. His lectures to medical students on the diseases of women were attended by physicians from all parts of the country. In 1872 he returned to Europe, spending five years there, mainly in Southern Italy, in the study of the fevers of that district. On his return to the United States he settled at Newport, R. I., where he still resides. Dr. Storer was instrumental in founding the Boston Gynecological Society, of which he was for some time president, acting also as editor of its journal. In 1865 he was secretary and prize-essayist of the American Medical Association, and its vice-president in 1866. He has been an exceptionally prolific writer on medical subjects, both in professional journals and in book-form. In the latter shape he has published *Why not? A Book for Every Woman*, which received the gold medal of the American Medical Association (Boston, 1866); *Is it I? A Book for Every Man* (1867); in conjunction with F. F. Heard, *Criminal Abortion; its Nature, its Evidence, and its Law* (1868); *On Nurses and Nursing*, (1868); and *Southern Italy as a Health Station* (1875).

His brother, FRANCIS HUMPHREYS STORER, born in Boston, March 27, 1832, studied also in Harvard Scientific School, devoting himself specially to chemistry under Prof. Josiah P. Cooke. In 1853 he was appointed chemist to the Pacific exploring expedition, and on his return completed his scientific course at Harvard, and graduated, 1855. After further study, in Europe, he devoted himself to teaching chemistry and to the practice of his profession as an analytical chemist, in which latter capacity he held several appointments. In 1870 he was appointed professor of agricultural chemistry in Harvard, a position he still holds, while he is, at the same time, dean of the Bussey Institution. He has been a constant contributor to scientific periodicals, and was for a time American editor of the *Repertoire de Chimie appliquée*. In book-form he published, with Charles W. Eliot (now president of Harvard University), *Manual of Inorganic Chemistry* (1868) and *Manual of Qualitative Chemistry Analysis* (1869); *Cyclopaedia of Qualitative Analysis* (1870-73); and *Agriculture in Some of its Relations with Chemistry* (2 vols., 1887).

STORMS. See TORNADO.

STORRS, RICHARD SALTER, Congregationalist pastor and author, was born at Braintree, Mass., Aug. 21, 1821. He graduated at Amherst College in 1839, and entered on the study of law under Rufus Choate, but then turned to theology. He graduated at Andover Seminary in 1845, and became pastor of a church at Brookline, Mass. A year later he was called to take charge of the newly organized Church of the Pilgrims at Brooklyn, N. Y., and has since continued in that position. From 1848 to 1861 he was one of the editors of the *Independent*. He is noted for his eloquence and is an advocate of preach-

ing without notes. He has published *Constitution of the Human Soul* (1857); *Early American Spirit* (1875); *John Wycliffe and the First English Bible* (1880); *Recognition of the Supernatural* (1881); *Manliness in the Scholar* (1883); *Divine Origin of Christianity* (1884).

STORY, WILLIAM WETMORE, sculptor, was born in Salem, Mass., Feb. 12, 1819, and was graduated at Harvard in 1838. He was the son of the renowned jurist, Joseph Story (for whom, see *ENCYCLOPEDIA BRITANNICA*). Law first claimed the son's attention also; he was admitted to the bar, and became known as the author of treatises on the *Law of Contracts* (1844) and *Law of Sales* (1847), and other legal tomes. But he also contributed to various periodicals, delivered poems on several occasions, in 1847 brought out his first volume of poems, and in 1851 published *The Life and Letters of Joseph Story* (2 vols.). The direction in which his tastes lay had already been indicated in some of his writings, and in 1848 he went to Italy, where he has since devoted himself chiefly to art. He has modelled portrait-statues of his father, Edward Everett, and George Peabody; busts of Theodore Parker, Josiah Quincy, and James Russell Lowell; and a number of ideal works, among them Sappho, Saul, Cleopatra, Delilah, Helen, Jerusalem in her Desolation, Semiramis, Judith, Sardanapalus, and Thetis and Achilles. Some critics have seen talent rather than genius in these thoughtful, carefully executed works, but, though not strikingly original, they are noble and pure in sentiment, the products of a highly cultivated mind. In Europe he has been regarded by many as the foremost among American sculptors. As an author he is almost equally well known, and has published *Roba di Roma*, sketches of Italian life, *Proportions of the Human Figure*, and various volumes of poems, including *Gruffiti d'Italia* and *The Roman Lawyer in Jerusalem*. (F. L. W.)

STOUGHTON, JOHN, English Congregationalist author, was born at Norwich, Nov. 15, 1807. He was educated at Highbury and University Colleges, London, and became pastor at Windsor in 1832, and at Kensington in 1843. He was chairman of the Congregational Union in 1856, and became professor of historical theology and homiletics in New College, St. John's Wood, London, in 1872. He resigned this post in 1884, having resigned his pastorate also in 1875, when he received a testimonial of £3000. He was a delegate to the conferences of the Evangelical Alliance at New York in 1873 and at Basel in 1879. He has been active with his pen and has published many books relating to English church history. Among them are *Church and State 200 Years Ago* (1862); *Ecclesiastical History of England* (6 vols., 1867-81); *Religion in England, 1800-1850* (1884). Among his popular biographical works are *Philip Doddridge* (1851); *Haunts and Homes of Martin Luther* (1875); *Worthies of Science* (1879); *William Wilberforce* (1880); *William Penn* (1882); *John Howard* (1884); *Italian Reformers* (1881); *Spanish Reformers* (1883).

STOVES. Several localities have laid claim to the first manufacture of stoves in the United States. In 1741 Benjamin Franklin invented what he called a "Pennsylvania fireplace," consisting of several plates of cast iron with a "shutter" to regulate the draught and a "register" to distribute the heat properly. In 1744 Franklin printed, from his own press, a description of the Pennsylvania fireplace. The book begins by stating that in the Northern colonies fires were necessary seven or eight months in the year; and that wood was becoming scarce, and even then had to be carried as much as 100 miles before it was used. Therefore the writer had invented the Pennsylvania fireplace in order to save something of the large quantities of wood that went to waste in the generous fireplaces of those days. There were then

in use in the colonies, to a very limited degree, Holland stoves with doors opening into the room and with a flue from the top. The German stoves, also in use, had doors upon the outside of the building or in some other room. While they gave a good heat yet there was the objection that the fire could not be seen. In addition to Holland and German stoves there was a limited use of charcoal fires in pots for the heating of chambers; but with the great objection that the gases generated often proved dangerous. Franklin's stove was a great improvement on all that had preceded it. The principle of its action was the same as that of the air-tight stoves introduced many years later. Indeed, it would have been air-tight had it been possible at that time to make the castings sufficiently close-fitting. Almost at the same time that Dr. Franklin wrote, John Potts made stoves at Pottstown, Pa.; but no description of these is given. There are stoves in existence to-day, bearing the date 1756, and manufactured by J. Glominger & Co., at Huntingdon Springs, Pa. The plates are nearly one inch thick. About 1757 Henry William Stiegel (known as Baron Stiegel) came to Lancaster County, Pa., and built the Elizabeth furnace in the town of Mannheim. He also built a furnace and a fortified place in Lebanon County, where he cast the six-plate stoves which were among the first of the kind in the country. He was rapidly developing his industry when the war of the American Revolution made it impossible for him to meet his liabilities. In 1767 William Lyle, of New York City, made the first hot-air furnace. It consisted of heavy plates about 30 inches square on the side. From 1770 to 1775 Franklin also invented several other stoves, among them two or three for the burning of bituminous coal. One of these had a downward draught, and consumed its own smoke; the other had a basket grate or cage, with movable bars at the top and bottom, which, after being filled and kindled at the top, could be inverted, and so made to burn at the base.

Between 1785 and 1795 Benjamin Thompson, known as Count Rumford (see THOMPSON, in the *ENCYCLOPEDIA BRITANNICA*), devised several improvements in stoves, ovens, etc., all intended to economize fuel and heat. Soon after the Revolutionary war George Youle established a stove store in Water Street, New York, where he made galleries for the navy. In 1812 Charles Postly made a nine-plate stove of an oval shape with the fire directly under the oven and with openings on the sides in which tubular boilers were placed.

Previous to 1825 the use of stoves, generally of the box pattern, and of a very rude construction, was confined to stores, hotel bar-rooms, school-houses, and churches in the cities and larger towns. In these churches the stoves were sometimes raised on stilts that the people in the galleries might be warmed. Country churches were not usually heated, but the older women carried their foot-stoves and the men protected their feet with stout leather overshoes, known as "boxes." In the residences of some of the more wealthy city families cannel and other English coal, generally referred to at the time as "sea-coal," was burned in imported grates or in Rumford stoves, lined with fire-brick. A large number used the Franklin stove as an open fireplace, burning wood in it. A still greater number used the capacious, old-fashioned fireplace. The cheapness of fuel, the cheerfulness of an open fireplace, and the great weight and rough construction of the stoves of those days, made the latter in but little demand. After the opening of the Erie and Champlain canals, the introduction of river steam-boats, and the beginning of railroad travel, the facilities for transporting heavy goods were so much increased that the manufacture of stoves soon became a leading industry.

These were wood-stoves, but anthracite coal, which was gradually coming into use wherever a high degree of heat was required and a strong draught possible, was destined to create a revolution in the business.

Anthracite coal came into use about the year 1820, when but 365 tons were sent to the market. A new kind of stove was required for anthracite, in which the draft of air would be much smaller. One of the earliest in this field of invention was Dr. Eliphalet Nott, who spent several years in perfecting his inventions for heating. The chapel of Union College was heated by one of his stoves, in which the base-burning principle was used. There was also a marvellous kind of box stove, which was attributed to the genius of Dr. Nott. The iron was about an inch thick and could be neither broken nor bent. Dr. Nott, however, did not have the first patent on anthracite stoves. His was the third, it being issued in 1832. The first patent went to Anthony Savage, of Pottsville, Pa., in 1830; and the second to Jordan L. Mott, of New York, in 1832. The latter showed that the anthracite fire could be made from nut- and pea-sized coal, and established several other facts concerning the laws of combustion, so that anthracite coal stoves became salable.

From their position at the foot of the Erie Canal, and at the head of navigation on the Hudson River, the cities of Albany and Troy early became great centres of the stove industry. Fortunately for them both, the best moulding sand in the country was close at hand. The first cooking stoves manufactured in these cities were of the old ten-plate oval pattern, the oven above the fire. About the year 1860 the question of burning anthracite coal from the bottom of the magazine within the stove was widely discussed, but it was found that Littlefield, of Lowell, had in 1852 patented a base-burner covering the chief points that the inventors of 1860, and later, had attempted to cover. From that time the use of base-burners has increased in a marvellous degree.

What are known as gas stoves are simply enlargements or adaptations of gas-burners to the process of heating. Vapor stoves were invented about 1863 as a means of vaporizing the products of petroleum. They are, practically, nothing more than large lamps adapted to other purposes than lighting.

Stove Factories.—A description is given of a leading factory in the city of Albany. The ground consists of about 5½ acres, the establishment being one of the largest in the country, having a capacity of about 500 hands, whose skilled labor is capable of making from 100 to 200 stoves a day of every description, from the mammoth hotel-ranges and heaters to the oil and vapor stoves, including parlor and cook stoves, furnaces, ranges, together with stove fixtures of every possible style. The main building, in which are contained the general and manufacturing offices, show-room, mounting, repair, shipping, nickel-plating, oil stove, and general storage departments, is 200 × 71 feet, 4 stories in height, with a basement, and is built of brick. This building is supplied with two large elevators capable of sustaining any desired weight. In the pattern-makers' department every pattern, constructed from the best of soft woods, is formed almost entirely by hand. Here some of the most skilled workmen are to be found, since much depends on the pattern as to the success of the casting. In the nickel-plating room the different pieces of the stove undergo the nickeling process, after which they are removed to a room adjoining, and burnished on emery and felt wheels. Near the main structure is a building, 50 × 50 feet, constructed of brick and 2 stories high, that is used for the casting and cleaning departments on the first floor, and a tin shop on the second. The buildings adjoining this contain the engines and

boilers. One of the former has a capacity of 250 horse-power and the other of 50. The latter engine is used principally to run the dynamo that furnishes electricity for lighting purposes. The boilers are sufficient to furnish enough steam to supply both engines and also heat the several departments thoroughly in the most severe weather. The jupanning department, fitted with all the modern appliances for the successful prosecution of this work, adjoins the main building on the south. A building, 100 × 24 feet, 2 stories high, also constructed of brick, adjoins the scratch shop. This contains the facing room, ladle oven, blacksmith and carpenter shops on the first floor, while on the second floor are the iron and wood pattern shops, the latter being located at the southwest corner of the building. Every pattern is made from drawings supplied by draughtsmen regularly employed for this purpose. The work is almost entirely executed by hand, entailing a heavy expense and the consumption of considerable time. It is necessary that the greatest care should be used in the manufacture of the patterns, as the least flaw can easily be detected in the castings. A fourth building, 90 × 30 feet and 3 stories high, stands west of the main structure on the north line. This is used principally for the storage of coal and wood and general supplies. Adjoining this is a three-story brick structure, 20 × 23 feet, which is also used for general storage on the first floor, while the two upper apartments are given over to the use of the employes. At the west of these buildings is a huge structure, 130 × 281 feet, known as the moulding department. It is built of wood filled in with brick, and has a gravel roof. This building contains 150 "floors," a technical term applied to that section of a moulding room where flasks are repaired. Centrally located on the east line of this building are three cupolas for melting the iron, which is done by blasts supplied by two "blowers" that are located in the engine-room. The 250-horse-power engine used to drive the blasts is of low pressure, perfectly reliable, and capable of doing the work required of it. These cupolas have a capacity of about 20 tons of melted iron per day. Located midway between the moulding and scratch-shop buildings is the mill room, wherein are several "mills" that are revolved continuously for the purpose of "milling" or removing the spraws and chuders from the castings. West of the moulding shop is a building, 12 × 36 feet, containing the moulding and other sands used in the manufacture of stoves. There are also some dwellings and stables on the extensive grounds. While the buildings themselves do not cover fully five acres, the land not covered with buildings is devoted to the storage of lumber, pig-iron, flasks, etc. The buildings are perfectly adapted to the use for which they are intended. Each department is heated by steam and lighted by electricity; for the former, iron pipes run about the several buildings and the steam is supplied from the mammoth boilers adjoining the engine-room. The buildings may be considered practically fire-proof; automatic sprinklers are attached to water-pipes that are fastened to the ceilings of the several apartments. These sprinklers are at a distance of 8 feet apart, and the pipes are always kept filled with water. In the event of any apartment being on fire the heat will melt the solder, thus allowing a cap to drop down and the water to spurt into the burning room. The water thus released covers a distance of 8 feet in either direction. The moment the water in the pipes is released, it removes the pressure upon a large tank containing about 9000 gallons of water, and the automatic pump is immediately set in motion and renews the water-supply. Every department is supplied with the automatic sprinklers except the

moulding shop, which has seven hydrants, with 450 feet of hose always attached for immediate use. The force of water from the hydrants is sufficient to throw two 4-inch streams over any of the buildings. These hydrants are so constructed as to be quickly reached and used to advantage from either the inside or outside of the moulding shop. The works, when in full working order, have a capacity of from 100 to 200 stoves a day.

The chief centres of the stove-making industry in the United States, aside from Albany and Troy, already noted, are Boston, Cincinnati, Philadelphia, Buffalo, Louisville, St. Louis, Cleveland, Pittsburgh, Detroit, Chicago, and Kansas City.

(F. G. M.)

STOWE, CALVIN ELLIS (1802-1886), clergyman, was born at Natick, Mass., April 26, 1802. He graduated at Bowdoin College in 1824 and at Andover Seminary in 1828, then becoming a teacher there. In 1831 he was made professor of Greek and Latin in Dartmouth College, and in 1833 accepted a call to be professor of biblical literature in Lane Theological Seminary at Cincinnati. While there he married in 1836 Miss Harriet Beecher, whose career has been sketched in Vol. I. in connection with the Beecher family. In 1850 her husband went to Bowdoin College as professor of natural and revealed religion, and in 1852, just as her remarkable work, *Uncle Tom's Cabin*, was becoming known, he was made professor of sacred literature in Andover Seminary. He discharged the duties of this position until 1864, when he retired. He died, Aug. 22, 1886. At the beginning of his career he translated, with additions, Jahn's *Hebrew Commonwealth* (1828), and Lowth's *Lectures on Hebrew Poetry* (1829). He afterward published a report on *Elementary Public Instruction in Europe* (1838), and some other works on education. After retiring from his professorship his lectures were summarized in his *Origin and History of the Books of the Bible* (1867).

STRAIN, ISAAC G. (1821-1857), naval officer and explorer, was born at Roxbury, Pa., March 4, 1821. In 1837 he entered the navy as midshipman. In 1845 he led a small exploring expedition into the interior of Brazil, and in 1848 he made a personal exploration of Lower California. In 1849 he crossed South America from Valparaiso to Rio Janeiro, and published an account of his journey under the title, *The Cordillera and Pampa* (1853). In 1850 he was promoted lieutenant and was attached to the commission that determined the boundary-line between the United States and Mexico. Afterward he commanded an expedition to explore a line for a canal across the Isthmus of Panama. The party suffered extreme hardships, losing several of its members, and the heroism Strain displayed first attracted public attention to him. An account of the expedition, compiled by J. T. Headley, appeared in *Harper's Magazine* in 1856. In 1856, sailing in the Arctic in the North Atlantic, Strain ascertained by soundings the practicability of a telegraphic cable between the United States and Great Britain. His death, due to exposure on the isthmus, occurred at Aspinwall, May 15, 1857. Among his interesting papers communicated to the American Geographical Society was one on *The History and Prospects of Interoceanic Communication* (1856).

STRAWBERRY, a plant of the order *Rosaceæ*, genus *Fragaria*, which bears one of the most delicious of our small fruits, and is widely cultivated throughout all civilized lands. The name is of Anglo-Saxon derivation, and probably comes from the wandering habit of the plant, being a corruption of *stræ*. The strawberry-plant is a stemless, perennial herb, with compound leaves of three coarsely serrated leaflets. It multiplies by runners, or un-

derground branches, which form buds and develop roots and leaves, the runner then losing its connection with the parent plant by decaying, so that the new plant becomes independent. The flowers are 5-petalled, mostly white, with numerous stamens and simple pistils. They are seated on a convex receptacle which greatly enlarges in the fruiting season, and becomes pulpy and edible. This swollen receptacle, which is popularly considered the fruit, is really only the end of the flower-stem, greatly altered, and bearing the real fruit in the ripened ovaries scattered over its surface, or sunk in little depressions in the succulent mass.

The strawberry is found in all parts of the northern temperate zone and in the mountains of South America, and has several species native to the United States. Of these the best known is *Fragaria Virginiana*, the Virginian or common wild strawberry, which extends from the arctic regions to Florida, and from the Atlantic to the Rocky Mountains. In this species the leaves are rather long and sharply serrate, of a light-green color, the fruit mostly globular and bright-red in color, with deep pits on its surface, in which the seeds are sunk. There are many varieties of this species, and it has been described under various names. The cultivated varieties are mostly derived from this species and *F. vesca*, the Alpine or wood strawberry, the common European species, but indigenous also in the northern portions of America, where it extends from the Atlantic to the Pacific. This species bears rather small flowers, and thin, pale-green leaves, the flower-stalks longer than the leaves. The fruit is small and sweet, parting freely from the calyx, while the seeds are attached to the surface, and not sunk as in *F. Virginiana*. This was the first species to be cultivated, there being records of its culture in England more than 400 years ago. Of other American species the most important is *F. Chilensis*, the Chili strawberry. It is found on the Pacific coast from Oregon southward, and bears very hairy, thick leaflets, with large yellowish-white or rose-colored flowers, and a fruit sometimes as large as a small hen's egg. It is of a pale color and insipid taste, but has yielded valuable varieties by hybridization. The Indian species, *F. Indica*, from upper India, is naturalized in the Southern States. It differs greatly from the other species, and bears showy yellow flowers which give it value as an ornamental plant; but its fruit is dry and tasteless.

By the abortion of the stamens some species of the strawberry are rendered more or less dioecious, and modern culturists divide the varieties into two classes, the staminate or male, and the pistillate or female. In the latter the stamens are aborted and bear little or no pollen, while the former have usually a small number of pistils. The greatest bearers are

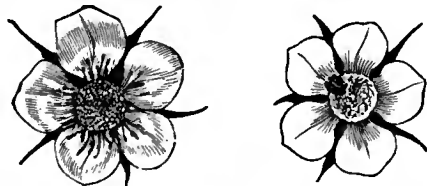

Strawberry.
Perfect Flower. Pistillate.

mostly of the pistillate variety, but they, being nearly incapable of self-fertilization, are fertilized by planting staminate plants near them. The difference can be readily distinguished when the plants are in blossom, and in selecting plants for this purpose it is necessary to choose varieties that flower about the same time. The present tendency of growers, however, is to discard the unisexual kinds. As regards

the cultivation of the strawberry the same general rules as to soil, drainage, manuring, etc., apply as in the case of other small fruits and vegetables. It needs a good, deep, rich soil, and clean cultivation between the rows, with a renewal of the plants as often as once in three years. They are planted in rows about a foot apart, the rows needing to be kept clear of runners as well as weeds. The plants are set a foot apart in the rows. They are raised from the well-budded runners of the preceding autumn, set out in early spring, or by transplanting in June after the fruit has been gathered, though early autumn is not too late for this work. In the far north the plants are often covered with hay or straw for protection from frost, they growing through the straw, which serves to keep the fruit clean.

There are a great many varieties cultivated, the first important step in this direction in the American culture being in the appearance of Hovey's Seedling. This has not been excelled in quality. The next important variety was Wilson's Albany. To these have been added many favorite varieties. The strawberry, if cultivated with care and close attention to weeding, is a profitable crop. The fruit rarely sells at a less average than 88 per hundred quarts, while careful cultivation will give at least 5000 quarts per acre, so that the crop, even at the lowest average rates, is fairly profitable. The strawberry season, formerly very brief, has now been greatly extended by the transportation of the fruit from long distances, the Northern market being supplied at first from Georgia, and then from States up the coast to New Jersey, which furnishes the principal supply to New York and Philadelphia. Later in the season the fruit from Connecticut and Massachusetts comes into market, so that the annual supply of this favorite fruit, once confined to two or three weeks, is now extended over as many months. (c. m.)

STREATOR, a city of Illinois, is on the Vermilion river in the southern part of La Salle county, 90 miles S. W. of Chicago. It is at the junction of the Chicago, Burlington and Quincy, the Wabash, and four other railroads. In the vicinity are 22 bituminous coal mines, whose annual output is over 1,200,000 tons. There are also large works, manufacturing plate and window glass and bottles, 4 tile factories, 3 foundries, railroad and machine shops, a paper-mill, flouring and planing mills, and coke works. Streator has 2 national banks, 1 private bank, 5 weekly and 3 daily newspapers, 16 churches, a commercial college, high school, and other public schools. The city, picturesquely situated on a high bluff, has gas, electric light, water-works, etc. Its property is valued at \$6,000,000; its public expenses in 1887 were \$65,000, and it has no debt. It was first settled in 1856 and incorporated in 1881, having then a population of 5157.

STREET, ALFRED BILLINGS (1811-1881), author, was born at Poughkeepsie, N. Y., Dec. 18, 1811. He received his education at Dutchess Academy, and afterward studied law under his father, commencing practice in Albany. In 1839 he removed to Albany and, after editing a newspaper for two years, was in 1848 appointed State librarian, which position he held till his death. From his youth up he contributed largely—chiefly poetical pieces—to magazines, some of his productions receiving high commendation from critics, and several being translated into German. His published poetical works comprise: *The Burning of Schenectady* (1842); *Dracings and Tintings* (1844); *Fugitive Poems* (1846); *Frontenac* (1849). His prose works are: *Woods and Waters, or the Savanacs and the Racket* (1860); *A Digest of Taxation in the United States* (1863); and *The Indian Pass* (1869). Collected editions of his poems appeared in 1847 and in 1866. He died at Albany, N. Y., June 2, 1881.

STREET RAILROADS are an institution peculiarly American, both in original conception and in development. The first horse-car for service in the streets of any city was built in 1831. This

car consisted of three compartments, each compartment holding ten persons, and being entered by separate doors on the side from a guard-rail. Seats were provided on top of the car for 30 or more persons. The car was very much like the English railroad coach, though it was set considerably lower. It was hauled by a team of horses, the conductor remaining outside on the rail. It was built for the New York & Harlem Road, which ran from Prince Street, on the Bowery, in New York City, along the line of the present Fourth Avenue (not then opened, though surveyed in 1810) to Yorkville and Harlem. The fare paid varied with the distance, being sixpence (or 6½ cents in Spanish silver currency then in vogue) from Prince Street to 14th Street, and increasing by sixpence for other distances until it was 25 cents to Harlem. In time through fare was reduced to 18 pence, and then to 12, but the road did not succeed. In 1837, after six years of continuance, it temporarily gave way to steam-cars. In 1845, however, it resumed working under its charter, which had not been given up, and which is still used for the present Fourth Avenue horse-car line. The cars were then remodelled nearly to their present style, by the adoption of end platforms and entrances. Similar cars ran in Philadelphia from the centre of the city to Gray's Ferry, on tracks used chiefly for a freight railroad. No other horse-car line was built in New York till 1852, when at about the same time charters were granted for the Second, Third, Sixth, and Eighth Avenue lines. Boston was the next American city to adopt the new system, in 1856, and Philadelphia followed in 1857, after which it spread over the country. New Orleans, in 1861, was the first to adopt the small car, or, as it is called, the "bobtail" car. In 1860 George Francis Train started a "tram-way" in Birkenhead, opposite Liverpool, England. Popular feeling was against the idea, and the company did not declare a dividend in 20 years. So intense was the popular prejudice in England at that time, that the starting of a horse-car in London caused a riot, and the rails were torn up. Nor could an act of Parliament be obtained until as late as 1870 for the construction of other roads. Now lines are operated in the American style in most of the principal cities in Great Britain, the cars, by their combination of lightness, durability, and comfort, having won the day against English manufacturers. In 1866 the countries of South America took up street-railroad enterprises on a large scale, Brazil, Venezuela, Chili, Peru, Uruguay, Ecuador, and the Argentine Republic, as well as Costa Rica, all adopting them. Cars manufactured in the United States are now sent to all civilized countries—to New Zealand, Australia, Java, India, Japan, South Africa, as well as to Canada, France, Belgium, Portugal, Austria, Holland, Germany, Russia, Sweden, Norway, and England. The chief centres in the United States for the manufacture of horse-cars are Philadelphia, New York, Troy, and St. Louis. The English cars differ from American cars in having winding stairs at each end, by which to reach the seats on top of the cars. The fares in England and in most European countries are so much a mile. In Paris the cars are allowed to carry only a certain number of passengers—10 standing on the front platform, 10 on the rear platform, and as many in the car as are allowed to have seats. Those inside pay 50 centimes (10 cents), and those outside 25 centimes. When a car has its complement the gates are shut, a sign is hung out reading, "Complet," and no one can enter. During the busy time

of the day, between 5 and 6 o'clock, when crowds are waiting for a car, it is necessary to apply at the office for a numbered ticket. The holder of a number is obliged to wait until it is called by the driver: a plan which causes inconvenience until the holder has gained his seat, but afterward it enables him to take the trip much more comfortably than the custom of crowding which prevails in America.

When street railways were first introduced, one of the most serious problems of construction was that relating to the shape of the rail. For railroads running through the country the T-rail answered every purpose, and nothing for such use has been found to supersede it to this day. But it was necessary to lay such tracks in cities that ordinary vehicles, running along or across them, should meet with as little obstruction as possible. The old Philadelphia pattern of street rail was first used for this purpose, and many tracks of this kind are still in existence. This is known as the "side-bearing" rail. During a few years past the "centre-bearing" rail has come into general use. The latter, after being worn down, has the advantage of being able to be reversed so as to present a fresh rounded edge upon which the wheel may take hold. The crown projects above the brim, or the level of the pavement, from 1 to 1½ inch. All the railroads in the United States are now using steel rails, as they are cheaper as well as better than the iron rails formerly used, but no longer manufactured in this country. The steel rails used here are all of American manufacture. The duty on imported steel rails is \$17 a ton, and ordinary American steel rails can be purchased for \$29 a ton, which is just \$1 more than the duty before the reduction of the tariff went into effect. The "life" of a steel rail is from 10 to 20 years, according to the nature and amount of the traffic.

Efforts have been made in the legislatures of several States to remove the bobtail cars, in which the passengers are obliged to discharge some of the duties of conductors. The extra work of the drivers in seeing that passengers pay their fares is the cause of frequent accidents in large cities.

It is considered that some motive power other than horses must be substituted in all of the cities; but it cannot be determined yet what that power is.

Improvements in motors are in progress; and in many of the cities the cable is superseding the use of horses. (See ENCYCLOPEDIA BRITANNICA.) Experiments are in progress with electricity as a motive power; and some of them have proved successful. A line of street railroad in the city of Binghamton, N. Y., is carried on by a "traveller" which runs on a wire suspended above the track. The traveller follows the car, and makes the electric circuit complete with a wire that parallels one of the tracks.

Motive power from storage batteries has also been tried. (See TRACTION, ELECTRIC, in ENCYCLOPEDIA BRITANNICA.)

The largest electric railroad in operation in the United States is at Montgomery, Ala. It is 13 miles long, has 18 cars, and the steam-power costs \$14 per day, or an average of from 75 to 80 cents per car. Other roads operated are as follows: Windsor, Canada, 2 miles, 2 cars, with steam power at \$4 a day; Detroit, 2 miles, 8 cars, steam, \$6 per day; Appleton, Wis., 5 miles, 5 cars, water-power, \$4.50 per day; Port Huron, Mich., 5 miles, 5 cars, natural gas, \$3.50 per day; Scranton, Pa., 4½ miles, 7 cars, coal culm or dust, \$7 a day; Lima, Ohio, 4 miles, 6 cars, crude oil, \$4 per day; St. Catharines, Ontario, 6 miles, 6 cars, water-power, \$4 per day. Electric motors are soon to be used, as follows: Jamaica, N. Y., 6 miles, 10 cars; Omaha, 7 miles, 10 cars; Dayton, Ohio, 6 miles, 12 cars; Ansonia, Conn., 3½ miles, 4 cars. It is said that the cost of maintaining the motor will not exceed that of machinery in any shop. The mo-

tor can be made to run at any speed that will be allowed, and will far excel the horse in this respect. In Scranton speed is obtained at an average of about 15 miles an hour.

The following details of the method used in Scranton show how electricity is applied to the moving of surface railroad-cars. When open cars are driven, one motor of 20 horse-power is placed in the middle of the car and all of the wheels are driving-wheels, the connection between the motor and the wheel-axles being made by means of chains and sprocket-wheels. But when closed cars are driven, a motor of 15 horse-power is placed on a closed platform at the front of the car; the forward wheels only are driving-wheels, and their connection with the motor is made in the same way as on the open cars, with chains and sprocket-wheels. The company intends to use also larger cars, each with a motor of 25 horse-power, which will not only propel themselves but be able each to haul two other cars, loaded with passengers, up all the grades. The average speed attained is more than 8 miles an hour, and there is no difficulty in going much faster; in fact, the men in control of the cars have to be watched to prevent their running at excessively high speed. At the generating station there are 2 stationary engines of 100 horse-power each, 2 dynamos of 100 horse-power each, and 4 boilers of 100 horse-power each; only one engine and dynamo, however, and two of the boilers being in use at the same time. The duplicate engine, dynamo, and boilers are for the purpose of providing against contingencies of accident to those in use, and also to allow of alternations in service, thus giving opportunities of frequent examination and inspection. Upon this railway the overhead system of conduction is employed, having flexible connection between the motor on the car and the carrier traversing the conductor, which is a solid copper wire, ¾ inch in diameter, suspended on a part of the route from transverse wires attached to wooden poles, 20 feet high and 6 inches in diameter, placed, at distances of 100 feet, on both sides of the street. On the rest of the line the wires are suspended from arms projecting sideways from wooden poles at the side of the railway, about 20 feet above the ground. As the line is a single-track railroad, there are several turn-outs, or passing places, at which points the electric overhead conductor branches off over the side track also; and an ingenious system is in use by which the carrier, running upon the overhead wire with two grooved wheels of about 2½ inches diameter, automatically shifts the connections at the points of divergence from the main line, so that the carrier always follows that one of the overhead conductors which is above the track upon which the car is travelling. The return current of electricity is taken by the rails. The electrical current has a tension of about 600 volts, which, while sufficient to give a shock, could not produce any dangerous effect on man in case the current should by any means be diverted. Part of the road is laid with tram-rails and the rest with T-rails, and only part is paved, so that these different conditions, in connection with the many grades and the curves and turn-outs, thoroughly test the working of the system. The noise of the carriers running on the conductors is not great, but the noise produced by the motors and the chain and sprocket connections is annoying. This could be entirely avoided by the use of a noiseless motor and a better method of connection. Noiseless and durable electric motors suitable for use on cars can be had, in which the weight per horse-power does not exceed 60 pounds. Electric railways with overhead conduction have shown their capability to propel a few cars, even if heavily loaded, at less cost and much greater speed than can be obtained by horse-power.

In the case of electrical railways with underground conduction, the effort has been made to give all the advantages of the overhead system. On account of the serious objection in most cities to having the conductors and poles or other supports obstructing the streets, attempts have been made to secure electric railways with underground conduction. But the costly conduit, and the needful arrangements for drainage and for cleaning out, together with the increased care necessary to provide against the considerable loss or leakage of electricity, which, nevertheless, generally takes place in spite of all precautions, detract greatly from the apparent advantages of the plan. Many inventions have been patented, and various devices contrived to overcome the objections of this method, but practical success has hardly yet been obtained. Neither by overhead nor underground conduction have more than a few cars as yet moved simultaneously upon railways, although many ingenious arrangements are offered by inventors who confidently assert they can run any required number of cars. Both plans also are open to another serious objection in the entire stoppage of travel on the whole line in case of breakage or derangement of any part of the conducting apparatus or the generating machinery. In this respect they suffer from the same disability by which the cable system of car-traction is hampered. Possibly by suitable arrangements of duplicate engines, boilers, and dynamos, duplicate conductors, and auxiliary, sectional, or relay systems of conduction, this disability may yet be reduced to insignificant proportions. Taken altogether, underground conduction does not compare favorably with overhead conduction up to this time. One great trouble with the latter plan, however, is that although it can be used to great advantage and economy on lines running a few cars in towns or in suburban districts outlying large cities, it will probably never be allowed by the municipal authorities in large cities, which, of course, are the very places where the advantages of electrical propulsion are needed the most. To move a large number of cars, as, for instance, upon the Third Avenue or Broadway lines in New York City, the electrical conductor, whether overhead or underground, must be of great size if the current is of low tension; while, on the other hand, if a small or moderate-sized conductor be used, the current must then be of dangerously high tension, and, of course, it would then be very difficult to avoid great loss of electricity from leakage.

In the accumulator or secondary-battery system, each car carries its own supply of energy, and is entirely independent of any method of continuous electrical conduction. No change of track or roadway is required, nor any costly conduit or unsightly poles or other supports, while the cars can run anywhere that a car can be taken by horses. These points are of great advantage, and are its chief merits, independent of its economy, over horse-power. In practice, cars of the size of the usual 2-horse cars are provided with about 80 accumulators, weighing when filled with fluid and ready for use about 40 pounds each. These cells are placed under the seats on each side of the car. Their combined weight is 3200 pounds, and the weight of 2 motors, each of 5 horse-power, should not, together with their connections to the car axles, exceed 800 pounds so that the additional weight imposed upon the car is about 4200 pounds, which allows 200 pounds for the apparatus to control the current and for other electrical appliances. This added weight, if placed upon a 4-wheel car, may be of disadvantage to the car or to the track. If this should be the case, the difficulty is removed by the use of 8 wheels on 2 swinging trucks, which support the car much better, and distribute the weight upon the track. Both

these kinds of storage-battery cars are in service with entire success. The charging of the cells is done by a dynamo driven by steam-power or any other desirable means, and it takes 4 hours to charge cells which are able to perform 4 hours' work. To remove from the car the cells which have done their work and to replace them by freshly charged cells takes no more than the time required to change horses. It requires 10 horse-power exerted for 4 hours, making 40 horse-power hours, to charge the batteries or cells of each car. The cost of running large stationary steam-engines of 200 to 400 horse-power, constructed with the modern improved cut-off appliances and other economical devices, has been found not to exceed $\frac{1}{3}$ cent per horse-power hour. This allowance includes fuel, attendance, repairs to engine and boilers, oil, etc. At 1 cent per horse-power hour the whole cost of a day's supply of electricity would be \$1.60. The expense of horses for the same work and time is not less than \$4.50. With motors properly constructed a speed of 8 or 9 miles per hour is readily accomplished—in fact, 8 miles per hour may be taken as the speed at which such motors will work to the best advantage and return the greatest percentage of mechanical efficiency. The requirements of street-car service demand variable rates of speed; as, for instance, in crowded streets, behind other vehicles, or in turning curves and entering switches it is necessary to go slowly and cautiously, and the weight of the load carried at different times varies from an almost empty car to one overloaded. These conditions, together with increased power needed to ascend grades and to start loaded cars, especially on up-grades, call for electric motors which will, under such greatly varying circumstances, respond at all times almost equally well. There are motors which, while engaged in performing an equal work and running at an equal speed, for both of which purposes the motor was specially made, will return 90 or possibly 95 per cent. of efficiency, while the same motor, when run at some different speed or under some different load, may return but 30 or 35 per cent., so that the average performance of such motors in street-car service would probably give only 50 per cent. return of efficiency. Motors can, however, be obtained which will, under all the variations of street-car work, constantly return 75 per cent. of efficiency.

A uniform rate of 5 cents is charged in almost every city of the United States. There are, however, street railroads which require from 6 to 10 cents because extra power is required upon hills, or because of long stretches of unoccupied territory along the tracks. A very careful investigation of the earnings of certain street railroads in New York City and Brooklyn, by the State board of railroad commissioners, has resulted in a statement that nearly all of them required but little over 4 cents per passenger in order to pay expenses, interest, and 10 per cent. yearly of the cost of the road and the equipment. In 1886 all the street railroads of New York City carried 206,000,000 passengers; while in 1887 the number was but 200,000,000. The several elevated railroads carried 115,000,000 passengers in the former year and 159,000,000 in the latter. The elevated railroads had scarcely begun their operations when the disadvantages of the surface roads became apparent; and the proprietors of the latter were stimulated to make great improvements. After various legislative attempts to guard the interests of the public, a general law was passed by the New York legislature, in 1884, for the construction and operation of street surface railroads in that State. Power was given to local authorities to make regulations as to the rate of speed, the mode of use of tracks, the removal of snow and ice, and the enforcement of compliance with all of these requirements under

heavy penalties. The rate of fare was limited to 5 cents. It was also provided that new roads may use the tracks of an old road for a distance not to exceed 1000 feet; and that all street surface companies may use any kind of power except steam. Immediately after the passage of this act, three companies (one being the Broadway) were formed to operate surface railroads in the city of New York. In 1886 a new law was passed to secure adequate compensation for the right to construct, maintain, use, operate, or extend street railroads. Stringent provisions were made in relation to giving such privileges to the highest bidder.

(F. O. M.)

STRIKES are combinations of workmen to enforce a demand for higher wages, and occasionally to obtain other ends, by refusing to labor under the rates and regulations of their employers. The word as used in this sense is much more recent than the thing. A strike on a large scale occurred in England after the plague of 1340, with destructive consequences to the harvests and to general business; the prevention of similar movements was aimed at by a statute of labor which required the poor to work at the old rates for any employer, and forbade them to move from one place to another, under various penalties.

In the United States strikes began at an earlier period than has usually been supposed. The journeymen bakers of New York struck in 1741, and were tried for conspiracy. An association of journeymen shoemakers in Philadelphia ordered strikes for increase of wages in 1796 and 1798; these were successful, and one to resist a proposed reduction in 1799 was partly so. The sailors' strike in New York, November, 1803, which was long thought the first in America, employed compulsion, and did not succeed; nor did another of the Philadelphia shoemakers in 1805. A "general turn-out" was ordered by the New York cordwainers in November, 1809: the term "scab" was at this time applied to the unfaithful member of a journeymen's association. In 1815 several cordwainers were tried and convicted of conspiracy at Pittsburg in connection with a strike. Some ship-builders at Medford, Mass., struck in 1817 for continued supplies of rum. The employment of a "rat" or non-union printer, at Albany, caused a strike among the printers there in 1821. In 1822 three hatters of New York were convicted of conspiracy. Sundry strikes of ship-carpenters and calkers occurred along the coast, 1825-30; one of tailors in Philadelphia, 1827, for the reinstatement of discharged comrades; one of laborers on the Chesapeake and Ohio Canal, 1829; and several of carpenters, masons, and machinists, in Boston and elsewhere, for fewer hours of labor, 1830-31. From this date strikes were so frequent that only the more important or significant of their incidents need be noted. The Boston merchants and ship-owners, at a meeting held May 15, 1832, resolved to employ no member of the unions. An unsuccessful strike of women engaged in binding shoes took place at Lynn, Mass., in January, 1834. Schuylkill merchants agreed on a lock-out, May 26, 1835; during this year various trades in Philadelphia were troubled by strikes. A riot at Rowley, Mass., May, 1840, began among railroad laborers in consequence of deduction of pay for being late. In 1847 a strike of 1200 journeymen tailors in Philadelphia lasted four months, and obtained the desired advance; in 1848 one of factory operatives at Allegheny City and elsewhere, after eight weeks' idleness and much rioting, secured the adoption of the ten-hour system with a reduction of 16 per cent. in wages. A strike in the mills at Fall River, Mass., 1850-51, kept 1300 persons idle for nearly six months, at a loss in wages of above \$140,000. One of iron-workers at Pittsburg, 1850, was accompanied with violence; many were

sentenced to fines and imprisonment, but pardoned. Salisbury, Mass., was much injured in 1852 by a strike of the mill-hands, caused by the abolition of a fifteen minutes' recess for lunch. The Lynn shoe-makers lost \$200,000 in wages by a strike, Feb. 22, 1860. The coal-miners in Western Pennsylvania and elsewhere struck in 1859, and 1862-63. In 1863 strikes were numerous. That of the Pittsburg stove-moulders in January, 1867, resulted in breaking up their union. The Pennsylvania legislature passed, in 1868, the eight-hour law; non-compliance with it on the part of the Mahanoy valley colliers produced an extensive strike in that region; the price of coal for many years has been largely affected by movements of this kind. The business of Schuylkill county was greatly injured by the contest of 1870, the miners refusing to accept the basis of \$2 per ton and then that of \$2.50, fixed by the firms, and successfully demanding \$3. During this year there was much trouble in the shoe-shops of Massachusetts, and Chinamen were introduced at North Adams. In January, 1871, a strike of miners began at Scranton, which extended throughout the whole anthracite field; it was settled by arbitration in May, but further increase of wages was gained in the fall.

The famous railroad strikes of 1877, which were attended by gross violence, immense destruction of property, and considerable loss of life, began at Martinsburg, W. Va., on the Baltimore & Ohio R. R., and extended to the Pennsylvania Central, the Erie, and many other roads. The lawless element of the community joined the strikers, and large mobs for a time had their own way at Pittsburg and elsewhere; the militia in some cases refused to act, and in others were worsted. The loss at Pittsburg, July 21-23, was estimated at \$5,000,000, \$2,000,000 of which was borne by the railroad; some 1600 cars with their contents, 126 locomotives, and nearly all the shops were burned, and much property stolen; traffic and travel were interrupted for a week. Disorders occurred somewhat later at Reading, Scranton, and other towns, as also at St. Louis and several places in Ohio.

These acts of violence, the destruction of the property of railroad companies and other employers, and the odious terrorizing and compulsion practised on men who wish to work, are frequent accompaniments of strikes, rather than properly a part of them; but they must be expected and reckoned with in considering the subject.

Volume XX. of the Tenth U. S. Census reports the strikes and lock outs of the year 1880 as numbering 762, of which 304 were in Pennsylvania, 104 in New York, and 93 in Ohio. Five hundred and twenty-four affected mechanical and manufacturing industries, 182 mining, and 50 trade and transportation. In estimating 813 causes and results, Mr. J. D. Weeks assigns 539 strikes to questions of wages and 71 to other difficulties: of 85 lock-outs, 78 related to wages; 118 causes were unclassified or mixed. Of the strikes 143 were successful, 70 were compromised, 156 failed, and 241 were not reported; of the lock-outs, the corresponding numbers were severally 10, 8, 34, and 33; of the cases unclassified, 16, 7, 37, and 58. The strikes in the mining region of Ohio, 1869-80, which attracted great attention, and frequently required the help of the militia to enforce the law, have been discussed by the Ohio bureau of labor statistics. The whole number of strikes and lock-outs recorded in the United States prior to 1881 is estimated at 1491, of which 1089 related to wages: 316 succeeded, 154 were compromised, 583 failed, and the result of 438 is unknown.

The statistics of this subject from 1881 to 1886 are very fully presented in the *Third Annual Report of the Commissioner of Labor* (1888). In 1881 2928 es-

establishments were affected by strikes, in 1882, 2105; in 1883, 2759; in 1884, 2367; in 1885, 2284; in 1886, no less than 9861. In every case the majority of these were closed, the average being 23 days. In these six years the aggregate of idle days was 487,615, with a loss to 1,660,835 employes of \$51,814,723, and to employers of over \$30,000,000. Very many of the old hands lost their work, and 37,483 were brought from other places. Nearly four-fifths of the strikes were ordered by labor organizations; over 10,000 succeeded, about 3000 won partial success, and nearly 9000 failed. New York was the State most largely affected; after it came Pennsylvania, Illinois, Connecticut, Ohio, Massachusetts, and Texas—judging by the number of persons involved; looked at from other points of view, the order differs somewhat. The chief industries concerned were building trades, 6075 houses; tobacco, 2959; mining, 2960; clothing, 1728; metals and metallic goods, 1570; transportation, 1478; food preparations, 1419. The lock-outs for the same years numbered 2214, of which 1753 were ordered by organization. About 564 of them succeeded and 190 in part, while 1339 failed. One thousand six hundred and twenty-five establishments were closed for an average of 28.4 days, with a loss to employers of \$3,462,261, and to employes of \$8,157,717. The proportion borne by the year 1886 in these totals is even greater than with the strikes.

The figures for New York during 1887 are given in the *Fifth Annual Report* of the State Bureau of Statistics for Labor. In that year strikes affected 1604 shops, including 144 trades and callings. Of these attempts 694 succeeded, 696 failed, 190 were compromised, 424 were yet pending. The number of workmen engaged was 51,731, only about two-fifths that of 1886; but the number to whom employment was afterward refused was greater, being 8176 as against 6391. The loss of wages was over \$2,000,000, and \$217,069 was spent by the labor organizations in aid to the strikers. Employers lost over \$1,100,000, and 11,472 persons acquired an increase of wages estimated at \$944,632. As to the causes of the strikes (which here include lock-outs also), 459, or only about 34 per cent., were for increase of wages; 158 were for a reduction of the hours of labor; 118 were due to refusals to handle boycotted coal or freight; 113 to the employment of non union men, and 11 to the discharge of members of the unions. The boycott showed an increase, 242 cases against 186 in 1886; of these 101 were professedly successful, 36 failed, and 105 were yet pending.

Bradstreet's report gives nearly 1000 strikes as occurring in the United States from Jan. 1, 1887, to April 1, 1888, 884 of which were in 1887—this number indicating movements, and not establishments affected, as in the N. Y. report above cited. Some 340,854 workers struck during 1887. Of these strikes, the most recent as to which statistics are available, it is instructive to note the more important. The year 1887 began with a strike of 2000 brewers in Philadelphia to resist a reduced schedule of wages; after four months it was partially successful. It was directed by a combination of local unions under the guidance of the Knights of Labor, from whom, however, the brewers withdrew as soon as their affair was settled. Far more important in its results was the strike of the coal handlers at Bayonne, Perth Amboy, South Amboy, and other places in eastern New Jersey at the same time. It failed after lasting six weeks, but the various associations of coal handlers in New York and Brooklyn followed, seeking a higher and uniform rate of wages. James E. Quinn, of District Assembly 49, assumed the leadership of the movement, instigated a series of sympathetic strikes, interrupted the movement of coal to New York so seriously that a coal famine was threatened, and called

out all the men connected with work on the wharves. Of these—longshoremen, boatmen, grain handlers, coal handlers, bag sewers, grain sealers, coal train brakemen, etc.—in New York, Brooklyn, and Jersey City, including the employes of the Dominion Steamship line, some 23,000 belonged to the several local assemblies, and 15,000 of them obeyed the call. The corporations resisted this effort to paralyze their trade, used strenuous efforts to procure new laborers, and employed a great number of Pinkerton detectives to protect these and the property about the wharves and tracks. Collisions occurred, and for several weeks the strike was the object of universal attention and wide anxiety. Quinn threatened and attempted likewise to affect the gas and electric light companies, the machine shops, breweries, etc., and practically to suspend all business in New York. He undertook too much; most of the local assemblies refused to obey. Then he tried, with but partial and temporary success, to call off the employes of the coal carrying roads terminating in and about Jersey City, and finally to paralyze the coal trade in New England and elsewhere. The main strike ended before the middle of February, having substantially failed some time previous. *Bradstreet's* estimates that above 34,000 men were engaged in it, with a loss in wages of \$2,650,000; the official figures of New York are 6574 men, and a loss of over \$400,000 in that State.—The drivers and conductors of the Consolidated Street Car Co. in Boston, offended by a new rule to pay them by the trip instead of by the day, struck, Jan. 11: they were members of District 30, K. of L., but acted independently of the Assembly. Public sympathy was with the men, and they won a complete victory in a single day.

A strike which began about this time among the shoe factories in Worcester Co., Mass., was turned into a lock-out by a combination of the employers, who refused to employ union men or to treat except with individuals. After five months the men, numbering 8000, were entirely defeated, with a loss in wages of \$2,500,000. The strike was directed by the leaders of District Assembly 30, the funds of which were largely expended in aid; but the strikers were dissatisfied, and ultimately withdrew and formed an Assembly of their own, K. of L. Toward the end of January 2400 employes of the Higgins carpet factory, in New York, struck against a proposed reduction of 10 per cent. in their wages; a compromise was effected after four days. In February they went out again, at the instigation of District Assembly 49, to aid the coal handlers, but two weeks' idleness resulted in a failure. Early in April, 7500 of the 8000 carpenters in Chicago, members of the local Trades Assembly, struck for fewer hours and more pay. The K. of L., to whom one-fourth of them belonged, interfered as "peacemakers," but the unions won a victory in a fortnight. Similar strikes of trades unions were induced by this success; in Cincinnati 1100 men were idle a week, and in Brooklyn 800 won after ten days. In April several movements of stove-moulders against certain boycotted patterns were merged into a general strike by the Amalgamated Association of Iron and Steel Workers; 3311 men in Chicago, Milwaukee, Keokuk, Quincy, Pittsburg, and elsewhere were affected, and won after being out from six to eight weeks. Early in May 5000 hod-carriers of Chicago struck, with the authority of the Trades Assembly. The result was complicated, and led to a combination and lock-out of the employers, whose terms were so severe (including a boycott on their men) as to suspend all building operations, and throw 15,000 men out of work. After nine weeks the workmen yielded. In May, 5000 shoemakers in Haverhill, Mass., and 2600 in Cincinnati, were locked out because of disputes as to wages; compromises were effected, speed-

ily in the former case, in the latter after a month. During the spring a strike of 13,000 coke-workers in the neighborhood of Pittsburg, members of the K. of L., failed after ten weeks, with a loss in wages of nearly \$1,000,000. Mr. Powderly condemned this strike as unauthorized. In May, 2000 brickmakers in Pittsburg lost a week and gained nothing. In June, 1200 carpenters of St. Paul and Minneapolis were idle nine weeks under authority of a trades union; the matter was compromised. In July, 4000 operatives of the Harmony Mills, at Cohoes, N. Y., struck for higher wages under direction of local leaders of the K. of L., who prolonged the struggle for two months by sending many of the hands to work elsewhere; the mills procured new operatives, and the strike failed. During the first half of 1887 *Bradstreet's* reckons 607 strikes, involving a greater number of workmen than the corresponding period of 1886. The failure of two-thirds of these movements caused a diminution in the following months. July 11, 106 engineers and firemen of the Brooklyn Elevated Road struck, giving but an hour's notice; their places were speedily filled, and the Brotherhood of Locomotive Engineers was signally defeated. In August, 2500 men in the rolling mills of Pittsburg struck because of an alleged violation of a rule; after a month they won their point. A similar contest began shortly after at Youngstown, O., involving 3500 men, who were successful after a fortnight. At the same time 2500 miners in the Hocking Valley, O., struck for a semi-monthly pay-day, and won in two days. In that month at Brockton, Mass., W. L. Douglas, a State senator and active member of the K. of L., locked out the workmen in his shoe-factory for resisting the use of labor-saving machines, dismissed the Knights in his employ, and made his shops "free," having therein the support of local public opinion. In August and September, 1100 cotton spinners at Fall River were out five weeks, and then accepted a compromise. Sept. 13, 1000 cigarmakers struck on a question of apprentices, and were defeated after nine days. A similar difficulty kept over 2000 glass blowers, in various factories in the East, out of work for a month or more, and was generally settled by a compromise; the usual result was a return from the K. of L. to the trades union. A very extensive and disastrous K. of L. strike among the Pennsylvania coal miners of the Shamokin, Mahanoy, Lehigh Valley, and other districts began, Sept. 10, lasted till January, 1888, and involved some 27,000 men, whose efforts to gain an increase of pay resulted in an estimated loss of \$2,500,000 in wages. In October the brass-workers of Brooklyn struck for a Saturday half-holiday without loss of pay, claiming that their employers had broken an agreement; they were locked out, and defeated after a month of idleness. At the same time the ale brewers and book printers of New York struck; the latter demanded increased pay, a regulation of the apprentice question, and the turning of every office into a union or "card" place. Their typographical unions, backed by the Central Labor Union, were opposed by the employers, who organized as "Typhothetæ." After three weeks a compromise was effected, the first claim being granted and the last denied. In October and November, 500 shoemakers were locked out for five weeks in Philadelphia, and brought to submission. A similar case occurred in Rochester; a union had attempted to dictate to employers, and 3500 men were locked out through December and half of January, 1888, with the same result.

Near the end of 1887 fears of a coal famine were aroused by an attempt to compel the Reading Railroad to discriminate against firms obnoxious to certain parties, as employing non-union men. The company declined to permit this interference with its business, and the K. of L. called out over 6000 of its

employés on Dec. 24, and threatened to extend the strike to all the coal-carrying roads and coal mines of Pennsylvania. But many of the Knights refused to obey; their authorities declared the strike illegal, and most of those who had taken part in it, having no prospect of support from the general fund, resumed work on the 27th. A smaller attempt on the next day proved equally abortive; but the matter assumed more serious shape in January and February, 1888, through many strikes of coal miners, partly in sympathy with the railroad employés, partly in search of 8 per cent. advance in their own wages. President Corbin of the Reading R. R. was involved in a contest with the Executive Board of the K. of L., which represented and directed the miners in the company's collieries. Ultimately these returned to work at the old rates. The losses were estimated at no less than \$3,620,000 in wages to full 30,000 men, \$1,000,000 to the company, and \$700,000 to consumers in increased prices of coal, besides considerable sums to private collieries.

An even more momentous and alarming strike, attracting general attention for many weeks, began with the engineers of the Chicago, Burlington, and Quincy Railroad, who sought an adjustment of wages similar to the schedules of other roads. For a time trade was nearly paralyzed in portions of the West, gross disorders were perpetrated at points far apart, and lawless confusion seemed to triumph. The affair is too recent for an accurate estimate of what it cost the country.

Of the 884 strikes commenced in 1887, 247 were successful, and 115 partially so: these two classes concerned 128,234 employés, or 38 per cent. of all—nearly twice the proportion of 1886. Of them all, 542, or 63 per cent., were for increased wages or a shorter day's work; 225, or 26 per cent., came from trades union demands of other kinds; 68, or 8 per cent., were "sympathetic strikes;" the small remainder is unclassified. Pennsylvania and New York were most affected, with 111,317 strikers and 62,656, respectively. The trades chiefly concerned were coal and coke, with 70,450 men; transportation, 62,379; building trades, 56,560; iron and steel, 29,989; leather, shoes, etc., 28,805; textiles, clothing, etc., 25,328; patterns and machinery, 10,000; tobacco, 8,000. The building trades lost the greatest number of days, 1,492,078: boots and shoes follow, with 1,291,943. The entire number of days during 1887 employed in successful strikes was 1,774,694, while 5,081,315 were thrown away on failures. Some 3,000,000 days must be added for strikes still in progress at the end of the year, making 10,000,000, or about a month for each, of near 350,000 strikers. If these earned an average of \$1.50 a day when at work, the total loss in wages for 1887 would be some \$13,500,000. The loss to business interests in general, and to consumers in increased prices of goods, cannot be estimated with any degree of accuracy.

It cannot be said that strikes are never beneficial to the striker: the figures prove the contrary. More than this, the fact that they are frequent and always possible may go far to check the rapacity of some employers, and to win respect for the hand that wields so dangerous a weapon; yet it seems as if civilization might have devised some less cumbrous and costly method of coming to an understanding. The problem is more difficult in an ethical than in an economical view. Under free institutions the right of the workman to better his condition if he can, and to combine in order to that end, is unquestionable; and no less so the right of the employer to manage his business in his own way, and to employ such persons and under such regulations as he sees fit. The natural jealousy between Labor and Capital tends to make each careless of the other's interests and claims: employés have sometimes de-

manded increased wages at a time when the business was being conducted with little profit or actual loss, so that increased expenses would have meant ruin; and employers have often regarded their workmen as machines, and neglected or refused to allow them any share in the great profits of a fortunate season. Greater mutual consideration and consequent harmony may come through the advance of education, intelligence, and character; and a definite remedy has been found (whenever wisely tried) in co-operative schemes, which make the operative a partner, however humble, and no longer a mere instrument. Short of this happy climax, which requires largeness of mind if not benevolence in the capitalist, legislation must strive more and more to suppress those aggressions, alike on public welfare and on personal liberty, which cannot be tolerated in a free state. The tyrannies of dictation and the enormities of the boycott, from whatever quarter and in whatever interest, must be restrained. The abuse of power, whether by walking delegates or by wealthy corporations, is alike incongruous with American ideas. The constant liability to sudden stoppage of the wheels of modern life, of railroad and telegraph and traffic, by whatever means it is to be averted, cannot be endured much longer. Strikes, lock-outs, and their accompaniments, are the rude resources of an incomplete civilization. (F. M. N.)

STRINGHAM, SILAS HORROR (1798-1876), admiral, was born at Middletown, N. Y., Nov. 7, 1798. Entering the navy as midshipman in 1809, he took part in the engagement of the frigate *President* with the *Little Belt*, and was made lieutenant in 1814. He served in the Algerine war, and afterward along the Slave coast of Africa. In 1821 he was engaged in suppression of piracy in the West Indies. He rose to be captain in 1841, and in the Mexican war took part in the bombardment of Vera Cruz. In 1853 he took command of the Mediterranean fleet, and afterward was in charge of the Boston navy-yard until the civil war broke out. He was then summoned to Washington to advise the government in regard to naval affairs. He was placed in command of the North Atlantic blockading fleet and conducted an expedition to Hatteras Inlet, where two forts surrendered after bombardment, Aug. 29, 1861. Retiring from active service in the following December, he resumed his command of the Boston navy-yard. In 1862 he was promoted rear-admiral on the retired list, and in 1870 was made port-admiral of New York. He died at Brooklyn, Feb. 7, 1876.

STRONG, GEORGE CROCKETT, a soldier in the civil war, was born, Oct. 16, 1832, in Stockbridge, Vt. His father dying while he was a child, he was brought up by an uncle, A. L. Strong, Northampton, Mass. He entered West Point Military Academy and was graduated in 1857, and assigned to the ordnance with the brevet rank of 2d lieutenant. In 1859 he was promoted to 2d lieutenant, and became assistant at Watervliet arsenal, West Troy, rising to the command in 1861, when he became 1st lieutenant. On the outbreak of the civil war he sought active service, and was on the staff of Gen. McDowell as ordnance officer at the first battle of Bull Run, and afterward served in the same capacity on the staff of Gen. McClellan. He had in October, 1861, been appointed assistant adjutant-general of volunteers, with the rank of major, and was engaged in the organization of the New Orleans expedition, which he accompanied. In April, 1862, he commanded the expedition from Ship Island to Biloxi, Miss., and in September led the successful expedition to Pontchartroula, where he destroyed a large train and broke up Jeff. Thompson's headquarters. In November, 1862, he was made brigadier-general of volunteers and became Butler's chief of staff, but in December he was compelled to withdraw on sick

leave to New York, where he remained till June, 1863, having been commissioned captain of ordnance in the previous March. He commanded a brigade in the operations against Charleston, S. C., and led the successful attack upon Morris island, where he was the first to land. While leading the second assault on Fort Wagner, on July 18, and cheering on the storming column, he was mortally wounded, after having gained the parapet of the fort. He was at once removed to New York City, where he died, July 30, 1863.

STRONG, JAMES, a layman, honorably entitled to the degree of S. T. D., was born in New York City, Aug. 14, 1822. In his youth he began the study of medicine, but after graduating at Wesleyan University, Middletown, in 1844, he became a teacher. His health failing, he became a farmer, and soon was active in improving the village of Flushing, L. I. He had there entered upon a course of Biblical study, and when giving instruction in ancient languages he prepared manuals of their grammar. His first larger work was a *Harmony and Exposition of the Gospels* (1852), originally prepared for the English version, and afterward adapted to the Greek. In 1856 he received the degree of S. T. D., and from 1858 to 1861 he was professor of Biblical literature in Troy University. His series of *Lessons for Every Sunday in the Year*, in which he was aided by other writers, was the precursor and model of the International Sunday school series. In 1868 Dr. Strong was made professor of exegetical theology in Drew Seminary at Madison, N. J. He took part in the revision of the English Old Testament. In company with Rev. Dr. John McClintock he prepared the well-known *Cyclopaedia of Biblical, Theological, and Ecclesiastical Literature* (10 vols., 1867-79). He also edited Daniel in Schaff's edition of *Lange's Commentary*, and some other Biblical works.

STROSSMAYER, JOSEPH GEORGE, Croatian archbishop, was born at Essek in Slavonia, Austria, Feb. 4, 1815. He was educated at the University of Pesth, obtained the degrees of doctor of philosophy and of theology, and, after having spent some time in the Augustinian convent at Vienna, was ordained priest in 1838. He was soon made professor in the seminary at Diakovar, then court-chaplain, and in 1849 was consecrated bishop. His diocese extended over Croatia and Servia, and he became the head of the Croatian national party in opposition to the Hungarians. Primary instruction was fostered, a seminary established for Bosnians, and a university opened at Agram. Here also an academy was instituted, with a fine gallery of paintings on national subjects and by native artists. A handsome cathedral was erected at Diakovar, and at Rome Archbishop Strossmayer caused the ancient Illyrian chapel of San Girelamo to be restored. In the Austrian Reichsrath, to which he was elected in 1860, the archbishop favored a federal union of the various nations and races composing the empire. The Croatian leaders, finding themselves unable to secure home-rule, accepted the compromise offered by the Hungarians giving the Slavonic people representation in the Hungarian diet, and Strossmayer then withdrew from political affairs. At the Vatican Council in 1870 he made open and strenuous resistance to the promulgation of the doctrine of papal infallibility, and finally left Rome without accepting the dogma. Even in a later visit to the Holy See he persisted in his attitude of ignoring the action of the council. In his efforts to preserve and advance the Croatian national spirit Strossmayer has published many historical and popular works. The most important is *Monumenta Slavonorum meridionalium* (Rome, 1863). For an interesting sketch of this "Father of his People," see Laveleye's *Balkan Peninsula* (1887).

STROTHER, DAVID HUNTER (1816-1888), artist, author, and soldier of the civil war, born at Martinsburg, Va. (now W. Va.), Sept. 26, 1816. He studied drawing in Philadelphia, and afterward, under Samuel F. B. Morse, in New York. After travelling in the Western States he went, in 1840, to Europe, where he remained 5 years. On his return, in 1845, he studied in New York the art of drawing on wood for engravers, and illustrated some books. From 1852 to 1861 he contributed to *Harper's Magazine*, under the name "Porte Crayon," a series of illustrated articles, chiefly on Virginia and the South, some of which appeared in book-form under the title of *Black Water and Virginia Illustrated*. On the outbreak of the civil war he volunteered into the United States service, and was appointed captain and assistant adjutant-general, rising to the colonelcy of the Third West Virginia Cavalry. In 1864 he resigned, and in 1865 was brevetted brigadier-general "for meritorious services." He returned to his home at Berkeley Springs, where for some years he continued to supply sketches to the magazines. In 1879 he was appointed consul-general to Mexico, and held the office till 1885. He died at Charleston, W. Va., March 8, 1888.

STRUVE, OTTO WILHELM, Russian astronomer, was born at Dorpat, Russia, May 7, 1819. There his father, Dr. Wilhelm Struve, became pre-eminent through his researches on double stars, and, by his influence with the Emperor Nicholas, brought about the erection of the Pulkowa Observatory in 1840. As assistant to his father Otto made a catalogue of many hundred double stars, before unknown as such. His work determining the constant of precession, popularly called the annual amount of motion of the equinox among the stars, won the gold medal of the Royal Astronomical Society in 1850. He has determined the parallax of several stars, made a series of observations on the rings of Saturn, has observed several solar eclipses, and had general charge of the geodetic operations in the Russian Empire. In 1862 he succeeded his father as director of the observatory. In 1879, acting under the authority of the Russian government, he contracted for a larger refractor than any yet made; with Alvan Clark & Sons, of Cambridge, Mass., for a 30 inch object-glass; and with Repsold, of Hamburg, for the mounting. This telescope has been in operation since 1885. (See OBSERVATORIES and TELESCOPES, in the ENCYCLOPEDIA BRITANNICA.) Otto Struve's greatest work, the result of thirty-five years' observations of the double stars, was published in 1878, in the ninth volume of the *Pulkowa Observations*.

STUART, GEORGE HAY, president of the U. S. Christian Commission during the civil war, was born at Rose Hall, county Down, Ireland, April 2, 1816. In early manhood he emigrated to America, and settled in Philadelphia, entering into mercantile life. He was active in forming the Young Men's Christian Association of that city, and was for many years its president. He also assisted in the national and international organization of these associations. This work, bringing him into contact with representative Christian men of all parts of the country, was a fitting preparation for the work of the Christian Commission, which he undertook when the officers of the Sanitary Commission refused to become agents of funds for ministering to the religious needs of the soldiers. The great work thus neglected was energetically taken up by Mr. Stuart, and successfully carried through. His labors won the approval of General Grant, and of nearly all the Union generals. After the war Mr. Stuart took up more urgently the cause of Christian union, and in 1867 called and presided over a convention in Philadelphia of delegates from all branches of the Presbyterian Church, to consider a plan of union. Though this convention did not

succeed in its grand purpose, it certainly prepared the way for the reunion of the Old and New School branches, effected in 1870. Mr. Stuart, however, had still remained an elder in the Reformed Presbyterian, and was subsequently suspended from his office by a synod of that denomination for a technical offence. The sentence, however, remained inoperative, and Mr. Stuart, with the congregation to which he belonged, eventually joined the Presbyterian Church in 1880. He had always been prominent in every movement for the promotion and extension of Christianity, and was an officer in many societies for such purpose. While a merchant he was vice-president of the Mechanics' Bank, and in 1880 he became president of the newly formed Merchants' Bank. His labors had often been interrupted by severe attacks of asthma, and in 1888 he was obliged to retire from business.

STUART, JAMES EWELL BROWN (1833-1864), a Confederate cavalry officer, was born in Patrick Co., Virginia, Feb. 6, 1833, his grandfather having been an officer in the war of the Revolution and his father in that of 1812. After spending two years at Emory and Henry College, Salem, Va., he entered the U. S. Military Academy, whence he graduated in 1854. At both institutions he was noted for his deep religious convictions. On leaving West Point he joined, as 2d lieutenant, the regiment of mounted riflemen then stationed in Texas, and did good service against the Apaches. Next year he was transferred, with the same rank, to the First U. S. Cavalry, which was on duty in Kansas during the border troubles. In this year, also, he married the daughter of Col. Philip St. George, and next month was promoted 1st lieutenant. In 1857 his regiment was engaged in Indian warfare, and he was wounded in an action with the Cheyennes on Solomon's River. Being in Washington in the close of 1859, he volunteered as aide to Lieut.-Col. Robert E. Lee, in his expedition to Harper's Ferry to quell the John Brown insurrection, and identified its leader as "Osawatimie Brown," whom he had known in Kansas. Thereafter he rejoined his regiment, but, obtaining leave of absence in March, 1861, he returned to Virginia, and on the secession of that State resigned his commission. The State authorities forthwith appointed him lieutenant-colonel of Virginia infantry, and, in July, colonel of cavalry. His first active service in his new sphere was in screening the movements of Gen. Joseph E. Johnston from Gen. Robert Patterson when he advanced from Winchester with re-inforcements for Gen. Beauregard on the eve of the battle of Bull Run. In this fight Col. Stuart greatly distinguished himself by his effective defence of Gen. Jackson's left flank, repulsing the assaulting Union force, and thereby contributing no little to the Confederate victory. For his conduct here, as well as for other services, he was in September, 1861, appointed brigadier-general. In the Virginia peninsular campaign he covered Gen. Jos. E. Johnston's rear in his retirement from Yorktown and Williamsburg. In June, 1862, he was directed by Gen. R. E. Lee (to whom the command of the troops for the defence of Richmond had now fallen) to make a raid round the rear of McClellan's army, now lying on the Chickahominy, inflicting as much damage on it as possible, and determining the position of its left. On June 12th he sallied out of the Confederate lines before Richmond at the head of 1200 men and some light artillery, and in the course of three days passed entirely around the Army of the Potomac, destroying a large amount of stores at Tunnstall's Station near McClellan's base of supplies at the White House, recrossing the Chickahominy by a ruined bridge, and returning up the James to Richmond, with McClellan's forces on his one flank and the Union gun-boats on

the other. He brought back with him 165 prisoners and his own corps entire (save one man), and, at the same time, information that enabled Lee to make a successful assault on the Union right wing at Gaines' Mill on the 27th. For this brilliant achievement and his services in the Seven Days' fight he was in July—though not yet 30 years of age—promoted to major-general. Soon thereafter he marched north to support "Stonewall" Jackson in his operations against Gen. John Pope, then in command of the Army of Virginia. On Aug. 22 he crossed the Rappahannock, penetrated Pope's encampment at Catlett's Station, captured his despatch-book and baggage, and made prisoners of several officers of his staff. Two days later he was ranking officer in the attack on Manassas Junction, and sent into the town a brigade of infantry, under Brig.-Gen. Trimble, that made many prisoners and captured valuable stores. At the second Bull Run fight he rendered important service by guiding Longstreet to an effective junction with Jackson that resulted in Pope's army being driven back upon Washington. In the ensuing Maryland campaign he led the advance of Jackson's corps, and rendered efficient service at South Mountain and Antietam. Next October (9-12) he made a daring raid across the Potomac, at the head of 1800 picked troops, on Chambersburg, Pa., where he destroyed property to the value of \$250,000 and carried off much booty, the entire cavalry force of the Army of the Potomac being wearied out in pursuing him. He took part in the battle of Fredericksburg, being on guard on the extreme left of the Confederate line. His next noteworthy exploit was a raid on Dumfries, in which, by means of spurious telegrams to Washington, he learned the movements in contemplation by the leaders of the Union forces. In March, 1863, a portion of his force was successfully attacked at Kelly's Ford by the National cavalry under Gen. Averell. At the battle of Chancellorsville his cavalry covered "Stonewall" Jackson's advance to the right of the Union line, and when that distinguished soldier fell, mortally wounded, the command of his corps devolved temporarily on Stuart, who not only extricated it from the critical position into which it had been carried in the darkness, but next day renewed the attack, and, pushing onward, joined the right wing under Lee at Chancellorsville, then abandoned by Hooker. In the succeeding Gettysburg campaign he was sent forward to guard the flanks of Lee's advancing columns, and had several encounters with the enemy, with varying success, as at Fleetwood Hill, Stevensburg, Aldie, Middleburg, and Upperville. At the passage of the Potomac he received permission to repeat his favorite tactical movement of passing behind the enemy's rear, and accordingly crossed the river between the Union army and Washington. The detour was wider than had been calculated on, and he did not reach Gettysburg till the evening of the second day of that eventful conflict (July 2), and so was in time only to take part in the closing struggle and to cover the rear of the retreating Confederates by guarding the gaps of the mountains. This raid, which deprived Lee of his cavalry at a most important crisis for the Southern cause, has been much criticised, the responsibility for it being especially the subject of controversy. When the Confederates lay entrenched on the northern bank of the Potomac, Stuart's cavalry had many conflicts with those of Gen. Judson Kirkpatrick and John Buford, as well as, later in the summer, with those of the above generals and of Gens. Alfred Pleasonton and Henry E. Davies, when holding the line of the Rappahannock. When Grant entered the Wilderness in May, 1864, his chief of cavalry, Philip H. Sheridan, at the head of 12,000 troopers, advanced on Richmond. Stuart in-

stantly hurried to interpose between him and the city, concentrating his force at Yellow Tavern. Here a desperately contested fight took place, in which Gen. Stuart was mortally wounded and his men routed. He died at Richmond, May 12, 1864. Till Sheridan came on the field to contest the palm with him, Stuart was undoubtedly the foremost cavalry commander in either army. The novelty, boldness, and rapidity of his movements—in a word, their dash and brilliancy—combined with their general success, invested him with a halo of romance, and brought him to be regarded as the Rupert of the South. (J. N.)

STUART, MOSES (1780-1852), Hebraist and Biblical theologian, was born at Wilton, Conn., March 26, 1780. At twelve he read Edwards on *The Freedom of the Will*, and at fourteen mastered the Latin grammar in three days. Entering Yale as a sophomore, he graduated in 1799, taught school for two years at North Fairfield and Danbury, studied law, and, just before his admission to the bar, 1802, was appointed tutor at Yale. Here he remained two years, studying theology with Pres. Dwight, till licensed to preach by the New Haven Association, 1804. On March 5, 1806, he was ordained pastor of the First Church in New Haven. After nearly four years' eminently successful ministry, he resigned his charge to become professor of sacred literature at Andover, Feb. 28, 1810. His first publication was a Hebrew grammar without points (1813), printed largely by his own hands, and previously used in MS. by his students, who copied the sheets as fast as he wrote them. Though many lamented his withdrawal from the pulpit, he was invaluable in the professor's chair, which he retained till 1848. Of his students over 1500 became ministers of the gospel, over 70 college presidents or professors, and over 100 foreign missionaries, of whom 30 translated the Bible into foreign languages. On these he exerted a powerful influence, and so stimulated zeal and enlarged facilities for study in his department as to earn the title of "Father of Biblical literature" in America. His principal publications were *Letters to Channing* (1819, six editions); *Grammar of the Hebrew Language*, with points (1821), highly commended at Oxford; *Letters to Samuel Miller, D.D. on the Eternal Generation of the Son of God* (1822); a translation of Winer's *New Testament Grammar*, with Prof. E. Robinson (1825); *Commentary on the Epistle to the Hebrews* (2 vols., 1827-28; 1 vol., 1833); on the *Epistle to the Romans* (2 vols., 1832; 1 vol., 1835); *Hebrew Chrestomathy* (1829); *Principles of Interpretation*, from the Latin of Ernesti (4th ed., 1842); *Grammar of the New Testament Dialect* (2d ed., 1834); *Notes to Hug's Introduction to the New Testament* (1836); *Hints on the Prophecies* (2d ed., 1842); *Critical History and Defence of the Old Testament Canon* (1845); *Commentary on the Apocalypse* (2 vols., 1845); a translation of Rödiger's Gesenius' *Hebrew Grammar* (1846); *Commentaries on Daniel* (1850), *Ecclesiastes* (1851), and *Proverbs* (1852); *Conscience and the Constitution*, called forth by Daniel Webster's speech (1850). Besides these he wrote 14 pamphlets, and some eighty contributions to the *American Biblical Repository*, the *Bibliotheca Sacra*, and other periodicals, amounting to over 3000 octavo pages. He died at Andover, Jan. 4, 1852. Strange to say, he never obtained the degree of D. D., though highly deserving it.

STUBBS, WILLIAM, English bishop and historian, was born at Knaresborough, June 21, 1825. He was educated at Ripon and at Christ Church College, Oxford, graduating in 1848. He was then made fellow of Trinity College, and, being ordained priest, became vicar of Navestock. As the first-fruits of his antiquarian and historical researches, he published in 1858 *Registrum Sacrum Anglicanum*, which,

by its precision of statement and correction of the errors previously abounding in civil and ecclesiastical histories, firmly established his reputation. In 1862, becoming librarian to Archbishop Longley, of Canterbury, he was enabled to pursue still further researches, which resulted in his careful editing of many early English chronicles. In 1866 he was made professor of modern history at the University of Oxford, and in 1869 curator of the Bodleian Library. He published *Select Charters and other Illustrations of English Constitutional History* (1870). All his previous labors led up to his most important work, the *Constitutional History of England in its Origin and Development* (3 vols., 1874-78). His freedom from party spirit and scrupulous fidelity to facts have laid the foundation for a better understanding of English history. In 1875 he was made rector of Cholderton, and in 1879 canon residentiary of St. Paul's. He held this position, together with his professorship at Oxford, until 1884, when he was appointed Bishop of Chester.

STUCKENBERG, JOHN HENRY WILBURN, philosopher, was born at Bramsche, Germany, Jan. 6, 1835. Having emigrated to America in early life, he graduated at Wittenberg College, Ohio, in 1857, afterward studied at German universities, and became pastor of Lutheran churches in Iowa and Pennsylvania. During the civil war he was chaplain of a Pennsylvania regiment for a year. In 1873 he was made professor of theology in Wittenberg College, and in 1880 he went to Berlin, where he was placed in charge of the American Chapel. He assisted Rev. W. L. Gage in translating Hagenbach's *German Rationalism* (1866). He has published, *Ninety five Theses* (1867); *History of the Augsburg Confession* (1869); *Christian Sociology* (1880); *Life of Immanuel Kant* (1882); *Introduction to the Study of Philosophy* (1887).

STURGEON, the largest fresh-water fish of the northern hemisphere, to which it is exclusively confined. The sturgeon belongs to the primitive order of cartilaginous armored fishes known as Ganoids, of which order it is probably the youngest representative, no trace of it having been found beyond the Eocene formation. In conformity with the Ganoids it has free gills, and is more or less covered with bony plates in longitudinal rows, the tail is heterocercal, and the skeleton cartilaginous. The sturgeons constitute a family, *Acipenseridae*, with two genera, of which *Acipenser* is the most impor-

See Vol. XXII.
p. 611 (p. 643
Am. Rep.).

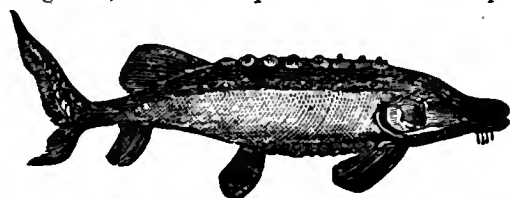

Sturgeon (*Acipenser sturio*).

tant. The common sturgeons of Europe and America were classed as separate species by the older writers, that of America being known as *A. oxyrinchus*, but they differ but little, and are now generally classed together as *A. sturio*. This species is ordinarily about six feet in length, though in rare cases it reaches a length of 18 feet. Its body is long and slender, gradually tapering, and covered throughout by large, bony tubercles. In color it is of a grayish brown above, silvery on the lower sides, and white below. It is found along our coast as far south as Florida, entering the rivers to spawn, during which season it is taken in great numbers. The flesh is white and firm, and affords excellent food, though less used for that purpose in this country

than in Europe. The ova of the sturgeons are very small, yet the ovaries are so large as in some species to make up nearly one-third of the entire fish, so that the number of eggs is enormous. It may equal 3,000,000 for a single female. It is probably due to this fact that the sturgeons remain undiminished in number, despite the vast multitudes that are annually taken in the rivers of Europe and America. In addition to the use of the flesh as food, the roe is employed to make the food-substance called caviare, a favorite viand in Russia. The making of caviare was formerly confined to Europe, but is now carried on somewhat extensively in America, the sturgeon-fisheries of the Hudson and Delaware, for instance, being largely devoted to this industry. Isinglass, which is made from the inner coat of the air-bladders, is another important product of the sturgeon. As an evidence of the extent of the sturgeon-fisheries, it may be stated that more than 200 tons of caviare yearly have been produced from the catch of the rivers flowing into the Caspian Sea.

In addition to *A. sturio*, the Atlantic waters of the United States possess another species, *A. brevirostris*, distinguished from the former by its shorter and blunter nose. It is less abundant, and is not found north of Cape Cod. Both species frequent the rivers and estuaries in great abundance in summer, when they may be frequently seen leaping from the water. They spawn in the lower stretches of the rivers, and partly in the brackish water at their mouths, where they seem to obtain food by grubbing in the mud for its living creatures. Within a few years the taking of the sturgeon for smoking and the manufacture of caviare has attained considerable importance in several of the larger rivers flowing into the Atlantic.

The Pacific coast also has two species, *A. transmontanus* and *A. medirostris*. The former of these, known as the "white sturgeon," is a large species, attaining a length of 8 feet or more and a weight of 400 or 500 lbs., though seldom found of over 150 lbs. weight. It abounds in the Sacramento, Columbia, and Frazer rivers, ascending them at the same time as the salmon, and is an important food-fish in the San Francisco markets, where it is always abundant and very cheap. It is little used as food in its fresh state elsewhere, on account of the abundance of salmon, but is smoked, and caviare made of its roe. *A. medirostris*, the "green sturgeon," is of the same size and distribution as the "white," but is much less abundant, and is not used for food, being reputed to be poisonous.

Another species of considerable commercial importance, *A. rubicundus*, has its home in the Great Lakes, and in the Mississippi and its tributaries. It is particularly abundant in the upper lakes, of which it is the largest fish, though much smaller than the other species named. Its extreme weight is 100 lbs., and its average length less than 5 feet, though there are traditions of 9-foot sturgeon having been taken. It lives on the shell-fish of the lakes, spawns in the early summer months, and is caught in great quantities, the fishery lasting from September 10th to the middle of October. It is not popular as a food-fish, though palatable when properly cooked, but its flesh is pickled and smoked in considerable quantity, and much caviare made from its eggs. This is done by pressing them through a sieve till they are free from all particles of membrane, and then putting them into salt pickle.

The second genus of sturgeons, *Scaphyrhynchus*, differs from that described in several particulars, principal of which are the lack of spiracles, and the confluence of the osseous bucklers on the tail, which they entirely cover. Four species are known, all exclusively fresh-water in their habitat. America possesses *S. platyrhynchus*, which inhabits the Missis-

sippi and other southern rivers, and attains a length of 5 feet. It is not highly valued as a food-fish. Large as are some of our American sturgeons, they are surpassed in size by certain species of Europe. One species of the river-systems of the Black and Caspian seas is said to sometimes attain a length of 20 to 25 feet, and a weight of nearly 3000 lbs. (c. m.)

STURGIS, SAMUEL DAVIS, general, was born at Shippensburg, Pa., June 11, 1822. Entering the U. S. Military Academy in 1842, he was graduated and promoted as 2d lieutenant, Second Dragoons, in 1846. During his service in Mexico he was captured near Buena Vista, February 20, 1847, two days before the battle, and was not released until eight days after. He served after the Mexican war at Jefferson Barracks and Fort Leavenworth, and engaged in Indian warfare from 1854 to 1857, especially with the Apaches, and was promoted to captain, First Cavalry, in 1855. He continued on frontier duty until the opening of the civil war, and became major of the First Cavalry, in August, 1861. He was distinguished in the battles of Dug Spring, Mo., and of Wilson's Creek in August, 1861, under Gen. Nathaniel Lyon, whom he succeeded in the command when that general fell. He received the brevet of lieutenant-colonel for services in those battles, and was made brigadier-general of volunteers, Aug. 10, 1861. He was in command of the defences of Washington from May to August, 1862, fought in the second battle of Bull Run, Aug. 29, 1862, and was with the Army of the Potomac at South Mountain, and at the battle of Antietam. In the battle of Fredericksburg, Dec. 13, 1862, he commanded the second division of the Ninth Army Corps, and for his conduct there was brevetted colonel. Constantly active in military operations, he was promoted to lieutenant-colonel in October, 1863, and took part in the military operations in East Tennessee, in the fall of that year and the beginning of the next. Here his restless activity found abundant occupation, especially in conflict with Gen. N. B. Forrest, against whom he was successful. At the close of the war he was brevetted major-general in the regular army. He was mustered out of the volunteer service in August, 1865, and was thereafter engaged on frontier duty, becoming the colonel of the Seventh Cavalry in May, 1869. He served as superintendent of the recruiting service in St. Louis in 1874, and commanded on the Yellowstone expedition from May to October, 1877. He was placed on the retired list of the army on June 18, 1886. (u. c.)

STUYVESANT, PETER, director-general of the New Netherlands, was born in Holland in 1602, his father being a Frisian clergyman. He served in the West Indies, was director of Curaçoa, lost a leg in an attack on the Portuguese island of St. Martin, and then returned to Holland. The Dutch West India Company next appointed him director-general of the New Netherlands, where he arrived in 1647, forthwith establishing a court of justice and, in deference to the popular will, ordering a general election of 18 delegates, from whom he selected his advisory council. Toward the Indians, whom his predecessor, William Kieft, had provoked to hostilities, he adopted a policy of conciliation, and earnestly endeavored to improve their condition as well as that of the colonists generally, by the introduction of well-meant reforms. He prohibited the sale of liquor as well as of fire arms to the savages, enforced a rigid observance of Sunday, erected a better class of houses and taverns, founded a public school, and established a market and annual cattle fair. In 1650 he met the New England commissioners at Hartford, and with them arranged a line of partition between the Dutch and English territories, which had been hitherto in dispute. His conduct of the

arrangement, however, was not satisfactory to the Dutch, who declared he "had ceded away territory enough to found fifty colonies, each fifty miles square." In 1651 the Dutch built Fort Casimir, on the Delaware River (then called the South River in contradistinction to the Hudson or North River), which the Swedes claimed to be an encroachment on their rights, and, under their governor, Rising, captured the fort in 1654. Next year Stuyvesant sailed up the Delaware, with 7 vessels and 600 or 700 men, and took possession of the whole settlement of New Sweden. For the next ten years there was unbroken peace on the exterior, but discontent began to show itself at home. In 1653 a convention of two delegates from each village in the colony demanded that "no new laws shall be enacted but with the consent of the people; that none shall be appointed to office but with the approbation of the people; that obscure and obsolete laws shall never be revived." Stuyvesant indignantly ordered the convention to disperse on pain of condign punishment, haughtily replying: "We derive our authority from God and the Company, not from a few ignorant subjects." The embers of discontent, however, continued to smoulder, and encroachments from abroad came to further harass the governor. In 1664 Charles II. granted to his brother, the Duke of York (afterward James II.), all the territory from the Connecticut River to the shores of the Delaware, and four English war-ships, under Captain Richard Nicholls, bearing 450 men, appeared in August in the bay, and demanded the surrender of the city of New Amsterdam. Stuyvesant sent a defiant answer to Nicholls and prepared for resistance. But the municipal authorities, seeing little hope of successful defence and being but indifferently disposed toward their Dutch masters, insisted on yielding, and on Sept. 9, 1664, a treaty was signed at Stuyvesant's house, on his farm or *bowery*, by which the city was surrendered to the English. Its name was forthwith changed to New York, and the designation soon extended to the whole province. Stuyvesant went next year to Holland to report to his superiors, but soon after returned to his farm, whose name still survives in the *Bowery*, New York city. There, in the country, he passed the remaining 18 years of his life, dying in August, 1682. He was buried in the vault of a chapel, belonging to the Reformed Dutch Church, that he had erected on his grounds. Its site is now occupied by St. Mark's Episcopal Church on the corner of Stuyvesant Street and Second Avenue, where his gravestone, bearing an inscription, is to be seen built into the wall. His dwelling-house was destroyed by fire in 1777.

SUGAR. The etymology of the word "sugar" points to a Hindu origin, the form of the word in Sanscrit being *sarkara*, whence it may be traced in differing forms through all the Aryan languages. It is doubtful, however, if all these names originally referred to the same product, since sugar does not appear to have been known in the ancient European world, though it was probably in use from a remote period in India and China. The sweet substance known as sugar is principally of vegetable origin, but occurs to some extent in animals. It is soluble in water, generally crystallizable, neutral to vegetable colors, and is an organic chemical compound of Carbon with Hydrogen and Oxygen in the proportions to form water; that is, 2 parts of Hydrogen to 1 of Oxygen. There are two generically distinct sugars: The Saccharoses or Sucroses, $O_{12}H_{22}O_{11}$; and the Glucoses, $O_{11}H_{22}O_{10}$. The latter, which are much less sweet than the former, have been already treated (see *GLUCOSE*). The former, Saccharose or Sucrose, ordinarily known as Cane-sugar, comprise several varieties, differing in taste and appearance,

See Vol. XXII. p. 623 (p. 655 Am. Rep.).

though alike in chemical composition. Cane-sugar is found in the stems and roots of many grasses, especially sugar-cane, sorghum and Indian corn; in fleshy roots, as the beet, carrot, turnip, sweet potato, etc.; in the sap of many trees, especially the date-palm and sugar-maple; in most sweet fruits, pumpkins, melons, sweet potatoes, etc.; and in the nectar of flowers and glandular exudations of certain plants. Of the total sugar-product the sugar-cane yields about 60, the beet-root 35, the date-palm 3.5, the sorghum-plant 1.75, and the sugar-maple .5 per cent.

The Sugar-cane, *Saccharum officinarum*, is a kind of gigantic grass, with a solid stem, 1 to 1½ inch thick and 8 to 10 feet high. The stem is jointed at distances of 3 to 6 inches, and sends forth leaves 3 or 4 feet long, which fall with the ripening of the plant. The flower stem, called the "arrow," is 7 or 8 feet high, smooth and jointless, bearing a panicle of soft, silky flowers. The ripe stem contains a pith of dirty-white color and open cellular tissue, which is filled with the saccharine juice of the plant. Numerous varieties of sugar-cane are cultivated, differing much in character, though most botanists think that they all came from one species. Of these varieties those most cultivated in this quarter of the world are the Creole or Madeira (the common sugar-cane), and the Otaheite, a taller variety, whose yield is larger and its juice more easily worked. The Batavian, Chinese, and other varieties are cultivated to some extent. The Salangore is one of the most prolific, and has been known to yield as much as 7200 lbs. of sugar from one acre of canes. The sugar-cane thrives best in warm, moist climates, and finds its most luxuriant development on islands and sea coast regions, perhaps from the moisture of the sea-breezes. It reaches its greatest perfection within the tropics, and cannot be successfully cultivated in frosty regions. Even in Louisiana it is often injured by frost.

The sugar-cane, which had long before been cultivated in the West Indies, was introduced into the United States about the middle of the last century. It is said to have been brought by Jesuits from San Domingo, and cultivated on the banks of the Mississippi, above New Orleans, about 1751. Some authorities say that the first sugar-mill was built on the Mississippi in 1758, and that the culture prospered; but others say that the manufacture of cane-sugar did not begin till 1764, and did not prosper, there being very few sugar-estates in Louisiana when ceded to the United States in 1803. In 1818 25,000 hogsheads of sugar were made. Up to that time the cane was ground by cattle, but steam-grinding was introduced in 1822. The sugar-district at present extends on both sides of the Mississippi, from about 60 miles below New Orleans to nearly 200 miles above, and also along Red river and many bayous. The culture has been introduced into Texas and is increasing in all the Gulf States. Yet in all these States the cane is liable to injury from frosts, which occasionally cause serious reduction of the crop, while droughts and the overflow of rivers also act injuriously. The sugar-cane is exposed to many animal pests, chief among which are rats. These gnaw the standing canes, and let the air into the pith and juice, fermentation and acidity resulting. White ants are also very troublesome in some localities, while there are several borers, plant-lice, etc., which do great injury to the canes. Various more or less effective methods have been introduced to mitigate these pests, the mongoose being employed successfully by some planters to get rid of the rats; while turkeys, insectivorous birds, ichneumon flies, and ants are useful as natural enemies of the boring larvæ.

The cane is propagated only by means of cuttings, no kind of cultivated sugar-cane being known to

perfect its seed. These cuttings are planted at intervals of 2 feet, in rows 3 feet apart, though this differs in different localities. Hand-holes are dug to set out the cuttings, though this method is being replaced, particularly in Louisiana, by the use of the plough. After the first cutting, new plants, known as "ratoons," grow up from the roots, and this method of growth is sometimes continued for 20 years before the vitality of the old roots is exhausted. When the canes are ready for harvest they are cut with hatchets as close to the root as possible, the juice from the lower joints being the richest. The tops are discarded. The canes are crushed in mills by heavy rolls, an average yield of 60 per cent. in juice being thus obtained. There is great loss in this method, however, and a new process, known as diffusion, is now becoming general. In this the pith is treated with successive applications of water, into which the juice diffuses, the yield being much greater and the juice purer, while the residuum of molasses, being free from plant-tissue, is of better quality.

Next in importance to the cane as a sugar-producer is the Beet-root. Up to the 18th century only cane-sugar was known in commerce, but in 1747 it was discovered that beets contained about 6 per cent. of sugar. During the Napoleonic wars, when the English blockade deprived France of sugar, Napoleon had experiments made on many plants, and, as beet-root proved the best, a beet-sugar factory was established at Lillo in 1810. After the peace this industry, which had gained considerable development in France, declined, but improved processes brought it into vogue again, and at present beet-root sugar has largely driven cane-sugar out of Europe. The efforts to introduce the beet-root sugar industry into the United States have not met with much success. An attempt was made by Vaughan and Ronaldson, of Philadelphia, in 1830, but failed from ignorance of the proper process. At that time the European beet yielded only 4 to 5 per cent. of sugar, though the present yield is from 8 to as high as 14 per cent. In 1839 D. L. Child, of Northampton, Mass., made 1300 lbs. of beet-sugar. Nothing further of importance seems to have been done till 1863, when a large factory was established at Chatsworth, Ill. Other factories have since started in that region, but none of them have been very successful. In 1860 experiments in beet-root sugar-making began in California, and in 1870 the Alvarado Sugar Co. was formed. Other companies have since been established, with good promise of success. Yet they have met with difficulties from want of experience, while there are obstacles in making beet-sugar which do not exist in the case of cane. The product of sugar is but two-thirds that of cane, while the juice is highly charged with impurities which need removal by expensive processes. The total annual product of beet-root sugar in this country is estimated at 2000 tons, but there are indications of a steady increase. (See AGRICULTURE, Chap. V. 2. Beet.)

The chief native source of sugar in the United States is the Sugar- or Rock-maple, a tall and ornamental tree which flourishes widely throughout North America, though its abundance has been greatly reduced by the too free use of the axe. Its sap yields a profitable percentage of sugar, but the manufacture of sugar from it has as yet been mainly confined to farmers for home consumption. The season of maple-sugar making is very favorable for farmers, being in the early spring before the beginning of farm-work. At the first thawing of the ground, in middle or late February, the flow of sap begins, and the sugar-making continues through March and into early April, though the sap gradually diminishes in its saccharine qualities. The sugar-sap season is thus about six weeks long, the average product of sugar being one pound to 4½ or 5 gallons

of sap. In a good season an average tree will yield, during the best period of flow, as much as 3 gallons of sap daily, and produce about 4 pounds of sugar during the season. There are exceptional cases on record of 10 to 40 lbs. from a single tree. Trees, when fully mature, may be tapped many years without injury, there being cases of the same tree being tapped for 40 years without apparent harm.

The process employed in collecting the juice is to notch the tree 1½ inch deep with an axe, or to bore auger-holes, the sap being caused to flow into collecting vessels. Three persons, it is said, can attend to 250 trees. The sap is evaporated in iron caldrons or shallow boilers, yielding a sugar of peculiar appearance and taste. The annual product of maple-sugar is estimated at 10,000 tons, but the data are not reliable. In Nebraska an equally good sugar is made from the ash-leaved maple, while some other American trees promise well as sugar producers. Vermont is the principal State engaged in the maple sugar industry. At the last census this State surpassed its nearest competitor, New York, by 2,200,000 lbs.

Maize or Indian corn was a source of sugar to the ancient Mexicans, and the maize-plants that bear no seeds are so sweet that the Mexican children are said to be as fond of them as of sugar-cane. It has been used to some slight extent for this purpose in Southern Europe and the United States, but a far more important sugar-yielding plant is the Sorghum, or Chinese Sugar-cane, which has been experimented upon with very promising results. The seeds of this plant were first brought to Europe in 1851, and to the United States in 1854. They were distributed among farmers, and found to flourish, in proper soil, from Maine to Texas. The culture rapidly spread, especially in the western States, mainly for the purpose of making molasses, though the leaves made excellent food for cattle. Until quite recently the sorghum-juice was almost wholly made into molasses. The census of 1870 reports only 24 hogsheads of sorghum-sugar, with 16,000,000 gallons of molasses. The census report of 1880 makes no mention of sorghum. The product had apparently fallen to unimportant dimensions. But since 1880 improvements in sorghum-sugar making have been introduced which promise to greatly revive that industry, it being possible to produce sugar of excellent quality from sorghum at a cost much below that of Louisiana cane-sugar. The powerful machines used to crush cane are not needed in the case of sorghum, which can be crushed much more easily. The area of possible sorghum-culture is extensive, being nearly the same as that of Indian corn, and while cane-sugar is profitable only on large plantations, sorghum can be raised profitably by ordinary farmers. The industry promises, therefore, to become an important one in the United States. (See AGRICULTURE, Chap. V. 4.)

Another source of American sugar is the Melon (*Cucumis melo*), which has assumed some little importance, particularly in California. Usually the juice is only evaporated to molasses, whose flavor is said to be much superior to that of beet-sugar. As a source of commercial sugar, melons cannot compete with cane or beet. Other sources of sugar are milk, which is used to some extent for this purpose in Switzerland, and the juice of several species of palm, particularly that of the wild date-palm, from which sugar is made in many tropical regions. The artificial conversion of starch into sugar was first effected by Kirchoff at St. Petersburg in 1702. The sugar thus produced is glucose, differing generically, as we have said, from sucrose. The making of it has become an extensive industry of late years in Europe and the United States. One further source of the sugar-product of this country is imported

molasses, which is largely used for the making of low grades of yellow sugar. The receipts of foreign and domestic molasses at the port of New York in 1880 was 14,849,760 gallons. Much of this, and of the molasses received at other ports, is worked over again for the sugar it contains.

An approximate estimate of the annual production of sugar in America outside the United States may be made from the replies to an inquiry addressed a few years ago by the Agricultural Department at Washington to the United States consuls at various American ports. These replies yield the following tabular statement of the American sugar-product:

Mex'co, exports, 1885-87.....	6,289,208 lbs.
Lower California, annual product.....	2,400,000 "
Costa Rica, 1884 product.....	8,6300 "
Guatemala, 1886 product.....	21,672,750 "
Nicaragua, annual product.....	2,240,000 "
Salvador, annual product.....	18,000,000 "
Brazil, 1884-85 product.....	570,000,828 "
British Guiana, 1886 product.....	250,555,200 "
Dutch Guiana, 18 6 product.....	15,355,751 "
Ecuador, annual product.....	11,000,609 "
Venezuela, annual product.....	15,500,000 "
Pe.u, annual product.....	89,690,000 "

The last-named country is excellently adapted to sugar-production, and in 1876 its crop was about 165,000,000 pounds, with promise of large increase through irrigation and the introduction of Chinese labor. But the war with Chili, the beet-root sugar competition, and other adverse influences have caused a considerable falling off in later years.

The West India product, as given in the same reports, is as follows:

Jamaica, average annual product.....	51,821,620 lbs.
Trinidad, 1886 export.....	118,523,940 "
Santa Cruz, 1885-86 product.....	17,925,222 "
Guadeloupe, 1886 product.....	88,207,307 "
Guadeloupe, 1887 estimate.....	132,300,000 "
Martinique, 1886 product.....	66,581,760 "
San Domingo, 1886 product.....	35,497,715 "
Porto Rico, estimated annual product.....	170,400,000 "
Cuba, total product for 1886 (estimated from another source).....	1,505,810,880 "
Barbadoes, 1884-85 (estimated from another source).....	135,968,000 "

Of the Cuban product, which is about one-third that of the whole world, 93.55 per cent. of the export comes to the United States. The product of cane-sugar in the United States is much less per acre than in the well-cultivated West India islands. In Barbadoes the yield per acre is about 5800 lbs.; in Louisiana, about 1350 lbs. The product of this country declined from 217,577 hogsheads in 1850 to 87,043 in 1870. This was in consequence of the war, during whose continuance the sugar-crop ran very low. It has been on the increase since 1870, and has again reached the amount of 1850. It is doubtful if it will increase considerably beyond this, and may, perhaps, ere many years, be surpassed by the sorghum-product. The following figures give the Louisiana production for several successive years.

1851.....	231,191,000 lbs.
1860.....	255,115,750 "
1865.....	10,800,000 "
1870.....	99,452,949 "
1880.....	198,062,378 "
1881.....	272,982,899 "
1882.....	159,874,950 "
1883.....	303,006,258 "
1884.....	287,712,230 "
1885.....	211,402,963 "
1886.....	286,626,486 "

The product of the other Gulf States, during the same period, has ranged from 5,000,000 to 16,000,000 lbs., the amount for 1886 being 16,128,000 lbs. During the same period the importations of foreign sugar into the United States have grown to so enormous dimensions as quite to dwarf the Louisiana product.

The figures for successive years are as follows :

1851	380,402,280 lbs.
1860	644,888,197 "
1870	1,196,753,549 "
1880	1,829,291,684 "
1881	1,946,745,285 "
1882	1,990,152,374 "
1883	2,137,607,865 "
1884	2,556,416,816 "
1885	2,717,881,953 "
1886	2,689,881,765 "

The sugar produced from other sources in the United States was, in 1883, as follows : Maple, 41,410,000 lbs. ; beet-root, 1,344,000 lbs. ; sorghum, 896,000 lbs. ; while the total consumption has grown from 917,109 tons, in 1880, to 1,389,125 tons, or 3,111,640,000 lbs., in 1886, the latter being a consumption of 53.3 lbs. per capita of population. In addition to the quantity consumed there were exported from the United States, in 1886, 175,836,220 lbs., almost entirely composed of sugar refined from imported sugars. The sugar refining process in the United States has of late years grown to enormous proportions, and forms one of our most important industries.

The total world's product of sugar was estimated some years ago at 3,500,000,000 lbs. (which has since more than doubled), of which 66.47 per cent. was cane, 27.87 beet, 4.29 palm, and 1.28 maple. Of this sugar the greatest consumers are peoples of the Gothic and Teutonic stock, the English and their offshoots being the highest. This group consumes 2,460,000 tons annually ; the Latin group not more than 465,000 tons ; and the Slavonic, 265,000 tons. The annual consumption of English-speaking peoples is about 1,850,000 tons. (c. m.)

SULLIVAN, SIR ANTHON SEYMOUR, an English composer, was born in London, May 13, 1812. His father was professor at Kneller Hall, the training-school of the British military bands. The son was in boyhood chorister in the Chapel Royal, St. James's, and at the age of 14 competed successfully for the Mendelssohn scholarship. He studied under Bennett and Goss, and afterward at the Leipzig conservatory. He returned in 1861, bringing music for Shakespeare's *Tempest*. His next work was the cantata *Kenilworth*, for the Birmingham Festival of 1864. Then followed various overtures and oratorios, among which were *The Prodigal Son* (1868) and *The Light of the World* (1873). Meantime he had also commenced the series of operettas by which he is most widely known. The first of these was *Cox and Box* (1866) ; more successful were the *Trial by Jury* (1875) and *The Sorcerer* (1877). In these he was first associated with Mr. William S. Gilbert, who devised the dramatic parts, while Mr. Sullivan composed the music. The success of these operas was completely eclipsed by the authors' next joint labor, *H. M. S. Pinafore* (1878), which soon passed around the world, with constantly increasing applause. *The Pirates of Penzance* (1879) was a remarkable second to the foregoing. Then came *Patience* (1881) and *Islandie* (1882), with great popularity assured by the authors' fame, but not increasing it. For his contributions to sacred music the University of Cambridge conferred upon Sullivan the degree of doctor in music in 1876, and Oxford gave the same degree in 1879. In 1883 the Queen conferred upon him the rank of knighthood. From 1876 to 1881 he was principal of the National Training School of Music. In his song-writing he has attained greater popularity than any other composer.

SULLIVAN, JOHN (1740-1795), a general of the Revolutionary war, was born in 1740 at Somersworth, N. H. Till called to take up arms he practised law successfully at Durham, N. H., and was elected a delegate to represent his State in the first Continental Congress at Philadelphia, in 1774. Returned to the

second Congress, he was appointed by it in June, 1775, a brigadier-general, and proceeded at once to the field. Here, proving himself brave, discreet, and skilful, he was quickly promoted to major-general. At the siege of Boston he was next in command to Gen. Lee, and in the battle of Long Island, when Gen. Greene was disabled, Sullivan succeeded to the command of his division. Acting, subsequently, under the immediate eye of Washington, he gained the great leader's confidence by his conduct in the battles of Trenton, Princeton, Brandywine, and Germantown. In 1778 he was assigned to the command of the forces in Rhode Island, and stood ready to act in concert with the French fleet under Comte d'Estaing in an attack upon the British at Newport when the project was defeated by the retirement of the count on the appearance of the British fleet. After repulsing an attack of the enemy, Sullivan withdrew his troops with such skill and success as to earn the thanks of Congress.

In 1779 Congress was aroused by the massacres in Wyoming and Cherry Valley, perpetrated by the tribes of the Six Nations (Iroquois), and Washington determined to send a strong force under a resolute leader to take vengeance, and at the same time destroy a source of support for the enemy. Sullivan received the command, and, June 18, set out from Easton on his toilsome march. On Aug. 29 he came upon the Indians, with some British and Tories, under Joseph Brant (*g. r.*), entrenched at Newtown (Elmira). These he, after a struggle, dispersed, and thereafter set himself to the work of devastation. Forty villages were burned down, crops and orchards destroyed everywhere, and many savages slain. On Oct. 13 he returned to Easton, with only trifling loss. In 1779 Gen. Sullivan retired from the army and returned to his practice in Durham. Here he was the recipient of many honors from his native State, being chosen its delegate to Congress, its attorney-general, and three times its president. In 1789 he was appointed by Washington judge of the United States court of New Hampshire, which office he held till his death, in 1795.

SULLY, JAMES, an English psychologist, was born at Bridgewater, Somersetshire, in 1842. He was educated at the Independent College, Taunton, the Regent's Park College, London, and graduated at the University of London in 1866. He afterward studied at the University of Göttingen, and in 1871 entered on a literary career. He has contributed to the *Fortnightly* and *Westminster Reviews*, and is the author of several articles in the ninth edition of the *ENCYCLOPEDIA BRITANNICA*. Among his separate works are *Sensations and Intuitions* (1874) ; *Pessimism : a History and a Criticism* (1877) ; *An Introduction to Psychology* (1883).

SULLY, THOMAS (1783-1872), painter, was born at Horncastle, Lincolnshire, England, in June, 1783. His parents removed to the United States in 1792, and he began to paint at Charleston, S. C. In 1803 he went to Richmond, Va., then to New York, and afterward to Philadelphia, painting portraits in each of those cities. In 1837 he visited England to paint Queen Victoria in her coronation robes. This painting is owned by the St. George's Society of Philadelphia, and was lent by the society for the celebration of the Queen's Jubilee in 1887. Other noted portraits by Sully are those of Jefferson, now at West Point, of Lafayette, of Decatur, of Fanny Kemble Butler, of Dr. Benjamin Rush, and of George Frederic Cooke. His Washington Crossing the Delaware, now in Boston, has been popularized by engravings. Sully illustrated some books, but his fame rests on his portraits. He died in Philadelphia, Nov. 5, 1872.

His son, **ALFRED SULLY** (1821-1879), graduated at West Point in 1841, and served in the Florida and

Mexican wars. At the outbreak of the civil war he was still a captain, but was soon promoted major and colonel. During the Peninsular campaign he commanded a brigade, and he fought at Antietam, Fredricksburg, and Chancellorsville. In 1863 he was sent against the Indians in Dakota and was brevetted brigadier-general for his services there. In 1870 he was appointed colonel of the 19th Infantry. He died, April 27, 1879.

SULPHUR. This very important element is found widely distributed in earth and sea, in chemical combination in gypsum and pyrites, and dissolved in the ocean in the form of sulphates. It is also evolved from volcanoes and from vents in the earth in former volcanic regions, the principal American sulphur deposits being derived from sulphur vapor which has arisen from the interior in this manner and become condensed at the surface. Sulphur springs are numerous in the United States, and indicate a very general distribution of this element, either free or combined with hydrogen. In the eastern United States sulphur deposits occur on Cayuga Lake, and at Springport, Cayuga Co., N. Y.; on the Virginian side of the Potomac, about 25 miles above Washington; on Put-in-Bay Island, Ohio; in Kansas; at Tampa, Florida; and in Louisiana. These deposits are too small to have any industrial significance, except that of Louisiana. Here sulphur is found in Calcasieu parish, 13 miles from Lake Charles. The bed is a deep one, being reached only at a depth of 425 feet. It is said to average 100 feet in thickness and to be quite pure, and is underlaid by a bed of gypsum and sulphur. Some effort has been made to mine it, but with little success. An accident caused the works to be abandoned, and only recently have mining operations been renewed, with little result as yet.

Extensive and valuable beds of sulphur exist in some of the Pacific States, and here more vigorous efforts have been made to mine it, though the cheapness of Sicilian sulphur has caused the abandonment of many of the mines. Large deposits have been found in the Uintah Mountains of Wyoming, and also in southeastern Idaho, though these have not been utilized, from lack of railroad facilities. Sulphur also occurs in several localities in New Mexico and California. Some of the Californian deposits are large, but none, except that near Clear Lake, have been utilized, on account of the absence of cheap transportation. At Clear Lake the sulphur vapor issues from fissures in the rock, and is condensed near the surface. A peculiar feature of this deposit is the existence of a notable percentage of cinnabar in association with the sulphur. Borax also occurs in the vicinity. Sulphur was refined at this locality from 1865 to 1868, but the operations were then abandoned, on account of the fall in price of imported sulphur at San Francisco.

In Nevada sulphur is found in the craters of extinct hot springs in the Sage desert. There are many of these deposits, but of no commercial value. The sulphur beds in Humboldt county, Nevada, on the borders of the Black Rock desert, have been worked at the Rabbit Hole mines. The hills which here bound the desert have at their foot a strip of stratified volcanic tufa, which, at the locality of the mines, is richly charged with sulphur, all its interstices being filled with this element. The sulphur is of volcanic origin, and extends for several miles along the hills, in superficial deposits. The Humboldt Sulphur Company formerly produced 20 tons daily, but Sicilian competition has stopped the works.

A deposit of sulphur was found in 1885 in the mountains of Ventura county, Cal., but has as yet been used only for local purposes. In Utah the Mormons used sulphur purified from native ore for

some years. These deposits exist at Cove Creek, about 22 miles east of Black Rock, on the Utah Central Railroad. Here, as in the other places named, the sulphur has been deposited from vapor coming up from a great depth. This is still in progress, the prospecting holes becoming quickly lined with beautiful crystals of pure sulphur. In some localities the beds are 25 feet thick. In the four principal claims the mass of sulphur is estimated at 1,350,000 tons, much of it of high purity. The Cleveland mine, put in operation in 1885, yields ore of a remarkably high percentage of sulphur, it averaging at least 75 per cent., and frequently reaching 90 or over. Nowhere else do volcanic deposits of sulphur exist in such massive beds. This locality has, moreover, one advantage over the other American mines and those of Sicily in the presence of abundant fuel, the deficiency of fuel being a serious detriment to the Sicilian sulphur industry. All the sulphur produced in the United States at present is from the Cove Creek deposits, amounting to 3000 tons in 1887.

In addition to the American localities for sulphur above named, there are large deposits in Alaska, occurring near volcanic cones in the Aleutian and other islands. Sulphur mines exist in Japan, China, India, Turkey, Austria, Spain, Iceland, and the Samoa and Philippine Islands, but the principal supply comes from Sicily, though recently a considerable quantity of sulphur has been received in this country from Japan, and the importations from this source are increasing. The Sicilian sulphur, in addition to its abundance and cheapness of production, is free from arsenic, the most troublesome impurity, and is highly prized in the sulphuric acid manufacture. The annual product of the Sicilian mines increased from 143,323 tons, in 1862, to 376,316 in 1879, and is still increasing. The quantity of crude sulphur imported into the United States in 1886 was 117,538 tons, worth \$2,237,989, with over 3000 tons of refined sulphur, and flowers of sulphur in addition. Sulphur has declined rapidly in price of late years, falling from \$31 per ton of crude, in 1881, to \$19.50 in 1887. This is due principally to the rapidly increasing consumption of pyrites in the manufacture of sulphuric acid. Pyrites promises to yield an acid satisfactory for ordinary purposes more cheaply than ordinary sulphur, the impurities in this acid being too slight to detract from its value in refining petroleum and manufacturing fertilizers. Sulphur is being used in increasing quantities as "sheep dip," to prevent certain skin diseases in sheep. It is used in limited quantities in the gunpowder manufacture, in California to protect the vineyards from mildew, in the manufacture of ultramarine at Newark, N. J., and for some other purposes. Yet these consume but a small percentage, and nearly the whole product is consumed in the sulphuric acid manufacture. In 1884 about 306,000 short tons of this acid were made in the United States from crude sulphur, and 122,000 tons from pyrites. (C. M.)

SUMACH, the common name of plants of the genus *Rhus*, a wide-spread genus of shrubs or small trees of the order *Anacardiaceae*, an order embracing the cashew, mango, and other tropical fruits. There are about 12 species of sumach within the United States, two of them marked by dangerously poisonous properties. They have compound leaves with alternate leaflets, and small polygamous flowers in terminal or axial panicles. In the sumachs proper the leaves are pinnate and the flowers in a crowded panicle; the fruit globular, and clothed with acid hairs. There is no plant more highly ornamental in autumn than the sumach, its long leaves then changing in color to a yellow, dark red, or brilliant scarlet, and forming one of the most beautiful ornaments of our autumn forests.

Of the American sumachs the largest species is *Rhus typhina*, the Staghorn or Virginia Sumach, which attains a height of from 10 to 25 feet, with a woody stem, and irregular or crooked branches. The young shoots are covered with a soft, velvety down like that on the new horns of the stag, which they resemble. The leaves are large and slightly downy beneath, changing in autumn to a purple or yellowish red. The flowers are greenish yellow in hue, in close spikes at the end of the branch, succeeded by drupes or berries densely clothed with crimson hairs. There are many varieties of this species, which is found wild almost throughout North America. On cutting the stem a yellowish resinous juice exudes. The wood and leaves are used for tanning the finer kinds of leather, while the roots are prescribed as a febrifugal medicine. The branches, when boiled with the berries, yield a black, ink-like tincture, and the berries may be employed in dyeing red. They are of a pleasantly acid taste, and may be eaten with impunity. They are said to contain malic acid in large proportion, and are used as a substitute for lemons in medicine, and in various domestic preparations.

R. glabra, the Smooth Sumach, closely resembles the above, and is the most common species. It reaches a height of from 2 to 12 feet. Like *R. typhina* it bears a dense cluster of greenish-yellow flowers, and of crimson fruit, velvety from its numerous hairs, and with pleasantly acid taste, its long compound leaves having from 11 to 31 leaflets. But its young branches are smooth instead of downy. A third species of the same group, *R. copallina*, the Dwarf or Mountain Sumach, is from 1 to 7 feet high, with downy branches, and its petioles wing-margined. It bears from 9 to 21 leaflets, whose dark-green hue and smooth, shining surface make this species a very handsome one. It frequents rocky hills, but may be found in lowlands. The three species above named, but particularly *R. glabra*, from its greater abundance, are of considerable commercial value, for their use in tanning light-colored leathers, in dyeing, and calico printing. The leaves are gathered somewhat extensively in Virginia and neighboring States for tanning purposes, they being dried, beaten, and ground to powder. They contain 12 to 20 per cent. of tannin. The Sicilian Sumach, *R. coriaria*, which is largely cultivated in Sicily for the same purpose, is much richer in tannin, containing from 30 to 35 per cent.

Another group of *Rhus* contains two very common and very poisonous plants, *R. toxicolendron* and *R. venenata*. Their flowers and fruit are borne in long and slender axillary panicles, and their leaves have fewer leaflets than the species described. *R. toxicolendron*, commonly known as Poison-ivy, is a widely extended plant. It has two forms, an erect and a climbing; the latter, which climbs by aid of rootlets over trees and fences, having been described as *R. radicans*. This species has three leaflets, and yields a milky juice which blackens on exposure and stains indelibly. It is dangerous from its wide distribution and its poisonous properties, which produce a highly disagreeable cutaneous eruption, attended with violent itching, in those who touch the plant. *R. venenata*, known as Poison or Swamp Sumach, Poison-elder, and Poison-dogwood, is a low tree of 10 to 20 feet high, with 5 or 6 pairs of leaflets, greenish-yellow flowers, and greenish-white fruit, which hangs in loose clusters from 6 to 8 inches long. It yields a milky juice which dries to a black varnish, resembling the Japanese lacquer. The leaves are smooth and shining, and the tree a very handsome one. In the autumn the leaves change to an intense red or purple. This species is found in swamps and moist, shady situations, from Canada to Louisiana. It fortunately does not affect

dry situations, like *R. toxicolendron*, as it is much more virulently poisonous than the latter, being dangerous to most persons who touch it, and to some who come near it. For an unknown reason some persons may handle it with impunity. Its effect is to produce small cutaneous pustules, filled with watery matter, and itching and burning severely, the effect lasting for a week or two, though yielding to certain remedies. The use of very hot water relieves the itching sensation, and it is said that carbonate of soda, bound on with a cloth and kept wet, is a sure and rapid cure for the eruption.

Of other American species may be named *R. aromatica*, the Sweet-scented Sumach, whose leaves when crushed yield an agreeable odor. In the western varieties of this species the odor is strong and heavy. Its leaves are among those smoked by the Indians in place of tobacco, under the name of Killi Kinick. *R. cotinus*, a Mediterranean species used for tanning, is the ornamental Smoke-tree of our gardens. In this species the leaves are simple. Of other important foreign species may be mentioned *R. succedanea*, from which Japan wax is obtained. This wax exists as a thick coating on the seeds, and is obtained by boiling. It is made into candles which resemble white wax and give a fine, clear light. *R. vernicifera*, a shrub much like *R. venenata* in appearance and in its poisonous properties, yields a milky juice which blackens on exposure, and forms the varnish used in the well-known Japanese lacquer ware. What are known as Chinese galls are yielded by another species, *R. semialata*. They result from the deposit of the eggs of an insect in the young shoots, and are largely imported into England for tanning and dyeing purposes. (c. m.)

SUMNER, EDWIN VOSE (1797-1863), general, was born in Boston, Mass., Jan. 30, 1797. He passed his youth at Milton, Mass., and received his education at the academy there. After a brief mercantile experience he was appointed, in March, 1819, 2d lieutenant of Second Infantry. He served with high credit in the Black Hawk and other border Indian wars, being promoted 1st lieutenant in 1823, and captain, Second Dragoons, March, 1833, in which capacity he commanded the school of cavalry practice, then at Carlisle, Pa. Commissioned major in 1846, he distinguished himself in the war with Mexico, leading the famous cavalry charge at Cerro Gordo, where he was wounded, and brevetted lieutenant-colonel. He gained fresh laurels at Contreras and Churubusco, and at Molino del Rey commanded the entire cavalry, holding in check 5000 Mexican lancers. For this exploit he was brevetted colonel. In 1851-53 he was governor of New Mexico, when he was selected to visit Europe to report on improvements in cavalry. In 1855 he was promoted colonel and led a successful expedition against the Cheyennes, whom he defeated at Solomon's Fork of the Kansas river. While in command of the Department of the West he rendered faithful service in the troubles in Kansas. In February, 1861, he had command of Pres.-elect Lincoln's escort from Springfield to Washington. In March he was promoted brigadier-general of regulars, and sent to supersede Albert S. Johnson, in command of the Pacific Department, but was recalled next year to lead the First Corps of the Army of the Potomac under McClellan. At Yorktown he was in command of the left wing, and from here to Malvern Hill, in spite of his advanced age, he distinguished himself in almost every engagement. At Fair Oaks his services were especially conspicuous, it being due to his soldierly promptitude in crossing the Chickahominy to the support of the attacked left wing that the battle was not a disaster. In the course of the Seven-days-fight he was twice wounded. For his services in the Peninsular campaign he was, in July, 1862, brevetted

major-general in the regular army. At Antietam he succeeded Hooker in command of the Union right, and gained the main successes in the fight, though again wounded. He commanded one of the three grand divisions of Burnside's army at Fredericksburg, and was assigned to make the disastrous attacks on Marye's Heights, Dec. 13, 1862. At his own request he was relieved in 1863, and was ordered to the Department of the Missouri. He was on his way thither when he died at Syracuse, N. Y., March 21, 1863. His son, bearing the same name, is a colonel in the regular army.

SUMNER, WILLIAM GRAHAM, economist, was born at Paterson, N. J., Oct. 30, 1810. After graduating at Yale, 1863, he went abroad, and pursued his studies at Göttingen and Oxford. He was an instructor at Yale from 1866 to 1869. Having taken orders in the Episcopal Church in 1867, he went to New York, 1869, as assistant minister to Dr. Washburn of Calvary Church, and editor of *The Living Church*. After a brief season of pastoral duty at Morristown, N. J., during which he translated Lange's *Commentary on the Second Book of Kings* (1872), he was called back to Yale in 1872 as professor of political and social science. In this post he has been active and successful, inaugurating a special library for the use of his classes, and supplementing the immediate duties of his chair by frequent publications and continual contributions to periodicals. With great earnestness and cogency he protests against what he considers economic heresies of the day, and argues for the ideas he has adopted—free-trade, a gold standard, and the *laissez-faire* principle. His *American Finance* (1874), with other papers, was contributed to the *Transactions of the Social Science Association*. His chief publications are: *History of American Currency* (1874); *Lectures on the History of Protection in the United States* (1875); *Andrew Jackson in the American Statesmen series* (1882); *What Social Classes Owe to Each Other* (1883); *Economic Problems* (1884); *Essays in Political and Social Science* (1885); and *Protectionism* (1885). Having made large plans of work for some years to come, he has mainly suspended his activities outside the college.

SUMTER, THOMAS (1734–1832), major-general in the Revolution, was born in Virginia in 1734. He volunteered against the French in 1755, and was present at Braddock's defeat. He afterward removed to the upper part of South Carolina, and there fought with the Cherokees. On the outbreak of the Revolutionary war he was made lieutenant-colonel of riflemen, and was engaged chiefly against the Tories. After the capture of Charleston by the British, in May, 1780, Col. Sumter took refuge at first on the swamps of the Santa, and later in North Carolina. In July he returned and routed a force in the Catawba, killing both the British and Tory commanders. He was then made brigadier-general and, on Aug. 6, won another victory at Hanging Rock, but on the 18th was routed by Col. Tarleton. However, he continued to harass the enemy until late in November, when he was severely wounded. In the following February he resumed his operations, and co-operated with Marion until the close of the war. He was a member of the State convention which ratified the U. S. Constitution, and was elected to the first Congress under it. He served as a representative eight years, and in 1801 was chosen U. S. senator. Retiring in 1810, he resided on his estate, near Camden, S. C., until his death, June 1, 1832.

SUNDAY. See SABBATH.

SUNFLOWER, a common American plant of the order *Compositæ*, genus *Helianthus*, of which there are about fifty species in North America. The genus includes annuals and herbivorous perennials, with rough stems and foliage, some species bearing tu-

bers. The common Sunflower, *Helianthus annuus*, has a flat floral receptacle of from 6 inches to a foot and more in diameter. It bears



Sunflower.

showy yellow, marginal ray flowers, while the disk is crowded with brownish tubular ones. The prevailing idea that the Sunflower is so called from its presenting its floral disk to the sun is an error. It derived its name from its resemblance to representations of the sun with a circle of rays. The perennial species have much smaller and often very ornamental flowers. Some varieties are double, the disk flowers developing in the same form as the ray.

H. multiflorus produces in late summer double flowers which present a close resemblance to the dahlia, and are very ornamental for garden purposes. California has a species with very large double flowers, one of the best adapted to garden cultivation.

H. annuus is now cultivated in most parts of the world, being raised in some parts of Southern Europe as a field crop. The numerous large seeds which are borne closely crowded on the disk are useful as food for cattle and poultry, and yield a large percentage of excellent oil, little inferior to olive-oil. An acre of good land will sometimes produce 50 bushels of seed, yielding 50 gallons of oil. The American Indians make bread of the seeds. The flowers abound in honey and are much visited by bees, while the leaves are useful as fodder, and the stems, which yield much potash, are used as fuel. In some parts of Europe a bonilli is made of the seeds as food for infants. Sunflowers are supposed to destroy malarial conditions and prevent miasmatic fevers, and they are planted in many places for this purpose. The pith is used sometimes instead of the true moxa. Sunflowers are not cultivated largely for commercial purposes in America, and seem injurious to the soil from their large absorption of potash. One of the tuberous species is the well-known Jerusalem Artichoke, called Jerusalem from a corruption of the Italian word *girasole*, and Artichoke from the resemblance in flavor of its tuber to the true artichoke.

SUPERIOR, LAKE, is the highest and most northern of the chain of Great Lakes, and the largest body of fresh water in the world. The shape is somewhat triangular, with the apex turned toward the west. The length is 380 miles; the average width, 80 miles. The circuit is 1500 miles, and the area is 32,000 square miles. The elevation above the level of the sea is 627 feet, and the elevation above Lake Huron, the next lower in the chain of lakes, is 49 feet. The elevation above Lake Huron is shown in St. Mary's river, the outlet of Superior, where a series of rapids formerly obstructed navigation. But of late a ship-canal about the falls of St. Mary has given access to Lake Superior for the largest craft upon the lower lakes.

The basin of the lake is not as interesting as the basin of Lake Ontario, either as to geological or topographical features (see ONTARIO). Lakes Huron and Michigan lie in the basin of the Devonian lakes, while Green Bay, an arm of Lake Michigan, belongs to the lower Silurian lakes. What are known as the Niagara rocks turn eastward from Green Bay to the head of Lake Erie, closing a geological and hydrological circle around the peninsula of Michigan. This forms the Devonian basin above noted: and in a third basin, excavated from the same swales, and thrown to the east by the great anticlinal which connects Detroit and Cincinnati, lie the waters of Lake

Erie. If this anticlinal did not exist Lake Erie would have had no existence, Lakes Huron and Michigan would have emptied their waters through Georgian Bay into Lake Ontario, and no falls would have been known at Niagara. The narrow belt of Niagara rocks curving about the head of Lake Michigan contracts the water-shed so that it is but a short distance to the tributaries of the Ohio, Mississippi, and other rivers that empty into the Gulf of Mexico. The basin of Lake Superior lies apart from the basins of the other Great Lakes at the extreme north-western limits of the formations which have been mentioned. Its basin is excavated, in part, from the lowest of the Silurian rocks. The mineral resources, chiefly copper, iron, and silver, for which it is celebrated, belong to still older formations surrounding it on all sides except the southern. The Laurentian and Huronian mountains support a country of forests and lakes of great extent, all the waters of which reach the shores of Superior. The region is really the western end of the great northern basin drained by the Ottawa, St. Maurice, and Saguenay rivers. It is, indeed, a wilderness of small lakes, the areas of which would make a water-surface as extensive as that of Lake Ontario; and the aggregate of rivers would greatly exceed the volume of the St. Lawrence river. Lake Superior, upon the American side, is somewhat low and sandy, the monotony of the shore being broken by the Pictured Rocks; but upon the Canadian side the banks are less uniform. Among the islands the Twelve Apostles, Isle Royale, and Grand Isle, belong to the United States; and the Silver, Montreal, Leech, Slate, St. Ignace, Pic, Sandy, Caribou, and smaller islands belong to Canada.

Lake Superior appears to have been comparatively free from the greater part of the fluctuations in the height of water that have been noticed upon the lower of the Great Lakes. On April 14, 1858, there was reported a change of 6 feet in the level of Lake Michigan. On May 10, 1823, according to De Witt Clinton, at Otter creek, on the Canada shore of Lake Erie, a wave came in 9 feet high, and the same occurrence took place at Kettle creek, 20 miles distant. Another, in 1830, reported 3 waves at Madison Rock, Lake Co., Ohio, the first rising 15 or 20 feet. In 1844, or 1845, a wave came into Euclid creek 15 feet in height, carrying everything before it. On Nov. 15, 1845, the water at Cleveland suddenly fell 2.8 feet during a high wind from the southwest. The U. S. government has, since 1859, taken 3 observations daily of the height of the water at the Milwaukee lighthouse. In May, 1887, the water in Milwaukee bay was a foot lower than in May, 1855. In September the water reached the highest level it had attained since 1859, a period of 27 years. In 1876, however, the water-level was very high, though not as high as in 1856. The lowest stage of the water recorded was in February, 1873, when the water-level was 4 feet below the level of 1833. The annual flood tide of the water is in September and October, and the annual ebb tide in January, February, and March. The greatest difference in the water-level noted in one year was in 1871, when it was 2.6 feet higher in the fall than in the previous winter. Before 1859 the observation of the water-stages depended upon private sources, and they are conflicting. In 1852 Solomon Juneau, who had resided in Milwaukee since 1818, said that never in his recollection had the water in the bay been so low as in 1820, and never so high as in June, 1838, when the old Indian race course was 6 feet under water. The difference between the water-stage of 1819 and that of 1838 was 4.8 feet at Milwaukee and 5 feet 3 inches at Detroit. This proves that Lake Michigan annually rises and falls from 12 to 18 inches. Lake Superior also shows fluctuations in a less degree. In 1789, opposite Isle

Royale, there was a sudden fall of four feet in the waters, and when they returned they did so with a rush, the vibrations continuing for several hours. In 1834 the waters above the Sault St. Mary rapids suddenly receded, and in half an hour returned with great velocity. In August, 1845, Dr. Foster states that while in an open boat between Copper harbor and Eagle river, an enormous surge, 20 feet in height and crested with foam, rolled toward the shore, succeeded by 2 or 3 swells. Dr. Foster observed repeated flows and reflux of the waters in 1847, 1848, and 1849, which preceded or followed storms on the lake. In 1851 D. D. Brockway reported, in a perfect calm, a sudden rise of 15 inches, and in another 2½ feet. The *Lake Superior News* of July 17, 1855, reported extreme fluctuations between 9 a. m. and 4 p. m. The U. S. government has recently finished several charts, based upon a long series of observations, which show that from 1882 to 1888 the surface of Lakes Michigan, Huron, and Erie was considerably above the mean level. The water at the present time is about one foot lower than the average from 1882 to 1887. The charts also show that the fluctuations in the lake levels have closely corresponded to the rainfalls. The fact may be considered established that the Lakes are simply great pools, forming part of the course of a river, and that they conform to all the laws governing the rise and fall of rivers.

As early as 1621 it was known that the shores of Lake Superior contained great mineral wealth. The French Jesuits first visited the great inland sea early in the beginning of the 17th century, but it was not till nearly fifty years later that René Mesnard visited the Lake and wrote an accurate account of the discoveries made on his voyage about its shores. Mesnard was followed by Allouez, Marquette, Dablon, and other French explorers, who made good maps of the lake, and gathered much information about the minerals from the natives with whom they came in contact. In 1721 De Charlevoix, an adventurous Frenchman, spent nearly a year on and about Lake Superior, and a few years later he published a graphic account of his discoveries in Paris. During the 18th century a number of explorers and trappers visited the shores of the Great Lakes, and while all of them seem to have formed a high opinion of the mineral wealth of the shores of Superior, the great distance from what was then the boundary of civilization made it impossible to operate mines of any kind. One English company, formed to mine copper, did send, in 1770-72, a few men to the north of Ontonagon river, but no copper was ever mined by them. In 1830 Dr. Douglas Houghton, an able geologist, visited the Lake Superior district in company with Gen. Lewis Cass, and continued his explorations for 10 years, spending nearly all of that time in northern Michigan. In 1841 he made a report to the State legislature setting forth his discoveries. The report made a sensation, and led to the development of the great copper interests of the district. In 1845 Dr. Houghton was drowned in L'Anse bay, and with him perished much valuable knowledge. In addition to discovering valuable veins of copper, it is certain that he found gold in nuggets and grains. His death was a great loss to the district. Since 1842 the development of the copper mining industry has been rapid and continuous (see COPPER).

In 1845 what the discoverers thought to be a solid mountain of iron ore was found at Neganec, Marquette Co., and the Jackson Iron Company was formed to mine and smelt the ore. From 1845 to 1855 very little was accomplished, but in the latter year the first canal at Sault St. Mary was completed by the State, and it became possible to ship ore to Eastern furnaces. In 1854 the old Cleveland mine

in Ishpeming sent a small cargo of ore to the Pennsylvania furnaces, and the Jackson mine had made several small shipments in previous years. In 1858 the Lake Superior, and in 1864 the Lake Angelina, mines were added to the list of producers; and since 1835 new mines have appeared each year on the list of shippers. In 1877 the first ore was shipped from the Menominee range, and in 1884 small shipments were made from the Gogebic and Vermilion iron range mines. Out of a grand total of 35,559,000 tons of iron ore shipped from the entire Lake Superior district since 1854 the Marquette county mines have furnished 25,149,603 tons; and of this amount four mines (the Cleveland, Jackson, Lake Superior, and Republic) have furnished over one-half. The Lake Superior is the largest iron mine in the world, with the Cleveland second.

The grain of the great Northwest has, of late years, sought an outlet to market through the harbor of Duluth (*q. v.*), the eastern terminus of the Northern Pacific Railway. The city, which now contains about 10,000 inhabitants, is upon a bay which has been artificially protected by 2 miles of breakwater. The early commerce of the Lake was conducted in small schooners whose capacity seldom exceeded 10 tons. The largest vessel in 1818 had a capacity of 133 tons. In 1852 the commerce of Lake Superior had increased to such importance as to necessitate the improvement of the St. Mary's river. The improvement included the digging of a canal, with locks, around the Sault St. Mary. The locks were sufficiently deep to pass vessels drawing 11 feet of water. In view of the possible increase of commerce on the upper Lake there was sufficient area between the gates of the locks to admit several vessels at once. It was supposed that this lock (opened in 1855) would accommodate the future traffic of Lake Superior, but in less than 10 years it could not accommodate the increasing traffic. Another lock was constructed, 515 feet long and 80 feet wide, and with 17 feet of water on its mitre-sills. It was opened for traffic in 1881. The maximum capacity was 96 vessels per day. The new lock of the canal, constructed on the site of the original canal, is 800 feet wide, and it has 21 feet of water on the mitre-sill.

The life of the lake traffic is the up-cargo, which uniformly consists of coal. This product is brought to Buffalo from the anthracite mines of Pennsylvania, and to Toledo and Cleveland from the bituminous mines of Ohio. This furnishing of coal for up-cargoes gives the Americans a great advantage over the Canadians; and the latter, after spending many millions to draw the trade of the upper Lakes to Montreal through the Welland and St. Lawrence canals, have failed to divert it because their products are chiefly imported goods not necessary to the life of miners and grain-growers. The enlarging of the St. Mary's canal has resulted in the building of a much larger class of vessels than it is possible to pass through the two Canadian canals.

A grain-boat, launched in 1887, draws, when empty, about 5 feet of water, and cost \$300,000. It is a three-decked steam-ship with a hull of steel, propelled by compound engines. The ship carries 2,800 tons of cargo and fuel on a draught of 15½ feet, and with this load will run 16 miles an hour. The length over all is 357 feet; depth, 25½ feet; beam, 41 feet. An iron or steel steamer of ordinary size, strong and seaworthy, and with great towing power, to carry 75,000 bushels of wheat and tow 3 consorts, costs about \$175,000. A wooden screw steamer, of the same carrying capacity and towing power, costs about \$125,000. A wooden schooner to carry 75,000 bushels of wheat, or 2150 tons, costs about \$75,000. A steel steamer and four consorts, as now built, represent about \$475,000. The five ships carry the wheat that grew on 22,000 acres of productive wheat land in

Dakota. This amount is sufficient to load 24 freight trains of 30 cars each, and each car carrying 500 bushels, and it would load nearly 50 canal-boats. Wheat can be carried by this method from Duluth to Buffalo, a distance of 880 miles, for 3 cents per bushel; and this rate is profitable if an up-cargo can be secured. The statistics for the close of the season of 1888 show that 6,500,000 tons of freight had been carried through the St. Mary's canal since the opening of navigation, a gain of 1,000,000 tons or more over any former year. Thus in six months (the season of navigation) as much freight was taken over this fresh-water route as passed through the Suez canal in twelve months. The average distance this vast quantity of ore, coal, wheat, flour, and other freights is carried by the vessels in which it passes through the canal at St. Mary's is estimated to be not less than 600 miles. This makes a total freight movement equivalent to the transportation of 3,900,000,000 tons one mile, for the whole season of navigation. In 1887 the entire freight business of all the railroads of New England was equal to the transportation one mile of 2,141,588,000 tons. The tonnage of all the railroads in the two Carolinas, Florida, Mississippi, Arkansas, Colorado, Oregon, and Georgia may be added before the total reaches the volume of traffic from Lake Superior through the St. Mary's river in six months.

(F. G. M.)

SUPPE, FRANZ VON, Austrian musician of Belgian descent, was born at Sjalato, Dalmatia, April 18, 1820. He was educated at the University of Padua, studied music at Vienna, and became a conductor at Presburg, but afterward removed to Vienna. He has composed many masses, symphonies, and quartets. Of his overtures, *Dichter und Bauer* is the best known. He has also composed many operas, including *Das Mädchen vom Lande* (1847); *Franz Schubert* (1864); *Schöne Galatea* (1865); *Freije* (1866); *Isabella* (1869); *Fatinitza* (1876); *Boccaccio* (1879); *Donna Juanita* (1880). *Fatinitza* has been produced in England and America.

SURGERY, AMERICAN. The history of surgery in America begins during the latter half of the last century. Before that time there were capable practitioners, men of great vigor and originality of

thought, and large practical wisdom, but there were none who could be classed as surgeons, certainly no great surgeons. The medical men of one hundred years ago were those who first gave distinction, in the eyes of the civilized world, to the teaching and practice of surgery on this continent, and the history of surgery is really the history of their lives and achievements. Sydney Smith asked, in No. lxx. (January, 1820) of the *Edinburgh Review*, "What does the world yet owe to American physicians or surgeons?" Even at that date the question was one which could have been answered with pride by anyone familiar with the records of surgery in America, and at the present day the briefest enumeration of the valuable additions to surgical knowledge made by American surgeons would far exceed the limits of this article.

In the last half of the eighteenth century there flourished in America a number of distinguished men whose names are now familiar to surgeons throughout the world. Chief among these was Dr. Benjamin Rush, who, although he did not perform any great surgical operations, had acted as surgeon-general to one of the divisions of the Revolutionary army and had left in that capacity a most creditable record. In those days, as at the present time, medical men in America occupied the highest social rank. Dr. Rush, with others of his professional contemporaries, left his mark not only upon the surgery and medicine of that period but upon the general

literature, the politics, the philanthropy of the day. His influence was so wide-spread, his practice so extensive, and his skill in all departments of medical science so great, that his name naturally begins the list of great American practitioners; but his contemporary, Dr. John Jones, also a Philadelphian, was perhaps at the same period the best known surgeon of the country. He was a pupil and friend of Mr. Pott, a physician to the Pennsylvania Hospital, and vice-president of the College of Physicians. He wrote one of the first American treatises on surgery, which was published about 1777. He was an expert operator, particularly in cases of stone, which he extracted with great rapidity, a more important matter in those days than in these of anæsthetics. He is said to have performed the first operation of this kind in America in 1790. He attended Dr. Franklin, who suffered with stone in the bladder, and was the family physician of Washington.

Philip Syng Physick, the pupil of John Hunter and a professor of surgery in the University of Pennsylvania at the beginning of this century, earned the title of "The Father of American Surgery" by his admirable teachings and his skilful work as an operator. One of his most noted operations was that upon Chief Justice Marshall, from whom, when he was at an advanced age, he removed upward of one thousand vesical calculi. Dr. Physick originated a process of employing animal ligatures, selecting for the purpose dog-skin cut into suitable strips and then rolled on a marble slab to impart to them the requisite degree of hardness, roundness, and smoothness. Dr. John Syng Dorsey, after numerous experiments performed at the instance of Physick, was led to employ for this purpose French gut, using it in various amputations and in a number of capital operations, cutting the ends off close to the knot and treating the wound as if no ligature had been used. He was professor of anatomy in the University of Pennsylvania, and was the first surgeon in the United States who ligated the external iliac artery. Dr. William Gibson, who held the chair of surgery in the same institution, was the first surgeon who ever tied the common iliac artery. At about the same time lived Dr. John C. Warren, a son of Dr. John Warren, who was the surgeon-general during the Revolutionary war and professor of anatomy and surgery in Harvard College. He performed the first successful operation for the relief of dropsy of the pericardium, drawing off the accumulation of fluid with a trocar and cannula. The younger Dr. Warren succeeded his father in the joint professorship at Harvard, and was the first surgeon who ever gave ether as an anæsthetic during a surgical operation.

Dr. John Rhea Barton invented the well-known operation for the treatment of ankylosis, having performed excision of the hip on a sailor in 1826, described a fracture of the lower end of the radius still known by his name, introduced the bran dressing in the treatment of fractures and dislocations of the leg, and devised the bandage known by his name and employed in fractures of the lower jaw.

Dr. Valentine Mott, of New York, was the first surgeon who ever tied the innominate artery, but his reputation rests upon a long series of brilliant and successful operations. Dr. Gross says of him: "No surgeon, living or dead, ever tied so many vessels, or so successfully for the cure of aneurism, for the relief of injury, or the arrest of morbid growths." The catalogue, inclusive of the celebrated case of the innominate artery, comprises 8 examples of the subclavian artery, 51 of the primitive carotid, 2 external carotid, 1 common iliac, 6 external iliac, 2 internal iliac, 57 femoral, and 10 popliteal—in all, 138.

Dr. Ephraim McDowell, of Kentucky, was the first ovariectomist of the world, and shared with all other

great discoverers the universal opprobrium and bitter criticism of his fellows. He was also one of the most successful lithotomists of the early part of this century, attaining very enviable success in the lateral operation for stone.

The first ligation of the primitive carotid artery was performed in this country by Dr. Amos Twitchell, in 1807, some time before the famous case of Sir Astley Cooper, which was supposed to be the first of its kind on record.

In the treatment of ununited fracture, various improvements were made by American surgeons, notably the introduction of the seton by Dr. Physick, the union of the ends of the fragments by a metallic pin or screw as practised by Dr. Joseph Pancoast, and the freshening and wiring of the extremities as done by Dr. Rodgers, of New York. Dr. Reid, of Rochester, demonstrated by a series of dissections and experiments the possibility of reduction of dislocations by manipulation and by dispensing with the cumbersome and sometimes dangerous appliances which had been used for that purpose. His paper on this subject was followed by others by Prof. Gunn, of Chicago, and Moore, of Rochester; and, still later, by a comprehensive monograph by Prof. Bigelow, of Harvard.

The first operations for the relief of ankylosis of the inferior maxillary were performed by Dr. Carnochan, of New York, and by Dr. S. D. Gross, of Philadelphia.

Among the brilliant surgery of the century, we can only briefly record the operations of Dr. J. Kearney Rodgers, for ligation of the left subclavian between the scalene muscles; of Hunter McGuire for ligation of the abdominal aorta; of Onderdonk for ligation of the femoral in arthritis of the knee; for extirpation of the clavicle by Mott. The inventions or modifications of splints by Physick, Hodgden, N. R. Smith, and others were of the highest practical importance, while Fox's apparatus for fracture of the clavicle is yet in common and effective use. Dugas, of Georgia, pointed out one of the most valuable diagnostic signs of scapulo-humeral luxations, and Bigelow, in the paper above mentioned, revolutionized the theory of the mechanism of dislocation of the hip. Dr. Joseph K. Swift, of Easton, Pa., was the first surgeon to employ adhesive plaster as a means of extension in fractures of the lower extremities, an enormous step in advance, both as to comfort of patients and practical results obtained.

The employment of rest in general affections, which has recently been insisted on with great vigor by numerous European writers, was taught and practised in this country one hundred years ago by Dr. Physick. Trephining for bone abscess, usually credited to Sir Benjamin Brodie, was first performed by Nathan Smith, of New Haven, in the latter part of the 18th century. The first excision of the upper jaw ever performed was done by Dr. Jamison, of Baltimore, and the first resection of both bones by Dr. Rodgers, of New York. Dr. J. Mason Warren, of Boston, was the first to suggest the importance of dividing the muscles in the arches of the palate as a means of facilitating the union of the edges of the fissure after operations for cleft palate. Dr. Milton Antony in 1823 published, in the *Philadelphia Journal of the Medical and Physical Sciences*, a case in which he removed, along with a diseased rib, a large portion of lung-tissue which was involved. The drainage of the bladder through the perineum in case of chronic cystitis suggested by Mr. Guthrie, of London, was first put into practice by Prof. Willard, of New York.

The most important advance in the surgery of the urinary organs made within the century was introduced to the profession by Dr. Henry J. Bigelow of Boston, in January, 1878. Until that time it had been

the custom to greatly limit the period during which crushing operations were carried on, several sittings being necessary before the operation was completed, the maximum time of 8, 10, 15, or 20 minutes being allowed by various surgeons for the crushing of the stone. Dr. Bigelow showed that with proper care and gentleness the crushing could be completed at one sitting, even when it required several hours to effect this, and that at the same time the whole mass of debris could be evacuated instead of being left in the bladder to pass out with the urine. Dr. Bigelow greatly improved the lithotrite in several important particulars and invented an evacuating apparatus far superior to anything previously employed. His discovery was greatly facilitated by the observation of Dr. Fassenden Otis, of New York, who had previously shown that the calibre of the male urethra was far greater than had been supposed, and that catheters and bougies of much larger size than were formerly employed could be used with entire safety.

Extirpation of the coccyx for what was then known as coccygeal neuralgia was first done by Dr. J. C. Nott, of Mobile, although later Sir Joseph Simpson, not knowing of Nott's essay, described the same disease under the name of coccygodynia, and advocated the same method of treatment. J. Marion Sims in 1832 introduced to the medical world his operation for vesico-vaginal fistula, which has from that day to this maintained its position as an operative procedure and has perhaps done as much to restore to health and happiness large numbers of suffering women as any other operation in the entire domain of gynecology. The relief of chronic cystitis by permanent drainage of the bladder should also be accredited to the inventive genius of Sims, although at about the same time the same procedure was employed by Nathan Bozeman and Thomas Addis Emmett. Parvin's operation for the cure of urethro-vaginal fistula, the so-called Batey's operation, and the operation of gastro-clytrotomy, have all been either originally conceived or greatly improved by American surgeons. While considering the department of surgery known as gynecology, mention should of course be made of the forceps and the lever-pessary of Hodge, and the speculum, uterine repositor, and probe of Sims.

In ophthalmic surgery should be mentioned the ingenious method of advancement of the lateral eye-muscles devised by Dr. A. E. Prince. This has received very wide adoption. A number of modifications of the various plastic operations upon the lids have appeared from time to time in the hands of American surgeons; notably Green, of St. Louis.

The method devised by the late Dr. C. R. Agnew, of New York, for removing a lens dislocated into the vitreous, with the aid of a bident, deserves mention; as do the able experimental researches of Knapp, of New York, and Weeks, of New York, in antiseptic eye-surgery; the discovery of the bacillus of acute conjunctival catarrh by Weeks, and his useful investigations of the bacteriology of xerosis conjunctiva. The three best ophthalmoscopes which have emanated from American inventors since the introduction, years ago, of Dr. Leaning's instruments, are those devised by Randall, Jackson, and Kelsey, of Philadelphia.

Medical teaching was even during the last century, in certain parts of the Eastern and Middle States, to be favorably compared with much of the instruction given at European schools. At the University of Pennsylvania, the centre of American medical education at this time, or connected with the Pennsylvania and Philadelphia hospitals, were to be found during the early years of this century many of the men whose names are still familiar to the profession throughout the world: John Syng Dorsey, Nathaniel Chapman, W. P. Dewees, Robert Hare, Samuel Jack-

son, Isaac Hays, Hugh Hodge, John Rhea Barton, Geo. B. Wood, William W. Gerhard, William Pepper, Sr., George W. Norris, and others whose teachings and writings have in no small degree aided in the progress of medical science. It would have been pleasant to point out in detail the work of each of those gentlemen; to dwell on the remarkable and diversified talents displayed by Dorsey, whose death at the age of thirty-five, just after his election to the chair of anatomy in the university, removed one of the most promising teachers ever seen in Philadelphia. He is said to have lectured on operative surgery, given practical instruction in *materia medica*, demonstrated anatomical details in the dissecting-room, and examined in physiology in the same day, with equal satisfaction to his pupils. We are indebted to Dr. Chapman, not only for innumerable *jeux d'esprit* and for brilliant medical teaching, but for the establishment in 1820 of the best medical periodical in America, if not in the world, *The American Journal of the Medical Sciences*, afterward so ably edited by the Drs. Hays, father and son. The first number bore on the title-page the quotation from Sydney Smith already alluded to. A special edition of this journal, with a single exception the oldest medical periodical in the English language, is now published in London for the benefit of British readers. To Dr. Gerhard belongs the honor of having been the first to point out clearly the distinction between typhus and typhoid fever, a differentiation which has saved thousands of lives. Much well-deserved praise could be written of the contributions of Barton to mechanical surgery and of his original operation for the cure of bony stiffening of the joints, the parent of all the orthopaedic and subcutaneous surgery of the present day; of the advances made by Norris in conservative surgery; of the rare diagnostic acumen and brilliant clinical abilities as teacher and practitioner of the elder Pepper; of Wood's great labors in practical medicine and therapeutics, his undying record still existing in what is probably the most successful medical book ever published, *The United States Dispensatory*. John K. Mitchell's inquiries into the absorption of fluids and the origin of malaria were markedly in advance of their day, in some respects almost prophetic, while Hodge's invention of the lever-pessary, and Hare's of the oxy-hydrogen blow-pipe, cannot pass unnoticed. Dr. Gross, in his recently published autobiography, has given us a list of his contributions to medical science, a list of which any surgeon, or, indeed, any two or three surgeons, might be proud; but his researches on wounds of the intestines deserve special mention.

In 1824 the Jefferson Medical College, which was in its origin an offshoot of the University of Pennsylvania, was founded by Drs. McClellan, Eberle, Kleebs, and Green, all graduates of the university, and in 1825 and 1826 the first course of lectures was given. A number of distinguished men have been connected with it from that day to this, notably Mutter, the founder of the Mutter Museum and lectureship at the College of Physicians; John K. Mitchell, the father of Dr. S. Weir Mitchell; Joseph Pancoast, Charles D. Meigs, J. M. Da Costa, and Prof. S. D. Gross.

It seems hardly possible, and is perhaps hardly proper, in this article to enter with any detail into the history of more recent achievements by American surgeons. The earlier work of Dr. D. Hayes Agnew, in the improved operations upon vesico-vaginal fistula and of lacerated perineum, was most brilliant, and his teachings have had a lasting influence as regards those operations, while his work as a general surgeon has probably never been surpassed either as regards the ground covered, the results obtained, or the sound judgment displayed. The

work of Dr. S. Weir Mitchell, in reference to the results of injuries to nerves, constituted a new departure in the study of the pathology of these structures, and the results have been of vast importance to the practical surgeon. The work of the same physician in the investigation of the nature, results, and treatment of snake-bites also has been of the highest value. The statistical work of the younger Gross, the observations of Otis upon the capacity of the male urethra, which rendered possible the introduction of litholapaxy by Bigelow, the experiments of Senn, of Milwaukee, upon wounds of the intestines and intestinal sutures, the monumental labors of the compilers of the *Medical and Surgical History of the War of the Rebellion* and of Dr. Billings and his associates in the preparation of the *Index Catalogue* and *Index Medicus*, and the equally noteworthy work of many others who cannot be mentioned here, serve to illustrate the fact that American surgery to-day is as worthy of respect and admiration as at any period in the history of the country.

Perhaps the four great achievements of the century have been the introduction of anesthesia; the establishment of ovariotomy as a justifiable procedure, the outcome of which has been modern abdominal surgery; the elevation of gynecology into a science; and the recognition of the principles of antiseptic surgery. When we remember that of these four the first three are clearly attributable to American genius and skill, and that nowhere in the world was the inestimable value of the fourth earlier appreciated than in this country, we can understand the debt which the civilized world owes to American surgery.

In the limits of this article the merest allusion to the most memorable occurrences has been possible, but much more of almost equal interest and importance may be found recorded in the *Essays of Professors Gross and Thomas* which may be found in *A Century of American Medicine*, published by Lea, of Philadelphia, in 1876. (j. w. w.)

SWAYNE, NOAH HAYNES (1804-1884), jurist, was born in Culpepper Co., Va., Dec. 27, 1804. While an apothecary's clerk at Alexandria he entered on a course of higher study, and was admitted to the bar at Warrenton, Va., in 1824. He then removed to Coshocton, O., and in a few years was elected to the State legislature. He was U. S. district attorney from 1830 to 1839, and in the meantime was elected judge of the county court, but declined. In 1836 he was again elected to the legislature, and there took a prominent part in organizing State asylums for the insane, blind, deaf, and dumb. His eminence in his profession induced Pres. Lincoln to appoint him a justice of the U. S. Supreme Court in January, 1862. He resigned this profession in 1881 on account of his advanced age, and died in New York City, June 8, 1884.

SWINBURNE, ALGERNON CHARLES, English poet and critic, was born at Pimlico, a suburb of London, April 5, 1837. He is the son—the eldest of six children—of Admiral Charles Henry Swinburne, R. N., and of his wife, Lady Jane Henrietta, daughter of the third Earl of Ashburnham; and the grandson of Sir John Edward Swinburne, Bart., of Capheaton, Northumberland. From the blood and influence of the latter, a man of no common mould, who lived and retained his natural force unabated to the extreme age of ninety-eight, the poet has evidently derived much that is characteristic in him. As a boy, young Swinburne's tastes ran on the one hand to poetry, and on the other to swimming and riding. In these physical exercises he is said to have excelled. He was not merely a great reader of poetry, but of poetry of a very high order of excellence. In one of his books he speaks of "having, from well-nigh the first years I can remember, made of the

study of Shakespeare the chief intellectual business, and found in it the chief spiritual delight of my whole life." Poets and authors of the first rank exerted a most powerful influence on the impressionable mind of the lad when he was, to use his words, "most susceptible of influence, and least conscious of it, and most in want." As a child, he often found an all-sufficient delight in the mere music of verse the meaning of which was quite beyond his power of comprehension. His memory for poetry was specially retentive. His favorite authors so impressed themselves on his mind, apparently with little or no direct effort on his part, that he early had by heart long passages from them—even entire poems. As was most natural in a lad so constituted, efforts at original composition of poetry soon followed, and some of these boyish effusions he afterward published in his somewhat notorious collection of *Poems and Ballads*.

Young Swinburne was sent to Eton, and after five years there entered Balliol College, Oxford, as a commener, in 1857. While at the university he was one of the chief among some half-dozen student contributors to a short-lived college magazine, *Undergraduate Papers*. His contributions included, among other things, what was considered a very clever parody. After something less than four years at Oxford, he left the university without taking a degree. He was, however, a natural scholar, and his attainments, especially in literature and the languages, have been considered—and justly—as truly phenomenal.

Without ever having personally met Walter Savage Landor, at that time England's oldest living poet, young Swinburne came to entertain for him the most enthusiastic admiration and regard, and in 1864 he made a veritable hero-worshipper's pilgrimage to Italy, for no other purpose than to make the personal acquaintance of his hero. The aged poet received him cordially, and the two spent some months together at Florence, during the last year of Landor's life.

After previous publications, not without merit, Mr. Swinburne first achieved name and fame by the publication, in 1865, at the age of twenty-eight, of his classical drama, *Atalanta in Calydon*. *Atalanta* is a tragedy upon the severest Greek model—certainly a unique, and by many considered an almost faultless, work of art. It was the result of a happy inspiration, born of prolonged training in the classical languages. Nor is it a mere Greek imitation; it is rather the product of a Greek imagination. Hence *Atalanta* ranks with the very best productions of its kind. Seldom or never has it been given to an author to achieve popularity by the publication of a work which naturally appeals to so restricted an audience. Yet it would not be wide of the truth to say that Mr. Swinburne did achieve just that—over and above the reputation he gained within the world of letters. Few modern resuscitators of the ancient classical drama have more nearly contrived to "make the dry bones live."

But while *Atalanta* made the young author famous, *Poems and Ballads*—published the following year—in this country under the title of *Latus Veneris*—came very near making him, in certain eyes at least, infamous. The book was violently assailed as being grossly sensual and immoral. Parts of the collection were declared to be indecent, others blasphemous. In defence of the work the plea has been urged that the poems were, as Mr. Browning says of a volume of his own, "though lyric in expression, always dramatic in principle, and so many utterances of so many imaginary beings." But many who accepted the plea refused to consider all parts of the work as artistic in the best sense. Still others, who entertained a high opinion of the young

author, both as an artist and as a man, admitted that in the selection of some of his subjects he had been injudicious and unfortunate. The outcry against book and author was so sudden, sharp, and emphatic, that his publishers, the Messrs. Moxon & Co., withdrew the book almost immediately from circulation. It was reissued with little delay, however, by another publisher, at whose instance, and in whose behalf, Mr. Swinburne published a brief reply to his assailants, *Notes on Poems and Reviews*, in the course of which he says: "The book is dramatic, many-sided, multifarious, and no utterance contained therein can properly be assumed as the assertion of the author's personal feeling or faith. . . . If literature indeed is not to deal with the full life of man and the whole nature of things, let it be cast aside with the rods and rattles of children. Whether it affects to teach or to amuse, it is equally trivial and contemptible to us; only less so than the charge of immorality. Against how few really great names has not this small and dirt-encrusted pebble been thrown. . . . I knew that belief in the body was the secret of sculpture, and that a past age of ascetics could no more attempt or attain it than the present age of hypocrites."

Mr. Swinburne was not content to be known and criticised as a poet. He turned critic himself, and discussed all sorts of literary and artistic subjects in the current reviews. His prose work materially enhanced his reputation in certain quarters, while much of it also has been sharply criticised and even ridiculed.

Although the immediate descendant of two very old and exclusive families of the English aristocracy—himself barely without the pale of the titled aristocracy, and only through the operation of the English laws of primogeniture—Mr. Swinburne early espoused the most radical opinions politically, and sought by his pen to promote the cause of republicanism in Europe. In *A Song of Italy* he apostrophizes—almost to apotheosis—Garibaldi and Mazzini. His republican ardor and hopes for the future found still further expression in the *Ode on the Proclamation of the French Republic*, the *Songs before Sunrise*, and the *Note of an English Republican on the Muscovite Crusade*.

In 1871 Robert Buchanan, the poet, published in one of the reviews, under the assumed name of "Thomas Maitland," an article, "The Fleshly School of Poetry." This was aimed more especially at Mr. Dante Gabriel Rossetti, but in the acrimonious discussion which ensued Mr. Swinburne—a warm personal friend of Rossetti's and classed with the latter, by Mr. Buchanan, in the obnoxious "Fleshly School"—became involved, and published a reply (to Mr. Buchanan) entitled *Under the Microscope*. In the course of this paper he also gave expression to some of his opinions respecting American poets and poetry. Poe and Whitman were singled out as deserving of high commendation, but most of their fellow-craftsmen in America were characterized as "mocking birds," or, where really independent of models, as "corn-crakes"—because of the harshness and worthlessness of their song.

Eveithens is a second classical drama. It is generally regarded as inferior to *Atalanta*. The *Note on Charlotte Brontë* is a brochure full of enthusiastic and exalted praise of Miss Brontë, in which the gifted author of *Jane Eyre* and her sister Emily are rated with Mrs. Browning, and far above George Eliot, George Sand, and other women in the world of letters. *A Year's Letters by Mrs. Horace Manners* is Mr. Swinburne's first and thus far his only effort in the field of prose fiction.

Mr. Swinburne has shown a most remarkable power of imitating the characteristic style of other poets of various ages and countries. *The Heptalogia*

was an anonymous imitation of Tennyson, Browning, and others; himself included, the better to divert suspicion from him as the author. But though the authorship in this case did not remain undiscovered, some work of this sort by Mr. Swinburne has deceived the very elect among the critics. *Chastelard*; *Bothwell*; and *Mary Stuart* form, together, a dramatic trilogy on the Scotch Queen, whom Swinburne condemns for reasons peculiarly his own. *Marino Faliero* is certainly superior to Lord Byron's tragedy of the same name.

Swinburne's rightful place among the poets is the subject of wide—almost violent dispute. While some regard him as an unintelligible "language-slinger"—an insatiable word-monger—others, conceding his poetic genius, deplore the sensuous tone of his muse. A poet of acknowledged power has said that in all his many volumes "he has written no line that lingers in the memory, has uttered nothing that resembles a thought;" which has been indorsed by a reviewer in the sentence: "A severer criticism could not be conceived and a truer one its author never uttered." On the other hand, judges are not wanting who rate Swinburne not merely among the poets of high rank, but who assign him a high position in that select coterie. Among his defects may be mentioned, first, a fatal facility for the selection of unfortunate if not positively inartistic themes—themes that to a vast majority of cultured people are physically or morally repulsive, if not both: second, an inability to exercise true artistic restraint—extravagance in the treatment of his subjects—overdoing, generally, in what he says and in his way of saying it: third, a readiness to subordinate, if not actually to sacrifice, sense to sound, to rate formal execution of greater import than insight, the outcome of which tendency is to render his poetry often mere word-music devoid of sufficient thought to vitalize it: fourth, a proneness to be vague, indefinite, unintelligible—nay more, to be at times positively inane. Beyond this, severer critics assert that he is a man so wrapped in a self-limited world that he is constitutionally incapable of broad human sympathies. This want of community of feeling with his fellows is shown by the slight tendency of his poetry to find lodgement in the minds and memories of men. "By necessity, proclivity, delight, men quote," and from none more freely than from the great writers of all time—whether Biblical, classical, or modern—yet mankind are not given to quoting Swinburne. However learnedly some men argue about him, however prone some are to praise him, they are slow to quote him. Prolific as his pen has been, it has added next to nothing to the deathless and divine in literature which graves itself at once and indelibly on human hearts and memories. And in proportion as this point is well made, it would seem to argue some vital defect in him as a man, and consequently as an artist, which must ever exclude him from the circle of the world's great poets.

As for his merits, his champions aver that all his work, prose as well as poetry, evinces a knowledge, vast and varied, of the world's best lore; an eager and passionate love of beauty; an enthusiastic devotion to art for its own sake; an impetuous, luxurious, and wholly distinctive individuality of style; a quickness to perceive and a readiness to praise everything in the work of his fellows that seems to him meritorious; a lofty artistic *hanteur*—an implicit belief in himself which, however egotistic it appear to the vulgar crowd, has always been, still remains, and must ever continue a prime requisite of Genius.

They call attention, in his verse, to his facile alliterations, to his pleasant surprises in metre and rhythm, to the originality and scope of his melodious variations; to his curiously intricate stanzaic forms, all singularly felicitous in their ever-recur-

ring assonances and concordant sounds. Nor will they admit that his poetry is merely exquisite sound. They find it as full as adverse critics find it void, of suggestive and valuable thought. They dote on his "marvellous execution," his "wonderful technique," but assert that these powers are but superadded to that of vitalizing his verse with a substance of thought worthy of the lyric splendor shown in its construction. To them his strains are as subtly strong as they are surpassingly sweet. He is a sovereign among rhythmists—in all moods an absolute autocrat of verse.

Whatever may be our conclusions about Swinburne, it is certainly long since any man in the literary world has provoked discussion more varied, more extended, more unintermitting. For wellnigh a quarter of a century he has been a most prominent figure among contemporary men of letters. Writing not for gain, but simply and solely to please himself, following unflinchingly his own star, whithersoever it might take him, refusing to yield so much as a single article in his artistic code, to gain a friend or to placate a foe, he has produced a mass of work which, good or bad, is undeniably original and characteristic, and from which neither his brother artists, nor the camp-following critics, nor the hosts of the philistines have been able successfully to avert their gaze. He is a man whom his admirers are unable to sufficiently praise, and whom his detractors treat with all manner of contempt, save the supreme contempt of silence and neglect.

Swinburne's collected works comprise: *The Queen Mother and Rosamond* (two plays, 1864); *Atalanta in Calydon: a Tragedy* (1865); *Chastelard: a Tragedy* (1865); *Poems and Ballads* (1866); *Notes on Poems and Reviews* (1866); *A Song of Italy* (1867); *William Blake: a Critical Essay* (1868); *Siena: a Poem* (1868); *Ode on the Proclamation of the French Republic* (Sept. 4, 1870); *Songs before Sunrise* (1871); *Under the Microscope* (1872); *Bothwell: a Tragedy* (1874); *George Chapman: a Critical Essay* (1875); *Essays and Studies* (1875); *Songs of Two Nations* (1875); *Erechtheus: a Tragedy* (1876); *Note of an English Republican on the Muscovite Crusade* (1876); *A Note on Charlotte Brontë* (1877); *A Year's Letters by Mrs. Horace Mann* (1877); *Poems and Ballads: Second Series* (1878); *A Study of Shakespeare* (1879); *Songs of the Spring Tides* (1880); *Studies in Song* (1880); *The Heptalogia; or, The Seven against Sense: a Cap with Seven Bells* (1880); *Mary Stuart: a Tragedy* (1881); *Disquiet: a Dramatic Monologue* (1881), which was a parody of one of Tennyson's poems; *Tristram of Lyonesse: with Other Poems* (1882); *A Century of Roundels* (1883); *A Midsummer Holiday, and other Poems* (1884); *Mirino Estero: a Tragedy* (1885); *A Study of Victor Hugo* (1886); *Miscellanies* (1887); *Loerine: a Tragedy* (1887); *Select Poems* (1887). In his *Miscellanies* have been included several of his characteristic contributions to the ENCYCLOPEDIA BRITANNICA. (C. E. W.)

SWINE were probably imported from Spain by Columbus into Hispaniola (Hayti) in 1493, and into Florida by De Soto about 1538. Within a century later breeding stock found its way into Nova Scotia, Newfoundland, Canada, and Virginia.

Notwithstanding the receipt from foreign countries of an occasional pair or trio of superior specimens, such as the Woburns or Bedfords sent by the duke of Bedford to Gen. Washington, there was, prior to 1815-30, but little interest manifested in any general improvement, and the stock of the country was mainly made up of coarse, ungainly brutes, considered of moderate value to roam at will in the forests, where, subsisting on mast, roots, and reptiles, they grew in from two to four years to weights of 150 to 400 pounds gross, of fairly good and sweet-tasted meat, with a minimum quantity of fat or lard. Since 1830 many improved swine of different names and characteristics have been imported from England for breeding purposes, and used with remarkable effect in giving to America a greater number of superior pork-producing animals than is possessed by any other country. The old-time stock of England was coarse and deficient in fattening

qualities; and the great means of improvement was the using of boars of the compact, fine-boned Chinese, Siamese, and Neapolitan stock, to which all the best swine now on the globe are largely indebted for their most valuable characteristics.

The swine of America consist mainly of the following breeds or their crosses: Berkshire, Poland-China, Chester, white Suffolk, Essex, Jersey reds, Cheshires, and Victorias. The breed known as Poland-China had its origin early in the present century in southwestern Ohio. John Wallace, of Union Village, while visiting Philadelphia in 1816, purchased an imported boar and three sows, designated as "big Chinas," and took them to Warren county. Their progeny became popularly known as "Warren county hogs." They were improved by mixture with Berkshires in 1826 and with "Irish Graziers" in 1838. The stock thus produced constitute the basis of the breed known as "Poland-China." There appears to have been no admixture of other blood in the breed since 1840. For a long time there was great diversity in the designation for the breed, but the National Convention of Swine-breeders, at Indianapolis, in November, 1872, compromised on Poland-China as the name by which it should be called.

Great improvement has been made, especially since 1870, in the form and finish of these swine, and while prior to that time they were white- and black-spotted, they are now bred more nearly black, and in many instances are marked very much like the Berkshire. The best specimens are well-haired, have good length, short legs, broad, straight backs, deep sides, flanked well down on the leg, broad, square hams and shoulders, deep chests, short, full, high-crested necks, heavy joints, short heads, fine muzzles, moderately fine and drooping ears, and have very quiet, gentle dispositions. For size they are equal to any swine raised, and are properly classed among the largest breeds. Much attention is being paid to keeping accurate record of their pedigrees, and for that purpose different associations of breeders have published herd-books. Among these are the *American*, at Vinton, Iowa; the *Central*, at Indianapolis, Ind.; and the *Ohio*, at Dayton, Ohio.

The Berkshire was well known as a distinct breed in Southern England a century ago, when the stock of that name were ungainly, coarse-boned—but short-legged—flat-sided, and lop eared, and required two to three years in maturing. On account of yielding a large percentage of lean meat mixed with their fat, they were favorites for making bacon.

The earliest importation of these into the United States is supposed to have been made to New Jersey in 1823; the next to the neighborhood of Albany, N. Y., in 1832. In 1839, Bagg and Wait, English farmers, settled in Orange Co., N. Y., began importing largely, selling their stock in Kentucky, Tennessee, Missouri, and the South. They were at that time animals of superior excellence, but under the neglectful system of stock-raising then prevailing they deteriorated rapidly and their popularity waned. English farmers, however, never lost faith in the value of the breed, and continued to improve it from year to year. About the year 1865 enterprising Americans were again attracted by the good qualities of the swine and began making importations of the best obtainable. Each year since has witnessed improvement in form and quality, and the stock has been distributed throughout every State and Territory, being greatly esteemed either for pork-production pure or for crossing on other sorts.

Among the qualities that commend the Berkshires to the favor of breeders and feeders are their remarkable uniformity in color, form, and quality; great muscular power, vitality, and activity; strong diges-

tive and assimilative powers; their aptitude for fattening and attaining heavy weights. Their flesh is the highest quality of pork for all purposes. Their standard of characteristics and markings, as agreed upon by American breeders in 1872, was as follows: "Color black, with white on feet, face, tip of tail, and an occasional splash of white on the arm. While a small spot of white on some other part of the body does not argue an impurity of blood, yet it is to be discouraged, to the end that uniformity of color may be attained by breeders. White upon one ear, or a bronze or copper spot on some part of the body, argues no impurity, but rather a reappearing of original colors. Markings of white other than those named above are suspicious, and a pig so marked should be rejected. Face short, fine, and well-dished, broad between the eyes. Ears generally almost erect, but sometimes inclining forward with advancing age; small, thin, soft, and showing veins. Jowl full. Neck short and thick. Shoulder short from neck to middling deep from back down. Back broad and straight, or a very little arched. Ribs long and well sprung, giving roundness of body; short ribs of good length, giving breadth and levelness of loin. Hips good length from point of hips to rump. Hams thick, round and

England. Jeffries' stock and its progeny continued to be bred on and with the original stock of the county, until its hogs attained a wide reputation for both size and quality. In Pennsylvania and neighboring States the new breed was the favorite. At the fair of the U. S. Agricultural Society at Philadelphia in 1856, at the U. S. Fair at Richmond, Va., in 1858, at the State fairs of Maryland, Virginia, and Pennsylvania, they stood almost unrivalled. After 1865 much attention was given in all parts of the Union to raising better stock than had before been common, and the reputation acquired previously by the Chester county swine caused them to be eagerly sought in greater numbers than could be supplied, but a reaction followed.

Though not adapted to all localities, the Chester whites are in many respects swine of superior value. In some portions of the West and Southwest they are considered more liable to skin diseases than black hogs. The Chester whites are among the most docile of swine, and properly classed as belonging to the large breeds; individuals of it have been fed to the enormous weight of 1300 pounds. The standard of characteristics adopted for the breed by the Swine-breeders' Convention in 1872

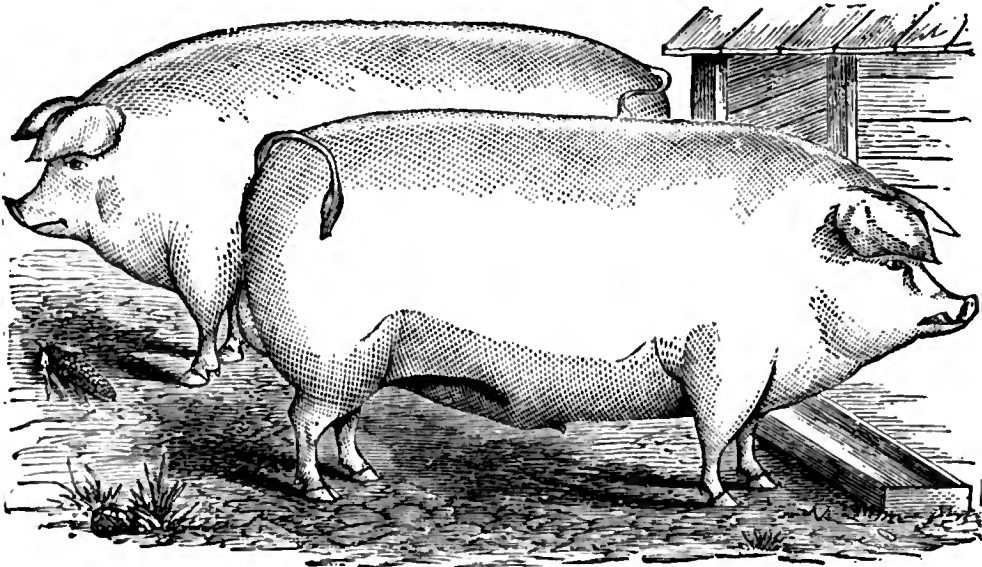

Chester White Hogs.

deep, holding their thickness well back and down to the hocks. Tail fine and small, set on high up. Legs short and fine, but straight and very strong, with hoofs erect, legs set wide apart. Size medium, length medium; extremes are to be avoided. Bone fine and compact. Offal very light. Hair fine and soft; no bristles. Skin pliable." Since the preparation of this standard great advances have been made in developing still heavier hams, deeper sides, broader, straighter backs, and shorter heads.

American breeders of Berkshires were first to adopt a systematic plan for the registration of swine pedigrees, and in 1875 organized, at Springfield, Ill., the American Berkshire Association for the purpose of the "collection, preservation, and dissemination of reliable information on the origin, breeding, and management of Berkshire swine, and the publication of a herd-book or record of Berkshire pedigrees." Several volumes have already been issued, and the record is considered of great value to breeders.

The Chester white takes its name from Chester Co., Pa., where James Jeffries, in 1818, brought a pair of superior white pigs from Bedfordshire,

was as follows: "Head short, and broad between the eyes; ears thin, and projecting forward; neck short and thick; jowl large; body lengthy and deep, and broad on the back; hams full and deep; legs short and well set under for bearing weight; hair thin, white, straight, without bristles, and if a little wavy not objectionable; tail small." Since the adoption of this standard the tendency has steadily been toward reducing somewhat the coarseness of their bones, shortening their heads, and breeding them with smaller, finer ears. The improvement has been so great that the best specimens of the breed are nearly models in form. Large, pendulous ears, coarse heads, long, coarse tails and hair, and coarse, spongy bones, are not, as in times past, characteristics of the breed, and the enormous weights to which they were formerly fed are not now considered most desirable or profitable. For farmers who desire white hogs somewhat smaller and quicker-maturing the Chester sows are excellent for crossing with smaller boars, such as the Suffolk breed affords; those who make a specialty of the latter breed claim that such a cross makes "the best Chester white possible." In Pennsylvania they

have always been held in the highest esteem. In form, size, and general characteristics, except color, they are very similar to the Poland-Chinas, but for some cause have not retained their popularity of former years among the pork-raisers of the corn-growing States, where the dark-haired hogs now largely predominate. Very little attention seems to have been paid to keeping records of the breeding of different families or strains of Chester whites.

The Suffolk is a small white breed, originated in England, where pigs essentially the same are also called Yorkshires, or small Yorkshires. English authority says they have been continually intermixed with mutual advantage, and pigs of exactly the same form, the result of crosses, are exhibited under the name of Yorkshires or Cumberlands; also, that the improved Suffolk, the Middlesex, the Colleshill, and the Prince Alberts (or Windsors) of England were all founded on the Yorkshire-Cumberland stock. Though known to some extent in all the States since 1855, they have never attained any general popularity as farmers' hogs, largely due to the fact that they were too small, not wholly satisfactory as breeders and nurses, had skins too delicate to withstand the exposure they encountered, and too nearly resembled some of their remote ancestors, described as being "perfect bladders filled with hog's lard, and nearly of the same size and quality."

The standard characteristics of the Suffolks are: "Head small, very short; cheeks prominent and full; face dished; snout small and very short; jaw fine; ears short, small, thin, upright, soft, and silky; neck very short and thick, the head appearing almost as if set on front of shoulders; no arching of crest; chest wide and deep—elbows standing out; brisket wide, but not deep; shoulders thick, rather upright, rounding outward from top to elbow; crops wide and full. Sides and flanks—long ribs well arched out from back, good length between. Shoulders and hams—flank well filled out, and coming well down at ham; back broad, level, and straight from crest to tail; no falling off or down at tail; hams wide and full all the way down; legs small and very short, standing wide apart—in sows just keeping belly from the ground; bone fine; feet small, hoofs rather spreading; tail small, long and tapering; skin thin, of a pinkish shade, free from color; hair fine and silky, not too thick; color of hair pale yellowish white, perfectly free from any spots or other color; size small to medium."

The Essex is a long-established breed of English origin, but, though of admitted good qualities, it has never become widely disseminated or popular in the United States. It was improved by the introduction of some Neapolitan hogs into England by Lord Western. The reputation of the Essex breed was established in England in 1840.

They are classed with the small breeds, but are about the largest of that class, and frequently grow to weights that would entitle them to consideration among the larger breeds, often weighing 400 to 600 pounds at maturity, though usually most profitably slaughtered young for fresh pork, breakfast bacon, or family use, for which they are highly esteemed, their meat being well-flavored and fine-grained, and their lard firm and white. When properly dressed they are but little darker than other hogs, even those with white hair. The standard agreed upon for them by the National Convention is as follows: "Color black; face short and dishing; ears small, soft, and stand erect while young, but coming down somewhat with advanced age; carcass long, broad, straight, and deep; hams heavy and well let down; bone fine; carcass, when fat, composed mostly of lard; hair ordinarily rather thin;

fattening qualities very superior. As breeders, prolific and fair nurses."

The swine variously known by the names of "Jersey reds," "red Berksaires," "Durocs," or "Saratoga reds," are quite common throughout the United States. They are of a reddish, sandy, or bronze color, and of widely varying characteristics. For over sixty years sandy-colored hogs have been numerous in southern New Jersey, especially in Salem and Burlington counties, and highly esteemed; there is a tradition that they are descendants of early importations from England of the unimproved Berksaires. The National Swine-breeders' Convention in 1872 agreed that their positive origin was unknown, but reported the following as characteristics of good "Jersey reds:" "They should be red in color, with a snout of moderate length, large lop ears, and small head in proportion to size and length of body; should be long in the body, standing high and rangy on thin legs; bone coarse; heavy tail and brush; hair coarse, including the bristles on the back."

Swine called Cheshires were mentioned by English writers subsequent to 1840-45 as "long-legged, long-eared, unprofitable giants, all but extinct." Between 1860 and 1870, in Jefferson Co., N. Y., the favorite swine were of a large white sort known as the Jefferson county or Cheshire breed, or sometimes "improved Cheshire." During those years they were exhibited at the fairs of the New York State Agricultural Society, and latterly received nearly all the prizes awarded on large breeds. The accepted description of them is that they are pure white, with very thin skin of pink color, and little hair, though not wholly uniform in the latter respect, as pigs in the same litter differ widely in the quantity of hair; the snout is often long, but very slender and fine; the jaws are plump, and the ears erect, fine, and thin; shoulders wide and hams full; their flesh is fine-grained, and they yield an extra quantity of mess pork in proportion to offal.

An American breed known as Victorias had its origin in Saratoga Co., N. Y., about 1855. They were a combination of the "Grazier," "Byfield," "Yorkshire or Suffolk," and another hog, white, long in body and well-haired, and the best of them are descendants of a sow named (about 1860 or 1862) Victoria. They have a good coat of fine, soft, white hair, and fine heads closely set on their shoulders; snout short and face slightly dished; ears erect, small, and thin; shoulders round and full; legs short and fine; back broad, straight, and level, and the body long; hams round and swelling, and high at base of tail, with plaits or folds between the thighs; tail fine; rosettes common on the back; skin thin, soft, and elastic; the flesh fine-grained and firm, with thick side pork. They can be made fit for slaughter at almost any age.

The pig being omnivorous, its highest and most rapid development calls for a generous variety of feed. During the period of growth there should be a smaller percentage of carbonate or fat-formers supplied, and the percentage of phosphates and nitrogenous compounds increased. Indian corn is rich in fat; oats, on the other hand, are especially rich in bone- and muscle-formers. Clover and grass so combine the two that when young hogs are grazed on these they make a good growth of bone and muscle, and a development of stomach which enables them to assimilate a greater amount of corn at fattening-time.

As a scale of 100 points for judging swine the National Convention of Breeders agreed upon the following: Back, 10; long ribs, 8; short ribs, 7; shoulder, 8; ham, 12; length of body, 6; flank, 6; twist, 6; snout, 4; jaw, 3; face, 3; ear, 2; neck, 4; belly, 4; skin, 5; hair, 3; bone, 3; legs, 3; feet, 2; tail, 1. (F. B. C.)

SYBEL, HEINRICH VON, German historian, was born at Düsseldorf, Dec. 2, 1817. He was a pupil of Ranke, at Berlin, though he was chiefly educated at the University of Bonn, where he became professor extraordinary in 1844. In 1841 he had published a *History of the First Crusade*, exposing some popular errors in regard to that movement. After publishing his essay on the *Origin of the German Kingdoms* he was called, in 1845, to Marburg as professor of history. In 1847 he began his political career as representative of the university in the Hessian parliament and was sent to the Congress of Erfurth. Duke Maximilian II. of Bavaria called him in 1856 to Munich, where he founded the first historical seminary in Germany, and published an historical review. In 1861 Von Sybel returned to Bonn as professor and was soon sent as deputy to the Prussian chamber. In 1867 he was elected to the constituent diet of the North German Confederation, and took an active part in Bismarck's struggle with the Ultramontane party. In 1874 he was elected to the Reichstag, and in the next year was made director of the State archives at Berlin. His edition of these important historical documents, commenced in 1878, is expected to comprise 70 volumes. Von Sybel's great work is *Geschichte der Revolutionszeit von 1789 bis 1795* (5 vols., 1853-67), which has passed through several editions and has been translated into English. It was based upon a faithful study of the archives in Berlin, Vienna, London, and The Hague. Von Sybel has also published *Die Erhebung Europas gegen Napoleon* (1860), and numerous historical essays.

SYLVESTER, JAMES JOSEPH, English mathematician, was born in London, Sept. 3, 1814. His early education was at private schools in that city and at the Royal Institution, Liverpool. His later training was at St. John's College, Cambridge; but, being a Jew, he could not receive a degree, though in 1837 he was second wrangler, and in 1839 was elected a Fellow of the Royal Society. In 1872, however, the degrees then denied him were finally bestowed; he is also M. A. of Dublin and Oxford, LL. D. of Dublin and Edinburgh, and D. C. L. of Oxford. He studied law at the Inner Temple and was called to the bar in 1850. He was made professor of natural philosophy at University College, London, and in 1852 was called to the chair of mathematics in the University of Virginia. Returning to England in 1862, he became professor in the Royal Military Academy at Woolwich, which post he held for five years. On the organization of the Johns Hopkins University at Baltimore, in 1877, Sylvester was made professor of mathematics there, but at the end of 1883 he was elected Savilian professor of geometry at Oxford, which chair he has since held. Although he has published no separate work of importance, his contributions to mathematical periodicals have been of the highest merit. His papers number altogether 250, and relate to every department of mathematics, but especially to higher algebra, which he greatly enlarged by his theory of reciprocants. He is also the inventor of the plagiograph and other geometrical instruments. Some sonnets and other poems from his pen attest the versatility of his genius. He was the first editor of the *American Journal of Mathematics* (founded in 1878), and second president of the London Mathematical Society.

SYNAGOGUE. The word *kneseth*, the proper Hebrew word for synagogue, is probably post-biblical, and certainly does not occur in the Old Testament. The word used in Ps. lxxiv. 8 is not *kneseth*, but *moedh*, the word commonly employed to denote the great festivals: The Passover, the Pentecost, the Feast of Tabernacles. The Septuagint

and Vulgate translations give the word its usual meaning in this passage (*ras éopras*; *omnes dies festos Dei*); and the meaning is entirely consistent with the context. The burning of the sanctuary was virtually the burning of all the aolemnities that had centred there. But even if the word *moedh* be here taken in the unusual meaning of "appointed places," or "places of assembly," there is nothing to establish an identity between these and the fully developed synagogue, or to justify the assertion that "such synagogues existed in all parts of Judæa in the time of Ps. lxxiv. 8, or to prove that this psalm was written after synagogues became a recognized institution.

The Great Synagogue.—The statement that Jewish tradition assigns to the so-called Great Synagogue "supreme religious authority from the cessation of prophecy to the time of the high priest Simeon the Just" needs modification. The traditions (see Maimonides in Ugolino, vol. i., col. 12; also *Hieros. in Megil.*, fol. 70, col. 4, cited in Lightfoot, Pitman's ed., x. 525, and elsewhere) include among the men of the Great Synagogue Daniel and his three companions, with Haggai, Zechariah, Ezra, Nehemiah, and Malachi, and speak of other prophets, in considerable numbers, as also included. It is necessary to distinguish between what the traditions say of the Great Synagogue as an organization and what they say of the men of the Great Synagogue as persons. Much of what is said in regard to the organization is apocryphal enough, especially with the interpretation put upon it by some modern writers; but no men whose names appear in history are more real than those just mentioned and their associates. Whatever Kuenen or others may have shown as to the organization sometimes described as the Great Synagogue, or as to the original meaning of the name, neither he nor anyone else doubts that most of those who are called the men of the Great Synagogue were veritable men, who actually did literary work in connection with the Old Testament; and it is certain that the traditions concerning this work, however distorted or exaggerated some of them may be, have a basis of truth, and that parts of the truth can be disentangled from the fiction. In particular, the most important Old Testament questions connected with the men of the Great Synagogue are questions that have nothing to do with the organization, but only with the men.

This succession of men maintained itself for several generations after the succession of the prophets had ceased, and in this sense the men of the Great Synagogue are later than the prophets; but it should not be forgotten that they were also for several generations contemporary with the later prophets, and included these prophets among their number.

The statement that only modern writers since Elias Levita attribute to the men of the Great Synagogue the completing of the Old Testament canon is perhaps true, if applied strictly to the alleged organization of that name; but it breaks down if applied to the men of the Great Synagogue as distinguished from the organization. The traditions attribute to Ezra, Nehemiah, and other men of the Great Synagogue a vast amount of work on the Old Testament books, including the "writing" (that is, in many cases, the editing) of all the latest of them. In the sense, therefore, that the canon was actually complete the moment the latest writings included in it were finished, the traditions attribute to the men of the Great Synagogue the completing of the canon; it may perhaps be true that these traditions, when rigidly sifted, recognize no other "fixing" of the canon than this, but this is the determination of it that is all-important. See, e.g., *Baba Batra* (Ven. ed. of 1520), fol. 14a. (W. J. B.)

T.

TABERNACLE: *The Central Sanctuary of Israel, and its Religious Feasts.* The author

See Vol. XXIII
p. 5 (p. 9 Am.
Rep.).

of the article **TABERNACLE**, in the **ENCYCLOPEDIA BRITANNICA**, says in regard to the detailed accounts of the Israelitish Tabernacle and its worship, as these are given in the Priest-code, that "the whole description is ideal," that it "throws back into the time of Moses the whole scheme of worship and ritual of which the second temple was the centre." This position is an essential part of the view of the Old Testament held by the succession of writers on Biblical subjects in the **ENCYCLOPEDIA BRITANNICA**; if it be admitted that the tabernacle and its services, as described in the Pentateuch, are matters of historical fact, then their whole scheme falls to the ground.

The Biblical accounts testify that the tabernacle was constructed in the vicinity of Mount Sinai. This gives the author of the article on **SINAI**, in the **BRITANNICA**, an opportunity to open and close his treatment by an attack on "the historicity of the Hebrew records involved." He says: "The absence of exact topographical detail on the part of the Biblical narrators, who always speak of Sinai as if it were a single summit, and give no hint about several summits of which it is one, shows that in their time there was no real tradition on the matter, and that all attempts at identification are necessarily vain." But this writer cannot be unfamiliar with the fact that the usual Hebrew word for mountain denotes a given mountainous region as properly as a single summit. Which of the two it denotes in any particular passage, can only be known from the context, or from known facts concerning the topography. He has no right, therefore, to say that these narrators always speak of Sinai as if it were a single summit; neither he nor anyone else knows that to be a fact; the presumption is that they speak interchangeably, sometimes of the region and sometimes of a particular peak, and there is no evidence to overthrow this presumption. The fact that their lack of definition in this particular, and their lack of details, render it difficult to settle some points as to the topography, is not at all discrediting to the historicity of the writings. It is a matter of fact that in the Sinaitic peninsula, as well as in Egypt and in Palestine, a growing knowledge of the topography, while it often overthrows our theories as to the meaning of the Biblical statements, yet shows the correctness of the statements themselves. Even a man who holds that the Pentateuchal accounts of the tabernacle were written after the exile, ought to be able to see that they were written by some one who was familiar with the Sinaitic peninsula.

The Pentateuchal accounts inform us that Israel had a public sanctuary-tent, earlier than the one that Moses made at Sinai, Ex. xxxiii. 7-11. See also, in this work, **ISRAEL, Period I, Institutions**. It is not a fair reading of the history to regard this as an older and contradictory mention of the tabernacle that Moses is said to have made at Sinai. On the contrary, it is spoken of as a part of a group of pre-Sinaitic institutions, that were either superseded by the legislation at Sinai, or incorporated into it.

The Priest-code writings circumstantially describe the tabernacle itself and its furniture, its system of offerings and sacrifices, its priesthood, its sacred year of daily burnt offerings, sabbaths, and appointed festivals, and in virtue of all these, its character as the one legal sanctuary of Israel. In regard to each of these points, the books of the Old Testa-

ment, with more or less continuity, give the subsequent history of the institutions founded by Moses, and in regard to each of them, the several writers in the **ENCYCLOPEDIA BRITANNICA** deny the historicity of the account thus given.

The tabernacle itself and its furniture. Besides what we might infer from what is said concerning the sacrifices, the priests, the festivals, etc., we have the following direct statements: The tabernacle (*mishkan*) was recognized as in existence, in western Israel, after the conquest by Joshua, Josh. xxii. 19, 29. The tent of meeting had been set up at Shiloh by the congregation of Israel, Josh. xviii. 1. The inheritances of the tribes were distributed before Jehovah, at the doorway of the tent of meeting in Shiloh, Josh. xix. 51. In Eli's time, the tent of meeting was still in Shiloh, perhaps within the temple inclosure there, 1 Sam. ii. 22. When David brought up the ark to Jerusalem, he pitched a tent for it, 2 Sam. vi. 17; 1 Chron. xvi. 1, while the Chronicler adds that the *mishkan* of Jehovah was then at Gibeon, close by, and the force of Levitical ministers was divided between the two points. xvi. 39. This statement is repeated in 1 Chron. xxi. 28 sq., 2 Chron. i. 3, and on the face of it seems to be confirmed by what is said as to Solomon's sacrificing in Gibeon, and his vision there, 1 Ki. iii. 4-5; ix. 2. During all this period, Jehovah represents himself as dwelling in tent and *mishkan*, 2 Sam. vii. 6. The *mishkan* of Jehovah's glory is recognized in Ps. xxvi. 8. The tent of Jehovah, with its altar (the tent at Gibeon, rather than the one at Jerusalem), figures prominently in connection with the accession of Solomon, 1 Ki. ii. 28, 29, 30; i. 39. And finally, we are told that, at the dedication of Solomon's temple, the priests and Levites brought up not only the ark, but "the tent of meeting and all the holy utensils that were in the tent," 1 Ki. viii. 4; 2 Chron. v. 5. In Eli's time we are told that the ark was in the temple at Shiloh, 1 Sam. iii. 3, presumptively in its proper sanctuary in the tabernacle, which we have seen was also there; and that it was removed from Shiloh at the time when it fell into the hands of the Philistines, iv. 3, 4. Thus separated from the tabernacle, we have a pretty full account of its various fortunes, till the two were placed in Solomon's temple. The shew bread of Ex. xxv. 30; xxxv. 13, appears in 1 Sam. xxi. 6, and again among the arrangements of Solomon's temple, and those in preparation for the temple, 1 Ki. vii. 48; 2 Chron. iv. 19; 1 Chron. xxiii. 29, etc. In 2 Chron. i. 5, cf., 1 Chron. xxi. 29, it is said that the brazen altar made by Bezaleel was still in use in Solomon's time.

Certainly this line of statements, especially when corroborated by the many parallel allusions to the sacrifices, the festivals, the priesthood, and other institutions that had their centre in the tabernacle, appears, on the face of it, to be entirely credible as history. If we are not to accept the statements, we ought to have satisfactory reasons for rejecting them. Of what sort are the reasons for this, as they are actually adduced?

The author of the article on the Tabernacle, in the **BRITANNICA**, says: "The Chronicler indeed, who had before him the Pentateuch in its present shape, assumes that after the Israelites entered Canaan the tabernacle continued to be the one legitimate place of sacrifice, until it was superseded by Solomon's temple, and represents it as standing at Gibeon in the days of David and his son (1 Chron. xxi. 29; sq. 2 Chron. i. 3). But the book of Kings knows Gibe-

on only as 'the greatest high place' (1 Ki. iii. 4). But we have seen that the continued existence of the tabernacle is not a mere assumption of the author of Chronicles, but a matter of fact attested by the books of Joshua, Samuel, and Kings. The fact that the book of Kings knows of Gibeon as the seat of the great high place (this book recognizes no other high place as legitimate) is perfectly consistent with the view taken in Chronicles, that the great high place was constituted as such by the fact of the presence of the tabernacle there. The account in Kings does not contradict that in Chronicles, but confirms it.

On this point, the author of the same article says: "Two passages in the . . . books of Judges, Samuel, and Kings speak of the tabernacle . . . ; but external and internal evidence show them to be interpolated (1 Sam. ii. 22; 1 Ki. viii. 4)." But the mention of the tabernacle in 1 Ki. viii. 4 is in the Septuagint, as well as in the Hebrew copies, and that in 1 Sam. ii. 22 is in the Hebrew and the Alexandrian Septuagint, though not in the Vatican copy of the Greek. In each case the mention of the tabernacle fits the context, and fits all the Biblical statements that touch the matter. A man who regards the Priest-code writings as unhistorical must needs find in that circumstance a reason for regarding these passages, which ascribe historicity to the Priest-code writings, as interpolations; but really there is no other reason for so regarding them.

The author of the same article farther insists upon what he regards as the fact that at Shiloh the ark "was housed not in a tent but in a temple (1 Sam. iii. 3, 15)." But, admitting that there was a permanent temple structure at Shiloh, the account testifies that the tabernacle was also there, and there is no difficulty in understanding that the tabernacle may have stood somewhere within the temple precincts, with the ark in its holy of holies, and the legal arrangements for sacrifices connected with it.

The offerings and sacrifices connected with the tabernacle. The Pentateuchal writings testify that Israel had institutions of this sort from the time when Abraham first came to Palestine; that there were Israelitish institutions of sacrifices in Egypt, just before the exodus, and in the wilderness, in the interval between the exodus and the giving of the Sinaitic legislation, Gen. xii. 7; xiii. 2 sq. et al.; Ex. x. 25; xii. 3-24; xviii. 12; xxiv. 5, etc. They affirm that, under Moses, these earlier institutions were regulated by various statutes, and supplemented. The collection of them found in the Pentateuch is in no proper sense a code, but is simply a succession of papers placed one after another, with no apparent system. The ritual described differs materially from that of either Solomon's temple, or the second temple; it provides for no courses in the ordering of the priests and Levites, no corps of gate-keepers and other attendants of that class, no singers, no wood-offering (*cf.* Neh. x. 35 [34]; xiii. 31), no money provision for current expenses (*cf.* Neh. x. 33-34 [32-33]), the half shekel tax of Ex. xxx. 12-16; xxxviii. 25-28, being a very different thing from the permanent tax of Nehemiah. On the other hand, traces of the existence of many of the sacrificial usages described in this legislation are found throughout the history, from Joshua to Nehemiah. The great day of atonement, indeed, is not mentioned in the Old Testament outside the Pentateuch. The word for sin-offering, except perhaps in Ps. xl. 7 [6], occurs only in Ezekiel, the Pentateuch, and the post-exilic books, and is first applied in Chronicles to the times of Hezekiah. The current phrases to describe atonement for sin occur in Deuteronomy, in 1 Sam. iii. 14, in 2 Sam. xvi. 3, and in Ps. li. 9 [7] and other Psalms, but they are abundant only in the Priest-code and the later Old Testament books.

But most of the other distinctive terms for sacrifice are found sprinkled through the books of Judges, Samuel, Kings, and the earlier prophets.

The passages in which these terms occur are very numerous. It is impossible here to refer to them in detail. A thorough examination of them would not lead to the conclusion that the Pentateuchal system of sacrifices and offerings was in complete operation in Israel throughout the period from Moses to Nehemiah; but equally, it would not justify the conclusion that the essential points of the system were ever unknown in Israel during that period. Such passages as Deut. xii. 8 and Josh. v. 2-8, show that the system, so far as the whole people was concerned, was in very imperfect operation even in the time of Moses himself. The ritual of the times of Eli has its points of difference from that of the Pentateuch, as well as its points of resemblance. But in the successive revivals of ritual, under David and Solomon, under Hezekiah, under Josiah, under Ezra, the claim made in the records is that the revival followed the Mosaic precepts that were in the possession of the priests; and there is nothing in the phenomena of the times to contradict this claim.

In the article *TITHES*, in the *ENCYCLOPEDIA BRITANNICA*, the view is presented that the older Israelitish legislation had nothing to say of tithes, but demanded as due to Jehovah the firstlings of the flock and herd, and also, without fixing the amount, the first-fruits of agricultural products; that before the writing of the Deuteronomic legislation in the seventh century B. C., the amount of the first-fruits had come to be fixed at a tenth; that in that code, Deut. xii. 6, 11; xiv. 22 sq., an innovation is introduced to the effect that the tithes "must be consumed at a central, instead of a local, sanctuary;" and that in the times of Ezra and Nehemiah there was put in force "the new law of the priestly code (Num. xviii. 21 sq.), in which it is formally laid down that the tithe is a tribute paid to the Levites, who in turn pay a tithe of it to the priests." It is sufficient disproof of this that the Priest-code, Deuteronomy, and Nehemiah alike regard the tithes as something entirely distinct from the first-fruits, Num. xviii. 12, 13, 21-26; Deut. xxvi. 10, 12; Neh. x. 35-38; xii. 44. This theory of the evolution of the tithing system has no elements of continuity or of probability that would justify a truly critical scholar in accepting it in preference to the specific testimony of the different accounts, which ascribe the laws concerning tithes to Moses.

In the article on *SACRIFICE* in the *ENCYCLOPEDIA BRITANNICA* is a similar theory of the evolution of sacrificial worship. It holds that a sacrifice "is primarily a meal offered to the deity." Either the deity alone partook, as in the case of the burnt offering, or he shared the sacrificial feast with his worshippers. Animals came to be preferred as sacrifices, because animal food was thought of as more luxurious than vegetable food. In certain stages of savagery, it is unlawful for a tribesman to eat the totem animal of his own tribe, and praiseworthy for him to eat that of a hostile tribe, and thus certain animals come to be regarded as fit for food or sacrifice, while certain others are unfit. "Generally speaking, then, the original principle on which a sacrificial meal is chosen is that men may not eat what cannot be offered to their god." As the flesh of their enemies is particularly choice food, in the view of certain savage tribes, the practice of offering human sacrifices began, being, in many cases at least, the product of cannibalism. But somehow or other, a different idea came to be connected with human sacrifices—that of the slaying of the victim to placate the deity, who was offended, and whose vengeance must be satisfied; the sacrifice became picaular. In due time there came to be picaular ani-

mal sacrifices also. In some cases, the offering of an animal was of the nature of a fine; "more usually, however, the life of an animal is accepted by the god in place of a human life."

This theory is supposed to find some support in the Old Testament. It is asserted that "the slaughter of an animal . . . seems to have been always sacrificial in early Greece," and then, that "among the Semites sacrifice and slaughter for food are still more clearly identified; the Hebrews use the same word for both." This last statement has only a meagre support from the Hebrew lexicons, and really none at all from the usage of the Old Testament; there is no instance where a word of the stem Z-B-H occurs where it may not naturally be understood to denote a sacrificial feast, either as a fact, or, in a very few instances, figuratively, while the words of the stem T-B-H are not currently used to denote sacrifice. Again, the alleged connection between totemism and the distinction of clean and unclean animals cannot be traced in the Pentateuchal scheme; the animals allowed for food are different from those allowed for sacrifice, the food animals including many species that are named, and an immense number of others that fall under general designations; while those for sacrifice are three species of animals and two of birds. Further, the theory just described requires us to regard "the presentation of the gift" as "the central feature in every ordinary act of worship." If the laying of the hand on the head of the victim, in the Hebrew ritual, was a mere act of presentation, then this fact fits the theory; but if it was rather an emblematic confession of ill desert, and a prayer for pardon (Lev. xvi. 21; v. 5; Num. v. 7), it does not at all fit the theory.

On the basis of this theory it is sometimes argued, that, in such cases as that of Jephthah, we have a picture of the religion of Jehovah in the stage when it still recognized the propriety of human sacrifices; that the story of Abraham and Isaac indicates a later stage, in which this religion outgrew the idea of human sacrifice; that its sacrificial system gradually developed until, in post-exilic times, the full pentateuchal ritual had come to be in existence. In regard to all ideas of this kind, it is sufficient to say that they contradict the only known ancient records that bear testimony in the case, and that they have no such intrinsic credibility as to justify our accepting them in preference to the records.

Concerning the *priesthood of the tabernacle*, and the questions depending on it, see PRESSER, in this work.

The *sacred Year of the Tabernacle*. In Numbers xxviii., xxix., and elsewhere in the Pentateuch, we find precepts for a class of acts of worship at certain fixed times throughout the year—the morning and evening daily offerings, the special offerings and services for the Sabbaths, the new moons, the Passover, the Pentecost, the Feast of Tabernacles, with its preliminary ceremonies of the blowing of trumpets and the day of Atonement. Both the Pentateuch and the other historical books that mention these attribute the institution of them to Moses, with the modification that some of the elements involved were incorporated into the Mosaic legislation from older sources.

In opposition to the statements of the records, the author of the article on the SABBATH in the ENCYCLOPEDIA BRITANNICA cites the words of Jesus in the New Testament to prove that the Sabbath of the Tanaite scribes (which he assumes to be the same with that of the Priest-code) was different from that which prevailed in Israel before the exile. He makes a grave mistake when he assumes that the Pentateuchal Sabbath is that of the scribes, and is to be interpreted by their spirit, instead of by the spirit of Old Testament prophecy and history. Not

much is said concerning the Sabbath in the pre-exilic books outside the Pentateuch. But in the few places where it is mentioned, we learn that the Sabbath was a day of abstinence from labor, Amos viii. 5; a day of special religious services in the temple, 2 Ki. xi. 5, 7, 9, cf. 2 Chron. xxiii.; the day of changing the shew bread, 1 Chron. ix. 32, cf. Mat. xii. 2 sq.; a day regarded as especially suitable for consulting a prophet, 2 Ki. iv. 23; a day associated in thought with the new moons and festivals, and their assemblies, Isa. i. 13; Hos. ii. 13 [11]; 1 Chron. xxiii. 31; 2 Chron. ii. 3 [4]; viii. 13; in fine, as a day which, in many ways, was regarded as set apart to Jehovah, and no longer belonging to a man himself. In fine, counting one or two severe laws of the Priest-code as police regulations, designed for Israel in camp rather than for permanent enforcement, the Sabbath of the Priest-code is, so far as appears from the particulars given, the same with the Sabbath of the other Pentateuchal codes, and the same with the Sabbath that appears in the history; and each differs, in principle, from the Sabbath of the scribes, in precisely the points in which that Sabbath-doctrine contradicts the teachings of Jesus.

The mention of the great sacred feasts that are said to have centred in the tabernacle, in the accounts of the pre-exilic times, is as full as could be expected. Aside from the passages that specify particular feasts, we have an allusion to Jehovah's yearly feast in Shiloh, Jud. xxi. 19; Elkanah and his contemporaries made annual pilgrimages to Shiloh, 1 Sam. i. and ii.; the appointed time of 1 Sam. xiii. 8, 11, may have been one of the festivals; the Chronicler represents that one principal object of David and Solomon in building the temple was to make provision for the feasts, 1 Chron. xxiii. 31; 2 Chron. ii. 4; the feasts are well known at the time of Solomon's death, 1 Ki. xii. 32, 33; they are prominent in the writings of Amos, Hosea, Isaiah, and Nahum, and in the Psalms, Amos v. 21; viii. 10; Hos. ii. 13 [11]; ix. 5; Isa. i. 14; xxix. 1; xxx. 29; xxxiii. 20; Nah. ii. 1 [i. 15]. Solomon is said to have observed the three feasts mentioned in the Pentateuch, 1 Ki. ix. 25; 2 Chron. viii. 13, both passages mentioning the "three times in the year," though the names are given in Chronicles only.

Besides the instances in which it is alluded to in connection with the other festivals, the Feast of Tabernacles is several times mentioned by itself. In Josh. viii. 35, the phraseology used is that of the law for the Feast of Tabernacles, Deut. xxxi. 10-12, and the suggestion is that the solemnities recorded in the previous verses took place at the time of the feast. In 2 Sam. xi. 11, Uriah says that the ark and Israel and Judah, but not the army, are dwelling in booths; on the face of it this looks like a celebration of the feast of booths. The feast of Jud. xxi. 19 had a vintage dance connected with it, and may well have been the Feast of Tabernacles, though if it was, the dance was a mere incident of it. Samuel was born "at the revolutions of the days," 1 Sam. i. 20, and the account connects an annual feast with his birth; the word translated "revolution" is used only here and 2 Chron. xxiv. 23; Ps. xix. 7 [6]; and Ex. xxxiv. 22, where "the revolution of the year" is the time for the feast of ingathering. The dedication of Solomon's temple was at the time of the Feast of Tabernacles, 1 Ki. viii. 2, 65-66; 2 Chron. v. 3; vii. 8, 9. This feast is very prominently mentioned in Zech. xiv. 16, 18, 19.

The writer on the TABERNACLE in the ENCYCLOPEDIA BRITANNICA, however, holds that this feast, though in existence from early times, did not become what is called the Feast of Tabernacles—that is, more properly, the feast of booths, as described in the priestly legislation—till the times of Nehemiah. He

says that from the passage beginning Neh. viii. 14, "we learn that the use of booths on that occasion had no foundation in traditional usage, but was based directly on the law, which then for the first time became generally known." But the passage does not say that the law then first became generally known. It does not intimate that the use of booths was an innovation on traditional usage. In a sentence constructed to throw especial emphasis on the adverb, the author of Nehemiah says that the children of Israel had not so done the thing since the times of Joshua; the fair inference is not that they had never done the thing before, but rather that they had always been in the habit of doing it, but never so conspicuously as on this occasion.

The writer of the article mentioned above further says: "According to the law in question, the booths were to be a memorial of the wilderness wandering, Lev. xxiii. 43, but of this there is no hint in Deuteronomy; and . . . it is certain from Exodus that the feast had originally agricultural and not historical significance." But the two are not necessarily exclusive; it is entirely credible that the agricultural significance may have had a historical meaning added to it, as the accounts say was the case. There is no need, therefore, to look for any custom of living in booths during the vintage, or of providing temporary shelter for those who came from a distance to the festivals, in order to account for the booths of this feast; the historical reason assigned for them is sufficient, though it does not exclude the other reasons, provided they are authentic.

The same author says: "In Jud. ix. 27 we find a vintage feast at Shechem among the Canaanites, from whom the Israelites first learned the ways of agricultural life, and from whom so much of the popular religion was copied." Here the intimation that the Feast of Tabernacles is a development from some Canaanite vintage feast is as gratuitous as the statement that the Israelites first learned agriculture from the Canaanites, or that much of the popular religion—meaning the religion of Jehovah, then counted correct—was copied from them. He further explains that the autumnal feasts of Israel, that finally developed into the Feast of Tabernacles, were originally held at many local sanctuaries, and that "it was the fame of great shrines that gradually tended to draw worshippers from a distance to temples like those of Jerusalem and Bethel. Finally, the Deuteronomic law of the one sanctuary . . . put an end to all local religious feasts," and "obscured the old significance of the festival cycle, and made room for the historical interpretation of the celebrations." This might be plausible if there were some proof that the feast in question was ever celebrated elsewhere than at the central sanctuary, but of such proof there is no vestige.

According to the Biblical accounts, as they now stand, the Passover festival was instituted by Moses, just before the Israelites left Egypt, and was at that time kept by them, though in a primitive and incomplete form. Whether it superseded or incorporated any older festival usages, we are not informed, but certainly no one can trace any connection between the passover and the sacrifice to Jehovah which Israel asked Pharaoh's leave to make in the wilderness. If the writer of Ex. xii. 34, 39, was writing history, he certainly did not intend to be understood as here giving a different account of the origin of the feast of unleavened bread from that which he had already given in verses 3-28; verses 34 and 39 are rather to be understood as mentioning an incident that occurred, illustrating the haste with which the people left Egypt, and also illustrating how certain people, who had been negligent about obeying the command to put away leaven from their houses, were, after all, providentially compelled to eat unleavened bread.

The festival having been thus instituted, supplemental directions were afterward given, at different times, in regard to it, defining its position in the sacred year, its relations to the harvest, and its relations to the central sanctuary, and defining other points concerning it.

In contradiction to this, the articles on PASSOVER and PENTATEUCH in the *ENCYCLOPEDIA BRITANNICA* represent that this festival was, in its beginnings, a spring feast, arising from "the accumulation of the sacrifices of firstlings and fattings" at that season; that "it appears from the Jehovist that something of this kind existed before the exodus, and gave occasion to the request of Moses for leave to lead the people out into the wilderness to sacrifice to Jehovah;" that the feast of unleavened bread was originally a different thing—an agricultural feast, presupposing a fixed residence in Canaan (as if they had no agriculture in Egypt); that up to the time of Josiah "this sacrifice was not tied to any set feast;" that the name *pesach* originally was probably that of some dance attendant on the feast, the historical idea now connected with it being a later interpretation; that the sacrifice of the lamb and the feast of unleavened bread became united into one in Josiah's time; that the feast underwent further modifications during the exile, and again after the exile. In proof that "the Deuteronomic passover was a new thing in the days of Josiah," is urged the passage beginning 2 Ki. xxiii. 21: "There was not made the like of this passover from the days of the judges who judged Israel, and all the days of the kings of Israel and the kings of Judah." But the difference between this particular passover and previous feasts of the kind, as we naturally understand by the context, did not consist in the fact that the feast itself, in the form in which it was now observed, was an innovation, but rather in the circumstances and the spirit of the observance.

Evidently, the view thus sketched is inconsistent with the Pentateuchal accounts. It is equally at variance with the statements of the other historical books. These inform us that the passover was celebrated shortly after Joshua crossed the Jordan, Josh. v. 10, 11; that it was one of the festivals of Solomon's time, 2 Chron. viii. 13; cf. 1 Ki. ix. 25; that it was prominent in Hezekiah's reform, 2 Chron. xxx. 1, 2, 5, 15, 17, 18, 13, 21. Confessedly, the books of Joshua and Chronicles know of no separation between the passover and the feast of unleavened bread, but use the terms together in their descriptions. Confessedly, the writers of 2 Ki. xxiii. and 2 Chron. xxxv. represent Josiah's passover to be of the genuine Mosaic type, not a new feast just contrived.

Under the outline found in the Pentateuch, every Biblical statement concerning the passover can be naturally placed, with no necessity for rejecting any of the testimony, or putting a forced meaning upon it. The account thus obtained will be found to be simple, intelligible, and consistent, and suited to the explanation of all incidental questions that arise on the subject. In contrast with this, the account found in the *BRITANNICA* article, based upon a proposed reconstruction of the Hexateuch, is complicated, involves improbable assumptions, and requires us to reject as false or impossible both a large proportion of the statements made in the Hexateuch itself, and many of the statements of the other books.

The Tabernacle as the Central Sanctuary. The three Pentateuchal laws concerning places of sacrifice are found in Ex. xx., in Lev. xvii., and in Dent. xii., supplemented by other passages in Deuteronomy. The first of the three, so far as its words go, neither restricts sacrifice to one place nor implies more places than one for it. This law is referred to

in Josh. viii. 31, where the altar on which Israel sacrificed was not the brazen altar of the tabernacle, but one reared for the occasion. Perhaps it is again referred to in 1 Ki. xviii. 30-32, where again the altar is not that of a central national sanctuary. On the supposition that both this law and the other two were given by Moses, this law is to be regarded as stating what was correct Israelitish usage up to the date when it was given, as regulating the usage from then to the giving of the subsequent laws, and as covering any cases that might afterward arise, which did not fall within the scope of the subsequent laws. The second in date of the three laws is that given in Lev. xvii., for, many assertions to the contrary notwithstanding, Dent. xii. distinctly pre-supposes Lev. xvii., instead of being presupposed by it; compare, for example, Dent. xii. 15 with Lev. xvii. 13, and so all through the two chapters. This second law is applicable to Israelites in camp or out of camp, but only when Israel is encamped around the tabernacle. It may have been enforced in the case of whatever guard remained steadily with the tabernacle during the thirty-eight years of the wandering, but it certainly was not enforced with the great body of the people during that time. In Dent. xii. 8, and context, the people at large are rather excused than rebuked for doing as they pleased, in contrast with sacrificing at a central altar only. After the settlement in Canaan, this law could have no application to the people in their homes, though it might apply if expeditions were made in which they took the tabernacle with them. The third sanctuary law is that given in Dent. xii. and subsequent passages.

Under this third law, Jehovah was to choose a place in the promised land, to put his name there, and the people were to come to this place from every part of the land, for certain acts of sacrifice and worship, and these they were forbidden to perform elsewhere. Obedience to this law would always be impossible, except when Israel was settled in Palestine, was at rest from enemies, and was in possession of a place which was recognized as the one chosen by Jehovah for the purpose. Accordingly, these three limits are explicitly stated in the law itself. Further, this law is qualified by an express permission to make private sacrificial feasts anywhere and at any time, provided due care was taken to prevent these from being confounded with the public rites that were limited to the central sanctuary, Dent. xii. 15, 21, with the context.

On the supposition that these three laws are all genuine precepts of Moses, we should expect to find the third law in constant operation in Israel in Palestine, unless conditions of political unrest existed that should render it infeasible, or unless a condition of things should arise in which no place was recognized as the one chosen by Jehovah to place his name there. Whenever either of these two conditions existed, obedience to the Deuteronomic law would become impossible, and usage in Israel would again become subject to the two earlier laws, as these might apply. In other words, all the laws alike recognize the place where the tabernacle and the ark are as the national centre of worship. But when the tabernacle and the ark are separated, or when either or both of them move from their permanent location, or when there is no permanent location for them, and they simply wander from place to place, these facts constitute modifications of circumstances that affect the applicability of the several laws.

As a matter of fact, the books of the Bible assert that the condition of rest was given by Jehovah to Israel in the time of Joshua, that Shiloh then became the abiding place of the ark and tabernacle, and therefore the national sanctuary, and remained so till the time of Eli or later, and that only Shiloh and Jerusalem ever held this position, Josh. xviii. 1, 8, 9, 10; xix. 51; xxi. 2; xxii. 9, 12; Jud. xviii. 31; xxi.

12, 19, 21; 1 Sam. i. 3, 9, 24; ii. 14; iii. 21; iv. 3, 4, 12; xiv. 3; 1 Ki. ii. 27; Ps. lxxviii. 60; Jer. vii. 12-14; xxvi. 6-9, with contexts. They represent, however, that the ark was sometimes moved from Shiloh, and that some respect was paid to the places that had been made sacred by the experiences of the patriarchs or of Israel in past times, 1 Sam. iv.; Jud. xx. 26-23; Josh. xxiv., especially ver. 26; 1 Sam. x. 8; xi. 14, etc. They further represent, however, that during a large part of the time from Joshua to David, and for the Northern kingdom after Solomon, the conditions of rest were not such as to render obedience to the Deuteronomic law possible; and that, for some portion of the time between Eli and David, there was no longer a recognized permanent place for the ark and tabernacle together. They represent that under David Jehovah again gave Israel rest, and chose a place to put his name there, and that, in pursuance of this, David placed the ark in Jerusalem, and the tabernacle near by, in Gibeon, thus constituting a divided central sanctuary, until the temple was ready to absorb the functions of both places, 2 Sam. vii. 1, 11; 1 Chron. xxii. 9, 18; xxiii. 25; 1 Ki. v. 4; 1 Chron. vi. 31, etc.; 1 Ki. viii. 44, 48, etc.; and the passages already referred to.

Parts of this account come from several independent witnesses. The account is perfectly continuous and consistent. Why should it not be believed?

In the article TEMPLE, in the ENCYCLOPEDIA BRITANNICA, we are reminded that there had been temples in Israel, both public and private, before that built by Solomon. The instances mentioned are the temple at Shiloh, and Micah's house of gods, Jud. xvii. 5. There might have been added the shrines at Dan and Ophrah, Jud. xviii. 30, viii. 27, and it ought to have been added that these places, with the exception of Shiloh, are mentioned with clear indications of disapproval. It is said that in the matter of the temple, "as in other matters, the Israelites must have learned from the Canaanites." But how does this follow? We are told that "in Solomon's temple both the oracle and the outer cella had folding doors," and that "the Chronicler (2 Chron. iii. 14) introduces a veil in the first temple," this being a feature of the post-exilic temple. But the folding doors do not necessarily exclude the veil. It is further said that "the first temple was primarily the royal chapel, and the kings did as they pleased in it; the second temple was the sanctuary of the priests." But several recorded instances, notably the rebellion against Athaliah, and the withstanding of Uzziah, 2 Ki. xi.; xv. 5; 2 Chron. xxiii.; xxvi. 21-23, show that the king's power in the first temple was limited; and the history throughout makes the first temple, no less than the second, the sanctuary of the priests.

Like these are all the attempts to prove that Israel had no proper central sanctuary until the times of Josiah. The historical notices of the successive kings from Solomon mention that the worship in the high-places was maintained; but they mention it with disapproval, so that each instance is an additional testimony to the fact that the law of the central sanctuary was obligatory throughout this period. Before Solomon many sacrifices and other acts of worship are mentioned as occurring at other places than the central sanctuary, and a plurality of legitimate altars to Jehovah are recognized as existing in the Northern kingdom, in the days of Elijah, 1 Ki. xviii. 30, xix. 14. But all these instances are explained, either as being illegal, or as being instances of the merely private sacrificial feasts that are provided for in the law itself, or as occurring in circumstances in which the law was inapplicable, and the usage was therefore governed by the earlier laws. In fine, there is no reason that will stand the test of true criticism for refusing to accept the Biblical account of the tabernacle and its functions as the central sanctuary of Israel, as historical and correct. (w. J. B.)

TAINÉ, HIPPOLYTE ADOLPHE, French critic and literary historian, was born at Vouziers, April 21, 1828. Before he left school he was marked as destined to achieve distinction. At the Collège Bourbon he gained the prize for rhetoric in 1847 and in the next year was at the head of those admitted to the Normal School of Paris. In 1853 he received the degree of doctor in letters, having presented a Latin thesis *De Personis Platonicis* and a French *Essai sur les Fables de La Fontaine*. He then turned from the career of university teaching, which was open to him, and devoted himself to authorship. His *Essai sur Tite Live* (1854) was crowned by the French Academy, and his *Voyage aux Eaux des Pyrénées* (1855) achieved great popularity.

His *Philosophes français du XVIIIe Siècle* (1856) was an attack on the system of education prescribed by the government. In 1863 he was appointed examiner in literature for the military school of St. Cyr, and in the next year professor of the history of art and aesthetics at the École des Beaux Arts. In the same year appeared his essays on English idealism with Carlyle as its exemplar, and English Positivism, with John Stuart Mill. These prepared the way for the work by which he is best known to the English-speaking world, *Histoire de la Littérature anglaise* (4 vols.). His brilliant sketch of the development of English literature and masterly criticism of its grand array of authors and their works would have sufficed to give it fame. But beyond and beneath, permeating and modifying all his research and statements, was the doctrine that the great authors, instead of being leaders of the thought of their age, were rather the product of its movement. The versatile genius of Shakespeare, the lofty verse of Milton, the correctness of Pope, the cynicism and even the madness of Swift, the romance of Sir Walter Scott, and the sweetness of Tennyson, are all attributed more to their physical and social environment than to individual originality. To the same effect he labored in his *Philosophie de l'art* (1865), in *Voyage en Italie* (2 vols., 1866), and in other works, brilliant in thought and style. In 1871 he delivered courses of lectures in England and received from the University of Oxford the degree of D. C. L. His closer views of England and its institutions were given in his *Notes sur l'Angleterre* (1872), which, like his other books of travel, has been issued in handsomely illustrated editions. Still more important than any of his preceding works was his great historical and political study of his own country, *Origines de la France Contemporaine*. To this belong *L'Ancien Régime* (1876); *La Révolution* (1878); *La Conquête Jacobine* (1881). In these works, while he depicted with unsparing hand the evils of the feudal despotism, he showed as little favor to the blood-thirsty democracy by which they were overthrown. The work, during its progress, was accepted as a partial defence of the monarchical system, and Taine, who had been rejected by the conservative Academy in 1864, just after the publication of his work on English literature, and again in 1874, was in 1878 admitted among the Forty Immortals.

TAIT, ARCHIBALD CAMPBELL (1811–1882), primate of England, was born at Edinburgh, Dec. 22, 1811, and educated at the High School there. He graduated at Glasgow University in 1827 and at Balliol College, Oxford, in 1830, where he became a Fellow and tutor. He opposed the new "Oxford movement," and with three others published a protest against Newman's famous Tract No. 90. His being in orders prevented his appointment in 1838 to the chair of Greek at Glasgow. In 1842 he succeeded Dr. Arnold as Head Master of Rugby School. While here he married and was widowed. Appointed Dean of Carlisle in April, 1850, he administered the office with much energy and efficiency; he was also an active member of the Oxford University Commission. After losing three children by scarlet fever he was

named Bishop of London in 1856, in succession to Dr. Bloomfield. In 1863 he initiated a plan to raise £1,000,000 in ten years for supplying the deficiency of church accommodations in London. After refusing the metropolitan see of York he accepted that of Canterbury from Disraeli in 1868, succeeding Dr. Longley. In this high office he displayed remarkable energy, honesty, tact, and courtesy. As a moderate Low Churchman he was disliked by the "advanced" party and continually attacked by the *Church Times*, but this he wisely disregarded. In the conflicts about ritual and ecclesiastical law his sound judgment was of great value. He presided over several important meetings, as the Pan-Anglican Synod at Lambeth, 1867; the Church Congress at Croydon, 1877; and the Conference of Anglican Bishops at Lambeth, 1878. His letter to the Evangelical Alliance at its meeting in New York, 1873, exhibited his liberal feelings. His writings are notable rather for common sense than for brilliancy or profundity. They include, besides various charges, letters, sermons, etc., *The Dangers and Safeguards of Modern Theology* (1861); and *The Word of God and the Growth of Faith*, in two parts (1863–4). He died at Croydon, Dec. 3, 1882. A sketch of his *Public Life* and a comparison between him and Archbishop Laud appeared the next year. A memoir of his wife and son, who both died in 1878, was written by W. Benham (1880), with his approval.

TAIT, PETER GUTHRIE, British mathematician and physicist, was born at Dalkeith, Scotland, in 1831. He was educated at the University of Edinburgh and at Peterhouse, Cambridge, where he was senior wrangler. He was made professor of natural philosophy in the University of Edinburgh, and is general secretary of the Royal Society of Edinburgh. He received in 1886 a medal from the Royal Society for his valuable contributions to mathematical and physical science. He is joint author with Sir William Thomson of the *Natural Philosophy* known by their name; and with Prof. Balfour Stewart of *The Unseen Universe*. He has also published *Recent Discoveries in Natural Philosophy*; *Dynamics of a Particle*; and *Quaternions*.

TALBOT, SILAS (1750–1813), naval officer, was born in Rhode Island, and at the outbreak of the Revolution was made captain in a R. I. regiment. He served at the siege of Boston, at New York city, and at Fort Mifflin, near Philadelphia. In 1778 his nautical skill was displayed in transporting Gen. Sullivan's troops from the main-land to Newport, R. I., and in capturing the British floating-battery near that town. In 1779 he armed a prize vessel, and after several exploits was commissioned as captain. He was, however, captured by a British fleet in 1780, and remained a prisoner till the close of hostilities. He purchased the forfeited estate of Sir William Johnson, on the Mohawk, and served in the N. Y. Legislature and in Congress. On the reorganization of the navy in 1794 he superintended the construction of the frigate *Constitution*, which became famous as "Old Ironsides." In this vessel he cruised in the West Indies in 1799. He resigned in 1801, and died at New York, June 30, 1813.

TALC, an important species of mineral, of unctuous feel, whence possibly its name, which is derived from the same root as English "tallow." Chemically talc is a silicate of magnesia, usually somewhat hydrated, its formula being $O_{10}Si_2Mg_3 \cdot 2H_2O$. Occasionally it makes up the mass of extrusive geological formations. In physical character it is very soft, ranking with graphite in this particular, and is used as No. 1 in the scale of hardness. Specific gravity, 2.6 to 2.8. It is found in several conditions, occasionally in an imperfectly crystallized state, but usually in compact or in foliated masses. The folia are micaceous in character, very flexible but not elastic. Talc is sometimes of pearly lustre, usually light green in color, but occasionally white or dark green. In its compact or massive

variety it is known as steatite or soapstone. Extrusive beds of this material occur in some localities of the United States, often in association with serpentine and talcose or schloritic schist. Quarries of soapstone are worked at several localities in Vermont, New Hampshire, and Massachusetts; near Philadelphia, Baltimore, and Washington, and at many other places. It is used to make stoves, ovens, and hearths, for sizing rollers in cotton factories (being unaffected by acids), as stoppers for chemical vessels, in its powdered state as a lubricant, and for slate pencils and crayons. The French chalk of the toilet and tailors' shops is a soft white sort of soapstone. It is used to some extent in the porcelain manufacture, and is an ingredient in several kinds of steam-packing. Being easily cut into figures which can be hardened by fire, it is used to imitate more valuable stones, being colored in accordance therewith. At the town of Edwards, St. Lawrence co., N. Y., is a large deposit of tale which is peculiar in having the fibrous character of asbestos. This material is crushed and pulverized, and is used for a variety of purposes, but principally in paper-making. As a filler in the manufacture of paper of all grades, except the very finest and the coarsest, it is excellent, and is preferred to the clays and other substances ordinarily used for this purpose. (C. M.)

TALLMADGE, BENJAMIN (1754-1835), colonel in the Revolutionary war, was born at Setauket, L. I., Feb. 25, 1754. The son of a minister, he graduated at Yale College in 1773, and had charge of a high-school at Wethersfield, Conn., when the war began. Entering the army as lieutenant in 1776 he rose to the rank of colonel in 1779. In September of that year he crossed Long Island Sound and surprised and captured 500 Tories. In the following May a similar exploit resulted in the destruction of British stores at Fort George, L. I. He had the custody of Major André after his capture in September, and was a member of Washington's military family. After the war he married the daughter of Gen. William Floyd (1734-1821), a signer of the Declaration of Independence, who had commanded the patriotic militia of Long Island. He settled in New York city as a merchant and in 1800 was elected to Congress, where he served for sixteen years. He died at Litchfield, Conn., March 7, 1835, having long commanded universal respect as a survivor of "the times that tried men's souls."

His son, FREDERICK AUGUSTUS TALLMADGE (1792-1869), lawyer and politician, wrote *Memoirs* of his father (1859), held many local offices, and was a member of Congress (1846-48).

TALMAGE, THOMAS DE WITT, Presbyterian preacher, was born near Bound Brook, N. J., Jan. 7, 1832. He graduated at the University of New York City in 1853 and at New Brunswick Theological Seminary in 1856. He was then ordained pastor of a church at Belleville, N. J. In 1859 he was called to the Reformed Church, Syracuse, N. Y., and in 1862 to the Second Reformed Church, Philadelphia. After seven years' service here, he became pastor of the Central Presbyterian Church, Brooklyn, N. Y. His brilliant oratory soon drew crowds, to accommodate which a new edifice of wood and iron, capable of holding 3000 people, was erected, and when it was destroyed by fire, Dec. 22, 1872, a more substantial one was built of brick and stone on the same site. It has seats for 5000 persons. The old church is used as a Lay College, of which Dr. Talmage is president. Besides gathering and ministering to one of the largest Presbyterian churches in the country, he has been a popular lecturer, a writer for newspapers, and editor of a religious weekly and a magazine. Quick in movement, often extravagant in style, and energetic in action, he readily sways an American audience. His sermons are widely circulated every week, over 600 newspapers publishing them entire. They are translated into several languages. From his sermons

and contributions to the press many popular volumes have been compiled. Among them are *Crumbs Swept up* (1868); *Abominations of Modern Society* (1872); *Night Sides of City Life* (1878); *Brooklyn Tabernacle* (1884); *Marriage Ring* (1886).

TAMMANY SOCIETY, a noted political organization of the Democratic party, derives its name from Tamanend, an Indian chief, concerning whom various legends are related. He is said to have ruled near the present site of Easton, Pa., to have signed the treaty with William Penn, and after a life of primitive piety to have died a centenarian. Towards the close of the Revolutionary war the Pennsylvania troops of Washington's command took him as their patron saint instead of St. George, and celebrated his day, May 12, with festivity appropriate to his race and the season. The warriors, decked with feathers and bucktails, having gathered around a liberty pole, "St. Tammany" came forth from a wigwam, and gave them a "talk" on courage and freedom, after which they danced and caroused. The annual celebration was retained in the American army and among the people, especially in Pennsylvania, for many years. Within a fortnight of the first inauguration of Washington at New York, April 30, 1789, William Mooney, an ardent Irish-American "Liberty Boy," took advantage of this festival to institute the Columbian Order. It was intended as a popular offset to the "Society of the Cincinnati" (*q. v.*), which had excited prejudice on account of its supposed aristocratic character and tendencies. The immediate cause of the formation of the new society was the popular reaction against the recent removal of the political disabilities of the wealthy Tories who had remained in New York city. Columbus had been selected as the patron of the order, probably in deference to Joel Barlow's once famous epic, *The Vision of Columbus*, then newly published. But the terms and usages of the society were all derived from those of the Indian tribes, and when the popular instinct transferred the honor to the Indian Tammany the leaders readily acquiesced in the change. Mooney, as "Grand Sachem" of the order, was assisted by twelve sachems, or chiefs of tribes, and the other officers were a sagamore, or master of ceremonies, a wiskin-kie, or doorkeeper, and a scribe. Pres. Washington is said to have availed himself in 1790 of the assistance of the society in entertaining a delegation of Creek Indians and negotiating a treaty with them. At this time some Federalists belonged to it, but its rules and levelling tendency soon excluded all but pronounced Republicans. The passage in Washington's "Farewell Address" referring to the danger of political "combinations and associations" has been thought to refer to the Tammany Society, and had the effect of diminishing its membership at the time.

The society had indeed become a "machine" under the direction of Aaron Burr, who, though never a member of the order, was able through his personal influence with Mooney and its other leaders to inspire and guide its movements in the political struggle in New York city. By its aid he achieved in 1799 the astonishing defeat of the careless Federalists in both city and State. His victory promptly secured for him the nomination to the vice-presidency from the Congressional caucus, but his shameless attempts to snatch the presidency from Jefferson brought him discredit with the party he had guided to success at the polls. Yet in 1804, when he sought to regain his prestige by winning the governorship of New York by a similar method, Tammany, whose members had received no benefit by his elevation, still adhered to his cause. Burr, defeated by the efforts of Hamilton, slew him and was himself ruined.

The society which he had made formidable in politics still professed to be organized for charitable purposes and obtained a charter in 1805 as the "Tammany Society, or Columbian Order." It even began a museum of natural history, which finally passed into the

hands of the great showman Barnum. But such ideas were soon discarded by its practical members. One of its main objects was the extension of the elective franchise which had been restricted in the New York State Constitution to freeholders of a certain amount of real estate. Yet actually for many years it did nothing to secure this object, its energies being absorbed in the contest with De Witt Clinton, who had at one time been its scribe but had been alienated by its subserviency to Burr, and its later alliance with the Livingston family, noted for its wealth in land. Throughout Madison's presidency there was a rivalry between him and the Clintons—"old George," the vice-president, and his greater nephew De Witt—having some elements of that between Jefferson and Burr. From Madison Tammany obtained the control of the Federal patronage, while at Albany Daniel D. Tompkins—early and late a member of the society—was now governor of the State. In 1811 Tammany had reached such financial success that it built its first hall. Its meetings had heretofore been held in taverns, and especially in Martling's Long Room, a one-story structure built for dancing parties.

After the war with Great Britain (1812-15) De Witt Clinton, who was supposed to be completely crushed by his political enemies, renewed his grand project of the Erie Canal with such vigor that the people elected him governor though Tammany showed its spite by naming an opposition candidate. The society however had gained a powerful ally in Martin Van Buren, and in a number of instances it was enabled by his shrewd management to win political advantages and even to appear more favorable to internal improvement, support of which was the ground of the governor's popularity. A general meeting in Tammany Hall in 1820 led to the State constitutional convention which in 1821 removed some of the restrictions on the elective franchise which had been one of the society's earliest grievances. The society itself was correspondingly enlarged and became too unwieldy to conduct affairs by general meetings. In 1822 a general council was therefore formed, consisting of three delegates from each of the eleven wards. This council, or general committee as it came to be called, gradually assumed the powers of the general meeting, and the society merely preserved its existence for ownership of the hall and formal celebrations.

Before De Witt Clinton died in 1828 he had again been elected governor of New York in spite of his able and vigilant foes, but thereafter Tammany Society worked in harmony with the Democratic governors for many years. In 1833 New York city had obtained a charter making the mayor elective, and a change which produced increased political activity among the people.

The "Equal-rights" party struggled with the Tammany managers for control of the general meeting. An incident of the meeting in 1835 gave the name "Locofoco" to these innovators and the name was afterwards extended to the whole party. Tammany was defeated more than once by the Locofocos in local contests, but in 1839 harmony was re-established. The Democrats however were defeated in 1844, when James Harper was elected mayor by the American party. When the Democratic party of the State divided into the "Hunkers" and "Barnburners" (*q. v.*) a somewhat corresponding division took place in Tammany Hall between the "Hards" and "Softs," the former being the office holding faction. Though they united in electing Fernando Wood mayor in 1854, the internal struggle continued. In 1858 with the regular Tammany nomination he was defeated and in the next year in opposition to it he was elected. He began the system of lavish municipal expenditure which had such disastrous results soon after the civil war.

In 1860 the first Tammany Hall was reconstructed, but on July 4, 1867, the corner-stone of the present building on Fourteenth street between Irving Place and Third avenue was laid and Gulian C. Verplanck de-

livered the oration. Exactly one year later the building was opened to receive the Democratic National Convention which there nominated Horatio Seymour and Frank P. Blair. The building is of red brick with white marble trimmings. It has a wide front and is three stories high. A circular pediment bears the inscription "Tammany Society," with the dates 1789 and 1867. Between these in a niche is the marble statue of an Indian warrior, twelve feet high.

The delegates to the general committee originally came from each ward, but in 1843 from each election district and finally from each precinct. The body thus grew from 33 members to over 1400, and from having management of the campaigns to having entire control of the political action. The society still owned the hall and held formal celebrations but had hardly the semblance of power. Even the general committee was too unwieldy for its nominal task and a "committee on organization" did the serious work. The chairman of this committee was the "boss" of the Hall.

After the civil war came a succession of "rings" controlling the action of the Hall. The most notorious of these was the corrupt combination formed by Wm. M. Tweed, A. Oakey Hall, Richard B. Connolly, and Peter B. Sweeny. Having obtained from the State Legislature an amended city charter, which gave them as office-holders irresponsible control of the city finances, they doubled the annual expenditure, and increased the bonded debt by more than \$100,000,000. A standing army of voters was obedient to their will exercised through the agency of Tammany Hall. After years of wholesale speculation and embezzlement, a clerk revealed to the *New York Times* the fraudulent accounts. Even after their exposure, Boss Tweed could arrogantly ask, "What are you going to do about it?" A committee of seventy, with the aid of Charles O'Connor, Samuel J. Tilden, and other prominent Democrats, undertook to battle with the ring and by heroic efforts succeeded in ousting its members from office and driving them into exile or into prison.

Yet Tammany Hall survived even this catastrophe. In 1873 it passed into the control of John Kelly, a nephew of Cardinal McCloskey, who had assisted in expelling the Tweed Ring. Personally pure and without ambition for office, he was an astute and successful political manager. The new nominations were of a higher order than had been customary for many years. But the growth of the Independent vote and the various Democratic secessions from Tammany had diminished its power. As economic questions again became prominent, the Democratic party moved in the direction of Free Trade, while Tammany inclined to a protective tariff, claiming room for that policy under the shield of Democracy. In 1879 Tammany bolted from the action of the State convention and made John Kelly its candidate for governor, thus defeating Lucius Robinson. In 1880 its influence was used against Gen. Hancock in the Presidential campaign. It endeavored to prevent Cleveland's nomination and election in 1884, but without success. Kelly's health failed and he was obliged to withdraw from political work. He died June 1, 1886. No one has succeeded to his power. But Tammany Hall still remains the most compact organization of the Democratic party in New York city. Hon. Abram S. Hewitt, though not belonging to it, was elected mayor of New York on its nomination in 1886, but, as his subsequent course gave offence to its members, he was defeated when a candidate for re-election in 1888, and H. J. Grant, Tammany's candidate, secured the prize. (J. P. L.)

TANEY, ROGER BROOKE (1777-1864), chief-justice of the United States, was born in Calvert co., Md., March 17, 1777. He belonged to a Catholic family, which had settled there a century earlier, and always adhered to his ancestral faith. He graduated at Dickinson College in 1795, and was admitted to the bar in 1799. In the next year he was a member of the Mary-

land house of delegates, and in 1816 of the State Senate. His reputation as a lawyer steadily increased, especially after his removal to Baltimore in 1823. He had originally been a Federalist, and was personally opposed to slavery, but in the new alignment of parties, which took place during John Quincy Adams' administration, Taney took the Democratic side. He was appointed attorney-general of Maryland in 1827, and four years later Gen. Jackson called him to be U. S. attorney-general, and found him an able assistant and trusty adviser. When the President, after vetoing in 1832 the bill for renewal of the charter of the U. S. Bank, decided further that the bank and its branches should no longer be government depositories, Duane, then secretary of the treasury, with a well-grounded apprehension of the result of entrusting the funds to State banks of various and uncertain degrees of financial soundness, refused to execute the order. He was, therefore, removed, and Taney, who had advised the scheme, was appointed in his place. The nomination was held in suspense by the Senate for nine months, and finally rejected, though Taney had meantime been acting as head of the department. Jackson's regard for him was shown again in 1835, when he nominated Taney first as associate and afterwards on the death of John Marshall as chief-justice of the Supreme Court. There was still opposition in the Senate, but within three months Taney was confirmed. He had now attained the height to which his ambition had early aspired. The feelings of awe and veneration which, during the long career of Chief-Justice Marshall, had gathered around the Supreme bench, were preserved during several years of Taney's term.

Two great cases bearing strong impression of his mental qualities illustrate his powers and balance of mind at its period of most full development and in its days of declining strength. Both of these cases involved fundamental questions relating to the structure of our system, the one as it regards its political and the other its civil aspects. One of these cases arose out of what is known as the Dorr rebellion, which was an attempt to change the constitution of Rhode Island by popular authority without the assistance and concurrence of the then existing government of that State. The other case was that of the status of a slave who had been carried from a State in which slavery existed to a place where that institution did not exist and returned to the first-mentioned State, where the freedom of the slave was claimed on the ground that he had been taken by his master to a State in which slavery had no existence. In the first case the decision of the court rendered by the chief-justice was strictly confined to the necessities of the questions presented, while in the other the opinion of the chief-justice went beyond those necessities to define a grave constitutional question that involved the balance of powers between the national government and the States.

That the attempt to change the constitution of Rhode Island, independent of any concurrent action of the existing government, was revolutionary in its nature appears quite clear. That the government sought by such means to be established was not in fact established so as to be capable of being regarded as a *de facto* government appears by the statement of the case, and is a recognized historical fact. The case in the opinion of the chief-justice turned upon the authority of the President upon the application of the government of a State to use the military power of the United States to quell insurrection against such State authority, in such a case the court being concluded by the action of the President on such an application. As in cases of that character it may happen that the actual existence of the government making such a demand of the President may be disputed as between two conflicting claimants to such authority the conclusion of the court would appear to sustain the

idea that the determination of such a question belongs to the President, and his decision is binding upon the court. No higher assertion of national authority can be made than that which confers upon the national government authority to determine the controversies between a State and its citizens as to the rightful exercise of State authority, and where such authority is accorded to the national executive so as to bind the judicial power, the assertion of national prerogative against State authority is as vigorous as the most ardent advocate of the national idea could demand.

But the greater the manifest regard of the American people for its highest tribunal the more anxious were the pro-slavery politicians to obtain the support of this department of the government for the movement for the extension of slavery. The case of DRED SCOTT (*q. v.*) furnished the opportunity, and Taney, with the majority of the court, yielded to the pressure. The decision which refused Scott, as a negro, any standing in a U. S. court, and the offensive dictum that, in the opinion of the framers of the U. S. Constitution, negroes had "no rights which white men were bound to respect," was published March 6, 1857, immediately after Pres. Buchanan's inauguration. It was evidently intended by its authors to extinguish all opposition to the progress of slavery in the national domain; its only effect was to rouse in the North a fiercer and more determined antagonism to the domination of the slave power. During the ensuing years of political strife, secession, and civil war Taney remained a reluctant witness to the steady progress of a political revolution, which finally overthrew slavery even in Maryland. He faithfully performed all the duties of his office as he understood them, but he bewailed the loss of much of its former glory. His views even brought him into conflict with the military authorities, and he was compelled to recognize the truth of the proverb, "*Inter arma leges silent.*" He died at Baltimore, Oct. 12, 1864. His life ended before the conclusion of the great struggle that restored the strength of the national authority that had been weakened by the decision in the Dred Scott case, and the country truly mourned the death of an eminent judge and worthy man who was equal to the demands of his great office in the height of his mental powers, but in the end could not resist the course of nature and of revolution. See his *Life* by S. Tyler (1872).

TAPPAN, ARTHUR (1786-1865), merchant and Abolitionist, was born at Northampton, Mass., May 22, 1786. His father, Benjamin Tappan, had been noted for his patriotism during the Revolution. Arthur, after receiving a common-school education, entered on a mercantile career at Boston. With his brother, Lewis, he engaged in importing dry-goods, and resided for a time at Portland, and afterwards at Montreal. The war of 1812 compelled him to leave Canada, and he settled in New York. Here his activity and liberality found wide scope in founding and contributing to religious and benevolent enterprises. The American Tract Society, the American Bible Society, and various colleges and seminaries were fostered by his generosity. In 1828 the Tappan brothers founded the *New York Journal of Commerce*, with Horace Bushnell as one of its editors. Arthur was roused to activity in the Abolitionist cause by the persecution of William Lloyd Garrison, whom he rescued from a Baltimore jail by paying his fine. In 1833 he called at his own house a meeting for the formation of an anti-slavery society, and in the same year was made the first president of the American Anti-slavery Society. When threatened with the loss of Southern trade the brothers replied that their goods but not their principles were for sale. In 1834 Arthur's dwelling-house was attacked and pillaged by a mob, and the brothers' store had to be defended by arms. Yet they continued to give liberally to the Abolition cause until in 1835 their warehouse was burned. By

severe struggles the firm was able to maintain its standing, even during the panic of 1837. When the leaders of the Anti-slavery Society directed their attacks on the Christian churches as upholders of slavery Arthur Tappan protested, and finally withdrew from being its president. In 1841 his business partnership was dissolved, and in the next year he failed, but with unflinching integrity caused all his personal property to be sold for the benefit of his creditors. He was then employed by his successors in the business until 1849, when he joined his brother in his enterprise, the first mercantile agency in the United States. In old age he resided at Passaic, N. J., and finally at New Haven, Conn., where he died July 23, 1865. His brother Lewis (1788-1873), who had been closely associated in his business and philanthropic labors, wrote his *Life* (1870).

Another brother, BENJAMIN TAPPAN (1773-1857), in his youth learned engraving and portrait painting, but afterwards studied law and moved to Ohio in 1799. There he was a member of the Legislature, afterwards judge, and in 1833 was appointed by Pres. Jackson U. S. district judge. In 1839 he was elected to the U. S. Senate as a Democrat, but in 1848 he took part in the organization of the Free Soil party. He died at Stenbenville, Ohio, April 12, 1857.

TAPPAN, HENRY PHILIP, metaphysician and educator, was born at Rhinebeck, N. Y., April 23, 1805. He graduated at Union College in 1825, studied theology at Princeton, and became associate pastor of a Reformed church at Schenectady. In 1828 he was called to a Congregational church at Pittsfield, Mass., and in 1832 was made professor of moral philosophy in the University of the City of New York. After holding this position six years he conducted a private school for 14 years. Meantime he had prepared his metaphysical treatises, commencing with a review of *Edwards on the Freedom of the Will* (1840), and expanded into *The Doctrine of the Will Determined by an Appeal to Consciousness* (1840), and *The Doctrine of the Will Applied to Moral Agency and Responsibility* (1841). He also published *Elements of Logic* (1844), which was afterwards revised. In 1852 he was chosen first chancellor of the University of Michigan, and made a tour in Europe, recorded in his book, *A Step from the New World to the Old* (1852). Another visit to Europe enabled him to secure an excellent equipment for the university observatory, and the services of Prof. Francis Brünnow as astronomer. The university soon attained great prosperity, and became the model for similar institutions in other States. In 1863 Dr. Tappan resigned and went to Europe.

TAR is a result of the destructive distillation of organic substances, especially wood and coal. Where wood is plentiful (p. 62 *Am. Rep.*) tar is produced by burning the wood for that purpose; and in some of the pits where charcoal is produced an arrangement is made by which the tar is collected. From wood-tar there is further distilled wood vinegar, or pyroligneous acid, from which is also procured wood naphtha. In the United States nearly all of the wood-tar comes from North Carolina. Wood tar is produced by the smothered burning of the long leaved pine deadened by fire. A tar-kiln is commenced by scooping out of the ground a saucer-shaped foundation, making a hole in the middle, and thence running a wooden spout outside the rim of the foundation. The wood is split into billets 3 or 4 feet long and about 3 inches in diameter. The billets are stacked in the centre hole and piled upward, each upper stick lapping a little over, thus giving the finished pile the appearance of an inverted cone. Logs of wood and green twigs are then piled around, and the whole covered with earth. The fire is lighted at the top caves, and the distilled tar runs out through the spout. A kiln yields 50, 100, or more barrels of tar, according to its size. Large iron retorts have been used, but the product is not suffi-

ciently greater or more cleanly to, pay for increased cost.

Coal-tar was for a long time a troublesome product of gas-works, no useful application of it being known to any great extent. Later it was used as a covering to protect iron-work exposed to the weather; and the pitch obtained by distillation was found, when mixed with earthy matters, to be a good substitute for the natural product, asphaltum, used for artificial pavement, water-tight covering for roofs, etc. Finally tar distillers learned to extract from it crude naphtha, and also light oily fluids. The pitch, by continued distillation, was made to yield more oily matters. Crude naphtha is now purified with it; by taking one-tenth its bulk with concentrated sulphuric acid, adding when cold 5 per cent. of peroxide of manganese, and distilling off the upper portion a rectified naphtha is obtained, which easily dissolves India rubber. Mixed with wood-naphtha it produces a powerful solvent of various resinous substances useful in making varnishes. Still further purified, the liquid benzole is obtained, used extensively as an illuminating agent. The light essential oils, as well as the heavier ones, possess antiseptic properties, which render them valuable for preserving wood from decay. Among the other products obtained from coal-tar are carbolic acid and the aniline color.

(F. G. M.)

TARIFF (from *Tarifa*, the name of the Spanish port at which the Moslem rulers of the country levied duties on goods passing through the Straits of Gibraltar) is a list of the duties levied by any country upon exports and imports, especially the latter. In the United States question of free trade or protection has centred around the legislation to increase or lower these duties; and the tariff controversy has stood next to that over slavery, and above that over the currency, as a source of party divisions.

The word was in America adopted from English usage. The early English tariffs were prohibitory in their provisions. They absolutely forbade the importation of articles which the Parliament agreed should be made at home. It was not until the reign of Queen Elizabeth that the use of the tariff as a source of revenue to the government may be said to have begun. Heretofore the sovereign had profited by it only through selling dispensations from its provisions to favored merchants, such as Napoleon did during the continuance of his Continental system, but without the concealment he practised. But even the tariffs of a later date contained distinct prohibitions, and that of 1819 still continued the prohibitory method under the cover of duties placed so high as to effect the exclusion of the article. In the American tariff there are no prohibitory duties except on some articles—chicory, shoddy, doctored wines, etc.—which are excluded for other than merely commercial reasons.

After American independence had been secured the power to legislate with reference to duties on imports passed to the thirteen States of the very imperfect Union of 1777-89. Each of them adopted such a tariff as suited its ideas and circumstances, and the lines of custom-house collections sundered them from each other. This at one time seemed not unlikely to result in the dissolution of the Union into its original elements, as quarrels sprang up in all quarters, and some States were not above adapting their regulations to foster smuggling into the territory of their neighbors. The Constitution of 1787-89 transferred this power to the new national government, and on July 4, 1789, James Madison reported a tariff law, which expressly stated among its objects "the encouragement and protection of manufactures."

While the Federalist party continued in power the only changes made in this tariff were in the increase of its duties; but on the accession of the States Rights party in 1801 there was a cessation of this constant adaptation of the duties to the freshly discovered needs of industry. No duty, however, except that on

salt, was repealed or even reduced, and when the second war with Great Britain occurred the duties were doubled until three months after the cessation of hostilities. In this first period of our tariff legislation there was entire agreement among our statesmen as to the wisdom and propriety of the protective policy, Washington and Hamilton on the one side, and Jefferson and Madison on the other being of that mind. At the same time there was prevalent a very moderate idea of what the country should undertake in the way of supplying itself with manufactures, and the tariff omitted or placed under a mere nominal duty some of the most important staples.

It was the war of 1812 which at once destroyed the previous unanimity of view and raised the ideas of the protectionists as to the necessity and feasibility of a national manufacturing system, which would make the country independent of foreign supplies in case of another war. The war itself acted as a prohibitory tariff on British goods, and forced Americans to begin making for themselves what they had been buying abroad. It created the factory system on American soil, and thus began the supersession of those household manufactures which had clothed our people. At its close the people of the Middle and Southern States were pretty well united in the belief that it would be a mistake to allow the industrial gains of the war to be sacrificed to the competitions of cheaper labor and more abundant capital in Europe; and the tariff of 1816 was enacted, in the face of the resistance of New England, with that purpose. It proved quite inadequate, as its duties were too low to meet the new conditions as to cheapness of production and of transportation in Europe, and it was reinforced by higher duties in 1824 and 1828, the latter being the highest tariff ever enacted in this country.

In the meantime the South and New England had changed places as regards the principle of a protective tariff, the former because manufactures were found impracticable in slave States, the latter because it had begun to divert its capital and the ingenuity of its people from an exclusive devotion to commerce and shipping to manufactures. In both 1824 and 1828 the amount of opposition from the South had increased, and in the next decade that section had become almost unanimous for free trade. This was especially the case after England in 1832 removed the protective duty she had levied upon our cotton for the benefit of her East and West Indian dependencies, as she had found that our longer and finer staple was indispensable to her spinners if they were to compete with those of America. From that time the Southern planter no longer depended upon the Northern mills for a market for his crop; and he entered into a free trade alliance with the English loom-lords for mutual advantage.

In 1832 the tariff was revised, and many of its duties were reduced to conciliate the growing opposition, but the result was so little acceptable to the South that South Carolina, with some moral support from her neighbor States, undertook to "nullify" the tariff laws of the United States, and to prevent the collection of their duties in her ports. By the firmness of Pres. Jackson this danger was averted; but for political reasons a further revision was had in 1833, and it was agreed that there should be a progressive reduction of duties until by 1842 none of them should stand higher than 20 *per centum ad valorem*. This reduction proved disastrous to our manufactures, and was a leading cause of the panic of 1837, which caused a political revolution and brought the Whigs into power in 1841. The tariff of 1842 ranks in protective efficiency beside that of 1828, and it caused a revival of American industries in all directions.

In June of 1846 Great Britain repealed its corn laws and abandoned the protective principle, after enjoying its benefits for more than 500 years. It was predicted and confidently expected by Mr. Cobden and his associates in the League that this would be followed by the

speedy adoption of free trade in all parts of the civilized world. In the United States it did lead to the tariff of 1846, which placed almost all duties at one of three *ad valorem* levels of 10, 20, or 30 per centum, instead of the specific duties of the tariff of 1842. It is notable that Mr. Calhoun suggested as preferable the sliding-scale method, by which duties should rise as prices fell and *vice versa*, as tending to reduce instead of increasing fluctuations in prices, and also to give American manufacturers a better chance. The tariff operated very unevenly upon our manufactures, as some of them still enjoyed ample protection, while others, especially those of iron and woollen goods, were greatly depressed, and in many cases ruined. Presidents Taylor and Fillmore urged a return to protective duties on the ground of the harm the industries of the nation had received; but the slavery controversy occupied the time and attention of Congress to the exclusion of almost everything else. In 1857 the Southern leaders even carried an amendment to a bill for a slight alteration in tariff methods, which reduced the duties by 25 per centum. This was followed by a panic, of which it was a chief cause; but although Pres. Buchanan urged the revision of the tariff in the interests of our native industries his recommendations passed unheeded, until at the close of his administration the withdrawal of Southern senators and representatives of the seceding States left the Republican party with a majority in both branches of Congress, and this led to the adoption of the protective tariff of 1861, called the Morrill Tariff from its chief author, Hon. Justin D. Morrill.

When this tariff was adopted six States had declared themselves out of the Union, Jefferson Davis had been inaugurated as President of the Confederate States at Montgomery, and nine days afterwards the Constitution of the Confederacy was adopted, declaring that its Congress should have no power to impose protective duties on imports. The tariff of 1861 was a war measure both in the sense of levying many duties for the sake of a large revenue to the national government, and in the sense of aiming to put the country in a posture of defence in case of any complication with Europe. It was altered by the imposition of higher duties in the session of 1861-62 and in that of 1863-64, and in a minor degree at various other times. Throughout the period protection and revenue were equally kept in view, and through its operation both these were secured. The manufacturing industries grew and the natural resources of the country were developed with such rapidity, and the losses of population were replaced by immigration to such an extent, that the terrible waste of war was hardly felt in an economic sense, and the country came out of the most gigantic civil conflict known to history richer and stronger than when it began.

With the close of the war and the reduction of the burdens of national indebtedness, the work of bringing the tariff from a war to a peace basis began. First, revenue duties, such as those on tea and coffee, were repealed. Then as the internal revenue taxes were repealed, duties raised to compensate them were reduced correspondingly. This was effected especially in 1870; but in 1883 a general revision was effected after a thorough investigation of the workings of the tariff through a national commission. But the accumulation of a surplus of revenues in the national treasury brought up the question of a further revision and reduction, and the majority of the House in the Fiftieth Congress committed itself to that policy by passing the Mills Bill, so called from its author, Hon. R. Q. Mills.

As Pres. Cleveland had urged this policy very strongly upon Congress in his annual message of December, 1887, and was known to have expressed his approval of this particular measure, and became a candidate for re-election to the presidency in 1888, the election campaign of that year was accepted on both sides as turning upon this issue. An especial feature

of the Mills Bill was the transfer of raw materials of manufacture to the free list. This change may be regarded as having secured to Mr. Cleveland the votes of two manufacturing States in the North. But as he got no more than these, and as the agricultural States of the North-west showed their resentment of this proposal by their votes, the Mills Bill and the policy it embodies may be said to have shared in Mr. Cleveland's defeat. In those sections of the South where manufactures had struck root since the abolition of slavery there was a notable falling-off in the vote of the Democratic party, and both Virginia and West Virginia gave Mr. Cleveland only small pluralities. At the same time the Protectionists secured majorities in both branches of the Fifty-first Congress, thus enabling them to proceed with the work of reconstructing the revenue legislation of the country in accordance with their principles.

In the later phases of the tariff controversy the opponents of the protectionist policy have shown themselves very unwilling to be called free traders. Some of them seem to think they are entitled to repudiate this now unpopular name because they do not wish to abolish the custom-house, as do John Ruskin and Henry George, but rather to maintain a tariff for revenue. But this wish is not in the slightest degree inconsistent with the idea of free trade, in the well-ascertained and historical sense of that word. A tariff which should impose no duty calculated to divert any part of the labor and capital of the country into a channel in which they would not flow otherwise is a free trade tariff, however high its duties, or however large a share of the national revenue may be derived from it. Such a tariff will either levy duties only on such articles as cannot be produced in that country, or it will compensate the duties upon other articles by excise taxes upon the domestic product of equal amount. Under such a tariff trade would be as "free" as if there were not a custom-house in the whole country.

More legitimate is the objection to the term free trade in the case of those who say that while they believe in free trade principles, they recognize the vested rights which have grown up under the protective tariff, and they would do nothing to injure the manufactures thus called into existence, while they would move slowly but steadily towards a system of "industrial liberty," and would refuse to vote for any further extension of protection either in the imposition of new duties or the raising of old ones. But this species of "revenue reformer" is rarely met with, and has not a single known representative among the economists or the statesmen of the country.

The protectionist principle is not limited to any method of application. If it were possible to accomplish the same end by premiums or exemption from taxation or guarantee of profits, there would be no objection to the substitution of those methods. But it is found in practice that each of these is attended with difficulties which do not attend the adoption and enforcement of a protective tariff.

There are three methods of levying the duties of a tariff: (1) By taxing imports a given percentage of their value, and ascertaining this by the invoices, or by the judgments of experts, or both. This is objectionable because it tends to intensify all variations in prices, to put a premium upon false statements, and to give the domestic producers the least protection when he needs it the most, viz., in a time of low prices. (2) By fixing an average price for the article and taxing it so as to bring the imported article up to that price. Under this arrangement the tax disappears when prices rise above the average, and increases in proportion as they fall below it. This was the method of the English Corn Law of 1815. It obviates most of the objections to *ad valorem* duties, but would require constant readjustment as the progress of methods of production lowered the cost. (3) To levy

the duty by number, weight, or bulk of the imported article, thus dispensing with invoices, oaths to their accuracy, and other encouragements to perjury. This is the method of the English tariff, but that of the United States attempts a most unhappy combination of this with the *ad valorem* method. (R. E. T.)

TASCHEREAU, ELZEAR ALEXANDER, cardinal and archbishop of Quebec, was born Feb. 17, 1820, at St. Marie de la Beauce, Quebec. He is of distinguished French origin, his father having been Jean Thomas Taschereau, Judge of the King's Bench, Quebec, while some of his ancestors held even more prominent positions. After studying at the Quebec and Grand Seminaries, he, in his seventeenth year, proceeded to Rome, where he received the tonsure. Returning to Quebec, he pursued his theological studies, and in 1842, though under canonical age, was ordained priest. Shortly after his ordination he was appointed to the chair of philosophy in the Grand Seminary, which post he occupied for twelve years. While holding this office he endeared himself to his co-religionists and many others by his voluntarily acting as nurse and spiritual comforter to the many Irish emigrants who, driven from their home by famine, had been taken down by malignant fever during the voyage and landed on Grosse Isle, in the St. Lawrence River, thirty miles below Quebec, which soon became a mass of loathsomeness and pestilence that gradually converted it into a cemetery. The heroic ecclesiastic was himself stricken down and narrowly escaped death. In 1851 he became professor of theology in the seminary, and in 1854 he again visited Rome, where he remained two years studying canon law, and received the title of Doctor of Canon Law. On his return to Quebec, he held in succession the offices of director of the Lower Seminary, of director of the Grand Seminary, of superior of the seminary and rector of Laval University, serving also as a member of the Council of Public Instruction for Lower Canada. On his return from a third visit to Rome, he was, in 1862, appointed vicar-general of the diocese of Quebec. In 1870 he revisited Rome as secretary to Archbishop Baillargeon, of Quebec, while attending the Vatican Council. On the archbishop's death in this year Doctor Taschereau was appointed conjunct administrator of the affairs of the arch-diocese, and in the spring of 1871 was consecrated archbishop. His visits to Rome have been frequent, and when last there, in 1887, he was presented with the cardinal's hat, being the first Canadian on whom this dignity has been conferred.

TATNALL, JOSIAH (1796-1871), Confederate naval officer, was born near Savannah, Ga., November, 1796. His father, bearing the same name (1762-1803), was then a U. S. Senator, and afterwards was a brigadier-general of militia and governor of Georgia. The son entered the navy as midshipman in 1812 and had some active service near Norfolk in the next year. He was with M. C. Perry on the African coast and with Porter in his expedition against West Indian pirates. During the Mexican war, in 1847, he took part in the attacks on Tampico and Vera Cruz. In 1856 he was flag-officer of the East Indian squadron, and on one occasion fired on Chinese who were repelling a British attack. When Georgia seceded he resigned his command and hastened to Savannah where he gathered a fleet of gun-boats to defend Port Royal, S. C., against Commodore Dupont's expedition. He had command of Norfolk in 1862 and when the Merrimac, altered into the iron-clad Virginia, was disabled in her famous fight with the monitor, Tatnall ordered her to be destroyed. During the rest of the war he had command at Savannah, and at its close went to Nova Scotia. He soon returned however and was made harbor-master. He died June 14, 1871.

TAUNTON, a city of Massachusetts, county-seat of Bristol co., is on Taunton River, 34 miles S. of Boston. It is at the junction of the Old Colony Railroad with other roads. It has a court-house, city-hall, 3 national banks, 2 savings banks, 20

churches, a high-school and several good schools, 1 daily and 2 weekly newspapers, and the State lunatic asylum. The industrial works comprise locomotive-works, copper-works, 10 foundries, cotton-mills, and factories producing nails, tacks, screws, jewelry, britannia ware, etc. There are also ship-yards and brick-yards. Taunton was settled in 1639 and became a city in 1864. Its population in 1880 was 21,213.

TAXATION. The United States furnish an excellent field for the study of the practical operation of methods of taxation, in p. 85 (p. 91 Am. Rep.) that there are in this country forty-eight separate governments besides that of the nation, which have the right to determine the methods in which they will levy upon the resources and the extent of the people for public purposes, only ten of them being in any way restricted by any superior authority in this respect. The legislation of the ten Territories, which are States in the making, is subject to the revision of Congress. The Legislatures of the thirty-eight States are limited only by the provisions of their own constitutions and of that of the United States. The national government is limited only by the latter.

The national government is the only one whose duties and resources are co-extensive with the nation. Before the Constitution of 1787 was adopted it had no powers of taxation, and could only assess the States to obtain money for its necessary expenses in conducting the wars and managing the diplomacy of the country. The proposal to extend to it the power to levy taxes on imports, as much for the sake of a general system of protection to home industry as to make its treasury independent of that of the States, was defeated by the negative vote of New York. This fortunate refusal precipitated negotiations for the formation of "a more perfect union," and the new Constitution conveyed to the national Congress "power to collect taxes, duties, imposts, and excises, to pay the debts and provide for the common defence and general welfare of the United States," and to "borrow money on the credit of the United States." But this large grant was accompanied by decided restrictions. The first is that "All duties, imposts, and excises shall be uniform throughout the United States." The second, that "No capitation or other direct tax shall be laid, unless in proportion to the census or enumeration" elsewhere provided for. The third, that "No tax or duty shall be laid on articles exported from any State. No preference shall be given, by any regulation of commerce or revenue, to the ports of one State over those of another." On the other hand it is provided that "No State shall, without the consent of the Congress, lay any imposts or duties on imports or exports except what may be absolutely necessary for executing its inspection laws; and the net produce of all duties and imposts laid by any State on imports or exports shall be for the use of the treasury of the United States; and all such laws shall be subject to the revision and control of Congress." The interpretations of the Supreme Court have determined (1) that Congress has no power to levy duties on exports under any circumstances; (2) that the restriction upon the power of direct taxation does not apply to an income tax, that being a form of direct tax which the authors of the Constitution could not have had in mind; (3) that no State may tax the "instrumentalities" which the Federal government deems proper to create or employ for carrying out its purposes, such as property in the debt of the United States.

The grant of power thus conveyed has proved much more extensive than its authors contemplated. In fact it has transferred to the national government all the popular and easy forms of taxation, as it possesses not only the sole right to levy import duties, but the sole power to collect excise duties also. The attempt of any State to collect revenue from the makers of any commodity would only result in the transfer of its manufacture to other States. At the same time the jealousy

of the States at the time of the adoption of the Constitution prevented any equally extensive transfer of the duties and responsibilities of government to the nation. Thus we have a national government possessing the most ample revenues, but in time of peace doing less for its people than any other national government of the civilized world. The costs of maintaining the national executive and his cabinet, Congress, the treasury, the comparatively insignificant army and navy, the post-offices, the system of Federal courts of extremely limited jurisdiction, and the tax-collecting machinery itself make up the necessary expenses of the national government. To these it voluntarily, and in the face of protest from the friends of States' rights, has added outlays for the construction of internal improvements, harbors, grants for education, and various minor expenditures. And in addition to its revenue from taxation, it long derived a revenue from the sale of lands on the public domain, and still counts that among its minor sources of income. Under the ordinary working of the Constitution there is a vexatious disproportion between constantly swelling revenue and restricted possibility of expenditure.

This anomaly did not at once appear after the adoption of the Constitution, nor for several years later, as the United States government was burdened by a considerable debt, incurred in the prosecution of the war for independence, and, through the influence of Alexander Hamilton, was induced to assume the war debts of the States. But as early as 1806 Pres. Jefferson announced to Congress the approach of a time when the revenue would be in excess of the constitutional wants of the government, although all the excise taxes enacted in Washington's administration had been repealed in 1801. As in his view it would be unwise to reduce the tariff in order to reduce the revenue, he proposed that the powers of Congress be enlarged by the amendment of the Constitution, so as to enable it to undertake a great system of internal improvements.

The outbreak of another war with Great Britain both postponed the appearance of a surplus of revenue and forced the re-enactment of the excise taxes. But in 1829 we find Gen. Jackson, in his first message to Congress, again announcing the approach of a surplus, and proposing that it be distributed among the State governments in proportion to population. After a futile attempt of the Whigs under Mr. Clay's leadership to distribute the specific revenue from the sale of lands, a law proposed by Mr. Calhoun was passed in 1836, and signed by Pres. Jackson, "deposing" with the States in quarterly instalments the surplus in the national treasury.

Before the third of the contemplated instalments had been made, the business depression of 1837, and the losses of government money through the failure of the State banks to which Pres. Jackson had transferred it, compelled the treasurer to stop payment. In this course he was sustained by Congress, which suspended the distribution law. In recent years the State of Virginia has sued for this fourth deposit, but was non-suited because the court upheld the validity of the suspending law. Of the three deposits made under the law of 1836, most of the States made wise and fruitful use. The common schools of many of them draw revenue from the fund to this day. But in some States there prevailed ideas of financial management now happily obsolete. Thus the State of New Hampshire divided it up among its citizens, while levying the usual taxes for the support of the State government.

In the interval between the panic of 1837 and the outbreak of the war there was no surplus, partly because of the war with Mexico and partly because of the bad financial management, which left a debt of \$61,140,496 on the country in 1860, some of it paying twelve per cent. interest. Of course the expenses of the war and the pressure of the debt prevented the

accumulation of a surplus in the twenty years that followed it, although the tariff for many years was full of duties for revenue as well as protective taxes, and the system of excise taxes was revived with a thoroughness never known before. But the refunding operations of the treasury having put a large part of the debt out of reach for redemption at par, by 1857 it was found that in spite of the repeal of most of the taxes imposed for a war revenue, and repeated reductions of the tariff and the repeal of all merely revenue duties it contained, that the income of the government was becoming much in excess of its legitimate outlays. This at once made the surplus a question of national politics. The free trade party proposed to retain the excise taxes on alcoholic liquors and tobacco (the only survivors of the general repeal), and to effect a reduction of the revenue by enlarging the free list of the tariff and by a very general reduction of duties on imports. The protectionists favored a reduction of duties only so far as it would not impair the protective character of the tariff, and proposed the repeal of the excise taxes on tobacco and on alcohol used in the arts, and even, if necessary, the entire abolition of excises, as in 1801. A third proposal is to return to the policy of 1836, leaving the issue between free trade and protection to be decided on its own merits, but giving to the States the surplus of revenue from such taxes as the national government believes it can collect without unduly burdening the people, whether these come from a revenue tariff or a tariff for protection to home industry, or from either of these, together with a system of excise taxes on articles whose use it is desirable to discourage. The advocates of this plan would connect with this distribution of the surplus conditions as to its expenditure, such as have accompanied grants of money and lands to the States for the promotion of education or the construction of railroads. They would require its use (1) for the promotion of education and the abolition of illiteracy; (2) the payment of State debts with accumulated interest, without regard to acts of repudiation passed by any State; (3) to the relief of the burdens of local and State taxation.

The problem devolved upon the States and their subordinate governments of collecting sufficient revenue for the cost of the multifarious duties they have to discharge has been solved in as many ways almost as there are States. An excellent summary of their methods will be found in Prof. Richard T. Ely's work on *Taxation in American States and Cities* (New York, 1887). It has been a favorite idea with our legislators that natural equity demanded the equal taxation of every kind of property, without regard to the likelihood of injuring the community by driving industries to localities more favored by the tax laws, and also without regard to the enjoyment of much greater favors from the community by some industries than by others. Equally indifferent have been the laws of many States to the practicability of collecting certain taxes; and bonds of foreign corporations held within the State and other equally intangible forms of personal property have been taxed on a par with real estate, thus offering a premium on the easy evasion of the laws. In this respect the tax system of Pennsylvania has generally been regarded as superior to that of the States generally, which is due to the fact that in no State have the principles of economic and fiscal science had so many keen and practical students.

While it is in the highest degree desirable that the incidence of taxation should approximate to equality throughout the Union—a point most carefully guarded by the Constitution as regards the national taxes—this is the respect in which the differences have been most striking and harmful. Of course in the newer and poorer States of the Union the rate of taxation *per capita* must be much lower than in the older and wealthier commonwealths. But we find that even among these older States there are differences out of all proportion to the differing wealth of their people.

Thus in 1880 the tax-rate in Massachusetts was \$16.20 a head, but less than \$9 in Pennsylvania, for both the expenses of the State and those of its local and subordinate governments. The chief reason of this is found in the difficulty of raising an adequate revenue by direct taxation, which leads State and local governments to skimp the work of government, to be content with inadequate schools and wretched roads, and to regard "economy" as the one virtue in fiscal management. To this policy the New England States generally have been honorable exceptions, and Massachusetts especially so, but at serious cost to themselves. Many of the smaller industries, and those not especially favored by local circumstances, have been driven to the Middle States, where the tax-rate is lower because the State governments take a less exacting view of their duty to their people.

Taking the country as a whole, however, we find that the direct taxation upon all kinds of property and incomes is higher than in any country of Europe, except one, and an analysis of local tax-lists seems to show that nearly three-fourths of this burden is borne by people whose estates amount to less than \$5000 each, this class constituting ninety-seven per cent. of the taxpayers. The aggregate of property taxes levied by the State and local governments in 1880 was \$312,750,000, being \$6.23 a head of the population, and \$18.50 per \$1000 of its property.

Remedies for the weight of this great burden have been sought in (1) the monopoly of monopolies like the gas-supply and street-railways by municipal governments; (2) and in the heavier taxation of such monopolies as railroad corporations by the States, so as to secure from them some equivalent for the valuable franchises bestowed upon them by the community. But even these are only alleviations of an evil, which must be corrected in a more radical way, either by the transfer of costly government duties like education and police to the national government, or by the transfer of its surplus of revenue from the national government to the States.

The former proposal is that which commends itself to those who wish to see the general government strengthened at the expense of the States, as has been the tendency throughout our history, with few interruptions. The latter should commend itself to those who value the State governments as a counterpoise to the centralizing tendency. As such it was advocated by Mr. Calhoun in 1836, and accepted by the States' Rights party of that day. The difficulty of securing a two-thirds vote in Congress and the vote of three-fourths of the State Legislatures for an amendment to the Constitution makes the former plan very difficult of application. It is safe to say that nothing but the prolonged failure to return to Mr. Calhoun's plan can give it a chance of adoption. It is that which may bring the country to such an urgent sense of the need of a fiscal reconstruction as may force the adoption of the most drastic remedy at hand. At present the proposal to aid the States in educating their illiterate population, and that for refunding the amount of the direct tax levied in 1861 as a war measure by the general government, both indicate a growing disposition to treat the national revenue as not to be isolated from the needs of the State and local governments. (R. E. T.)

TAXIDERMY (derived from the Greek *τάξις*, arrangement, and *δέρμα*, hide or skin) is the art of preserving the outward forms of birds and animals. The stuffing of birds and other animals is of ancient date, but the first to adopt the art as a business were the Verreaux Frères, of Paris, early in the present century. Examples of their work may be seen in the American Museum in Central Park, New York. Before their day each museum was obliged to collect its own specimens and have them stuffed as they could. At the present day many individuals and firms, both in Europe and America, make a special business of the art. The naturalists of former centuries made no

attempt to collect specimens as nearly as possible in a state of nature. Even Audubon paid no attention to taxidermy. When he secured a rare bird he pinned it to a tree and made drawings to reproduce, as nearly as possible, the natural tints of the plumage. After this the skin was removed and dried; but no attempt was made to stuff it so as to resemble the bird while alive. The collection of drawings left by Audubon have always been highly prized; but if, instead of the drawings, the great naturalist had acquired the art of taxidermy, his collection would have been more valuable. The noted English naturalist, Charles Waterton, was the first in his special line of investigation to practise taxidermy. His specimens, now in the American Museum in New York city, are of great value as attempting to show the natural positions of the birds. Waterton left particular directions as to the stuffing of birds. He pointed out that a bird's body is not completely covered by feathers, but has places about the shoulders, under the wings, and on the thighs, where the skin is nearly bare. Unskillful taxidermists stuff these parts to a fuller extent than in nature, with the result of destroying the original proportions. He also pointed out that, in mounting, the legs were usually too much lengthened, and advised that the three bones of the legs should be fixed to form the letter Z, because the upper joint of the thigh is never straight.

In the practical work of taxidermy, the skin of a bird demands the most careful attention from the moment it is killed. Cotton should be used to fill the wounds, and a damp sponge to wipe blood from the feathers. In cold weather the bird may be allowed to become cold before skinning; but in hot weather it must be skinned at once. The operation is this: beginning at the breast-bone, the skin is slowly separated by forcing a blunt instrument between it and the flesh; the bones of the wings are cut at the shoulder-joints, and when getting the skin from the skull the vertebrae can be unjointed; then remove the brains and eyes; the flesh is taken from under the bill, using care not to mutilate the openings of the ears or eye-lids; the skin should then be rubbed with a solution of arsenic or corrosive sublimate and prepared for drying.

Dr. Jared P. Kirtland, of Ohio, one of the best taxidermists in the United States, but more especially in the West, gave the following instructions to young taxidermists. The implements needed are: a glover's three-cornered needle, a knitting-needle sharpened and fixed in a handle, and a sharp knife. Arsenical soap is to be prepared as follows: pulverized arsenic, 2 lbs.; potash in powder, 12 oz.; camphor gum, 5 oz.; white soap, 2 lbs.; lime in powder, 4 oz. Shave the soap into small pieces, place it in a pipkin over a slow fire and add a little water; stir with a wooden spatula till the soap is dissolved; take it off and add potash, and stir well; add the lime by small quantities and then the arsenic, stirring till all are thoroughly mixed; when nearly cold add the camphor, dissolved in strong alcohol; if the mixture becomes too thick, add water sufficient to reduce. Dr. Kirtland advised that the bird be allowed to lie from 2 to 4 hours before skinning, without regard to the temperature of the day. In handling the damp skin care should be taken not to squeeze the head. The throat should be swabbed with cotton and filled with powdered plaster of Paris. Cotton should also be crowded into the mouth, and plaster into all the cavities of the head. The cotton and plaster prevent fluids from issuing out of the head and spoiling the skin. Having smoothed the feathers carefully with cotton, lay the bird upon a piece of thick pasteboard or a thin board covered with cotton-flannel, soft side up. Place the bird upon this with the head toward the left hand. Separate the legs and feathers and at the end of the breast-bone begin to cut through the skin, downwards. If blood or other fluids issue, put in plaster of Paris to absorb them. Do the left side in the same manner, cutting the muscles and the flesh from the body. Cut the muscles of the wings. The

membrane of the ear must be undermined by a knife and the knife forced upwards, bringing out the ends nearest the bill. Remove the eyes. Clear away the brain, tongue, and muscles. Wash the inside of the skull with arsenical soap and fill the skull full of powdered arsenic. Then press a piece of cotton into the sockets. Leave the bones of the wing and cut the muscles. Insert a thread at the other end of the bone in the skin; break the knob off at the end of the wing-bone. Take the muscles out of the legs and sometimes take the fat off the legs. Lubricate with arsenical soap and wind the bone with cotton. Then tie the wings with threads, not too tightly. Lubricate the whole with arsenical soap. Get the ball of cotton out of the nostrils. Run a little awl, of the size of a small wire, behind the toes to the joint; then straighten the legs and tie the bone to the wire. Take the cotton off and put more on with arsenical soap. Prepare a cork body of the length of the bird and as large round as a large-sized bottle-cork. Join the two wires which are already in the legs, and another for the neck to the cork body, leaving them to project 3 or 4 ins. outside the real body. Wind cotton upon the wire till it becomes as large as the neck, and lubricate with arsenical soap. Wind cotton around an instrument like a knitting-needle till it is about the size of the little finger and take them off—as fast as made—and lay them on, under, and around the cork body. Press it from time to time and put in arsenic powder. Insert the leg wires; do not place the legs too far back or make the breast too full. Use arsenic freely. Begin at the upper part to sew. Put a little *aqua ammoniac* in the eye-sockets and let it remain for an hour. Then clear away unnecessary matter and put putty in the cavities. Lubed a glass eye in the putty, taking care not to let the putty show. (F. G. M.)

TAYLOR, GEORGE (1716-1781), a signer of the Declaration of Independence, was born in Ireland, and emigrated to Pennsylvania as a "redemptioner" in 1736. From being a laborer in an iron-foundry he rose to be a proprietor in Northumberland co., and in 1764 was elected to the colonial assembly. After 5 years' service he was made county judge, and in 1775 was again a member of the assembly. Here he took the patriotic side, and on July 20, 1776, was one of the new members chosen as delegates to Congress. As such he was allowed to affix his signature to the famous Declaration on Aug. 2. He was afterwards employed in negotiating treaties with Indian tribes. His service in Congress was brief, and he died at Easton, Pa., Feb. 23, 1781.

TAYLOR, NATHANIEL WILLIAM (1786-1858), theologian, was born at New Milford, Conn., June 23, 1786. He graduated at Yale College in 1807, studied theology, and in 1812 was ordained pastor of the First Congregational Church of New Haven. In 1823 he was made Dwight professor of didactic theology in the seminary then established in connection with Yale College. During his 36 years of service in this position about 700 students received his instruction. His essays and sermons attracted marked attention. He carried further Dwight and Edwards' modification of Calvinistic theology, and in his *Works* insisted that man, though by nature indisposed to holiness, was yet not without ability to repent. This view he maintained not only in his lectures on the "Moral Government of God," but also in the *Christian Spectator*, which he edited for twenty years. In it he also vigorously opposed Unitarianism. He died March 10, 1858. Rev. Dr. Noah Porter, his son-in-law, edited his *Works* (5 vols., 1858-62).

TAYLOR, WILLIAM MACKERGO, minister, was born at Kilmarnock, Scotland, Oct. 23, 1829. He graduated at the University of Glasgow in 1849 and studied theology at Edinburgh. He was ordained pastor of a United Presbyterian church at Kilmarnock, Scotland, in 1853, and in 1855 accepted a call to a church in Liverpool. In 1872 he became pastor of

the Broadway Tabernacle Church, New York. He has twice delivered courses of lecture on "Preaching" in Yale Seminary and another course on "Gospel Miracles" at Princeton. From 1876 to 1880 he was editor of the *Christian at Work*. Many volumes of his sermons have been published, among them being *The Lost Found* (1870); *David, King of Israel* (1875); *Elijah the Prophet* (1876); *Songs in the Night* (1877); *Peter the Apostle* (1877); *Daniel the Beloved* (1878); *Moses the Lawgiver* (1879); *Paul the Missionary* (1882); *Joseph the Prime Minister* (1886). He has also published a biography of *John Knox* (1885).

TECUMSEH (1770-1813), noted Indian chief, was born near the site of Springfield, Ohio, about 1770. In youth he was of a mild disposition, yet was always averse to the whites. In his first fight with them, when 20 years old, he is said to have run away, yet he afterwards had a reputation for dauntless courage. In 1804, with his brother, Elskwatawa, known as the "Prophet," he formed a scheme for uniting the Indian tribes and extirpating the whites. They visited the tribes on the great lakes and the Mississippi, professing to deliver a message from the Great Spirit. At their camp, near Greenville, some hundreds of warriors were gathered, and in 1810 Gov. W. H. Harrison was notified that the further appropriation of lands by the whites would be resisted. In the autumn of 1811 Tecumseh, in furtherance of their project, went to visit the Creeks and Cherokees in Alabama and Georgia. During his absence Harrison, with a force of 900 men, marched to Tippecanoe and encamped there. The Prophet directed an assault to be made early on Nov. 7, but the Indians were repulsed and fled. Tecumseh in the next year went to Canada, then threatened with invasion by Gen. Hull's army. With 700 men he joined the British forces, fought at the River Malden, and was present at Hull's surrender at Detroit. He was commissioned brigadier-general with command of all the Indians fighting for the king. During the contest in the next year he appears to have lost heart in the British cause, and before the battle of the Thames, Oct. 5, 1813, he is said to have predicted his own death. He had command of the right wing, which was routed by Col. R. M. Johnson, who is said by some to have shot Tecumseh. His brother, the Prophet, a man of low cunning and altogether inferior character, lived to obtain a pension from the British, but lost his reputation, and died in 1834. See the *Life of Tecumseh* (1878) by E. Eggleston and L. E. Seeley.

TEETH. See DENTISTRY.

TELEGRAPHY. This article is confined to the history of the telegraph in the United States. About the year 1827 Prof. Joseph Henry (afterwards secretary of the Smithsonian Institution) began a series of experiments in the attic of the Boys' Academy building in Albany, N. Y., among which was included the running of a wire about the room, and the sending of signals from one end to the other by means of an electric current. During the summer of 1832 Prof. S. F. B. Morse (for whom see ENCYCLOPEDIA BRITANICA) conceived the idea of an electric or electro-magnetic telegraph; and, after numerous experiments, announced his invention to the public in April, 1837. Hon. Levi Woodbury, secretary of the U. S. Treasury, on March 10, 1837, issued a circular requesting information in regard to establishing a system of telegraphs for the United States, to which Prof. Morse replied, giving an account of his invention, its proposed advantages and probable expense. At that time he "presumed 5 words could be transmitted in a minute." Morse petitioned Congress for aid to enable him to test the practical operation of his invention, and an appropriation of \$30,000 was made for this purpose. In 1843 he began to erect the first telegraphic line between Washington and Baltimore, a length of 40 miles. It was at first proposed to lay the wires in leaden pipes along the line of the Baltimore and Ohio

Railroad, but this plan was abandoned, and the wires were suspended on poles, a metallic circuit being formed. The wire had reached Annapolis Junction just before the National Whig convention opened in Baltimore in May, 1844. A friendly Congressman suggested to Prof. Morse that the opportunity had now come for him to show what could be done. A man at Annapolis Junction was directed to get information of what the convention had done as soon as the afternoon train arrived there from Baltimore, and telegraph it at once to Washington. The capital was in a ferment, every citizen being anxious for the news from Baltimore, which should be brought by railroad. Prof. Morse and his friend spent that afternoon in his machine-shop. The wire was operating well, and soon Morse was able to announce, "The convention has adjourned. The train for Washington has just left, and the ticket is Clay and Frelinghuysen." In spite of some doubts the news was quickly spread in Washington before the train bearing the delegates from the convention could reach that city. This fact should have settled the question that Morse's invention was of practical use. And yet almost a year passed before the Washington office could be opened for regular business. The earnings of its first week, in April, 1845, were only \$3,094.

The telegraph line from Washington was but slowly extended to Philadelphia and New York, a distance of 250 miles. It reached Boston in 1845, and became the great line of the North, from which branched two others, one from Philadelphia to Pittsburg, Cincinnati, and St. Louis, 1000 miles; the other from New York to Albany, Buffalo, Cleveland, Chicago, and Milwaukee, 1300 miles. Another line, 1395 miles in length, connected Buffalo, Niagara, Toronto, Montreal, Quebec, and Halifax. Two lines ran south to New Orleans, one from New York, Washington, and Charleston, 1966 miles; the other from Cleveland and Cincinnati, via Nashville, 1200 miles. The only line constructed with government aid was the original one connecting the cities of Washington and Baltimore. The others were established by private enterprise. The following table exhibits the annual receipts of the "Magnetic Telegraph Company," extending from Washington to New York, which was the first organized in this country: From Jan. 27, 1846, to July 1, 1846, \$4228.77; to July 1, 1847, \$32,810.28; to July 1, 1848, \$52,252.81; to July 1, 1849, \$63,367.62; to July 1, 1850, \$61,383.98; to July 1, 1851, \$67,737.12; to July 1, 1852, \$103,860.84; total amount received up to July, 1852, \$385,641.42. In 1852 the telegraphic charges from Washington to various cities were as follows: Baltimore, 20 cents; Boston, 75 cents; Buffalo, 90 cents; Chicago, \$1.25; Cincinnati, 70 cents; Louisville, 95 cents; Milwaukee, \$1.35; Nashville, \$1.35; New Orleans, \$2.20; New York, 50 cents; Philadelphia, 30 cents; Pittsburg, 45 cents; Portland, Me., 95 cents; St. Louis, \$1.20.

A report made for the U. S. census of 1850 stated: "The amount of business which a well-conducted office can perform is immense. Nearly 700 messages, exclusive of those for the press, were sent in one day over the Morse Albany line; and a few days after the Bain line at Boston sent and received 500 communications. Another office, with two wires, after spending three hours in the transmission of public news, telegraphed in a single day 450 private messages, averaging 25 words each, besides the address, 60 of which were sent in succession without a word of repetition. Messages passing from one very distant point to another have usually to be rewritten at intermediate stations; though, by an improved method, the Seaboard line has, in good weather, transmitted communications direct between New York and Mobile, a distance of nearly 1800 miles without intermediate rewriting. By the Cincinnati route to New Orleans, a distance of nearly 2000 miles, the news brought by an Atlantic steamer at 8 A. M. has been telegraphed from New

York to that distant point, and the effects produced in the market there returned to New York by 11 A. M. The Congressional reports from Washington are usually received simultaneously in Baltimore, Philadelphia, and New York; and all that is necessary at the intermediate stations is for an operator to be present and receive the message as it is developed on paper by the instruments.

"The electric telegraph has been applied in this country to a new and highly important purpose—that of the registration of astronomical observations; thus establishing the best possible means for the determination of the difference of longitude. The observatories in different parts of the country are connected by telegraphic wires; and the most delicate experiments, dependent upon the appreciation of minute portions of time, have been successfully performed. This method has been recently used for the determination of the wave time of electrical currents.

"The great extent of the telegraphic business and its importance to the community is shown by a statement of the amount paid for despatches by the Associated Press of New York, composed of the seven principal morning papers—the *Courier and Enquirer*, *Tribune*, *Herald*, *Journal of Commerce*, *Sun*, *Times*, and *Express*. During the year ending Nov. 1, 1852, these papers paid nearly \$15,000 for despatches, and about \$14,000 for special and exclusive messages not included in the expense of the association."

The original invention of Prof. Morse was what is known as the "single circuit." Soon afterward a needle system was invented containing two multipliers, and using an alphabet wherein the signals were dashes at angles instead of the Morse arrangement in parallel lines.

Alexander Bain, (*q. v.*) a native of Scotland, patented an electro-chemical telegraph on Dec. 12, 1846; and another patent was granted to him in connection with Robert Smith, in October, 1849. The advantages which the inventor attributed to the electro-chemical telegraph were: "1st. More economy and simplicity in the primitive construction; 2d. More rapidity in the transmission of despatches. A single wire, with a good insulator, can transmit 1200 letters a minute; 3d. An electric current, more feeble than ordinary, suffices to cause the apparatus to work; 4th. More simplicity and economy in the correspondence and superintendence; 5th. Fewer chances of error in the despatches sent." The Bain telegraph was materially improved by Henry J. Rogers. The earlier Bain telegraph lines ran from New York to Boston, from Boston to Burlington and Ogdensburgh, from Boston to Portland, from Troy to Saratoga, and from New York to Buffalo.

The "House printing telegraph" was invented by Royal E. House, a Pennsylvanian, and patented April 18, 1846. The first line operating with this instrument was completed in August, 1850, by the Boston and New York Telegraph Company between those cities. It was patented in England by Jacob Brett. The difference between Morse's and House's telegraph was, principally, that the former traced at the distant end what was marked at the other; while House's did not trace at either end, but made a signal of a letter at the distant end which had been made at the other, and thus, by new machinery and a new power of air and axial magnetism, was enabled to print the signal letter at the last end at the rate of sixty or seventy strokes, or breaks, in a second, and at once recorded the information, by its own machinery, in printed letters. Morse's was less complicated and more easily understood, while House's was very difficult to be comprehended in its operations in detail, and worked with the addition of two more powers, one air and the other called axial magnetism. One was a tracing or writing telegraph; the other, a signal and printing telegraph. The earlier House lines were from Boston to New York, from Boston to Spring-

field, Albany, and New York, from Poughkeepsie to Troy, Albany, and Buffalo, and from Philadelphia to New York. In 1848 the House Printing Telegraph Company entered into competition with the Bain and a similar company. In 1849 the owners of the Morse patent sued the Bain operators, and a compromise was concluded by which the Morse patents were used over the wires of both companies. The Bain wires, however, were used between Boston and Montreal for many years. The House printing machine was in use until 1847. It was similar to the ticker of to-day, but larger; the operator turned a crank with his foot to induce the proper current. The House machine was much more rapid and could do more work than the Morse instrument, but in wet weather it became useless on account of the escape, and the wire had to be thrown upon the Morse apparatus. The House circuit was the best and the largest wire, being No. 6 gauge of plain iron. The insulators were made of a large iron cap which went on top of the pole. The wire rested in a cleat made of iron but insulated from the main cap, which was considered the best insulation at that time. In 1855 the Hughes printing machine was patented; but it was such a delicate instrument, with its vibrating spring, that it did not meet with much favor.

In 1855 the rival lines in the West had all been consolidated into one company, which was named the Ohio and Mississippi Printing Telegraph Company. The word "printing" was added on account of the company's using the House instrument. This company was incorporated in 1851 by the State of New York, with a capital of \$360,000, of which about \$75,000 was paid. At that time this company was only one of some twenty or thirty that were struggling for existence in the country, most of them situated in the Western States. Each company had a separate set of officers and employes of all grades; and instead of making money for its shareholders it was heavily mortgaged and working at a loss. The stocks of these companies were almost valueless, and the investors in the new company determined to buy them up and consolidate the management. By an act of the New York Legislature, April, 1856, it had its name changed to the Western Union Telegraph Company. The Legislature of Wisconsin also issued articles of incorporation of the company in 1856, when its capital was placed at \$500,000 with the privilege of increasing it to \$1,000,000. The company then turned its attention to the purchase and leasing of lines of struggling Western companies. It soon acquired control of all the wires west of Buffalo and Pittsburg. The wires east of those points were under the management of the American Telegraph Company, of New York, with Amos Kendall, president, though the Western Union built a new line from Philadelphia to Pittsburg.

In 1859 the telegraph line from Omaha to Salt Lake City to meet the California State Telegraph Company was projected and J. H. Wade, of Cleveland; Edward M. Creighton, of Omaha; J. M. Stebbins, of St. Louis; Hiram Sibley, of Rochester, N. Y., and others were the prime movers in this enterprise. The Indians interfered in every way possible by killing the line-men and cutting down the poles and wire after the gangs and troops had passed on. Down to 1860 the intervention of the government had been confined to the passage of a few acts granting aid and protection to parties proposing to extend the telegraph to the Pacific coast and to the Atlantic Cable Company. In June of that year Congress offered a bonus of \$40,000 a year for 10 years, in addition to rights on the public lands, to parties who would undertake the construction of a line from the Missouri to the Pacific; and the line was completed in 1861. The wire was seldom working more than two or three days at a time; after an interval of the same length the company would succeed in getting it to work for as many days more. But business was accepted at gold

rates and held at Omaha, because the time, even at this slow rate, was much shorter than the water route, via Panama. When the Indians ceased their opposition, the Overland Telegraph Company became a very fortunate venture.

At the beginning of the civil war the telegraphic territory of the country, was divided mainly between the American Company running through the eastern slope from Nova Scotia to New Orleans; the Southwestern, extending from New Orleans through Mississippi, Tennessee, and Kentucky to Louisville, and the Western Union Company, extending through the Middle and Western States. The California State Telegraph Company operated the lines on the Pacific slope connected with the Western Union by the line above mentioned; the Illinois and Mississippi Company operated lines west of Chicago; the Northwestern Company, those through Wisconsin and Minnesota, which maintained an independent organization until their absorption in 1884. These lines all worked in connection as one system, although under different managements. The capital stock of the Western Union Company was \$3,000,000, representing the \$2,000,000, to which it had been quadrupled, and accretions from various sources. In 1861 a stock dividend of \$3,000,000 was added. In 1863 and 1864 \$5,000,000 more was issued to represent extensions and new lines; and, in the latter year, the stock was doubled by an issue of \$11,000,000 as a dividend. In 1863 and 1864 the Russian extension was organized with a capital of \$10,000,000. During and after the civil war an active opposition arose from the United States Telegraph Company, competing in the territory of the Western Union over some 14,000 miles of wire. In 1866 commenced a plan of consolidation; the 14,000 miles of the United States Telegraph Company's wires were purchased with new stock of the Western Union valued at \$6,315,800. The Illinois and Mississippi and the Southwestern Companies' lines were absorbed. Bonds to the amount of \$1,652,000 were issued for the California Telegraph lines, and for each share of the American Company's stock three shares were issued. When this consolidation was accomplished, the Western Union Company stood without an important rival in the telegraph business of the country, with a capital stock of \$41,000,000 and a total nominal investment of \$17,877,350.

The year 1866 thus marked an important epoch in the history of the telegraph system in this country. From that time the stock of the Western Union Company was increased from \$41,000,000 to \$80,000,000 in 1884. In that year the National Telegraph lines were sold to the Baltimore and Ohio Telegraph Company, and the latter became a great rival of the Western Union. The National Telegraph Company was the result of a consolidation between the two telegraph lines running from Buffalo to Chicago along the "Nickel-Plate" Railroad, and from New York city to Buffalo along the West Shore Railroad. This made a continuous line from New York to Chicago. The consolidation extended the line of the Baltimore and Ohio from New York city to the principal cities east of the Mis-

issippi. The Baltimore and Ohio Telegraph, as a distinct organization, dated from Jan. 1, 1882, although the telegraph lines of the railroad were in operation many years before. During the civil war the railroad, in connection with the American Telegraph Company, made additions to its telegraph lines in order to transmit commercial messages. When the consolidation of the Western Union and the American lines took place the Baltimore and Ohio refused to surrender the independence of its telegraph system. On Jan. 1, 1877, the Baltimore and Ohio Telegraph broke away from the Western Union and gave assistance to the Atlantic and Pacific Telegraph Company. When, in the fall of 1877, the Western Union absorbed that company the Baltimore and Ohio sought other telegraph connections, which were secured in May, 1879, through the American Union Company. When the consolidation of the latter with the Western Union took place, in 1881, the Baltimore and Ohio determined to establish its telegraph system on a thoroughly independent basis, and the Baltimore and Ohio Telegraph Company was formed, and it soon determined to extend its lines to all important points east of the Rocky Mountains. But in 1887 the Western Union gained complete control of the Baltimore and Ohio Company, and since that time it has had practically no opposition. The special gain by the transfer was the acquiring of many miles of wires that ran along railroads, but had been used hitherto chiefly to help the service of such roads. In October, 1888, the Western Union Telegraph Company reported its outstanding capital stock at \$86,199,852.06, of which \$25,976,700 belongs to the company. The stock was increased during the year by the purchase of the Baltimore and Ohio Telegraph Company, for which purpose \$5,000,000 of additional stock was issued. The bonded debt, less balance in the sinking fund, was \$6,737,038.32. The gross revenues for the year ending June 30, 1888, were \$19,711,164.12, and the expenses were \$14,640,592.18, leaving a profit of \$5,070,571.94. The surplus amounts to \$7,498,548.94. In addition to the Baltimore and Ohio system, consisting of 6711 miles of line, carrying 54,087 miles of wire, and the New York and Southern system, consisting of 1528 miles of line, and carrying 5090 miles of wire, acquired during the year, the company constructed 6322 miles of new line, carrying 32,430 miles of wire, on which account there was appropriated \$1,219,590.67. The total additions to the plant were 14,561 miles of line, and 91,607 miles of wire, and 1583 additional and newly equipped offices. The average amount received per message during the year was 31.2 cents as against 30.4 cents the year before. At the close of 1888 the company owned and operated 171,375 miles of poles and cables, carrying 616,248 miles of wire, over which there were sent during the year 51,463,955 messages from 17,241 offices. In the 22 years of its existence the company earned and collected \$91,383,726.83, and paid in dividends \$51,185,565.07. The following table shows the growth of the Western Union Telegraph Company in various years since 1866:

Statistics of the Western Union Telegraph Company.

Year.	Miles of line.	Miles of wire.	Offices.	Messages sent.	Receipts.	Expenses.	Profits.	Average tolls per message. cts.	Average cost per message. cts.	Average profit per message. cts.
1866	37,380	75,686	2,250		\$6,568,925	\$3,944,006	\$2,624,920			
1870	54,109	112,191	3,972	9,157,646	7,637,449	5,104,787	2,532,662	69.5	45.7	23.8
1875	72,833	179,196	6,565	17,153,710	10,034,986	6,635,474	3,399,510	50.9	33.5	17.4
1880	85,615	233,534	9,977	29,216,509	12,782,895	6,948,957	5,833,938	43.7	23.7	19.3
1885	117,500	462,283	14,184	42,096,583	17,706,854	12,005,909	5,700,924	32.1	24.9	7.2
1886	151,832	489,607	15,142	43,289,807	16,298,638	12,378,783	3,999,855	37.6	28.5	9.1
1887	256,814	524,641	15,658	47,394,530	17,191,910	13,154,029	4,037,281	30.4	27.7	8.5
1888	171,375	616,248	17,241	51,463,955	19,711,164	14,640,592	5,070,571	31.2		

The fact that the Western Union Company had secured virtual control of the telegraph business in this country led to attempts in Congress from 1882 to 1885 for the establishment of a postal telegraph to be carried on by the U. S. government. (See *POSTAL SERVICE*.)

What is called quadruplex telegraph (or the transmission of 4 messages from a single wire at the same time) has been made possible by a combination of single and double currents. In the duplex working one operator sends upon a key which reverses and operates only on the sending battery, whilst the working of another key brings into play the full strength of the battery. At the receiving end one man reads his messages from a delicately adjusted instrument, which is acted upon only by the reverse currents of the first sending operator, while another receives his message from a less delicate machine, responding only to the stronger signals sent by the second sending clerk. To accomplish quadruplex working an arrangement is made, permitting transmissions in opposite directions at the same time. This is done by making the receiving apparatus of the home station insensible to the effects of the outgoing currents.

Later improvements of transmission include an invention which can send some hundreds of words per minute, and have them received at the receiving station in Roman letters, all ready for the attendant to place in envelopes and send to the persons addressed. Experiments are still making in regard to the laying of wires underground, and several miles of subways have already been laid in the city of New York with moderate success. The same experiments are extending to Washington, Boston, and other cities.

The aggregate mileage of telegraph lines in the United States used for public business exceeds 180,000; which is exclusive of railroad, government, private, and telephone lines, the length of which cannot be ascertained.

Submarine Telegraphs.—In June, 1852, the submarine telegraph between Dover and Ostend was completed, and on Nov. 1 electric communication was established direct between Great Britain and the continent of Europe. The history of the Atlantic cable is full of interest. Cyrus W. Field, of New York city, was applied to in 1854 for aid in completing a land telegraphic line which had been begun in Newfoundland, to cross the island, 400 miles, from Cape Ray to St. John's, from which it was intended to run a line of fast steamers to the west coast of Ireland, and thus bring America within a week of Europe. While studying this subject, and turning over the globe in his library, he thought, "Why not carry the line across the ocean?" Going to St. John's, Newfoundland, in March, 1854, he obtained from the Legislature of that colony a charter granting an exclusive right for 50 years to establish a telegraph from the continent of America to Newfoundland and thence to Europe. On March 10, 1854, the articles of association were signed by five citizens of New York—Peter Cooper, Moses Taylor, Marshall O. Roberts, Chandler White, and Cyrus W. Field. Mr. Cooper became president of the association. Mr. White subsequently died, and Wilson G. Hunt took his place. The association was called "The New York, Newfoundland, and London Telegraph Company." More than two years were required to build the land line across Newfoundland and Cape Breton Island. Meantime Mr. Field went to Europe and ordered a submarine cable, to connect Cape Ray and Cape Breton. This was sent out in 1855, and was lost in a gale in an attempt to lay it across the Gulf of St. Lawrence, but the attempt was successfully renewed in 1856. In that year Mr. Field again went to London and organized the Atlantic Telegraph Company, to carry the line across the ocean. As an evidence of his confidence in its success, Mr. Field subscribed a fourth of the entire capital stock of the company. He secured from the British and American governments aid

in ships, and he accompanied the expeditions which sailed from England in 1857 and 1858 for the purpose of laying the cable across the Atlantic Ocean. Twice the attempt failed in 1857, and again in 1858. The third attempt proved successful, and in 1858 telegraphic communication was established between England and America. The first public messages were congratulations between Queen Victoria and Pres. Buchanan, which occupied in transmission 67 minutes each. Doubts were expressed of the genuineness of these despatches, and only when a despatch conveying the action of Parliament on an important public matter was verified by mail two weeks afterward were these despatches accepted as real. But in a few weeks the cable ceased to work, and it was again pronounced a failure. Mr. Field, however, never lost faith in its ultimate success, and he made frequent trips to Europe to resuscitate the company. But the American civil war broke out, and not until 1865 was another expedition prepared.

Meantime submarine telegraphy had been greatly improved in many ways, a better cable was prepared, and the steamship *Great Eastern* took it on board and sailed for the American coast. Over 1200 miles of cable had been laid, when, by a sudden lurch of the vessel, the cable snapped and was lost. The bottom of the sea was dragged for days in search of the broken end, and the expedition returned to England. In 1866 the *Great Eastern* again sailed with a fresh cable, and 2000 miles of wire were safely stretched across the ocean, and the communication was perfected July 27, 1866. After landing this the *Great Eastern* returned to the middle of the ocean, and after two months' search succeeded in grappling the sunken cable of the year previous. It was brought up from a depth of two miles, joined to the cable on the steamship, and carried safely to the western shore. After twelve years of incessant labor, in which he crossed the ocean nearly fifty times, Mr. Field saw the crowning effort of his life accomplished. Congress voted him a gold medal with the thanks of the nation, while the prime minister of England declared that it was only the fact that he was a citizen of another country that prevented his receiving high honors from the British government. The first cable cost \$1,256,250, and the company's expenditures up to Dec. 1, 1858, amounted to \$1,834,500. Among the despatches sent over the new cable was the speech of the King of Prussia just before the Austrian war of 1866. It cost \$3000 to transmit it. This cable has been in running order almost continually since its successful completion.

In 1874 work was begun by the "Direct Cable Company" to lay a cable between Ballinskellings Bay, in the southern part of Ireland, and Rye, New Hampshire, by way of Nova Scotia. It was finally completed in 1875. The Commercial Company laid a series of duplicate cables in 1884. The starting point may be considered the village of Waterville, near Ballinskellings Point, but a few miles south of Valentia, the terminus of the earliest ocean lines. From this point the new line has double connections to the English and European centres; a land line direct to Liverpool, London, and Paris; also a submarine cable through the English Channel to Havre, thence two separate cables across the Atlantic to Canso, from which place it has two submarine cables to the United States, one to Rockport and another direct from Canso to New York city, thus giving double lines from London and Paris to Boston and New York. These lines are all duplicated for two reasons, the press of business and the contingency of disaster to one of them. The system adopted is known as octoplex harmonic, one wire doing the duty of eight. The cost of these cables is estimated to have been about \$10,000,000.

Method of Working.—In the early part of the history of the Atlantic cable, the flash system of signals was used; the messages were spelled out by flashing rays of light back and forth across a standard line, the right

and left flashes corresponding with the dots and dashes of the ordinary telegraph alphabet. In Stern's system, which is now used by the French cable, having its terminus at North Eastham, Mass., the light is flashed by reflection from an extremely light mirror, which is turned to right and left by the opposing influence of positive and negative impulses. This system has the advantage of being operated with very slight impulses, but also the disadvantage of leaving no permanent record. To secure the latter very important end, the recording instrument has been adopted. The recorder is a horseshoe magnet, electrified by the usual circle of fine wire, and attracting a small metallic coil. The coil is hung between the magnet-poles; and by a light lever and a thread almost as fine as the strand of a cobweb it is connected with a delicate siphon hung in a little reservoir of ink. The ink is electrified, so as to produce a repulsion of the particles, making it flow more readily through the siphon, which outside is about the size of a darning-needle, and the interior tube scarcely larger than a hair. The lower end of the siphon rests against a paper tape playing perpendicularly through rollers. The whole machine is almost of gossamer fineness and flexibility, so as to minimize the electric strain necessary for working the cable. The Commercial (or Mackay-Bennett) Company has adopted the system known as the William Thomson siphon recorder. Between the two poles of a powerful magnet is suspended a piece of soft iron. In this the magnetism is concentrated. In the field is suspended a coil of fine wire. The motion of the coil is transmitted to the siphon—fed with the purest aniline ink—by means of a silk fibre so fine as to be almost invisible. A revolving electric motor feeds the ink generator by induction between its armatures and two enveloping shields, and that induces the current. The instrument used in Wall street, New York, is very small and the work noiseless. An endless tape passes under the point of the siphon, which moves back and forth at the rate of 100 dots a second. The tape can be read at any time, and the messages preserved; but this could not be done by the old system of mirrors.

It has been proposed to establish telegraphic communication between Australia, New Zealand, Canada, and Great Britain, by means of a line perfectly independent of existing lines and freed from foreign influences. This would require a chain of cables across the Pacific Ocean from Brisbane or Sidney to the north of New Zealand, thence via the Fiji Islands, the Fanning Islands, the Sandwich Islands to Vancouver Island, then across to the new city of Vancouver on the mainland, the terminus of the Canadian Pacific Railway. The line would follow this railway and be extended possibly to Gaspé, in the Province of Quebec. From Gaspé a new cable would be laid through the Straits of Belle Isle to the United Kingdom, unless it was found to be practicable to secure control of the existing lines across the Atlantic. The total length of cables contemplated in the Pacific and Atlantic Oceans is 11,145 miles, and the distance across the continent will be 3450 miles, making in all about 15,000 miles.

Since the opening of the first Atlantic cable the rates charged for the messages have been steadily reduced, as is shown by the following: In 1866, \$100 were charged for 20 words or less; from November, 1867, \$50 for 20 words or less; from December, 1867, \$25 for 10 words or less; from September, 1868, \$16.85 for 10 words or less; from June, 1869, \$10 for 10 words or less; from August, 1869, \$7.50 for 10 words or less; from December, 1870, \$15 for 10 words or less; from July, 1871, \$10 for 10 words or less; from May, 1872, \$1 per word; from May, 1875, 50 cents per word; from December, 1884, 40 cents per word. (F. G. M.)

TELESCOPES, AMERICAN. The earliest manufacturer of astronomical telescopes in the United States of whom we have record was Amasa Holcomb, of Southwick, Mass. He made his first experiments in grinding lenses in 1826, and completed in 1830 an

achromatic objective of about 48 inches focal length. See Vol. XXIII, p. 135 (p. 135 Am. Rep.).

Owing, however, to the difficulty of obtaining suitable glass for objectives, he turned his attention to the manufacture of reflecting telescopes, and achieved considerable success in this direction. His reflectors were from 4 to 10 inches in diameter, mounted in the Herschelian form; that is, with the mirror inclined slightly to the axis of the telescope, so that the image is formed near the upper edge of the tube, and is there magnified and examined. In 1838 Mason, Smith, and Bradley, the two first, at that time, students in Yale College, built a reflector of 12 inches aperture, with which some very creditable work upon nebule was accomplished.

Thirty years ago the most prominent telescope-maker in the United States was Mr. Henry Fitz, of New York. His largest objectives are given in the table below. Spence, of Canastota, N. Y., made in 1856 the 13½-in. refractor of the Litchfield Observatory of Hamilton College, with which Dr. Peters has discovered no less than 47 asteroids, and Davis, of Cincinnati, an 11-in. objective which is now mounted at Smith College, Northampton, Mass. Many small objectives, some of a very high order of excellence, have been produced by American opticians—Stendieck, Kahler, Gregg, Allen, Walther, Byrne, Clacey, and Tolles, the three last-named making especial efforts to grind lenses of short focus. Clacey's largest glass, of 10¼ in. aperture and 9 ft. 9 in. focal length, has recently been completed for the Smith Observatory, Geneva, N. Y. The ratio of aperture to focal length is here 1 to 12, while the usually accepted ratio is about 1 to 15.

Reflecting telescopes have thus far met with comparatively little favor in this country. The only one of large size (28 in.) was made by Dr. Henry Draper in 1866-70, and used by him at his observatory at Hastings-on-the-Hudson in researches in spectrum photography. This instrument was removed in 1887 to Harvard College Observatory, where it is now used for similar work under the direction of Prof. Pickering. Brooks, formerly of Phelps, N. Y., has made two reflectors, of 9 and 11 in. respectively, with which he has been remarkably successful in searching for comets, discovering 13 comets within 6 years. Brashear, of Allegheny, has made a number of very excellent reflectors with silvered-glass mirrors, ranging from 5 to 15 in. in diameter. He has also constructed several small refractors, and is now at work upon a 16-in. objective with "photographic correcting lens" for Carlton College Observatory. Dr. C. S. Hastings has figured several excellent objectives upon theoretical curves; his largest, of 9.4 in. aperture and remarkably perfect, is mounted at the Johns-Hopkins University.

Alvan Clark (*q. v.*), who has become famous as an optician the world over, began his career as a telescope-maker in 1846. In 1860 he finished a telescope of 18½ in. aperture, then the largest refractor known. In testing it Mr. Alvan G. Clark discovered the companion of Sirius, the existence of which had long been indicated by theory, though it had hitherto escaped detection. This first of the great Clark refractors was originally intended for the University of Mississippi, but, being prevented by the civil war from reaching its destination, it was purchased by the Chicago Astronomical Society and mounted at the Dearborn Observatory. In 1873 the Clark completed a 26-in. refractor for the U. S. Naval Observatory at Washington, the contract price for which was \$46,000; and, at the same time, they made for Mr. Leander McCormick an objective of a slightly larger aperture, which they mounted in 1883 at the University of Virginia. With the former instrument Prof. A. Hall discovered in 1877 the two small satellites of Mars. In 1879 the Clarks entered into a contract with the Russian government to furnish an objective of 30 in., and in 1880

with the Lick trustees for one of 36 in. The glass for all these large lenses is of foreign manufacture, coming from either Chance & Co. of Birmingham, or Feil & Co., of Paris; and considerable difficulty was experienced in obtaining disks of the requisite degree of purity, particularly in the case of the 36-in. crown glass disk, which involved nearly three years' labor and 19 failures before a suitable piece was obtained. Of smaller objectives the Clarks have made a great number—over 60, probably, between the apertures 6 and 12 in.

The mounting for the 30-in. Pulkowa objective was made by the Repsolds, of Hamburg; that for the Lick glass by Warner & Swasey, of Cleveland, Ohio. The following details of the Lick mounting are taken in part from an illustrated description of the instrument given in *Engineering* for Aug. 17, 1888:

The telescope is supported on a hollow cast-iron column of rectangular section, measuring 4 ft. by 8 ft. at the top, 5 ft. by 9 ft. at the floor line; then spreading rapidly to a base 10 ft. by 16 ft. bearing on the foundation. Around the top is a balcony, to which access is given by a spiral staircase. The objective in its cell weighs about $\frac{1}{2}$ ton, the column and head which carries the polar axis weigh together 21 tons, while the total weight of the telescope complete is 40 tons. The polar axis is of steel, 10 ft. long, 12 in. in diameter at its upper and 10 in. in diameter at its lower bearing, and having a hole 6 in. in diameter extending its entire length. Through this hole pass the shafts by which the observer at the eye end works the right ascension clamp and slow motion. The declination axis is also of steel, 10 ft. 6 in. long, 10 in. in diameter at its upper and 9½ in. at its lower bearing, and has a 4-in. hole extending through it. Bearings of Babbitt metal are provided for both axes, but much of the weight is carried by anti-friction rolls and an ingenious arrangement of "ball bearings." The telescope tube consists of a central section of cast-iron strongly ribbed, to which sections of sheet-steel are attached. When the telescope is horizontal the flexure of the tube with the object glass and permanent counter-balancing weights is $\frac{1}{4}$ in. only, while with a load of one ton added at each end the flexure is increased to $\frac{1}{2}$ in.

An observer at the eye end can perform the following operations:

1. Clamp in declination.
 2. Give slow motion in declination.
 3. Read the declination circle (2 verniers).
 4. Clamp in right ascension.
 5. Give slow motion in right ascension.
 6. Start or stop driving clock.
 7. Read the right ascension circle (1 microscope).
- An assistant on either side of the balcony can—
8. Clamp in declination.
 9. Give quick motion in declination.
 10. Give slow motion in declination.
 11. Clamp in right ascension.
 12. Give quick motion in right ascension.
 13. Give slow motion in right ascension.
 14. Stop or start driving clock.
 15. Read right ascension circle (2 microscopes).
 16. Read a dial showing approximate declination.

There are three permanent finders of 6 in., 4 in., and 2½ in. diameter respectively, and brackets are provided for attaching a 12-in. telescope belonging to the observatory when especially accurate pointing, as in some photographic work, is required. The eye end is further provided with a fine position micrometer made by Fauth & Co., and a stellar spectroscope by Brashear. The driving clock is in the upper section of the pier. The speed of the clock is regulated by a frictional governor of the cross-armed type and by an electric control, by means of which its rate is kept in agreement with that of a standard sidereal clock. One of the arbors, turning once in a minute, carries a chronograph drum.

For use as a photographic telescope a third (crown) lens of 33 in. clear aperture, weighing with the cell 150 pounds, is mounted in front of the visual objective, its application shortening the focal length of the telescope by 10 ft. An opening is therefore made in the tube 10 ft. from the eye end, and giving access to a plate-holder capable of carrying a plate 20 in. square, and provided with all the necessary adjustments. An image of the moon upon the plate is about 5½ in. in diameter.

The dome covering this great telescope is 70 ft. in diameter, and the floor can be raised vertically through a distance of 16½ ft. by four hydraulic rams. The observing slit is 9½ ft. wide, closed by two steel shutters, which are opened by a pull of 5 lbs. upon an endless rope. The cost of the visual objective was \$52,000, that of the photographic corrector \$13,000, while the mounting was furnished for \$42,000, and the dome and movable floor were put in place for \$73,300.

We have given a somewhat detailed description of this instrument for the reason that it may be regarded as embodying on a large scale all of the modern improvements and conveniences that have been introduced into telescope construction. Both Warner & Swasey and Fauth & Co. have furnished mountings for a number of Clark's smaller lenses, which are all that could be desired for ease of manipulation and steadiness.

Among improvements in astronomical instruments should be mentioned the "photoheliograph," a horizontal telescope of long focus, which was first brought into use by Prof. Joseph Winlock in 1869-70 at the Harvard College Observatory. A somewhat similar apparatus was previously suggested by Capt. Laussedat and others in France, but the peculiar advantages of this form of instrument for photographic observations of the sun do not seem to have been appreciated until the results of independent experiments at Cambridge had been published. Photoheliographs of 5 in. aperture and 40 ft. focal length, mounted in the meridian, were used by all the parties sent out by the United States to observe the transits of Venus of 1874 and 1880, and the superior results obtained by these parties seem to have justified the adoption of the "American method" of observation. A form of horizontal mounting for large reflectors, which appears to possess some of the advantages of Loewy's "equatorial coudé," was described by Mr. J. A. Hill at the meeting of the American Association for the Advancement of Science in 1871. The astronomer is enabled "to remain seated in one position, looking in one direction, and entirely protected from cold, fatigue, night air, etc." Prof. Pickering has used a horizontal telescope mounted at right angles to the meridian in his extensive photometric work, and for the continuation of this work to fainter stars he has recently had constructed by the Clarks an instrument of this kind of 12 in. aperture and 200 in. focal. The object glass is at the western end of the tube, and in front of it is placed a plane mirror, 18 in. in diameter, so mounted that the light of a celestial object not more than one hour either side of the meridian can be thrown into the field of the telescope. The eastern end of the tube, carrying the eye-piece, is covered by a small building, which can be warmed. An auxiliary telescope of 5-in. aperture is employed to bring into the field an image of the pole-star, which is reduced by polarizing apparatus to equality with the image of any star observed in the principal telescope. The angular apertures of the two telescopes are such that the emergent pencils may be coincident.

Photography has recently been developed into such a valuable accessory in astronomical observations that it becomes extremely desirable to provide means by which the ordinary visual objective may be readily transformed into a photographic objective, for the correction for chromatic aberration by means of the flint glass lens in the ordinary objective is too great to give

satisfactory photographic images. The method originally adopted by Rutherford and already mentioned in connection with the Lick glass, is to provide an additional convex lens of long focus, which may be placed over the ordinary objective when photographs are to be taken, and may be removed when direct observation is desired. Another method of getting rid of the excessive correction for chromatic aberration, suggested by Prof. Pickering, is to separate the flint and crown glass lenses and to place the flint nearer the eye-piece. While the color correction is in this way made satisfactory, the spherical aberration is only partially corrected, the focal length of the central part of the object glass being greater than that of the surrounding portions. This difficulty is, however, surmounted by making one surface of the crown glass lens much more convex than the other, and reversing it when the lenses are separated. An objective of 13 in. aperture ground in this way by the Clarks for the Harvard Observatory in 1857 has given most satisfactory results.

The principal makers of meridian circles, astronomical transit instruments, and zenith telescopes in America are Young, Würdemann (now retired), Stackpole, Buff & Berger, Fauth & Co., and Warner & Swasey. Fauth & Co. mounted in 1888 at the Cincinnati Observatory a 5½-in. meridian circle (object glass by Clark), the divided circle of which, as far as it has been investigated, compares favorably with the best of foreign make.

The following table will, perhaps, convey an idea of what may be expected of modern telescopes in "space-penetrating" or in "separating power;" the table gives the magnitude of the faintest star that telescopes of various apertures may be expected to show, and also the angular distance of the components of the closest double star that these apertures will just separate. [Note.—A star of about the 6th magnitude is the faintest visible to the unaided eye: a linear foot subtends an angle of 1" at a distance of about 39 miles.] The separating power was based by Dawes upon a number of experiments with small telescopes. The space-penetrating power is taken from Newcomb and Holden's *Astronomy*, and is computed upon the assumption that a star of any magnitude gives 2½ times the light of one of the magnitude next below.

Table of Space-penetrating and Separating Powers.

Aperture in inches.	Faintest star visible. Magn.	Least separable distance. "	Aperture in inches.	Faintest star visible. Magn.	Least separable distance. "
1.0	9.0	4.56	5.5	12.7	0.83
1.5	9.9	3.04	6.0	12.9	0.76
2.0	10.5	2.28	6.5	13.1	0.70
2.5	11.0	1.82	7.0	13.3	0.65
3.0	11.4	1.52	8.0	13.5	0.57
3.5	11.7	1.30	9.0	13.8	0.507
4.0	12.0	1.14	10.0	14.0	0.456
4.5	12.3	1.01	11.0	14.2	0.414
5.0	12.5	0.91	12.0	14.4	0.380

List of the Largest Reflectors in the World.

Observatory or Owner.	Aperture. Centi- metres.	In.	Constructed by
Lord Rosse, Birr Castle, Ireland,	153	72	Lord Rosse, 1844.
Bessemer, London,	128	50½	Bessemer.
Sir W. Herschel, Slough,	122	48	Herschel.
Lassell, Liverpool,	122	48	Lassell, 1860 (destr'd).
Melbourne Observatory,	122	48	Grubb, 1870.
Paris Observatory, Common, Ealing,	120	47	Martin, Eichens, 1876.
	94	37	Calver and Common, 1879.
Lord Rosse, Birr Castle,	91½	36	Lord Rosse.
Toulouse Observatory,	85	33½	Henry, Secretan.
Marseilles Observatory,	80	31½	Foucault, Eichens.
Harvard College Observatory,	71	28	H. Draper.

List of the Largest Refractors in the World.

Observatory or Owner.	Aperture. Centi- metres.	In.	Constructed by
Lick Observatory, Hamilton, Cal.	91½	36	Clark, Warner and Swasey, 1887.
Pulkowa, Nice,	76	30	Clark, Repsold, 1884.
Greenwich, Paris,	71	28	Henry, Gautier, 1886.
Vienna,	73½	27*	Grubb (constructing).
McCormick Observatory, Washington,	66	26	Martin (Eichens), Grubb.
Newall, Gateshead, Eng.,	66	26	Clark, 1883.
Princeton, Strassburg,	63½	25	Clark, 1873.
Milan,	58½	23	Cooke, 1863.
Dearborn Observatory, (near Chicago),	48½	18*	Clark, 1881.
Dr. Van Duzee, Buffalo,	48½	18*	Merz, Repsold, 1879.
Warner Observatory, Rochester,	47	18½	Merz, 1879.
Carleton College Observatory, Minn.,	47	18½	Clark, 1863.
Washburn Observatory, Madison, Wis.,	40½	16	Fitz.
Dun Echt Observatory (Lord Lindsay),	40½	16	Clark, 1880.
Harvard College Observatory,	40½	16	Clark, 1880.
Pulkowa Observatory, Paris	40½	16	Brashear (construct'g).
Lisbon	39½	15½	Clark, 1879.
Huggins, London,	38½	15½	Clark, 1875.
Brussels Observatory, Bordeaux	38	14*	Merz, 1843.
Litchfield	38	14*	Merz, 1840.
Clinton, N. Y.,	38	14*	Lerebours, Bruaner, 1854.
Markree Castle, Ireland,	38	14*	Merz, Repsold, 1861.
Columbia College, New York,	38	15	Grubb, 1871.
Dudley Observatory, Albany,	38	14*	Merz, Cooke, 1880.
Harvard College Observatory,	38	14*	Merz, Eichens, 1880.
Catania-Etna, Greenwich,	34	13½	Spencer and Eton.
Ann Arbor, Mich.,	34	13½	Cauchois, Grubb, 1834.
Vassar College, Poughkeepsie, N. Y.,	33	13	Rutherford.
Morrison Observatory, Oxford, Eng.,	33	13	Fitz.
Cambridge, Eng.,	33	13	Clark.
Dublin,	32½	12*	Merz, 1877.
Radeliffe Observatory, Oxford,	32½	12*	Merz, Troughton and Simms, 1860.
Middletown, Conn.,	32	12½	Fitz.
S. V. White, Brooklyn, N. Y.,	31½	12½	Fitz (reworked by Clark).
Allegheny, Pa.,	31½	12½	Clark, 1876.
Harvard College Observatory,	31	12½	Grubb, 1875.
Vienna,	31	12½	Cauchois.
U. S. Military Academy, West Point,	30½	12	Cauchois (1825)?
Lick Observatory,	30½	12	Cauchois.
B. von Engelhardt, Dresden,	30½	12	Clark, 1869.
	30½	12	Clark (reworked, 1867).
	30½	12	Fitz (reworked by Clark, 1874).
	30½	12	Clark (H. Draper, 1876).
	30½	12	Clark, 1888, (horizontal telescope).
	30½	12	Clark, 1876.
	30½	12	Clark, 1884.
	30½	12	Clark, 1861.
	30½	12	Grubb, 1880.

* Paris inches.

Where two makers are given, the first made the objective, the second the mounting. (w. c. w.)

TEMPERANCE REFORM. The beginning of the modern temperance movement may be traced to the publication, in 1785, of a work by Dr. Benjamin Rush, entitled *An Inquiry into the Effects of Ardent Spirits upon the Human Mind and Body*, which made a profound impression on thoughtful readers, and led in no long time to organized efforts for the suppression

of intemperance. There was abundant need; for though, from an early period in the history of the country, legislation had been directed to restricting the sale of intoxicating drinks, the evil had increased till it reached a portentous height. Strong drink was thought indispensable to laboring men. It was essential to reputable hospitality. It was plentifully supplied at weddings and at funerals, and even at ecclesiastical gatherings. Dr. Lyman Beecher describes an ordination which he attended early in his ministry in Connecticut. "The preparation for our creature comfort, besides food, was a broad sideboard covered with decanters and bottles, and sugar and pitchers of water. There we found all the various kinds of liquors then in vogue. The drinking was apparently universal. The preparation was made by the society as a matter of course. When the consociation arrived they always took something to drink round; also before public services, and always on their return. As they could not all drink at once they were obliged to stand and wait, as people do when they go to mill. There was a decanter of spirits also on the dinner-table to help digestion, and gentlemen partook of it during the afternoon and evening as they felt like it, some more and some less; and the sideboard, with the spillings of water and sugar and liquor, looked and smelled like the bar of a very active grog-shop. None of the consociation were drunk, but that there was not at times a very considerable degree of exhilaration I cannot affirm." One or two such scenes were enough to move Dr. Beecher powerfully, and the result was an organization proposed by the General Association for diminishing the use of spirits and for the reformation of manners. Similar action was taken about the same time by the General Assembly of the Presbyterian Church; and in 1811 the General Association of Massachusetts appointed a committee to co-operate with the committees of the Connecticut Association and the Presbyterian Assembly. Nothing more was proposed at this time than to restrain the *excessive* use of ardent spirits.

In 1813 the "Massachusetts Temperance Society" was formed—organized at first as the "Massachusetts Society for the Suppression of Intemperance;" the name subsequently adopted was indicative of more positive purposes, that were not long in being developed. In 1826 the "American Society for the Promotion of Temperance" was founded at Boston. Dr. Justin Edwards was appointed in 1829 corresponding secretary of this society, and travelled extensively, advocating total abstinence and forming State and local societies. This society later adopted the name, "The American Temperance Union," and has since been reorganized as the "National Temperance and Publication Society." The first national temperance convention, held in 1833, resolved "That the traffic in ardent spirits as a drink, and the use of it as such, are *morally wrong*, and ought to be abandoned throughout the world." But the movement had by this time acquired a momentum that made an advance necessary. In 1836 the national convention declared for total abstinence from all intoxicating drinks, and this became a settled "principle" of organized temperance. A powerful effect was produced upon the public mind. As a rule, the ministers of the different denominations and a large proportion of the communicants in the churches became pledged "teetotallers." Society took on a new face, and over a large part of the country the volume of the liquor traffic was materially diminished.

Up to this time the effort had been to prevent the formation of the drinking habit, by getting the young pledged against it. It was assumed that drunkards were irreclaimable. But in 1840 six men of intemperate habits in Baltimore signed a total abstinence pledge and founded the "Washington Temperance Society." The "Washingtonian" movement spread rapidly over the country, and it has been computed that 150,000 intemperate men were led to abandon

their cups. It was asserted, however, by observers of the movement that to a painful extent the reformation proved but temporary and was followed by relapses. More recent efforts in this direction have taken the form of what is termed "Gospel Temperance," in which it is sought to strengthen the moral appeal by the awakening of religious motives. In 1842 the order of the "Sons of Temperance" was formed, and in 1852 the order of "Good Templars," societies that have branched extensively and have had numerous imitators, in which the temperance principle is supposed to be reinforced by the machinery of lodges, pass-words, grips, and regalia, with pledges of mutual assistance.

But while very great and gratifying success had been gained, it was painfully evident that it was incomplete. There were still drunkards, there were still moderate drinkers who, in the general opinion of temperance men, were drunkards in the making, and there seemed to be no hope of abolishing the evil but by outlawing it. Massachusetts in 1838 passed an act prohibiting the sale of liquors in less quantity than 15 gallons, but it was repealed in 1840, leaving in force the former law forbidding the sale by unlicensed persons of liquor in less quantity than 28 gallons. Licenses were granted by city governments and by county commissioners. In 1843-46 a movement began for the election of commissioners opposed to license, and thus, without any change of the law, the sale of liquor became illegal in all the counties and cities of the commonwealth. A strong anti-license feeling was developed in New England, and rapidly spread through New York, Pennsylvania, Ohio, and several of the North-western States. But it was found that law, administered by the ordinary judicial processes and the ordinary rules of evidence, was ineffectual to arrest the traffic, and hence was originated a more inquisitorial law, raising presumptions against the accused in view of certain defined circumstances—a so-called prohibitory law, armed with heavier penalties. The first prohibitory statute was passed by Maine in 1851. With some modifications it has continued in force to the present time, and is generally approved by the people without distinction of party. Massachusetts followed the example by a similar act in 1852, which was soon repealed. But an act was passed in 1855 which proved impervious to legal criticism, passed the ordeal of the courts, and was declared constitutional by the U. S. Supreme Court. It continued in force 20 years, having been repealed in 1875. A local option law was substituted, under which every city and town (township) votes annually for or against license. As a rule a majority of the cities vote for license and a majority of the country towns against it. The result is that the sale is prohibited over two-thirds of the State. Between 1850 and 1860 prohibitory laws were passed by New Hampshire, Vermont, Connecticut, Rhode Island, Michigan, Ohio, Indiana, Illinois, Iowa, and Wisconsin; also in New York, where, however, it was declared unconstitutional by the Court of Appeals, and a license law was substituted.

The decade after 1850 was the period of highest success in all branches of temperance effort. The civil war had an unfavorable effect. While on the one hand there was a reaction from the theory and practice of total abstinence, there was on the other so complete absorption in the excitements of the war as to make the people unmindful of the change. The reaction was promoted by publications questioning the duty of total abstinence from fermented liquors. Foreign immigration had its effect, causing a manifest change in the character of our population. The wine of California and the products of foreign and domestic breweries powerfully solicited the appetites of the people. In 1840 the consumption of malt liquors per capita was 1½ gallons; in 1860, 3½ gallons; in 1880, 8½ gallons; in 1882, 10 gallons. Nevertheless, the friends of abstinence have not been disheartened, but hold

the most advanced ground. New Hampshire and Vermont retain their prohibitory laws, and some Western States. The local option system has had considerable success in the South, particularly in Georgia, though it seems difficult to keep the public mind steadily up to the work. The apparently capricious changes from prohibition to license and *vice versa* has led the friends of total abstinence to agree very generally in support of constitutional prohibition.

Kansas was the first State to embody in her constitution an article prohibiting the manufacture and sale of intoxicating liquors. Similar amendments have been put into the constitutions of Maine, Rhode Island, and Iowa; the Iowa amendment was annulled by the judiciary as not legally submitted to the popular vote. It is not easy to see the superiority of this method over statutory prohibition. No constitution executes itself; it can only be carried into effect by legislation appointing the process of enforcement and affixing penalties. The "statute in that case provided" is the operative measure. The prohibitory force of the statute is all the force that can be directed against the traffic, whatever superfluity of energy may be supposed to inhere in the constitution. In Rhode Island, the first Legislature that sat after the amendment was made was roundly accused of having virtually nullified the article, and a great popular agitation arose. Whatever may have been the fact in that case, it is clearly in the power of any Legislature, under color of carrying constitutional prohibition "into effect," to make laws as ineffectual as possible, whenever public opinion sets in that direction. Wisely or unwisely, however, the standard of prohibition by constitutional amendment is "full high advanced" as the sign in which they are to conquer, by all Prohibitionists in every part of the country. A prohibitory amendment to the Constitution of the United States is the ultimate aim.

A political party devoted to the cause of Prohibition as the one thing needful was a natural outcome of the agitation. The Prohibitory party, after some local enterprises, entered the field of national politics in the Presidential election of 1884. They chose no electors, of course, but they polled about 150,000 votes, and with extraordinary elation extended and perfected their organization with a view to further operations as a national party. In the Presidential canvass of 1888 they redoubled their energy and agitation on the "stump," through the press, and by the circulation of "documents." Success in electing their candidates was not claimed as probable. That was modestly deferred to the election of 1892. But the mark aimed at was a million of votes. The number cast was 257,243, a gain of 70 per cent. over the result in 1884.

Meanwhile an increased attention began to be given to what is termed "High license," as an expedient for restraining and diminishing the sale of intoxicants. The exaction of a large license fee as a minimum, coupled with stringent conditions, tends to restrict the number of licensed dealers, who are thus more easily kept under lawful supervision. At the same time the revenue derived from the traffic is some compensation for damages due to it; though it must be allowed that there is force in the objection, that for municipalities to derive a revenue from the traffic operates as a mercenary motive to license it. Where, as in Pennsylvania, the licensing power is committed to judges, the system has worked with beneficial effect. It is a question still disputed whether in other localities high license has had the effect to diminish the consumption of intoxicating drinks. Many friends of temperance favor it; Massachusetts has adopted it, and it is evident that the system must have its trial and abide the verdict from experience. Besides laws in restraint of the sale, a number of the States have adopted civil damage laws, the effect of which is to make the dealer in intoxicating drinks liable in damages for any injury resulting from the sale.

In 1873 the public mind was electrified by tidings

of a Woman's Crusade against the saloons, beginning in Ohio and spreading into the neighboring States. At first the grog-sellers covered before the unexpected invasion, but recovering themselves they opposed this extra-legal assault. The agitation would probably have soon spent its force if opportunity had not been seized to transfer its energy into a well-devised organization under the name of the "Woman's Christian Temperance Union," which has become one of the recognized forces in the temperance warfare, and has extended its operations to the promotion of other reforms. The Union has done much to promote the education of the young in the principles and habit of abstinence; to secure legislation requiring such instruction in the public schools; and to add to the moral momentum of the temperance agitation. Of late, as a national organization, it has become an ally of the Prohibition party, and has declared for woman suffrage, which is espoused also by the Prohibitionists.

Total abstinence is a theory and a policy. As a theory it has had a remarkable evolution. At first, in view of the sin and misery of drunkenness, and the exposedness of men to temptation, abstinence was urged as the only security against the always impending peril. All drunkards, it was said, were once moderate drinkers, and none of them intended to become drunkards. And even if one could drink without peril to himself, he was besought from love to his neighbor to take the pledge with him and help him to keep it. Prudence and benevolence were the chief motives appealed to, and with remarkable success. These pleas were strengthened by evidence of economic damage and the social and moral evils resulting from intemperance. But, as early as 1833, as we have seen, a national convention resolved that "the use of ardent spirits as a beverage and its sale for that purpose are *morally wrong*." This empirical dictum of ethics was *resolved*, and now it is apparently assumed on all hands as needing no proof, that any sale or use of intoxicating liquors is a sin. But a large proportion of temperance men are also sincerely religious men, and reverence the Bible as an authority on moral questions, and it is but too obvious that on this ground the Bible is chargeable with the approbation of sin. To evade collision between their ethical theory and their faith in the Scriptures, the notion has been bruited and has found considerable currency, that there were in ancient times two kinds of wine, one unfermented and harmless and the other fermented and pernicious; and that when the Bible commends wine it means the harmless kind, but that when it speaks unfavorably of wine it refers to the fermented sort. The late Prof. Moses Stuart and Pres. Eliphalet Nott were the first vouchers for this strange theory. The scholarship of the age has repudiated this futile method of interpreting the sacred texts. It remains for its advocates to revise either their ethical dicta or their mode of interpreting and applying the Scriptures, or perchance to modify both. A development in another direction has been observable, though not perhaps distinctly formulated: a tendency to regard the drunkard not as guilty but as simply the victim of the liquor-seller. The latter is summarily described as a drunkard-maker. That an intemperate man has any responsibility for drinking is, if not denied, apparently forgotten.

As a policy, the temperance movement began its course as simply a moral reformation. The effort was to persuade men to leave off the use of intoxicating drinks, to give up the traffic, and to throw their social influence on the side of abstinence. Arrayed against it was the strength of appetite, of custom, and of the law. The form of license assumed that the sale of intoxicants was for "the public good," and applicants for license were required to furnish certificates to their "good moral character." The advocates of temperance faced this front of opposition, and by the force of their moral appeals won to their side the clergy, the churches, and a large proportion of the educated

and respectable, including no small part of the laboring classes, especially of skilled laborers. A great diminution in the sale and use of liquors was the result. But now a new purpose was taken up, which was nothing less than to *suppress everywhere* the manufacture and sale of intoxicating drinks. Hence law, more law, and, finally, constitutional law, have been invoked, and until the desired end is reached the agitation is to go on. Whether this is not an utterly impracticable purpose; whether any law can be devised that will prevent men from gratifying the appetite for stimulants as long as the appetite exists; are questions to which in their present temper the leaders in the temperance warfare will scarcely vouchsafe a hearing. But those who are willing to think may be led to doubt whether legal penalty is superior to, or in any degree a substitute for, the appeal to moral, religious, and affectional motives, and the cumulative force of enlightened public sentiment—whether in short there is any more effective prohibition than a man imposes upon himself.

There are many earnest temperance advocates and workers who cannot believe it right to proscribe wine, which our Lord and his apostles used, and which is made a symbol by the Holy Spirit of spiritual joy. Hence, they will not join in any movement of teetotalism or prohibition which is indiscriminating in this regard. They are ready to use every reasonable means to diminish the evils that come from the excessive use of intoxicants, and to put heavy restraints upon the sale of distilled liquors. These temperance advocates also are opposed to the one-sidedness of a reform that puts one sin forward out of all proportion to other sins and so tempts many to suppose that if this sin is avoided the man is renewed. They believe all sins should be classed together as odious to God and injurious to man, and that the social vice, greed for wealth, and fraud are doing as much to destroy society as is intemperance. Against all every effort should be put forth for their overthrow and the establishment of righteousness.

The temperance movement was carried beyond the Atlantic, and appeared in Scotland in the formation of a temperance society near Glasgow in 1829; the first total abstinence society was formed at Dunfermline in 1830. The first temperance society in Ireland was organized at New Ross, County Wexford, in 1829; the first total abstinence society at Strabane, in 1835. The celebrated Father Theobald Mathew began at Cork, in 1838, those labors which made his name a household word in the Old and the New World. He rapidly extended his labors to all parts of Ireland with such effect that the society formed by him contained in 1840 1,800,000 persons pledged to total abstinence. The consumption of whisky in Ireland fell from 12,500,000 gallons in 1838 to 6,500,000 in 1841. In 1843 the number of persons pledged to total abstinence through the labors of Father Mathew in Ireland and in Great Britain exceeded 5,000,000. In England, beginning in 1830, local associations were formed at Bradford, Manchester, Liverpool, and Leeds. "The British and Foreign Temperance Society" was formed in 1831, with the patronage of the Bishop of London, and the support of many persons high in rank and official station, pledged to abstain from distilled spirits except for medicinal purposes. Total abstinence and "teetotal" societies were formed in 1835. "The New British and Foreign Temperance Society," formed in 1836, had originally two pledges, but in 1839 the total abstinence pledge was adopted. Both general societies adopted this pledge in 1840, and a great impulse was given to the movement. The cause has since been carried forward by the agency of several efficient organizations in different parts of England, laboring by means of lectures, publications, and petitions to Parliament. The "United Kingdom Alliance," formed in 1853, aims at "the total and immediate suppression of the traffic in all intoxicating liquors as a beverage,"

though the practical efforts it has put forth have been for the enactment of the "Permissive Bill," corresponding nearly to our local option laws. It proposes to prohibit the licensing of the traffic in any parish in which two-thirds of the rate-payers shall so determine. This moderate and reasonable measure stands no chance of being enacted at present. Great as has been the increase of pledged abstainers, the movement is far from having permeated religious and general society to the extent that it has in this country.

Whatever opinion may be entertained of the theories or the policies of organized temperance, it cannot be doubted that a highly beneficial change has been produced in the habits of the people. During forty years, from 1810 to 1850, there was a very great reduction in the quantity of intoxicating liquors consumed in the country. Of distilled spirits the consumption fell from 4.6 gallons to 2.5 gallons per capita, and, including all intoxicants, there was a decrease per capita from 8 to 4.1 gallons. It would be a great error to suppose that the real strength of temperance principle is to be measured by the number of political prohibitionists. It is not uncommon to find persons who have grown up to mature manhood without having ever known the taste of intoxicating drink, or feeling the slightest inclination to acquire it. The great body of moral and intelligent men and women of our native stock are abstainers from principle, and much as our composite population now complicates results, an assimilation is going on among the foreign elements of our commonwealth to the native American standard.

The literature of Temperance is enormous. Beginning with Dr. Rush's pamphlet (1785), Dr. Heman Humphrey's *Six Sermons* (1810), and Dr. Lyman Beecher's *Six Sermons on Intemperance* (1785), the reverberation of which went literally around the world, it includes discourses and essays by leading ministers of all denominations, and by eminent civilians and jurists, reports of national and local organizations, some of them productions of eminent ability and permanent value, and discussions in periodicals. Of recent works two are of special value: *History of the Temperance Reform*, by Hon. Henry W. Blair, and *The Liquor Problem in All Ages*, by Daniel Dorchester, D. D. (L. E. S.)

TEMPLE, FREDERICK, English bishop, was born at Santa Marra, Nov. 30, 1821. He was educated at Balliol College, Oxford, and graduated B. A. in 1842, being then elected fellow and mathematical tutor of his college. He was ordained priest in 1847 and became principal of Kneller Hall Training College from 1848 to 1855. In 1858 he was appointed head-master of Rugby School and discharged the duties of this position with marked success. He was one of the seven authors whose *Essays and Reviews* (1860) revealed the increase of Broad church views and rationalistic tendencies in the Church of England. His essay was on "The Education of the World." He also published three series of *Sermons Preached in Rugby Chapel* (1862-71). In 1869 he was made bishop of Exeter, and in 1885 he was transferred to the see of London. He was select preacher at Oxford in 1873, and Bampton lecturer in 1884.

TENNENT, GILBERT (1703-1764), and WILLIAM (1705-1777), were sons of Rev. William Tennent, a Presbyterian minister who emigrated from Ireland in 1718, and founded a "log college" near Philadelphia for the training of students in divinity. Gilbert, after teaching and being taught there, was ordained pastor of a Presbyterian church at New Brunswick in 1726. Here his brother William while studying theology fell into a trance and was for some days supposed to be dead. He revived, however, and afterwards declared that he had been admitted to heaven and gave some description of his vision. Meantime he had lost his knowledge of earthly things and had to be trained as a child. Having fully recovered he was in 1733 ordained pastor of a church at Freehold, N. J., and there continued until his death, March 8, 1777. Gilbert in 1740 at the request of Whitefield became an evangelist and travelled in New England. His doctrinal

peculiarities and perhaps his eccentricity in dress and manner roused opposition to him and the Presbytery of New Brunswick was divided. In 1743 he founded a church at Philadelphia but still travelled widely. The Log College had been merged in Nassau Hall at Elizabethtown, N. J. and afterwards at Princeton, and in behalf of this institution Tennent went to England, Scotland, and Ireland in 1753, and obtained liberal donations. He died at Philadelphia, July 23, 1764. He had published many sermons and an account of the revival of religion in 1741.

TENNYSON, ALFRED, BARON, the representative poet of the Victorian era in English literature, was born at Somersby, a small hamlet of Lincolnshire, Aug. 6, 1809. He is the third of seven sons in a family of twelve children. Lord Tennyson is descended, through the Barons D'Eyncourt, from the ancient and illustrious Norman Plantagenets. The poet's father, the Rev. George Clayton Tennyson, LL. D. (d. about 1831), rector of Somersby and vicar of Grimsby, was notable in many ways. He was a striking, impressive man of great strength and stature, an excellent mathematician and linguist, something of an architect, musician, painter, and poet, and, withal, a man of fine character, "high-souled, high-tempered." Tennyson's mother was Elizabeth, daughter of the Rev. Stephen Fytche, vicar of the neighboring parish of Louth, "a sweet, gentle, and most imaginative woman, exceedingly tender-hearted, intensely, fervently religious—as a poet's mother should be." Thus the genius of Alfred Tennyson, shared, as it was, in some measure by most of his many brothers and sisters, would seem to be inherited in some degree from each of his parents; for if the fine physique, the scholarly tastes, the high character, and the artistic temperament of the illustrious son are traceable to his father, surely his surpassing imagination and his unspeakable tenderness—without which his greatness as a poet would have been impossible—are as plainly traceable to his mother.

Dr. Tennyson's "handsome children had beyond most children that wondrous toy at their command which some people call imagination." They were given to games typifying the exploits of legendary kings with their retinues of knights, and beguiled their happy childhood with tales and romances of their own making fashioned after mediæval models.

As to Tennyson's education, the central fact is that he has been pre-eminently self-taught. Not that he lacks regulation teachers and tutors, but that he early began to supplement their instruction by self-instigated reading, observation, and reflection; and that he has shown from boyhood a growing independence of mind and character. Early in life he as good as recorded of himself that knowledge to him was beautiful, and that he loved it "for its beauty." To any one with the slightest appreciation of Tennyson's love for the beautiful this autobiographical bit is sufficient to account for the powerful affinity his mind has ever shown for knowledge. Such a soul, after a first start, may safely be left to itself. This start in Tennyson's case was obtained largely at home under the tuition of his father, though he attended for a time Cadney's village school, and for a brief period the grammar-school at Louth. The young lad's poetical bent was greatly stimulated by the similar bent of his elder brothers, Frederick and Charles, both of whom have written verse of much merit. As boys they were all great readers of poetry, ancient and modern, Alfred being particularly partial in those years to Scott and Byron; and they were all furthermore copious writers of metrical compositions. Alfred's boyish efforts were very numerous.

In 1827 Charles and Alfred published selections from their accumulated productions, under the title, *Poems by Two Brothers*. This little book, for which the young authors received from their publishers £10, contained 225 pages, and bore on its title-page the disclaimer quoted from Martial, "*Hæc nos novimus esse nihil*."

The preface explained that the poems were composed not jointly but individually, and that they were written between the ages of fifteen and eighteen. The body of the work is remarkable for its numerous foot-notes and quotations from ancient and modern poets—but chiefly for the entire absence of anything characteristic of the later work of England's Laureate. The volume is interesting chiefly as showing the 'prentice hand of Alfred Tennyson. The critics of that day, with one exception, passed it by in utter silence. That it contained little or nothing worthy, on its own merits, of further perpetuation is now the practically unanimous verdict, Tennyson's not excepted; for he has never seen fit to reprint or to publicly acknowledge so much as a single poem contributed by him to this first volume.

About 1828 Alfred, with Charles, removed to Trinity College, Cambridge, where the eldest brother Frederick had just taken the Chancellor's medal for his Greek poem, *Egypt*. Here Alfred soon became a recognized leader among a circle of young collegians remarkable for high character, and for vigor and brilliancy of intellect. Among them were Arthur Henry Hallam, who will be forgotten only when *In Memoriam* fails for readers; Lord Houghton, then Richard Monckton Milnes, sometimes styled the "Mæcenas of his time;" Richard Chenevix Trench, afterwards Archbishop of Dublin; Henry Alford, James Spedding, Merivale, the historian; Edward Fitzgerald, and Kinglake. Thackeray, for years a warm personal friend and a great admirer of Tennyson, was also a fellow-student at Cambridge; their close intimacy, however, seems to have dated from a subsequent period. Alfred's tutor at college was William Whewell, "a man who is well known to have stripped the tree of knowledge and tasted most of its substantial fruits." Tennyson and others of the students above mentioned belonged to an undergraduate society commonly known as the "Cambridge Apostles," from the limitation of its active members to twelve; the main object of which was full and frank discussion of those questions which, in the bold and vigorous minds of its members, were pressing for solution. It appears probable that Tennyson in his university career was much more given to wooing the muses than to pursuing any prescribed routine course of study; but it is also probable that in disregarding conventionalities he was consciously following the mandates of his own genius, which, however lawless it might make him appear to others, was an all-sufficient law unto itself. When at length he quitted the university it was without a degree. The same was true of Thackeray. Thus the two most widely known Cambridge men of this century left their *alma mater* without the customary seal of their fidelity and of her approval—but destined to win loftier honors and more enduring laurels than any ever won or bestowed in college.

In 1829 Tennyson was awarded the Chancellor's medal for his poem *Timbuctoo*, one of the unsuccessful competitors being his nearest friend, Arthur Hallam. The poem received a very flattering notice from the *Athenæum*. The author did not, however, include it in subsequent collections of his poems.

In 1830, while still at Cambridge, Tennyson published his *Poems, Chiefly Lyric*. This volume contained *Lilian, Isabel, Mariana, The Mermaid, The Mermaid, The Owl, Recollections of the Arabian Nights, Ode to Memory, The Poet's Mind, The Deserted House, The Ballad of Oriana, The Sea Fairies, Nothing Will Die, All Things Will Die, The Dying Swan*, together with twenty-five poems which the author did not republish in subsequent collections. All the "rejected poems"—indeed, every collectable scrap Tennyson has ever written—now appear in recent American editions. The volume of 1830 soon drew the fire of the critics, from some of whom it received hearty though discriminating praise.

As originally proposed the "Poems" were to have been a joint publication by Tennyson and Arthur

Hallam as a memorial of their friendship. This plan was abandoned at the suggestion of Hallam's father. Hallam, however, reviewed his friend's volume in an essay "On some of the Characteristics of Modern Poetry, and on the Lyrical Poems of Alfred Tennyson," which appeared in the *Englishman's Magazine*. To those who would account for Tennyson's surpassing affection for his friend this essay is exceedingly interesting. Hallam notes five distinct excellencies in Tennyson's manner: his luxuriance of imagination and his control over it; his power of embodying himself in ideal characters; his vivid picturesque delineation of objects, and the peculiar skill with which he holds all of them fused in a medium of strong emotion; the variety of his lyrical measures, and exquisite modulation of harmonious words and cadences to the swell and fall of the feelings expressed; the elevated habits of thought, implied rather than directly expressed, and more impressive than if the author had drawn up a set of opinions in verse, and sought to instruct the understanding rather than to communicate the love of beauty to the heart. Hallam's prophetic allusion in verse to his companion is worthy of mention:

"A friend, a rare one,
A noble being full of clearest insight,
Whose fame
Is couching now with pantherized intent,
As who shall say, I'll spring to him anon
And have him for my own."

Leigh Hunt paid Tennyson's first volume the compliment of an extended review. Yet the poet's course has not been a continuous ovation. Even Coleridge wrote: "The misfortune is that he has begun to write verses without very well understanding what metre is."

About this time Tennyson and Hallam made a journey to the Pyrenees in the interest of the Spanish patriots driven into revolt by the tyranny of Ferdinand. They were the bearers of money and of despatches in invisible ink to the conspirators who were then hiding in the mountains. This episode is referred to in *In Memoriam*, *In the Valley of Caunteretz*, and in the poet's letter to his commentator, Mr. Dawson, of Montreal.

In the winter of 1832 a second volume appeared, containing thirty poems; among them *The Lady of Shalott*, *The Miller's Daughter*, *Enone*, *The Palace of Art*, *The May Queen*, *The Lotus Eaters*, and *A Dream of Fair Women*. Of this little book one of the most competent of modern critics (himself a poet) has said: "All in all, a more original and beautiful volume of minor poetry has never been added to our literature." It is difficult for those whose memories cover only that portion of Tennyson's career since his powers have been abundantly acknowledged and his fame assured to realize that there was a time when not merely the world but the majority even of the readers of poetry were quite indifferent to the feasts which he prepared for them; that a taste for such spiritual delicacies had actually to be cultivated, and that right slowly and painfully. Such is the case, however, as is shown in the world's willingness to let ten years elapse before calling for a second edition of this exceptional volume. Here and there, however, might be found a man, and, very rarely, even a critic, who regarded Tennyson as the chief living hope of the muses.

In 1833 Arthur Hallam, the poet's brother in the kinship of sympathy—and the betrothed lover of his sister Emily—died while absent in Vienna. This bereavement, so sudden, sharp, and unexpected, following fast upon other similar visitations, produced a most profound impression on the sensitive, thoughtful mind of the poet, bringing him face to face and at closest quarters with the awful Sphinx, propounding the great riddle—Death—and the even greater riddle—Life. Tennyson's answer—and no grander has been recorded in our age—is to be found in *In Memoriam*. The ten years following 1832 was a period of silence, though by

no means one of inactivity. The poet's life during these ten years was one of the greatest seclusion. "Avoiding general society, he would prefer to sit up all night with a friend, or else to sit and think alone. Beyond a very small circle he was never met." This circle, however, was as select as it was small. It included Thackeray, Landor, R. H. Horne, Carlyle, Sterling, Macready, Cunningham, Forster, and Mill. Tennyson and Carlyle used to have sundry "wit combats," "interlarded," according to their own accounts, with "brilliant flashes of silence." At length the plodding poetic world so far caught up with her great apostle as to demand a new edition of his poems. This was met in 1842 by the publication of a selection from the contents of his two previous books, carefully revised, with several new poems, among which were *Lady Clara Vere de Vere*, *The Blackbird*, *The Goose*, *Ulysses*, *Love and Duty*, *The Two Voices*, *The Talking Oak*, *Morte d'Arthur*, *The Gardener's Daughter*, *Dora*, *St. Simeon Stylites*, *Locksley Hall*, *Golconda*, and part of *The Day Dream*. The reception given these two volumes by the most thoughtful of the English-speaking race everywhere was prompt and appreciative. Fine as had been the quality of his previous work, it was seen that he had improved even upon that. Three further editions of the "Poems" were called for within four years, and Moxon, his publisher, said, as early as 1843, that Tennyson was the only poet by whom he had not lost. About this time the future laureate met, for the first time, his great predecessors. The high opinion of each respecting the other is shown in one of Wordsworth's letters to Prof. Henry Reed, of Philadelphia, in which he says: "I saw Tennyson when I was in London several times. He is decidedly the first of our living poets. You will be pleased to hear that he expressed in the highest terms his gratitude to my writings."

One thoroughly human phase of genius is well shown in the "literary squabble" between Bulwer-Lytton and Tennyson which followed the bestowal of a pension upon the latter in 1845. The curious may learn particulars by referring, in old editions, to *The New Timon*; a *Romance of London*, and to Tennyson's rejoinder, *The New Timon and the Poets*. But the wrath of the truly great is apt to be as momentary as it is intense. The *After-thought*, since rechristened *Literary Squabbles*, following speedily upon Tennyson's *New Timon*, shows his humility as well as his wisdom in such matters. A further sequel to this episode is to be found in Tennyson's dedication of his *Harold*.

In 1847 *The Princess* appeared; a poem well worthy of profound study by all who find themselves perplexed over the question of woman's proper "sphere." Three important events mark the year 1850. On June 13 Tennyson was married to Miss Emily Sellwood, whose mother was a sister of Sir John Franklin. The bride was "the near, dear, and true" of *The Dedication* in *Enoch Arden*. She proved a woman eminently qualified to have in her keeping a poet's comfort and happiness. Few men of letters have been so singularly fortunate in the choice of a helpmeet. The second event of 1850 was the publication of *In Memoriam*. Those who make of this work merely a monument to Arthur Hallam's memory underestimate its weighty import. Such a monument it is, of course, but it is vastly more: it is Tennyson's rendering of Job—destined to endure as long as men turn for enlightenment and consolation to the scriptures of the nineteenth century. *In Memoriam* instances well the slow and painful evolution of those things which are vital and lasting. Even a Tennyson took seventeen years to write *In Memoriam*; and the sadness and sorrow of some of those years are a subject too sacred to be publicly intruded upon. It was in 1850 that Tennyson succeeded Wordsworth as poet-laureate, an office which he has greatly honored, though not by the amount of work done strictly in his official capacity. The best known of his

laureate poems are the *Ode on the Death of the Duke of Wellington*, and *The Charge of the Light Brigade*.

In 1835 appeared, with other poems, the monodrama *Maud*, the full-blown blossom of which the stanzas "Oh, that 'twere possible," so rapturously alluded to by Mr. Swinburne, had been the beautiful bud. This fair flower of Tennyson's genius was eighteen years in opening. Those who feel the need of help in arriving at the true meaning of *Maud*, which has been much misunderstood, may find the essay of Dr. R. J. Mann of assistance; this essay received high commendation from the poet.

The *Idylls of the King* afford another instance of the slow growth of great works of art. The germ from which these sprang had a very definite existence in the mind of the poet at an early period; the maturing of the product of that germ was well-nigh the work of a lifetime. The first instalment of the *Idylls* appeared in 1859; four more were added in 1869, while the series complete was not given to the world until 1872. These Arthurian poems, constituting as they do in a very real sense an epic, are by many considered the poet's masterpiece. Of *Guinevere* Bayard Taylor has said that it would die only with the language in which it was written.

Enoch Arden, with other poems, came out in 1864. This poem, translated as it soon was into French, German, and even into Latin, has been so widely read that its very title has passed into a proverb. In 1870 appeared *The Window, or the Songs of the Wreath*, with music by Arthur Sullivan.

Tennyson's work as a dramatist comprises *Queen Mary* (1875); *Harold* (1877); *The Falcon* (1879); *The Cup* (1881); *The Promise of May* (1882); and *Becket* (1884). The dramas are often spoken of as the Laureate's "least successful" work. Curiously enough many criticisms of them seem based on the preconceived notion that Tennyson could not write a drama. Others have thought him, with his weight of nearly threescore years and ten, too far advanced in age to attempt the gathering of fresh laurels in a new field. Nevertheless, some of the dramas are highly regarded by sundry good authorities, and the author, it is said, believes them to contain his best work.

In 1879 *The Lover's Tale*—written in 1829, privately printed in 1833, pirated and misprinted in 1875—was reluctantly placed at the disposal of the public, together with its sequel, *The Golden Supper*. In 1880 the richly various volume, *Ballads and other Poems*, came out, evidencing the singular persistence of Tennyson's powers. Concerning *Rizpah*, in this collection, Mr. Swinburne says: "If after a thousand years all trace of all his poems had vanished from all human record save only these eighty-six lines of *Rizpah*, proof positive and ample and overflowing would be left in the survival of these that in him, if ever upon earth, a great poet had been born. . . . Never since the very beginning of all poetry were the twin passions of terror and pity more divinely done into deathless words. . . . The poet never lived on earth whose glory would not be heightened by the attribution of this poem to his hand." This is high praise, and it proceeds from a high source; from a rival, it might be said, were rivalry possible in the highest art.

Tiresias and Other Poems, dedicated to Robert Browning, appeared in 1886, and also in the same year *Locksley Hall Sixty Years After*, a recantation in some degree of the poet's early dreams of the progress of the world.

Alfred Tennyson has been one of the men whom the world has shown a growing delight to honor. His career affords a study in the concrete of the way in which all things are added to those who seek first that which is highest and best. In 1845 the value of his work and influence received recognition from the state in the award of a pension, and in 1850 in his appointment as Laureate. In 1855 the University of Oxford conferred upon him the decree of D. C. L. In 1865

he was elected Fellow of the Royal Society. The same year a baronetcy was offered him, which, however, he did not accept. The offer was repeated three years afterwards, and was again declined. In 1869 he was elected honorary fellow of his *alma mater*, Trinity College, Cambridge. In 1880 he was invited to stand for the Lord Rectorship of Glasgow University, but, the candidature involving his identifying himself with a political party, he declined the honor. In 1884 he was made president of the Incorporated Society of Authors. In the same year he was raised to the British peerage under the title Baron Tennyson of Aldworth and Farringford, a fitting and graceful recognition of his eminence in the world of thought and genius.

Concerning Tennyson's private life there is little to be said. For many of the years after leaving Cambridge he had no settled place of abode. Much of that time he lived in London with poverty and his golden dreams. His early married life was spent in Twickenham, which place he has made "twice classic." For upwards of thirty years he has lived at Farringford, Isle of Wight, and at his summer residence, Aldworth, in Surrey. Recluse as he has been, a few congenial spirits have found in him the prince of companions. Those who have been admitted to this charmed circle prize him as a man fully as much as they admire him as a poet. He is a penetrating judge of character, and knows instinctively, it is said, everything that is going on about him. He is fond of reading his poetry to appreciative listeners. His rendering is described as a mysterious incantation, exceedingly impressive, leaving the listener with the feeling that he has for the first time heard what he may have already read, perhaps, a hundred times. With his personal appearance the world has been familiarized by his numerous pictures. That the best of these, however, fail to do justice to the fine face is evident from the descriptions of those who have seen that face under the play of the passions within. Thomas Buchanan Read describes the poet's head as that of "a dilapidated Jove."

Of Tennyson and his work it is embarrassing to try to speak in general terms. The subject presents the double danger of falling into extravagance and yet of failing to do it justice. Disclaiming all attempt to adequately discuss it here, it may be remarked that Tennyson's poetry is pre-eminent for its beauty and for its power. On the first of these heads let the poetry speak for itself. Passing to the second, we characterize Tennyson's poetry pre-eminent in power because none of his contemporaries has touched so deeply and at so many points the hearts of the people of all ranks, classes, and conditions. Others have moved the masses; still others have been the pride of their own "restricted audiences." Not one, however, as this great minstrel, has so won the hearts of *all*. Is he, then, a "popular" poet? Yes; but not in the disparaging sense. Is he the apostle to the aristocracy? Yes; to the aristocracy of intelligence and virtue. Take up the collection of poetry—*Farnassus*—which shows the personal taste of that lofty intellectual aristocrat, Ralph Waldo Emerson; in it the greatest among other living poets are accorded but about quarter the space accorded to Tennyson; take up any modern "fireside" collection, the proportion will be found about the same. The wide influence of the poet is further shown by the *Complete Concordance* to his works, published in 1869; by the numerous translations his works have undergone into most of the languages of Europe, and by the willing aid which the kindred arts—music, sculpture, and painting—have lent to the illustration of his poetry.

In conclusion let us poll the jury of the poet's peers. Wordsworth: "He is decidedly the first of our living poets." Browning: "In poetry, illustrious and consummate; in friendship, noble and sincere." Mrs. Browning: "He is a divine poet; if anything were to happen to Tennyson the world should go into mourning." Swinburne: the high tributes already

quoted. Rossetti: "The greatest poet of the period." Thackeray: "The wisest man I know." Dickens: "What a great creature he is! . . . A great living poet, who uses his great gifts, as he holds them in trust, for the general welfare." Landor: "Infinite his tenderness, his thought, his imagination, the melody and softness as well as the strength and stateliness of his verses." Carlyle: "One of the few British and foreign figures who are and remain beautiful to me—a true human soul, or some approximation thereto, to whom your own soul can say, 'Brother!'" Gladstone: "His life and labors correspond in point of time as nearly as possible to my own, but his exertions have been on a higher plane of human action than my own. He has worked in a higher field, and his work will be more durable." Emerson: "Tennyson has incomparable felicity in all poetic forms. . . . Nay, some of his words are poems." Lowell: "It may be centuries before such a thinker and speaker as Tennyson appear." Stedman: "Certainly to be regarded in time to come, as, all in all, the fullest representative of the refined, speculative, complex Victorian age." That age has been widely deplored as grossly materialistic. Let those who can make of it nothing else or better ponder on the exaltation which has overtaken the humble youth

"That did love Beauty only." (C. E. W.)

TERHUNE, MARY VIRGINIA, novelist, better known by her pen-name, "Marion Harland," was born in 1835, in Amelia co., Va., her maiden name being Hawes. From her earliest years she was given to writing, and when she was 16 she had a story accepted for *Godley's Lady's Book*, which was translated into French, re-translated into an English periodical, and finally copied in America as an English tale. Encouraged by this singular success she determined to write a novel. This was published in 1854, under the title *Alone*, and at once created a sensation, while since that time upwards of 100,000 copies have been sold. In 1855 she produced *The Hidden Path*, which also had a large sale. In 1856 she was married to Rev. Edward P. Terhune, then a minister at Charlotte Court-House, Va. Marriage and its duties did not check her prolific pen. In 1857 her *Moss-Side* appeared, and this was followed in rapid succession by *Nemesis*, *Husks*, *Husbands and Homes*, *Sunnybank* and *Christmas Holly*, *Ruby's Husband*, *Phemie's Temptation*, *At Last*, *The Empty Heart*, *Jessamine*, *Handicapped*, *A Gallant Fight* (1888), eighteen novels in all, every one of a pure and elevating character. In 1858 Dr. Terhune was called to a church in Newark, N. J., where he and his family spent eighteen years. Two years were then devoted to travel and residence in Europe, which furnished material for a book called *Loiterings in Pleasant Paths*.

On his return Rev. Dr. Terhune received a call to the First Congregational Church of Springfield, Mass., and five years later to the Bedford Reformed Church, Brooklyn, N. Y., where he and his wife still reside, actively engaged in Christian and philanthropic work. Besides her novels "Marion Harland" has been noted for her counsel to housekeepers. Her *Common Sense in the Household* had an immediate success; 150,000 copies have been sold in America and half that number abroad, and it has been translated into Arabic, French, and German. Kindred works, constituting the Common Sense Series, have come from her pen, comprising *Breakfast, Luncheon and Tea*, *The Dinner Year Book*, *The Cottage Kitchen* (1883), and *Cookery for Beginners* (1885).

TERRAPIN. See TORTOISE.

TERRE HAUTE, a city of Indiana, seat of Vigo co., is on the left bank of the Wabash River, about 175 miles from St. Louis, Chicago, Cincinnati, and Louisville respectively. Nine railroads connect it with these and other places. The city is on a plateau 60 feet above the river, which is here crossed by three

bridges. It contains a U. S. government building, a handsome court-house, opera-house, 5 hotels, 3 national banks, 2 other banks, and 27 churches, some of which are fine structures. It has fourteen schools, whose property is valued at \$244,000; also the Indiana State Normal School, St. Mary's Institute, Coates College, Rose Polytechnic Institute, Rose Orphans' Home, and St. Anthony Hospital. Two daily and 4 weekly newspapers are published here. There are 7 foundries, 23 factories, and many mills, the total of industrial establishments being 125. The proximity of the block coal-mines of Clay county favors manufactures. The city has gas- and water-works and two parks. The property is valued at \$15,000,000; the public debt is \$283,000, and the yearly expenses about \$200,000. Terre Haute was settled by French colonists, an offshoot from Vincennes, Ind. Col. Francis Vigo (1740-1836), from whom the county was named, was a merchant here and advanced the funds for Gen. George Rogers Clarke's expedition against Kaskaskia. Terre Haute in 1880 had a population of 26,042.

TERRITORY. This article treats of the title of the United States to their territory and of the formation of territorial governments. The greater part of North America was claimed by the sovereign of Great Britain on the ground of its discovery by British subjects. The grant to Sir Walter Raleigh in 1584 of lands not held by any Christian prince or people and title to such as should be discovered under that authority resulted in no permanent establishment.

The first charter of Virginia, in 1606, granted the sea-coast of America from the 34th to the 45th degree of latitude to two companies termed the first and second colonies, the first colony to be established between the 34th and 41st degrees, and the second colony between the 38th and 45th degrees, but not less than 100 English miles apart. The western limit of this grant was indefinite. The second charter of Virginia, in 1609, defined more exactly the grant to and powers of the first colony, limiting it territorially to 200 miles north and the same distance south of Point Comfort, extending into the land from sea to sea. The third charter of Virginia, in 1611, was to the first colony and confirmed the terms of the second charter as it regarded the territory granted, but added that it should extend "from sea to sea, west and north-west," and also added certain islands. The first company, originally known as the London Company, organized under the second charter as the South Virginia Company. The second company was the Plymouth Company that settled New England.

The charter of New England, in 1620, was to the second colony under the Virginia grant, and its objects were to make the colonies independent of each other and to make partition of their territory between them, which had been partially accomplished by the second charter of Virginia. The territory granted under this charter was denominated New England, and was to extend from the 40th to the 48th degrees of latitude.

A charter was granted to the colony of Massachusetts Bay in 1629, embracing that part of the coast of New England between the Merrimac and Charles Rivers and extending beyond them respectively three English miles. This charter, intended to confirm a grant from Plymouth colony, was annulled in 1684 and a new charter granted in 1691. The last mentioned charter granted to Massachusetts Bay and Plymouth colony the Province of Maine and Nova Scotia and as far south as Rhode Island and Connecticut, including Cape Cod and westward to the South Sea.

Massachusetts was one of the original colonies and became a State at the Revolution.

New Hampshire was settled under grants from the Plymouth colony, confirmed by the crown in 1629, and became an independent colony in 1675 by royal decree, and became a State at the Revolution.

Rhode Island was settled under a patent of the Providence Plantations issued under the authority of

Parliament in 1643. It was chartered by the crown in 1663 and became a State at the Revolution.

Connecticut was settled and established as a government under commission from the General Court of Massachusetts in 1636 and asserted its independence in 1638. It was recognized as an independent colony by royal charter in 1662 and became a State at the Revolution.

Maine was constituted of territory of the Plymouth colony. In 1639 the Province of Maine was granted by the crown to Sir Ferdinando Gorges, as lands unoccupied under the New England grant, and in 1664 was granted to the Duke of York, together with land now occupied by the State of New York, which grant was confirmed in 1674. In the charter to Massachusetts Bay in 1691 Maine was confirmed to that colony, and in 1819 was made independent by an act of the Legislature of Massachusetts confirmed by popular vote. In 1820 an act of Massachusetts, confirmatory of her previous cession, consented to the admission of Maine as a State, and she was admitted in that year. The boundary of Maine where touching upon the British possessions was in dispute for many years, and was finally adjusted in the treaty with Great Britain of 1842.

Vermont.—The territory and jurisdiction of this colony were disputed between Vermont, claiming to be independent, and Massachusetts and New Hampshire, claiming in right of the Plymouth title, and New York in right of the Duke of York. These claims were finally relinquished, and Vermont was admitted as a State in 1791.

New York, which was originally settled in part and claimed by the Dutch, was, under a purchase made by the Duke of York from the Earl of Stirling, claimed by the Duke, who, in 1664, took forcible possession of New Amsterdam, and his title was finally confirmed by the second grant to him in 1674. New York was one of the original colonies and became a State at the Revolution.

New Jersey was originally settled by the Dutch, but was claimed by the Duke of York under his grant of 1664 and sold to Lord Berkeley and Sir George Carteret, the title of the duke being confirmed by the grant to him of 1674. New Jersey was an original colony and became a State at the Revolution.

Pennsylvania.—The territory of Pennsylvania, originally disputed between the Swedes, Dutch, and English, was finally granted to William Penn as unoccupied land in 1681, though the Swedes had already made settlements. Penn purchased of the Duke of York the territory of Delaware. Pennsylvania became a State at the Revolution.

Delaware was part of the territory of Pennsylvania purchased of the Duke of York, but was by charter from Penn allowed an independent government. Delaware was recognized as a colony and became a State at the Revolution.

Virginia.—The territory of Virginia, derived under charter to the first colony of Virginia, was reduced by her constitution in 1776 by the cession to Maryland, Pennsylvania, and North and South Carolina of their right of property and jurisdiction. Virginia became a State at the Revolution, claiming territory to the Mississippi, north of that relinquished to North Carolina and extending north indefinitely.

Maryland.—The territory of Maryland, although embraced in the grant to the first colony of Virginia, was, in 1632, granted to Lord Baltimore, and in 1776 relinquished by Virginia. Maryland was recognized as an independent colony and became a State at the Revolution.

West Virginia was formed of western counties of Virginia that did not follow that State in seceding from the Union, and was admitted as a State December 31, 1862.

Kentucky, originally part of Virginia, was claimed by the settlers to be independent, though such claim

was denied by Virginia. The constitution of Virginia of 1776 asserted jurisdiction over that territory, but such jurisdiction was not actually exercised. Virginia assented to a separate government for Kentucky in December, 1789, and by act of Congress in May, 1790, a temporary government was provided for such territory, designated as "south of the Ohio," and in 1790 Kentucky was admitted as a State.

Ohio was formed from the territory north-west of the Ohio that was ceded by an act of Virginia, passed in 1783, being part of the territory derived under the Virginia charters and granted by deed in 1784. At first, on behalf of France, and afterwards of Great Britain, a claim was made to this territory as part of the Province of Quebec, but this claim was extinguished by the treaty of peace with Great Britain in 1783. The North-west Territory, as ceded by Virginia, was organized by Congress in 1787. As this action tended to extinguish claims reserved to Virginia by the deed of cession, the ratification of that State was obtained in 1788. In 1800 Congress divided the North-west Territory into two parts, the easterly part embracing the territory of Ohio and part of that of Michigan, and erected the western part into Indiana Territory. In 1802 Ohio was admitted as a State with boundaries that excluded the territory embraced in Michigan.

Indiana was formed from Indiana Territory, which was divided in 1809, and the westerly part set apart and organized as Illinois Territory. Indiana was admitted as a State in 1816 with boundaries excluding the territory embraced in Michigan.

Illinois was formed from Illinois Territory, which had been set apart from Indiana Territory by act of 1809, from which it received separate territorial organization and was admitted as a State in 1818, with boundaries that excluded the territory embraced in Wisconsin and that west of the Mississippi.

Michigan, established as a Territory in 1805, embraced territory excluded by the northern boundaries of Ohio and Indiana, and in 1818 was extended to the Mississippi, and in 1834 to the Missouri River. Michigan had been claimed as part of the Province of Quebec. (See above under *Ohio*.) Michigan was admitted as a State in 1837 upon assenting to conditions fixed by Congress in 1836, excluding from its boundaries the territory west of the east line of Wisconsin.

Wisconsin.—In 1836, when Congress excluded from Michigan the territory west of Lake Michigan and a line connecting that lake with Lake Superior, it erected such excluded territory into the Territory of Wisconsin, extending to the Missouri and White Earth Rivers. In 1838 that part of the Wisconsin Territory west of the Mississippi was set apart and organized as the Territory of Iowa. Wisconsin was admitted as a State in 1846.

Minnesota.—The Territory of Minnesota was partly derived from the Virginia cession of the North-west Territory and partly under the Louisiana purchase. It was embraced in the Territory of Iowa, established in 1838 upon the division of Wisconsin Territory. It was organized as the Territory of Minnesota in 1849, excluding from its boundaries the Territory of Iowa and that of Dakota and admitted as a State in 1857.

North Carolina.—In 1663 a charter of the Province of Carolina was given, embracing part of the territory conveyed to the first Virginia colony, with boundaries that were extended by charter of 1665 so as to include from about latitude 36° 30' to Florida, and westerly to the South Sea. North Carolina, originally under the government of the Lords Proprietors, became independent as a colony and a State at the Revolution.

South Carolina, originally embraced in the Province of Carolina, received a separate government by the appointment by the Lords Proprietors of William Sayles as governor of that part of the Province of

Carolina south of Cape Carteret. The provincial assembly of South Carolina claimed independence of the Lords Proprietors in 1719. South Carolina became a State at the Revolution.

Georgia, originally part of the Province of Carolina, received a corporate government in 1732, with a cession of that part of South Carolina south of the Savannah River and extending west to the South Sea. A regular colonial government was given in 1752 and Georgia became a State at the Revolution. The constitution of that State in 1798 gave authority for the cession to the United States of the territory west of the Chattahoochee, and that cession was made. The territory thus relinquished was included in the Territory of Mississippi established in 1798 that extended to the Mississippi River.

Alabama was established as a Territory in 1817 out of the Territory of Mississippi, and was admitted as a State in 1819.

Mississippi, organized as a Territory in 1798, was admitted in 1817, comprising that portion of the territory excluded from the limits of Alabama. Portions of the States of Georgia, Alabama, and Mississippi were derived by the cession of the Floridas by Spain.

Tennessee was, upon its cession by North Carolina, embraced in the limits of the territorial government of the territory south of the Ohio, established in 1793, and remained in that condition after Kentucky, part of that territory, was a State. It was admitted as a State in 1796.

Louisiana occupies territory that was part of the Province of Louisiana held by France and ceded by France to the United States by treaty in 1803, during the administration of Pres. Jefferson, for which the United States paid \$11,250,000 in a 6 per cent. stock redeemable in annual payments of \$3,000,000, commencing in fifteen years from the treaty. Under an act of Congress in 1803 possession was taken of this province and its government committed for the time being to the President. In 1804 the province was divided into two Territories, that portion south of latitude 33° being named the Territory of Orleans, and the northerly part being called the District of Louisiana. The Territory of Orleans was organized in 1804 and the District of Louisiana provisionally attached to the Territory of Indiana. In 1805 the District of Louisiana was separately organized as the Territory of Louisiana. Louisiana was admitted as a State in 1811, embracing the Territory of Orleans.

Missouri.—The name of the Territory of Louisiana was in 1812 changed to that of Missouri Territory, and territorial organization completed. In 1820 Missouri was enabled to be admitted to the Union subject to the ratification of the boundaries assigned, and accepted such boundaries, excluding the north part of the Territory of Missouri and that embraced in Arkansas Territory.

Arkansas was organized in 1819 as Arkansas Territory out of that portion of Missouri Territory south of the territory of the present State of Missouri, and was admitted as a State in 1836.

Iowa originally formed part of Missouri Territory, but was separated from that Territory in 1834 and made part of Michigan Territory, and in 1836 embraced in the Territory of Wisconsin. In 1838 it was erected into the Territory of Iowa, and in 1845 was admitted as a State.

Florida.—The territory occupied by Florida was part of that ceded by Spain to the United States by treaty in 1819 under the name of the colonies of East and West Florida, and was organized as the Territory of Florida in 1822, and Florida was admitted as a State in 1845.

Texas was formerly part of the Republic of Mexico and united with Coahuila as a State of that republic. In 1833 Texas declared her independence, as a State of the Mexican Republic, and in 1835 framed a constitution. In 1836 Texas declared her entire inde-

pendence of Mexico and in the same year framed a constitution in conformity with such declaration. This independence was recognized by the United States and other nations. In 1845 Texas was annexed to the United States under a joint resolution of Congress accepted by that State, and in the same year was admitted into the Union.

Kansas.—The territory of Kansas was in part derived from Missouri Territory and in part under the cession of Florida in 1819, and was erected into the Territory of Kansas in 1854, the northerly portion extending to the Rocky Mountains. Kansas adopted a constitution in 1859 excluding the territory occupied by Colorado from its boundaries, and was admitted as a State.

Nebraska.—The Territory of Nebraska was organized in 1854 by the same act that organized the Territory of Kansas, and included with the territory of the present State a portion of that of Colorado, Montana, Dakota, and Wyoming, which were excluded from her boundaries at her admission as a State in 1867.

Colorado.—The territory occupied by Colorado was derived in part from the Territory of Nebraska and in part from that of Kansas, and was organized as the Territory of Colorado in 1861. Colorado was admitted as a State under an act of 1875.

California was occupied by military and naval forces of the United States during the Mexican war, and at its close, in 1848, passed by treaty into possession. It was admitted as a State in 1850.

New Mexico and *Utah* were organized as Territories in 1850 from lands derived from Mexico under the treaty of peace in 1848. New Mexico was enlarged by the Gadsden purchase from Mexico in 1853. *Nevada* was separated from Utah and made a Territory in 1861, and was admitted as a State in 1864. *Arizona* was separated from New Mexico and organized as a Territory in 1863.

Montana, *Wyoming*, and *Dakota* were, in 1854, embraced in the Territory of Kansas, that Territory being in part derived from the Louisiana purchase, in part through the treaty of peace with Mexico, and in part through the annexation of Texas. Montana was organized as a Territory in 1864, Dakota in 1861, and Wyoming in 1868.

Washington Territory was organized in 1853 of land derived under the treaty of 1846 with Great Britain for the settlement of the North-west boundary, and was originally established as the Territory of Oregon in 1846, and, upon the admission of Oregon as a State in 1859, received the residue of Oregon Territory not included in that State. *Idaho* was separated from the Territory of Washington and organized as a Territory in 1863.

The *Indian Territory* was acquired by the annexation of Texas, and was set apart for Indian occupation in 1828, under treaties with certain Indian tribes, and has not been organized as a Territory of the United States.

Alaska was acquired by purchase from the Russian government in 1867, and has not yet received complete territorial organization. After long remaining under military control, it was made a District in 1884, and has a governor appointed by the President.

The District of *Columbia* was ceded to the United States by Virginia and Maryland in 1791 as the national seat of government. Virginia's share was retroceded in 1846. From 1871 to 1874 the District had a territorial form of government, but this was revoked by Congress.

The authority possessed by Congress over the Territories is sovereign, and without other limitation than such as is imposed by the Constitution upon its powers at large. Article IV. of the Constitution declares that "Congress shall have power to dispose of and make rules and regulations respecting the territory or other property belonging to the United States." This power has been judicially defined as sovereign in its

nature. Although the Articles of Confederation are silent as to the authority of Congress over the Territories, yet the Congress under those articles in 1787 conferred territorial government on the "Territories north-west of the Ohio," which had been ceded to the Union by Virginia, and that authority was recognized and confirmed by the first Congress under the Constitution.

The authority of Congress to acquire territory from foreign states was seriously doubted by Mr. Jefferson, yet was exercised during his presidency in the purchase of Louisiana from France. The purchase of Florida from Spain and of Alaska from Russia, and the acquisition of the western part of the continent by the treaty of peace with Mexico at the close of the Mexican war, are instances showing the full recognition of the sovereign authority of Congress over the Territories of the United States.

The territorial government established in 1787 over the "Territory north-west of the Ohio" was a precedent and model that gave definition to the territorial policy of the United States. The form of government established in that Territory was substantially adopted in the succeeding organization of Territories down to the organization of Missouri Territory in 1812; it provided for the appointment of a governor, secretary, and judges of the Territory, with full legislative, executive, and judicial authority, subject to the Constitution and laws of the United States, but with a contingent provision for the creation of a legislative body when the population of the Territory should be such as to demand it. Another feature of the organic law of the "Territory north-west of the Ohio" which has exercised a large influence over the territorial policy was the proviso in that law that slavery should never exist in that Territory. This was intended as an organic provision that should enter into the constitutions and laws of all the States formed out of this Territory and form part of the organic law of such States, and that effect has been realized and its validity judicially recognized.

The organization of the Territory of Missouri under the act of 1812, while still retaining in the President of the United States the appointment of executive and judicial officers, provided for a legislative authority largely popular in its nature, but to some extent dependent upon the national authority. The legislative power was vested in a general assembly, that should consist of the governor, a legislative council, and a house of representatives. The house of representatives was filled by popular election, but the legislative council was selected by the President of the United States from a larger number of persons chosen by the representatives, and could be removed at the pleasure of the President. All laws were required to have not only the consent of the legislative council but that of the governor. All territorial laws depended for their efficacy upon their consistency with the Constitution and laws of the United States.

In 1816 the provisions of the organic act as to the choice of the legislative council were changed so as to make that body subject to popular election. The territorial act of Missouri contains a Bill of Rights similar to those generally introduced into the State constitutions.

Upon the admission of Missouri as a State of the Union the policy of excluding slavery from a portion of the Territories of the United States which was inaugurated by the act constituting the Territory North-west of the Ohio, was extended over the territory acquired from France under the name of Louisiana, which lay north of latitude 36° 30', and was intended as an organic provision that should extend to all Territories and States organized from that territory. (See SLAVERY.) (A. J. W.)

TERRY, ALFRED HOWE, major-general, was born at Hartford, Conn., Nov. 10, 1827. He was educated at Yale College, and was admitted to the bar in 1848.

He was made clerk of the New Haven county court in 1854, and was active in the militia. During the Crimean war he visited Europe in order to observe military operations, and at the outbreak of the American civil war he was probably better informed on such subjects than any other American outside of the regular army. The time came when his knowledge was to be reduced to practice. In 1861 he led his company to Washington, and at the battle of Bull Run he covered the retreat and saved a large amount of government property. He then raised the Seventh Connecticut regiment, and with it participated in Gen. T. W. Sherman's expedition to the Georgia coast. He was engaged in the siege of Fort Pulaski and afterwards had command of it and other forts. In March, 1862, he was commissioned brigadier-general and led a brigade at the battle of Pocotaligo. In 1863 he had command of a division and was engaged in operations in Charleston Harbor. He was afterwards with Gen. Butler's Army of the James and took part in the action at Drury's Bluff. From May till December, 1864, he commanded the Tenth Army Corps. In January, 1865, he commanded the land forces in the expedition against Fort Fisher, at the mouth of Cape Fear River. The fort was captured by assault Jan. 15, and from that date ran his commissions as major-general of volunteers and brigadier-general U. S. A. Gen. Terry marched inland and joined with Gen. Sherman in the closing events of the war. He afterwards had command.

TEWFIK PACHA, MOHAMMED, Khedive of Egypt, was born Nov. 10, 1852, at Cairo. He is the eldest son of Ismail Pacha, and when his father was compelled to abdicate, Aug. 8, 1879, he succeeded to the throne. The principal events of his reign have been narrated under Arabi Pacha (*q. v.*).

THANKSGIVING, in the United States, denotes an annual festival, not instituted to celebrate a single event, but to show proper gratitude to God for the blessings of the closing year. It was meant to gather up in thought all the mercies of a twelvemonth, all the bounties of the harvest, all the manifold gifts of Providence, and show a fitting recognition of the whole in gratitude which should overflow in festivity and mirth. As now observed, it may be said to be borrowed from the Jewish Feast of Tabernacles. The Hebrews, under the Mosaic law, celebrated the goodness of God in a harvest festival, under branches of trees and in tents of palm. They felt, beyond any other ancient people, that the fruits of the earth, the things needed for sustenance and comfort and cheer, were gifts of divine beneficence; and that it was fitting to express gratitude for them in a public celebration in which the gifts should be enjoyed. Thanksgiving day differs in these respects from the religious festivals, or holy days, that have prevailed in the various Christian churches. There have, however, been national and local festivals which have a closer resemblance. In Holland the anniversary of the deliverance of the city of Leyden from the siege, Oct. 3, 1575, was kept as a religious festival of thanksgiving and praise. In the English Church service the Fifth of November is celebrated in commemoration of the discovery of the Gunpowder Plot. The German Protestants, Lutheran and Reformed, have the custom of "Harvest Home," with religious services as well as general feasting and rejoicing. This custom was brought by German and Dutch immigrants into the United States. Hence probably came the local Thanksgiving day in parts of Long Island, after driving home for the winter the cattle which, during the most of the year, were pastured at Montauk Point.

But the American custom of Thanksgiving is historically traced beyond question to the earliest settlers of New England. In 1621, within a year after the landing of the Pilgrims at Plymouth, Gov. Bradford wrote as follows: "They began now to gather in the small harvest they had, and to fette up their houses

and dwellings against winter, being all well recovered in health and strength, and had all things in good plenty; for as some were thus employed in affairs abroad, others were exercised in fishing about codd, and bass, and other fish of which they took good store, of which every family had their portion. All the somer ther was no waste. And now began to come in store of foule, as winter approached, of which this place did abound when they came first (but afterwards decreased by degrees) and beside water foule ther was great store of wild turkies of which they took many, beside venison, etc. Beside they had about a peck of meal a weeke to a person, or now, since harvest, Indian corn to that proportion." In this connection Edward Winslow described the public commemoration in the following manner: "Our harvest being gotten in, our Governor (William Bradford) sent four men on fowling, so that we might after a special manner rejoice together after we had gathered the fruit of our labors. They four in one day killed as much fowl as, with a little help beside, served the company almost a week. At which time, amongst other recreation we exercised our arms, many of the Indians coming among us, and among the rest their greatest king Massasoit, with some 90 men, whom for three days we entertained and feasted; and they went out and killed 5 deer, which they brought to the plantation and bestowed on our Governor, and upon the Captain (Myles Standish) and others. And although it be not always so plentiful as it was at this time with us, yet by the goodness of God, we are so far from want that we often wish you partakers of our plenty." The next Thanksgiving day was in July, 1623. A long and severe drought had prevailed, and the governor appointed a day of fasting and prayer. During the prayer "soft, sweet, and moderate showers" fell, continuing for two weeks. The fasting and praying were changed into devout thanksgiving.

In the Plymouth colony Thanksgiving days were appointed for 1651, 1668, and 1680, and in the Massachusetts Bay colony similar observances were held in 1633, 1634, 1637, 1638, and 1639. The colony and province of New York was not without its days of praise and prayer. The Dutch governors proclaimed such days in 1644, 1645, 1655, and 1664. The English governors followed the example of their predecessors in 1760 and in 1775. Throughout the Revolution Congress annually recommended days of Thanksgiving. In 1784 there was a day of general praise for the return of peace and liberty to the country. In 1789 Pres. Washington appointed a day of rejoicing for the adoption of the Constitution. In 1795 he issued a call for a national thanksgiving; the preamble was this: "When we review the calamities that afflict so many other nations, the present condition of the United States affords much matter of consolation and satisfaction. Our exemption hitherto from foreign war; an increasing prospect of the continuance of that exemption—the great degree of internal tranquility we have enjoyed—the recent confirmation of that tranquility by the suppression of an insurrection which so wantonly threatened it—the happy course of our public affairs in general—the unexampled prosperity of all classes of our citizens—are circumstances which peculiarly mark our situation with indication of the divine beneficence toward us. In such a state of things it is in an especial manner our duty as a people, with reverence and affectionate gratitude, to acknowledge our many and great obligations to Almighty God, and to implore him to continue and confirm the blessings we experience." On account of these reasons the President recommended "to all religious societies and denominations and to all persons whomsoever, within the United States, to set apart and observe Thursday, the 19th day of February next, as a day of public thanksgiving and prayer, and on that day to meet together and render sincere and hearty thanks to the great Ruler of nations for the manifold and signal

mercies which distinguish our lot as a nation—particularly for the possession of constitutions of government which unite, and by their union establish, liberty with order; for the preservation of our peace, foreign and domestic; for the reasonable control which has been given to a spirit of disorder in the suppression of the late insurrection, and generally for the prosperous condition of our affairs, public and private; and at the same time, humbly and fervently to beseech the kind Author of these blessings graciously to prolong them to us; to imprint on our hearts a deep and solemn sense of our obligations to Him for them; to teach us rightly to estimate their immense value; to preserve us from the arrogance of prosperity and from hazarding the advantages we enjoy by delusive pursuits; to dispose us to merit the continuance of his favors by not abusing them, by our gratitude for them, and by a corresponding conduct as citizens and as men; to render this country more and more a propitious asylum for the unfortunate of other countries, to extend among us true and useful knowledge, to diffuse and establish habits of sobriety, order, morality, and piety, and finally to impart all the blessings we possess or ask for ourselves to the whole family of mankind." This proclamation followed the precedent by which Thursday had been uniformly designated by the governors of the New England States as the day of thanksgiving. In those States the Congregational Church predominated. In 1789 the Prayer-book of the Protestant Episcopal Church recognized the authority of the civil government to appoint such a feast. The custom went gradually to other States. In 1795 Gov. Jay, of New York, issued a proclamation of thanksgiving, which was but slightly attended to. A second trial was made by Gov. De Witt Clinton in 1817 and a hearty response was made. Since 1817 the annual Thanksgiving has been celebrated in the State of New York with hardly a break. The State of Pennsylvania followed soon afterward; but the Western States were more slow in adopting the custom. Illinois, admitted as a State in 1818, did not appoint a day of Thanksgiving until 1840, the day named being in December. The Southern States, owing to difference of climate and institutions, did not take kindly to the custom which had originated in New England; yet in 1858 the governors of eight Southern States sent forth proclamations for days of thanksgiving.

Until the great national crisis of the civil war, with the exception of Washington's administration, the custom was strictly confined to the will of the governors of the respective States. During the civil war Pres. Lincoln frequently appointed special days of thanksgiving for national victories; and more than once, when the results of great battles were discouraging to the Union cause, he appointed days of fasting and prayer. In 1863 he issued a long proclamation, appointing the last Thursday of November as a day of thanksgiving and prayer. The closing part of this document was in these words: "I recommend to the people of the United States that, while offering up the ascriptions justly due to God for such singular deliverances and blessings, they do also, with humble penitence for our national perverseness and disobedience, commend to his tender care all those who have become widows, orphans, mourners, or sufferers in the lamentable civil strife in which we are unavoidably engaged; and fervently implore the interposition of the Almighty hand to heal the wounds of the nation and to restore it, as soon as may be consistent with the divine purposes, to the full enjoyment of peace, harmony, tranquility, and union." Since that year every President of the United States has appointed the last Thursday of November as a national day of thanksgiving, and nearly all the governors of the States have followed with proclamations for their respective States. In the Protestant churches the religious observance of Thanksgiving is provided for by the several congregations and their ministers or other officers. Seldom

has any objection been made to the civil government appointing a day for religious worship, though some theologians, who have discussed the question, have insisted that the civil authorities can only recommend a day for the purpose, but cannot invade the religious rights of the people by enforcing its observance. This conclusion coincides with the view of the civil courts from the other side, and, indeed, with the general American idea of the relations of the state to religion.

In the Roman Catholic Church Thanksgiving day received no official attention until the Plenary Council met at Baltimore in 1885. It was then recommended that extra prayers be offered at the services on that day. Accordingly, in November, 1888, Cardinal Gibbons issued a circular, requesting the clergy of the archdiocese of Baltimore to honor the festival by reciting the prayers for the authorities of the State and nation after the late mass on that day. Similar directions were given by other prelates. This recognition will probably cause a still more general observance of Thanksgiving day, though American citizens of that faith had already in many instances shown regard for the festival.

Thanksgiving days, appointed by the national or State authorities, are a legal holiday in all the States of the Union. (See LEGAL HOLIDAYS.) (F. O. M.)

THAXTER, CELIA, poet, was born at Portsmouth, N. H., June 29, 1835. Since her fifth year she has lived on Appledore, one of the Isles of Shoals, about 9 miles off the coast. Her maiden-name was Leighton, and she was married at the age of sixteen. In 1867 she wrote for the *Atlantic Monthly* some essays on her island-home, which were gathered in a volume—*Among the Isles of Shoals* (1873). Her poems, collected from magazines and newspapers, are full of the charm and mystery of the sea.

THAYENDANEGEA. See BRANT, JOSEPH.

THAYER, SYLVANUS (1785–1872), called "Father of the Military Academy" at West Point, was born at Braintree, Mass., June 19, 1785. He graduated at Dartmouth College in 1807, and at West Point in 1808. He was employed in the construction of coast defences until 1812, when he was made chief-engineer of the Northern army for the invasion of Canada. In 1815 he was sent to Europe to examine the military schools, and on his return was made superintendent at West Point. The whole system of training there used was formed by Major Thayer. (See MILITARY ACADEMIES.) In 1833 he was employed in constructing forts in Boston harbor, and in 1838 became president of the Board of Engineers for coast defence. In 1843 he went to Europe for professional purposes, and after his return continued his work of coast defence until 1857, when he was relieved of duty, though not formally retired until 1863. He published some professional papers and gave liberally to the cause of education. Dartmouth College and his native town were among his beneficiaries.

THEATRE. See DRAMA.

THEOLOGICAL SEMINARIES IN THE UNITED STATES—During the colonial period, and in the early years of the republic, preparation for the ministry, as for the other professions, was obtained largely from private sources, according to location and opportunity. Harvard was designed as a seminary for preachers, and a chair of divinity was founded there in 1721. Theological classes were held at Yale from 1754. The few institutions of learning had this end more or less in view, for a far larger proportion of students became ministers than than now; but many sought instruction at home or from the nearest clergyman. The first Protestant theological school was initiated by the Associate Presbyterian Synod in Beaver co., Pa., in 1794, under John Anderson, D. D. The Associate Reformed Seminary, in New York city, was begun 1804 under John M. Mason, D. D. Andover, New Brunswick, and Princeton followed within the next eight years, and there are now over 150 institutions of

the kind, which may best be grouped here under the heads of the several religious denominations. The statistics are taken chiefly from the last report of the U. S. Commissioner of Education (for 1885–86), and many facts have been gathered from the *Schaff-Herzog Encyclopædia*. These schools represent every degree of strength, from a merely or nearly nominal existence to a long record of wide usefulness. Many of them stand on their own independent foundation; several of the greatest and some of the least are departments of universities or colleges. In the latter case the figures reported in a few instances appear to indicate the whole number of students in the college, not that in the theological department. The period of study in all the seminaries of higher character is 3 years, and the classes are usually called senior, middle, and junior. The States most extensively provided with these institutions will be found to be Pennsylvania and Illinois, each having 17; the denominations which claim the largest number of schools and instructors are the Roman Catholic and Baptist.

BAPTIST.

Hamilton Theological Seminary, located in the village of Hamilton, N. Y., was chartered 1819 and organized 1820. As the oldest Baptist seminary in America, it has been vitally identified with the history of the body for two-thirds of a century, and has furnished a large proportion of its ministers. It has a good endowment, 130 acres of land, three school buildings, and several residences. The successive presidents have been Drs. D. Hascall, N. Kendrick, J. S. Maginnis, G. W. Eaton, and E. Dodge. There are 6 chairs, 5 of which are now filled. Among their occupants have been Barnas Sears, T. J. Conant, A. C. Kendrick, and other eminent men. The seminary had at last accounts 54 students and 18,000 volumes in the library.

Newton Theological Institution, at Newton Centre, Mass., was organized 1825 and chartered 1826. The plan was to provide college graduates with a 3-years' course in divinity, beginning with the Hebrew and Greek Scriptures and giving prominence to Biblical studies. This limitation has been relaxed sufficiently to admit non-graduates who could follow the subjects pursued, and even to indulge a few with a 2-years' course in English alone. The institution was opened 1825, with Ira Chase, D. D., as sole teacher. H. J. Ripley, D. D., was appointed the next year; J. D. Knowles in 1834 (he died 1838); B. Sears, D. D., 1836, and H. B. Hackett, D. D., 1839. From that date there were 4 professors, to whom an instructor in Hebrew was added 1846. From 1868 there were 5 professors and a teacher of eloquence. There are now 8 instructors and 68 students. Alvah Hovey, D. D., LL. D., is president and professor of theology, H. Lincoln, D. D., professor of church history, and O. S. Stearns, D. D., of Old Testament Biblical interpretation. The library has 18,500 volumes. The endowment is over \$300,000, and the value of grounds and buildings about \$130,000. There are three halls, Colby, Farwell, and Sturtevant, with a gymnasium and 25 or more scholarships. Newton has sent forth full a thousand ministers, including some 70 foreign missionaries. It is governed by a board of 48 trustees, clerical and lay.

Shurtleff College, at Upper Alton, Ill., opened 1827 and chartered 1832, has a theological department under A. A. Kendrick, D. D., with 3 instructors, 13 students, and a library of some 7500 volumes.

Rochester Theological Seminary, at Rochester, N. Y., was chartered 1850 and opened 1851 with two professors. E. G. Robinson, D. D., LL. D., now president of Brown University, was long its leading spirit. Drs. T. J. Conant, H. B. Hackett, and A. C. Kendrick held chairs. A. Strong, D. D., has been president since 1872. There are now 10 instructors, among them Drs. Howard Osgood and W. A. Stevens, and

full a hundred students. The German department was founded in 1854. Near a thousand have entered from all parts of America, about one-fourth being Germans. The seminary has nearly \$500,000 of invested funds, and grounds and buildings valued at \$123,000. Trevor Hall was erected 1869 and Rockafeller Hall 1879. The library has over 21,000 volumes, and includes that of Neander. No subscription to creeds or formal statement of doctrine is here required, but any members of evangelical bodies are admitted on evidence of religious experience and a call to the ministry.

The Southern Baptist Theological Seminary was organized 1859 at Greenville, S. C., chartered 1876, and removed 1877 to Louisville, Ky. Its first endowment was destroyed by the civil war, and its operations suspended from 1862 to 1865, when it started again with 7 students. It has now some 114, with 6 teachers, real estate worth \$120,000, over \$200,000 of invested funds, and a library of 8500 volumes. The varying wants of students are met by a full theological course, one limited to the vernacular and elective studies; diplomas are given accordingly. J. P. Boyce, D. D., LL. D. (d. 1889), was chairman of the faculty and had been a professor since 1859. B. Manly, D. D., and J. A. Broadus, D. D., were also appointed at the opening of the seminary; C. H. Toy, D. D., 1869 (now of Harvard University); W. H. Whitsitt, D. D., 1872, and G. W. Riggan, 1881.

Wayland Seminary, founded 1865 at Washington, D. C., under the care of G. M. P. King, has real estate worth \$45,000 and a library of 2000 volumes. It reports 6 teachers and 126 students, but the number taking a theological course is probably much smaller, having been given a few years earlier as 3.

Shaw University, at Raleigh, N. C., organized 1865, chartered 1874, has a theological department under H. M. Tupper, D. D., with 2 instructors and 40 students.

Roger Williams University, at Nashville, Tenn. (formerly Nashville Normal and Theological Institute), opened 1865, reports a theological department under D. W. Phillips, D. D., with 2 instructors and 35 students.

The Baptist Union Theological Seminary, at Morgan Park, Ill., was opened in 1866, under the auspices of the Chicago Baptist Union, in the building of the Chicago University, by N. Colver, D. D., and J. C. C. Clark, who taught some 12 students there. A full organization was effected in October, 1867, with 20 students, under G. W. Northrup, D. D., as president and professor of systematic theology, and J. B. Jackson, D. D., as professor of church history. A building was erected in Chicago 1869. A Scandinavian department, under J. A. Edgren, began 1873 with 4 students; since increased to 28. The seminary was removed 1877 to Morgan Park, where it has 5 acres and a building worth \$50,000. A fair endowment was raised 1881 and subsequently. There are now 7 instructors, 90 students, and 18,000 volumes in the library. Dr. Northrup is still president.

The Atlanta Baptist Seminary, opened 1867 at Atlanta, Ga., is ruled by S. Graves, D. D., has real estate worth \$15,000, a library of 2500 volumes, and reports 5 teachers and 152 students, but not all in theology.

Richmond Theological Seminary (formerly Richmond Institute) was organized 1867 at Richmond, Va., and chartered 1876. C. H. Corey, D. D., is its head. It has 4 instructors, 50 students, a library of 3200 volumes, and real estate valued at \$20,000.

Crozer Theological Seminary, at Upland, Delaware co., Pa., was chartered 1867, and opened 1868 with 20 students. It now has 560 under 6 professors, H. G. Weston, D. D., being president from the start, a library of 9000 volumes, a lecture fund, and a fair endowment. There are two courses of study with differing diplomas.

William Jewell College, at Liberty, Mo., founded

1868, has, or had, a Jeremiah Vardeman School of Theology, pronounced by the commissioner of education "not a theological seminary proper."

The Benedict Institute, at Columbia, S. C., opened 1871, reports 6 teachers, 35 pupils, and a library of 1500 volumes. C. E. Becker is at its head.

Jackson College, opened 1877 at Jackson, Miss., has 6 teachers, 30 pupils, and real estate worth \$30,000. This is doubtfully placed among the theological seminaries.

Indian University, at Muskogee, Ind. Terr., founded 1880, has a theological department under A. C. Bacani, reporting 6 teachers, 70 students, and real estate worth \$28,000. These figures perhaps belong to the whole university.

The Selma University (formerly Alabama Baptist Normal and Theological Institute) was organized 1877, and opened 1878 at Selma, Ala. C. L. Pierce is at its head. It reports real estate worth \$15,000, with 7 teachers and 170 students, probably not all theological.

Bishop College, at Marshall, Tex., opened 1881, has a theological department under S. W. Culver, which reports 7 teachers and 166 pupils, with real estate valued at \$55,000. Here again the figures probably belong to the whole college.

Leland University, at New Orleans, La., has a theological department under H. R. Traver, with 3 instructors and 34 students.

Mercer University, at Macon, Ga., reports a theological department, with three students, under J. G. Ryal, D. D.

FREE-WILL BAPTISTS.

Hillsdale College, at Hillsdale, Mich., chartered 1852, opened 1855, has a theological department under G. F. Mosher, with 9 instructors, 53 students, and a library of 3000 volumes.

Bates College Theological Seminary, at Lewiston, Me., opened 1870, reports 4 teachers, 29 students, and 3000 volumes. O. B. Cheney, D. D., is at its head.

CHRISTIAN (*Disciples of Christ*, q. v.).

Eureka College, Eureka, Ill., chartered 1855, opened 1864, has a Bible department, with 3 teachers, 30 students, and a library of 2000 volumes.

Oskaloosa College, Oskaloosa, Ia., chartered 1856, opened 1872, has a Bible department, with 2 teachers, 13 students, and 2000 volumes.

The Christian Biblical Institute, at Standfordville, N. Y., opened 1869, reports 5 teachers, 11 pupils, 1900 volumes, and real estate worth \$40,000. J. B. Weston, D. D., is at its head.

The College of the Bible, at Lexington, Ky., chartered 1865, opened 1877, has 3 teachers and 100 pupils under R. Graham.

Drake University, Des Moines, Ia., opened 1881, has a Bible department, with 2 teachers, 48 students, and 1500 volumes.

CHRISTIAN (*Christian Connection*, q. v.).

Union Christian College, at Merom, Ind., opened 1862, has a "Berean department," with 2 teachers and 4 pupils.

A *Christian Biblical Institute* was begun at Eddytown, N. Y., 1869.

A *Literary and Theological Institute* for colored persons was opened at Franklinton, N. C., 1881.

CONGREGATIONAL.

Andover Theological Seminary, at Andover, Mass., was planned 1807, and intended to be connected with Phillips Academy, founded 1778. A junction was effected with another about to be established at Newbury, Mass., the "moderate" and "consistent" Calvinists uniting on the basis of a creed similar to the Westminster Catechisms. The seminary was incorporated as a branch of Phillips Academy under its trustees, but also under the supervision of a board of

visitors. It was opened Sept. 28, 1808, with a sermon by Pres. Dwight, of Yale. Thirty-six students entered at once. Dr. E. Pearson was the first professor of sacred literature, 1808-9; Dr. L. Woods of Christian theology, 1808-46; Dr. E. D. Griffin of sacred rhetoric, and Dr. Jas. Murdock of ecclesiastical history. Rev. Moses Stuart was professor of sacred literature, 1809-17, and was then succeeded by Dr. B. B. Edwards. Dr. E. Robinson was professor extraordinary in this branch 1830-33. Drs. E. Porter, R. Emerson, and T. H. Skinner were also in the faculty. Dr. E. A. Park was professor of sacred rhetoric 1836-47, and of theology 1847-81. Dr. A. Phelps succeeding to his former chair 1848-79; both these are now professors emeritus. In addition to the first 5 chairs, others of the relations of Christianity to science, of elocution, and of Biblical theology have been founded. There have been many gifts and benefactors. The buildings are 2 dormitories, 2 chapels, a library with over 45,000 volumes, a gymnasium, 8 houses for professors, etc. The real estate is valued at \$107,000; but it is not of material things that Andover is proud. During 80 years some 3000 students have been instructed here, and here the American Education Society, the Tract Society, the Temperance Society, and the oldest religious newspaper in America had their origin. The Andover Press has published the works of Profs. Porter, Woods, and Stuart, besides many commentaries, lexicons, etc. The *Bibliotheca Sacra* was printed here 1831-38, and the *Bibliotheca Sacra* founded 1844. The place has been a famous centre of religious learning and research. Andover theology professed to be a compromise between extreme Calvinism and Hopkinsianism, incorporating the substance of both. This is represented by the seminary "creed."

During the last few years an unfortunate controversy has threatened the credit and usefulness of this venerable institution. On Dr. Park's withdrawal in 1881 Dr. Newman Smyth was elected to his chair by the trustees. The Board of Visitors did not concur, and he was not installed. A question was afterwards raised and much mooted as to the orthodoxy of the faculty, in view of essays on "Progressive Orthodoxy" in the *Andover Review*, and especially of certain expressions as to the "last things." The chairs are now held by Drs. J. P. Gulliver, E. C. Smyth, W. J. Tucker, J. P. Taylor, J. W. Churchill, G. Harris, E. Y. Hineks, W. H. Ryder, and G. F. Moore. Drs. S. Harris, E. A. Lawrence, and E. B. Andrews are lecturers. The number of students for the year 1887-88 was 50; it is now larger. Dr. E. C. Smyth is president of the faculty. There are 2 fellowships and 30 scholarships. A fourth year is allowed for advanced study.

Bangor Theological Seminary was chartered 1814, and opened at Hampden, on the Penobscot (then in Massachusetts) October, 1816. In 1819 it was removed to Bangor. In 1820 the State of Maine was created, and the first class in this seminary graduated, numbering 6. The course was at first designed for such as had not gone through college and covered 4 years. The classical or preparatory department was abandoned in 1827, and the curriculum made to correspond with those of similar institutions, embracing 3 years of purely theological study. J. Ashmun, G. Shepard, and L. Woods, Jr., were among the professors. Dr. Enoch Pond (*q. v.*) was professor of theology 1832-56, and professor of ecclesiastical history 1856-70, also holding the presidency 1856-82. He was succeeded by L. L. Paine, D. D. There are now 5 professors, 30 students, with a library of 15,000 volumes, and real estate valued at \$65,000. Nearly 700 ministers have been sent forth with thorough theological preparation, and near 200 have received a partial training.

Yale College (now Yale University), New Haven, Conn., from its beginning in 1701-2 had a view to education for the ministry, and a professor of divinity

was the first appointed (1755) after the rector. Many of the most eminent clergy of America were trained here, as Edwards, Hopkins, Emmons, Bellamy, Dwight, Backus, Moses Stuart, N. W. Taylor, Lyman Beecher, Bennet Tyler, and E. Robinson. The theological school as a distinct department was established 1822, with N. W. Taylor, E. T. Fitch, and J. W. Gibbs as professors, to whom C. A. Goodrich was added 1839. The faculty now consists of Pres. Dwight and Dr. G. B. Day, Hebrew language and literature and Biblical theology (Old Testament); S. Harris, systematic theology; G. P. Fisher, ecclesiastical history; L. O. Brastow, homiletics and the pastoral charge; J. E. Russell, Biblical theology (New Testament); and G. B. Stevens, New Testament criticism and interpretation. There are also 3 instructors and 5 special lecturers. In 1886-87 there were 108 students, 10 of whom were pursuing graduate or fourth-year studies. The school has a reference library of 3000 volumes, and the library of church music of the late Dr. Lowell Mason.

The Theological Institute of Connecticut, otherwise Hartford Theological Seminary, was opened May 13, 1834, at East Windsor Hill, Conn., with Dr. Bennet Tyler as president. He led and formulated the severer New England theology, as against the liberalizing tendencies of Dr. N. W. Taylor, who was all-powerful at New Haven. Between these was much controversy, and their differences, then widely supposed to affect matters of faith, led to the formation of the Pastoral Union of Connecticut in 1833, and of its Theological Institute Dr. Tyler retained the presidency till 1857. The first professors with him were Drs. J. Cogswell, 1834-44, and W. Thompson, 1834-81. There are now 5 professors, 2 instructors, and some 40 students. In 1865 the institute removed to Hartford, where Hosmer Hall was erected 1879-80. The library contains 42,000 volumes. Near 600 ministers received their training at Hartford.

Oberlin Theological Seminary is a department of the college at Oberlin, O. In 1834 most of the students of Lane Seminary, at Cincinnati, withdrew because anti-slavery discussion was prohibited. They agreed to go to Oberlin if C. G. Finney (*q. v.*), of New York, would take the chair of theology there, and Arthur Tappan persuaded him to do so, and provided the means. Asa Mahan (*q. v.*) was elected president, and J. Morgan, of Lane Seminary, professor of New Testament literature. The seminary opened 1835 with 35 students. There are now over 400 alumni, mostly college graduates, and over 50 students in attendance. J. H. Fairchild, D. D., is president and professor of theology. There are 5 more professors and an instructor. These are not required to sign a creed, but the theology taught is new-school Calvinism of the Edwardean type. There is a good building, which cost some \$75,000, and a reference library of 2000 volumes.

The Chicago Theological Seminary was organized and chartered 1854, and opened Oct. 6, 1858, with 29 students and 2 professors, Drs. J. Haven and S. C. Bartlett. It now has 7 professors, 2 instructors, some 65 students, a library of 7500 volumes, and 2 halls facing Union Park, and worth \$127,000. There are two courses of English study and a German department; some 600 students have attended, and half as many graduated.

The Pacific Theological Seminary, at Oakland, Cal., was organized and chartered 1869. J. A. Benton, D. D., is senior professor. It has 3 teachers, 11 students, and 4000 volumes.

Fisk University, at Nashville, Tenn., organized 1869, has or had a theological course under E. M. Cravath.

Straight University, at New Orleans, La., chartered 1869, opened 1870, reports a theological department with 36 students under R. C. Hitchcock.

Talladega College, at Talladega, Ala., chartered 1869, opened 1872, has a theological department with 12 students under G. W. Andrews.

A German Congregational Theological Seminary, at Crete, Neb., opened 1878, has 15 students under W. Sims.

EPISCOPAL.

The General Theological Seminary in New York city was organized by the General Convention May 27, 1817, and opened May 1, 1819, in a room of St. Paul's Chapel, Drs. S. H. Turner and S. F. Jarvis being the first professors. It was removed to New Haven 1820, but brought back to New York in February, 1822, with 6 professors and 23 students, and chartered the same year. It is governed by a Board of Trustees elected by the General and Diocesan Conventions, each bishop being a member *ex officio*. Successive buildings were erected 1825, 1834, and 1883. Its finances have always been well managed, and it now has real estate worth \$600,000 and a library of some 19,000 volumes. Among its professors have been Bishops Brownell, Hobart, B. T. Onderdonk, Whittingham, and Seymour, Drs. Bird Wilson, Ogilby, Haight, S. R. Johnson, Mahan, S. Seabury, and F. Vinton, besides C. C. Moore, LL. D., and Hon. G. C. Verplanck. The faculty now consists of Drs. E. A. Hoffman, dean; W. E. Eigenbrodt, pastoral theology; S. Buel, systematic divinity; R. C. Hall, Hebrew and Greek; A. Oliver, Biblical learning and interpretation of Scripture; W. J. Seabury, ecclesiastical polity and law; T. Riehey, ecclesiastical history, and F. T. Russell, instructor in elocution. Several of these chairs have special endowments. An alumni professorship of evidences is not yet filled. There are 88 students. To the buildings on Chelsea Square (Sherred Hall, library and deanery) a chapel was added 1886-8.

The Protestant Episcopal Theological Seminary of Virginia was founded in Alexandria, Va., 1823, Dr. R. Keith being the first professor. In 1827 it was removed to a point over 2 miles west of Alexandria and 7 from Washington. It was not incorporated till 1854. Dr. W. Sparrow was professor of systematic divinity 1841-74. The chair of church history was filled by Drs. Lippitt, 1827-41, and J. May, 1841-61. It now has 6 professors and instructors, Dr. J. Packard being dean, with about 40 students, a library of 12,000 volumes, and several buildings. There is a preparatory department with a two-year course. It has sent forth some 800 ministers and 50 foreign missionaries, among them the late Dr. Hill of Athens. Bishops Payne of Cape Palmas in Africa, Boone of China, and Williams of Japan. Dr. Phillips Brooks of Boston is an alumnus.

The Theological Seminary of the Protestant Episcopal Church in the Diocese of Ohio, otherwise Bexley Hall, at Gambier, Ohio, was chartered 1824 and opened 1825. It has 5 instructors and a library of 7000 volumes, is under the management of Bishop Bedell, and is in relations with Gambier College. F. James, D. D., is senior professor.

Nashotah House, at Nashotah, Wis., opened 1841 and chartered 1847, has sent forth many Western clergy. It is controlled by 7 Western bishops, and has 20 students, a library of 9000 volumes, and real estate valued at \$100,000, but depends for its support on voluntary offerings. G. G. Carter is president, and Drs. W. Adams, J. M. Clarke, and T. M. Riley, professors.

The Berkeley Divinity School, at Middletown, Conn., was at first a department of Trinity College, Hartford, and as such graduated its first class in 1850. It was incorporated 1854 and removed to its present location, where it has a library of 17,000 volumes. Bishop Williams is president, and J. Binney, F. Gardiner, D. D., W. A. Johnson, S. Clarke, and F. T. Russell, professors.

Grinnell College, Davenport, Iowa, chartered 1859, has a small theological department (Lee Hall) under the direction of Bishop Perry. W. H. Barris, D. D., is dean, C. H. Seymour, professor, and C. R. Hale, D. D., instructor.

Seabury Divinity School, at Faribault, Minn., was opened 1860. It is controlled by Bishop Whipple, has 6 teachers, 25 students, a library of 6300 volumes, and real estate worth \$60,000.

The Divinity School of the Protestant Episcopal Church in Philadelphia was organized and chartered in 1862 while the seminary at Alexandria was closed by the war. An informal training-school had existed for some five years previous. An endowment was provided, a library of 8000 volumes, and a building in West Philadelphia, which was exchanged in 1882 for a larger one at Woodland avenue and Fiftieth street. E. T. Bartlett, D. D., is dean, and Drs. G. E. Hare, D. R. Goodwin, J. F. Garrison, and J. P. Peters, professors. There are now 26 students.

The Episcopal Theological School of Massachusetts was established at Cambridge, 1867, by a gift of \$100,000, and began with 4 professors and Dr. J. S. Stone as dean. He was succeeded by Dr. G. Z. Gray. It has a fine chapel and three halls, valued at \$325,000, but admission is limited to college graduates, and the number of students has never been large. There are now 16, under 6 professors, and about 100 alumni.

The Bishop Green Associate Mission and Training School, at Dry Grove, Miss., was opened 1867, and is in charge of W. K. Douglas, S. T. D.

St. Augustine's Normal School, at Raleigh, N. C., opened 1867 has a theological department and some property. It is under R. B. Sutton, D. D.

Matthew's Hall, at Denver, Col., opened 1872, is controlled by Bishop Spalding.

St. Andrew's Divinity School, at Syracuse, N. Y., was opened 1876.

The University of the South, at Sewanee, Tenn., chartered 1856, organized 1876, has a theological department, with 8 professors, 20 students, 2500 volumes, and buildings worth \$50,000. Telfair Hodgson, D. D., is dean. This is a live institution, which has made head against great difficulties.

The Kansas Theological School, at Topeka, Kan., began 1874, "has merely a nominal existence." A similar institution at Louisville, Ky., exists only in "a valuable library and productive funds."

Wheeler Hall, Chicago, Ill., was opened 1885 by Bishop McLaren. It has 5 professors, 12 students, 2000 volumes, and buildings on the Washington boulevard worth \$150,000.

EVANGELICAL ASSOCIATION.

Union Biblical Institute, at Naperville, Ill., was opened 1876, with 3 teachers and 8 pupils under J. J. Esher.

The German Evangelical Theological Seminary, opened 1850 at Normandy, Mo., was afterwards removed to St. Louis, and its name changed to Eden College. It reports 3 teachers and 90 pupils under L. F. Haerberle, with real estate worth \$120,000.

LUTHERAN.

Hartwick Seminary, founded 1815, in Otsego co., N. Y., has a small theological department, long conducted by G. B. Miller, D. D. A. Heller, D. D., is now at the head of it. A new building was erected about 1865, and a memorial volume published at Albany, 1867.

The Theological Seminary of the General Synod, at Gettysburg, Pa., was founded 1826 and chartered 1826. Its successive heads have been Drs. S. S. Schmucker, C. A. Hay, and M. Valentine. Dr. E. L. Hazelius became its second professor in 1830. Others were Drs. H. I. Smith, C. P. Krauth, Sr., C. F. Schaeffer, J. A. Brown, C. A. Stork, E. J. Wolf, and J. G. Morris. There are now 4 professors, about 40 students, a library of 11,000 volumes, 2 lectureships, an endowment of near \$100,000, and buildings worth \$75,000. The alumni number nearly 700.

The Theological Seminary of the Synod of Ohio, at Columbus, Ohio, was begun 1830. M. Loy, D. D., is

at its head, with 3 instructors, about 30 students, 4500 volumes, and real estate worth \$100,000.

The Theological Seminary of the South, at Newberry, S. C., opened 1830, has an endowment of \$22,000, 3 instructors, and a few students, under G. W. Holland.

Concordia Seminary, at St. Louis, was founded 1830 in Perry co., Mo., in a settlement of recent emigrants from Saxony. At first it included also a gymnasium or college, which was transferred to Fort Wayne, Ind., 1861. The seminary was removed to St. Louis in 1849, and passed in 1850 under the control of the Missouri Synod (afterwards the Synodical Conference). A fine building was erected 1882-3. Dr. C. F. W. Walther, long president, has been succeeded by F. Pieper. The seminary now has 6 professors and some 95 students, with a library of 5500 volumes. It has prepared near 600 men for the ministry. A branch of it, called a "Practical Seminary," was removed to Springfield, Ill., 1875, and now reports 5 teachers and 213 pupils.

Wittenberg College, at Springfield, Ohio, founded 1845, has a theological department in connection with the General Synod, which reports 2 teachers and 11 students.

Warburg Seminary, Mendota, Ill., opened 1856, is controlled by the German Synod of Iowa, and has 2 teachers and 50 students, with 3000 volumes. S. Fritschel, D. D., is its head.

The Missionary Institute, at Selinsgrove, Pa., opened 1858, is connected with the General Synod. It has a small property and endowment, 3000 volumes, 2 teachers and 12 pupils. P. Born, D. D., is at its head.

Augustana Seminary, at Rock Island, Ill., began 1860, belongs to the Swedish Augustana Synod, which is in communion with the General Council. It has real estate worth \$100,000, 2500 volumes, 3 instructors, and 48 students, under Dr. T. N. Hasselquist.

The Theological Seminary of the Evangelical Lutheran Church, at Philadelphia, opened Oct. 5, 1864, at 218 Franklin street, is controlled by the Ministerium of Pennsylvania and the General Council. It has maintained the ablest faculty and the highest character of any English Lutheran institution. Its first professors were Drs. C. F. Schaeffer, C. P. Krauth, Jr., W. J. Mann, and C. W. Schaeffer. The two first named died and were replaced by Drs. A. Spaeth and H. E. Jacobs. The library has 17,000 volumes. There are now 62 students and some 300 alumni. A collegiate education or its equivalent is necessary to entrance.

Augsburg Seminary, at Minneapolis, Minn., opened 1869, belongs to the Norwegian-Danish Conference. It has an endowment of \$46,000, 2 teachers, and 31 pupils. S. Sverdupe is at its head.

The Norwegian and Danish Augustana Seminary, at Beloit, Iowa, opened 1874, is controlled by the Norwegian Augustana Synod. D. Lysnes is its director.

Luther Seminary, at Madison, Wis., opened 1876, belongs to the Norwegian Synod, and has 20 pupils.

The Evangelical Lutheran Theological Seminary, at Milwaukee, Wis., begun 1878, is controlled by the Wisconsin Synod and the Synodical Conference. It has 3 teachers and 35 students.

The Red Wing Seminary, at Red Wing, Minn., is connected with Hauge's Norwegian Synod, and reports 5 teachers, 17 pupils, and real estate worth \$30,000.

A Practical and Theological Seminary, at Afton, Minn., opened 1884, belongs to the Joint Synod of Ohio.

Concordia College, at Conover, N. C., 1883, is directed by the Tennessee Synod and by P. C. Henkel, D. D.

Other small institutions of recent origin are reported as existing at Blair, Neb., Saginaw, Mich., Northfield, Minn., and Chicago. (See Stall's *Lutheran*

Year-Book, 1888, and *Lutheran Church Almanac*, 1888.)

METHODIST EPISCOPAL.

De Pano University (formerly Indiana Asbury University), founded 1837, has a theological department under A. Martin, D. D., LL. D., with 5 teachers and 45 students.

Boston University has a *school of theology*, which was projected 1837 and opened 1847 at Concord, N. H., as the Methodist General Biblical Institute. Among its early professors were Drs. J. Dempster, J. W. Merrill, O. C. Baker, S. M. Vail, C. Adams, and D. Patten. It was merged with the Boston University, 1871, endowed by the founders of that institution, reorganized, and removed to Boston 1876. It has a wide curriculum, with instruction in German and Spanish, and lectures by eminent divines of other bodies. There are now 13 instructors and some hundred students, with a library of 5000 volumes, and buildings valued at \$150,000. Dr. W. F. Warren is the president. Many missionaries have gone hence to Mexico and other lands.

Garrett Biblical Institute, at Evanston, Ill., was opened 1856 and chartered 1857. The first professors were Drs. J. Dempster, D. P. Kidder, and H. Banister, to whom were added Drs. M. Raymond and F. D. Hemenway. Dr. W. X. Ninde became president in 1879, and was succeeded by Dr. H. B. Ridgeway. There is a good building, and an endowment of some \$300,000. There are now 8 instructors, some 125 students, and nearly 500 graduates, besides many more who have taken a partial course. The institute is controlled by the Western conferences.

Wallace College (German), at Berea, Ohio, founded 1864, has a small theological department under W. Nast, D. D.

Central Tennessee College, at Nashville, opened 1866, has a theological department under J. Braden, D. D., and reports 9 teachers and 48 students.

The Gilbert Haven School of Theology in New Orleans University, La., opened 1866, reports 8 teachers, 20 pupils, and 3000 volumes in its library.

The Drew Theological Seminary, at Madison, N. J., was founded 1867 by a gift of \$250,000 from Daniel Drew. The Gibbons estate of about 100 acres, with a large mansion, was purchased, and 2 more buildings erected for students, with 2 for professors. The endowment was to have been doubled, but Mr. Drew's failure prevented. Pres. J. F. Hurst, however, procured subscriptions of \$300,000. The first president was Dr. J. McClintock, who died 1870. He was succeeded by Drs. Forster and Hurst, who became bishops, and Dr. H. A. Beatty, also professor of New Testament exegesis. The other professors are Drs. J. Strong, J. Miley, G. R. Crooks, and D. F. Upham. There are several instructors and lecturers, some 100 students, and a library of 18,000 volumes.

The Centenary Biblical Institute, at Baltimore, Md., on the corner of Fulton street and Edmonson avenue, was chartered 1867 and organized 1872. It has 11 teachers, 55 pupils, 1000 volumes, and real estate worth \$30,000. W. M. Fryinger, D. D., is at its head.

The German-English College, at Galena, Ill., opened 1868, chartered 1871, has a theological department under E. Uhl, with 2 teachers and 12 pupils.

A Swedish Theological Seminary, at Evanston, Ill., opened 1870, is taught by A. Ericson, and has 19 students, and real estate worth \$8000. A Norwegian and Danish theological school was opened here 1886 under N. E. Simonson, and is reported as a separate institution.

A German College, at Mount Pleasant, Iowa, was opened 1873, and has 4 teachers, 24 pupils, and real estate worth \$15,000. J. Schlagenhauf is at its head.

The Gammon School of Theology of Clark University, Atlanta, Ga., opened 1883, reports 3 teachers, 53

students, 4100 volumes, and real estate worth \$65,000. W. P. Thirkield, S. T. D., is dean.

McKendree College, at Lebanon, Ill., has a theological department with 10 students.

GERMAN METHODIST EPISCOPAL.—*Central Wesleyan College*, at Warrenton, Mo., opened 1864, has a theological department under H. A. Koch, D. D., with 4 teachers and 44 students.

METHODIST EPISCOPAL CHURCH, SOUTH.—*Trinity College*, at Trinity, N. C., has a theological department. The 8 teachers and 142 pupils reported doubtless include the whole college.

Vanderbilt University, Nashville, Tenn., founded 1872-75 with the finest endowment in the South, has a Biblical department, with 12 teachers and 45 students. W. F. Tillett, D. D., is dean.

AFRICAN METHODIST EPISCOPAL.—*Wilberforce University*, at Wilberforce, Ohio, opened 1853, has a theological seminary with 5 students under S. T. Mitchell.

AFRICAN METHODIST EPISCOPAL ZION.—*Livingston College*, Salisbury, N. C., has a theological department.

METHODIST PROTESTANT.

Adrian College, Mich., opened 1878, has a school of theology, with 3 teachers and 21 students under D. L. Stephens.

Westminster Theological Seminary, at Westminster, Md., opened 1882 under J. T. Ward, D. D., reports 5 teachers, 11 students, and a small library and property.

WESLEYAN METHODIST.—*Wheaton Theological Seminary*, at Wheaton, Ill., opened 1881 under L. N. Stratton, has 5 teachers and 16 students.

MORAVIAN.

The *Theological Seminary* was opened at Nazareth, Pa., Oct. 3, 1807, with 2 professors, E. L. Hazdus and J. C. Beckler, and 3 students, who in time became bishops. It was removed to Bethlehem, Pa., 1838, and has continued there, except for a sojourn of 7 years (1851-58) at Nazareth. It was incorporated 1863 as the Moravian College and Theological Seminary, with a course of 4 years in classics and 2 in theology. It has an endowment of \$80,000, a building worth \$9000, and a library of 5500 volumes. There are 25 students under Profs. A. Schultze (president), J. J. Hamilton, C. B. Shultz, and H. A. Jacobson.

PRESBYTERIAN.

Princeton Theological Seminary, at Princeton, N. J., was founded by the General Assembly in 1812. Dr. Archibald Alexander was at its head till 1851. Dr. Samuel Miller was professor, 1813-50; Charles Hodge (*q. v.*), 1822-78; J. Addison Alexander, 1835-60; John Breckinridge, 1836-38; J. W. Alexander, 1849-51; and A. T. McGill, 1854-83. Dr. W. H. Green was added to the faculty 1851; C. W. Hodge, 1860; J. C. Moffatt, 1861; C. A. Aiken, 1871; A. A. Hodge (*q. v.*), 1877; F. L. Patton (*q. v.*), 1880; and W. M. Paxton, 1883. Under these scholars Princeton has always been noted for the stern consistency of its Old School theology. It has instructed some 3700 students, and now has about 140 under 11 instructors. The library has 46,000 volumes. The seminary has received many benefactions from R. and J. Lenox, R. L. and A. Stuart, and others. It is exceptionally well supplied with funds and buildings. The *Biblical Repository* and *Princeton Review*, from 1825 to 1872, under the editorship of Dr. C. Hodge, represented the "Princeton School" and its theology. The *General Catalogue* of the seminary, by Dr. W. E. Schenck, 1882, covered 330 pages.

Union Theological Seminary, at Hampden-Sidney College, Va., existed in germ at an early period, and was reformed 1812 by the Synod of Virginia. In the next 8 years it sent out some 30 licentiates. Dr. Moses Hoge, president, died 1820, and in 1824 the Hanover Presbytery established the seminary as a separate institution. It passed under the care of the

General Assembly in 1826, and was henceforth governed, through 24 trustees, by the Synods of Virginia and North Carolina, receiving its present name. Dr. J. H. Rice was in charge, 1824-31; Dr. G. A. Baxter was president, 1832-41, and Dr. S. B. Wilson from 1841. By 1831 there were buildings, a library, and 3 professors; a fourth was added 1854. The seminary now has 5 teachers, 60 students, 12,400 volumes, 40 acres, with buildings worth \$50,000, and an endowment of \$250,000.

Auburn Theological Seminary, at Auburn, N. Y., was established by the Synod of Geneva 1819, and chartered April, 1820. Ten acres were given and a building erected; afterwards enlarged at a cost of \$40,000. In 1874-75 Morgan Hall was built, 216 by 45 feet, and 5 stories in height, costing \$100,000. The Dodge and Morgan Library cost \$40,000, has room for 60,000 volumes, and now has over 16,000. The seminary is governed by trustees and commissioners, representing the presbyteries included in the Synods of Albany, Geneva, Central New York, and Western New York. The doctrinal tone is in harmony with Princeton: "No leaven of Pelagianism or Arminianism has ever found its way into this school." Each professor on entering on his office signs a declaration of belief. There are 5 chairs, of Christian theology, church history and government, Biblical criticism, Hebrew language and literature, and sacred rhetoric and pastoral theology. Dr. S. M. Hopkins is senior professor; Dr. Willis J. Beecher is professor of Hebrew. There are about 50 students and 700 graduates.

The *Western Theological Seminary* was opened at Allegheny, Pa., Nov. 16, 1827, in accordance with action taken by the General Assembly in 1825. J. Stockton and E. P. Switt, D. D., were its first teachers. Eighteen acres of ground were granted. The first building, occupied 1831, was burned 1854, and another dedicated 1856. There are now 3 halls and 5 professors' houses, valued together at \$165,000. The library has some 21,000 volumes. The government is vested in 40 directors and a board of 30 trustees, the latter incorporated 1844. Each professor at his inauguration subscribes a pledge. They number 6, with some 70 students and over 1500 alumni, among them many missionaries. There is a post-graduate course.

The *Theological Seminary of the General Assembly* (South) was begun in 1828 and chartered 1832. At first under the care of the Synods of South Carolina and Georgia, with which that of Alabama joined in 1857, it was transferred in 1863 to the General Assembly of the Presbyterian Church in the Confederate States of America, which changed its name after the war. Among the professors were Drs. J. H. Thornwell (theology), 1855-62, and Howe (Hebrew), 1831-83. The seminary had in 1863 a good endowment, which was largely destroyed by the war, and not replaced till 1882, when the school, after being closed for 2 years, was reopened with 5 professors and some 25 students. Prof. Woodrow was suspended in 1886 on account of his showing favor to evolution. He was afterwards tried for heresy, but acquitted. The seminary was closed in 1886.

Lane Theological Seminary, at Cincinnati, Ohio, was begun as a preparatory school Nov. 18, 1829, 60 acres at Walnut Hills and a small sum of money having been given. The academy was abandoned in 1834 and the theological department opened in December, 1832, with Drs. Lyman Beecher and T. J. Biggs as professors. Dr. Calvin E. Stowe came in 1833 and Dr. B. Dickinson in 1835. An exodus of students occurred 1834. (See *Oberlin*.) Dr. D. H. Allen was professor of sacred rhetoric, 1840-51, and of systematic theology, 1851-67, when he was succeeded by H. A. Nelson, D. D. Dr. G. E. Day was professor of Biblical literature, 1851-66; Dr. T. E. Thomas of New Testament literature, 1871-75; Dr. H. Smith of sacred rhetoric, 1855-61 and 1865-79; and Dr. Z. M. Humphrey of church history, 1873-81. There are 5 professors and

about 40 students, a library of 13,000 volumes, a fair endowment, and good buildings. Near 800 graduates have gone into the ministry, mostly west of the Alleghenies.

Union Theological Seminary, New York city, was projected October, 1835, a board of directors chosen 1836, and a charter obtained March, 1839. Instruction was begun Dec. 5, 1836. A building on University Place was dedicated Dec. 12, 1838. Endowment came slowly, but now exceeds \$1,000,000, besides special funds. In 1884 a larger edifice, at 1200 Park avenue, was completed and occupied. The real estate is valued at \$700,000. Among the professors have been Drs. Edward Robinson, H. White, H. B. Smith, T. H. Skinner, William Adams, and Roswell D. Hitchcock. The faculty at present consists of Drs. W. G. T. Shedd, systematic theology; P. Schaff, church history; G. L. Prentiss, pastoral theology; C. A. Briggs, Hebrew; T. S. Hastings, sacred rhetoric; Francis Brown, Biblical philology; M. R. Vincent, sacred literature. There are also two instructors, a superintendent of mission work, a librarian, and three lectureships. In 1887-88 there were 132 students. The library began with that of Dr. L. Van Ess, purchased in Germany 1838, and now includes 55,000 volumes, besides many pamphlets and MSS. There are some 1500 alumni, among them over 130 foreign missionaries. The theology taught is of the New School type; the General Assembly has no control over the seminary beyond a veto (since the reunion in 1870) on the appointment of professors. A board of 28 directors, one-half laymen, govern the institution; they and the professors promise adherence to the Westminster Confession and to the Presbyterian form of government.

Danville Theological Seminary was opened 1853 at Danville, Ky. It has four professors, S. Yerkes being the senior professor, 11 students, 8000 volumes, and real estate worth \$10,000.

The *German Presbyterian Theological School of the North-west* at Dubuque, Iowa, was begun 1852, organized 1856, and chartered 1871. It has four professors, 28 students, 2000 volumes, and real estate worth \$25,000. A. J. Schlager, D. D., is chairman of the faculty.

The *McCormick Theological Seminary*, till lately the *Presbyterian Theological Seminary of the North-west*, is in Chicago, at 1060 N. Halsted street. It was chartered 1856 and opened 1859, and has recently received the stimulus of valuable benefactions. Its real estate is valued at \$200,000, and it has a library of 10,000 volumes. This is one of the most important theological schools of the West, with 11 instructors and 100 or more students. Dr. Le Roy J. Halsey is president.

Bible University, at Charlotte, N. C., for colored students, opened 1868, has a theological department with 11 students, under S. Mattoon, D. D.

Lincoln University, Pa., founded 1871 for colored students, reports a theological department under I. N. Rendall, D. D., with 8 teachers and 31 pupils.

The *German Theological School of Newark* was opened 1869 at Bloomfield, N. J., and chartered 1871. It reports 6 teachers and 28 students under C. E. Knox, D. D., with 3000 volumes and real estate worth some \$18,000.

San Francisco Theological Seminary, Cal., organized 1871, chartered 1876, has 16,000 volumes and real estate worth \$24,000, but very few students. T. Fraser is at its head.

An *Institute for Training Colored Ministers* was opened 1877 at Tuscaloosa, Ala. It reports 3 teachers and 19 pupils under C. A. Stillman, D. D.

UNITED PRESBYTERIAN.

The *U. P. Theological Seminary of Xenia, Ohio*, antedates almost all other existing theological schools in America, having been founded by the Associate Synod in 1794. It was long maintained at Canous-

burg, Pa., and was removed to Xenia in 1860, but not chartered till 1877. It has 4 teachers and 36 students under Dr. James Harper, with 4000 volumes and real estate worth \$15,000.

The *Theological Seminary of the U. P. Church*, at Allegheny City, Pa., was established 1825 and chartered 1868. It has 11 instructors, 36 students, 3100 volumes, and real estate valued at \$40,000.

The *Reformed Presbyterian Theological Seminary*, also at Allegheny City, Pa., opened 1856, has 3 teachers and 21 students, with 2800 volumes and real estate worth \$25,000. Dr. D. B. Willson is dean.

Another Reformed Presbyterian Theological Seminary is conducted in Philadelphia by Rev. David Steele, D. D.

CUMBERLAND PRESBYTERIAN.

The *Cumberland University at Lebanon, Tenn.*, chartered 1842, opened 1852, has a theological department, with 7 teachers, 27 students, 5000 volumes, and real estate worth \$10,000. N. Green, LL. D., is chancellor.

Trinity University at Tehuacana, Texas, opened 1871, has a theological department, but the 12 teachers and 300 students reported probably represent the entire college.

The *Associate Reformed Theological Seminary at Due West, S. C.*, opened 1840, reports 4 teachers and 6 students under Rev. W. M. Grier, D. D.

REFORMED CHURCH.

Dutch Reformed.—The venerable body, commonly distinguished as Dutch Reformed, wisely contents itself with a single theological seminary. The Dutch churches in America till 1771 were subject to the classis of Amsterdam, which then made it a condition of their independence that measures be speedily taken for theological education. Nothing was done till after the Revolution. In October, 1784, the Synod appointed J. H. Livingston, D. D., of New York, professor of theology, and H. Meyer, of Pompton, N. J., instructor in the "inspired languages." The former delivered an inaugural oration May 19, 1785, in New York, and began to receive students at his house; for a time he taught also at Flatbush, L. I. Synod appointed "lectors in theology," living elsewhere, with whom young men should study, that they might be examined and certified by Dr. Livingston. Two other professors at one time received students at their homes. By arrangement between the General Synod and the trustees of Queen's (now Rutgers) College, at New Brunswick, N. J., Dr. Livingston became its president, and removed thither 1810, having up to that time certified about 90 candidates. In 1812 the General Synod adopted a plan for the full organization and government of the school, and provided for the appointment of a board of superintendents. A second professor was appointed 1815, a third 1825, and a fourth 1865. Synod controls the seminary and elects its professors, who promise strict adherence to the Heidelberg Catechism, the Belgic Confession, and the canons of the Synod of Dort. The buildings are on grounds given by 3 patrons, and include 2 halls, a library, and 5 residences, in all valued at \$350,000. The seminary is well endowed; 2 benefactors together gave near half a million, and each endowed a chair. There are now 6 professors and 22 students; the library contains some 60,000 volumes. S. M. Woodbridge, D. D., is dean.

The *Western Seminary*, at Holland, Mich., opened 1866, has 3 teachers and 8 pupils under M. N. Steffens, D. D. This institution is the product of direct emigration from Holland.

GERMAN REFORMED.

The *Theological Seminary of the Reformed Church*, now at Lancaster, Pa., was opened March 11, 1825, at Carlisle, Pa., with 3 students and 1 professor. It was

removed to York 1829, and chartered 1831. In 1837 it moved to Mercersburg, the seat of Marshall College, where it developed the "Mercersburg Theology." In 1871 it followed the college to Lancaster. The professors of theology have been Drs. L. Mayer, J. W. Nevin (*q. v.*), B. C. Wolff, H. Harbaugh, and E. V. Gerhart. A chair of church history and exegesis, founded 1829, has been filled by D. Young, F. A. Rauch, and Drs. P. Schaff, E. E. Higbee, and T. G. Apple. A tutorship existed 1861-73. F. A. Gast took the new chair of Hebrew 1873. The seminary is controlled by three synods, through a board of trustees and one of visitors. It has a fair endowment (largely raised in Germany), a building worth \$20,000, a library of 10,000 volumes, 31 students, and 4 professors. Dr. E. V. Gerhart is at its head.

Heidelberg Theological Seminary, at Tiffin, Ohio, was established by the Ohio Synod and opened in May, 1851. Dr. E. V. Gerhart served alone till 1855, and was succeeded by Dr. M. Kieffer. The faculty now consists of Drs. J. H. Good (1869) and H. Rust (1861). There are 18 students, some 225 alumni, 3000 volumes, and an endowment of about \$30,000.

A *Mission House*, at Franklin, Wis., opened 1860, reports 7 teachers under H. A. Muehlmeier, D. D., and 4200 volumes. The number of students is not given.

Ursinus College, at Freeland, Pa., 30 miles northwest of Philadelphia, opened 1870, has a theological department, with 4 teachers, 10 students, and about 60 graduates. It was recognized by the General Synod in 1872. J. H. A. Bomberger, D. D., is president.

ROMAN CATHOLIC.

The *Theological Department of St. Sulpice and St. Mary's University*, Baltimore, Md., organized 1791, chartered 1860, has 8 teachers, 220 pupils, a library of 26,000 volumes, and real estate valued at \$150,000. A. Magnien, D. D., is at its head.

Theological Department of Mount St. Mary's College, Emmitsburg, Md., organized 1808; 27 teachers, pupils not reported; 10,000 volumes, real estate, \$150,000. E. P. Allen.

St. Vincent's Seminary, Germantown, Philadelphia, organized 1818; 6 teachers, 10,000 volumes. T. J. Smith.

Philadelphia Theological Seminary of St. Charles Borromeo, Overbrook, Pa., opened 1832, chartered 1838; 8 teachers, 106 pupils, 15,600 volumes. W. Kieran, D. D., vice-rector. This is one of the most important Roman Catholic institutions.

Augustinian Monastery of St. Thomas of Villanova, Villanova, Pa., organized 1842, chartered 1848; 8 teachers, 21 pupils in the "ecclesiastical department." T. C. Middleton, D. D.

St. Vincent's College and Theological Seminary, Cape Girardeau, Mo., chartered 1843, opened 1844; 10 teachers, 8000 vols. P. McHale.

St. Vincent's College, Beatty, Pa., opened 1846; 6 teachers, 37 pupils in theological course, 24,300 vols. D. Block.

St. Mary's Theological Seminary, Cleveland, Ohio, opened 1849; 5 teachers, 30 pupils, property valued at \$75,000. N. A. Moes.

St. Meinrad's Seminary, St. Meinrad's, Ind., opened 1854; 5 teachers, 8000 vols. F. Mundwiler.

Seminary of St. Francis of Sales, St. Francis, Wis., opened 1855, chartered 1877; 12 teachers, 110 pupils, 12,000 vols., real estate worth \$100,000. A. Zeininger, rector.

Diocesan Seminary of the Immaculate Conception, South Orange, N. J., opened 1856; 4 teachers, 15 pupils, 5200 vols. W. P. Sact, director.

College and Seminary of our Lady of Angels, Suspension Bridge, N. Y., opened 1856, chartered 1863; 7 teachers, 66 pupils. P. V. Kavanaugh.

St. John's University, Collegeville, Minn., formerly St. John's Seminary, St. Joseph, Minn., opened and

chartered 1857; 6 teachers, 22 pupils in "ecclesiastical course." A. Edelbrock.

St. Bonaventur's Seminary, Allegheny, N. Y., opened 1859; 8 teachers, 74 pupils, 6000 vols. T. Pospisilik.

St. Joseph's Provincial Seminary, Troy, N. Y., organized 1864; 7 teachers, 120 pupils, 9000 vols., real estate worth \$200,000. H. Gabriels, D. D. This ranks with or possibly above the seminary at Overbrook, Pa.

St. Charles Borromeo Theological Seminary, Carthage, Ohio, opened 1864; 19 teachers, 45 pupils. T. Wittmer.

Mt. St. Clement, Chester, Md., opened 1868; 11,000 vols., \$60,000 in real estate. E. Grimer.

Woodstock College, Woodstock, Md., chartered 1867, opened 1869. Conducted by Jesuit Fathers. No report.

Preston Park Theological Seminary, Louisville, Ky., opened 1870. No report.

Theological Department of St. Viator's College, Bourbonnais Grove, Ill.; 3 teachers, 29 pupils. M. J. Marsile.

College of the Sacred Heart, Vineland, N. J.; 7 teachers, 20 pupils. E. H. Porcile.

There are also said to be seminaries at Santa Barbara, Cal., and New Orleans, La., which made no report.

SWEDENBORGIAN OR NEW CHURCH.

Theological School, at Waltham, Mass., opened 1866. *Urbana University*, Urbana, Ohio, had in former years a theological department, but this is extinct.

UNITED BROTHERS IN CHRIST.

Union Biblical Seminary, Dayton, Ohio, organized and chartered 1871, has 4 teachers, 40 students, a library of 1100 volumes, an endowment of \$100,000, and \$25,000 in real estate. G. A. Funkhouser, D. D.

UNITARIAN.

The *Divinity School of Harvard University*, now professedly non-sectarian, made its mark and attained its reputation in the service of this body, and sent forth most of its ministers. Harvard College began in 1636 as a seminary for preachers, with a limited academical course. The first chair was that of divinity, endowed by T. Hollis, an English Baptist, 1721. The first chair endowed by a native of New England (T. Hancock) was that of Hebrew. The Divinity School began to have a separate existence in 1815, and was organized 1819. For near 60 years the chairs were occupied solely by Unitarians, among them many eminent men, as Drs. Ware, Norton, Peabody, Hedge, and Abbott. The graduates were a numerous body of the highest culture, and very many of them attained distinction. Of late no doctrinal restraints exist. Lectures have been delivered by a Trinitarian, and the appointment of an "orthodox" professor of dogmatic theology has been sought for years. There are now 6 professors, 21 students, 17,000 volumes, and real estate worth \$100,000. C. C. Everett, D. D., is dean of the school.

Meadville Theological School, Meadville, Pa., was founded 1844 by the Unitarians and the Christian Connection and chartered 1846. A belief in the divine origin of Christianity is the only doctrinal test. The successive presidents have been Drs. R. P. Stebbins, 1844-56; O. Stearns, 1856-63, and A. A. Livermore. Divinity Hall was erected 1854, and a fire-proof building holds a library of 18,000 volumes. The real estate is worth \$30,000 and the endowment is \$160,000. Two professors and an instructor are resident, and 3 give part of their time. There are about 30 students and 400 who have been such. A partial course is given besides the regular one of 3 years.

UNIVERSALIST.

Canton Theological School, Canton, N. Y., was organized and chartered 1858. It has 5 teachers, 14

students, a library of 7800 volumes, and real estate worth \$50,000. J. M. Atwood, D. D., is at its head.

Tufts College, at College Hill, Mass., has a Divinity School which was opened 1869, and made rapid progress. Drs. T. J. Sawyer and C. H. Leonard were the first professors. In 1875 a four-years' course was provided for non-graduates, and the faculty increased; it now numbers 7 professors and instructors. E. H. Capen, D. D., is president. There are 34 students and about 100 graduates.

Lombard University, Galesburg, Ill., has a theological department opened 1881. It reports 7 teachers and 11 students under N. White.

UNDENOMINATIONAL.

Howard University, at Washington, D. C., opened 1870, has a theological department under J. C. Craighead, with 5 teachers and 53 students.

JEWISH.

The *Hebrew Union College*, at Cincinnati, Ohio, was organized 1875. It has 6 teachers, 32 pupils, 9500 volumes, and real estate worth \$30,000. J. M. Wise is at its head.

From the above statistics it will appear that theological seminaries, no less than colleges, multiply beyond any very pressing demand for their services, or at least beyond the power and will to sustain them. It is a common remark that a moderate number of strong institutions would be better than a plethora of feeble ones. But the American tendency is to bring education, professional as well as general, as near as possible to every man's door, and in the strife of sects each wishes to be represented, as nearly as it can, in every part of the country. The moral is obvious, but is usually unheeded. With several of the denominations one-third or more of their schools might be wiped out without special injury, and this process is not unlikely to take place to some extent. (F. M. N.)

THERMOMETER. This familiar instrument for determining the temperature of air or other fluid is usually filled with mercury; but many thermometers for special uses are filled with colored alcohol. The mercury or alcohol is contained in a glass ball from one side of which arises a long and thin hollow tube with a very small bore, and the ball and tube are fastened upon a flat piece of metal or wood upon which are marked various degrees. The uniformity of the bore is tested by introducing a small quantity of mercury and moving it along the tube from end to end by air forced out of a small india-rubber ball attached to one extremity. If the column is observed to occupy the same space throughout the bore is considered to be of uniform diameter. This process is called the calibration of the tube. The ball, or bulb, and part of the tube are filled with mercury that has been strained through chamois leather. In the usual process of filling thermometers a lamp is held to the bulb until the air is highly rarefied; the end of the tube is then placed in a vessel of mercury, the lamp removed, and the mercury rises in the tube by the cooling and condensing of the air in the bulb. The bulb is then held downward and the mercury heated so that, in expanding, it entirely fills the tube. Then the top of the glass tube is sealed with a blow-pipe; and the mercury, contracting as it cools, falls down in the tube toward the bulb, leaving above it a vacuum. Upon the application of heat to the bulb the mercury expands and rises in the tube in proportion; or it shrinks and drops in the tube as it cools. Besides the bulb and the tube it is necessary to have a graduated scale in order to make the instrument of practical service. The three principal scales in use are Fahrenheit's, Reaumur's, and the Centigrade. The scale used for ordinary purposes, both in England and the United States, is Fahrenheit's, although both this and Reaumur's are sometimes marked on the same in-

strument. Fahrenheit's scale is formed thus: The bulb of the thermometer is placed in boiling water, and the height to which the mercury rises is marked by a scratch on the tube; it is then put into melting snow or ice, and another scratch is made at the point where the mercury has descended. The space between these two marks is divided into 180 equal parts, called degrees, and these divisions are carried upward to nearly the end of the tube, and downward toward the bulb; the upper scratch, indicating the heat of boiling water, is marked 212, and the lower one, the freezing point of water, is 32. The zero point was intended to mark the temperature of a mixture of snow and salt, which was supposed to be the utmost possible natural cold. On the scale of Reaumur's thermometer the zero is at the freezing point of water, and the boiling point is marked 80. The Centigrade differs from Reaumur's only in having the space between the boiling and freezing point of water divided into 100 parts instead of 80. The "register thermometer," or "maximum and minimum thermometer," has two bulbs, tubes, and scales on the same instrument; one bulb is filled with mercury and the other with colored spirit. In each tube a piece of enamel, about half an inch long and fitting the cavity, is introduced; the one in the mercury is to register the highest, and that in the spirit to register the lowest, degree of heat. They act in the following manner: The spirit, when rising in the tube, wets the enamel and passes by it so that the elevation of temperature does not affect its position, but when the spirit sinks it carries the enamel with it, thus registering the lowest temperature, so that the distance the enamel is found down the tube indicates how low the spirit may have descended in any particular time, say a night. Mercury, on the other hand, does not adhere to the enamel, and therefore, on rising, pushes it up in the tube, but on descending leaves it behind, the height at which the enamel is found up the tube indicating the highest point to which the mercury had risen, and consequently the highest temperature. To adjust the instrument, a slight tap or shake will make the index in the spirit-tube rise to the surface of the spirit, where it is held by the adhesive quality of the liquid, and by the same process that, in the mercurial tube, will fall to the surface, but will not penetrate the mercury, owing to its great density.

In making very accurate thermometers the boiling point is found by immersing the instrument in steam and not in the water itself, as water really boils at different temperatures depending upon various circumstances, whilst the temperature of the steam is uniform. Even with the greatest care in constructing, the indications of a thermometer are liable to derangement; and this result may come more particularly from the bulb not resuming its former capacity after being heated to a high temperature. Such a fault as this may not be discovered until comparison has been made with thoroughly reliable thermometers.

Aside from the thermometer certain appliances must be used to assist in case of finding temperature in inaccessible places, like the different depths of the sea, etc. Siemens has invented a method of ascertaining the temperature at such depths, depending on the principle that the electric resistance of metals is in proportion to the increase of their temperature. The process requires two coils of the same kind of platinum wire which shall have equal resistance. The ends of the wires are connected with long and thick copper wires; so that, if necessary, the coils may be placed at a considerable distance from the galvanometer. The copper terminals are adjusted so that each coil shall have the same resistance; but such resistance should be small in comparison with the resistance of the coils themselves. One of the coils is sunk to the required depth in the sea, and the other is placed in a jar of water on the deck of the ship. The temperature of the water in the jar is adjusted until the

resistance of both coils is the same. Thus, the temperature of the water in the jar is made the same as that of the sea-water at the depth of the lower coil. The thermometer showing the temperature of the water in the jar will, therefore, show the temperature of the water at the depth required.

For the mutual conversion of the three standard thermometric scales, Fahrenheit's, Reaumur's, and the Centigrade, the following formulæ are convenient: $F : C : R :: 180 : 100 : 80 = 9 : 5 : 4$. Therefore, $F = \frac{9}{5}C$; $F = \frac{9}{4}R$; $C = \frac{4}{5}R$. Of course to convert F. degrees into C. or R. degrees 32 must be subtracted before (and in the converse problem added after) either of the first two formulæ is applied. (F. G. M.)

THESSALONIANS, EPISTLE TO. See ROMANS, EPISTLE TO.

THISTLE is the common name given to several genera of *Compositæ*. The thistles See Vol. XXIII. of the United States chiefly belong to p. 306 (p. 327 the genus *Cirsium*, of which we have Am. Rep.). about 20 species. They are distinguished by perfect and similar flowers, of tubular form and grouped in many-flowered heads. They have bristly receptacles, corollas of purple or reddish color, oblong smooth achenia, and a plumose pappus. Most of the thistles are useless and troublesome weeds, one of our introduced species being among the worst pests of agriculturists. This is the Canada thistle (*C. arvense*), which has extended throughout the United States and over the agricultural districts of Canada. It is a low, branching plant, with extensively creeping roots; affects cultivated fields and pastures, and is extremely difficult to eradicate. It can be got rid of only by plowing and persistent extraction of the roots. The most common of our thistles, *C. lanceolatum*, is also an introduction from Europe. It is found in over-abundance on road-sides and in thick pastures, has very prickly stem leaves, and bears numerous handsome purplish flowers. The common yellow swamp-thistle extends from Massachusetts to the South, where there is another yellow thistle, *C. horridulum*, a tall, rough, disagreeable sea-coast plant, well named the horrid thistle. Of species of other genera may be named *Onopordon acanthium*, the cotton thistle, a tall, showy plant, with large light-purple flowers; and *Centaurea americana*, a handsome species of the South-western States, which is cultivated in gardens. Many plants are called thistles which belong to quite different families from the typical thistles. (C. M.)

THOMAS, GEORGE HENRY (1816-1876), one of the most illustrious generals of the American civil war, was born in Southampton co., Va., July 31, 1816. His father's family, originally Welsh, had by long residence become English before emigrating to America; his mother was of Huguenot extraction. When a boy Thomas learned by watching workmen to make a saddle, boots, and furniture and thus cultivated habits of observation and combination that stood him in good stead in his future career. The first twenty years of his life were spent at home and in attendance at Southampton Academy. On leaving school he entered the office of his maternal uncle, James Rochelle, county clerk, but on being offered a cadetship in West Point he gladly gave up law for arms. He entered the academy in June, 1836, and in 1840 graduated twelfth in a class of 42, and was commissioned second-lieutenant in the Third artillery. His company was ordered to Florida, and there he remained till the termination of the Seminole war. In 1841 he took part in the capture of 70 Seminole Indians, and was brevetted first-lieutenant "for gallantry and good conduct in the war." In 1844 he was promoted to first-lieutenant and joined his company at Fort Moultrie. His next service was in Mexico under Gen. Taylor, where he was brevetted captain "for gallant and meritorious conduct" in the battles about Monterey, and major for his conduct in the battle of Buena Vista. In

1847 the citizens of his native county, proud of his achievements, presented him with a sword. In 1851 he was assigned as instructor of artillery and cavalry at West Point, and while there married, in 1852, Miss Frances S. Kellogg, Troy, N. Y.; receiving his promotion to a captaincy September, 1853. In 1855 he was appointed major of the Second cavalry and, in the following year, went with his new regiment to Texas where he remained till 1860. During this time he accompanied an expedition to the Canadian and Red Rivers, and another to the Conchas River, Mexico, where he received his only wound from a band of predatory Indians. An arrow which had transfixed his chin and penetrated his breast he drew out with his own hand. In 1860 while he was on his way home on leave of absence his spine was injured in a railroad accident, and to this has been attributed his slow riding and deliberate movements so much commented on during the war. In 1861 he applied for the position of instructor of cadets in Lexington Military Institute, Va., and this application, though unsuccessful, roused a suspicion of his loyalty that tended afterwards to impede his well-merited promotion. When the Legislature of his native State in April, 1861, voted for secession, Major Thomas remained faithful to the Union, and his first service in the civil war was, on April 21, to aid in quelling a secession mob in Maryland.

Vacancies occurring rapidly through resignation, on April 25 he was promoted to the lieutenant-colonelcy, and on May 5 to the colonelcy of his regiment, now known as the Fifth cavalry. The first service rendered by the new colonel was under Gen. Patterson against "Stonewall" Jackson at Falling Waters. When Patterson's failure to hold Gen. Jos. E. Johnston subjected him to obloquy, Col. Thomas spoke out loyally in his behalf. In August, 1861, he was appointed brigadier-general of volunteers and was assigned to the command of Fort Dick Robinson, Ky., where he found 6000 raw troops. While in Washington, Thomas had suggested the occupation of Tennessee and the seizure of the railroad connecting Richmond with the South-west, and was mortified to learn, while increasing and organizing his force with this view, that his plan had been accepted but its execution given to Gen. O. M. Mitchel. His own immediate duty was to resist the advance of the Confederates, who under General Zollicoffer had invaded Kentucky by way of Cumberland Gap (*q. v.*). A force sent out by Thomas drove the enemy back into the Gap, immediately on which he began preparations for invading East Tennessee, when an order from Gen. D. C. Buell, now commanding the department, required him to move his whole command to Lebanon, Ky. Here Thomas organized the first division of the Army of the Cumberland, whence he threw out reinforcements to Gen. A. Schoepf to aid him in preventing Zollicoffer crossing the Cumberland. In spite of opposition Zollicoffer with 8000 men crossed the river, and intrenched himself opposite Mill Spring. Thomas's whole force took the field on the last day of the year, and, after a laborious march of 19 days, reached Logan Cross-Roads, 10 miles south of Mill Spring, where he halted for the arrival of Schoepf with whom he was to make a conjoint attack on the enemy's position. He was, however, forestalled by Zollicoffer, who, anticipating an easy victory, left his lines and on Jan. 19 made an attack on Thomas' camp, driving in his pickets. Thomas rapidly formed his line and by a brilliant charge forced the enemy back to their intrenchments. Being joined by Schoepf, preparations were made for an assault on the intrenchments on the 20th, but during the night Zollicoffer crossed the river and escaped, leaving his artillery and supplies to the victor. By this action—the first Union victory in Tennessee—10,000 men were eliminated from the operations that followed.

The capture of Forts Henry and Donelson compelled the evacuation by the Confederates under Gen. A.

Sydney Johnston and Beauregard of Columbus, Bowling Green, and Nashville, and Gen. Thomas was ordered to report at the last place, where he remained as Buell's reserve till April. After the battle of Shiloh he joined the main army under Gen. H. W. Halleck—who now left his head-quarters at St. Louis—in its advance on Corinth. Halleck, who was not quite satisfied with Grant's management at Shiloh, appointed him second in command, thus relieving him of the command of the Army of the Tennessee which he conferred on Thomas. At Corinth, Thomas, learning that Grant felt hurt, asked to be relieved from the Army of the Tennessee, and restored to his old command in the Army of the Cumberland, which reduced him from the leadership of five divisions to that of one. On June 10 the transfer was effected and he joined Buell at Nashville, being put in command of the post while Buell started for Kentucky to check Bragg. In September he joined Buell at Cave City and was placed second in command, holding this position during Bragg's invasion and till Buell's withdrawal to Louisville. Here an order came from Washington relieving Buell of the command and conferring it on Thomas, but the latter again generously declined the promotion, on the ground that it was unjust to relieve a commander on the eve of a battle for which he had made preparation, his force having been augmented to 100,000. On Oct. 7 the army moved out of Louisville with Thomas in command of the right wing. On the 8th the battle of Perryville was fought, principally by the left wing under McCook, the right, from its position, being unable to take part except with its cavalry as skirmishers. The action was sanguinary, and the enemy retired across the Cumberland toward Murfreesboro; but there was no effective pursuit.

The dissatisfaction at Washington with the results of this battle led to the nomination of Rosecrans to supersede Buell. Thomas felt himself aggrieved by the appointment, and protested against it as subordinating him to a junior, but without avail. Rosecrans offered to continue him as second, but he preferred a distinct position and was assigned to the command of the centre, composed of four divisions. The entire force now marched to the vicinity of Nashville. In the advance against Bragg at Murfreesboro, begun on Dec. 26, Thomas marched with only two divisions—Rousseau's and Negley's—and two detached brigades, the troops left to maintain communication with Louisville having been withdrawn from him. At the battle of Stone River (*q. v.*), on Dec. 31, Thomas through the exhibition of his pre-eminent qualities of calm resolution, self-reliance, and immovable firmness, saved the day from being a Union defeat. When his supports were driven back in confusion he alone held the enemy at bay, changing his front and shifting his position in face of a victorious foe, and thus enabling Rosecrans to form that second line that, next morning, struck the enemy with amazement. But for Thomas the Union army would have been withdrawn to Nashville. At the council held late at night Gen. Thomas fell sound asleep. When it was decided to withdraw, and Rosecrans awoke him with the question: "Will you protect our retreat?" he simply answered: "This army can't retreat," and fell asleep again. It was Thomas who, on Jan. 2, mainly baffled Breckinridge's assaults, and who ultimately drove Bragg out of Murfreesboro.

For six months after this battle Rosecrans lay at Murfreesboro. In the series of brilliant strategic movements which began in the latter end of June, and which resulted in the Confederates evacuating Chattanooga, Thomas bore a distinguished part. But it was at Chickamauga (*q. v.*) that he earned the title that so aptly characterized him—"The Rock of Chickamauga." On the first day it was mainly by his corps that the enemy's onslaughts were repulsed. During the night Bragg was reinforced by Longstreet, and next day the assaults were renewed with redoubled

vigor in the hope of piercing the Union lines. At length the supports on Thomas' flanks were broken, and McCook's and Crittenden's corps routed, streaming in such confusion to Chattanooga that Rosecrans believed himself defeated and so telegraphed. But Thomas stood unshaken, and here, as at Murfreesboro, saved a lost battle to the Union. Wheeling his lines within the defile of Frick's Gap, whose steep sides protected both his flanks, he grandly withstood all onsets till the baffled enemy ceased his efforts. Garfield, chief of Rosecrans' staff, hearing the noise of continued fighting, halted in his flight, and rode back to the scene of conflict. "Never," says he, "will I forget my amazement and admiration when I beheld that grand officer holding his own, with defeat on every side." During the night he led his corps back to the lines of Rossville, and next evening conducted it in perfect order to Chattanooga. Rosecrans made no overstatement when he wrote: "To Thomas, the true soldier, the prudent and undaunted commander, the modest, uncorruptible patriot, the thanks of the country are due for his conduct at the battle of Chickamauga."

On Oct. 19 Rosecrans was relieved of his command. Thomas was most justly appointed his successor, and, on the 27th, made brigadier-general of the regular army. On assuming command he at once addressed himself to strengthening the fortifications of Chattanooga and securing supplies, as well as to making preparations for the advance planned by Gen. Grant, who had taken command of the entire Division of the Mississippi. On Nov. 4, by a bold dash, he made himself master of the enemy's works at Orchard Knob, commanding part of the fortifications on Missionary Ridge, and on the next day his Fourth corps, under Gen. Joseph Hooker, made its great charge up the steep side of the hill, swept across it, and broke the Confederate centre. The battle of Missionary Ridge was won; Bragg was in full flight; the Union arms held the key of the central regions.

Gen. Thomas had now a long period of rest. When Grant was promoted to be lieutenant-general the command of the Military Division of the Mississippi devolved on Gen. Sherman, and Thomas was placed under him. Though thus made subordinate to his junior, he was too patriotic to show offence, and promptly yielded him obedience.

On May 7, 1864, Sherman put his legions in motion against Gen. Joseph E. Johnston on their famed march on Atlanta, and Thomas' old Army of the Cumberland, consisting of the corps of Howard, Palmer, and Hooker, in all 60,000 strong, constituted the centre, and made the opening demonstration on Buzzard's Roost and Rocky-Face Ridge. On May 15 Thomas drove the enemy from the hills in his front at Resaca. Thereafter he assaulted the fortifications at New Hope Church; took part in severe conflicts near Dallas; on June 22 repulsed the sudden onset of Hood's corps; and on the 27th led his columns in their disastrous attack on the enemy's strong position on Kennesaw Mountain. It was his command that, on July 20, met and repelled Hood's furious onslaught with severe loss, and Palmer's corps supported the Fifteenth in beating back the magnificent Confederate charge on the 28th. On Sept. 1, at Jonesboro', his Fourteenth corps carried the enemy's intrenchments, making prisoners of nearly an entire brigade, while Slocum, with his Twentieth corps, entered Atlanta, and completed the great task. There were, indeed, few great battles on this wonderful march, but in nearly every encounter Thomas took a part. To Sherman is due the merit for the grand scheme of the campaign, but his plans would never have borne their full fruit but for the hearty and intelligent co-operation of his subordinates, among whom Thomas held the first place.

Now came a total change in the Confederate plans. Hood had superseded Johnston, and, instead of

attempting directly to impede Sherman's advance, thought to draw him back from the South by himself making a demonstration against the North. Moving, therefore, from before Sheridan westward, he turned north, his objective point being the Ohio. As soon as he began his northward march Sherman despatched Thomas to Nashville to check Hood and protect his own rear, but still proceeded on his "march through Georgia, smashing things to the sea." Thomas had under him on reaching Nashville only 22,000 infantry and 7700 cavalry, with sundry small garrisons and detachments guarding railroads. At this city, while waiting the arrival of Gen. A. J. Smith, he occupied himself in strengthening his army, having given Gen. Schofield instructions to impede Hood's advance, and, when seriously threatened, to fall back on Franklin. This movement Schofield successfully effected. When Hood assailed his lines there on Nov. 30 he drove him back with a loss of 6000 men. (See FRANKLIN.) During the night Schofield fell back on Nashville, and on the same day Gen. Smith's command arrived. Hood followed Schofield to Nashville, and now professed to besiege it. A terrible awakening awaited him. On Dec. 15 Thomas, sallying forth, made his grand attack, and rolling up Hood's lines from left to right, drove him for eight miles to a position he had previously selected. In front of this position the Union troops bivouacked, and, on the 16th, renewed the assault, carrying the enemy's works and driving it in rout before them till darkness put an end to the pursuit. "Our line," says Hood, "was broken at all points, and, for the first and only time, I beheld a Confederate army abandon the field in confusion." Next day the chase was resumed, and continued unremittingly till the 29th, when Thomas learned that Hood had crossed the Tennessee at the head of "a disheartened and disorganized rabble of half-armed, barefooted men." For this decisive success Thomas was created major-general in the regular army, and received a vote of thanks from Congress. On the first anniversary of the battle he was presented with a gold medal by the State of Tennessee.

The battle of Nashville closed the last campaign in the West. During the final battles before Richmond Thomas remained in command of his department. He was not idle, however, but contributed to crushing out secession by organizing raiding bands, that resulted in the capture of Jefferson Davis. On June 30, 1865, under the act of Congress dividing the country into districts, Thomas assumed the command of the Military District (afterwards the Department) of Tennessee. This he held till March, 1867, when he was assigned to the Third Military District, comprising Georgia, Florida, and Alabama. While here he declined, in 1868, the rank of lieutenant-general, on the ground that it came too late, if intended as an acknowledgment of his service during the war, and that since the war he had done nothing deserving it. From May, 1869, he commanded the Military District of the Pacific, with head-quarters at San Francisco, where his death occurred March 26, 1876.

Gen. Thomas was a true man; spotless in character, a hater of ostentation, reserved even to reticence, self-poised, steadfast. In his manner and habits of thought he was deliberate, some thought to excess; his plans were slowly evolved and carefully matured; he never moved till he had perfected every detail, so that, when he did move, it was to assured success. No contingencies arose to perplex him, for he had prepared for all emergencies. His imperturbability in battle was amazing, and has already been referred to as eliciting the admiration of Garfield. He was, above all others, a man of system. At Chickamauga, when the enemy had routed the corps supporting him and had opened fire on his flanks and front, he replied to Steadman, who had reported to him, and who asked how the fight was going: "The scoundrels have no system." As might be inferred, the confidence of his

troops in him was complete; and this is evidenced by one of the names they gave him—"Old Reliable"—and their appreciation of his care for their welfare is yet more eloquently expressed by the other title they conferred on him—"Pap Thomas." Gen. Thomas has the glory, all but unique, of never having lost a battle when in independent command. When he served as a subordinate among other corps commanders he was ever the central figure. Though modest, above most men, he had yet a just appreciation of the value of his services, and when friends referred in his presence to the insufficient recognition these received he was wont simply to answer: "History will do me justice." Standing high among the noblest sons of the noble State of Virginia, his patriotism was not limited to the boundaries of State or section. His services to the cause of the Union were rendered chiefly elsewhere, and his fame is the inheritance of the undivided country which he helped to save.

(J. H.)

THOMPSON, JOSEPH PARRISH (1819-1879), preacher and author, was born at Philadelphia, Aug. 7, 1819. He graduated at Yale College in 1838, and was ordained pastor of a Congregational church at New Haven in 1840. His literary activity led him to join in founding the *New Englander*, a monthly magazine, in 1843, and afterwards the *Independent*, in 1848, at New York. He had been called to this city in 1845, and in the Broadway Tabernacle he gathered a large and influential congregation. With tongue and pen he was diligent in promoting religious and benevolent enterprises. On a visit to Egypt in 1853 he became interested in the study of its monuments, and when in 1871, worn out with the incessant demands on his time and strength, he was compelled by ill health to resign his charge, he removed to Berlin to pursue his archaeological investigations. But some of his most important public work was done in this new field of activity, where he obtained great favor with sovereigns and statesmen. His *Church and State in the United States* (1873) diffused effectively in Europe the American idea of religious liberty. In 1878 the Berlin Congress, through his influence, inserted a clause in its treaty favoring this idea. The Evangelical Alliance found in him one of its strongest supporters. In various parts of Europe he delivered lectures which developed and explained American ideas. Exhausted with his multifarious labors, he died at Berlin, Sept. 29, 1879. His books and other publications but partly reveal his ability and range. Besides some biographies he had published *Views of Egypt* (1854); *Love and Penalty* (1860); *Christianity and Emancipation* (1863); *Holy Comforter* (1866); *Theology of Christ* (1870); *Life of Christ* (1875).

THOMPSON, ROBERT ELLIS, economist and prominent defender of the protective tariff system, was born near Lurgan, Ireland, in April, 1844. His family emigrated to America in 1857, settling in Philadelphia. He graduated at the University of Pennsylvania in 1865, and, having studied theology, was ordained in the Reformed Presbyterian Church (N. S.) in 1873, but entered the Presbyterian Church in 1879. He had been assistant editor of the *American Presbyterian* from 1866 to 1870. He had returned to the University of Pennsylvania in 1868 as instructor in mathematics and Latin, and has since remained in connection with it, being made assistant professor of mathematics in 1870, professor of social science in 1874, and John Welsh Centennial professor of history in 1881. From the University he received in 1886 the degree of D. D. Prof. Thompson was editor of the *Fenn Monthly* from 1868 till 1879, and since that time chief editorial writer for the *American*, a political and literary weekly. He has also contributed largely to other periodicals on religious, political, educational, historical, and economical topics. He has delivered courses of lectures in elucidation and defence of the American protective system in Harvard, Yale, Williams, Amherst, and

other colleges. He has published *Social Science and National Economy* (1875), the third edition of which was revised under the title *Political Economy* (1883). His lectures before Harvard University were published under the title *Protection to Home Industry* (1886). He was the original editor-in-chief of this *Supplement*, but after two volumes had been prepared the work passed into other hands.

THOMSON, CHARLES (1729-1824), secretary of the Continental Congress, was born at Maghera, near Londonderry, Ireland, Nov. 29, 1729. With his family he sailed for America in 1741, but his father died on the voyage. He was taught by Rev. Francis Alison, at Thunder Hill, Md., and became a teacher first at Newcastle, afterward at Philadelphia. Through the friendship of Franklin and other influential men he was employed in negotiating treaties with the Indians, and the tribe of the Delawares adopted him as the "Truth-teller." He was engaged in mercantile business for some years, and was secretary of many literary and patriotic societies. Hence when the first Continental Congress met in Carpenters' Hall, Philadelphia, Sept. 5, 1774, they readily chose him as secretary, and he retained this position in each successive Congress until the adoption of the Federal Constitution in 1789. Then he was commissioned to notify Gen. Washington of his election to the Presidency, but declined any further public service. He spent many years in translating the Bible into English, using the Septuagint for the Old Testament. After his version was published in 1808 (4 vols.), he prepared from it a *Synopsis of the Four Evangelists* (1813). He died at Lower Merion, Pa., Aug. 16, 1824.

THOMSON, WILLIAM, Archbishop of York, England, was born at Whitelaven, Cumberland, Feb. 11, 1819. He passed from Shrewsbury School to Queen's College, Oxford, where he was in succession scholar, fellow, dean, bursar, tutor, and provost. Graduating in 1840, he was ordained deacon 1842, and priest 1843. After four years' parish work at Guildford and Cuddeston, he returned to his college as tutor, was appointed select preacher at Oxford 1848 and 1856, and provost 1855. In the same year he accepted the crown living of All Souls, Marylebone, and contributed to the *Oxford Essays*. In 1858 he became preacher at Lincoln's Inn, and in 1859 one of her Majesty's chaplains. Lord Palmerston procured his appointment to the see of Gloucester and Bristol in December, 1861, whence he was translated to York a year later, and enthroned Feb. 24, 1863, succeeding Dr. Longley. He has been active in educational and ecclesiastical reforms, had charge of the Public Worship Regulation Act in the House of Lords, and procured the appointment of a royal commission on church patronage. He is president of the Palestine Exploration Fund, a member of the Royal and Geographical Societies, a lord of the privy council, governor of the Charter-house and of King's College, London. He has been examiner in divinity at Oxford and in logic and mental science to the Society of Arts. Eminent as a scholar and metaphysician, he has published *An Outline of the Necessary Laws of Thought* (1842), largely used in England and America as a text-book on logic; *The Atoning Work of Christ Viewed in Relation to Some Current Theories* (The Bampton Lectures), 1853; *Sermons Preached in Lincoln's Inn Chapel* (1861); and *The Limits of Philosophical Enquiry* (1869), besides many charges, discourses, and contributions to Smith's *Dictionary of the Bible* and other works. He edited *Aids to Faith* (1861), a reply to *Essays and Reviews*, and projected *The Speaker's Commentary*. As archbishop of York he has an income of £10,000 and the patronage of 96 livings.

THOMSON, SIR WILLIAM, British mathematician and physicist, was born at Belfast in June, 1824. His father, James Thomson, LL. D., was then lecturer on mathematics in the Royal Academical Institute in Belfast, but afterwards removed to Glasgow, having been

appointed professor in the University of that city. The son was educated in that institution and at Peterhouse, Cambridge, where he graduated in 1845 and became a fellow. In 1846 he was made professor of natural philosophy at Glasgow, and has since retained that post. He was the editor of the *Cambridge and Dublin Mathematical Journal* from 1846 to 1853, and to it contributed valuable papers. He gave especial attention to electrical science, and invented several beautiful and delicate machines for investigating atmospheric electricity. Among his other inventions are the mirror galvanometer and the siphon-recorder, which proved of great service in submarine telegraphy. On the successful completion of the Atlantic cable in 1866, to which he had greatly contributed, he received the honor of knighthood. He also received the degree of LL. D. from the Universities of Dublin, Cambridge, and Edinburgh, and that of D. C. L. from Oxford. In 1871 he was chosen to preside at the meeting of the British Association in Edinburgh, and in 1881 was president of the section of mathematics at the meeting of the association in York. He has also received many marks of honor from foreign societies and academies. His *Mathematical and Physical Papers* were collected in a volume published at Cambridge in 1882.

THOMSON, WILLIAM McCLEURE, missionary, was born at Springfield, near Cincinnati, Dec. 31, 1806. He graduated at Miami University in 1826, studied theology at Princeton, and was ordained as an evangelist in 1831. He was sent as missionary to Syria in 1833, and labored there until 1876 with two intervals of rest, in which he returned to the United States. He is best known as the author of *The Land and the Book* (2 vols., 1859), in which in a conversational method vivid illustrations of the Bible are drawn from the scenes, manners, and customs of Palestine. The work has been thoroughly revised and enlarged in three volumes, *Southern Palestine and Jerusalem* (1880), *Central Palestine and Phœnicia* (1882), *Lebanon, Damascus and Beyond Jordan* (1886). Dr. Thomson now resides in New York city.

THORNTON, MATTHEW (1714-1803), a signer of the Declaration of Independence, was born in Ireland in 1714. His father soon removed to Wiscasset, Maine, and thence to Worcester, Mass. The son became a physician and accompanied Sir William Pepperell's expedition to Louisburg. He was also active in militia affairs, and in 1775 was president of the New Hampshire Convention. This body was divided into two houses in 1776, and Thornton became speaker of the assembly. He was not elected to the Continental Congress until September, yet on his appearance in it in November he was allowed the honor of signing the engrossed copy of the Declaration. He continued to attend Congress until the end of 1777, and then returned to New Hampshire, where he was Judge of the Superior Court until 1782, and held other offices. He died June 24, 1803, while visiting his married daughter at Newburyport, Mass.

THORNWELL, JAMES HENLEY (1812-1862), Presbyterian theologian, was born in Marlborough district, S. C., Dec. 9, 1812. Most of his life was spent at Columbia, S. C., either at the South Carolina College, or in the Presbyterian Theological Seminary. In the former he graduated in 1831, and after a brief experience in teaching and as pastor of a church at Lancaster, S. C. (1835-8), he returned to be professor of logic and belles lettres. His service was interrupted by a pastorate of a year in Columbia (1840-1), and six months in Charleston (1851). After the former his position was changed to that of chaplain and professor of Christian evidences, and after the latter he was called to the presidency. In 1855 the Presbyterian synod appointed him professor of didactic and polemic theology in their seminary, and this position he held till his death at Charlotte, N. C., Aug. 1, 1862. He had twice visited Europe for the sake of his health. He was well versed in ancient

and modern literatures, eminently successful as an instructor, and the most prominent leader of the Southern Presbyterian Church. His views were set forth in the *Southern Quarterly Review*, which he founded and edited from 1855 to 1857. In politics he strictly followed John C. Calhoun, and in theology John Calvin. Rev. J. B. Adger edited his *Collected Writings* (2 vols., 1874) and Rev. B. M. Palmer, D. D., his *Life and Letters* (1875).

THURMAN, ALLEN GRANBERRY, statesman, was born Nov. 13, 1813, at Lynchburg, Va. His father, a minister of the Methodist Episcopal Church, removed to Chillicothe, Ohio, in 1819, and here Allen received an academical education. After some experience as a surveyor he studied law with his uncle, William Allen, afterwards governor of Ohio, and with Judge N. H. Swayne, afterwards a justice of the U. S. Supreme Court. He was admitted to the bar in 1835 and soon was active in both law and politics. In 1845 he was elected to Congress, and in 1851 to the Supreme Court of Ohio, of which he became chief-justice in 1854. His term expired in 1856 and he returned to practice at the bar. In 1867 he was Democratic candidate for governor but was defeated by Rutherford B. Hayes, although Thurman had exhibited remarkable power as a campaign-speaker. The Legislature, however, was largely Democratic and elected him to the U. S. Senate, which had then only eleven others of his party. James G. Blaine in his *Twenty Years of Congress* pronounces Thurman then "the foremost man of his party in the nation." As such he vigorously supported the restoration of the government of the Southern States to the native whites. He stood firmly for the maintenance of gold and silver as the currency of the country, and resisted the Greenback movement. He opposed Chinese immigration and sought to maintain the control of the general government over the Pacific railroads. In 1881 his term as Senator expired, but Garfield, who had been chosen by the Legislature to succeed him, having been subsequently elected President, showed his friendly regard for Thurman by appointing him a delegate to the international monetary conference at Paris. Thirteen nations were represented, and the conference recommended the remonetizing of silver, but the disinclination of the English government prevented definite action on the part of any. After a tour through Europe Thurman returned to the United States and was soon active in his profession. In 1885 he was retained to assist government counsel in the suit against the Bell Telephone Co., but the cases were decided against the government. In some Democratic national conventions Thurman had been suggested as Presidential nominee and in 1876 he was a prominent candidate. In the convention of 1884 he received 88 votes on the first ballot. In 1888 a movement was started a few days before the meeting of the convention at St. Louis to name him for second place on the ticket, the first being accorded to Pres. Cleveland. When the convention met the proposal received general approval and he was nominated on the first ballot. Mr. Thurman, in spite of his age, exerted himself gallantly in the canvass, but his ticket was defeated by a decisive vote.

THURSTON, ROBERT HENRY, engineer, was born at Providence, R. I., Oct. 25, 1839. His father, Robert L. Thurston (1800-1873), was a successful builder of steam-engines. The son graduated at Brown University in 1859 and was engaged in his father's business until 1861, when he entered the navy as officer of engineers. He served in the North and South Atlantic squadrons throughout the war. He was then made assistant professor of physics in the U. S. Naval Academy. In 1870 he went to Europe to study iron-manufacture and on his return was appointed professor of mechanical engineering in the Stevens Institute, Hoboken, N. J. In 1873 he was a member of the U. S. scientific commission to the Vienna Exhibition, and edited the *Report of the commissioners*,

besides publishing his own *Report on Machinery and Manufactures* (5 vols., 1875-6). He was a member of the U. S. commission on steam-boiler explosions. In 1885 he was made director of Sibley College, or school of mechanical engineering and the mechanic arts, in connection with Cornell University, Ithaca, N. Y. Prof. Thurston has invented numerous improvements in mechanical devices. His many papers on scientific and technical topics have been published in both European and American journals. His *History of the Steam-Engine* is the standard work on the subject.

TIFFIN, a city of Ohio, county-seat of Seneca co., is on the Sandusky River, 34 miles S. W. of Sandusky, on the Cincinnati, Sandusky, and Cleveland Railroad and two other railroads. It has a court-house, 2 national banks, a savings bank, 16 churches, a convent, a high-school and other schools, and is the seat of Heidelberg College, which was founded in 1850 by the Reformed Church. Tiffin has 2 daily and 4 weekly newspapers. Its manufactures include agricultural implements, carriages, stoves, furniture, woollen goods, tiles, etc. Its population in 1880 was 7879.

TILLANDSIA, the generic name of a plant known by the various names of long moss, old man's beard, etc., belonging to the *Bromeliaceae*, or pine-apple family, most of the members of which are epiphytes, or air-plants. *T. usneoides*, the common long moss, occurs abundantly in the Southern States, hanging in masses of long, dark, swaying fibres from the branches of the live-oak and other trees, and constituting a peculiar feature of Southern woodland scenery. There are in all eight species of *Tillandsia* in the United States, but the above named is the best known. Its stems are thread-like and pendulous, its leaves awl-shaped, its flowers sessile and small, the petals imbricated and tube-like below, spreading above, the seeds erect on long stalks. This plant is found in humid districts, from the Dismal Swamp southward, becoming very abundant in the Gulf States, and has considerable economic importance; its fibrous masses being extensively used for stuffing mattresses, cushions, bird-skins, etc. For these purposes it is one of the best of materials. The plant is also an ingredient in an ointment which is said to be useful for hæmorrhoids. In winter it is eaten by cattle. (C. M.)

TIME, STANDARD. The introduction of railroads and the invention of the telegraph, and the constant use of these modern facilities of intercourse, have forced upon the popular mind in America more than elsewhere attention to the fact of differences of local time, and given that fact a commercial bearing. Places on the same meridian have the same solar time, but places on different meridians, whether on the same parallel or not, differ in time according to their longitude. The proper management of railroads was early found to require the fixing of a standard of time, and each road undertook to establish a standard suited to its locality. But the great through lines of the United States, running chiefly east and west, found it difficult to secure such harmony among their different sections and connections as was absolutely necessary for safe and satisfactory working. In 1880 there were over fifty railroad standards of time used in the United States, and at the intersection of various roads these standards varied and conflicted in most perplexing ways. Nearly every railroad centre had two or three standards. Three were used in Chicago, five in Kansas City, six in St. Louis. The smaller cities readily adopted the time of the railroads which passed through them, though some took pride in having accurate solar time for the town-clock.

The establishment of the U. S. Signal Service, with its constant use of the telegraph at fixed times, brought before eminent scientists the practical consideration of the problem which was already annoying the railroad managers. Prof. Cleveland Abbé suggested the simple and ingenious plan which eventually,

with some modifications, was adopted by the railroad lines of the United States, and put in operation on Nov. 18, 1883. According to this system, this country, extending from 65° to 125° W. long., was divided into four time-sections, each of 15° of longitude, exactly equivalent to one hour. The objects aimed at by the railroad managers were to have as few standards as possible, yet so arrange them that the variation from mean solar time at any point within the section regulated by the standard should not exceed 30 minutes, and that the changes in the standard should take place at well-known points of departure, chiefly at the termini of the roads. The system adopted meets all of these requirements.

The 75th meridian west of Greenwich, which passes between New York and Philadelphia, gave an excellent starting place. Its time was adopted for the District of Columbia by act of Congress approved March 13, 1884. According to the division of the country suggested by Prof. Abbe and adopted by the railroad companies, the first section, which is governed by the time of that meridian, includes all the territory between the Atlantic coast and Detroit, Pittsburg, Wheeling, Parkersburg, W. Va., Huntington, Bristol, Tenn., Augusta, Ga., and Charleston (the last being its most Southern point). The time of this section is called Eastern time, and it is marked by the dropping of time balls at noon by the aid of the telegraph from the U. S. Naval Observatory and other observatories. The second section includes all the territory from Detroit and the other western limits of the first section to Bismarck, Dakota, North Platte, Dodge City, etc. It includes nearly all the Mississippi Valley, the Gulf States, and the greater part of Georgia. Its time is governed by that of the 90th meridian, and is called Central time. It is one hour slower than Eastern time. The third section extends from the western limit of the Central section to Helena, Montana, Ogden, Utah, and the western boundary of Arizona. Its time is that of the 105th meridian, and is called Mountain time. The fourth section covers the rest of the country to the Pacific Ocean. The time is that of the 120th meridian, and is called Pacific time, being one hour slower than Mountain time.

One great advantage of this system is that the difference in time between prominent places is always an exact number of hours. At 12 noon in New York city the time at Chicago is 11 A. M.; at Denver 10 A. M.; at Portland, Oregon, 9 A. M.

It is probable that the system of standard time, successfully inaugurated in this country, will eventually be adopted throughout the world. An international congress of scientists was held in Washington in October, 1884, at which the meridian of Greenwich was recommended as a common prime meridian to be used in reckoning longitude throughout the world. When this has been adopted by the great commercial nations, it will be an easy step to have time reckoned from meridians exactly a certain number of hours west of that prime meridian, as is now done across the North American continent. (J. P. L.)

TIMOTHY. See PASTORAL EPISTLES.

TIMROD, HENRY (1829-1867), a Southern poet, was born at Charleston, S. C., Dec. 8, 1829, his father being a well-to-do bookbinder with poetic tastes, who died while Henry was in childhood. After some preliminary training in his native city, young Timrod entered the University of Georgia, but ill health compelled him to leave before finishing his course. The study of law proved uncongenial to his poetic nature and he became a teacher. His earlier poetical pieces, which appeared, from about 1849 to 1853, in the *Southern Literary Magazine* and the short-lived *Russell's Magazine* (both of Charleston), attracted local notice. In 1850 he brought out a small volume of his poems through Ticknor & Fields of Boston. His feelings at this eventful period were intensely Southern, and on the outbreak of the civil strife he

became the Tyrtæus of the South. His lyrics, "A Cry to Arms" and "Carolina," as well as his addresses "To the Unknown Dead" and "To Spring," and his "Carmen Triumphale," breathe a spirit of almost feminine tenderness mingled with the fire of martial ardor. For some time Timrod was war-correspondent for the *Charleston Mercury*; in 1853 he removed to Columbia, S. C., where he became editor and part proprietor of *The South Carolinian*. This position promised a moderate competence, and in 1864 he married Miss Kate Goodwin. On the entrance of Sherman's army into Columbia, his office, printing-press, etc., were demolished and himself ruined. "My story for the last year" he wrote his friend Col. P. H. Hayne in March, 1866, "is beggary, starvation, death [he had lost a child], bitter grief, utter want." For a time he wrote editorials for *The Carolinian* of Charleston, and later was glad to act as temporary clerk to Gov. Orr. In 1867, owing to failing health, he on two occasions accepted the invitation of Col. Hayne to share his quaint home in the pine-woods of Georgia. Alarming hemorrhages drove him back to his home in Columbia, and he died there, Oct. 7, 1867. An enlarged edition of his poems and a sketch of his life by Paul H. Hayne appeared in 1873.

TIN. See METALS.

TITHES. See TABERNACLE.

TITUS. See PASTORAL EPISTLES.

TITUSVILLE, a city of Pennsylvania, in Crawford co., is on Oil Creek, 18 miles N. of Oil City, and on three railroads. It has a national bank and other banks, an opera-house, 10 churches, a high-school and other schools, 1 daily and 3 weekly newspapers. Its business prosperity has fluctuated with that of the oil region in which it is situated. While still principally engaged in this business it has also iron-works and barrel- and wagon-factories. It has a good system of water-works. In 1880 its population was 9046.

TOAD, the common name of the batrachian family *Bufo*, sub-order *Anura*, or tailless See Vol. XXIII. Amphibians. The toads differ from p. 422 (p. 450 the frogs, the other family of the Am. Rep.). *Anura*, in having the shoulder girdles in an embryonic state, and in being destitute of teeth, also in being more terrestrial in their habits. They have a thick and heavy body, covered with wart-like glands which secrete an acrid fluid, the fore and hind legs are nearly equal in length, the tongue is well developed and can be protruded with great rapidity in the capture of insects. They absorb moisture by the skin, which is cast off at intervals and swallowed. Their life in water is confined to the breeding season, ordinarily March and April, the remainder of their life being passed on land. They spend the winter in holes and crevices in a torpid state. The toad has been long regarded as venomous, though without warrant. Its glandular secretion may cause painful irritation of a tender or abraded skin, but can do no further harm, and the animal is entirely inoffensive and of great usefulness to man, as it destroys great numbers of insects injurious to vegetation. Toads have been known to live 35 or 40 years, and can survive for a long period without food and with little air, though the stories of their being able to live for years or centuries hermetically sealed in rocks and trees need confirmation. Experiments in this direction show that toads cannot long survive if deprived of air.

Toads are found all over the world, though most abundantly in the tropics. Ninety-two species are enumerated in the family, of which 77 belong to the typical genus *Bufo*. Of this genus the largest species is *B. macinus* of tropical America, of which individuals 8 inches long are often found. The United States has about 10 species of *Bufo*, of which the common eastern species is *B. lentiginosus*. This species occurs from Maine and Canada to the Mississippi Valley, and to the Gulf States, in which the typical form (with bony knobs or crests above the eyes) is found.

It is 2½ to 3 inches long, with a thick warty body, colored with spots of varying hue, size, and shape, the lower parts a dirty yellow. It is quicker in its movements than the common European toad. The variety found in the northerly region lacks the knobs over the eyes, and is classed as the sub-species *B. Americanus*. From Massachusetts to Canada still another variety is found, with an osseous ridge on the skull.

B. Americanus in the Middle States is a common inhabitant of gardens and other localities where insects abound. It is crepuscular in habit, its quiet but sudden movements being familiar to all. It is the earliest of the Batrachia to enliven spring with its note, as it rests on the water while depositing its spawn and continues to sing well into the summer. The eggs are deposited in a long, rope-like tube of transparent albumen, which gathers into a coil on the bottom of the water. When the young, after their transformation from the tadpole to the mature toad form, leave the water they make long journeys in the evening, hiding during the day. If rain falls they emerge from their hiding-places, thus giving rise to the supposition that they have been rained down to the earth.

A more localized and very small species, *B. quercinus*, ranges from North Carolina to Florida. The largest North American species is *B. boreas* of the Pacific region, which is sometimes nearly as large as *B. maximus*. In the upper Mississippi region is a small species, *B. dipertus*, which has two well-developed tarsal spurs for the purpose of excavating. This peculiarity, which is found in some other species of *Bufo*, is well developed in *Rhinophrynus dorsalis* of Mexico, whose remarkably strong shovel-like excavator enables it to rapidly make its way into the ground.

The members of the batrachian family, *Plebotidae*, are nearly all subterranean in their habits. The American species of this family are exceedingly noisy at the time of depositing their eggs. *Scaphiopus holbrookii*, the hermit spade-foot toad, is common in the Middle States. Other species are found in the South-west, some of them with remarkably loud cries. Of the family *Hylidae*, or tree-toads, there are about 175 species, principally found in tropical America. The typical genus *Hyla* has 95 species, of which the common tree-toad of the United States is *H. versicolor*. This lays its eggs in the water on some fixed body, as an aquatic plant. The species of this family are noted for their loud and varied cries, the first note of spring in the United States being the shrill piping of *H. Pickeringii*, a swamp-dwelling species. This creature continues to sing into the fall, but not with the loudness and liveliness of his springtime note. The *Hylidae* are often brilliantly colored, and some of them are remarkable for their great changes of hue to accord with the surface on which they rest. *H. versicolor* when resting on a tree-trunk may be of a dull brown or a pale gray, representing a lichen; but when among tree-leaves becomes of a bright green. Those species which live among flowers and varied foliage are often very brilliant in their hues.

Another family of toads, the *Pipidae*, are tongueless, and differ in other respects greatly from those described. One species, *P. Americana*, the Surinam toad, has a remarkable habit, without counterpart in the order. The eggs are not laid in the water, but are received by the male, who deposits them on the back of the female. The skin thickens between the eggs thus deposited, till each is invested in a sort of sac, which is covered with a thin, gelatinous operculum. The young go through their metamorphoses in these sacs, the tail and branchiæ being absorbed while they are still in the egg. They emerge perfect frogs. This species is common in the dark corners of houses in Guiana, and is said to be eaten by the natives, in spite of its repulsive aspect. (C. M.)

TODD, JOHN (1800–1873), Congregationalist preacher and author, was born at Rutland, Vt., Oct. 9, 1800. His early life was a struggle with poverty

but he gained an education at Yale College, graduating in 1822, and then studied theology at Andover. He was pastor of a church at Groton, 1827–31, the congregation comprising many Unitarians. Afterwards he had charges at Northampton (1833–36), at Philadelphia (1836–42), and then at Pittsfield (1842–72). He was not only a strenuous upholder of Calvinism, but was active in the promotion of education. His own experience was largely embodied in his *Student's Manual* (1835), which had an immense circulation. Other books of a similar kind, such as *The Daughter at School* (1854), were less sought after. Dr. Todd assisted in founding Mount Holyoke Female Seminary, and was president of the Young Ladies' Institute at Pittsfield. Among his later books were *Mountain Gems* (1864), *Sunset Land* (1869), giving his impressions of California, and *Old-Fashioned Lives* (1870). In *Woman's Rights* (1867) he took a conservative view of the subject which provoked a reply by "Gail Hamilton" under the title *Woman's Wrongs*. Dr. Todd died at Pittsfield, Aug. 24, 1873. See *John Todd; the Story of his Life*, edited by his son, Rev. J. E. Todd (1876).

TODD HUNTER, ISAAC, English mathematician, was born at Rye, in 1820. His father was of Scotch descent and minister of a Dissenting congregation. The son was educated first at University College, London, then taught school at Wimbledon, and entered St. John's College, Cambridge. He graduated as senior wrangler in 1848, and became fellow, assistant tutor, and mathematical lecturer of his college. His school and college text-books on the various branches of mathematics have had extensive circulation in Great Britain and America. Besides these he has published *History of the Progress of the Calculus of Variations during the Nineteenth Century* (1861), and *History of the Mathematical Theories of Attraction and the Figure of the Earth from Newton to Laplace* (2 vols., 1873).

TOLEDO, a city of Ohio, county-seat of Lucas co., is on the Maumee River, 8 miles from Lake Erie. It is 92 miles W. of Cleveland and is an important railroad town. It has a good harbor and a channel 17 ft. deep, has been dredged through the Maumee Bay to the lake. Large elevators, with storage for 5,000,000 bushels, and the immense union railroad depot afford facilities for the shipment of grain and flour. There is also a large trade in lumber, live-stock, hides, wool, iron, and tobacco. The manufactures include carriages, wagons, pumps, steam-engines, agricultural implements, furniture and cabinet-ware, etc. There are also boat-yards and bridge-works. Toledo has a courthouse, 7 national banks, 6 other banks, 60 churches, a good system of public schools, several private schools, a free public library, 3 hospitals, 3 orphan asylums, and other charitable institutions. Three daily and 11 weekly newspapers are published here. The city is governed by a mayor, a board of aldermen, and a common council. It has a good supply of water and a paid fire department. Toledo was formed in 1836 by the union of two villages, and in 1880 it had attained a population of 50,137.

TOLSTOI, COUNT LYEF NIKOLAIEVITCH, a Russian novelist and reformer, was born near Tula, Aug. 28, 1828. He is descended from Count Peter Tolstoi, a friend of Peter the Great. Among his contemporary relatives were Count Dimitri Tolstoi, minister of public instruction (1866–80), noted as an active agent of autocracy and enemy of liberty, and Count Alexis Tolstoi (1817–73), author of a trilogy of tragedies, *The Death of Ivan the Terrible*, *Czar Feodor*, and *Czar Boris*. Lyeff (or, as the name is commonly written in English, Lyof or Leo) was early orphaned, and was educated on his maternal estate of Jasnaja Polyana, except for two years, 1843–5, at the University of Kazan. In 1851 he went with a brother to the Caucasus and entered the army. There he wrote his first books, *The Cossacks* and *Childhood and Youth*.

An English version of the latter, by Malwida von Myenberg, was published at London, 1862, but attracted no especial attention; and though Tolstoi was an industrious writer from the start, his fame was for many years confined to his own country. At the beginning of the Crimean war, 1853, he was transferred to the Danube, and served on the staff of Prince Gortschakoff. In the defence of Sevastopol he commanded a battery: the painful experiences of that year are described with accurate detail in *Sevastopol in December, in May, and in August*. On the conclusion of peace he resigned his commission and made literature his chief employment, spending the summers on his estate and the winters in Moscow, where he married the daughter of a German physician. *War and Peace*, his longest book, appeared 1869. The next year he became a magistrate, and thenceforth lived chiefly in the country, striving for the instruction and improvement of his peasantry, teaching in the schools, and writing educational books. His most widely read novel, *Anna Karenina* (1876-77), bears witness to his varying interests, and indicates (perhaps unconsciously) his ripening disgust with society and the conventional modes of life. Soon after its appearance he wholly abandoned these and adopted the peasant's garb and humble labors, in pursuance of a scheme of socialistic philosophy, which he rather developed from within than learned from without. *My Religion* appeared in the *Nouvelle Revue*, and *Christ's Christianity* in an English translation in 1885. His peculiar views are set forth in these and others of his books, many of which, however, are not allowed to be printed in Russia, but circulate in MS. among his numerous admirers. His theology, at once highly mystical and profoundly rationalistic, has been explained by Miss Hapgood in the *Nation* for Sept. 27, 1888. It is understood to deny the divinity of Christ, the special inspiration of the Scriptures, the validity of prayer, and the immortality of the soul; yet he reveres Jesus as a supreme example of influence, and accepts literally the praise of poverty, the injunction of passive submission, and the enforcement of love to one's neighbor: these he obeys with unfashionable consistency and unflinching zeal. Ecclesiastical authority he rejects, and would substitute "member of the Orthodox Greek Church" for "Pharisee." Nor will he enter or approve a dissenting sect, for he despises all organizations, and holds the spirit to be above them and independent of them. In an evil world absolute non-resistance, he holds, is alike the only policy for those who have or seek the light, and the only true obedience to gospel precepts. Circumstances prevent his carrying out his views fully, yet he has arranged his life in a manner which in any civilized land must provoke amazement, and cause his sanity to be questioned. He professes to regard his past life with bathing, as regulated by the false opinions and customs of society. Having tasted wealth, rank, warfare, pleasure, fame, he has found them vanity and vexation and been driven to seek eagerly for the peace of faith. To Mr. Kennan, the Siberian traveller, "he spoke slightly, almost contemptuously, of his works of fiction, and seemed to regard them as monuments of misdirected energy." (See *A Visit to Count Tolstoi*, in the *Century Magazine*, June, 1887.) He works at the shoemaker's bench and in the fields, and lives on terms of absolute democratic equality with peasants. Yet he writes as vigorously as ever tracts and stories, which are sermons, for the common people and their children; over them his influence is said to be powerful and widespread. A sort of Russian Buddha, the object nearest his heart is their improvement and the coming of that millennium in which men, relieved from the incubi of organized religion and government, shall dwell together in equality, peace, and mutual brotherly helpfulness. To contribute to this end is his one desire; and the government, which is swift to suppress an argument or a treatise, often allows the same revolutionary ideas

to appear in the guise of tales. A collection of Tolstoi's works in ten volumes appeared in 1880, but he has written much since then, and his bibliography is for the future historian.

Tolstoi's vogue in America has arisen since 1885. A writer in the *Nineteenth Century* said in 1879 that neither of his two greatest books seems likely to be translated into English. A version of *The Cossacks*, by Eugene Schuyler, when brought out in New York, attracted so little notice that the publishers determined to venture on no more of his. Since then, however, everything bearing his name has been welcomed, and a single house has issued some fifteen volumes of his writings, several of which are on the market in more than one version. The translators are Nathan Haskell Dole, Isabel F. Hapgood, Mrs. Aline Delano, and Huntington Smith; some are rendered from the original, others through the French. *War and Peace* and *Anna Karenina* are novels of great length; other volumes, as *A Russian Proprietor* and *The Long Exile*, are named from one of sundry short stories. The list includes *The Cossacks*; *Sevastopol*; *Katia*; *Ivan Ilyitch*; *The Invaders*; *In Pursuit of Happiness*; *What People Live by*; *Family Happiness*; *Childhood, Boyhood, and Youth*; *My Confession*; *My Religion*; *The Physiology of War*; *Napoleon and the Russian Campaign*; and *What to do: Thoughts Evoked by the Census of Moscow*.

Except perhaps Turgeneff, Tolstoi ranks as the first of Russian authors. He has his votaries and his opponents: Mr. W. D. Howells is unstinting in his praise, while Maurice Thompson decries him as an injurious writer and a "socialistic crank." His earlier and secular books illustrate with unsurpassed power the virtues and vices of the realistic school; those produced since he awoke to his mission, though often couched in the plainest language and dealing with the daily life of peasants, are loftily idealistic in spirit and conception. His genius is now generally conceded, and few would deny the purity of his motives and the nobleness of his aims; but as to the enjoyableness of his books, no less than the beneficial tendency of the larger and more ambitious ones, opinions differ widely. The photographic minuteness of *Anna Karenina*, the relentless hounding of human weakness into crime and misery, are dreary and depressing to some, while *War and Peace* has been described as a huge and confusedly overcrowded canvas. The reader may with justice complain that these romances are no more edifying, no more agreeable, than real life. With more open and compressed cynicism, *Ivan Ilyitch* sets forth the worthlessness of common purposes and cares. As to his later and shorter tales, most would admit that they often, in spite of their elaborately plebeian dress, have force, point, and beauty, with an elevated and poetic moral. Tolstoi himself would indignantly repudiate the dictum of an American critic, "The domain of his genius is fiction and not the bewildering muddlements of pseudo-philosophy." The best essays on Tolstoi are in French, by M. de Vogüé and E. Dupuy. (F. M. B.)

TOMATO, the *Lycopersicum esculentum*, a plant belonging to the *Solanaceæ*, or night-shade family. There are numerous species of the genus, all of South American origin, though the esculent tomato is now grown widely throughout the world. It is cultivated for its fruit, which is a very important article of diet, though until recent years supposed to be uneatable. The tomato was introduced into England in 1596, but for many years was grown only as an ornamental plant or for medicinal purposes. It was known as love-apple, which name is still given it in France and Italy. It was first used as a vegetable in Italy, and soon afterwards in France and England, though it has been in general use for this purpose less than fifty years. It needs warm suns, and does not ripen to perfection in England, though it is grown there for market under glass. As at present used it is one of

the most important of our garden products. It is easily managed, even by inexperienced hands, and hundreds of acres are now planted with it in the vicinity of all our large cities.

The tomato plant has a weak stem of about 4 ft. in length, which is apt to trail or become prostrate. The leaves are irregular primate with large leaflets, the stem and leaves being clothed with soft viscid hairs of a strong, unpleasant odor and a somewhat resinous substance which leaves a stain. It bears racemose clusters of yellow flowers, its fruit being a 2- or 3-celled berry, though there are numerous cells in the cultivated varieties. Under cultivation the fruit varies greatly in color and size, the plant being highly plastic, though it is possible that the cultivated forms may represent several species. Half a century ago this plant was raised only as a curiosity, or as an ornament from its red fruit, but it is now one of the most popular and useful of vegetables. It ripens after plucking, and hence can be picked green and transported long distances, our northern cities being supplied from Florida and the Bermudas and gradually up the coast before the fruit ripens in their own vicinity. It is used in numerous ways, eaten raw as a salad, stewed, baked, broiled and in soups, stews, and sauces. Tomato catsup is a favorite relish, and vast quantities of tomatoes are put up for winter use by canning and preserving.

To produce early crops the seed is sown in hot-beds or forcing-pits some ten weeks before planting in the open air. In the Middle States this is done about the first week in March, transplanting being done in middle May. The plants are placed in light sandy soil, in hills 3 ft. apart, and well manured. The yield under careful cultivation is about 400 bushels to the acre, the average market price being about 75 cents per bushel. This seems profitable; yet there is much expense and labor needed in the forcing processes necessary for an early crop. In the South, where convenient to shipping, the raising of tomatoes for the Northern market is a very remunerative industry. In some localities thousands of acres of tomatoes are raised by farmers under contract for canning purposes. These often sell as low as 30 cents per bushel, but this will pay on suitable land better than most farm crops, there being no need to plant early for this purpose.

Of the many varieties of tomatoes now in the market, among the leading ones in the vicinity of New York are the Mikado, Aeme, Paragon, Perfection, Trophy, Red and Yellow Plum, General Grant, Hathaway's Excelsior, and Canada Victor. Elsewhere other varieties are more prominent. The Trophy has been in favor for many years, and is of unsurpassed size, flavor, and productiveness. Earlier and smoother varieties are now raised, though there has been no improvement in quality of varieties for twenty years past, and all further improvements seem likely to be in smoothness and solidity. The tomato is a plant which requires a high temperature to ripen its fruit, its time of ripening being May in Georgia, June in Virginia, July in Delaware, and August in New Jersey and New York. As a winter vegetable, in its canned state, it has hardly an equal among vegetable articles of diet, many millions of cans being annually used.

(C. M.)
TOMPKINS, DANIEL D. (1774-1825), vice-president of the United States, was born at Scarsdale, N. Y., June 21, 1774. He graduated at Columbia College in 1795, and was admitted to the bar in 1797. He was elected to the Legislature in 1801, and took part in the revision of the State constitution. Elected to Congress in 1804, he resigned to become an associate justice of the N. Y. supreme court. In 1806 he was chosen governor of the State, and during his tenure of this office he gave effective support to the war policy of the national administration in 1812. At a later period the incomplete and confused record of his financial transactions at this time were used to injure his reputation, and prove him a debtor to the State,

though the contrary was the fact. His opposition to banks was conspicuously shown by his proroguing the Legislature for ten months to prevent the Bank of America from being established in the city of New York. The bank, however, finally obtained its charter. In 1816 he was elected vice-president on the ticket with Monroe, and before leaving the governor's chair he recommended the passage of an act abolishing slavery in the State of New York. This was done, the act taking effect in July, 1827. Tompkins was re-elected with Monroe, and at the close of his term retired to Staten Island, where he died June 11, 1825.

TOOMBS, ROBERT (1810-1885), Southern statesman and orator, was born at Washington, Wilkes co., Ga., July 2, 1810. He was educated at the University of Georgia and at Union College, N. Y., and studied law in the University of Virginia. He began the practice of law in 1831, and was captain of a company of volunteers in the Creek war in 1836. He was then elected to the State Legislature, and in 1844 he was elected to Congress, where he became a prominent representative of the Whig party. After eight years' service in the lower house he entered the Senate, being now most aggressive in demands for national recognition and support of slavery. After the election of Pres. Lincoln he urged forward the movement for secession in Georgia, and even when the Union party, headed by A. H. Stephens, elected a majority of delegates to the State convention, Toombs succeeded in bringing about the passage of an ordinance of secession Jan. 17, 1861. Toombs then withdrew from the Senate with a threatening speech, which the Senate some weeks later answered by a resolution expelling him. Meantime he had been active in the Confederate Congress at Montgomery, Ala., and was a candidate for the presidency of the new Confederacy. Jefferson Davis, however, was chosen, and Toombs was made secretary of state. The position was not to his liking, and he obtained a commission as a brigadier-general. Though his unwillingness to obey orders rendered him troublesome, he stayed with the army in Virginia until the end of 1862, and then returned to Georgia, where he had command of State troops. At the close of the war he refused to acknowledge the sovereignty of the United States, and went to Europe by way of Cuba. He returned, however, in 1867, and resumed his law practice, but proudly declared himself an "unrepentant rebel." A man of massive frame, he claimed from all he met recognition of his physical and intellectual superiority. This granted, he showed himself patronizing and genial, but if denied, he was arrogant and blustering. He was a kind master to his slaves; he would permit no inn near his residence—"Liberty Hall"—but welcomed there any stranger who visited the neighborhood. Numerous anecdotes and sayings attest his domineering character in the Senate, but in the history of the Confederacy he left little impression. He died at Washington, Ga., Dec. 25, 1885.

TOPEKA, the capital of Kansas, and county-seat of Shawnee co., is on the Kansas River, N. lat. 39° 3', W. long. 95° 40', and 66 miles west of Kansas City. Four railroads, the Union Pacific, the Chicago, Kansas, and Nebraska, the Missouri Pacific, and the Atchison, Topeka, and Santa Fé, furnish abundant facilities for communication and trade with all parts of the Union. The city is also well supplied with street railways. It has a handsome capitol, 2 opera-houses, 4 hotels, 4 national banks, 3 other banks, 4 daily and over 25 weekly newspapers. There are 17 school-buildings, whose property is valued at \$300,000, 2 business colleges, a Catholic seminary, Washburn College (Congregational), Bethany College for young ladies (Episcopal). There are 45 churches, comprising nearly every religious denomination, and some possessing fine edifices. Two bishops—Episcopal and Methodist—have their residence here. The Prohibition law is enforced and generally approved. Near the city are the State Asylum for the Insane and the State Reform School. Besides the machine-shops

of the Santa Fé Railroad, the chief industrial works are 9 flouring-mills, whose yearly output is 400,000 barrels. There are also 3 iron-foundries, 2 packing-houses, and factories producing starch, vinegar, clothing, harness, cigars, tents, wheels, windmills, and agricultural implements. The city is well laid out with wide, shady, well-paved streets, and handsome residences. It has excellent sewerage, an electric-light and telephone system, gas- and water-works. Topeka was settled in 1854 and incorporated in 1858. Its early history is closely connected with the settlement of Kansas and its admission into the Union. Its population in 1880 was 15,452, but it is estimated in 1888 to be 40,000. Its assessed valuation in 1887 was \$7,270,017, the true value being thrice as much.

TORBERT, ALFRED T. A., general, was born in Delaware in July, 1833. He graduated at West Point in 1855, and was appointed brevet second-lieutenant of infantry. He served in Texas and Florida, and took part in the Utah expedition of 1857-58. When the civil war broke out he was employed in mustering New Jersey volunteers into service, and in September was made colonel of the First regiment N. J. volunteers. With his command he participated in McClellan's Peninsular campaign, and in August, 1862, he was assigned to the command of a brigade. He fought in the second battle of Bull Run, and was wounded at South Mountain. He was then made brigadier-general of volunteers, but was unable to serve until June, 1863, when he returned to his brigade in the Sixth corps in time to fight at Gettysburg. In 1864, while Gen. Sheridan conducted a raid on Richmond, Gen. Torbert commanded the cavalry which remained with Gen. Grant, and afterwards led the First division in several actions, including the battle of Cold Harbor. Gen. Torbert was now made chief of cavalry of the Middle military division, and was engaged in all the operations in the Shenandoah Valley. In April, 1865, he was made commander of the Army of the Shenandoah, and afterwards had charge of various districts, until he was mustered out of the volunteer service in January, 1866. In October of that year he resigned from the regular army, in which his actual rank was only captain, though he had brevet rank as major-general. He was sent as U. S. minister to Salvador in 1869, as consul-general to Havana in 1871, and to Paris in 1874.

TORNADO. There are two well-marked species of gyrotory storms—the cyclone, in which the wind moves mainly in a horizontal direction and covers an extensive area, and the tornado, in which the movement is principally vertical and the ground area of the storm very small. These two kinds of storm are connected by no intermediate gradations, and seem distinct in character and origin. The tornado, however, is connected with a series of less violent gyrations, ranging from the waterspout of the ocean and the sand-storm of the desert down to the little dust-whirl which is so ordinary a phenomenon in our streets. The violent form of whirl known as the tornado occurs more frequently and disastrously in the United States than in any other region of the earth, and is particularly prevalent in the valley of the Mississippi, where severe examples are of annual occurrence, and the loss of life and property often extensive.

The tornado, which apparently has its origin in the clouds at no great distance above the earth, presents the appearance of a vast cloud funnel, visibly descending from the layer of cloud in which it originates until it reaches the earth, where it draws up everything that lies in its path into its swift revolving vortex. Its cloud-like appearance is due to the condensation of moisture in the warm and compressed air of the wind-whirl, into which the adjoining air is drawn with great force and caused to revolve with extraordinary violence, the motion being an upward spiral, with a partial vacuum in its centre. The path of the tornado is always very narrow, averaging less than a quarter-mile in width, the greatest violence being in its

central region. In this region everything that is touched is destroyed; houses unroofed or torn to pieces, and their fragments thrown long distances; great trees twisted off like reeds; such weights as locomotives lifted and hurled aside, and a power displayed which it is difficult to appreciate. The whirling motion is indicated by the twisting of trees and the turning round of buildings which have been lifted from their foundations, while the mode in which the walls of houses occasionally seem to burst outward in all directions appears the work of a vacuum in the passing centre of the whirl.

The tornado cloud never seems to reach to a great height, but becomes lost in the broad layer of cloud from which it depends. It sways to and fro, like a dangling whip, as it moves rapidly along its path of destruction, the end occasionally rising from the ground to descend farther on. When thus raised it seems somewhat pointed at bottom, and though the surface wind is still severe, little harm is done. The path of greatest violence of the tornado is very narrow, while the time of passage of its centre over any spot is less than a minute, sometimes but a few seconds. It seems to strike everything within its reach a single blow, like that of a gigantic hammer which destroys whatever it touches. The wind pressure of the tornado has been estimated from its effects to vary from 18 to 112 pounds to the square foot, and the velocity of the wind to be sometimes as much as 2000 miles per hour.

Definite scientific observations of tornado phenomena have been confined to a few years past, this work having been taken up by Lieut. John P. Finley, of the Signal Service Bureau, who several years ago organized a system of regular observations which have added greatly to our knowledge of the subject. He has learned so much concerning the tornado conditions, in fact, as to be able to predict, with some degree of accuracy, the probable appearance of such storms within the settled regions of the country. In furtherance of this project he has sent blanks to competent persons throughout the tornado region, desiring them to describe the character and peculiarities of every tornado that came under their observation, and in this manner obtained a large sum of statistics. As a result of his studies on the subject it may be stated that of 38 predictions made by him in April and June, 1884, that tornadoes would occur, 18 were verified, and of 19 in June and July, 1885, 15 were verified. In all cases violent storms occurred, either tornadoes, fierce gales, or hail-storms.

His predictions are based on the following observed facts. Tornadoes are found to be always associated with cyclones, and always to make their appearance in the south-east quadrant of the cyclone, or south-east of a moving centre of low barometric pressure, while their tracks conform closely to the direction of the main storm. Their place of occurrence, however, is several hundred miles distant from the centre of the cyclone. The favorable climatic conditions are an elevation of temperature of from 15 to 50° above the normal, and an excessive humidity, with abnormal conditions of wind direction and cloud formation and movement. The average number of tornadoes which annually occur in the region east of the Rocky Mountains is over 100. In 1884 there were 172. Of 600 recorded occurrences from 1791 to 1881, 301 moved from south-west to north-east. As a general rule about 80 per cent. of them move in this direction, and about 10 per cent. from north-west to south-east. The average width of path is 1085 feet, and of velocity 30 miles an hour, though the velocity may vary from 1 to 150 miles per hour. The cloud is nearly always funnel-shaped, varying from the hour-glass to the conical and the inverted funnel forms. The direction of the whirl is almost invariably opposite to that of the movement of a clock-hand, in this respect agreeing with the gyration of the cyclone. Tornadoes move parallel to the pro-

gressive storm by whose side they are developed, keeping their average distance of several hundred miles from its centre. They occur most frequently in the months of May, April, June, and July, in the order given, and from 3.30 to 5 P. M., immediately after the warmest part of the day, and when warm ascending currents are most likely to meet cool descending currents.

In the United States 3000 persons have been killed and as many injured by these storms, while the loss of property reaches scores of millions of dollars. They occur most frequently in the States bordering the northern Mississippi and the lower Missouri. Here the warm and very moist winds from the Gulf meet with currents of cold air from the north, exceedingly unstable atmospheric conditions being produced. They seldom or never occur west of the 100th meridian, a region unvisited by severe cyclones. Of the various tornadoes on record the most remarkable series was that of Feb. 9, 1884. On that day, after 10 A. M., more than 60 tornadoes occurred in the States between Illinois and Virginia on the north, and Mississippi and Georgia on the south, at distances of from 500 to 2,000 miles from the cyclone centre. The damage was excessive; more than 10,000 buildings were destroyed, 800 persons killed, and 2500 wounded.

Thunder and hail-storms occur in the same advance quadrant of the cyclone with the tornado, and possibly all arise from the same general conditions. These storms are doubtless all due to the effort at equilibration in very unstable atmospheric conditions. The tornado is always preceded by warm and humid southerly winds, and followed by cold northerly ones. The preceding atmosphere is, in fact, saturated with vapor, its abnormally high temperature increasing its capacity in this respect. There is probably a very rapid diminution of temperature with altitude, and undoubtedly the large temperature gradients vertically, and the marked contrast of vapor conditions, have much to do with the development of the tornado, which is naturally propagated along the line and in the direction in which the unstable condition of equilibrium prevails. The gyration noticeably forms in the upper air, where the winds attain a much greater velocity than on the surface, and gradually descends. The warmth and high vapor conditions of the southern and eastern regions of the cyclone are doubtless the reason that tornadoes appear there and not in the northern and western regions, where the air is comparatively dry and cold, and the equilibrium of the atmosphere much less disturbed.

Several theories as to the immediate cause of tornadoes have been advanced. Guyot ascribed them to the meeting of opposite winds of different temperatures in the upper atmosphere. According to a more recent theory, the tornado is preceded by the formation of a surface layer of abnormally warm air, above which extends a layer of much cooler air. The former, in its effort to ascend, pierces the latter at some point, and rushes upward in a spiral whirl or eddy which quickly draws the surrounding warm air into its vortex. This theory is based on the analogy of the behavior of water under circumstances similar to those assumed, as, to adduce a familiar instance, when the stopper is pulled from the escape-pipe of a bath-tub. In this case the water rushes from all sides towards the vent, and eddies round in a descending spiral as it passes downward through the pipe, a water vacuum existing in the centre of the eddy. The analogy to the tornado seems very close, yet this theory, though supported by some eminent meteorologists, is hardly in accordance with the facts. Instead of the preceding calm conditions which it seems to require, the tornado is preceded by strong winds. Nor does it offer any explanation of the cold north winds which follow the tornado, nor of the rapid and somewhat regular progressive motion of the latter. It is in agreement with the water analogy, but hardly with the atmospheric conditions.

There are other water eddies, however, of more normal character, that of which we have spoken needing unusual conditions for its manifestation. The normal eddy requires moving water for its propagation, and never appears when this water moves steadily and regularly. But at the least disturbance of this regularity, eddies are generated, and increase in width and violence as the disturbance becomes greater. In short, the ordinary eddy is due to opposition to the movement of water currents, either from the meeting of two currents more or less opposed in direction, or from the impingement of a current on an unyielding obstacle and the hurling of the water back upon itself. The latter is the case in the tornado-like whirlpool at Niagara. In every case we have the meeting of two bodies of water which cannot pass each other, and whose progressive motion is converted into a whirl, while the accumulating waters can only escape downwards, so that the whirl is converted into a descending spiral.

This form of eddy appears to be the true analogue to the atmospheric eddy known by the various names of whirlwind, tornado, etc. In the latter case wind is always present, and apparently opposing winds. In the little dust-whirl of the streets this seems evident. It only appears during gusty winds, where the air currents frequently vary their direction, and it seems to indicate the meeting of two opposing puffs of wind, which break into an eddy as they meet, while the progressive motion of the whirl is due to the gradual meeting of the angularly opposed fronts of the currents. In this phenomena we probably have, on a small scale, what is repeated in the tornado on a large scale.

Before proceeding with the argument, however, a more particularized statement of tornado conditions is important. The disturbance, as already said, always begins in the upper air. Lieut. Maury, in 1882, attributed the tornado to an upper air current seen at times to move from the south-west at a speed of 100 miles per hour. Numerous descriptions show that the first tornado indication is a cloud to the northward, heavy, black, and comparatively slow in its southward movement. This is met by a light, rather smoky, and more rapid cloud from the south-west. These clouds, borne by their respective winds, rush together, violent conflicts of currents drive the clouds in every direction, up and down, round and round; clouds, like great sheets of white smoke, dash about in a frightful manner. Finally, a black, threatening mass descends slowly towards the earth, whirling violently, but still manifesting confusion in form. This soon gives place to the peculiar funnel-like shape, intensely black in appearance. As white clouds appear and are drawn into the vortex, the funnel trunk sways like an elastic column. Substances drawn up are seen flying in its centre, gradually rising, to be finally flung out near the top after the storm has progressed a mile or two. Dark masses of cloud shoot down the sides of the funnel, and are drawn into the vortex near the ground. At times the velocity appears to increase, and everything is torn to splinters. A peculiar hollow, rumbling, but very loud sound accompanies the storm.

This description of the genesis of a tornado, abbreviated from Prof. Eddy's paper in the *Popular Science Monthly*, is in accordance with the following description of the tornado of May 30, 1879, from the Signal Service Report:

"The cloud from which the funnel depended, seen at a distance of 8 miles, appeared to be in terrible commotion; in fact, while the hail was falling, a sort of tumbling in the clouds was noticed as they came up from the north-west and south-west, and about where they appeared to meet was the point from which the funnel was seen to descend. There was but one funnel at first, which was soon accompanied by several smaller ones. . . . Finally, one of them seemed to expand and extend downwards more steadily than the

others, resulting at length in what appeared to be their complete absorption."

These are typical examples of general tornado descriptions, all of which indicate wind opposition. Opposite winds seem always to prevail, probably in different strata of the atmosphere, the south wind usually, perhaps always, the lower. This warm and humid south wind naturally rises, while the cold north wind as naturally descends. Thus two strong and opposite air currents, which had been moving in different layers of the atmosphere, meet face to face. The result seems necessarily the same in air as in water, the formation of a vigorous eddy or vortex, whose energy depends upon that of its constituent winds. In this case the escape is upwards, and the descent of the eddy to the ground is probably a consequence of the effort of the winds to pass each other. The opposing air currents have widely extended fronts, more or less angularly inclined to each other, so that they come together gradually, like, to use a homely illustration, the meeting of the blades of shears. To this the progressive movement may be due. The vortex is generated at each successive meeting point of the winds, and vanishes in the rear as it forms in front. Its speed of progression indicates that of meeting of the angular wind fronts, and depends on the width of the angle, while its irregularities are doubtless due to the variations of speed and direction in the winds to which it owes its origin. The final prevalence of the north wind at the surface seems to indicate a reversal of position in the two air currents, the north having descended to a lower, the south ascended to an upper stratum of the atmosphere, so that they once more pass without opposition.

Gen. Greeley's list of destructive tornadoes is given in part in the following table, some of the less destructive being omitted:

State.	Date.	Loss			
		Killed.	Injured.	Houses.	Value.
Miss.	May 7, 1810.	317	109	\$1,200,000
"	June 16, 1842.	500			
Conn.	Aug. 9, 1878.	34	28	2,000,000
Mo.	April 18, 1880.	101	600	...	1,000,000
Iowa.	June 17, 1882.	100	300	260	1,000,000
Miss.	April 22, 1883.	51	200	100	300,000
Wis.	May 18, 1883.	16	100	52	175,000
Minn.	Aug. 21, 1883.	26	80	400	700,000
Ark.	Nov. 21, 1883.	5	162	60	300,000
N. C.	Feb. 19, 1884.	18	125	55	
Dak.	July 28, 1884.	15	18	100	
Wis.	Sept. 9, 1884.	6	75	305	4,000,000
N. J.	Aug. 3, 1885.	6	100	500	500,000
Ohio.	Sept. 8, 1885.	6	100	300	500,000
Minn.	April 14, 1886.	74	136	138	385,000
Ohio.	May 12, 1886.	57	85	
Kan.	April 21, 1887.	20	237	330	1,000,000

Many of these tornadoes extended through several States, that of April 14, 1886, for instance, traveling 350 miles—from Council Bluffs to Sank Rapids, Minn., which town it destroyed. That of April 18, 1880, utterly wrecked the town of Marshfield, Mo. Many other towns and villages have been partly or wholly destroyed, and it seems evident that, in the fuller settlement of the Mississippi Valley States, a greatly increased annual destruction may be expected from this source. The forests of that section often present great lines of broken-down and torn-up trees, indicating the tracks of tornadoes in the past. As towns replace forest and cover the prairie lands, the danger will proportionately increase. The Atlantic States, while less frequently visited by this terrible agent of destruction, are by no means exempt. Several of the examples in the table given were in the East—that of August 3, 1885, passing through the city of Camden, N. J., where it made frightful havoc. A more recent disaster of this kind was that of January 9, 1889, in which a violent tornado struck the city of Reading, Pa., fortunately only on its outskirts, utterly wrecking a silk-mill and a railroad paint-shop, with a loss of 24

killed, 98 injured. This tornado passed over a considerable extent of country, but, by good fortune, struck no other town. What was probably an accompanying tornado passed over Western Pennsylvania on the same day, doing great damage in the oil-fields, blowing down the suspension bridge at Niagara, and wrecking an unfinished building at Pittsburg, with considerable loss of life. (C. M.)

TORTOISE, one of the names given to the *Testudinata*, or shell-bearing reptiles, which See Vol XXII. p. 455 (p. 484 of turtle and terrapin. As at present Am. Rep.) used the tendency is to restrict the title of tortoise to the marine species, that of turtle to the land species, and that of terrapin to fresh water and coast species of the family *Emydidae*. In the United States the name of terrapin is applied only to a few species of this family which are used for food. The United States has in all 42 or 43 species of tortoises, of which all, with the exception of the musk tortoises, are used to a greater or less extent for food, or for other economical purposes. Yet only a few species are in actual demand, including the marine green turtle, 2 or 3 species of soft-shelled turtles, the snapping turtle, the gopher or land-turtle, and 3 or 4 species of terrapin. Of the latter much the most highly prized is the diamond-back salt-water terrapin (*Malacolemys palustris*). This species is found in the salt marshes along the coast from Massachusetts to Texas and also in South America. The northern terrapin, however, are more delicate in flesh than those of the Gulf, and the principal market supply comes from Chesapeake Bay and the coast of the Carolinas. Egg Harbor, N. J., also furnishes some very fine ones.

The diamond-back terrapin is of small size, the under shell of the female averaging 6 or 7 ins. in length, its extreme length being 10 ins. The weight is 4 or 5 lbs., though in extreme cases 10 lbs. is reached. It has a very large head, with strong and cutting jaws, small eyes, and short and thick neck. The shell is oval, moderately convex, and of a dusky olive-green color, with darker concentric lines. The sternum, or lower shell, is yellow, with dusky concentric lines. This species is very shy and active, swims well, and runs with considerable speed on land. The males are smaller than the females, much less valued, and sell at a considerably lower price. The fishing season lasts from Oct. 1 to June 1, October and November being the best months. At this period the terrapin has buried itself deeply in the mud for its winter hibernation, and is very fat and juicy. It is easily found by a mound of mud raised above its hiding-place, and is taken in considerable quantities. The eggs, 25 to 100 in number, are laid in early spring. Females in egg are the most highly valued, the eggs being the tidbit of epicures. In their best season terrapin sell at from \$15 to \$36 and even \$50 per dozen, according to size. The males are used only in soups, and bring about \$3 per dozen. Many terrapins are caught in summer, and penned in "yards" till the market season. They are found to breed in captivity, and efforts have been made, with some success, to raise them from eggs laid under such circumstances. This is important, as the annual catch, never large, is steadily decreasing. Philadelphia is the principal market for terrapin, though large quantities are supplied to other seaboard cities, and many are sent to the cities of the interior.

There are from 15 to 20 species of fresh-water terrapins in the United States. These, formerly classed in the genus *Emys*, but now divided into several genera, differ from the land-turtles in having their feet more webbed and expanded, and the shell of the back more flattened. Three or four species of the genus *Pseudemys* are of marketable value. Of these the red-bellied terrapin, *P. rugosa*, is usually 10 or 11 ins. long. Its upper shell is of a dusky brown color, with blotches and lines of red; the lower shell is of a dusky

red hue. It dwells only in the Delaware and Susquehanna and the rivers of Chesapeake Bay. The flesh is very palatable, and it is gathered in considerable numbers for market, being largely substituted for the diamond-back in restaurants.

Yet more esteemed is the yellow-bellied terrapin, *P. scabra*, which is found in stagnant ponds from Virginia to Florida, and is abundant in the latitude of Charleston. It is about 12 ins. long, $7\frac{1}{2}$ wide, and 11 high, the upper shell being very convex, and deeply serrated behind. It is of blackish-brown hue, with radiating yellow lines and marks, the sternum being yellow. These species feed on small reptiles, fish, etc., and will eat vegetable food in captivity. Out of water they move more quickly than the land-turtles. Farther south occurs another species of value, the Mobilianer (*P. Mobiliensis*). This is the largest of the food species, the shell being often 14 to 16 ins. long by 10 wide, and $7\frac{1}{4}$ high. In color it is brownish, with yellow lines and bands, while the sternum is pale yellow. It is found in lakes and rivers from North Carolina to Western Louisiana, and up the Mississippi to Arkansas, and is very abundant in East Florida, especially in the St. John's River. The flesh is quite delicate, and is much esteemed in the Southern cities.

The chicken terrapin, *Chrysemys reticulata*, is about 9 by 5 in. in dimensions, the color of its upper shell being dark brown with a network of yellow lines, that of the lower yellow. Its long neck, as it swims with body hid and head extended, presents a snake-like appearance. It occurs from North Carolina to Louisiana, and is the most esteemed of the fresh-water terrapins. *C. picta*, a somewhat smaller species, is also valued as food.

Other species of tortoises are used as food in the United States. Of marine tortoises the only species of value is *Chelonia viridis*, the green turtle, which is used extensively as the basis of turtle soup. The Pacific coast has a related species, *C. virgata*. Of what are known as soft-shelled tortoises the United States has 6 species, belonging to 2 genera, which differ in length from 6 in. to 2 ft. or more, and in weight from 4 to 16 lbs. These occur in most of our lakes and rivers, from the Atlantic to the Rocky Mountains, and are easily taken by hook and line, as they bite greedily. Their flesh is a superior article of food, surpassing in delicacy, it is said, the green turtle. Their eggs also are considered excellent.

Of the snapping turtles there are two species, belonging to different genera. The northern species, *Chelydra serpentina*, is widely distributed, and is largely taken for food purposes. Its maximum weight is 20 to 30 lbs. The Southern species, known as the alligator turtle, weighs 50 or 60 lbs. and in extreme weight 100 lbs. It is spoken of very highly as a food species, some stating that it is more delicate than the green turtle, though this is doubtful. The gopher, the great land-turtle of the South, is also used to some extent as food. This species is 15 in. long and is so strong that it can move under a weight of 200 lbs. It lives in underground burrows in the sandy forests of the Gulf States. Even the little "box turtle," the familiar inmate of our fields and gardens, is occasionally eaten, and is said to be quite palatable when fat. (C. M.)

TOTTEN, JOSEPH GILBERT (1788-1864), chief-engineer U. S. A., was born at New Haven, Conn., Aug. 23, 1788. He graduated at West Point in 1805, and being commissioned second-lieutenant in the engineers' corps went as assistant to his uncle, Jared Mansfield, surveyor-general of Ohio. Although he resigned from the army he soon returned and was engaged in the construction of forts in New York harbor until the commencement of the war of 1812. Then he was made chief-engineer of the army on the Niagara frontier and fought at Queenstown. Afterwards he served at Lake Champlain and was brevetted lieutenant-colonel for his gallantry at the battle of Platts-

burg. In 1816 a Board of Engineers was formed to devise a system of coast defence, and in connection with this work Totten rendered most important service to his country. In 1819, when Gen. Simon Bernard was brought from France to give the benefit of his long experience in this branch of warfare, the other members of the board resigned, but Major Totten continued, and the reports prepared on harbor and coast defence were mostly from his pen. In 1825 Totten (now brevet colonel) began the construction of Fort Adams at Newport and was thus engaged for thirteen years. In 1831 Gen. Bernard retired and Totten had charge of the harbor defences east of New York. In 1838 he published *Hydraulic and Common Mortars*, giving the result of many experiments by himself and others. In the same year he was made chief-engineer with the rank of colonel, and removed to Washington. He continued to carry out his plans of coast defence until 1847, when he was called by Gen. Winfield Scott to take charge of the engineering operations in the siege of Vera Cruz. After the capture of the city he returned to Washington, having obtained the brevet of brigadier-general for his services. Besides his office work at Washington, he made a biennial tour of inspection, examining every detail of construction in the forts and other defences. He was also a member of the Light-House Board from its organization in 1852, and was actively connected with various scientific associations. When Gen. Scott was obliged to retire from the chief command of the army, he suggested Gen. Totten as his successor, but the latter declined on account of his own advanced age. He died at Washington, April 22, 1864, having received a brevet as major-general on the previous day. Among his *Reports* may be mentioned those on *National Defences* (1851) and *Ordnance* (1857). Although the fortifications to whose construction his energies were given have been proved insufficient owing to the vast changes in ordnance, there has been no system devised to take their place which meets universal approval.

TOURGEE, ALBION WINEGAR, author, was born at Williamsfield, Ohio, May 2, 1838. He prepared for college at Kingsville Academy and entered Rochester University as sophomore in 1859. He was one of the first to volunteer for service in the Union army, enlisting April 17, 1861, as a private in the Twenty-seventh N. Y. volunteers. He was wounded at the first battle of Bull Run and discharged, but the following year was commissioned first-lieutenant, by Gov. Tod, of Ohio, and recruited Company G, One-hundred-and-fifth Ohio V. I. He resigned his commission in 1864 on account of wounds and disease contracted in Salisbury and Libby prisons. He was married to Emma L. Kilbourne, of Conneaut, Ohio, in 1863, and at the close of the war settled in Greensboro, N. C., as lawyer and editor. He was a delegate to the Southern Loyalist Convention held in Philadelphia in 1866, and was a member of the committee that drew up the report on the condition of the Southern States. He was elected to the constitutional convention of North Carolina in 1868, and took so prominent a part in this body that the constitution then prepared is often called "Tourgee's constitution." He was appointed by this convention one of the three commissioners to codify the laws of the State. He was elected judge of the Superior Court in 1868, which office he held until the expiration of his term, in 1874. He was also a member of the State constitutional convention of 1875. He is the author of the *N. C. Form Book*; *The N. C. Code with Notes*, and a *Digest of Cited Cases*. Besides these legal works he is the author of the following works of fiction: *Soinette* (1874; in later editions *A Royal Gentleman*); *Figs and Thistles* (1879), a romance partly founded on Pres. Garfield's army career; *A Fool's Errand* (1879), a work that attracted much attention and has been translated into several languages. It is a graphic exposure of the difficulties

which Northern men and women encountered in attempting to settle in the South after the war. To it was afterwards added an appendix, "The Invisible Empire." To the same class belong his *Bricks without Struc* (1880); *John Eric and Mamelon* (1882); *Hot Plowshares* (1883); *An Appeal to Cæsar* (1884); Cæsar here denoting the sovereign American people; *The Veteran and his Pipe* (1886); *Button's Ian* (1887), a story relating to the early days of Mormonism in Ohio; *Black Ice and Letters to a King* (1888). From 1882 to 1884 Judge Tourgee was editor of *Our Continent*, a weekly magazine, published in Philadelphia. No man has contributed more to the political education of our people than Judge Tourgee. Original in method, fearless in expression, and graphic in style he has pressed home to the hearts and consciences of the American people the difficult political and social problems of his generation. His present residence is at Mayville, Chautauqua co., N. Y., where he employs himself solely in literary pursuits.

TRADE, BOARDS OF. These are combinations of merchants, manufacturers, and others to promote the interests of commerce, external and internal, and in every way to aid the industrial advancement of cities and nations. The first idea of concerted action for this purpose seems to be due to Cromwell, who in 1655 appointed his son Richard, many lords of his council, judges and gentlemen, and about twenty merchants of London, York, Newcastle, Yarmouth, Dover, etc., to meet and consider how the trade and navigation of the Commonwealth might be best promoted. After the Restoration, in 1660, Charles II. established a council of trade to control all the commercial interests of the nation, and afterwards instituted a Board of Trade and Plantations. This board, after being remodelled by William III., continued in existence till 1782, when it was abolished, and a new council for the regulation of trade affairs, on the plan still existing, was appointed Sept. 2, 1786. See **TRADE, BOARD OF**, in the **ENCYCLOPÆDIA BRITANNICA**.

Apart from this governmental board, the merchants of many cities, both in Europe and in the United States, have organized civic Boards of Trade, or Chambers of Commerce as they are called in some cases, whose deliberations have taken a wide scope and proved of the utmost benefit to commercial interests at large. At their meetings every subject relating to the material interests of cities and nations is debated, the mature judgment of the members brought to bear on the problem, and resolutions taken in accordance with the opinions of those best adapted by their experience to offer wise and pertinent suggestions.

The earliest American movement in this direction was made April 5, 1768, on which date twenty merchants of New York organized themselves into the Chamber of Commerce of that city, for the expressed purpose of the promotion and encouragement of commerce, of adjusting disputes relative to trade and navigation, supporting industry, obtaining necessary legislation, and doing everything in their power in the interest of commerce. This association is still in existence, the only one dating from the last century with the exception of the New Haven Chamber of Commerce, organized in 1791. No similar institution was organized till 1833, when the Philadelphia Board of Trade was established, composed of persons interested in commerce, finance, manufacturing, and the mechanic arts; its object being the promotion of the trade of the city, the improvement of facilities for transportation, and the use of all proper measures for advancing the interests of the business community.

The idea thus instituted by the leading cities of the country was adopted by others in gradual succession: by Cincinnati in 1839, Buffalo in 1844, Chicago in 1848, Baltimore in 1849, San Francisco in 1850, Portland in 1853, Boston in 1854, Detroit in 1856, Milwaukee in 1858, St. Louis in 1866, and others of the smaller cities at various intermediate and later periods.

In 1868 a new idea was put into effect, in the formation of a National Board of Trade, composed of delegates from the associations of the several cities, the first meeting of which was held at Philadelphia in June of that year. It was composed of delegates from the following organizations: the Boards of Trade of Albany, Baltimore, Boston, Buffalo, Charleston, Cleveland, Denver, Detroit, Louisville, Newark, Oswego, Philadelphia, Pittsburg, Portland, Providence, St. Louis, Toledo, Troy, and Wilmington (Del.); the Chambers of Commerce of Cincinnati, Milwaukee, New Orleans, New York, Richmond, and St. Paul; the Boston Corn Exchange, Dubuque Produce Exchange, New York Produce Exchange, Peoria Merchants' Exchange, Philadelphia Commercial Exchange, and St. Louis Union Merchants' Exchange. Its purpose, as stated in its articles of organization, was to promote the efficiency and extend the usefulness of the various Boards of Trade, Chambers of Commerce, etc., organize for general commercial purposes, to secure unity and harmony of action in commercial usage, custom, and law, and to consider all questions pertaining to finance, commerce, and the industrial interests of the country.

This national organization has met annually in different cities of the country, its meetings from 1879 to 1888 having been held at Washington. Frederick Fraley, of Philadelphia, its first president, has presided over every successive meeting, and was re-elected at the meeting held in 1888 at Washington, at which meeting 21 societies were represented. On Nov. 14, 1888, a meeting was convened at Chicago. In regard to the general scope of interests considered at the meetings of the National Board of Trade, it may perhaps best be shown by naming those debated at the 1888 meeting. These included the subjects of adulterations, coast defenses, river and harbor improvements, postal telegraph, agricultural reports, revenue, trade reciprocity with Canada, bankrupt legislation, naturalization laws, national bankruptcy law, currency, questions of shipping, pilotage and quarantine, etc.

The meetings of the city associations consider questions relating principally to local interests, but the annual deliberations of so many bodies composed of the most experienced business men of our various cities, and of a national board made up of selected delegates from the local boards, cannot but be of the utmost benefit to the commercial and industrial interests of the country, and go far towards the solving of many mooted questions in social and political economy and the promotion of the welfare of mankind in general. The great growth of modern business and the diversity of interests involved has necessitated the formation in many cities of associations devoted to the promotion of particular interests, such as corn exchanges, produce exchanges, and the like, more restricted in their interests than the general boards of trade, yet working in harmony with them. Some examples have already been named, and there may be added, as secondary to the old-established New York Chamber of Commerce, the New York Importers' and Brokers' Board of Trade (1872), and the New York Board of Trade (1874). (c. m.)

TREASON. The crime of treason has in the United States undergone changes in its constitution from its character as prevailing in England that are characteristic of the difference between governments that have a purely popular basis and those that rest wholly or partly upon the derivation of public authority by heredity. The government of Great Britain is popular only as it regards one of the branches of its legislature, while the Crown and Lords, constituting the other two branches, still claim their public functions through heredity. The Crown of Great Britain still preserves attributes common to monarchies absolute and limited that give to the act of treason a personal character in its bearing upon the personal

See Vol. XXIII. its constitution from its character as prevailing in England that are characteristic of the difference between governments that have a purely popular basis and those that rest wholly or partly upon the derivation of public authority by heredity. The government of Great Britain is popular only as it regards one of the branches of its legislature, while the Crown and Lords, constituting the other two branches, still claim their public functions through heredity. The Crown of Great Britain still preserves attributes common to monarchies absolute and limited that give to the act of treason a personal character in its bearing upon the personal

See Vol. XXIII. its constitution from its character as prevailing in England that are characteristic of the difference between governments that have a purely popular basis and those that rest wholly or partly upon the derivation of public authority by heredity. The government of Great Britain is popular only as it regards one of the branches of its legislature, while the Crown and Lords, constituting the other two branches, still claim their public functions through heredity. The Crown of Great Britain still preserves attributes common to monarchies absolute and limited that give to the act of treason a personal character in its bearing upon the personal

sovereign. Hence in England to compass the death of the occupant of the throne, as the lawyers express it, is an act of treason. In the United States the sovereignty resides in the public as a community, and an act of treason is necessarily one against the entire community. To this idea the Constitution of the United States is conformed, since it declares that treason against the United States shall consist only in levying war against them, or in adhering to their enemies, giving them aid and comfort. It is possible for a single person to do all that need be done to take the life of the personal sovereign, but to antagonize the government of a community implies means of a very different nature.

The definition given to treason, as used in the Constitution, and accepted as authoritative, is that it implies the assembling of a body of men for the purpose of overturning or resisting the government by force, and the performance of some act looking to that end, although such act need not amount to a collision of arms. This definition is in harmony with the spirit of popular institutions, for it accords with the popular right to deliberate together and plan changes of the government or of its policies, general or particular, so long as force is not to be the instrument for the accomplishment of that purpose. That which the whole people have a right to accomplish can be undertaken by any limited portion of the whole number if force is not resorted to. An assembly for deliberative purposes alone is not an act of war, for though war may be the product of deliberation, it represents a distinct step beyond that of deliberation. The act of war is recognized as a corporate act in which more than one must be engaged, although the minimum number has not been agreed upon, but according to the judicial interpretation a maximum is not necessary that could be supposed sufficient to accomplish the end intended.

The assembly, in order to fall under the censure of the law, must be to act rather than to deliberate, and that action must be directed against the authority of the government, using force as its intended instrument. To resist a subordinate officer of a government is not that kind of resistance that is contemplated by the Constitution, unless an intention accompanies it to meet the whole force of the government, should it be brought into exercise. An instance of this class appears in the case of the Whiskey rebellion in Pennsylvania, where force was directed against the judicial power of the government.

According to the European system, from which our own is derived, the effect of treason upon an individual convicted of it is to deprive such person of all civil and political right in addition to deprivation of life. His capacity both of holding property and of transmitting it to others by descent is taken away. This result might not only ensue as the consequence of conviction of such crime, but might be produced by an act of legislation. The Constitution of the United States precludes this consequence and leaves the civil consequences of treason to be applied through a conviction by the judicial authority. The laws of the United States go a step farther and limit these civil consequences to the life of the person convicted as it regards the disposition of property at death.

In 1790 the crime of treason was defined by Congress in harmony with the provision of the Constitution. No other legislation on that crime appears to have taken place until the rebellion of 1861, which called forth in the following year provisions of law of a more definite character than had previously existed.

The history of the United States presents some striking instances of treasonable conduct. The treason of Gen. Arnold during the Revolutionary war was an important military fact, but gave rise to no legislative or judicial consequences. The most notable event of that class occurring in the first half of the century of our national existence was the attempted invasion of Mexico by a force raised to carry out the plans of

Aaron Burr, while the last half of that century is signalized by the attempt of several States of the Union to secede therefrom. The former was an effort to take advantage of the divergence of interests between the Atlantic States and those bordering on the Mississippi River, while the latter instance was an effort that arose from differences of interests and sentiment between States bordering on the Atlantic. Kentucky and Tennessee were the first among the group of States that depend upon the great waterway afforded by the Mississippi River, which before the days of railroads was the only avenue of commerce upon which the vast region embracing the interior of this continent could rely where not touching on the Great Lakes. The soil and jurisdiction of Kentucky were claimed by Virginia, and those of Tennessee by North Carolina. The people of these colonies claimed their independence of those States, and persisted in these claims until time and immigration established their claims. This conflict of jurisdiction sowed the seeds of discontent and alienated the interests and affections of the respective peoples. The Atlantic States were connected together by common interests of navigation in which the Western States did not participate, while the commercial advantages afforded by the Mississippi River appeared to be disconnected from those affecting the Atlantic States. While the west bank of the Mississippi was controlled by France, then under the authority of Napoleon, Mexico and Florida, held by the Spanish, lay at the outlet of that river. The purchase of Louisiana in part satisfied the demands of the people of the valley of the Mississippi, but Spain desired still to hold the advantages of the trade of that river. Taking advantage of this disturbed condition of popular feeling and interest and of the unsettled policy of the Western States, Burr devised a scheme of taking forcible possession of the Spanish territories. Many believed that his plan was to bring about disunion as an ultimate consequence of his bold enterprise, and this impression had doubtless much to do with the activity that counteracted his plans. That Burr appealed to the discontent of the people of the West and excited among them a desire to advance their local interests by a striking adventure although in disregard of their allegiance to the Union, may be assumed. Places of assembling troops and storing military supplies were established, and men and supplies collected, but the vigilance of the government prevented such secrecy and deliberate preparation as was necessary for the consummation of his plans. Burr hastily embarked with a small body of men to descend the Mississippi, hoping to increase his force as he advanced. In this he was disappointed, as the enterprise was broken up by the action of the government before he reached New Orleans, and he sought to escape but was captured and made a prisoner in Alabama. Taken to Richmond, he was there indicted, with several of his associates, for treason and misdemeanor. His trial resulted in his acquittal of both offences.

If what Burr intended had been consummated it would have been an act of war against a friendly power, but such an act would not necessarily involve treason against the United States. Assembling troops within the United States for such a purpose, although contrary to its laws, would not necessarily imply that those troops were intended to come into collision with the civil or military power of the United States. Such a collision might occur, and in fact was likely to occur, but it would only be when the expeditionary force was confronted by the authority of the United States that the intention directing it could be brought to a test. The intention that constitutes treason a crime must be evidenced by some overt act, and such act could only appear in the presence of some exercise of governmental authority adverse to the plans of the expedition. Had its direct object been to oppose force to the authority of the government a different case would have existed, but such an intention was not to be presumed

in the present case; if there was a covert design to use force against the authority of the government that fact could only be disclosed when suitable circumstances brought it to light.

If Burr's ultimate intention embraced disunion of the States as a consequence of a turn of affairs growing out of the attack upon Mexico, that expectation could not enter into the question of treason as connected with the early stages of the movement, for that would depend upon the drift of events rather than upon a concerted scheme of action. Burr's enterprise is distinguishable from others that have since that time occurred by the magnitude of the intended plan and the power of the man both personally and as derived from his having held the office of Vice-President of the United States.

The rebellion of 1861 presents marked instances of treason. It was brought about by persons owing allegiance to the United States although disclaiming that fact, and the first important act was an attack by armed bodies of men upon the military force of the United States. Whatever may have been the actual or assumed grounds of this act of war, in its legal character it was an act of treason. Elaborate legislation by Congress was called out by the resistance offered to the government. In its relation to the question of treason the stage of hostilities should be divided into two parts, the one prior to the recognition by Congress of the existence of a state of war between the opposing forces, and the other after such recognition had taken place. Congress was the only power that could declare war under the Constitution, and until such declaration was made the individuals engaged in rebellion could only be regarded as personally responsible for their conduct inimical to the government. The fact that other powers might recognize the Confederate States as entitled to the character of belligerency could not change the question as it regarded the fact of citizens of the United States making war against that power, for the action of foreign powers could not produce any change in the domestic effect of the laws of the United States.

When Congress declared the state of war to exist it did so because it found that the hostile forces were under the control of a government that had secured actual control over the people of the section engaged in rebellion. That declaration announced that the action of the United States would be against such government and not against the individuals of which it was composed. The hostile conduct of the people of that region became merged in that of the government which had obtained control of them and the arbitrament of war displaced that of civil judicature. But although the recognition of the state of war properly suspended civil functions acting in the same sphere to deal with questions of that character, yet at the conclusion of the war the responsibility for all acts of hostility committed before the declaration of war was revived, and legally the penalties for treason might have been imposed. But there is a cause that tends to modify the strictness of the law in cases of the class under consideration, and that is a humane sentiment that has obtained great force among civilized peoples that operates against the infliction of individual penalties in cases where popular commotion has eventuated in organized armed resistance to the public authority. It was this sentiment prevailing at the close of the rebellion that resisted attempts to enter upon any general policy of prosecuting for acts of treason committed during those stages of the conflict where the penalties for treason were appropriate.

It would not be a just criticism upon the leniency of the government at the close of the war to charge it with weakness in not vindicating the right of government and marking the duty of the citizen by imposing penalties for acts of treason committed, for the sentiment that induced such leniency was a cause of a nature recognized in all systems of jurisprudence as

appropriate to modify the conduct of the administration of justice.

The fact that in the short existence of this nation so many instances have occurred in which treason, actual or incipient, has been applied against this government is not an evidence that the attachment of the people to their government is less than in countries where a more rigid régime exists, but is the natural consequence of the fact that the susceptibility of our governmental forms to change arising from popular causes induces that liberty to run out into excesses in that direction. A more mature experience will lead to a more distinct discrimination between legitimate and improper means of inducing change in the structure and administration of the government.

(A. J. W.)

TREASURY. The U. S. Treasury Department was originally established by act of Congress of Sept. 2, 1789, and numerous amendments and enactments have since so augmented its business and proportions that it is now the largest and most important of all the executive departments of the United States government. It is presided over by a Secretary, who is appointed by the President and confirmed by the Senate. Upon this officer devolves the duty of digesting and preparing plans for the improvement and management of the revenue and for the support of the public credit. He is required to superintend the collection of the revenue; to prescribe forms for keeping and rendering the public accounts, and of making returns; to make reports annually, and specially when called upon, and to give information to either branch of Congress, in person or in writing as may be required, respecting matters referred to him, and as to all matters pertaining to his department; to grant, under the limitations established by law, all warrants for moneys to be drawn from the treasury in pursuance of appropriations made by Congress; and generally to perform all such duties connected with the national finances as are required by law. The functions of this officer and the multifarious business intrusted to his supervision have been greatly expanded within the past quarter of a century. These, as may be imagined from a contemplation of the vast interests and resources of the country, are numerous, and, among others, embrace the management of the public debt, the national currency and coinage, the supervision of the national banks, the control and management of matters pertaining to the internal revenue system, the customs service, the commercial marine, the light-house and buoyage system of the country, the survey of the coast and interior triangulation of the United States, the construction of public buildings under control of the department, the collection of commercial statistics, the inspection of steam-vessels, the marine hospital service, the life-saving service, and the prevention and detection of fraud upon the revenue.

Two assistant-secretaries of the treasury are also appointed by the President and confirmed by the Senate, either of whom may be designated as acting-secretary during the absence or inability of the secretary. There are also in the office of the secretary a chief clerk and nine division chiefs, upon whom, under the general supervision of the secretary and assistant-secretaries, devolves the general direction of the routine business and operations of the office. In addition to the officers connected with the secretary's office proper there are in the department a first and second comptroller, a commissioner of customs, and six auditors, who constitute what are known as the accounting officers of the treasury. These officers are also appointed by the President and confirmed by the Senate, and hold office until the appointment of their successors. All accounts for the receipt and expenditure of public moneys are subject to the examination and settlement of these officers, as the same come respectively within the provision assigned to each by the statutes. Their official duties, as may readily be imagined, are of vast

magnitude, responsibility, and importance. There is required of them, in the discharge of those duties, not the capacity of the accountant alone, but of a mind trained to and adapted for administrative and judicial investigation. Those duties embrace the examination of facts, the sifting of evidence, the determination of conflicting claims and adverse interests, as well as the construction of statutes and the application of settled and well-defined principles of law.

The auditor provided for by the act creating the department, was then known as auditor of the treasury. His duties were to receive and audit all accounts. Subsequently, by the act of March 3, 1817, four additional auditors were provided for, and he was then denominated the first auditor. He is required by law to examine all accounts relating to the receipts from customs; all accounts accruing in any department on account of salaries; all accounts for salaries and expenses of judges, marshals, and other officers of United States courts; expenses connected with the construction of public buildings; and generally all accounts relating to the civil expenses of the government with the exception of those incurred in the consular and diplomatic service and internal revenue bureau. Early in this century such a distribution of the public business was demanded as was calculated to result in a prompt settlement of public accounts. Hence the necessity for the act of March 3, 1817, which provided for five auditors, to whom were assigned, respectively, the settlement of the accounts of the different departments. The duties of the second auditor, as now defined, are the examination and settlement of accounts relating to the pay and clothing of the army, ordnance service, subsistence of officers, bounties to soldiers, hospital stores, and contingent expenses of the war department, and of all accounts relating to Indian affairs. The third auditor is required to examine all accounts relative to the subsistence and transportation of the army, and generally all accounts of the war department other than those assigned by law to the second auditor, and all accounts relating to army pensions. The fourth auditor receives and settles all accounts relating to navy pensions, and accounts pertaining to the naval service. The fifth auditor receives and examines accounts accruing in or relative to the diplomatic and consular service; accounts relating to the census, the National Museum, and the contingent expenses of the patent office. The office of the sixth auditor was originally created by the act of July 2, 1836. Previously the duties had devolved on the fifth auditor in addition to his other duties. The duties of the sixth auditor bear relation both to the Treasury and Post-Office departments. He is an officer of the treasury, and under the direct control of the secretary, but, at the same time, he is also by law subject in certain respects to instructions which may be given by the Postmaster-General. He is required by law to examine all accounts relating to the postal service, and to report to the Postmaster-General all balances found on settlement of such accounts. Unlike the other auditors, his settlements of accounts are not subject to revision by any other officer, except when dissatisfaction is expressed by any person or by the Postmaster-General, in which case an appeal may be taken within twelve months to the first comptroller, whose decision is final. All the accounts passed upon by the other five auditors go to the first or second comptroller or commissioner of customs for re-examination. All returns relative to the survey and sale of public lands are made to the commissioner of the General Land Office in the Interior department, who is required by law to audit and settle all public accounts relative thereto, and to certify the balances and transmit the accounts to the first comptroller of the treasury for his examination and decision. He is thus made an auditing officer, with duties relating to accounts pertaining to public lands or of like character as those devolving on the auditors of the treasury, with regard to their several subjects of accounting.

The first comptroller is required to examine all accounts settled by the first auditor except those relating to receipts from customs; all accounts settled by the fifth auditor and by the commissioner of the general land office, and to certify to balances arising thereon to the register of the treasury. He is also required to countersign all warrants drawn by the Secretary of the Treasury which are authorized by law, and to superintend the recovery of all debts certified by him to be due the United States, and for that purpose to direct such legal proceedings as may be adapted to enforce prompt payment thereof. The second comptroller examines all accounts settled by the second, third, and fourth auditors, and certifies the balances arising thereon to the heads of the departments in which the expenditures have been incurred. He also countersigns all requisitions drawn on the Secretary of the Treasury by the Secretaries of War and of the Navy.

The office of commissioner of customs was created by the act of March 3, 1849. At this time there were two revising officers, already described as first and second comptrollers, the former of which was charged with the duties transferred by that act to and now performed by the commissioner of customs. He is required by law to examine all accounts settled by the first auditor relating to the receipts from customs, and to certify to balances arising thereon to the register of the treasury. In addition to the foregoing there are also embraced in the organization of the department the following-named officers: Treasurer of the United States; Register of the Treasury; Commissioner of Internal Revenue; Comptroller of the Currency; Director of the mint; Chief of the Bureau of Engraving and Printing; Supervising Inspector-General of the Marine Hospital establishment; Supervising Inspector-General of Steamboats; General Superintendent of the Life-Saving Service; Superintendent of the Coast and Geodetic Survey; Chief of the Bureau of Commercial Statistics; Supervising Architect; Commissioner of Navigation; Chief of the Secret Service; and the Light-House Board.

Persons appointed to the office of Secretary of the Treasury, first comptroller, first auditor, treasurer, or register, are prohibited by law from being concerned or interested in trade or commerce, public lands or other public property, or public securities of a State, or of the United States, and from taking to his own use any emolument or gain for negotiating or transacting any business in the treasury department other than is allowed by law. The duties of the register are to keep all accounts of the receipts and expenditures of the public money, and of all debts due to or from the government; to receive from the first comptroller and commissioner of customs all accounts finally adjusted by them, and to transmit to the Secretary of the Treasury copies of the balances of accounts so certified; to record all warrants for the receipt of payment of moneys at the treasury, except those drawn by the Postmaster-General and those by the Secretary of the Treasury upon requisition of the Secretaries of War and of the Navy. This officer also has charge of the accounts of the issue and redemption of bonds, notes, and other securities of the United States, and is custodian of the records and files pertaining to the accounts arising in the civil branches of the government. The office of Treasurer of the United States was created by the act establishing the Treasury department. The treasurer is required to give bond in the penalty of \$150,000, conditioned for the faithful discharge of his office, and for the fidelity of the persons to be employed under him. He receives and keeps the moneys of the United States, and disburses them only upon warrants drawn by the Secretary of the Treasury. He is also charged with the custody of all public moneys deposited in the various sub-treasuries and depositories throughout the country; he receives from the Bureau of engraving and printing, and counts and seals preparatory to use, United States

legal tender notes for the reserve fund kept on hand to replace worn and mutilated notes of the same character which are from time to time redeemed and retired from circulation; he acts as agent for the redemption of national bank notes; has entire charge of the payment of interest on the public debt; is custodian of bonds held in trust for various tribes of Indians, and of bonds purchased from time to time by the Secretary of the Treasury, as trustee of the sinking-fund established by law for the liquidation of the debts due the government from the Union Pacific and Central Pacific Railway Companies, and is charged generally with the safe-keeping of all public funds. The commissioner of internal revenue, under the direction of the Secretary of the Treasury, is invested with the general superintendence of the assessment and collection of internal revenue taxes, embracing the preparation and distribution of all instructions, regulations, forms, blanks, stamps, and other matters pertaining thereto.

The office of comptroller of the currency was created by the national banking act of 1864. The comptroller is charged, under the general direction of the Secretary of the Treasury, with the execution of all laws relating to the issue of a national currency secured by U. S. bonds. He is appointed by the President on the recommendation of the Secretary of the Treasury, by and with the consent of the Senate, and holds office for a term of five years, unless sooner removed by the President. He is assisted by a deputy, who has the power and performs the functions and duties of the comptroller in case of a vacancy in the office or during the absence of the comptroller. Both officers give bond for the faithful discharge of their duties, and are prohibited by law from being interested in any association issuing national currency. The comptroller is required to make an annual report to Congress upon the condition, resources, and liabilities of national banks, and upon all matters relating to banking institutions generally. The Director of the Mint is the head of a bureau of the treasury having charge of all U. S. mints and assay offices. He receives his appointment from the President and holds office for a term of five years, unless sooner removed. He is required to make an annual report at the close of each fiscal year, and from time to time such additional reports, setting forth the operations and condition of these institutions, as the Secretary of the Treasury may require. The Bureau of Engraving and Printing grew out of the necessity for the issue of paper currency to meet the demands on the government in the early part of the war of the rebellion, and has since attained such excellence that its work rivals in artistic merit all former productions of like character. The chief of the bureau is charged with the duty of the engraving and printing of all U. S. bonds, legal tender notes, national bank notes, gold, silver, and currency certificates, certificates of deposit, interest checks, disbursing officers' checks, and internal revenue stamps.

The supervising surgeon-general of the marine hospital service (see MARINE HOSPITAL) is charged with the supervision of all matters connected with the marine hospital service, and with the disbursement of the fund for the relief of sick and disabled seamen employed on the vessels of the mercantile marine of the oceans, lakes, and rivers, and of the revenue cutter service, the general superintendence of the marine hospitals, the purveying of supplies, the orders, details, and assignment of medical officers, and the examination of property returns. The supervising inspector-general of steamboats administers the laws relating to the inspection of vessels, and is aided in the work by a board of supervising inspectors and a corps of local inspectors established at the different ports of the country. Inspection is made of hulls and boilers of all vessels engaged in the transportation of goods and passengers.

The LIFE-SAVING SERVICE (q. v.) is under the

charge of a general superintendent. His duties embrace the establishment of life-saving and life-boat stations and houses of refuge at proper points along the coast, for affording aid to shipwrecked vessels thereon, and measures generally calculated to promote the humane purposes of the law; also the selection of sites for the stations and houses of refuge; the preparation of plans and specifications for buildings; the making of contracts for their construction; the testing, erection, and purchase of their apparatus, equipment, and supplies; the organization of the service, and the preparation of regulations for the government of its officers and employes; the employment of crews of experienced surfmen, and the regulation of their wages and duties; the supervision of all expenditures and accounts connected with the service, and the preparation of estimates for its support. They also embrace the award of medals for the saving of life from the perils of the sea; the collection of statistics of marine disasters; the investigation of circumstances attending shipwrecks, and the preparation of the annual report of the operations of the service.

The office of the COAST AND GEODETIC SURVEY (q. v.), like the Light-House Board, because of its close connection in its labors and purposes with the interests of commerce and navigation, has become by process of time attached to this department. The service was originally provided for by the act of Feb. 10, 1807, authorizing the President to cause a survey to be made of the coasts of the United States. The act of March 3, 1843, provided for the organization of a board to adopt a plan of reorganizing the mode of executing the survey, and authorized the employment of as many of the officers of the army and navy as might be found compatible with the successful prosecution of the work, the officers of the navy to be employed on the hydrographical parts and those of the army on the topographical parts of the work. The results of the surveys of the coasts, and of the labors and observations incident thereto, are exhibited in maps and charts prepared and engraved by skilful draughtsmen and engravers employed for this special purpose and in the annual reports to Congress. The general operations of the bureau are at present directed by a superintendent appointed from civil life.

The duties of the chief of the Bureau of Statistics are to collect, arrange, and classify statistical information showing the condition of the agriculture, manufactures, and domestic trade of the several States and Territories. He is required to report annually on the statistics of commerce and navigation of the United States with foreign countries, and publish annually, quarterly, monthly, and occasional reports embodying information relating to imports and exports, immigration, shipping, and other matters relating to the foreign and domestic trade of the country. The supervising architect of the treasury prepares plans and designs for custom-houses, court-houses, post-offices, sub-treasuries, mints, appraisers' stores, warehouses, and all other public buildings under the control of the department, and supervises their construction and repair. The Bureau of Navigation was created by the act of July 5, 1884, and placed under the immediate control of a commissioner of navigation, who is charged with the general superintendence of the commercial marine and merchant seamen of the United States, so far as vessels and seamen are not subject to the supervision of any other officer of the government. He is required to decide all questions relating to the issue of registers, enrolments, and licenses of vessels, and to the filing and preservation of those documents. He is charged with the supervision of the laws relating to the admeasurement of vessels, and the assignment of signal letters thereto, and of determining all questions growing out of the execution of the laws relating to the service and those relating to the collection of tonnage tax. He is also required to prepare and publish annually a list of the steam and

sailing vessels of the United States belonging to the commercial marine, specifying their names, rig, tonnage, home port, and place and date of building, and to investigate the operations of the navigation laws and report to the Secretary of the Treasury any needed amendments thereto.

The chief of division of special agents is charged with the supervision and enforcement of the regulations for the prevention of smuggling and frauds on the customs revenue; the supervision over customs districts and over the acts of customs officers and their books and records, with a view of securing uniformity in their methods of transacting business; the supervision of the transportation of merchandise in bond, and the investigation of cases arising from alleged irregularities in connection with such transportation, and the enforcement of the laws and regulations relating to the establishment of bonded routes and mode of transportation. The principal duties of the chief of the secret service division of the department are to detect and to bring to trial persons engaged in counterfeiting the coin, currency, and securities of the United States, and those engaged in passing or dealing in the same, as well as to detect other felonies committed against the laws of the United States relating to the pay and bounty laws.

The Light-House Board is composed of two officers of the navy of high rank, two officers of the corps of engineers of the army, and two civilians of high scientific attainments, together with an officer of the navy and an officer of engineers of the army as secretaries, all of whom are appointed by the President. Under the superintendence of the Secretary of the Treasury the board is required to discharge all administrative duties relating to the construction, illumination, inspection, and superintendence of light-houses, light-vessels, beacons, buoys, and their appendages, embracing the scenery of foundations of works already existing, the purchasing of illuminating and other apparatus, supplies, and materials of all kinds for building and for rebuilding, and the keeping in good repair the light-houses, light-vessels, beacons, and buoys of the United States. It is required also to take charge and custody of all the archives, books, documents, drawings, models, and other property appertaining to the light-house establishment. (See LIGHT-HOUSE.)

The office of solicitor of the treasury was established by act of May 29, 1830. Previously there had been an agent of the treasury whose duty comprised the collection of official balances due by delinquent officers of the government and of other debts due the United States. In addition to the duties which devolved upon this agent the solicitor is required to take cognizance of all frauds or attempted frauds upon the revenue, and to exercise a general supervision over the measures for their prevention and detection, and for the prosecution of persons charged with the commission thereof. It is his duty also to establish such regulations for the observance of collectors of customs and of officers of U. S. courts respecting suits in which the United States is a party, as may be necessary for the just responsibility of those officers and the prompt collection of all revenues and debts due and accruing to the government, excepting those arising under the internal revenue laws, which are in charge of the solicitor of internal revenue. Though nominally attached to the treasury department, he is in reality an officer of the Department of Justice, and may be required by the Attorney-General to give his opinion in writing on any question of law submitted by any department for the opinion of the latter, except questions involving a construction of the Constitution of the United States, and to perform any other duty required of the Department of Justice or any officer thereof.

It will thus be seen that the details involved in the transaction of the immense and varied business of the fiscal department of the United States government are

wisely and systematically distributed among a series of responsible officers. The clerical and other forces employed in the various offices and bureaus number 15,697, of whom 2852 are in bureaus at Washington, 4450 in the customs service, 3303 in the internal revenue service, 948 in the mints and assay offices, 225 in the several sub-treasuries, and 3919 in the life-saving, marine hospital, steamboat inspection, and revenue marine bureaus, and in the various public buildings and other branches of the department located throughout the country.

The general system of accounting in force in the department—which was conceived and put in operation by Alexander Hamilton, its first secretary—has proven so admirably adapted to the purposes for which it was intended that but few modifications have since been made in its practical application.

The following statements exhibit the principal operations of the department during the fiscal year ending June 30, 1888, and the condition of the treasury at the close of the year:

Receipts and Expenditures.—The revenues of the government are mainly derived from duties on imports, and internal taxes upon distilled spirits, fermented liquors, tobacco, and banking. The expenditures are mainly on account of the war and navy departments, pensions, interest on the public debt, and the civil service. The revenues from all sources for the fiscal year 1888 aggregated \$379,266,074.76, of which \$219,091,173.63 were from duties on imports, \$ 24,296,871.98 from internal taxes, \$11,202,017.23 from sales of public lands, and \$24,676,011.92 from miscellaneous sources. The expenditures for the same period were \$267,924,801.13, as follows: civil and miscellaneous, \$72,952,260.80; war department, \$38,522,436.11; navy department, \$16,926,437.65; Indian service, \$6,249,307.87; pensions, \$80,288,508.77; premium on bonds purchased, \$8,270,842.46; and interest on the debt, \$44,715,007.47, leaving a surplus of \$111,341,273.63, of which \$43,732,550.00 was applied to the redemption of bonds for the sinking-fund, and \$31,081,013.05 to ordinary redemption of the debt. As compared with the previous fiscal year, there was an increase in the revenues of \$11,041,749.38 in the following items: duties on imports, \$1,804,280.50; internal taxes, \$5,473,480.76; sales of public lands, \$1,947,730.81; and from miscellaneous sources, \$1,816,257.31. There was a decrease of \$3,178,952.28 in the following: tax on circulation of national banks, \$637,284.33; sales of Indian lands, \$598,941.38; repayment of interest and sinking-fund, Pacific railroads, \$427,200.62, and from sales of old public buildings and miscellaneous sources, \$1,515,525.95, making a net increase of revenue of \$7,862,797.10. The expenditures were practically the same in the aggregate as for the fiscal year 1887.

The National Banks.—The following shows the condition of the national banks on June 30, 1888, as represented by reports from 3120 banks then in operation.

<i>Resources.</i>	
Loans and discounts.....	\$1,619,999,200.68
Overdrafts.....	8,125,364.15
U. S. bonds to secure circulation.....	177,543,900.00
U. S. bonds to secure deposits.....	55,788,000.00
U. S. bonds on hand.....	7,830,150.00
Other stocks, bonds, and mortgages.....	96,265,812.31
Due from approved reserve agents.....	158,133,598.31
Due from other national banks.....	101,689,774.90
Due from State banks and bankers.....	22,714,258.27
Real estate, furniture, and fixtures.....	61,101,833.19
Current expenses and taxes paid.....	5,685,313.21
Premiums paid.....	18,903,434.54
Checks and other cash items.....	16,855,801.15
Exchanges for clearing-house.....	74,229,763.69
Bills of other national banks.....	21,343,405.00
Fractional currency.....	632,602.42
Trade dollars.....	371.76
Gold coin.....	74,825,782.84
Gold treasury certificates.....	68,761,930.00

<i>Resources.</i>	
Gold clearing-house certificates.....\$	20,884,000.00
Silver coin, dollars.....	6,906,432.00
Silver coin, fractional.....	2,819,277.92
Silver treasury certificates.....	7,094,854.00
Legal-tender notes.....	81,995,643.00
U. S. certificates of deposit for legal-tender notes.....	12,315,000.00
Five-per-cent. redemption fund with U. S. Treasurer.....	7,765,837.16
Due from U. S. Treasurer other than redemption fund.....\$	1,236,675.66
Aggregate.....	\$2,731,448,016.16

<i>Liabilities.</i>	
Capital stock paid in..... \$	588,384,018.25
Surplus fund.....	183,106,435.70
Other undivided profits.....	70,296,173.67
National bank notes outstanding.....	155,313,353.50
State bank notes outstanding.....	82,372.50
Dividends unpaid.....	7,381,894.42
Individual deposits.....	1,292,342,471.28
U. S. deposits.....	54,679,643.93
Deposits of U. S. disbursing officers.....	3,690,652.65
Due to other national banks.....	248,248,440.03
Due to State banks and bankers.....	109,871,372.41
Notes and bills re-discounted.....	13,096,119.55
Bills payable.....	4,955,068.27
Aggregate.....	\$2,731,448,016.16

The Coinage.—The coinage executed at the mints of the United States during the fiscal year 1888 was :

Denomination.	Pieces.	Value.
<i>Gold :</i>		
Double-eagles.....	815,087	\$16,301,740.00
Eagles.....	899,826	8,998,260.00
Half-eagles.....	599,102	2,995,510.00
Three dollars.....	11,360	34,098.00
Quarter-eagles.....	6,273	15,682.50
Dollars.....	18,880	18,880.00
	2,350,534	28,364,170.50
<i>Silver :</i>		
Standard dollars.....	32,718,673	\$32,718,673.00
Half-dollars.....	5,673	2,836.50
Quarter-dollars.....	778,673	194,668.25
Dimes.....	12,199,175	1,219,917.50
	45,702,194	34,136,095.25
<i>Minor Coin :</i>		
Five cents.....	15,207,173	\$ 760,358.65
Three cents.....	45,573	1,367.19
One cent.....	45,725,073	457,250.73
	60,977,819	1,218,976.57
Total coinage.....	\$109,030,547	\$63,719,242.32

Imports and Exports.—The value of the merchandise imported into the United States during the fiscal year 1888 was \$723,879,813 as against \$692,319,768 during the previous fiscal year. The value of the exports of the products of agriculture, manufactures, mining, forestry, and the fisheries is thus shown :

Products of	Value.	Per cent.
Agriculture.....	\$500,785,314	73.24
Manufactures.....	130,312,408	19.00
Mining.....	18,067,051	2.45
Forestry.....	23,991,092	3.50
Fisheries.....	5,539,780	1.00
Miscellaneous.....	5,166,591	.75
Total.....	\$683,662,236	100.00

The value of the exports of agricultural products fell off from \$523,077,223 in 1887, to \$500,785,314 in 1888, while the exports of all other commodities increased from \$179,945,700 to \$183,076,922.

The Public Debt.—The following table shows the total amount of the national debt on June 30, 1888 :

Character of debt.	Amount.
Bonds at 4 1/2 per cent.....	\$229,207,050.00
Bonds at 4 per cent.....	714,177,400.00

Character of debt.	Amount.
Refunding certificates at 4 per cent..... \$	138,051.00
Navy pension fund at 3 per cent.....	14,000,000.00
Interest accrued on the above.....	9,671,459.96
Debt on which interest has ceased.....	2,496,095.26
Interest on matured debt.....	168,267.86
Bonds issued to Pacific Railroads.....	64,623,512.00
Interest accrued thereon.....	1,952,745.32
Demand and U. S. notes.....	346,737,823.50
Certificates of deposit.....	14,415,000.00
Gold certificates.....	119,887,370.00
Silver certificates.....	200,387,376.00
Fractional currency.....	6,922,643.82
Total.....	\$1,717,784,793.72

The net debt, after deducting the cash in the treasury, was \$1,165,584,656.64, as compared with \$1,279,428,737.02 at the close of the previous fiscal year.

The State of the Treasury.—The following is a statement of the condition of the public treasury on June 30, 1888 :

Liabilities.	Amount.
Gold certificates outstanding.....	\$119,887,370.00
Silver certificates outstanding.....	200,387,376.00
Currency certificates outstanding.....	14,415,000.00
Reserve for redemption of U. S. notes.....	100,000,000.00
Funds for retirement of bank circulation.....	91,952,843.65
Funds for redemption of national bank notes.....	6,976,727.62
Disbursing officers' balances.....	23,108,989.47
Transfer checks and drafts.....	3,007,955.85
Post-office department account.....	6,022,846.10
Matured debt and interest.....	14,289,926.37
Miscellaneous items.....	4,600,208.23
Balance.....	129,384,241.48
Total.....	\$714,033,484.77

Assets.	Amount.
Gold coin.....	\$203,636,984.04
Gold bullion.....	110,116,632.85
Standard silver dollars.....	243,879,487.00
Silver bullion.....	4,142,731.54
Trade-dollar bullion.....	6,477,022.82
United States notes.....	52,398,204.07
Deposits in national banks.....	59,979,039.63
National bank notes for redemption.....	6,770,380.08
Fractional and minor coin.....	26,163,776.77
Miscellaneous items.....	469,225.97
Total.....	\$714,033,484.77

(W. F. M.)

TREATY. While the government of the United States adheres to the general doctrines See Vol. XXIII. as to the nature and effect of treaties p. 530 (p. 564 Am. Rep.). prevailing among the states of Europe, it has introduced changes in the method of forming such treaties that were demanded by the nature of its political institutions. The international intercourse of the European states has been largely affected by the consideration that dynastic interests were intimately interwoven with national interests, giving to that intercourse a personal as well as national character. Having in our system eliminated this personal element it was possible that treaties should be made under the supervision of some representative body sustaining close relations to the people of the United States, and yet of such stability as to insure a high degree of uniformity and persistence in the policy of our diplomatic relations with other powers. The selection of the Senate to revise the executive action in the making of treaties, leaving the power of negotiation in the hands of the President, secured at once the advantages to be derived from executive unity with those resulting from a divided responsibility in which the representatives of the people participate.

As the Senate in the performance of this function sits as an executive body and not in its character as a branch of the legislative body, the treaty-making power as it exists with us is to be regarded as strictly

executive in its nature, and therefore of the same quality as that exercised under the governments of Europe. It follows that our engagements with foreign powers are not under the legislative control of Congress but are the products of executive action alone. It is true that as to the domestic effect of a treaty it may be entirely controlled by Congress, so that obligations imposed upon the citizens and officers of this country by treaties may be remitted by Congress, and rights secured thereby may before such treaties have passed into actual execution be denied by Congress, but where the national faith has been pledged to a foreign power by a treaty duly made and ratified by the proper executive authority Congress cannot undo the obligation thus imposed without the consent of the power with which the engagement has been made. In this respect a treaty made by the national executive stands on the same footing with one made by an absolute sovereign, and that it should have that character is essential to the maintenance of international intercourse.

The Constitution of the United States gives to the domestic operation of treaties made under its authority the quality of law, declaring that they should constitute part of the supreme law of the land, but does not place the disposition made by treaties beyond the power of Congress as it regards their domestic operation. The existence of an obligation implies the possibility that the obliged party may not conform to its requirements, in which case compensations or punitive consequences appropriately follow, and such power of conforming to or declining what is demanded under an obligation must in the nature of things reside somewhere, and under our system it resides in Congress.

If there is any instance in which Congress can control the relations of the nation with foreign powers it would be found in the instance of treaties of pacification where war has been formally declared by its authority, but the current of opinion seems to flow in the direction of allowing to the treaty-making power authority to change the status of war, although created by a legislative act, into that of peace. Where, however, the conditions of peace called for the payment of money, as in the instance of the war with Mexico, under which a large portion of the present territory of the United States was acquired, an appeal to the legislature is a practical if not a legal necessity. No case has arisen to test the ability of the treaty-making power to alienate the territory of the United States except as a mere incident of the ascertainment or perfecting of uncertain or disputed boundaries. It is a singular fact that, while the legislative power of the nation is placed under constitutional limitation to keep it in proper channels, no such care has been exhibited in the case of the diplomatic powers of the government, and the existence of limitations of that which properly falls within the nature of that power must depend on inferences from rather than direct expressions of the Constitution.

The earliest stage of our national diplomacy was occupied with the establishment of relations of amity and commercial reciprocity with the various powers of Europe. A broad and liberal policy of international relationship had been mapped out while the government was still under the Articles of Confederation that was continued under the Constitution. The political policy of the diplomacy of the country was placed in a condition in which it has remained until the present day. The geographical position of the United States rendered unnecessary the diplomatic complications that are rendered necessary in Europe by the number and proximity of the competing powers, and the avoidance of foreign alliances for political purposes was early accepted as a principle of our diplomacy. Nor have the conditions tending to allow simplicity to our relations with other powers looking to political objects materially changed. Neither the security nor the influence of the United States depend upon alliances,

but have been found to be best secured by an impartial treatment of all other powers.

The development of an impartial system of international commercial intercourse engaged the attention of the early diplomats of the country and especially interested Pres. Jefferson. It was sought to place the interests of navigation and commerce upon the security afforded by a generous scheme of reciprocity broad enough to include all the powers with which the United States desired commercial relations, conferring special favors on none and withholding from none that which impartiality would confer upon them. To accomplish this it was necessary that the practice of European diplomacy by which commercial favors were balanced against political favors should be avoided and that the interests of commerce should be entirely separated from those of a political nature. The consequence of this policy was that rights of commerce and navigation were in the United States fixed by general laws equally applicable to all nations, rather than by special treaty engagements with the several powers. For many years duties upon foreign importations of merchandise and dues to which the right of navigation was subjected were established by general laws allowing no exclusion of any power that was willing to reciprocate like advantages.

This impartial policy was to a limited degree infringed by an event that marked the second stage of the diplomatic policy of the United States. The immigration into Kentucky brought an enterprising population into contact with the problem of the free navigation of the Mississippi River, the western bank of which was within the jurisdiction of France. The purchase of the right of France to the territory west of the Mississippi and which was known as Louisiana was pressed upon Jefferson upon his accession to the Presidency. He hesitated to take a step that seemed inconsistent with the views that he entertained as to the limited powers of Congress. To acquire that territory would require that Congress should expend the public money for that purpose, and such an object was not found among the enumerated powers of Congress and could by no means be regarded as a necessity of the execution of such enumerated powers. Jefferson's hesitation was overcome by the pressure of political interests, and the purchase was consummated through a treaty made with Napoleon, then First Consul of France. By this treaty certain commercial advantages within the ceded territory were allowed to France and Spain for a limited period of time, from which other nations were to be excluded, and thus Pres. Jefferson in addition to inflicting a wound upon the doctrine of States rights contradicted to a limited extent the impartial commercial system to which he had devoted his thought and effort.

The diplomacy of the United States had now entered upon the career of territorial aggrandizement which was not likely to be ended while any portion of the continent of North America lay outside of its jurisdiction. This precedent, set in 1803, was followed in 1819 by the purchase of the Floridas from Spain, and at the conclusion of the war with Mexico by a treaty purchase that carried the jurisdiction of the United States to the Pacific Ocean. In 1867 the purchase of Alaska from Russia marked the last step taken in the direction of the diplomatic policy of the extension of the territory of the United States.

The acquisition of territory by these various treaties did not encroach upon the principle of keeping apart in international intercourse political and commercial interests, so that the acquisition of advantages in reference to one of these classes should not entail disadvantages upon the other, except in the case of the Louisiana purchase, where certain exclusive privileges were granted that were not to be common to all other powers. It is true that that exclusive advantage was given as part of the price of the territory acquired, and thus something was taken from the interests of com-

merce to enhance the political interests of the country in the extension of its territories, and that as the direct interest in commerce is individual, the public interest in it being indirect merely, it was something taken from the individual advantages incident to an unrestricted commerce, to be conferred upon the public or political interest of the nation. But notwithstanding that this incident was an encroachment upon the principle that the interests of commerce should not become the price of political advantages, the limited character of the exclusive privilege conferred can hardly entitle it to be regarded as a serious departure from the antecedent diplomatic policy.

An emphatic step of departure from that policy was taken by the treaty with the Hawaiian Islands in 1875. That treaty gave a discrimination as to customs duties on merchandise interchanged between the two countries that gave to Hawaii privileges not enjoyed by other nations with which the United States had treaties and commercial intercourse, notwithstanding many of those treaties excluded imposts that were not equally imposed upon all other countries. Although the Hawaiian treaty gave similar advantages to the United States as to certain classes of merchandise introduced into the islands, yet the history of the diplomacy and concurrent legislation shows distinctly that political rather than commercial advantages prompted the action of the United States in making that treaty, naval advantages and the desire to exclude European influence from the control of the islands forming an important part of the motive to the treaty. Whether the reactionary step taken in the instance of the Hawaiian treaty is to be the first of a series of steps to lead back to the old system of trading in the interests of commerce for political advantages, and thus to defeat the systematic organization of international commercial intercourse, cannot be determined at the present time.

Modern diplomacy has assumed important functions in the development of international law that marks an advance from the condition of early diplomatic action. The international system has been formed by a slow process from the habitudes of commercial interchange and national intercourse, in this respect having the same nature as the common or unwritten law which is the product of the judicial recognition of persistent social habit. Treaties have in the past had some influence upon this process, but treaty relations between particular states have only indirect effect upon the general habitudes of international intercourse, although particular customs in process of time often become general.

It is only of late years that the spirit of diplomacy has broadened to a policy of giving systematic development to the international law. A striking effort of this character appears in the instance of the effort that was made by the United States to secure a clear and liberal definition of the relations of belligerent and neutral states by its introduction into the treaty made with Great Britain in 1871 that had a particular relation to the settlement of the Alabama claims (*q. v.*). Such efforts on the part of the United States entitle this nation to be regarded as the patron of systematic diplomacy, and are the outgrowth of the principle of impartial international relationship, that has already been referred to as in the early diplomacy of this country applied to the interests of navigation and commerce. While diplomacy was recognized as the art of aggrandizing the condition of individual states, its functions were necessarily limited, but with the development of an international spirit it has entered a more useful and interesting sphere.

The suppression of the slave-trade is another interest of international law that has received attention from the diplomacy of the United States, and as connected with this subject effort has been addressed to a more accurate definition of the right of search at sea, a subject that once involved this country in hostilities with Great Britain. (See **SEARCH, RIGHT OF.**) The

United States fully sympathized with Great Britain in her efforts to suppress the African slave-trade, but at the same time desired to guard their maritime interests against abuses of the right of visitation and search. By the treaty, negotiated by Secretary Seward with Great Britain in 1862, the principle applied internationally to the case of piracy was extended under careful limitations to the African slave-trade.

A still more important subject as affecting the administration of justice is that of the extradition of persons charged with crime from countries to which they have fled to that country in which the crime was alleged to have been committed. Apart from treaty stipulations there was no mode by which the government or country in which crime had been committed could secure persons charged with such crimes for the purposes of justice while within the territory of another power. The United States has taken a prominent place in the effort to supply what is demanded by this important international interest. In 1843 a provision of that character was negotiated with France, and in 1846 a similar provision was concluded with Great Britain. In the treaty with the latter the crimes for which extradition could be claimed are specifically enumerated, and are murder, assault with intent to commit murder, piracy, and the utterance of forged paper. A specific enumeration of the offences for which extradition might be claimed was important principally for the purpose of excluding political crimes from the class. Crimes against governmental stability and order are intimately connected with popular efforts to reform existing institutions, and as the United States recognized the right of the people of a community to adjust its government to their needs or ideas, it was unwilling to lend its assistance to sustain oppressive governments or to prevent the people from securing good ones. The diplomacy of the United States has separated the idea of an asylum for those under political oppression from that of defeating the ends of justice by harboring criminals from other countries, and has shaped its course to subserve the ends of justice without denying an asylum to the oppressed of other nations.

The United States have contributed to modern diplomacy another important feature by efforts to improve the conditions of international judicature. As it is no part of the policy of the United States to use the right of conquest for the enlargement of its territories or the enhancement of its military or political influence, no motive exists to prevent the establishment of rational methods of determining international controversies. The treaty of 1783 with Great Britain left undefined the North-eastern part of the boundaries between the possessions of the two countries. In 1794 a commission was provided for by treaty to complete the location of that boundary-line, but this commission failed to reach a satisfactory result. In 1814 it was agreed between the two powers that the question of difference should be referred to a friendly sovereign for final settlement. The King of Netherlands was selected for that purpose, who rendered a decision that was not acceptable to the United States, and, indeed, that was not in accordance with the views of Great Britain. The leading objection to the decision of the King of Netherlands was, that instead of adjudicating the exact question submitted to him, he had propounded a compromise line as best conforming to his views of the interests of the respective countries. The United States had sought a judicial solution of the points of difference, and was dissatisfied with an arbitrary conclusion that expressed nothing beyond the personal opinion of the arbitrator. Great Britain was urged to constitute a commission that should proceed according to recognized methods of adjudication. Great Britain declined these tenders, and for many years the question remained unsettled. By the treaty of 1842 with Great Britain, known as the Ashburton treaty, the question was disposed of by diplomatic methods.

The question of the North-western boundary of the United States still remaining unsettled, it was referred by the treaty of 1871 with Great Britain to the Emperor of Germany for decision, and was afterwards decided by him and carried into effect. The treaty of 1871 also made provision for the settlement of the claims against Great Britain on account of the losses sustained through depredations committed by cruisers of the Confederate government built and fitted out in English ports. The United States desired that the claims on account of such depredations should be decided on judicial principles and Great Britain yielded to that desire. A tribunal was constituted for that purpose by the treaty and methods of procedure stipulated in conformity with recognized methods of judicial procedure. The result was a decision favorable to the United States, while the procedure is universally recognized as in a judicial spirit. (See ALABAMA CLAIMS.)

The instances referred to illustrate fully the tendency of American diplomacy to formulate methods of settling international controversies that are conformable to the principles applied in domestic acts of justice. Should a time occur when the leading nations are willing to forego the opportunities of aggrandizement afforded by war, the effort of the diplomacy of the United States so well begun will be attended with the large success to which its principles entitle it.

As the government of the United States is the sole medium of communication between the people of the various States and foreign countries, the duty devolves upon it of protection to all the people of the various States and Territories travelling, residing, or trading in foreign countries, and elaborate provisions are made in treaties with the various powers to meet the contingencies likely to occur in the course of such occupation abroad.

From the first settlement of the American continent the relations of the European settlers to the Indian tribes occupying the country were adjusted by treaties, and at the formation of the Constitution this intercourse with the Indian tribes was committed to the treaty-making power of the government. Since 1873 this method of dealing with the Indians has been discontinued, and acts of Congress have taken the place of treaties as means of adjusting such relations. The history of the exercise of the treaty-making power in its application to the Indian tribes does not exhibit the same tendency to give expression to the higher principles that should actuate societies of men that appears in the other branch relating to international intercourse. As the least favorable aspect of the policy of a country is that which concerns the means for enlarging its territories, the fact just stated may be accounted for. By this important power a continent has been purchased, and an annual disbursement to supply the simple wants of a remnant of that people represents its price. (See INDIANS.) (A. J. W.)

TREITSCHKE, HEINRICH GOTTHARD VON, German historian, was born at Dresden, Sept. 15, 1834. He studied at the Universities of Dresden and Leipsic, and at the School of Agriculture at Lutzschena. In 1863 he was made professor in the University of Freiburg, but on the outbreak of the war between Prussia and Austria in 1866 removed to Berlin, where he was made editor of the government annuals, in which he had assisted since 1858. He was soon afterwards called to Heidelberg University, and thence to Berlin in 1874. He had been already elected to the German Parliament, in which he belonged to the National Liberal party. Both in speeches and in writing he gave effective aid to Bismarck's movements for German unity and a centralized government. In early years he published two volumes of *Patriotic Poems* (1856), but he afterwards confined his literary labor to historical and political affairs. In his *Historische und Politische Aufsätze* (3 vols.), he discusses historically federal government, royalty, liberty, and kindred subjects. In

his *Der Socialismus und Seine Gönner* (1875) he attacks the professorial socialism then spreading in Germany. His *Zehn Jahre Deutscher Kämpfe* (1875) treats of the movements through which the kingdom of Prussia became the German empire. This work was but preliminary to his more important and comprehensive *Deutsche Geschichte im 19 Jahrhundert* (5 vols., 1879-86). Von Treitschke exhibits the industry and sagacity of Ranke, but he has confined his labors to a much narrower field, his own country and century.

TRENTON, the capital of New Jersey, county-seat of Mercer co., is on the Delaware River, at the head of tidewater and steamboat navigation. By the New York division of the Pennsylvania Railroad it is 56 miles from New York and 33 from Philadelphia. The Bound Brook branch of the Philadelphia and Reading Railroad also connects it with those cities, and several other railroads pass through or terminate in the city. There is also daily steamboat communication with Philadelphia. Two fine bridges here cross the Delaware. Assanpink Creek divides the city into two parts. Trenton stands chiefly on high ground, and has wide, shady, well-drained streets. Handsome residences occupy picturesque sites in the suburbs. The public buildings comprise a fine State-house, U. S. government buildings, county court-house, city-hall, State Lunatic Asylum, State Arsenal, penitentiary, State Reform School, and State Normal School. There are also a high-school and several public and private schools, a public library and other libraries, an opera-house and several halls, 2 national banks, 2 State banks, and a savings bank, several hospitals and other buildings for benevolent and charitable institutions. Four daily and 6 weekly newspapers are published here. Trenton is largely engaged in manufactures, and its potteries have a deservedly high reputation. There are also extensive rolling-mills, zinc- and iron-works, and works producing saws, tools, chains, India-rubber goods, fire-bricks, and terra-cotta. The water-power of the Delaware is largely utilized for manufacturing purposes. The city has a good fire department, ample supply of water, and has gas- and electric-lights. Its population in 1880 was 29,910.

TRENTON, BATTLE OF. When Gen. Washington, in the autumn of 1776, was compelled to retreat from the vicinity of New York city, the affairs of the American patriots had sunk to a low ebb. He sought refuge in Pennsylvania, guarded by the Delaware River. The British troops, which had been slow in pursuing him, were expecting soon to cross that river and capture Philadelphia. The term of most of the American soldiers was to expire with the year. Under these circumstances Washington decided to strike a counter-blow at the British in their winter quarters in New Jersey. His full plan included a crossing of the Delaware above and below Trenton, at Bristol, and at Philadelphia. The time selected was the night after Christmas, when the enemy would probably be demoralized. The only effective crossing was made at McConkey's Ferry, 9 miles above Trenton, where Washington commanded the left wing in person. The fierce north-east snow-storm hindered even his movements and prevented the others. After he had crossed, his men, numbering 2400 all told, were divided into two divisions, Sullivan taking the river road, while Washington, with Greene, reached Trenton by the Pennington road. At Trenton Hessian mercenaries, numbering about 1550 men, under Col. Rahl, occupied barracks. The two American divisions came upon them about 8 A. M., and placed artillery in position to command the streets and roads, and detachments sent out to cut off the retreat to Princeton and to Bordentown. The Hessians' guns were quickly captured, and, though Col. Rahl exerted himself to form his troops in position, they were unable to do so. He was killed while urging an assault, and his followers surrendered. Their loss was 40 killed and wounded.

and nearly 1000 captured. Six bronze guns, over 1000 stands of arms, and various stores were taken. The American loss was 2 killed and 3 wounded, and 2 were frozen to death in recrossing the river. Washington with his army returned to his head-quarters on the same night. The Hessians were sent to Philadelphia, and marched through its streets, that the dread of them might be dispelled.

TRINITY COLLEGE. The General Assembly of the State of Connecticut in May, 1823, granted a charter for the establishment of a second college in the State, under the name of Washington College; and in 1815, in compliance with the wishes of the alumni and the corporation, the name of the institution was changed to Trinity College. The plan of the college originated with the Episcopalians of Connecticut, who had established, in 1795, a seminary of liberal learning, but who had in vain sought to gain for it the power of conferring degrees. At length, in 1818, a remarkable combination of circumstances—social, religious, and political—led to a revolution in the State, the immediate results of which were the overthrow of the "Stanley Order" of Congregationalism, and the adoption of a State constitution. In the following year the long-existing vacancy in the bishopric of Connecticut was filled by the election of the Rev. Dr. Thomas Church Brownell, who had been for ten years tutor and professor in Union College, a man of learning, prudence, and practical wisdom. Under his guidance advantage was taken of the opportunity to present a petition for a new college; and after a struggle, in the literature of which one finds political and financial questions curiously mingled with those relating to religion and education, the act of incorporation was granted. The incorporators included prominent representatives of the religious bodies who had united in opposition to the old establishment; and the charter contained a clause providing that no religious test should ever be required of officers or students.

In consequence of the generous gifts of the citizens of Hartford the trustees voted to locate the college in that city, and a beautiful site was secured for the buildings. These were of brownstone, in the Ionic order of architecture, of which two were erected at once, and a third in 1815. A faculty of learned men was gathered, and the institution began its work in 1824. Bishop Brownell was chosen president; after faithful service, he retired in 1831, and was succeeded by the Rev. Dr. N. S. Wheaton, a steadfast and liberal friend of the college, who did much to enlarge its usefulness. His successors were: in 1837, the Rev. Dr. Silas Totten, professor of mathematics; in 1848, the Rev. Dr. John Williams, who left academic duties here to discharge with no less remarkable ability those of the assistant bishopric, and afterwards the bishopric, of Connecticut; in 1851, the Rev. Dr. D. R. Goodwin, a profound metaphysician; in 1860, Dr. Samuel Eliot, a man of wide and graceful scholarship; in 1864, the Rev. Dr. J. B. Kerfoot, an experienced educator, who was soon called to the bishopric of Pittsburgh; and in 1867, the Rev. Dr. Abner Jackson, formerly professor here, and then president of Hobart College, who died in April, 1871. In the course of fifty years the college had experienced many changes, though it had always held firmly to its ideal as a place of liberal education under the guidance of Christian principles. Its endowments had been increased by numerous gifts, and the course of instruction, which had from the first been practically the same as that of the other colleges of New England, with provisions for special students, had been modified from time to time to meet the demands made upon it. A graduate department had been organized for the study of theology, but it had soon (in 1851) become a separate institution, and, under the name of the Berkeley Divinity School, had been located at Middletown. In 1871 the number of undergraduates for the first time reached a hundred.

Near the end of Dr. Jackson's presidency the trus-

tees accepted an offer from the city of Hartford to purchase the campus as a site for the State capitol, and elaborate plans were prepared for buildings to be erected on a new campus of eighty acres situated on a bluff in the southern part of the city. The work was delayed by Pres. Jackson's death; but his successor, the Rev. Dr. Thomas R. Pynchon, prosecuted it with great energy. In 1878 two blocks of buildings, each 300 feet long, were finished, and the college was removed to its new home. Four years later these buildings were connected by a tower 70 feet square, thus completing the west side of the great quadrangle of the architect's plans. In 1883 the Rev. Dr. George Williamson Smith was chosen president. In the following year considerable changes were made in the course of instruction, in order to introduce elective studies into the work of the latter half of the course and to provide for four distinct schemes of study; one leading to a degree in arts and two to a degree in science. An observatory and a president's house were soon built, and the last two years have seen the erection of a gymnasium and alumni hall and of the Jarvis Hall of Science, standing outside of the space reserved for the quadrangles. The style of architecture of these quadrangles is that known as French secular Gothic, and there can be included in them great piles of buildings to provide amply for the present and prospective needs of the college. The library is furnished with 30,000 volumes, and is rapidly increasing, and the museum is well supplied with material for study.

The number of alumni has been about 900, many of whom have attained eminence in various professions and walks of life. Among the liberal benefactors of past years special mention should be made of Mr. Chester Adams, of Hartford, Col. and Mrs. C. H. Northam, of Hartford (whose name has been given to the central tower), Mr. Junius S. Morgan, of London, Mr. George A. Jarvis, of Brooklyn (the donor of the hall of science), and Mr. S. M. Buckingham, of Poughkeepsie. Of those who have served in the faculty two are specially worthy of honor on account of their long connection with the college: Prof. Duncan L. Stewart (1833-1880), and Prof. John Brocklesby (since 1842).

(s. ff.)

TRIST, NICHOLAS PENDLETON (1800-1874), politician, was born in Virginia, and educated at West Point, where he for a time taught French. He removed to Washington, and was a warm political friend of Pres. Jackson. He had married a granddaughter of Pres. Jefferson and carefully preserved the traditions and principles of that statesman. In 1845 he was made chief clerk of the State Department, and during the Mexican war he was sent to Mexico as the direct representative of Pres. Polk, and endeavored to control Gen. Scott's movements, so far as they had political bearing. Trist negotiated the treaty of Guadalupe-Hidalgo in January, 1848. He was afterwards U. S. consul at Havana, and finally postmaster of Alexandria, Va. He died there Feb. 11, 1874.

TRISTRAM, HENRY BAKER, English clergyman and naturalist, was born at Eglingham, England, May 11, 1822. He was educated at Durham and at Lincoln College, Oxford, graduating in 1844. After travelling for a year on the continent he was ordained and became curate of Morehard Bishop. In 1847 he went to Bermuda as chaplain and secretary to Sir Charles Elliott. After visiting the United States in 1851 he returned to England and became rector of Castle Eden, where he established a training-school for female teachers. In 1855 he was compelled by ill health to seek a warmer climate and went to Algiers. His winter excursions to unexplored localities furnished material for his first book, *The Great Sahara* (1856). In 1860 he was made vicar of Greatham and master of Greatham Hospital, which he enlarged and improved. In 1870 he was made honorary canon of Durham, in 1874 canon, and in 1880 dean. He has held also other ecclesiastical positions, and in 1879 was

offered the bishopric of Jerusalem, but declined it. He has made five expeditions to Palestine and Syria and his explorations have been recorded in several books, which have attained wide circulation. Among them are *The Land of Israel* (1865); *Natural History of the Bible* (1867); *Daughters of Syria* (1869); *Bible Places* (1872); *The Land of Moab* (1873); *Fauna and Flora of Palestine* (1884).

TROLLOPE, THOMAS ADOLPHUS, novelist, historical and descriptive writer, was born in London, England, April 29, 1810. He is a son of Mrs. Frances Trollope, whose strictures on American manners are not yet forgotten, and brother of Anthony Trollope, for whom see the *ENCYCLOPEDIA BRITANNICA*. After completing his education at Oxford University, in 1840, he produced two volumes on Brittany, followed next year by two on Western France. He then took up his residence in Florence, and has been a most prolific writer on Italy and Italian subjects. His *Impressions of a Wanderer in Italy* appeared in 1850, followed next year by *Girlhood of Catherine de Medici*, *A Decade of Italian Women*, and *Tuscany* in 1849. In 1860 he published his *Filippo Strozzi* and *Paul the Pope and Paul the Friar*. While he did not equal his brother in rapidity of production nor in popularity, yet each succeeding year, down till 1870, saw one or more new works from his pen. His novels range freely from Italian to English subjects. Among them are *La Beata*, *Marietta*, *Giulio Malatesta*, *Beppo the Conscript*, *Luudisfaru Chase*, *Gemma*, *Artingall Castle*, *Dream Numbers*, *Lemora Carolini*, *The Garstangs of Garstang Grange*, *Durton Abbey*. His most important historical work is the *History of the Commonwealth of Florence, from the Earliest Independence of the Commune to the Fall of the Republic in 1531* (4 vols., 1865). He wrote also a *Life of Pope Pius IX.* (2 vols., 1877), and in 1888 published a volume of reminiscences under the title *What I Remember*.

TROOST, GERARD (1776-1850), scientist, was born at Bois le Duc, Holland, March 15, 1776. He graduated in medicine at the University of Leyden, and practised at Amsterdam and the Hague. He entered the army of Holland as a private, but soon was commissioned in the medical department. Louis Bonaparte, while king of Holland, showed Troost special favor, and in 1809 sent him to Java on a scientific exploring expedition. He was, however, captured on the voyage and carried to France, and thence was permitted to sail for America. King Louis having abdicated, Troost settled in Philadelphia and established a manufactory of alum in Maryland. He was first president of the Philadelphia Academy of Natural Sciences 1812-17, and first professor of chemistry in the college of pharmacy 1821-22. In 1821 he joined Owen's socialist community at New Harmony, Ind., but on its failure in 1827 went to Nashville, Tenn. Here he was soon made professor of chemistry and geology in the university and in 1831 geologist of the State of Tennessee. In 1849 this position was abolished, and on Aug. 14, 1850, Dr. Troost died at Nashville.

TROUT, the name given to the smaller, river-dwelling species of the salmon genus, and also to several larger members of the genus inhabiting the great lakes and the ocean. The number of species of North American salmon and trout was enumerated at 43 in 1873, but has been reduced to 18 in the amended list of Gill and Jordan. The old genus *Salmo* has been retained for only a portion of the species, the red-spotted trout, the lake trout, and some other species being assigned to genus *Salvelinus*. The speckled trout, *Salv. fontinalis*, the brook trout of the Eastern United States, is found between 32° 30' and 55° N. lat. in the lakes and streams of the Atlantic water-shed and near the sources of a few rivers of the Mississippi system and some southern affluents of Hudson Bay. The members of this genus are known in England as charrs, in distinction from the black-

spotted trout. In America they inhabit only clear and cold mountain streams and lakes, and seldom venture to the sea, though probably restrained from doing so only by the warmth of the lower waters of the rivers. The brook trout is one of the most beautiful of fishes, though probably the least graceful of the charrs. It has a somewhat heavy head and large mouth. The back is more or less mottled and barred with olive hues and colored with large red spots, the dorsal and caudal fins being also barred and mottled. In extreme southern range the brook trout reaches Northern Georgia, where, however, it is only a fingerling, while along the Canada border it frequently reaches a weight of 10 lbs. Ordinarily it seldom weighs over 2½ lbs. It is the favorite game-fish of American waters, being the most shy, most cunning, and mettlesome of all our fish, while in beauty and delicacy of flesh it is unsurpassed. It is found from the tiniest brooks to the largest rivers, is a bold biter, but by its wariness calls out the greatest skill of anglers in its capture. In the spring it delights in rapid-flowing waters, but in hot midsummer retires to deep and shady pools. The streams, however, are being rapidly depleted of this fine game-fish, and, in the words of an experienced angler, "This is the last generation of trout-fishers. The children will not be able to find any." Yet the hardiness of the brook trout renders it well adapted to artificial culture, and it may be preserved in this manner. It has been successfully planted in Europe.

Of other American charrs may be named *S. oquassa*, an exquisite little fish of the Rangeley chain of lakes in Maine, the allied *S. arcturus*, from extreme Arctic America, and the Greenland charr, *S. stagnalis*. The great lake trout, *S. namaycush*, has been placed in the same genus, though with some peculiarities of character. It is found in all the larger lakes from New England to Alaska. It varies from 15 to 80 lbs. weight, sometimes larger, and is of high rank as a food-fish. In color it is grayish, with paler spots. Compared with the other trout it is sluggish, heavy, and ravenous, its great size and strength alone giving it value as a game-fish. It keeps low, and seldom leaps out of the water like brook trout. It is caught principally in gill-nets, and in the winter through holes in the ice. It does not ascend rivers, but spawns in the shallower places near shore. Another fish of this group, *S. malma*, the Dolly Varden trout of the Sacramento, is a beautifully colored fish, nearly related to the brook trout. It is found in all the Pacific rivers, reaching 14 lbs. extreme weight, but averaging much less. It ranks high as a food-fish, and occurs abundantly from Puget Sound northward.

The black-spotted trout, *S. purpuratus*, a widely distributed fish of the streams of the Pacific region, is classed by Jordan in the sub-genus *Salar*, as it differs in some particulars from the typical *Salmo*. It is found only in the region west of the Mississippi, extending thence to the Pacific. This species, known also as the mountain trout, spotted trout, silver trout, etc., occurs in all the rivers west of the Rocky Mountains, varying in size from 2 inches to 2 or 3 feet in length. It descends to the ocean, where it is known as salmon trout, and attains a weight of 30 lbs.

The rainbow trout of the same region, *S. irideus*, known also as brook trout, golden trout, speckled trout, etc., is a small species, from 4 to 12 inches long, its extreme weight being 5 or 6 lbs. It is found in all the mountain streams and is a good table-fish, but lacks the gameness and activity of the eastern brook trout. It has been somewhat extensively introduced into the waters of the Eastern United States.

S. Gairdneri, the steel-head trout, is another very common western species, being found in every stream and lake from New Mexico to Washington Territory, and northward to Kamtschatka. It is more active and gamy than the rainbow trout, larger and harder, and likely to prove a more useful acquisition to eastern

waters. It averages about 15 lbs. weight. The Rio Grande trout, *S. spilargus*, inhabits the head-waters of the Rio Grande, Rio Colorado, and their tributaries. It is the finest food-fish of New Mexico and Western Colorado, and probably inhabits all streams of that region to the Sierra Nevada. It is larger than the rainbow trout.

Much has been done towards the artificial propagation of the more important species of trout during recent years, eggs having been taken in considerable numbers from the brook, the lake, the rainbow, and other species and the fry distributed in various streams. A large station was recently formed at Neosho, Missouri, for the propagation of trout and other fishes indigenous to that region, and several other stations are devoted to trout propagation. What the result will be is yet to be determined. (C. M.)

TROWBRIDGE, JOHN, physicist, was born in Boston in 1843. He graduated at Lawrence Scientific School in 1866, and remained there two years as teacher. In 1868 he was appointed assistant professor of physics in Massachusetts Institute of Technology. In 1870 he accepted the same position at Harvard College, where he received in 1873 the degree of Doctor of Science, and in 1879 he accepted the chair of experimental physics. At Harvard College he established the largest laboratory of its kind in America. Having observed that the time signals of the college observatory were transmitted through the earth over a great extent of territory, he suggested to Mr. Preece, of London, the possibility of telegraphing signals across large bodies of water without a wire. Mr. Preece established the fact by transmitting telegraphic signals from Southampton to the Isle of Wight. Prof. Trowbridge is associate editor of *The Journal of Science*, and his various scientific papers are to be found therein, and in the *Popular Science Monthly* and the *Atlantic Monthly*. He invented the cosine galvanometer, and is member of a number of scientific associations.

TROWBRIDGE, JOHN TOWNSEND, novelist, was born at Ogden, N. Y., Sept. 18, 1827. He was brought up on a farm, but early displayed literary proclivities. At the age of 19 he was a journalist in New York city and at 20 he went to Boston, where he wrote popular tales under the name of "Paul Creyton," and edited a weekly newspaper. His *Father's Bright Hopes* (1853) was the first of a long series of stories, specially adapted to boys' reading—pure, bright, and stimulating to exertion. *Neighbor Jackwood* (1855) and *The Old Battle Ground* (1859) are excellent examples. *Chief's Care* (1863) and *The Drummer Boy* are tales founded on incidents of the civil war. *The South* (1866) was a record of the author's observations in his travels after the war. Trowbridge had in the meantime obtained a higher fame by his vivid and pathetic poem, "The Vagabonds," first published in the *Atlantic Monthly* in 1863, and though he has written other poems he has never excelled this sketch. After being for some years a regular contributor to the *Atlantic Monthly* he became in 1870 the editor of *Our Young Folks*, a highly successful juvenile magazine, which was afterwards merged in *St. Nicholas*. Of his later novels may be mentioned *Coupon Bonds*, *Martin Merriale*, and *Neighbors' Wives*.

TROY, a city of New York, county-seat of Rensselaer co., is on the east bank of the Hudson River, at the head of steamboat navigation, 6 miles above Albany. It is in N. lat. 42° 41' and W. long. 73° 38'. It is on the New York Central, the Delaware and Hudson, and the Fitchburg Railroads. Street-railroads run to Lansingburg and the suburb called Albion. During the summer there is daily steamboat communication with New York. The city is chiefly on an alluvial plain, 3 miles long and over half a mile wide, but extends also over the hills to the east. Mount Ida on the south affords an extensive view of the surrounding country. River street follows the curve of

the Hudson, but other streets branching from its northern part run directly south. The court-house is an imposing marble edifice in the Doric style, and the Troy Savings Bank has a costly structure with a fine marble hall. There are 9 hotels, 9 national banks, 48 churches—some of which have fine edifices—two hospitals, orphan-asylums, a high-school, 15 public-schools, and several academies. The Rensselaer Polytechnic Institute has a national reputation. There are 2 daily and 4 weekly newspapers published here. The industrial works of Troy include cotton-, knitting-, and paper-mills, stove- and car-wheel-factories, iron- and steel-works, and bell-foundries. An important manufacture is that of shirts and collars, about 8000 girls being employed in this industry. Troy distributes its manufactured products more widely than any other city in the United States. The city has gas and electric light and water-works, for which there is an indebtedness of \$380,000, the rest of the city debt being over \$750,000. The yearly expenses exceed \$550,000. The total valuation of property is \$47,847,230. Troy was settled by the Dutch in 1659 and incorporated in 1816. Its population in 1880 was 56,747.

TRUMBULL, HENRY CLAY, Sunday-school worker and editor, was born at Stonington, Conn., June 8, 1830. He belongs to a family noted in the history of Connecticut, some of whose members are briefly sketched in the *ENCYCLOPEDIA BRITANNICA*. He was educated at Williston Seminary, East Hampton, Mass., and removed to Hartford, Conn., in 1851. Here he became State missionary for the American Sunday-School Union, and in 1861 was ordained to the ministry, that he might become chaplain of the Tenth Connecticut Volunteers. He was taken prisoner before Fort Wagner, S. C., in 1863. On returning from army service in 1865 he was appointed S. S. missionary secretary for New England, and in 1871 was made normal secretary. He removed to Philadelphia in 1875 to take charge of the *Sunday-School Times*, which he has since edited with great skill and efficiency. In 1881 he made a visit to Palestine, the chief result of which was his successful determination of the previously disputed locality of Kadesh-Barnea. Besides his interesting work *Kadesh-Barnea* (1884), he published *The Blood-Covenant* (1885), applying to the interpretation of Scripture the wide-spread usage of covenanting by shedding and mingling blood. Dr. Trumbull has also published many works on Sunday-schools, the chief being *Yale Lectures on the Sunday-school* (1888).

His brother, **JAMES HAMMOND TRUMBULL**, has become noted for his acquaintance with native American languages. He was born at Stonington, Dec. 20, 1821, and studied at Yale College, but ill health prevented his pursuing a professional career. He was corresponding secretary of the Connecticut Historical Society from 1849 to 1863, and in the meantime edited *Connecticut Colony Records* (3 vols., 1850-59). He was afterwards president of this society. His study of the American aboriginal languages commenced in 1858, and he was active in forming the American Philological Association in 1869. He was appointed State librarian in 1851; he was made assistant secretary of state in 1858; in 1861 he became secretary of state, and held that position until 1865. He has edited many documents of colonial times and has published *Origin of McFingal* (1868); *The True Blue Loaves* (1876), and has contributed to various periodicals on Indian names and historical subjects.

TRUST COMPANIES. Of the various classes of financial corporations connected with the monetary system of the country, none are of more importance than trust companies; which in a degree exercise the functions of both banks and savings banks. The charters of such corporations are obtained through the State Legislature, and as a rule contain the broadest of powers. In the State of New York, during the year 1887, provision was made for their organization under a general law, which however is not applicable to com-

panies previously chartered by special acts of the Legislature. The affairs of these corporations are managed by trustees or directors elected annually by their stockholders. Most charters prohibit trustees from borrowing the moneys or securities of the corporation, and require their capital, which varies from one hundred thousand to two millions of dollars, to be invested in bonds and mortgages or designated public securities. While such charters are not uniform, the main powers conferred are common to all. They are authorized to receive money on deposit and pay interest thereon and may receive securities and other personal property from individuals or corporations, and loan money on real estate and collateral or personal securities; or act as the fiscal agent of States, municipalities, or corporations, and in such capacity receive and disburse money, and transfer, register, and countersign certificates of stock, bonds, or other evidences of indebtedness; they also act as trustees under mortgages given by corporations, and accept and execute any other municipal or corporate trusts not inconsistent with law. They accept trusts from married women, and execute trusts for them in respect to their separate property and act as agent in the management thereof; they also take and accept by grant, assignment, devise, or bequest, and hold real or personal estate on trusts created in accordance with law. They are authorized to act, under the order or appointment of courts of record, as guardian, receiver, or trustee of the estates of minors, and as depositories of moneys paid into court for the benefit of minors; and may accept and execute such legal trusts, duties, and powers in respect to the holding, management, and disposition of estates and property, real or personal, and the rents and profits thereof, or the sale thereof, as may be granted or confided to them by courts, individuals, corporations, municipalities, or other authority. And they are accountable to parties in interest for the faithful discharge of all trusts, duties, or powers confided to and accepted by them.

The services rendered by trust companies are of great value to persons associating together as corporations for the purpose of starting new industries or enterprises, where the issue of stock or bonds becomes necessary, as they are authorized to act as transfer agent of stocks, and trustee under mortgages upon real and personal property or franchises of corporations, pledged as security for bonds issued. The payment of dividends on stocks and interest on bonds are also made through them. Married women having separate estates, and maidens possessed of fortunes, who are desirous of retaining control of their property after marriage, find the services of these corporations particularly desirable, owing to the strictly confidential character of all of their business transactions. Persons wishing to provide beyond contingencies for the support, maintenance, and education of minor children, or for the support of offspring mentally incompetent, or those addicted to dissolute habits that unfit them for the management or control of property, can do so by depositing money or securities, or conveying real estate in trust to these corporations, the income from which is applied as directed. Those desiring to provide for the support of relatives or dependents, with reversion of the fund, after death of beneficiary, to designated individuals or charities, find them peculiarly adapted to the acceptance of trusteeships under such circumstances. They are also useful where deposits of money or securities are required to be made, to abide the result of litigations, the fulfilment of contracts, or the issue of transactions in the future.

Trust companies are exempted from giving bonds or other collateral security when appointed guardian, receiver, or depository of moneys paid into court; all moneys received by them in either of such characters is at the sole risk of the corporation, and for any loss thereof, their capital stock, property, and effects are absolutely liable, and in case of dissolution by the Legislature, the supreme court, or otherwise, debts due from

them as guardian, receiver, or depository of moneys paid into court usually have preference.

Several of the earlier charters (1822 and 1830) granted by the State of New York, in addition to the numerous other powers conferred, authorized the insuring against losses by fire; the insuring of lives; the granting and purchasing of annuities and the making of any other contracts contingent on the duration of life. Such extraordinary powers were exercised by but one company and for a brief period only. At present the principal business of these corporations is the receiving of deposits and the acceptance of trusts; those engaged in the receiving of deposits in the State of New York, whether domestic or foreign, are required to transfer securities to the amount of ten per cent. of their capital to the superintendent of the banking department in trust as security for their depositors and creditors. These corporations make semi-annual reports of their condition to that officer, and are subject to annual examinations by him.

Trust companies possess the general powers of corporations. On the latitude of their investments there is little restriction other than the discretion of their trustees; they loan on all classes of stocks or bonds having a home or stock exchange market value, and buy almost any good mercantile paper, not being confined to particular branches of business in the purchase of notes. With but few exceptions these corporations are located at the large money centres. Jan. 1, 1888, the capital of the trust companies of New York city alone exceeded \$14,500,000.

In the following table, compiled from both official and unofficial sources, is given the aggregate of the several items of resources and liabilities reported by the loan and trust companies throughout the United States for the years 1886 and 1887:

<i>Resources.</i>	1886-87. 58 companies.
Loans on real estate.....	\$16,269,993
Loans on personal and collateral security.....	36,544,018
Other loans and discounts.....	143,282,819
Overdrafts.....	12,810
U. S. bonds.....	28,787,717
State, county, and municipal bonds.....	178,148
R. R. bonds and stocks.....	7,400,348
Bank stocks.....	132,651
Other stocks, bonds and mortgages.....	36,428,878
Due from other banks and bankers.....	18,795,503
Real estate, furniture, and fixtures.....	11,047,272
Current expenses and taxes paid.....	433,509
Gold coins and certificates.....	} 16,822,224
Silver coins and certificates.....	
Legal tenders and national bank notes.....	} 2,949,767
Checks and other cash items.....	
Other resources.....	2,949,767
Total.....	\$319,125,657

<i>Liabilities.</i>	
Capital stock paid in.....	\$36,355,769
Surplus fund.....	15,841,793
Other undivided profits.....	11,351,526
Dividends unpaid.....	581,255
Individual deposits.....	240,190,711
State, county, and municipal deposits.....	38,084
Due to other banks and bankers.....	5,606,897
Other liabilities.....	9,159,692
Total.....	\$319,125,657 (E. A. W.)

In the State of New York trust, loan, mortgage, security, guarantee or indemnity companies or associations and corporations or associations having the power of receiving money on deposit, incorporated under any law of the State, or corporations or associations not incorporated under the laws of the State which receive deposits of money or assume obligations in that State, other than banks, savings-banks and insurance companies, are on an equality in respect to the supervision the State exercises over them through its banking department.

(E. A. W.)

TRUSTS. The advantages to be derived from the principles of co-operation have in recent times impressed many changes on industrial methods, but none more striking than that exhibited by the great "Trusts" that have come into existence within a few years last past. That individuals may unite their property and exertions for their common benefit has always been recognized by our practice and our laws, although when they assume to act with corporate unity the authorization of the laws is a recognized necessity. Partnerships are the outgrowth of such purposes and in more advanced conditions of social integration a legal corporation makes its appearance, while it is reserved for a still more advanced state of industrial organization to exhibit co-operative groups embracing both individuals and corporations. The stages of this process present the most interesting social phenomena. (See CO-OPERATION and CORPORATION.)

Trusts in the sense of the term here used have existed in Europe for many years, but it was reserved for their transfer to the fertile American mind to produce their most striking effects. The necessity of bringing a series of railroads constituting parts of a particular system of transportation under a common management induced the formation of large "syndicates" for their control. The attempt that had been made to connect their operations by contracts imposing restrictions upon their management or combining their interests proving not to be effectual, proprietary combinations, aided by the functions of syndicates, were the result. This object was accomplished by uniting in the hands of a limited number of persons the major stock interest of each of the roads desired to be brought under a common management. Where the members of the syndicate were the owners of the stock interest that enabled them to assume management of the system the ease was simply a combination among stockholders of a number of roads to exercise the rights they possess as stockholders to secure such management of such roads as might best suit their ideas of their interests. The idea, thus developed in its application to transportation, passed into the field of production.

The immense oil industry of this country attracted the attention of the large operators at first in its bearing on oil transportation, and afterwards extended to the production and refining of oil. (See PETROLEUM PIPE LINES.) So vast an enterprise demanded more than could be accomplished by the union of a limited number of capitalists having personal confidence in each other, and took a more enlarged form. The control of vast amounts of property consisting of oil wells, refineries, and means of transportation were to be centred for their management in the hands of a few men with the largest powers of control over the conduct of the business that it was possible to communicate. If the management was to embrace all the owners of the property, the vast extent of the business would demand that so large a number of managers should be included as to defeat that unity of purpose and action that is essential to the highest success. It was thus necessary that, while the ownership of the property managed should be in the hands of many persons, the control should be in the hands of a very limited number. To bring about this result the management had to be separated from the proprietary interest. Such a relation contained the essential principles of a trust according to which the title and control of property is in one while the beneficial interest is in the hands of another.

In the organization of the Standard Oil Trust in 1882 these conditions were complied with by an arrangement by which the property to be managed was transferred to certain persons termed trustees, but for the benefit of the actual owners whose interests were represented by trust certificates issued by the trustees and which were designed to be merchantable property

capable of being bought and sold in the market. The design appears to have been to place in the hands of the trustees property of partnerships, and the stock of incorporated companies engaged, in the business proposed to be carried on by the trust. The object of this arrangement was to enable the trustees to have the direct management of the property employed in the business by private companies and the indirect control of that held by corporations by having the right to choose directors for its management. This plan embraced several important features; it involved personal confidence in the trustees, who were intrusted with the largest powers of control over the property in trust capable of being communicated to persons standing in a fiduciary relation to its owners; it placed the vast industry in the hands of a limited number of persons whose skill and integrity were approved by a large number of interested persons qualified to understand the requirements of the business and the character of the men to whom it was intrusted. A more vigorous application of the principle of co-operation cannot be conceived.

The immense success of the Standard Oil Trust in embracing within its control almost the entire oil interest of the country attracted the attention of operators in other fields, and induced in 1884 the formation of the Cotton-Seed Oil Trust that has developed into a vast industry. Many other trusts have followed these examples, the most notable being the Sugar Trust.

It is supposed by many that these great trusts are in their constitution and operation out of harmony with the principle of our legal system. Others emphasize their conflict with competition, which seems to impress their minds as being the leading if not the only principle of the industrial system. A very general feeling prevails outside of the owners of the stock certificates that the powers placed in the hands of the trustees are too great for any class of men to exercise, whether they use them well or ill.

An intelligent view of trusts must distinguish among them and recognize very marked differences in structure and operation. Those trusts that deal with trade alone, independent of production and transportation, cannot in the nature of things have any other object than to stifle competition by direct action upon that principle. Such an attempt when accomplished by co-operation is condemned by our laws, in harmony with the principle of industry that the destruction of competition is not the proper function of co-operation. To aggregate capital for the purpose of trade is certainly legitimate, and to secure such aggregation of capital by uniting the means and exertions of a number of persons has always been regarded as conformable to both political and economic laws, as is apparent from the universal recognition of partnerships which are an instance of this class. While co-operation has a legitimate place in the operations of trade, it is an abuse of that function to employ it as means of stifling competition, and it is true that, whenever two or more persons unite for the purpose of trade, there is an indirect interference with competition, for had they traded separately there would have been competition between them, but if this is not the intended effect but an incidental consequence merely, the combination is not improper. An attempt to stifle competition in trade is then a wrong, whether committed by individuals trading together or by companies, whether organized on the principles of trusts or otherwise.

That trusts for such improper purposes have been created and have brought a bad name upon trusts in general is certainly true, and without doubt trusts organized for legitimate purposes have engaged in such transactions, but the question presented in such cases is not that of the legitimacy of trusts, but of the lawfulness of their conduct. The scarcity of commodities of general necessity is a social evil, and it takes no great penetration to discover that there are appropriate social means for preventing such an evil from

being intentionally created for the benefit of persons combining together to accomplish such a purpose. The legal principles that have led to the repression of such combinations are those just indicated, and their applicability to suppress such improper combinations cannot be affected by the form with which such combinations may be clothed. Where the object of a trust is an unlawful act the trust is incapable of being regarded other than as an unlawful combination, and that such trusts exist does not admit of question; many of the trusts that have brought discredit on the system are not only of this class but present most dangerous instances of such unlawful objects. Such trusts have been created to monopolize the food supplies of great cities like New York, and affecting as they do the necessities of life are deserving of the strongest condemnation.

The most interesting question as to trusts is not concerned with this class just indicated, but relates to such as tend to supply the means of production and transportation. While the trust that is merely a disguised attempt to monopolize trade must be judged according to its real rather than its pretended purpose, one that is actually intended to afford larger and better means of production and transportation must be judged by different principles. Such trusts may indirectly diminish competition, but if this is the incident or accident of their existence, their character is not to be determined by that fact.

It is the undoubted right of any number of persons, great or small, to combine their interests for purposes of controlling means for production, even although they should be able to grasp in their control the industry of the continent, and to deprive them of that liberty is to make an encroachment upon individual liberty as it is understood at this day in all free countries, while it is true that if the necessary consequences of such liberty should impair the social interests, it would be legitimate to place it under legal restraint, yet before such a step is taken its necessity should be demonstrated and not merely anticipated. If it is a right of individuals to co-operate thus, it is equally their right to repose the conduct of their interests in any person or persons in whom they may desire to place that degree of confidence. Whether they own factories or the stock of such as are incorporated, they have an equal right to unite with as many others as may choose to join with them and to commit the management of such property to persons of their own selection. The disposition that may be made by a stockholder of a corporation of his stock is no more the subject of legal control than is any other kind of property, and if he chooses to unite with others to use it as capital in productive enterprises he is at entire liberty to do so under our laws.

Whether viewed as a question of law or of economy, no limit has as yet been found to the possible aggregation of capital for industrial purposes; and if there is such a limit ascertainable, it has not been discovered by the experience of mankind; and unless such a limit is found and ascertained by laws, there can be no difference between the case of a single person trusting the management of his property to one in whom he has personal confidence and the case of such trusts on the part of any number of such persons.

The reduction of the number of persons producing a commodity has no necessary tendency to diminish the amount of that commodity produced, provided the reduced number have the means and desire of maintaining the supply, while, on the other hand, the less the number of persons producing a given amount of a certain commodity, the less should be the cost of its production. Over-production is a social evil, for although it may afford momentary gratification, yet in the end it will react against the social interests. Such a concerted management of an industry as will tend to prevent over-production must be regarded as a social advantage, and the organization of an industry as a

whole and bringing it under unity of control has a tendency in that direction. If this tendency is counteracted by other causes tending to unduly restrict production where there is concerted management of productive interests, that fact is yet to be demonstrated by actual experience. The tendency of social development seems to lie in the direction of the integration of industrial powers, and it is not yet clear where is to be the limit to such tendency, and to assume to fix an arbitrary limit before the true limit is ascertained is a step that no intelligent statesman will take.

The existing popular discussion of the question of suppressing or limiting the great trusts is of too excited a character to reach a safe conclusion. The conflict of individual interests has a conspicuous place in such discussion, and is not a proper element of the question as one of public law and policy. The concentration of capital necessarily displaces for the time being individual advantages, and causes popular opposition to new and advanced conditions. In the present instance this cause is more energetic from the influence of a widely extended opinion and feeling that the object of social arrangements should be to enhance the powers of the individual by a corresponding decrease of the influence of corporate and aggregate masses. It is not to be expected that a safe solution of either the theoretical or the practical question suggested will be reached while these elements are combined in public discussion.

If it is perceived that the principles that have been stated in relation to productive industries are sound and applicable to the case, it will readily appear that they are of equal force in their application to the conditions of transportation. Although trade and transportation are embraced in the distributive function that intervenes between production and consumption, still they are separated by distinct principles. That railway transportation demands concentrated management is generally admitted, many persons believing that that need cannot be satisfied otherwise than by placing the entire system in the hands of the government, while others regard that end as attainable by combined individual efforts.

It is equally true of transportation as of production, that the proper relation between supply and demand is a social need, and that it can be better reached by concerted management than by ordinary competition. What has been said of productive industry on this subject needs no demonstration as to its applicability to the case of transportation.

It must be conceded by every intelligent thinker that dangers attend the existence of great powers, increased with the increasing magnitude of those powers. Our experience with steam at high pressures and with electricity demonstrates this fact, and that such dangers are incapable of being separated from the conditions of material progress. When it is ascertained how far the development of material resources should be permitted to go, a limit of the measure of the productive powers can be determined, but not until that time arrives can such limitations be intelligently imposed. America has the rôle of competition with Europe under conditions that render the highest organization of its productive powers a necessity and cannot afford to weaken the sources of its strength, and should not be hasty in imposing political restraints upon the free exercise of its productive powers.

If the great trusts confine their operations within the limits of a wise administration, they may prove to be a great step in advance of the realizations of industry in the past; but if they abuse their powers and seek to inconvenience rather than to serve the community, the failure of the system will be due to their own fault, and in the meantime the policy of the country is to keep them within the line of their proper function, and not to impair or destroy their useful powers. (See CORPORATION.) (A. J. W.)

TRUXTON, THOMAS (1755-1822), naval officer, was born Feb. 17, 1755, at Jamaica, Long Island. At the age of 12 he went to sea and was impressed on board a British war-ship. In 1776 he was lieutenant of the privateer Congress, and next year was commander of the Independence and, in company with two consort, succeeded in making many prizes. On the conclusion of the war of independence he engaged in mercantile pursuits, trading between Philadelphia and the West Indies. In 1791 he was promoted captain of the West Indies squadron and given command of the frigate Constellation, on board of which he did efficient service during the trouble with France, in Pres. Adams' administration. In especial, in January, 1799, he captured, off St. Kitts, *L'Insurgente*, the swiftest craft in the French fleet, for which exploit he received a service of plate from the merchants at Lloyd's. Next year he encountered the French frigate *Vengeance* off Guadaloupe and drove it, in a hopelessly damaged condition, into Curaçoa. But for the fall of his foremast he would have captured her. For his gallantry here Congress voted him a gold medal. In 1801 he was promoted commander of the West Indies squadron and transferred to the President. In 1802 he was named to command the expedition against Tripoli, but being denied a captain to his flagship he declined to accept and Jefferson struck his name off the navy-list. He now retired to private life in Philadelphia, where he occupied the position of high sheriff from 1816 to 1819. He died May 5, 1822. He was author of a work on *Latitude and Longitude* (1794), and compiler of a volume of extracts on *Naval Tactics* (1806).

TSCHUDI, JOHANN JAKOB VON, Swiss naturalist and traveller, was born July 25, 1818, at Glarus, Switzerland, of a family distinguished for talent in many directions. For its earlier members of note see the ENCYCLOPÆDIA BRITANNICA. He studied at the University of Zurich, and afterwards at those of Leyden, Paris, and Berlin, devoting himself chiefly to the natural sciences and philology. In 1838 he set out on a French ship with the view of making a journey round the world, but the captain having sold the vessel at Callao, he was compelled to restrict himself to an investigation of the natural history and ethnography of Peru, which he pursued for five years. On his return to his property at Jakobshof in Lower Austria, he devoted some years to the arrangement of his materials to supply the leading museums of Europe. In 1857 he undertook a second journey to Brazil, the Argentine States, Chili, Bolivia, and Peru, returning in 1859, when he was almost immediately sent back by the Swiss government as its minister extraordinary to Brazil. During the two years he acted in this capacity he directed his attention particularly to the capabilities of the country as a field for immigration. In 1868 he was appointed plenipotentiary to Vienna and remained there till 1883, when he returned to his property. Among his works on natural history are his *System de Batrachier* (Neuchâtel, 1838), and *Untersuchungen über die Fauna Peruanus* (St. Gall, 1844-47). His philological works comprise *Die Kechua Sprache* (Vienna, 1853); *Ollanta*, an old Peruvian drama translated out of the Quechua tongue and annotated (Vienna, 1875), and his elaborate *Organismus der Kechuasprache* (Leipzig, 1884). His works of travel, embodying his observations in Brazil, the Argentine Republic, Chili, Bolivia, and Peru, are of great value, and have been translated into English. He has also published a number of papers on natural history, medical, geographical, and ethnographical subjects.

TUCKER, ST. GEORGE (1752-1827), jurist and founder of an influential Virginian family, was born in Bermuda, July 9, 1752. His father came to Virginia while St. George was yet a boy, and he entered William and Mary College, where he graduated in 1772. He afterwards studied law, which he administered as a

magistrate almost from his admission to the bar. On the outbreak of the war of independence, he left the courts and took up arms for his adopted country. His chief exploit was a secret and successful expedition to Bermuda, where he knew there was a large quantity of military stores in a fortification slenderly garrisoned. These stores eked out the slender supply of Washington's army in the siege of Boston. Tucker was with the army before Yorktown in the capacity of lieutenant-colonel, and received a wound in the face from the explosion of a bomb. He was soon after appointed to a seat in the General Court, and, while a judge, was professor of law in William and Mary College. In 1803 he was advanced to judge in the State Court of Appeals, holding the office for 8 years; in 1813 he became judge of the U. S. Court for the eastern district of Virginia. He took part in codifying the laws of his State, and was one of the commissioners of Virginia who met in Annapolis in 1786 and recommended the convention that formed the present Federal Constitution. In 1778 he married his first wife, Mrs. Randolph, mother of John Randolph of Roanoke, by whom he had numerous descendants, not a few of whom have risen to eminence. His second wife left no children who survived him. Judge Tucker had a ready talent for versification which he exercised through life, being particularly successful in *vers de société*. To his annotated edition of *Blackstone's Commentaries* (1803) is probably due his sobriquet of the "American Blackstone." He was also the author of *A Dissertation on Slavery, with a Proposal for its Gradual Abolition in Virginia*. He died in Nelson county, Va., in 1827.

His son, HENRY ST. GEORGE TUCKER (1781-1848), was born in Virginia, Jan. 5, 1781, studied law under his father and became like him eminent in his profession. He was professor of law in the University of Virginia, and chancellor of the fourth judicial district and president of the State Court of Appeals. From 1815 to 1819 he was a member of Congress. His works include *Lectures on Constitutional Law; Commentaries on the Laws of Virginia* (2 vols., Winchester, 1836); and *Lectures on Natural Law and Government* (Richmond, 1843). He died at Winchester, Va., Aug. 28, 1848.

Another son, NATHANIEL BEVERLEY TUCKER (1784-1851), was born at Matoax, Amelia co., Va., Sept. 6, 1784. Graduating at William and Mary College, he studied law, and commenced practice in 1809 in Charlotte co., but removed in 1815 to Missouri where he became a judge, retaining office till 1839. In 1834 he was called to the chair of law in William and Mary College, and held this position till his death, which occurred at Winchester, Aug. 26, 1851. In 1850 he had attended the Southern convention at Nashville, and in discussing the alleged wrongs of the South delivered an elaborate invective which recalled the speeches of his half-brother, John Randolph of Roanoke. His friend, W. Gilmore Simms, has well described him as "a brave old Virginian gentleman, a stern States Rights doctrinaire, intense of feeling, jealous of right, and with an eager sense of wrong and injury." Judge Tucker's legal works include a treatise on *Pleading* and *Lectures on Constitutional Law*, which are still of value as giving clearly and forcibly the States Rights view. Besides these he was the author of three novels, *George Balcombe*, *Gertrude*, and *The Partisan Leader*. The last, secretly printed in 1836, but purporting to have been written in 1856, has a special interest as in some measure foreshadowing the secession movement. It represents Van Buren as in 1849 holding a third presidential term, at the head of a strongly centralized government. The Southern States, however, except Virginia, have seceded; the Constitution having been set at naught, the Union has been dissolved, and a conflict of small republics ensues. These were depicted as the legitimate consequences of the continuance of Van Buren's ad-

ministration, and though strangely at variance with the actual facts, reveal the ideas then germinating in the leading classes of the South. The story was reprinted in New York in 1861 with the title, *A Key to the Disunion Conspiracy*.

GEORGE TUCKER (1775-1861), a nephew of St. George Tucker, came to Virginia from the Bermudas about 1787, entered in William and Mary College, and was educated in law by his uncle. He was elected to Congress in 1819, 1821, and 1823, and in 1825 became professor of ethics and political economy in the University of Virginia, which position he held till he reached his 70th year. The most important work that came from his pen was a *Life of Thomas Jefferson* (1837), which was long a standard authority. He was the author also of a novel entitled *The Valley of the Shenandoah* (1824); and *A Voyage to the Moon* (1827), a satirical romance. His *History of the United States* (4 vols., 1856-58) brought the narrative down to 1840. The most of his later life he spent in Philadelphia, but he died near Charlottesville, Va., April 10, 1864.

TUCKERMAN, HENRY THEODORE (1813-1871), man of letters, was born in Boston, April 29, 1813, and educated in the public schools there. The years from 1833 to 1839 were spent in European travel for the sake of his health, with the exception of parts of 1835-36, when he returned to resume his studies. The fruits of his tours are seen in his *Italian Sketch-Book* (1835); *Isabella of Sicily, a Pilgrimage* (1839); *Rambles and Reveries* (1841), with which may be associated his later *Month in England* (1853) and *Maga Papers about Paris* (1867). Removed from Boston to New York in 1845. He contributed there largely to magazines, reviews, and other periodicals. In 1846 the first series of his contributed papers appeared in collected form under the title, *Thoughts on the Poets*, and they were followed by *Artist Life, or Sketches of American Painters* (1847); *Characteristics of Literature* (1849-1851); *The Optimist* (1850); *Diary of a Dreamer* (1853); *Essays, Biographical and Critical, or Studies of Character* (1857). Of this last volume Washington Irving, with characteristic kindness to a brother author, says: "I do not know when I have read any work more uniformly rich, full, and well sustained." In biography proper he produced the lives of Commodore Silas Talbot, Horatio Greenough, Dr. J. W. Francis, J. P. Kennedy. Part of his essay on *The Character and Portraits of Washington* (1859) was originally appended to Irving's *Life of Washington. The Book of American Artists* (1867) is still a standard work, and, with his other writings on art, furnishes his best claim to remembrance. While steadily diligent with his pen, he was always somewhat of a dreamer, and the ideal unworldly life of the artist had especial charms for him. To Shaw's *Outlines of English Literature* Tuckerman appended a *Sketch of American Literature* (1852). His pamphlet on *The Rebellion, its Latent Causes and True Significance* (1861), was pronounced by Dr. A. P. Peabody "a very thorough and careful analysis of certain secondary causes of the Rebellion." Among his other publications are *America and her Commentators* (1864) and *The Criterion: or the Test of Talk about Familiar Things* (1866). Tuckerman also produced *The Spirit of Poetry* (1851) and *A Sheaf of Verse*, the latter a contribution to the Sanitary Fair of New York in 1864. His books are mainly collections of monographs relating to biography, literature, and art. As specimens of genial and pleasantly instructive, but not profound, criticism they served well a temporary purpose, though now less frequently read or quoted. The author deserves credit for his genuinely American spirit.

TUCSON, a city of Arizona, county-seat of Pima co., is on the Rio Santa Cruz and on the Southern Pacific Railroad, 250 miles E. of Yuma. It has a court-house, U. S. government building, a bank, a church, public and private schools, and a newspaper

office. It carries on trade in hides, stock, wool, and gold-dust. It was founded by the Jesuits in 1560, and was the capital of Arizona from 1867 to 1877. Its population in 1880 was 7007.

TUFTS COLLEGE is situated on the most beautiful and commanding eminence in the southeasterly part of Middlesex co., within the town of Medford and on the borders of Medford and Somerville, Mass. The tract of land given by Mr. Charles Tufts comprises in all 100 acres. In consequence of this gift it was determined that the college should bear his name. The original charter, granted April 21, 1852, conferred the power to give degrees of every kind "except medical degrees." This restriction was removed Feb. 2, 1867. In May, 1853, the Rev. Hosea Ballou, D. D., was chosen to the office of president. The college was first regularly opened to students in August, 1855. Dr. Ballou died in May, 1861. The Rev. A. A. Miner, D. D., was chosen to succeed him in 1862, and continued to hold the office until his resignation in February, 1875. During his presidency and largely through his instrumentality the extraordinary material development of the college was secured. Funds were obtained from Silvanus Packard, William J. Walker, Oliver Dean, and others, aggregating fully \$750,000. The Hon. Israel Washburn, Jr., the war governor of Maine, was chosen president on the resignation of Dr. Miner, but he declined to accept the office. The trustees then determined to place an alumnus at the head of the institution. The present incumbent, the Rev. Elmer Hewitt Capen, D. D., a graduate of the class of 1860, was elected to the vacant chair, March 13, 1875. The calling of an alumnus to the post has quickened the interest and secured the co-operation of the graduates.

In the matter of development few institutions in the country have made steadier progress. The selection of its present site was fortunate: first, because of its proximity to Boston, the literary centre of the New World; and, secondly, because of the closeness of its proximity to Harvard University, which has compelled it to maintain the highest standard. The result is seen in the steady growth of recent years. The attendance has increased about forty per cent. during the last decade.

The course of study adopted was that of the other leading New England colleges. The faculty in the beginning consisted of three professors besides the president; and for some years the work was done by not more than five teachers. The gifts of Dr. Walker enabled the trustees to enlarge on the side of science. A professorship of civil engineering was created in 1867. This department has been enlarged gradually, until now men receive complete courses of professional instruction in civil, mechanical, and electrical engineering. Natural history, physics, and chemistry have each been made separate departments. There are excellent laboratories of physics, and, besides college work, original investigations are conducted by Dr. Dolbear and assistant-professor Hooper. The organic research laboratory of chemistry has been fully equipped and offers facilities unsurpassed for original investigation. Very considerable additions to chemical knowledge are made every year by Prof. Michael and his assistants.

Previous to 1875 the work of the college was mainly prescribed. At that time the scope of electives was broadened. There are now 11 full courses of electives open, and from the middle of junior year a large percentage of the work is in lines which the student chooses for himself. A system of honors has been devised to reward students eminent in special lines of work. The degree of A. M. is given only after graduate study in residence or under the direction of the faculty for at least one year. The modifications of discipline have been no less important. Formal rules relating to conduct have been abolished. Men are put upon their honor and no longer watched. Under

this policy the moral tone of the college has greatly advanced. The contentment of students has also increased. The relative percentage of those who graduate to those who enter has risen from 63 per cent. to nearly 80 per cent., placing it in this respect in the front rank of New England colleges. The whole number of graduates is now about 500.

Silvanus Packard by will provided for one theological professorship. Thomas J. Sawyer, D. D., was elected Packard professor of theology and the divinity school organized and opened in 1869. There are at present four professors in the divinity school besides Dr. Sawyer. The course of study is four years for all except college graduates.

The site of the college was originally treeless and barren. But imposing buildings have been erected, walks and driveways have been constructed, and trees have attained a thick and heavy growth. There is no more attractive spot in the neighborhood of Boston. In 1883 Mrs. Mary T. Goddard erected at her own cost a beautiful stone chapel, and on its completion built and furnished an excellent gymnasium. One of the most important additions of recent years is the Barnum Museum of Natural History, the gift of Mr. P. T. Barnum. It is a building of dignity and beauty. The first floor is devoted to laboratories and work-rooms. The main floor has a lecture-room and a grand vestibule in which the larger specimens of natural history are deposited and where the stuffed skin of Jumbo is to find its ultimate resting-place. The third floor comprises a large exhibition hall for the cabinet, together with the fine zoological collection given by Mr. Barnum. The library contains nearly 25,000 bound volumes, many of them rare and of great value, and 8000 or 9000 pamphlets.

The college has been distinguished for its liberal policy towards young men who are obliged, on account of limited means, to struggle for an education. There are thirty scholarships in the gift of the college. By means of these tuition may be cancelled. Grants are also given, in cases of need, so that instruction is practically free to men of promise and fidelity whose circumstances require it. On account of the isolation of the college, there being no villages in immediate contact with it on either side, it is not only extremely favorable to study, but admirably adapted to those who are obliged to practise economy. (E. H. C.)

TULIP TREE, or TULIP POPLAR, the common name given to the *Liriodendron tulipifera*, a genus of trees belonging to the order *Magnoliaceæ* which has but one species, that above named. It is a native of the United States, where it is generally known as a poplar from its resemblance to the latter, though it has no affinity to the poplars. It is known as white wood and yellow poplar, from its varying color; as canoe wood, from the use made of it by the Indians; and as saddle tree, from the shape of its leaves. It is one of the most magnificent of American deciduous trees, being only surpassed in size by the plane or butternut, and being superior to the latter in the perfect straightness and uniform diameter of its trunk, the more regular distribution of branches, and the greater richness of foliage and flowers. Its height is usually 60 to 80 feet, with a diameter of 18 inches to 3 feet, but in favorable localities it may attain a height of 120 to 140 feet, and more than 7 feet diameter. The leaves of this tree have a peculiar development. As the large buds open, the leaf group is found to be covered by two stipules cohering at their edges so as to form a sac. On opening they reveal an interior sac of the same character and a single leaf closely folded and with the petiole doubled over. As this leaf unfolds the interior sac opens, revealing similar conditions within, and this process continues until 5 or 6 leaves have appeared. The leaves are 6 or 8 inches long, on long petioles, with four lobes, the apex appearing as if abruptly cut off, leaving a very broad, shallow notch. This conformation of the leaf gives a

peculiar appearance to the tree, clearly distinguishing it from all others. The flowers are equally peculiar and striking. They have 3 deciduous sepals and 6 petals, forming a large lily or tulip shaped flower, from which resemblance both the generic and specific names have been derived. The flowers are solitary and terminal, enclosed by a sheath which is pushed off as they open. The flower bell is 2 inches or more in length, with numerous stamens and a cone-like mass of pistils. The petals are greenish-yellow in color, with an orange spot at base, the color deviating in different localities. They form large, showy flowers with an agreeable odor and much nectar, which when in bloom add greatly to the ornamental character of this handsome tree. The fruit comprises numerous thin scales attached to a common axis and forming a conical spike 2 or 3 inches long.

The range of the Tulip tree is from the Southern extremity of Lake Champlain to the Gulf States, and from the Connecticut River to the Mississippi Valley, being abundant in the Middle and Western States, and particularly so in Kentucky. It delights in deep, loamy, and extremely fertile soils, like those of rich river bottoms and swamp borders, but will grow on soil of different character. The wood, though classed with the light woods, is much heavier than the common poplar and has almost as many uses as the white pine. It is easily worked, polishes well, and the heartwood when well seasoned resists decay and is rarely attacked by insects, but is liable to shrink and warp when exposed to the weather. Its color and character are so affected by the nature of the soil that it is known in some localities as white, in others as yellow poplar. Near New York and Philadelphia it was formerly much used for joists and rafters, but has grown scarce and has been replaced by pine and spruce. It is also used for door-panels and wainscots, and particularly for carriage-panels, it taking the paint well and polishing brilliantly when perfectly dry. Large quantities are used in trunk-making, for chair-seats, and for tables and beds (stained to imitate mahogany). Of other uses may be named the making of sleigh- and wagon-bodies, bowls, brush- and broom-handles, and various other articles of turners' ware. The Indians used it to form canoes, the wood being light and strong, while from the great length and diameter of the trunk single canoes could be made capable of carrying 20 or more persons. The bark, especially of the root, is bitter and aromatic, and is considered by some as scarcely inferior to cinchona as a tonic and antiseptic. The aromatic principle resides in a resin, which acts as a gentle cathartic. The bark was used by the Indians as a remedy for intermittent fevers. Reduced to powder and given to horses it seems a pretty certain remedy for worms. (C. M.)

TUNNELS IN AMERICA. This country has several prominent examples of tunnels See Vol. XXII. through mountains for railroad and p. 622 (p. 662 mining purposes, and has also begun to Am. Rep.). use tunnels under the beds of navigable rivers. In the first class the Hoosac tunnel is the most noted. The Hoosac Mountain is a part of the Green Mountain range that extends across the western part of Massachusetts. On account of the very circuitous routes which it compelled to be taken between Boston and Albany, and the West, the project of a shorter communication was seriously debated in the early part of the present century. At that time canals were in vogue, and in 1825 the State of Massachusetts appointed a board of commissioners to select a route for such canal to connect Boston with the Hudson River. Their report included the project of a tunnel through the Hoosac Mountain. But when soon afterward the early railroads of America proved successful, the scheme of building a canal was abandoned. The Boston and Albany Railroad was completed in 1842; it was carried over the mountains about 20 miles to the south of the proposed tunnel. The steep grades of

this road had been attempted by no road up to that time; and even yet the running expenses and freight charges are higher than they would be with lower grades. On this account the project of the tunnel was still considered seriously even after the canal had been abandoned. In 1848 the Troy and Greenfield Railroad Company was incorporated with the object of building a road through the mountain. The most eminent geological authority of that day, Prof. Edward Hitchcock, of Amherst College, examined the mountain, and stated that quartz and mica slate were the chief substances to be encountered. In 1851 the work upon the tunnel was commenced with a clumsy and expensive boring machine, which attempted to bore a hole of the full size of the tunnel. When this and similar machines had proved failures the work was abandoned until 1854. The State of Massachusetts then loaned \$2,000,000 and took a mortgage on the property of the company as security. From this source funds were obtained until 1862, when the work, again stopped, and the State foreclosed the mortgage. The State having committed itself to the work commissioners were appointed to carry it on, but on account of its slow progress the State, in 1868, made a contract for its completion. At that time the work was in the following condition: East end, 5283 feet; west end, 4055 feet; west shaft sunk to grade, 318 feet, and central shaft sunk to a depth of 583 feet. The contract required the completion of the additional 15,743 feet, the central shaft to be sunk to grade, and the sum to be paid, \$4,594,268. The work was successfully prosecuted; and on Feb. 9, 1875, the first railroad train passed through the Hoosac Mountain.

Down to 1865 the drilling and blasting had been done by old methods; after that date the State commissioners used machine-drills driven by compressed air, as had been successfully done in the Mont Cenis tunnel under the Alps. For using compressed air sufficient water-power was obtained at the east end; while the central and west end sections were carried on with steam-power. The first drills were heavy and expensive; and later a less complicated and lighter machine, with a gang of drills, was used. With this machine a hole of from 4 to 5 feet in depth could be made in an hour; and one of the drills was kept running for over 3 months without the slightest repair, during which time the total depth of holes drilled would have measured over a mile in length. The compressed air was stored in a tank and conveyed to the tunnel through 12-inch iron-pipes carrying a pressure of about 60 lbs. to the square inch. A rubber-pipe, easily disconnected when the drill-carriages were taken out of the way of a blast, connected the iron-pipes with the drills. A heading, 8 feet high by 24 feet wide, was driven by the first gang. About 500 feet in the rear of this another gang was employed in enlarging the tunnel to the full size of 22 by 24 feet. The average number of men employed was from 500 to 800, and 136 lives were lost during the construction. Work was carried on continually night and day, with the exception of Sundays. Down to 1865 the chief explosive was the ordinary black powder; but after that date nitro-glycerine was used for a short time, and it was finally decided to use trinitro-glycerine manufactured upon the spot. The central shaft, located near the centre of the tunnel, is 1028 feet deep. This was sunk not only as a ventilator, but also as a means of shortening the time of the work by allowing other gangs to work east and west from its bottom. After sinking to the tunnel-grade an advance was made to the west of 2006 feet, and to the east of 1563 feet. But so much water poured into the tunnel that it is doubtful if much time was saved in this way. After the sinking of the central shaft it was thought best to sink a shaft toward the western entrance, on account of the uncertain structure of the rock in that part of the tunnel. This also helped to shorten the time of the work. After the tunnel had been projected monu-

ments were built upon the points of the two highest summits overhead. The transit instrument threw these monuments in line and extended the line in either direction for several miles. This not only furnished the line upon which the tunnel was constructed, but also the line by which the central and western shafts were sunk. When the headings from the central shaft and from the eastern opening came together their alignments swerved from each other by only $\frac{1}{8}$ inch; whereas, the opposite arms of the Mont Cenis tunnel had a divergence of more than half a yard.

The tunnel cost the State of Massachusetts, with interest on the investment, about \$18,000,000; but the cost would not have been so great had the improved methods of machinery and blasting been used earlier in the progress of the work. The first plan for the use of the completed tunnel was to allow all railroads to have equal rights; but this was soon abandoned, and special privileges were given to one line. After several years of unsatisfactory dealing the State of Massachusetts, in January, 1887, completed the sale of the Hoosac tunnel, with the accompanying 44 miles of railroad, to the Fitchburg Railroad Company for \$5,000,000 in bonds and \$5,000,000 in stock of the railroad.

In June, 1888, a tunnel was opened through the Cascade range in Washington Territory. The work was begun in April, 1886; the material and machinery were hauled in wagons for over 90 miles through a rough country without roads; some of the heavy machinery was moved by block and tackle the whole distance, and \$125,000 had been expended before the actual work began. The tunnel is 9850 feet long and 16 feet wide by 20½ feet high in the clear. It is intended for a single-track road. The west end approach consists of an open cut through trap-rock, while the east end enters the tunnel by crossing a creek immediately under a cataract, which has a fall of 160 feet. Before crossing this creek the track is made by cutting a heavy ridge or slide of earth and loose rock. These two approaches contained in the aggregate upward of 30,000 cubic yards of material, most of which was solid rock, requiring to be blasted. The strata or formations of the mountain lie nearly flat, having but a slight inclination from east to west across the entire range. This increased the danger and difficulty of the work. The rock throughout was a gray conglomerate basalt of medium hardness, but slacking and sealing on exposure to air, rendering timbering necessary. The work was constantly prosecuted from both ends with the most approved machinery; one of the air compressors was run by water-power, and the other by steam. The tunnel was run without the use of air-shafts.

Tunnels for mining purposes are less frequent than railroad tunnels. They are used to reach deposits of gold and silver, and also to drain the mines. One of the more recent enterprises is the Big Bend tunnel of Butte co., Cal. Certain points in the valley of the Feather River having been found to be unusually productive of gold, it was considered most desirable for economy's sake to connect these points. To this end a tunnel was commenced in 1882, and completed in 1887. It practically diverts at will the whole of the river from its present channel, and carries it through a mountain. Six gates of iron and steel, each 4½ by 8 feet, at the head of the tunnel, control the passage of the water. The size of the tunnel is 12 by 16 feet, and the length is over 2 miles.

River Tunnels.—Small tunnels under navigable streams are quite frequent in the United States. In Chicago a number have been bored under the Chicago River in order to connect the several parts of the city without bridges. The project of a tunnel under the Detroit River, through which railroad traffic should be carried without interfering with navigation, has long been discussed. Various towns have, from time to time, been selected as sites for the beginning of operations.

At Port Huron, some miles above Detroit, the River St. Clair is now being tunneled in order to avoid the carrying of cars upon railroad ferry-boats. When completed, the tunnel will shorten the distance between Buffalo and the cities of Detroit and Chicago. It will be over a mile in length, 2310 feet being under the river, 1810 feet under dry ground south of the city limits of Port Huron, and 1160 feet on the Canadian side; 1500 feet of the portion under the river will be almost level, falling eastward only enough to cause the water that leaks into the tunnel to run to the Canadian side. The total length of the ascent on the American side will be 4900 feet, and on the Canadian side 4970 feet. The length of the open cutting or approach at the Port Huron end of the tunnel will be 2820 feet, and at the Canadian end 3270 feet. The depth of the lowest part of the tunnel below the surface of the water will be 81 feet, which is 15 feet higher than had been at first expected, on account of anticipated quicksands and water-pockets. The minimum depth of the top below the bed of the river will be 15 feet. The tunnel has a clear internal diameter of 20 feet, and is intended for a single track. A double-track tunnel was at first proposed, but it was found that two single-track tunnels could be built at less expense than one double-track. Should this tunnel prove successful and profitable, the company intends to build a second one. The cost of the tunnel is estimated at \$1,500,000.

There have been various projects of tunnels around New York city. One passing under the East River is projected between Grand Street and the eastern district of Brooklyn; in another, from Long Island City, the eastern entrance of the tunnel would be nearly $\frac{1}{2}$ mile from the river, and the western terminus near Tenth avenue and Thirtieth street. The depth below the surface of the water would be about 100 feet, rising to the surface under either city at an inclination of about 60 feet to the mile. The intended width of the tunnel is 27 feet and the height 21 feet. A double-track road will be laid, each track to be a continuous rail, to prevent noise and jarring. The proposed trains are to be operated by electric motors, and the tunnel lighted by electric lights and ventilated by steam-fans. At each station elevators capable of holding 100 passengers would connect with the surface and elevated railroads.

Another tunnel is proposed under the Harlem River, at the northern end of New York city, in order to avoid the delay occasioned by the opening of the draw-bridges. The construction of this tunnel presents, from an engineering point of view, few difficulties. As the depth of water at the maximum is 30 feet, there would be but 54 feet of vertical altitude to be overcome in the gradients of the tunnel approaches, and this could be done by a grade of 200 feet to the mile which would be perfectly practicable for the use of horse-cars and teams. Ten feet is considered sufficient headroom for the tunnel, as has been ascertained in the Chicago experience. But although a grade of 200 feet to the mile is of no serious moment in the operation of horse-power, yet in the case of steam-railroads, especially those which transport heavy freight, high grades add to operating expenses in a largely increasing ratio. To lessen this grade to a more practicable one, the approaches would have to be carried back a long distance, which would greatly increase first cost and would introduce other difficulties.

The project of connecting New Jersey with New York city by a tunnel has often been discussed, because it would facilitate the passage to Philadelphia and other important points. The tunnel started under the Hudson in 1874-5 by Col. Haskins, of New York, was abandoned after the expenditure of over \$1,000,000. Although the Pennsylvania Railroad Company has control of the charter under which this tunnel was to be constructed, and which gives the owner the right to go underground to any portion of New York or Brooklyn, the old tunnel will not be utilized. By a new project

the underground work will be upon different principles, and will comprise two single-track tunnels. As the expense of this operation will be stupendous, it is proposed to make all railroad lines entering Jersey City parties to it. The plan contemplates terminals, under Washington Square, in New York city, at a depth of 15 feet below the earth's surface, which will occupy an area of over an acre of space. This will be illuminated by electricity and furnished with every convenience and comfort for travellers. There is an evident tendency toward the introduction of underground railroads in the larger American cities, and it is probable that in a few years some of the various schemes proposed for passenger and freight railroads of this character will be successfully executed. (F. G. M.)

TUPELO. See GUM TREE.

TUPPER, MARTIN FARQUHAR, author, was born in London, July 17, 1810, and educated at the Charterhouse, and at Christ Church, Oxford, graduating 1832. He was called to the bar at Lincoln's Inn, but never practised, and has lived on his estate of Alburg in Surrey. His literary career began with an anonymous volume of poems in 1832. His reputation was made by *Proverbial Philosophy* (1838), which the *Athenaeum* thought not "likely to please beyond the circle of a few minds as eccentric as the author's." The critic was mistaken; of this and the second series, 1842, the hundredth thousand was issued in London, 1865, and more than half a million copies have been sold in America. The book has had the honor of several French translations. A third series appeared 1867, and was denounced by the *Athenaeum* as "weak, twaddling, and insincere, not sharp or clear, but serpentine, flabby, and obscure." Mr. Tupper's other works are very numerous but less notable: they include several novels. *The Crock of Gold* (1844); *Heart* (1844); *The Twins* (1844); and *Stephen Langton, or the Days of King John* (2 vols., 1858); of miscellaneous prose, *Modern Pyramid* (1839); *An Author's Mind* (1841); *Probabilities* (1847); *Farley Heath* (1851); *Paterfamilias' Diary* (1855); *Memorials of W. G. Tupper* (1856); and *Rides and Reveries of the late Mr. Æsop Smith* (1857); and in verse *Gerulldine* (1838); *A Thousand Lines* (1845); *Uactens* (1848); *King Alfred's Poems in English Metres* (1851); *Hymns for all Nations* (translated into 30 languages, for the World's Fair, 1851); *Lyrics* (1854); 300 *Sonnets* (1860); several volumes of ballads, a few odes, etc., and two plays, *Alfred* (1865) and *Raleigh* (1866). The *Times* in 1870 accorded him the long established "position of chief butt for metropolitan critics and professional jokers;" but the *Literary Gazette* in 1848 called him "a genuine poet and an original thinker," and his admirers proposed a testimonial in 1867. Mr. Tupper's life has been uneventful; he visited America in 1851, and was at one time talked of for a baronetcy. He published *My Life as an Author* (1886). Of late his circumstances are said to have become reduced.

TURNER, SAMUEL HULBEART (1790-1861), theologian, was born at Philadelphia, Jan. 23, 1790. He graduated at the University of Pennsylvania in 1807 and was ordained to the Protestant Episcopal Church in 1811, becoming priest in 1814. He had charge of a church at Chestertown, Md., for five years, and in 1818 was elected professor of historic theology in the General Episcopal Seminary, New York. He remained in connection with this institution until his death, though he was transferred to the professorship of Biblical learning and interpretation of Scripture in 1821. He also held a professorship of Hebrew in Columbia College from 1831. He died Dec. 21, 1861. He translated Jahn's *Introduction to the Old Testament* and published notes on some books of the New Testament; *Biographical Notices of Distinguished Jewish Rabbis* (1847); *Scripture Prophecy* (1852); *Teachings of the Master* (1858); *Spiritual Things compared with Spiritual* (1850). He had also contributed to

leading theological reviews and other periodicals and left some manuscripts nearly ready for the press. His *Autobiography* was published in 1862.

TURNER, WILLIAM WADDEN (1810-1859), philologist, was born in London but emigrated to the United States in 1818, and learned the printer's trade. He became distinguished for his knowledge of ancient and modern languages. He was appointed librarian to the University of New York, and in 1842 instructor in Hebrew in Union Theological Seminary. In 1852 he removed to Washington to become librarian of the Patent Office, and died there Nov. 29, 1859. He had assisted in preparing Dr. Nordheimer's Hebrew text-books, and in translating Freund's *Latin-German Lexicon* as a basis of Prof. E. A. Andrews' *Latin Dictionary*. He devoted considerable attention to the languages of the American Indians and contributed to the linguistic publications of the Smithsonian Institution.

TURTLE. See TORTOISE.

TUSCARAWAS. See IROQUOIS.

TYLER, WILLIAM SEYMOUR, educator, was born at Hartford, Pa., Sept. 2, 1810. He graduated at Amherst College in 1830, and studied theology at Andover and was tutor at Amherst. In 1836 he was licensed to preach by the Third Presbytery of New York, but, being made professor of Latin and Greek at Amherst, he devoted himself to teaching. In 1859 he was ordained by a Congregational council, and thereafter preached occasionally in the college chapel and in various churches. He has published several scholarly text-books—*Tacitus' Germania and Agricola; Tacitus' Histories; Plato's Apology and Crito; Plutarch on the Delay of the Deity; Demosthenes De Corona; Demosthenes, Philippics and Olynthiæcs; Homer's Iliad*. He has published an essay on *Prayer for Colleges and a History of Amherst College* (1873), and *Theology of the Greek Poets* (1867).

TYLOR, EDWARD BURNETT, English anthropologist, was born at Camberwell, Oct. 2, 1832. He has devoted himself to the study of the races of men, their history, speech, and civilization. In 1871 he was chosen a fellow of the Royal Society, and in 1883 was appointed director of the University museum in Oxford, where he also delivers lectures. He is also president of the Anthropological Society. His publications are of the highest authority in his department of research. Among them are *Anahuac, or Mexico and the Mexicans* (1861); *Researches into the History of Mankind* (1865); *Primitive Culture* (2 vols., 1871); *Anthropology, an Introduction to the Study of Man and Civilization* (1881).

TYNDALL, JOHN, British physicist, was born at Leighlin-bridge, Ireland, in 1820. Although his parents were very poor he received a good elementary English and mathematical training, and at the age of 19 became a civil assistant in the division of the Ordnance survey which included his native village. In 1844 he was employed by a firm in Manchester and took part in railway engineering operations. In 1847 he became a teacher in Queenwood College in England, which was intended to give preliminary technical training to engineers and agriculturists. Here he became associated with the chemist Dr. Frankland, and entered on a series of physical investigations which have led to momentous results. The two friends, in furtherance of their work, in 1848 went to the University of Marburg, where they studied under R. W. Bunsen (*q. v.*). Afterwards Tyndall went to Berlin to work in the laboratory of Magnus. His researches had especial reference to magnetism and diamagnetism. His publications caused him to be chosen a fellow of the Royal Society, and in 1853 he was chosen to succeed Faraday as professor of natural philosophy in the Royal Institution at London. In 1856 he joined with Prof. Huxley in investigating the glaciers of Switzerland, and the results were given in a joint paper. Tyndall returned to Switzerland in 1857 and subsequent years, and after heroic exposure succeeded

in determining the winter motion of the Mer de Glace. In 1859 he began to investigate radiant heat, which led to his famous essay, *Heat Considered as a Mode of Motion* (1863), and his lecture *On Radiation* (1865). He had already received the degree of LL. D. from the University of Cambridge in 1855 and from Edinburgh in 1866; and Oxford joined in acknowledging his eminent merit by giving him the degree of D. C. L. in 1873. In the year 1872 he made a very successful lecturing tour in the United States, treating especially of light, heat, and sound. After defraying his expenses he gave the remainder of the proceeds, amounting to \$13,000, to a committee in aid of students who devote themselves to original research. In August, 1874, Prof. Tyndall presided at the annual meeting of the British Association held in Belfast. His opening address excited a great sensation by its support of materialism. He declared that he saw "in matter the promise and potency of all the forms of life." The address was published "with additions and a preface" (1874). He had already greatly shocked the conservative religious portion of the community by proposing to test the efficacy of prayer in behalf of a portion of the patients of a hospital. He was scientific adviser to the British Board of Trade and to the light-house authorities, but he resigned these duties in May, 1883. Prof. Tyndall has a cottage on the Alps and has given much time to the various natural phenomena to be observed in those lofty regions. Several of his books have reference to mountains. Besides his publications already mentioned may be noted *Sound* (4th ed., 1883); *Fragments of Science* (5th ed., 1876); *Forms of Water* (1872); *Floating Matter of the Air* (1881).

TYNG, STEPHEN HIGGINSON (1800-1885), clergyman, was born at Newburyport, Mass., March 1, 1800. He graduated at Harvard College in 1817; after spending two years in business pursuits he studied theology. He became rector of an Episcopal church at Georgetown, D. C., in 1821, and afterwards had charge of a church in Maryland until 1829. He then removed to Philadelphia, where he was rector successively of St. Paul's and Epiphany Churches until 1845. From that year until his retirement in 1878 he was rector of St. George's Protestant Episcopal Church in New York city. He died at Irvington, on the Hudson, Sept. 4, 1885. Dr. Tyng was an eloquent preacher and ready speaker. As a leader of the Low Church party he cultivated friendly relations with all Evangelical denominations. He was editor of the *Episcopal Recorder* in Philadelphia and of the *Protestant Churchman* in New York. He was an active promoter of Sunday-schools. Many of his sermons were gathered into book form. Besides these he published *Memoir of G. T. Bedell* (1835); *Forty Years' Experience in Sunday-Schools* (1860); *The Spencers* (1870); *The Office and Duty of a Christian Pastor* (1874). Under the title, *A Child of Prayer* (1866), he published a memorial of his son, Rev. Dudley A. Tyng, who had succeeded to his father's charge in Philadelphia, but was accidentally killed.

TYPHOID FEVER. See FEVER.

TYPOGRAPHY. For a full account of the invention and early history of the art of printing, and a complete exposition of that art, together with accurate definitions and descriptions of the phraseology of the composing-room and press-room, the reader is referred to the *ENCYCLOPEDIA BRITANNICA*. The work of the American printer and the tools and phraseology of his art are essentially similar to those of the English printer. Passing by these topics, this article will treat of the American printing-press, and especially of the rapid machines invented in recent years to meet the demands of the great daily newspapers. In all the successive achievements leading up to the marvellous results of the present time American inventors have held an honorable place. In

See Vol. XXIII, p. 681 (p. 723 Am. Rep.).

1827 the English firm of Cowper & Applegarth made important improvements on the old Koenig press, and built for the London *Times* a four-cylinder press which turned off 4000 or 5000 single impressions an hour. But when, a few years later, the American inventor, Richard Hoe, of New York, developed his so-called "lightning press," capable of printing 20,000 impressions an hour, the London *Times* was among the first to tear out its Applegarth presses and purchase the Hoe machines. Wondering crowds gazed at the first of the new Hoe machines when it was set up in the press-room of the Philadelphia *Public Ledger*. A few years later similar machines were in daily use by the New York *Tribune*, London *Times*, and Paris *La Patrie*. The eight- and ten-cylinder press certainly looked like a finality, but was soon superseded by the web perfecting press, which prints both sides at once from stereotype plates that can be duplicated to any extent desired, thus making it possible to have

gradually. Its evolution has been well described in *The Paper World*:

"The use of the continuous web of paper was suggested by Sir Rowland Hill as long ago as 1835; and in 1849 Jacob Worms, of Paris, hit upon the idea of curved stereotype plates secured to a rotating cylinder. Worms even built a press in which the printed sheets were separated from the web by a serrated blade and tension rollers, as in some perfecting presses now used, and made stereotype plates from a papier maché matrix, the material still considered the best. The press was patented in England in 1850, but met with no success, partly because it failed to deliver the sheets as fast as printed, and partly because the process of stereotyping, as then understood, involved too much delay. It was not until 1861 that the latter difficulty was overcome by Charles Crask, a New York engraver, whose improved stereotyping process was at once adopted by the New York *Tribune*. This made the

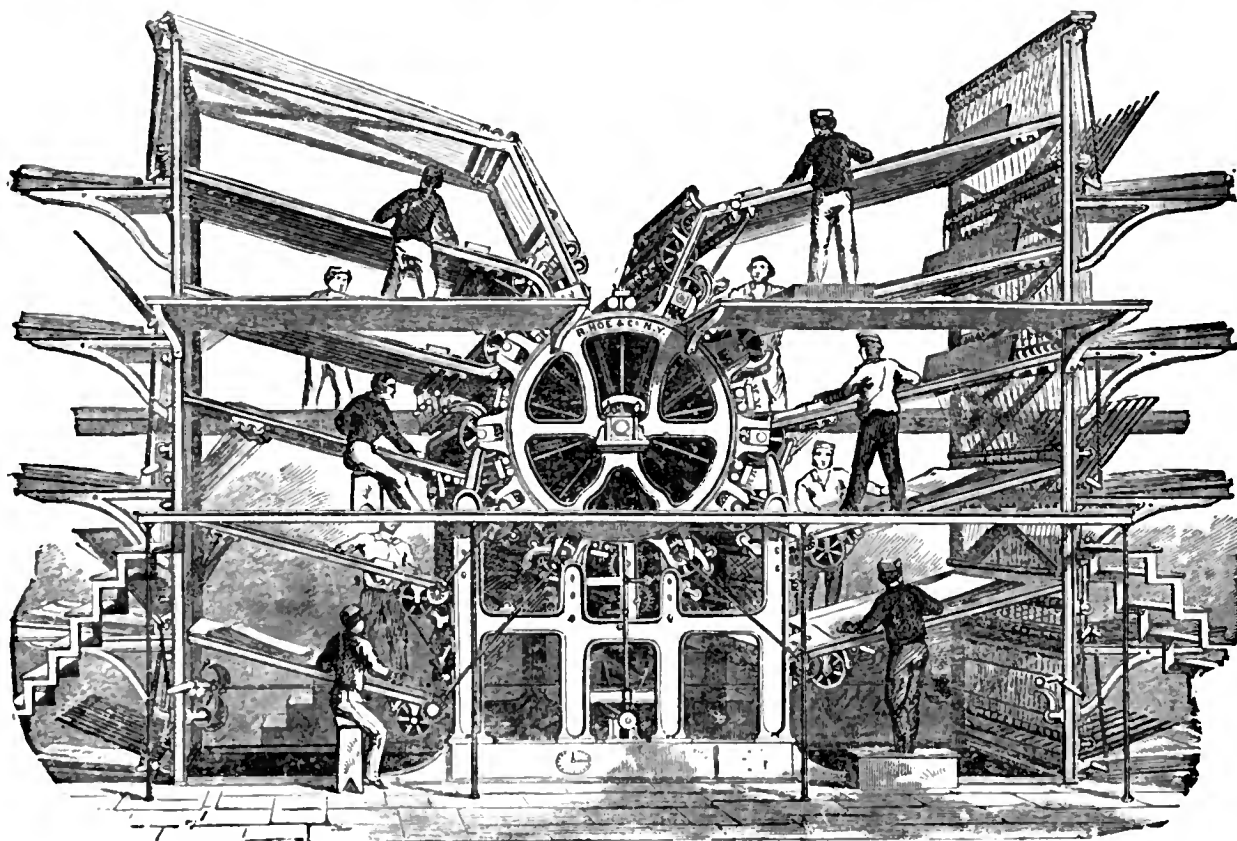

Old Style Ten-Cylinder Hoe Machine.

any number of presses at work simultaneously upon the same edition and on a continuous roll or web of paper. A glance at the accompanying cut, illustrating the old cylinder press at work, and a comparison with the illustration of the modern perfecting press, will give a fair idea of the vast improvement over the old form. The new invention practically quadrupled the productive capacity, while it required less than half the labor for running the machine. It naturally became the ideal press wherever great speed was necessary. The old cylinder presses are still found in many newspaper offices, and they give good results in the publication of weeklies or even dailies of comparatively small circulation; but wherever time is reckoned by seconds instead of by hours, there the rotary perfecting press is found, reeling out its perfect eight-page papers at the rate of 700 or more every minute.

The making of this marvellous machine came about

use of duplicate forms possible. The first web perfecting press capable of doing the work of a large morning newspaper was built by William Bullock, of Pittsburg, for the Cincinnati *Times* in 1861, and soon after a similar press was tried by the New York *Tribune*. Neither of these, however, accomplished all that was expected of it, and Mr. Bullock worked at his invention several years longer before he finally surmounted all obstacles and produced the improved press capable of printing 10,000 perfect newspapers per hour. The Walter press, which prints the New York *Times* and the London *Times*, is similar to Bullock's, with the addition of several improvements in matters of detail, which give it greater speed. (For illustration see Fig. 14 in article TYPOGRAPHY in the ENCYCLOPEDIA BRITANNICA.)

When these perfecting presses began to attain a speed of 8000 to 10,000 papers an hour, an unexpected limit was found in the impossibility of delivering be-

yond a certain rate from the fly. Richard Hoe and Stephen D. Tucker invented the contrivance that first obviated that difficulty in 1877—an accumulating cylinder on which six or eight sheets were laid one above another, and then delivered from the fly at one motion. This increased the practical working speed of the perfecting press to 18,000 per hour. Previous to that these gentlemen had designed a web perfecting press embodying all the improvements of Bullock, Walter, and other inventors, with many of their own. It was a lighter, more compact, and stronger machine, and rapidly superseded all others in the press-rooms of the great dailies. A folding attachment was then added, next a pasting and cutting attachment, and finally, in 1879, the most perfect printing machine up to that time made was first put into the press-room of the *St. Louis Republican*. Its production was 30,000 perfect eight-page papers per hour, printed, cut, pasted, and folded. That, like the ten-cylinder machine, seemed to be the end of printing press improvement; but the improvement has since continued.

The immense circulation attained in recent years by the great English and American dailies, together with the ever-present necessity of holding open their pages for "the latest news," has presented to the press-builder an intricate problem. The modern practice of expanding the four-page paper into the six- or eight-page sheet and the eight-page journal into one of ten or twelve pages on days when the pressure of the news or the demands of the advertiser warrant it has complicated that problem still further. The problem has been solved, however, by the invention of that marvel of mechanical ingenuity, the double supplement inseting press, by means of which a single or a double sheet supplement is readily turned out, cut, pasted, and folded into the body of the paper and that, too, at a rate of speed which permits the holding open of the news pages until the latest possible moment.

The development of journalistic enterprise has made ever-increasing demands upon the resources of mechanical ingenuity. The most rapid and the most reliable of the machines which have enabled it to do so are those of American make. They are found to-day in the press-rooms of the leading newspapers of England, Ireland, Scotland, and even in New Zealand and Australia, as well as in those of the greatest American dailies.

Probably the most productive printing-press ever built for making four- and six-page papers is that constructed in 1883 by Richard Hoe & Co., of New York and London, for a Philadelphia afternoon newspaper. It is claimed for this remarkable machine that it is capable of printing, pasting, counting, and folding ready for the carrier 96,000 four-page papers per hour, 48,000 six- or eight-page papers, or 24,000 ten-, twelve-, or sixteen-page papers, the four-, six-, and eight-page papers counted in lots of either 50 or 100, and the twelve- and sixteen-page papers in lots of 50, the papers being cut at the head, pasted, and folded half-page size. The ability to make the "inset" of an extra sheet, thereby making a six-page paper instead of one of four pages, whenever it seems desirable, is an advantage which every newspaper publisher appreciates. Aside from the loss of time involved in the process, the simple folding in of a single supplement sheet by hand, without pasting it, is often objectionable alike to the reader, the newsdealer, and the advertiser, and the extra sheet, if loose, is likely to be lost or discarded. It is such considerations as these, together with the considerable economy both of time and labor, that have placed the so-called perfecting, inseting, or double supplement machines far in advance of their foreign competitors in the race for speed and popular favor.

One of the best illustrations of the highest attainment in the art of press-building, up to the present time, is the Hoe quadruple web perfecting press which is now in daily use by the *New York World* and some

other metropolitan dailies. It prints four-page papers at a running speed of 90,000 per hour, folded carrier size; six- and eight-page papers at a speed of 45,000; and ten- and twelve-page papers at a speed of 24,000 per hour. As this machine is an excellent type of its class a somewhat detailed description of its mechanism is given.

A year was required for the building of this machine. It is composed of about 6500 parts and weighs about 53 tons. In each revolution of the plate cylinder it prints either four complete eight-page papers, or two complete sixteen-page papers with one eight-page sheet inserted in the other. In case of accident, either the main press or the supplement press can be run independently of the part which is crippled.

In the cut of the quadruple press the end of the press at the right is the supplement end, and the long cylinder near the top contains eight plates. The great roll of paper is near the floor to give steadiness to the machine and facility for handling. The paper roll of the main press, which prints the main sheet of the paper, is at the extreme left near the floor. The two presses are at right angles to each other, but are operated by the same power, and together, as in the case of the double presses, which are similarly arranged, but on a smaller scale. There is a passage-way between the main and supplement presses, and the main shaft for the supplement press is shown crossing the aisle near the floor. About two-thirds of that part of the machine to the right of this aisle is taken up by the supplement press, the remaining third being the apparatus for folding all the sheets which both presses can deliver.

The great roll of paper for the main press is about 6 ft. wide, weighs 1700 pounds, and requires two men, with block and tackle, to handle. The width of the margin of the printed page is regulated by a screw controlled by a hand wheel, shown at the head of the paper-roll spindle. This head is also equipped with a safety-brake, governed in a second by the smaller lever of the two inclined to the right. This safety-brake is used only in case of emergency; as, by means of an automatic paper-feed and paper-brake combined, the press is supplied with paper at the exact speed and tension required. This is done by an endless rubber belt, the outer end of which rests upon the top of the paper roll. The large main lever has a quadrant and latch like the reverse lever of a locomotive. This starts or stops the press by shifting the main driving belt, being assisted in stopping by a powerful friction-brake pressing upon the driving pulley on the main shaft.

To the left of this starting-lever are seen the ends of two cylinder shafts. The upper cylinder carries eight stereotype pages, which are supplied with ink from an ink fountain at the highest point of the left-hand end of the machine, as it appears in the cut. The ink is distributed by composition rollers having both a revolving and shifting motion so as to distribute the ink that is fed to the distributing rollers by the adjustable fountain. By thumb screws placed closely together along the entire length of the ink fountain, the flow of ink to any portion of the rollers can be regulated to a nicety, thus enabling the pressman to put more or less "color" upon any column in the paper. The lower cylinder is the impression cylinder, carefully jacketed and so adjusted in position as to bring the paper, which travels between it and the inked plate cylinder, up against the latter, giving it a full and perfect impression.

The endless web is thus printed upon one side, and it then passes between the large second-impression cylinder (shown at the right of the starting-lever) and the second plate cylinder (shown in line with the first). This gives upon the other side of the web the impression of the opposite pages. The paper web runs along the line of the top of the frame and over the aisle and

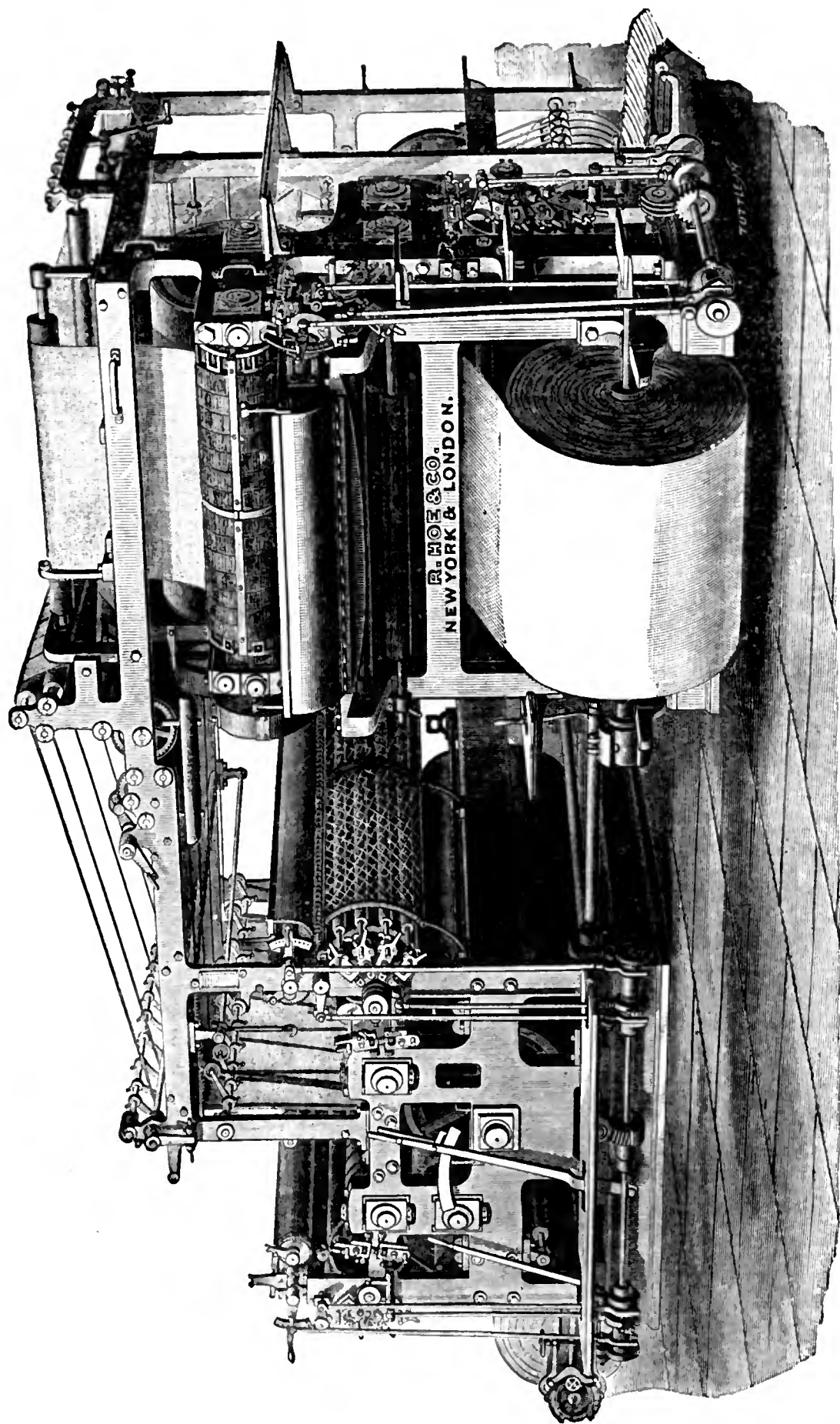

MODERN DOUBLE SUPPLEMENT STEREOTYPE FETTING MACHINE.

turning-bar placed diagonally across the frame, from which it passes down into the supplement press at right angles to its former course. The operation of the supplement press (on the right in the engraving) is practically the same as that of the main press. In case of the quadruple press each division of the machine has the same producing power as regards size and number of sheets.

After the web from the main press is carried over the angle-bar, which changes its direction to one at right angles to its previous course, it passes around a roller, which returns it upon its course in the direct path with the sheet coming from the supplement press. Thereafter the double web passes to the head of the "formers," where a rotary knife separates the two sheets lengthwise of the web. Each part passes down over the "former," which is an inclined triangular form, placed point downwards between two rollers, which completes the operation of making a central lengthwise fold in the double half-web.

The folding triangle is inclined about 50° to the horizontal, and its shape is such that as the sheets glide smoothly but rapidly down its outer surface the outer edges of the web are curved down and inward until upon leaving the triangle they gradually meet between a pair of horizontal rollers. The width of the combined web is now only that of a single page, but it still continues a continuous web. A pair of folding- and cutting-cylinders carries a double set of knives, which separate each eight-page or ten-page sheet, as the case may be, from the moving web, while folding-blades on the opposite cylinders crease the paper across the middle of the page and thrust it between the small rolls, which give it the final fold and hurry it to the delivery.

Before a paper is completely separated from the web small pins dart out from the folding-cylinder close to the blade and catch the web, so as to hold it until after the length of a page has been completely severed. This is accomplished by the paper being grasped by a series of tapes running faster than its previous speed, which, breaking the points of attachment which were left by the cutting-blades, rush the papers to a collecting-cylinder. The pasting is done by the web running over the edge of a pasting-wheel, which revolves in a trough of paste, and leaves a track of paste down the centre of one of the webs.

The papers are dropped, folded half-page size, upon a set of leather belts, which carry them out from the folding-machine, and automatically count them in piles of 50 as they go. The folder can be run in connection with either one of the printing-machines or with both. This machine occupies but little space and requires only three men and two boys to operate it. The various supplement presses work almost exactly as the quadruple press does, only the size of the supplement sheet is smaller. The quadruple press might be called a double double-perfecting press. The other supplement presses from which the quadruple has developed are really triple presses.

By means of these compound presses, capable of running two webs of paper through them, it is possible, by varying the cutting up of the webs, and by using one-half of the press or both, to make two-, four-, six-, eight-, ten-, twelve-, or sixteen-page papers. These presses accomplish their work with much less liability to stoppage from choking or clogging of the printed sheets while passing through the folder than their predecessors did. The great power and production of these presses are due to their simplicity of construction. While a single machine accomplishes its work with a considerable detail of complicated mechanism, such as the switch, the collecting-cylinder, a perfect network of tapes, etc., the new double stereotype inseting machines dispense with nearly all these, except the tapes, which are reduced in number and extent.

As often as some new invention or some new application of an old one has eclipsed all former achieve-

ments, so often has an applauding public believed that the acme of perfection in the building of speedy presses has been reached; yet the ideal is still before us. It may well be that the machine just described will in time share the fate of its predecessors and give place to a greater one, but up to the present time it may be said to mark the highest attainment of the art.

COLOR-PRINTING.

Progress in the art of color-printing, though less remarkable than that in the manufacture of newspaper-presses, deserves mention. Probably the greatest recent advance in this branch of the art is that marked by a machine only lately introduced, the inventor and patentee of which is a Philadelphian. Though this new color-press has not yet come into general use, there can be little doubt that it has proved the possibility of printing by means of a perfecting-press one sheet of paper on both sides and in several colors simultaneously, thus enabling the printer to produce an illustrated paper, book, or pamphlet in illuminated colors. Incredible as this may seem, it is claimed that the complete set-off system contrived in this machine will enable a skilled printer to accomplish this result. A recent issue of *Paper and Press* contains the following description of this interesting and important invention:

"Colors are now known to some ink-manufacturers that will work on each other while wet and give good results. This has been a constant study of the inventor for over seventeen years, and he is said to have proved that many designs may be effectively printed at one operation or passage of a sheet through a machine, thus expediting work, and often with greater advantages than handling the sheet each time separately for each color.

"Another form of this machine will enable one to print cartoons or pictures from zincographic surfaces in outline, and then fill in the picture with rich, transparent colors from relief-plates, thereby dispensing largely with very troublesome wetting of the color parts of the picture. Thus it may be converted into a semi-lithographic machine, and produce chromo-zincotypes, for illustrations suitable for a children's pictorial or serial. The style may be also adapted to print both sides at one time, where a large edition would demand it.

"The machines can be constructed to do a great range of work—from printing a series of labels in colors to printing a plain surface on one side; or the same press can be used to print a book with great rapidity on both sides at once.

"This system is based on the principle of two cylinders of unyielding construction running in harmony with each other. The plate-cylinder is twice the diameter of the impression-cylinder, and thus three points are gained; the smallest possible line of contact in impression, giving strength and speed; the largest diameter, so that the plates will not need much curvature; and a portion of the plate-cylinder to act as a table or distribution-surface for the ink. Each color or side is isolated from the other, thereby preventing a discoloration by the ink flying while in rapid distribution.

"Every color has a separate pair of cylinders. The sheet is carried rapidly between each pair of cylinders by an elastic gear-wheel, or positive-motion metallic band, to which is attached a series of grippers, and is held fast in proper position until it has received any number of impressions on one or both sides. When the sheet is perfected it is then carried by the same grippers to a point of delivery, and may be delivered on a table or passed through any ordinary folding-machine. Thus, it would be printed, if necessary, on both sides in colors, and folded ready for delivery. The speed of a machine may be made to suit any special want, because there are no reciprocating- or eccentric-motions to give impressions. All the parts

are rotary, and there are no difficult mechanical problems to be overcome."

TYPE-CLASSIFICATION.

American Point System.—English printers still suffer from the same trouble that proved a serious annoyance in this country previous to the universal adoption by American type-founders of a uniform gauge of type measurement known as the "American Point System." Type made by different founders varied considerably in the size of its body, though designated by the same name. Printers upon reinforcing an old font of minion, for instance, with a new outfit of minion made by a different founder, sometimes discovered that the difference in size between the two fonts was so considerable that the type would not "justify," and consequently the two fonts could not be mingled. This difficulty has been obviated by the adoption of the "Point System." This system lays down the cardinal dictum that the dimension of pica body shall be 12 "points," and that 83 pica bodies—996 points—must be exactly equivalent to 35 centimetres. Here we have a unit of measurement (the point) which is based upon the French metric system—an invariable gauge. Having agreed upon this sound basis the American type-founders adopted the following uniform measurements for the bodies of type in common use:

Name under Point System.	Name under Old System.
3-point body	<i>Excelsior.</i>
3½ " "	Brilliant.
4 " "	<i>Semi-Brevier</i>
4½ " "	Diamond.
5 " "	Pearl.
5½ " "	Agate.
6 " "	<i>Nonpareil.</i>
7 " "	Minion.
8 " "	<i>Brevier.</i>
9 " "	{ Bourgeois.
	{ <i>3-line Excelsior.</i>
10 " "	Long Primer.
11 " "	Small Pica.
12 " "	<i>Pica.</i>
	{ 2-line Minion.
14 " "	{ English.
16 " "	{ 2-line <i>Brevier.</i>
18 " "	{ Great Primer.
	{ <i>3-line Nonpareil.</i>
20 " "	{ 2-line Long Primer.
	{ Paragon.
22 " "	2 line Small Pica.
24 " "	<i>2-line Pica.</i>
28 " "	2-line English.
30 " "	<i>5-line Nonpareil.</i>
32 " "	{ 3-line Small Pica.
	{ <i>4-line Brevier.</i>
36 " "	{ 2-line Great Primer.
	{ <i>3-line Pica.</i>
40 " "	Double Paragon.
42 " "	<i>7-line Nonpareil.</i>
44 " "	{ 4-line Small Pica.
	{ Canon.
48 " "	<i>4-line Pica.</i>
54 " "	{ 5-line Small Pica.
	{ <i>9-line Nonpareil.</i>
60 " "	<i>5-line Pica.</i>
72 " "	<i>6-line Pica.</i>

Height to paper, 2½ centimeters.

The bodies indicated in italics in the above table are those whose dimensions, as made by the most extensive American type-founders prior to the adoption of the new system, were the same as they now are under the point system. The old excelsior, brevier, or pica, for instance, as made by the best founders before the innovation, is identical with that now adopted, and mixed fonts of the new and old would justify readily. But the new brilliant, diamond, or pearl would not work with the old bodies, each being a fraction of a point larger or smaller than was the prevailing brilliant, diamond, or pearl of the old *régime*.

The pica body adopted as the standard under the point system was that made by the Johnson type-foundry, of Philadelphia, the oldest of its kind in the country, being established in 1794.

MUSIC-TYPOGRAPHY.

Music-typography is the art of representing a musical composition by the combination of movable types, on which are the staff-lines and the various musical signs and characters. The art, though an old one, has only recently been developed to a high state of perfection. As early as 1482 Oct. Scotus, of Venice, printed music from type at two separate impressions, the first printing the staff only and the second the notes upon it. Erhard Oeglin, of Augsburg, in 1507 was the first to succeed in printing both the staff-lines and the music at a single impression. He may be regarded, therefore, as the pioneer of the present system, though his productions were naturally crude as compared with the work of the present time. The early form of printed notes was square: then a diamond- or lozenge-shaped note-head was substituted, and in the latter part of the seventeenth century the round-shaped note now in common use was adopted. The first American who employed movable type for the printing of music was Christopher Sower, of Germantown, Pa., who, in 1753, printed and published in the German language a *New, Enlarged, and Complete Song-Book, wherein are contained as well the Psalms of David*. Sower cast his own type, and his musical typography was legible, but still crude and far from beautiful. As the art of stereotyping did not come into general use until about the year 1810, all music-printing prior to that time was done directly from the type. The wear and tear of press-work soon battered the type so seriously as to impair or ruin it, and the process of musical typography was an expensive one. At present, however, the type itself is used only as the basis from which are cast, either electrotypes or stereotype plates. The printing is done from these plates, and the type, not coming in contact with the press at all, with careful usage on the part of the compositor and electrotyper, may be made to serve for a long time without injury.

John M. Armstrong, who was born in New York, in 1833, and died Jan. 25, 1878, probably did more than any other American to develop the art of music-typography to its present state of perfection. He made this task the study of a lifetime, and in many ways improved greatly upon the German fonts, which up to his time had been the best available. To his efforts was due the introduction of many new logotypes, brass lines, stems, and straight ties of various lengths, all of which are recognized as among the indispensable features of the present system.

A page of music-typography is made up of an indefinite number of small pieces, so united by the deft hands of the compositor as to represent continuous lines and characters. If the type is in good condition and the work is done skilfully there are no breaks visible between these many small component parts, the junctures being so perfect as to defy detection. For instance, the group of notes combined in Fig. 1 is made up of 29 pieces, as shown in Fig. 2. To make the



Fig. 1.

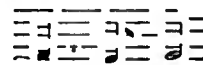

Fig. 2.

various and almost infinite combinations required in the representation of an intricate piece of music upwards of 500 separate typographical characters are used by the musical-compositor. Figs. 3, 4, and 5 represent the upper-, lower-, and side-cases, comprising a full font of music-type, with each character located in the box or compartment in which it belongs. In the upper-case are shown in the left-hand side the ties used for connecting the stems of the notes. These are

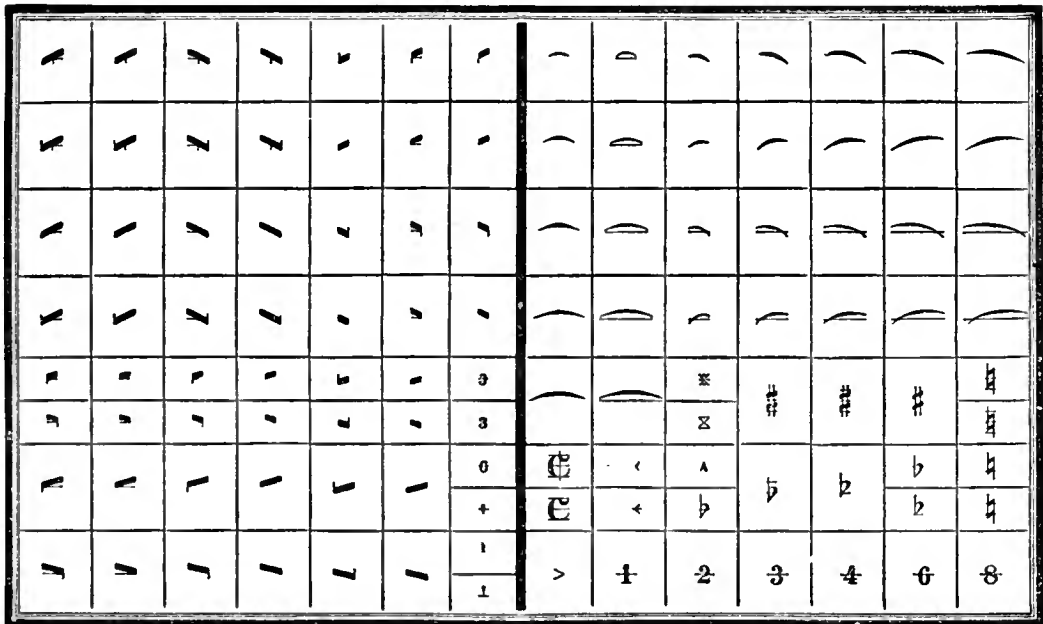

Fig. 3.

necessarily of various lengths, and produced at various angles to the staff-lines, in order to connect properly notes or different portions of the musical staff; in the right-hand section of the case is a similar assortment of slurs, also adjusted at varying angles to the staff-lines, for the same reason; there, too, are the accidentals (sharps, flats, etc.), some of them on the staff-lines and others on the spaces.

In the lower-case (Fig. 4) are the several notes and rests—some on the lines and others on the spaces—note-stems, bass and treble-clefs, pauses, the quadrates, and sections of the staff-lines in various lengths.

In the middle compartment of the side case (Fig. 5) are the characters known to the musician as grace-notes, the diminutive accidentals, etc., and the other sections of the same case contain the numerals, crescendo and diminuendo characters, and other symbols which the musician will recognize readily.

There are in common use five styles of music type, the "bodies" of which are of different sizes. There are also various fonts of the same sized "body," but printing the note-heads larger or smaller. The prevailing styles are shown in Fig. 6. The smallest type, beginning at the top of the figure, is known as "Exceelsior 2," and the others, in the order in which they are shown in the plate, are "Exceelsior Music," "Diamond," "Diamond 3," "Diamond 2," "Agate 3," and "Nonpareil 3."

Character Note Systems.—Various typographical devices have been introduced from time to time with the common object of simplifying the reading of musical compositions. None of these has as yet been adopted so extensively as to supersede the common system, though the device known as the Tonic Sol-Fa system is meeting with considerable favor, especially in England. The Tonic Sol-Fa system dispenses en-

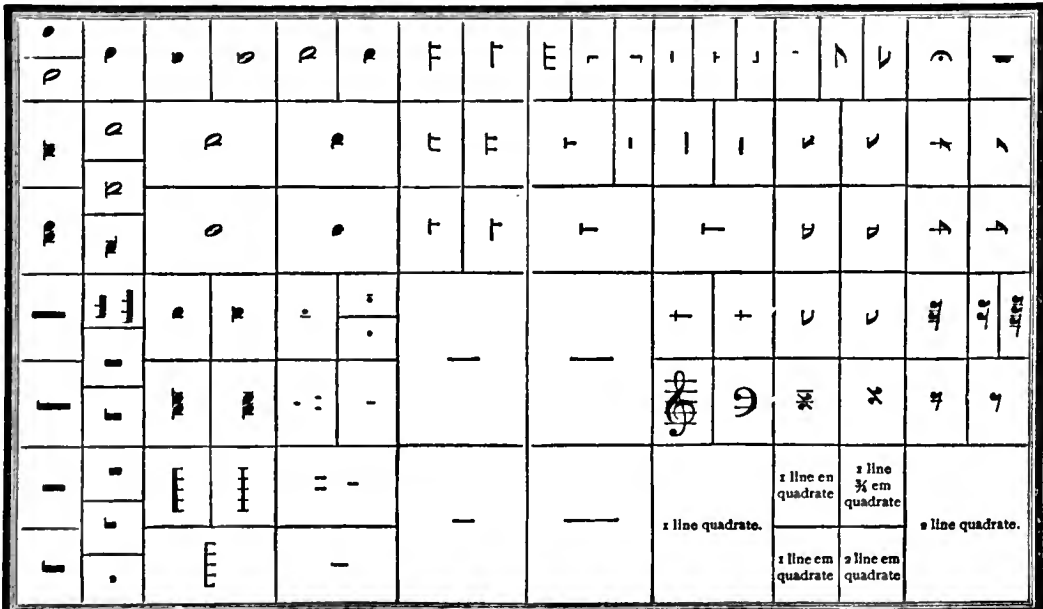

Fig. 4.

<i>f</i>	<i>f</i>	<i>f</i>	<i>f</i>	<i>f</i>	<i>f</i>	*	<i>f</i>	<i>f</i>	<i>f</i>	<i>f</i>	<i>f</i>	<i>f</i>	<i>f</i>	<i>f</i>	<i>f</i>	<i>f</i>	<i>f</i>	<i>f</i>	<i>f</i>
<i>f</i>	<i>f</i>	<i>f</i>	<i>f</i>	<i>f</i>	<i>f</i>	Ped.	<i>f</i>	<i>f</i>	<i>f</i>	<i>f</i>	<i>f</i>	<i>f</i>	<i>f</i>	<i>f</i>	<i>f</i>	<i>f</i>	<i>f</i>	<i>f</i>	<i>f</i>
<i>f</i>	<i>f</i>	<i>f</i>	<i>f</i>	<i>f</i>	<i>f</i>	SS	<i>f</i>	<i>f</i>	<i>f</i>	<i>f</i>	<i>f</i>	<i>f</i>	<i>f</i>	<i>f</i>	<i>f</i>	<i>f</i>	<i>f</i>	<i>f</i>	<i>f</i>
<i>f</i>	<i>f</i>	<i>f</i>	<i>f</i>	<i>f</i>	<i>f</i>	<i>f</i>	<i>f</i>	<i>f</i>	<i>f</i>	<i>f</i>	<i>f</i>	<i>f</i>	<i>f</i>	<i>f</i>	<i>f</i>	<i>f</i>	<i>f</i>	<i>f</i>	<i>f</i>
<i>f</i>	<i>f</i>	<i>f</i>	<i>f</i>	<i>f</i>	<i>f</i>	<i>f</i>	<i>f</i>	<i>f</i>	<i>f</i>	<i>f</i>	<i>f</i>	<i>f</i>	<i>f</i>	<i>f</i>	<i>f</i>	<i>f</i>	<i>f</i>	<i>f</i>	<i>f</i>
<i>f</i>	<i>f</i>	<i>f</i>	<i>f</i>	<i>f</i>	<i>f</i>	<i>f</i>	<i>f</i>	<i>f</i>	<i>f</i>	<i>f</i>	<i>f</i>	<i>f</i>	<i>f</i>	<i>f</i>	<i>f</i>	<i>f</i>	<i>f</i>	<i>f</i>	<i>f</i>
<i>f</i>	<i>f</i>	<i>f</i>	<i>f</i>	<i>f</i>	<i>f</i>	<i>f</i>	<i>f</i>	<i>f</i>	<i>f</i>	<i>f</i>	<i>f</i>	<i>f</i>	<i>f</i>	<i>f</i>	<i>f</i>	<i>f</i>	<i>f</i>	<i>f</i>	<i>f</i>

Fig. 5.

tirely with the common staff-lines of the musical scale, and also with the note characters. The seven tones (*do re mi fa sol la si*) are indicated by the initial letters, *d, r, m, f, s, l,* and *t*, printed in bold, plain-faced type. An upper tone is distinguished from the one an octave below it by means of an accent mark printed above the initial letter which indicates the note. By combinations of these initial letters any musical chord may be represented readily enough, while the time, the value of the several notes, the rests, pauses, slurs, etc., are represented by similar typographical expedients, which are not difficult to master.

Another idea which has been developed in various forms is that of indicating the tone by the peculiar shape of the note-head, the theory being that the shape of the note-head, together with its distinctive position on the staff, makes a double appeal to the eye of the musician and renders the note more readily identified. One of the most ingenious of these systems is that introduced by Jesse B. Aikin, an American, who contrived a different shaped note-head for each of the seven tones, round, semi-circular, rectangular, diamond-shaped, and triangular forms, all being employed in his method. In all of these devices the shape of the note-head is the main distinguishing feature, the staff lines still being retained generally (though the idea theoretically permits of their abandonment), and the values of the several notes being represented by note-stems, dots, etc., as in the prevailing system.

In Aikin's system the seven characters employed are as follows:

▲ do ◆ re ◊ mi ◻ fa ◼ sol ◽ la ◾ si

The smallest type, beginning at the top of the figure, is known as "Excelsior 2," and the others, in the order in which they are shown in the plate, are "Excelsior Music," "Diamond," "Diamond 3," "Diamond 2," "Agate 3," and "Nonpareil 3."

Fig. 6.

(H. P.)

U.

UMBRELLA TREE. The tree known under this title is one of the several American species of magnolias, its specific designation being *magnolia umbrellata*. It is a small tree, rarely more than 36 ft. high, and with a trunk less than a foot in diameter. Its range is from south-east Pennsylvania along the Alleghenies to central Alabama, and westward through Kentucky and Tennessee to north-east Mississippi, it also oc-

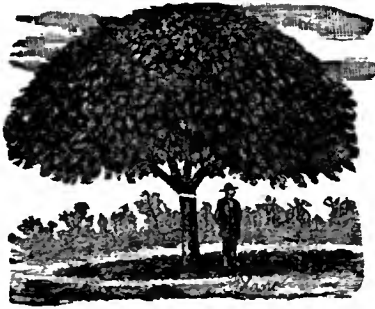

Umbrella Tree.

curing in central and south-west Arkansas. It is most common on the western slopes of the southern Alleghenies, where it frequents rich, shady hillsides. Like all the magnolias it is a handsome tree, bearing very large, white, highly-scented flowers, and a rose-colored fruit. It gets its name from the fact of the leaves being crowded on the summit of the flowering branch in an umbrella-like circle.

UNION COLLEGE. This institution of learning at Schenectady, N. Y., was founded in 1795 by the Regents of the University of the State of New York, in response to a petition of 127 citizens of the State. Several earlier but unsuccessful efforts had been made to accomplish the same end.

The prime movers in all later efforts were the proprietors of the Schenectady Academy, originally established in 1785 under the patronage of the Reformed Dutch Church. In 1792 and again in 1794 the request of its managers for a charter under the title "The College of Schenectady," was denied, but finally a plan was framed designed to obviate the objections made to former applications, and coupled with an offer of the immediate use of the academy building. This scheme proposed the name "Union College" and provided guarantees for the independence of the institution from all sectarian bias. The charter was granted on Feb. 25, 1795, over the signatures of George Clinton, governor and chancellor, and De Witt Clinton, secretary. The charter granted all the rights and privileges enjoyed by Columbia College, fixed the number of trustees as twenty-four, gave them power of perpetual succession, of appointing officers of instruction and government, of making ordinances for government, and of conferring such degrees "as are usually granted by any or either of the universities of England." Subsequent amendments reduced the number of trustees to twenty-one, and admitted certain officers of the State to *ex-officio* membership. In 1873, by act of the Legislature, an additional university charter was obtained by which permission was granted several existing institutions to unite with Union College in the formation of Union University.

The new institution was housed at once in the two-story brick academy building, 50 by 30 feet, and remained in these humble quarters until a new and commodious structure of stone, three stories and basement, 150 by 60 feet, costing about \$56,000, was completed in 1804. Since 1854 this building has

been the main edifice of the public school system of the city. The only evidence of its former collegiate use remains in the name of the neighboring "College street."

During the first nine years of its history, 1795 to 1804, the college had three presidents, Rev. John Blair Smith, D. D., Presbyterian, Rev. Jonathan Edwards, D. D., Presbyterian, and Rev. Jonathan Maxey, D. D., Baptist. In 1804 began the presidency of the distinguished Eliphalet Nott, D. D., LL. D. At the time of his election to the presidency he was a Presbyterian clergyman in the city of Albany, a member of the board of trustees of Union College, and known to the general public chiefly as the author of the funeral oration over Alexander Hamilton. Dr. Nott retired from the official management of the college in 1861, after nearly sixty years of continuous service, but he really continued to direct the affairs of the institution until his death in 1866. He was succeeded by the profound metaphysician, Rev. Laurens P. Hickok, D. D., LL. D. Upon the retirement of Dr. Hickok in 1868, the nominal presidency was conferred upon the Hon. Ira Harris, LL. D., of Albany, then president of the board of trustees. The actual management of the college, however, devolved upon Prof. Isaac W. Jackson, LL. D., senior member of the faculty. Subsequent presidents were Rev. Charles A. Aiken, D. D., Ph. D., a graduate of Dartmouth, and Rev. Eliphalet Nott Potter, D. D., LL. D., a grandson of Dr. Nott and an alumnus of Union, who succeeded Dr. Aiken in 1871. During the administration of Dr. Potter, 1871 to 1884, the buildings were materially improved, their number increased, the classes enlarged, and the funds of the college strengthened. Upon the retirement of Dr. Potter in 1884 to take the presidency of Hobart College occurred an interregnum of four years, during which affairs were directed by Hon. Judson S. Landon, LL. D., as president *ad interim*.

In June, 1888, Harrison Edwin Webster, LL. D., an alumnus and former professor of the college, was called to the vacant presidency. Among eminent instructors connected with the college at various times during its history may be mentioned Rt. Rev. Alonzo Potter, D. D., LL. D., who subsequently became Bishop of Pennsylvania; Rev. Francis Wayland, D. D., LL. D., subsequently President of Brown University; Tayler Lewis, LL. D., the eminent oriental scholar and author, one of the foremost Greek scholars in the United States; William Mitchell Gillespie, LL. D., founder of the school of civil engineering at Union; Isaac W. Jackson, LL. D., author of various mathematical works; Jonathan Pearson, A. M., distinguished for antiquarian researches, and John Foster, LL. D.

The grounds of Union College comprise about 130 acres, within city limits but on the north-east verge. They are greatly diversified, and command a wide and charming view. They include also a famous garden of several acres, the memorial of Dr. Jackson, whose name it bears and to whose devotion its loveliness is a perpetual witness. The present buildings occupy a broad level terrace nearly half a mile in length. The main structures, North and South Colleges, respectively, are each in the shape of an L, and include between their long arms a campus 600 feet in breadth. The front line of buildings, 200 feet long in each college, is four stories in height, and is flanked by the residence of a professor, one at each extremity and one at each angle, making four in all. The wings, somewhat lower, and called the colonnades, extend at right angles 300 feet to the rear and include the campus between their parallel

sides. The material is brick, grouted gray, and diversified by pilasters of white. The front edifice of each college is subdivided into three sections, each containing 16 rooms and giving a total dormitory accommodation of about 200. The engineering-rooms, the chemical and physical laboratories, the armory, the natural history museum, the chapel, and the recitation-rooms of the departments of Greek, modern languages, engineering, chemistry, physics, natural history, and military science are contained in this set of buildings.

At the back of the campus, midway between the colleges, stands a sixteen-sided structure of stone, 84 feet in diameter, and surmounted by a dome rising to a height of 120 feet above the ground-floor. The exterior ornamentation is white sand-stone and Scotch granite. The interior has a mosaic pavement of Salop tile, the walls are rivetted with polished marble, the galleries are of corrugated iron, and light is admitted through stained glass. This costly structure was erected by Dr. Potter at the cost chiefly of the Hon. Clarkson N. Potter, and Mr. Howard Potter, as a memorial of Dr. Nott. At a short distance to the rear is a semi-circular structure of pressed brick. The central part, two stories in height, and fire-proof, contains the library.

The wings hold the recitation-rooms of the departments of mathematics, English, Latin, philosophy, and ethics. The central portion is styled "The Washburne Memorial Library Hall," the rest of the structure "The Thomas Henry Powers Memorial Hall." The gymnasium is a detached structure of brick in the rear of South College. In addition to the four residences already mentioned are the following: the dwelling, formerly Dr. Nott's, now occupied by the president; the house built by Dr. Potter for his use; a handsome Swiss cottage erected by Hon. Samuel T. Benedict for the use of Dr. Jackson and wife, and in virtue of this consideration held by himself under a life-lease, and two other residences. The remaining buildings are the photographic rooms, bath-houses, stables, and cottages occupied by college servants.

The departments of law, medicine, pharmacy, and the observatory which with the college constitute the university are situated in Albany.

The library contains about 30,000 volumes. Its special features are the Gillespie collection of engineering and scientific works, the Patterson collection of mathematical works, and very complete sets of the great literary reviews. Connected with it is a reading-room supplied with the leading current magazines and reviews.

Under the title of apparatus and collections may be mentioned the following: 1. In physics a costly set of apparatus for illustration and experiment in electricity, magnetism, light, heat, acoustics, pneumatics, etc. 2. In natural history, the Wheatley collection of shells and minerals, the gift of the Hon. E. C. Delavan, valued at over \$80,000. The collection of marine invertebrate faunas, made by President Webster and his assistants during his incumbency of the professorship of natural history, representing the results of fifteen years of special research along the Atlantic coast of North America and the west shore of the Gulf of Mexico, and of exchange of duplicates for specimens from nearly every part of the world. The fine collection of North American birds, gathered and mounted by James E. Benedict, A. M., some time assistant to the department of natural history. 3. In engineering, instruments of every class, representing the entire development of practical engineering. The Olivier models, 50 in number, representing the most important and complicated surfaces of descriptive geometry, invented by Prof. Theodore Olivier, of the Paris "Conservatoire des Arts et Metiers." Of the three existing sets, Union College has the fullest and the original. Bardin's (Paris) plaster models of intersections, Schroeder's (Darmstadt) models, stone-cutting

models from "L'École Polytechnique," architectural models from "L'École des Beaux Arts," bridge models, including Doyne's dynamometer bridge model, etc., and over 50,000 plates of engineering and architectural structures.

The courses of study offered at Union are four: the classical, the scientific, the Latin scientific, and the engineering. The degrees conferred in the course are A. B., B. S., and C. E. The faculty includes the president, eleven professors, a professor emeritus, a tutor, and a lecturer. There are several grades of scholarships, granting credits that range from \$50 to \$300 per year. Various commencement prizes are offered for excellency in oratory, essays, debate, and general standing.

The list of commencement prizes embraces:

Oratory,	{ Blatchford Medals,	two.	Total value \$70.
	{ Junior and Sophomore,	four.	" " 50.
Extemporaneous	{		
Debate,	{ Veeder,	one.	" " 50.
	{ Ingham,	one.	" " 70.
Essays,	{ Clarke,	two.	" " 25.
	{ Allen,	three.	" " 60.
Conduct	{		
and	{ Warner Cup,	one.	" " 50.
Standing,	{		
	{ Military,	three.	" " 75.

Honors consist of assignment to place among the ten commencement orators, the valedictory, special mention for high standing and extra work.

College Societies.—The old Adelpheic and Philomathean Debating Societies still exist, but their function has in large measure been transferred to the secret societies. The students publish the *Concordianist* monthly during college year, and the *Garnet* annually. (J. R. T.)

UNITED LABOR PARTY is a political organization which grew out of the Central Labor Union in New York city. This union was established in the winter of 1881-82, and its origin is traced to a meeting held for the purpose of expressing the sympathy of workmen in New York city with the poor of Ireland. In the autumn of 1882 the Union nominated candidates for Congress, the State Assembly, and the city board of aldermen. But the Labor vote in the election was trifling until Henry George (q. v.) had commenced an agitation for the nationalization of land. In July, 1886, the Union appointed a committee to prepare a plan of political action. After several conferences a city convention was held Sept. 23, at which 176 labor organizations were represented. The platform adopted practically affirmed George's doctrines, and the convention nominated him for mayor with little opposition. The candidate of the united Democracy was Abram S. Hewitt, and the Republican candidate, Theodore Roosevelt. Mr. George made over 100 speeches during the campaign, and by his energetic action roused both friends and foes to unwonted efforts. Before the nomination he had received the pledges of 34,000 voters. The election gave Hewitt 90,552; George, 68,110; and Roosevelt, 60,435. As the strength of the Greenback-Labor party (see GREENBACK PARTY) had been in the country districts, this result seemed to show that a similar element existed in the large cities. The problem for their leaders was how to unite these elements in an effective organization. In New Haven the Labor party obtained about 1000 votes in November, 1886, but the movement in Boston failed as an element in the campaign. In New York city those who supported George determined to call themselves the "United Labor Party," and they prepared a constitution with the following preamble: "We, the representatives of the United Labor party of the city and county of New York, believing that governmental corruptions and injustices spring from neglect of the self-evident truth that all men are created equal; that the advantages arising from social

growth and improvement belong of right to the society at large, and that the true purpose of government is the maintenance of that sacred right of property which secures to every man the fruits of his own labor; demand that in the drawing of grand-jurors there shall be no distinction of class; that the property qualification for trial jurors shall be abolished; that equal pay for equal work should in public employment be accorded without distinction of sex; that police interference with peaceful assemblages should cease; that our elective methods should be reformed; that the people of New York should have full control of their own local affairs: that the procedure of our courts should be simplified; that the laws for the safety and sanitary inspection of buildings should be enforced; that all laws which bear unjustly on labor should be abolished; that in public work all labor should be directly employed; that all taxes on buildings and improvements should be abolished; that all taxes should be levied on land values which arise from and are due solely to increase of population; that existing means of transit should no longer be left in the hands of corporations, but should by lawful process be assumed by the city and operated for the public benefit."

In Chicago a branch of the party was established which required each member to take a pledge to support its candidates.

The first regular convention of the United Labor party met in New York in January, 1887. In the New York Legislature of 1887 a law was passed, with little opposition, allowing this new-born party to have two inspectors at every polling-place in the city of New York, thus giving it the same privileges enjoyed by the older political parties. It had also the advantage of an organization well provided with workers who had become alienated from the larger Democratic organizations.

Yet from this climax of its political power the United Labor party rapidly dwindled in numbers. One of the chief supporters of George was Dr. Edward McGlynn, who was suspended from his functions as a Roman Catholic priest on account of his pronounced opinions in favor of the land-nationalization theories. Many of the sympathizers with the movement could not follow it as long as Dr. McGlynn was under a ban. At its State Convention, held in Syracuse in August, 1887, Socialists were excluded from the party. Henry George was nominated for Secretary of State, and along with him a complete ticket for State officers. The platform took more advanced ground in regard to George's theories, and also resolved in favor of many measures of particular importance to laboring men, as to the hours of work, free schools, etc. In the election of November, 1887, George secured 70,055 votes in the State of New York, his vote in New York city having fallen to 37,477; but in Kings co. (Brooklyn) he had 15,635, or nearly 1000 more than his party obtained in 1886. In October, 1888, the party nominated Mr. James J. Coogan for mayor of New York city, but in the bewildering whirl of the national Presidential election he obtained only 9809 votes. Thus within two years the United Labor party dropped from the surprising vote of 68,000 to comparative insignificance. The indications are that the party has no real bond of coherence, and cannot maintain its existence as a factor in politics. But its sudden rise and its fall no less sudden form a peculiar chapter in the history of American politics. (See SOCIALISM.) (F. G. M.)

UNITED PRESBYTERIAN CHURCH OF NORTH AMERICA. This church was formed in May, 1858, by the union of the Associate Presbyterian Church and the Associate Reformed Presbyterian Church (see these titles). The basis of union was the Westminster Confession of Faith (with a slight modification) and Catechisms, and a Testimony, containing 18 articles or declarations of doctrine. Those having direct practical bearing, pronounced slaveholding a sin, disapproved secret societies, forbade the extending of

communion in sealing ordinances to persons who refuse adherence to the church's profession, and declared that in singing God's praise the Bible Psalms should be employed to the exclusion of uninspired human compositions. These declarations, practically held in common with the Reformed Presbyterian Churches (*q. v.*), yet serve to separate this body from the main Presbyterian Church. It may further be remarked that though this denomination can historically claim community of origin with the United Presbyterian Church of Scotland, it is in regard to Calvinistic orthodoxy at the furthest remove from that body.

The first General Assembly of the newly formed denomination met in Xenia, Ohio, in May, 1859. Its statistics show that it had 42 Presbyteries, 408 ministers, 634 congregations, and 55,547 members. The three synods of the Associate Reformed Presbyterian Church, namely, that of New York and the First and Second Synods of the West, formed a framework for grouping the Presbyteries. The General Assembly appointed the following boards to conduct the beneficent operations of the church: The Board of Foreign Missions, located at Philadelphia; Board of Home Missions, at Xenia, O.; Board of Publication, at Pittsburg; Board of Church Extension, at Allegheny, Pa.; Board of Education, at Monmouth, Ill. To these was added in 1863 a Board of Freedmen's Missions, at Allegheny, Pa.; and in 1873 a Board of Ministerial Relief, at Philadelphia; the latter being an expansion of an Aged Ministers' Fund, commenced in 1862.

The progress of the church has been steady. Its numbers have been increased by emigration from the north of Ireland as well as by accessions from those born in America. Its stronghold has been in Western Pennsylvania, but it has spread throughout the West, and has some churches on the Pacific coast. In 1865 Rev. W. C. McCune, of Cincinnati, then a minister of this church, published a book on *Close Communion*, advocating a wider extension of church privileges than the denominational *Testimony* allowed. He was tried by his synod and acquitted of teaching serious error, but appeal being taken to the General Assembly in 1867, that court found him guilty of maintaining serious error in regard to church fellowship. Mr. McCune withdrew to the Presbyterian Church, and afterwards passed to the Congregationalists.

The movement which had commenced in the various Presbyterian Churches of Scotch origin for the improvement of the Psalmody was continued in the United Presbyterian Church and resulted in the adoption by the Assembly of 1871 of a better metrical version of the Psalms. This newly authorized version has in a great degree superseded the Scotch version of the Psalms, often called Rous's version. In connection with the new version commendable efforts have been made to improve the singing in the churches. To this end the Board of Publication has prepared various editions of the Psalter with appropriate music. This movement led also to a discussion of the right to use instrumental music in the worship of God. The *Directory of Worship* which had been adopted by the action of the General Assembly and the Presbyteries in 1867 forbade such use on the ground that the Scriptures did not warrant it in the New Testament Church. But an increasing party grew restive under this restriction and an open controversy arose on the publication by Rev. D. F. Bonner of a pamphlet, *Instrumental Music Divinely Authorized* (1877). Several pamphlets were issued in reply to this. A vigorous movement for the repeal of the section forbidding instrumental music was begun and the question was submitted by the General Assembly to the vote of the Presbyteries. The vote as reported to the Assembly in 1881 was doubtful, but the Assembly declared the section repealed. This action was stoutly disputed, but each successive Assembly refused to reopen the question, giving various explanations of the position taken.

The advocates of instrumental music have in many cases introduced organs into their churches, and attempts to subject them to church discipline therefor have failed. Some congregations have been divided and the general work of the church has suffered, yet the annual reports to the Assembly continued to show advance in all departments.

In the midst of this controversy came in 1883 the twenty-fifth anniversary of the denominational organization. A special and vigorous effort was made to celebrate this quarter-centennial by liberal contributions to the beneficent work of the church. The net amount raised was \$369,668.86, which was distributed to the Mission Boards of the church, to its theological seminaries, to the denominational colleges, and to some local objects.

The United Presbyterian Church has been actively engaged in foreign mission work since its formation. From the churches which combined in 1858 it received under its care missions in Egypt, India, and Syria. In 1859 it started a new mission to China, but after several years of labor in that field the General Assembly decided to leave it to other denominations and the missionary was recalled to labor among the Chinese in California. The mission in Syria was likewise transferred to the Irish Presbyterian Church, which had already been associated in the work. The United Presbyterian Church has concentrated its efforts in Egypt and India (the Punjab), and its success has challenged the attention of all visitors to those countries. In both there are theological training-schools for the natives, and several churches have native pastors.

In Egypt there are 85 mission stations, 11 ordained missionaries, 10 female missionaries, 10 native pastors, 2307 communicants, and 5601 pupils, the mission property being valued at \$207,810. In India there are 69 stations, 8 ordained missionaries, 11 female missionaries, 12 native pastors, 4571 communicants, and 4341 pupils, the mission property being valued at \$29,922.

The statistics of the United Presbyterian Church for 1888 show 10 synods, 61 presbyteries, 753 ministers, of whom 507 are pastors, 57 licentiates, 42 students of theology, 3580 ruling elders, 907 congregations, of which 614 have pastors, 150 mission stations, 159 parsonages, 98,992 communicant members, 953 Sabbath-schools, with 9815 officers and teachers, and 86,450 scholars. The total contributions for the year ending April 30, 1888, were \$1,019,937, of which \$783,120 were for congregational purposes.

The church has two theological seminaries. That of the conservative wing is at Xenia, Ohio, and is the successor of the oldest seminary in the United States (see THEOLOGICAL SEMINARIES). The other, more flourishing, is at Allegheny City, Pa. Westminster College, New Wilmington, Pa., and Monmouth College, Monmouth, Ill., are denominational colleges of many years' standing and established reputation. Lincoln College, Mo., and Cooper Memorial College, Kansas, are of recent origin, and are still struggling for existence. Muskingum College and Franklin College, older institutions in Ohio, are largely patronized by United Presbyterians. At Knoxville, Tenn., is a college for the Freedmen, conducted by United Presbyterians.

Besides Sabbath school papers and other periodicals issued by the Board of Publication at Pittsburg there are published in the interest of this church two weekly papers, *The Christian Instructor*, at Philadelphia, and *The United Presbyterian*, at Pittsburg, and also a monthly, *The Evangelical Repository*, at Pittsburg.

See Rev. Dr. J. B. Scouller's full and accurate *Manual of the United Presbyterian Church* (2d ed., 1887), and Rev. Dr. W. J. Reid's *United Presbyterianism* (1886). (J. P. L.)

UNIVERSALISM is commonly thought to mean

belief in the final salvation of all men. The system of faith which passes under this name cannot be characterized in this way. The result here predicated is but a corollary or inference from a theological conception which regards God as a moral being working by moral methods for the accomplishment of moral ends. The principles of his nature are declared to be universal in their application and issue.

History.—This view is not modern. The apostles taught that God is love and that love sent the Saviour into the world. Their successors held to this conception and stated it with positiveness. Great leaders of the Greek Church, like Clement of Alexandria and Origen, maintained by specific arguments that love must triumph in the ultimate recovery of every soul. This view prevailed until the sceptre of authority passed from the Eastern to the Western branch of the church. Then a purely legal conception of the divine nature and government, of sin and penalty, and of redemption was substituted for the moral. Augustinianism came to prevail almost exclusively until the rise of Protestantism. The latter movement produced the modifications known as Lutheranism and Calvinism. The Reformed theology of England was for the most part that taught by Calvin. The Westminster divines sought to put Calvinism into a popular form. This was the theology which the early settlers brought to this country. The whole English-speaking race at the beginning of the eighteenth century gave almost unqualified assent to it.

But very early in the century there began to be marked symptoms of dissent. Arminianism in England, and, later on, the Arminian and Socinian tendencies in America, were the signs of a protest in the bosom of Protestantism against Calvinistic predestination and election. During this upheaval the modern Universalist movement had its birth. It began on the other side of the water, but was soon transferred to America. Dr. Eddy, in his work entitled *Universalism in America*, mentions five distinct channels by which the doctrine was brought hither: 1. Dr. George De Beneville, one of the French refugees in London, 1703, after expulsion from England because of his heretical opinions, and after barely escaping death from the same cause in France, came to America in 1741, and settled in Pennsylvania, where he practised medicine and preached in different parts of the State until his death, in 1793. 2. The German Baptists, commonly called Dunkers (*q. v.*), who settled in Pennsylvania in 1719, were from the first believers in the universal restoration. 3. The Rev. Richard Clarke, rector of St. Philip's Church, having a European reputation, was pronounced in his advocacy of the doctrine. He had strong sympathizers among leading men of his denomination in different parts of the country. 4. Among the Congregationalists, the attitude of Dr. Charles Chauncey, pastor of the First Church of Boston, and of Dr. Jonathan Mayhew, of the West Church, is well known. 5. But the Universalist denomination of to-day traces its origin to the Rev. John Murray (1741-1815), who came from England to this country and preached his first sermon in Thomas Potter's church, at Good Luck, N. J., Sept. 30, 1770. Murray at twelve years of age had come under the influence of John Wesley, who honored him with his confidence, so that he became, a few years later, an advocate in his connection. But upon hearing Whitefield he adopted Calvinistic views, and became a communicant in his Tabernacle. Here he was so marked by his zeal and ability that he was specially commissioned to reclaim a young lady of the congregation who had adopted the views of James Rely, a Universalist preacher of London. The young lady was strong in her convictions, and by questions and answers raised problems in his mind which troubled him sorely. Next he began to read Rely's *Union*, a small theological treatise, and became a regular attendant upon his preaching. Completely converted to what was then

known as "Rellyism," he was then urged to become a preacher of the new faith, but declined. After the death of his wife he emigrated, hoping that he might bury himself in the wilderness. But after resisting by every means the solicitations of Mr. Potter, he consented to preach in the house which the latter had built in the confident expectation of a preacher whose views corresponded with his own. Murray at first thought he would spend his days as a kind of private chaplain to his new-found friend and his immediate neighbors. But people flocked to hear him from miles around. He says: "Solicitations, earnest solicitations, poured in from the Jerseys, from Philadelphia and from New York; and it became impossible to withstand their repeated and imposing energy." He entered upon a series of missionary journeys which carried him as far north as Portsmouth, N. H. As early as 1773 he had made several visits to Rhode Island, preaching to large congregations in Newport, East Greenwich, and Providence. He formed life-long friendships with Gen. Nathaniel Greene and other distinguished Rhode Island patriots.

Mr. Rely held that the atonement was complete. All men had fallen in Adam, through "union" with him had actually participated in his transgression, and therefore merited damnation. But in like manner all, through "union" with Christ, the second Adam, had entered into the atonement. Their redemption, though not their salvation, was complete. Murray accepted this doctrine without qualification. Supposing himself to be entirely alone in his views on this continent, he did not make formal announcement of them, but confined his expression entirely to the language of the Scriptures. Hence his deviation from orthodoxy for some time was not suspected, and churches of the standing order were freely opened to him. But as men came to have a clearer understanding of his opinions he encountered opposition. While preaching in Boston in 1774 his life was threatened. Visiting Gloucester, Nov. 3, 1774, he found several persons who had read Rely's *Union*, and were thoroughly in accord with its teachings. Being invited to settle in Gloucester, he accepted, and barring the term of his chaplaincy in the army, resided here until his removal to Boston, in 1793, where he remained until his death. Through Murray's influence a number of societies were established in different parts of the country. Among his associates in the work of the ministry may be mentioned Adams Streeter, Caleb Rich, Edward Mitchel, George Richards, a man of lofty eloquence and literary power; Walter Ferris, Elhanan Winchester, and Hosea Ballou.

Mr. Ballou exerted a greater influence than Murray upon the Universalist denomination and theology. He was born in Richmond, N. H., April 30, 1771, of Baptist parentage, but before he was 18 years old he had become persuaded that the Scriptures taught that the grace of God is universal, and a few years later he had cast aside the commonly received notions of the Trinity, and the atonement. After being ordained to the ministry in 1794 his settlements were Dana, Mass.; Barnard, Vt.; Portsmouth, N. H.; Salem, and Boston. In the autumn of 1798 he supplied Mr. Murray's pulpit for ten weeks. "On the last day of his ministrations he gave a very frank and clear explanation of his new views touching Christ and the atonement." The occasion is historic. It marks a new departure in the Universalist theology of the period. From that time every vestige of Calvinism was swept out of the Universalist faith. In 1804 Ballou published *Notes on the Parables of the New Testament*, and in 1805 his *Treatise on the Atonement*. Horace Greeley and others have called this the most remarkable book of the century. It was remarkable, if it be remembered, that a young man without formal education, unacquainted with the literature of theology, without commentaries, with nothing but the English Bible, had substituted the moral for the legal view of the atonement,

and produced a system of theology, with Christ as the mediatorial agent for bringing the moral universe into voluntary subjection to the power and love of God. His theology, however, has never been wholly acceptable to the Universalist body. He held an extreme view of the Divine sovereignty which gave an Antinomian tinge to his teaching. His theory that "the Scriptures begin and end the history of sin in flesh and blood, and that beyond this mortal existence the Bible teaches no other sentient state but that which is called by the blessed name of life and immortality," gave rise to the Restorationist movement, and led many to feel that the Universalist view of sin is superficial and frivolous. Yet, under his influence, the denomination had a phenomenal growth. People flocked in multitudes to hear his messages, and he drew into co-operation with him men whose intellectual gifts were only inferior to his own. Mention should be made of Walter Balfour, whose examination of the meaning of the terms Sheol, Hades, Tartarus, and Gehenna, led to interpretations which have now been accepted by the foremost scholars and Biblical critics of the Protestant world; Thomas Whittlemore, an unrivalled controversialist, and Lucius R. Paige, known by his books, *Selections from Eminent Commentators*, and *Commentary of the New Testament*. The historical outline of Universalism would not be complete without reference to two other men, who, though belonging to a later generation, were contemporaries of Hosea Ballou in the formative period of the denomination. The first is Hosea Ballou, second editor of the *Universalist Quarterly Magazine*, from 1844 to 1861, and the first president of Tufts College; a scholar of the first rank. The second is Thomas J. Sawyer, the dean of Tufts Divinity School. To these two men the denomination is indebted for the shaping of its theology, and for the educational impulse which has been a conspicuous feature of its later history.

The General Convention, at its session in Winchester, N. H., in 1803, adopted the following:

I. We believe that the Holy Scriptures of the Old and New Testaments contain a revelation of the character of God, and of the duty, interest, and final destination of mankind.

II. We believe that there is one God, whose nature is love; revealed in one Lord Jesus Christ, by one Holy Spirit of grace, who will finally restore the whole family of mankind to holiness and happiness.

III. We believe that holiness and true happiness are inseparably connected, and that believers ought to be careful to maintain order and practice good works, for these things are good and profitable unto men.

This profession has remained the only test of fellowship until the present time. There is, however, a large and increasing minority who object to it on the ground, first, that the last clause of the second article seems to imply the doctrine of the fall of the race through the transgression of Adam; and secondly, that the third article is utilitarian in its philosophy. A committee has been appointed by the General Convention to consider the matter of revision.

Polity.—Universalists originally for the most part were drawn from the Congregationalists. Accordingly the polity of the church has Congregational features. In the individual churches the people have the controlling voice in settling ministers and directing parish affairs. The parishes are organized into conventions confined to the limits of the several States, the General Convention being over all. The State conventions are composed of the clergymen in fellowship, and of lay delegates chosen by the parishes. Discipline is in the hands of a committee of fellowship, appointed by each convention. The General Convention is a delegate body, meeting, after 1889, biennially. Delegates, clerical and lay, in certain definite proportions, are chosen by the State conventions. It is also a corporate body, having a board of trustees, who

are charged with matters of discipline, finance, and missionary effort. The General Convention was chartered in 1866. The present organization dates from 1870.

Statistics.—The whole number of ministers is 710. There are 926 parishes, comprising about 40,000 families. The church-membership is upwards of 37,000. There is a Sunday-school membership of nearly 53,000. The estimated value of church property is \$7,500,000. The permanent funds of the general convention aggregate nearly \$200,000. During the last thirty years particular attention has been given to the establishment and development of educational institutions. Besides such seminaries as Clinton Liberal Institute, in New York; Goddard Seminary, in Vermont; Westbrook Seminary, in Maine, and Dean Academy, in Massachusetts, all well endowed, there are four colleges and three theological schools. The colleges are Tufts College, St. Lawrence University, Lombard University, and Buechel College. With each of the three first-named colleges a theological school is connected. The aggregate of funds permanently devoted to educational purposes is not less than \$3,000,000. Upwards of 100 teachers are employed, and instruction is given to nearly 1400 pupils annually. (E. H. C.)

UNIVERSITIES. See COLLEGES.

UPHAM, CHARLES WENTWORTH (1802-1875), author, was born at St. John's, N. B., May 4, 1802. His father, Joshua Upham (1741-1808), was a judge in Massachusetts, but taking the Tory side in the Revolution, removed to New Brunswick, where he became member of the governor's council. Charles returned to Boston in childhood and graduated at Harvard in 1821. Three years later he was ordained as a pastor in Salem, but after twenty years' service he was obliged to give up preaching on account of loss of his voice. Meantime he had already served in the Legislature, and was afterwards a member of the State Senate, and its president in 1857-58. He was also a member of Congress 1853-54, and took part in the original organization of the Republican party. He died at Salem, June 14, 1875. He had always been busy in writing for the press; his *Lectures on Witchcraft* (1821) was afterwards expanded into two volumes (1867); he edited the *Christian Review*, quarterly, and the *Christian Register*, weekly; and prepared several biographies: *Sir Henry Vaue* (1835) for Sparks' *American Biography*; *Fremont* (1856); *Francis Pickens* (1869), and completed the *Life of Timothy Pickens* (5 vols., 1867-72), which had been left unfinished by O. Pickens. He also prepared a *Life of Washington*, made from the general's letters, but withheld it out of regard for Sparks' edition of the *Writings of Washington*. A surreptitious edition, however, appeared in England in 1852.

UPHAM, FRANCIS WILLIAM, educator and author, was born at Rochester, N. H., Sept. 10, 1817. He graduated at Bowdoin College in 1837, studied law and was admitted to the bar in 1844. He afterwards devoted himself to teaching in New York city, where he was professor of mental and moral philosophy in Rutgers Female College, 1867-70. Being greatly influenced by the views of Prof. Taylor Lewis, he has published not only a defence of these views, but also other religious works, containing peculiar and ingenious speculations. They include *The Wise Men* (1869); *The Star of Our Lord*, or *Christ Jesus, King of all Worlds* (1873); *Thoughts on the Holy Gospels* (1881).

UPHAM, THOMAS COGSWELL (1799-1872), author, was born at Deerfield, N. H., Jan. 30, 1799. His grandfather, Timothy, had been the pastor of the Congregational church there for many years, his father, Nathaniel, had been a member of Congress for three terms, and his uncle, Timothy, was an officer in the war of 1812. Thomas graduated at Dartmouth College in 1818 and at Andover in 1821. Here he became tutor of Hebrew, but in 1823 he was made associate-pastor at Rochester, N. H. In 1825 he was called to Bow-

doin College, and there held the chair of philosophy for forty-two years. During this time he prepared his *Elements of Mental Philosophy*, in three volumes, treating respectively of the intellect, sensibilities, and will. An abridged edition also had a large circulation as a text-book in schools. He also published *Life and Opinions of Madame Guyon* (1847); *Life of Faith* (1848); *Divine Union* (1851); *Letters from Europe, Egypt, and Palestine* (1857). He resigned his professorship in 1867, and took up his residence at Kennebunkport, Me. He died at New York city, April 2, 1872.

UPTON, EMORY (1839-1881), general, was born Aug. 27, 1839, at Batavia, N. Y. He was brought up on a farm, and spent the winter of 1854-55 at Oberlin College, Ohio, but in 1856 entered the U. S. Military Academy at West Point. He graduated on the outbreak of the war in 1861, and was assigned as 2d lieutenant to the 5th regiment of artillery. On May 27 he was selected as aide to Gen. Tyler, and as such was present at the first battle of Bull Run, where he was wounded. On his recovery he was assigned to the command of a battery in the U. S. artillery in Franklin's division, and was commended by that general and again by Gen. Slocum for skill and bravery in the Seven-days' fight. At the battles of Crampton Gap and Antietam, Upton was in command of an artillery brigade of 26 guns which he handled with marked efficiency. In October, 1862, he was appointed colonel of the 121st N. Y. Volunteers, and so distinguished himself at Salem Heights (May 3, 1863) that, at Gettysburg, he was intrusted with the command of a brigade. Holding the same position he took part in the assault on the Confederate intrenchments at Rappahannock Station (Nov. 7, 1863). He participated in Gen. Grant's Wilderness campaign in May, 1864, and distinguished himself particularly in the indecisive battle at Spottsylvania Court-House. Promoted brigadier-general of volunteers, in May, 1864, he took part in the defence of Washington in July, as well as in Sheridan's campaign against Early in the Shenandoah Valley, again distinguishing himself at the battle of Winchester (Oct. 9, 1864), where he was severely wounded. He was then promoted major-general of volunteers, and, on his recovery, was assigned to the command of the fourth division of the cavalry corps under Gen. J. H. Wilson and participated in that general's operations in Alabama and Georgia, from March to May, 1865, taking part in the capture of Selma and Columbus. On March 13, 1865, he was promoted brevet major-general U. S. A. At the close of the war he was assigned to the command of the district of Colorado with headquarters at Denver. Devoting himself now to the study of tactics, he developed the system used in the U. S. army under his name. In 1875 he was sent out by the government as a special commissioner to investigate the military condition of the various countries in Asia and Europe, and gathered valuable material for his authoritative work on the military policy of the United States. On being mustered out of the volunteer service in April, 1866, he resumed his rank as captain in the 5th regiment of artillery, but in July he was made lieutenant-colonel of the 25th infantry; and in 1870 was appointed commander of cadets in West Point, which office he held for five years. On his return from his foreign tour in 1877, he was assigned to duty at the artillery school of practice at Fortress Monroe. He died by his own hand, March 14, 1881, at Presidio San Francisco, whither he had gone in the close of 1880 to assume command of the 4th artillery, of which he had been appointed colonel. His death is attributed to despondency caused by chronic catarrh. His publications were his standard work on *Infantry Tactics* (1867) and his *Armies of Asia and Europe* (1878). Prof. Michie has published his *Memoir* (1885).

USURY is the excess over the legal rate charged to a borrower for the use of money. The legal rate is

fixed by statute in each State; if there be no statute there can be no usury in a legal sense. See Vol. XXIV. p. 17 (p. 22 Am. Rep.). If there be a loan in contemplation of the parties, no matter how it may be disguised, the contract is usurious if it be so in other respects. The *bona-fide* sale of a note, bond, or other security at a greater discount than would amount to legal interest has been held not to be necessarily a loan, though, if the note was made with a view to evade the law against usury, the transaction would be construed a loan. Both parties must be cognizant of the facts which make the contract usurious. It has been held that a mistake in regard to the law will not protect the parties, though a miscalculation will. A mortgagor may, however, agree to pay a tax on the mortgage in addition to the full legal rate of interest. The ordinary commissions in the course of trade may be charged without making a contract usurious, though not so if they are charged as a means of evading the law. A commission charged in addition to interest for advancing money is usurious. A gratuity given to influence the making of a loan has been considered to be usurious. The reserving of interest on negotiable paper at the time of making the loan does not make the contract usurious, though the borrower is thereby made to pay more than the legal rate. The borrower must be obliged to return the principal together with more than lawful interest. Parties may contract for interest according to the place of the contract or the place of performance. In the absence of such agreement the transaction will be governed by the law of the place of the contract. When a dispute about interest is taken before a court the burden of proof is on the person pleading usury.

Usury may be set up as a defence by the person who has contracted to pay usurious interest, or by his sureties. A usurer, however, cannot take advantage of his usury to avoid his contract.

It is generally provided by the statutes of the States that the excess over the legal rate of interest is not recoverable.

The act of Congress of June 3, 1864, provided with reference to the national banks that they might take interest at the legal rate of the State, Territory, or District where the bank was located, except that in a State where the State banks were permitted to take a higher rate, the national banks might do the same. If no rate was fixed by the law of the State, Territory, or District, the banks might not exceed 7 per cent. It was further provided that the penalty for taking a greater amount of interest than that allowed by the act should be deemed a forfeiture of the entire interest carried by the note, bill, or other evidence of debt; also that where such interest had been paid, twice the amount thereof might be recovered back by the person who had paid it, provided the action was begun within two years. Under this act it has been held that as Congress is the sole judge of the necessity for national banks, and has created them, the States cannot exercise control over them or in anywise affect their operation, except so far as Congress may permit; consequently the penalty prescribed by the Act of 1864 for the exaction of usurious interest is superior to and exclusive of any State penalty. It has also been held that a national bank is not justified in charging usurious interest because the statute of the State permits specified banks to do so. (T. R.)

UTAH. See MORMONS.

UTILITARIANISM. See CONSCIENCE.

V.

VACCINATION. This operation consists in the inoculation of the human subject with the lymph of cow-pox or kine-pox (*vaccinia*), for the special purpose of preventing an attack of small-pox (*variola*), and it is believed to be almost as sure protection against that loathsome disease, when properly performed with pure virus, as is small-pox itself a protection against a second attack. Furthermore, it modifies the severity of small-pox and greatly reduces the death-rate from that disease in its modified form, *varioid*. To Edward Jenner, an obscure apprentice and country physician at Sodbury, near Bristol, Eng., is due the credit of discovering the prophylactic properties of vaccinia, his attention being first called to the immunity from small-pox of persons connected with the care or milking of cows, and whose hands became sore from coming in contact with the udders and teats of cattle suffering with a peculiar eruption about those parts. He first published to the world his great discovery in 1798, after a series of observations and experiments extending over a period of twenty years, and although bitterly opposed at first, his name has become immortal among all civilized nations as one of the greatest benefactors of the race.

The phenomena resulting from vaccination are: A slight papular elevation is observed at the point of inoculation (usually about midway between the elbow and shoulder) on the evening of the second or morning of the third day after the operation, becoming more distinct and reddened on the fourth day, and presenting a bluish-white vesicle about the fifth or sixth day, with raised, firm edges and marked central depression (umbilicated) on the seventh day. The pock attains its growth by the eighth day, and appears as a plump

round, pearl-colored vesicle, distended with clear lymph elevated two or three lines, and measuring about one-third inch in diameter. At this time a circular ring of inflammation or areola forms about the base of the pock, increasing for a day or two in redness, and measuring from one to three inches in diameter; considerable hardness and swelling may occur in the adjacent tissues, with pyrexia and some local pain and pruritus; occasionally there is inflammation and swelling of the lymphatics of the arm and glands of the axilla. About the tenth day the areola begins to fade, the pyrexia to subside, and a dark spot is seen on the centre of the vesicle, which gradually concretes and becomes opaque, forming a hard scab by the fifteenth day, and falling off about the twenty-fifth day from the date of vaccination, leaving a circular, depressed and somewhat foveated cicatrix, which usually remains visible through life.

Vaccination should be performed in early life, as the susceptibility to small-pox exists at all ages. An infant, if healthy, may be vaccinated after the second month, or even earlier, if exposed to the contagion, care being taken to use only pure vaccine, and it is better perhaps at so tender an age to use humanized lymph (not too far removed) instead of bovine. The length of time during which the protection afforded by vaccination exists has been variously stated—the "seven-year" theory having many advocates. No rule can be laid down on this point, and the safest plan is to revaccinate whenever an epidemic of small-pox occurs in the vicinity or an exposure to the disease has happened. Even if no epidemic or exposure occurs it is good practice to revaccinate those who have indistinct scars or who have not been vaccinated since infancy. Flint recommends revaccination every five years.

The procuring of *pure vaccine* is the most important practical point connected with vaccination, and upon this too much stress cannot be laid; the difficulty of obtaining it is in fact at the bottom of all present opposition to humanized virus (except, of course, the few non-believers in the whole subject of vaccination), and in this country bovine virus has nearly superseded the use of the old-time "scab" or "crust" and "vaccine tubes." Quite recently (1887) John B. Buist, M. D., F. R. S. E., in his book, *Vaccinia and Variola, a Study of Their Life History*, says: "The difficulty which is encountered in determining the cause of many infective diseases lies in the circumstance that no definite bacteric form peculiar to them can be isolated; and this is occasioned by the minute forms in which such contagia generally exists. Improved methods of histological investigation, by means of different staining materials and improved magnifying and illuminating apparatus, have now made it possible to define forms which were formerly beyond the range of human vision. . . . Experimental vaccination appears to prove that the potency of vaccine materials varies in a remarkable degree, in proportion to the quantity and quality of their active principle. . . . The form of bacterium present in clear vaccine lymph is a very minute spore, .15 μ in diameter, and if the lymph be dried immediately the further development of the spore is prevented. Its activity can be revived by moistening the dried film of lymph with water, and this material, when properly employed, produces perfect vaccination. Between this minute body and the large torula (2 μ to 5 μ) cell in opaque lymph, there is apparently no more connection than there is between an acorn and an oak, but there are certain close analogies between vaccine lymph and yeast. In Great Britain, "clear vaccine lymph, carefully taken from typical vesicles in healthy subjects (arm-to-arm vaccinations), is regarded by the authorities of the National Vaccine Establishment as the most perfect material for vaccination that can be obtained. Opaque or opalescent lymph is regarded as an inferior or imperfect material for vaccination, on the ground that complaints used to be frequent, on account of its too energetic qualities. Vaccine lymph is said to be clear when it shows no opalescence by reflected or obliquely transmitted light, and when it is free from blood or other impurities. It is said to be opaque when it appears slightly milky, or opalescent when tested in the same way. One of the great difficulties of vaccination is the propagation of a material which remains perfectly clear for a time after being stored. . . . It is found that vaccine lymph is most certain in its action when transferred directly from the arm of one child to that of another, good vesicles being easily produced by a single or a double scratch thus: . . . If this same material be stored in a tube for even half an hour, it is found that the same result cannot be produced unless the operation is done thus: . . . and the lymph well rubbed in it. This explains why many vaccinations fail with clear lymph, especially if they are in the habit of vaccinating from arm to arm. The material has changed in potency, and a more severe operation is required for its successful insertion. When a cover-glass preparation of clear lymph is examined microscopically, it shows minute isolated spherical organisms, about .15 μ in diameter. This is the true bacteric form of the perfect vaccine material, which does not contain any larger organisms. When the lymph is dried, these organisms are preserved from developmental changes, and the material undergoes no other change in quality than is common to stored lymph generally. . . . Opaque vaccine lymph, unless originally clear and carefully stored in well-filled sterilized tubes, from which the air has been expelled during the sealing process, must be regarded as an imperfect material for vaccination. . . . Experience teaches that opaque lymph is an imperfect vaccine material. It is more energetic locally than clear lymph, and in former times eruptions

were frequently produced by its use, especially when the lymph was taken too late."

Owing to the supposed deterioration of humanized lymph (*i. e.*, vaccine obtained from previous vaccinations) and the opposition to its use by many who fear the introduction of other diseases, bovine lymph has almost entirely superseded its employment in this country. The "Beaugency stock," imported to the United States in 1870, by Dr. Henry A. Martin, of Boston, is perpetuated through successive inoculations of heifers, being first obtained from a cow at Beaugency, France, in 1866, in which a "spontaneous" appearance of cow-pox was observed. The inoculation of heifers is performed by securing the animal upon its back, in a frame made for that purpose, shaving the parts adjacent to the udder, and introducing the virus at many points over the denuded surface, which is first thoroughly cleansed. The scarifications are protected by fastening a cloth over the parts, and in due time the vesicles appear. When filled with lymph, on the seventh or eighth day, the calf is again secured as before, and ivory points or quills are "charged" with the virus as rapidly as possible, dried, and hermetically sealed, or otherwise protected from the air. It is a remarkable fact that bovine virus does not retain its potency as long as the humanized, and for this reason the ivory points or quills are not guaranteed by those furnishing them beyond two or three weeks. No lancet is required in the operation, as each point or quill is sharpened at the end sufficiently to scarify the place of inoculation, care being taken to first dip it in water to liquify the virus. Simply removing the outer or scarf-skin with the ivory point, or making cross cuts thus . . . with a lancet, without drawing blood, is deemed the best practice. It is claimed that better protection results if more than one, say four or five vaccinations, are made (see table below), and that the inconvenience or discomfort from inflammatory action, etc., is not thereby increased; this applies more particularly to humanized vaccine.

The following classification of 5000 patients—extending over twenty years—afflicted with small-pox, shows the percentage of deaths in each class represented (Marson):

Classes.	Per cent. of deaths.
I. Unvaccinated.....	35.00
II. Stated to have been vaccinated, but showing no cicatrix.....	23.57
III. Vaccinated— <i>a</i> , one cicatrix.....	7.73
<i>b</i> , two cicatrices.....	4.70
<i>c</i> , three ".....	1.95
<i>d</i> , four or more cicatrices..	0.55
<i>a</i> , well-marked ".....	2.52
<i>b</i> , badly ".....	8.82
IV. Having previously had small-pox.....	19.00

The history of the introduction of vaccination into this country shows the same bitter opposition by both the medical profession and the people as marked its early introduction in other countries. Dr. Benjamin Waterhouse, of Cambridge (formerly of Newport), and Dr. James Smith, of Baltimore, are each given the credit of the first vaccinations in the United States. In June, 1800, Waterhouse, who was then professor of theory and practice of medicine in Harvard, and who had obtained all the information possible regarding Jenner's great discovery, succeeded after several fruitless efforts in obtaining upon a cotton thread a small quantity of pure vaccine from England, and on July 8 inoculated one of his sons, then five years of age. This he followed in a few days by vaccinating others in his family, six in all, among them an infant of one year. He then applied the crucial test by sending the children to the small-pox hospital at Brookline, within two months after their vaccination, where they were not only freely exposed to the contagion of small-pox but also inoculated with variolous matter, the only result observed being a very slight irritation at the

points of the insertion of the virus; there was no constitutional disturbance whatever. Waterhouse very truly remarks: "One fact in such cases is worth a thousand arguments" (*The Jenner of America: an address delivered before the Philadelphia Co. Medical Society by W. M. Welch, M. D., 1885*).

Notwithstanding his successful experiments with vaccination, all efforts to establish a vaccine centre in Boston failed; but Waterhouse had a firm friend in Thomas Jefferson, President of the United States, to whom he sent vaccine, and who in turn supplied physicians in the District of Columbia, Pennsylvania, Maryland, Virginia, and other States still farther south, also the Indians; studying the phenomena of the disease himself very closely, and learning by observation that the proper period for collecting the virus is "eight times 24 hours from the time of its insertion." This rule, which the President himself observed carefully and with uniform success, he was particular to communicate to all to whom he sent virus (Welch). Waterhouse made repeated efforts to establish a vaccine institution in Boston, but failed, though his perseverance finally settled the question of the value of vaccination in the following manner: The Board of Health of Boston appointed a committee of seven of the most reputable physicians of the city, who on Aug. 16, 1802, vaccinated nineteen children at the health office. On Nov. 9 these children were sent to Noddie's Island, and there inoculated two different times with variolous matter, besides being exposed for twenty days to the *contagium* of small-pox without manifesting the slightest indisposition. The report of the committee concludes with this remark: "The cow-pox prevented their taking the small-pox, and they do therefore consider the result of the experiment as satisfactory evidence that the cow-pox is a complete security against the small-pox" (Welch). A similar test at Randolph, Vt., where the question of inoculation with small-pox vs. cow-pox was to determine the efficacy of the latter; a town-meeting was held, a committee appointed, and 75 persons who had been vaccinated were then inoculated with the small-pox virus taken warm from the pustules of patients covered with them, and not one of the number was found susceptible to small-pox. The committee, however, was not satisfied, and desired to find some woman with a sucking child who would be willing to let her infant be vaccinated and herself have small-pox. Waterhouse says: "Mrs. M—heroically offered herself for the experiment. The infant was first inoculated with kine-pox, and forty-eight hours afterwards its mother was inoculated with small-pox. The kine-pox went on regularly in the child, and so did the small-pox in the mother, who suckled the child all the time. The mother had a considerable number of pustules on her body, face, and breasts; one or two of which were kept raw by the tender lips of the infant while sucking; and yet the child appeared as well throughout the whole process as if it had not been nursed by a person suffering under small-pox" (Welch).

Dr. Henry A. Martin says of the opposition to Waterhouse by the clique of Boston physicians that it "did all it could to oppose vaccination (as taught by Jenner), to hinder, vilify, and persecute the noble man, who, in the face of obstacles innumerable, struggled for the truth and won—won what? Poverty, persecution, bitter and mendacious, and a fame so great and lasting that only here and there an eccentric student knows more than his name" ("Jefferson as a Vaccinator," *N. C. Med. Journal*, January, 1881). In 1810 he petitioned the Legislature of Massachusetts to reimburse him for the work he had done, having impoverished himself by his long-continued efforts in establishing vaccination in his own and other States. The Legislature satisfied itself by permitting him to withdraw his petition! In a letter to an old friend in England he says: "For the honor of my country I

am ashamed to tell Dr. Jenner how I have been treated by our Legislature respecting remuneration. I have received nothing but abuse, nay, more, I have been intrigued out of my place as physician to the U. S. Marine Hospital, with 500 sterling a year, and given me by Jefferson as a reward for my labors in vaccination, and this merely in consequence of his going out and others coming in, so that, at 56 years of age, I have now to contrive and execute some new plan to supply this deficiency." After he was forced out of the university by his jealous associates, President Madison, knowing of his unfair treatment, gave him military supervision of the nine posts of New England.

Dr. James Smith, of Baltimore, began vaccinating in that city in the spring of 1801, contemporaneously with Waterhouse's second effort in Boston, but, unlike him, met with no opposition professionally or otherwise; "on the contrary, the profession of Baltimore, including almost the entire faculty, gave public and early expression of their approval," and vaccine virus was distributed through his efforts "over Pennsylvania, New York, New Jersey, Delaware, Maryland, Ohio, Kentucky, Virginia, North and South Carolina, and other States, and even to the West Indies and South America" (*The Introduction of Inoculation and Vaccination into Maryland Historically Considered*—Address by J. R. Quinan, M. D., Baltimore, 1883). It is stated by Dr. Quinan that the first virus received into Baltimore was by Dr. John Crawford of that city in the summer of 1800, contemporaneously with the first received by Waterhouse. Notwithstanding the assistance given Dr. James Smith, he, too, became impoverished in his enthusiastic efforts to disseminate the "new inoculation," as it was then called. The vaccine institute established by him and his associates in 1802, and his work to further its beneficial effects, rendered him almost penniless, and when in 1809 the Legislature enacted a law to establish an institution for the free distribution of matter he tried to obtain an appropriation but failed. A lottery was then tried, but as it had to compete with the Washington Monument Lottery it also failed. Subsequently he succeeded in mortgaging his private property and establishing a vaccine institution in the city; and in 1813, Congress having established a U. S. vaccine agency, Dr. James Smith was appointed without pay to fill the position of agent, which he held till 1822, when it was abolished (Quinan). Like Waterhouse he early subjected his two sons and other members of his family to small-pox inoculation as a proof of the efficacy of vaccination, and supported twenty special agents with horses and virus to gratuitously vaccinate all who would submit to it.

From the date of these two noble men to the present time the work of vaccination in this country has been going on, until now there is not a city, town, or hamlet in which it is not practised; nor is there one in which epidemics of small-pox are not always successfully met by vaccination; and in most of them there are laws or ordinances compelling vaccination of their school-children, if not of their entire population.

Revaccination.—Although the protection of a successful vaccination is absolute for the time being, accumulative evidence goes to prove that it is not permanent and that revaccination is necessary to thoroughly protect the individual and the community. To insure perfect immunity from the ravages of small-pox it is therefore necessary to revaccinate from time to time. Dr. Wm. M. Welch, physician in charge of the Municipal (small-pox) Hospital, Philadelphia, says:

"Some of the earliest and most conclusive proofs of the value of revaccination are furnished as the result of experience in the Wurtemberg, Bavarian, and especially in the Prussian armies. Among 14,284 re-

vaccinated soldiers in Wurtemberg only *one* case of small-pox occurred in *five* years, and only *three* among 26,964 revaccinated civilians. During three severe epidemics of small-pox in Copenhagen, between the years 1828 and 1835, not even a single instance of varioloid was observed among any who had been vaccinated. . . . It is due to Germany to say that vaccination is nowhere more carefully and thoroughly performed than in that country. It was there that revaccination was first practised and has ever since continued to be systematically performed. . . . During the Franco-Prussian war small-pox prevailed to an alarming extent, and both armies were freely exposed to the contagion; but the loss by death from that disease in the German army was only 263 men, against 23,468 in the French army, and the latter army was at no time much more than one-half the size of the former. In joining the French army vaccination was not a prerequisite, and revaccination was in nowise compulsory. Among the most conclusive proofs of the efficacy of revaccination is that furnished by statistics of small-pox hospitals. After thirty years of labor at the hospital of London, Marson asserted that but few patients were admitted who had been revaccinated with effect, and that these few had varioloid in a very mild form. During his connection with the hospital he revaccinated all the nurses and servants, who had not had small-pox, on their coming to live at the hospital, and not one of them contracted the disease. At a time, however, when a large number of workmen were employed about the hospital, most of them consented to be revaccinated, but there were a few who declined. Of the latter two took small-pox, while the former enjoyed perfect protection.

"The medical superintendents of the several small-pox hospitals of London report that during the period from 1876 to 1879, when 11,412 cases of the disease occurred among vaccinated persons, not one case was known to occur in any person who had been successfully revaccinated. Of the nurses and servants employed at the various hospitals, numbering in all about 1000, some half dozen only contracted the disease, and these for some cause or other had escaped revaccination before entering the wards."

Dr. Welch concludes by saying that his twelve years' service entirely agrees with the above, and that no employé or attendant who had been revaccinated before entering on duty had suffered with the disease.

The question of the identity of small-pox and cow-pox virus, while still discussed, is now pretty generally decided in the negative, and the efficacy of horse-pox vaccine as a protection against small-pox has also been decided the same way. Retro-vaccination (from man to cow) is uncertain and not to be encouraged, the only pure source being the "spontaneous" vaccinia of the cow, which is continued and kept pure through the vaccination of healthy heifers. (P. II. B.)

VALENTINE, EDWARD VIRGINIUS, sculptor, was born at Richmond, Va., Nov. 12, 1828, his father being a merchant in that city. He went to Europe in 1859 and studied first with Couture at Paris, then at Florence with Bonaruti; and after a tour in the art galleries of Italy, at Berlin, with Kiss, with whom he remained for four years. On returning to Richmond Valentine produced portrait busts of Beauregard, J. E. B. Stuart, "Stonewall" Jackson, and other Confederate celebrities. His *Lee Recumbent* (see SCULPTURE) was executed for the mausoleum attached to the chapel of Washington and Lee University. Valentine had already spent some time at Lexington, Va., modelling a bust of Gen. Lee, and was thus well fitted for the later task. He has also produced several ideal figures and groups, the most noted being *Andromache* and *Astyanax*. His bronze heroic statue of John C. Breckinridge, ordered by the State of Kentucky, was erected at Lexington, Ky., in November, 1887. His latest work is a statue of "Stonewall Jackson" for the Jackson Memorial Association.

VALLANDIGHAM, CLEMENT LAIRD (1820-1871), politician, was born at New Lisbon, Ohio, July 29, 1820, of a Dutch family long settled in Virginia. The name was originally Van Landeghem. His mother's Scotch-Irish blood also entered into his tenacious combativeness. After teaching school two years in Maryland and acquiring the art of stump-speaking, he became a lawyer at Columbus, Ohio, 1842, was sent to the Legislature 1845-47, edited the *Western Empire* at Dayton 1848-50, and was an unsuccessful candidate for several offices. Of unblemished private character and untiring industry and energy, his extreme Southern opinions long excluded him from public life; but after repeated efforts he in 1857 secured a seat in Congress. He always professed to be for the Union, but he was the most resolute, persistent, and annoying opponent of war measures in the North—the model and leader of such as were called Copperheads. The House heard a resolution to inquire concerning his loyalty, Feb. 19, 1862, and received seven petitions for his expulsion. He was in constant anticipation of public punishment or private violence, but nothing short of imprisonment or death could silence him. The same zeal and courage, exerted on behalf of the North, would have won him a high place in national history. When his last term in Congress had ended he kept up his agitation by frequent speeches in Ohio. Anywhere but in the United States he would have been suppressed at once. For a speech at Mt. Vernon, May 1, 1863, he was arrested May 5, by order of Gen. Burnside, commanding the department of the Ohio, tried by court-martial, and sentenced to be confined in Fort Warren, Boston harbor. Pres. Lincoln, who, perhaps, preferred to make his foe ridiculous, commuted this to deportation beyond the lines. Vallandigham was escorted to the Confederate troops in Kentucky. His friends protested, and Lincoln justified the banishment of one who was striving "to prevent the raising of troops, to encourage desertions from the army, and to leave the rebellion without an adequate military force to suppress it." The exile made his way to Canada, was nominated for governor of Ohio in his absence by the Democrats, and defeated by an enormous majority. He returned home in June, 1864, and was not further disturbed, for the tide of war had turned and he was no longer dangerous. His death at Lebanon, O., June 17, 1871, was highly sensational. He was arguing a murder case in court, and in attempting to illustrate the tragedy another was produced by the explosion of a pistol in his hand. His *Speeches, Arguments, Addresses, and Letters*, with a sketch of his life, was published in 1864 as an extended campaign document.

VAMBERY, ARMINIUS, a Hungarian explorer of Central Asia, was born at Duna-Szerdahely, on an island in the Danube, 1832. He was educated March 19, at Presburg and Vienna, and was a private teacher at Pesth when the revolution of 1848 broke out, and naturally joined in the movement. At the siege of Comorn his leg was broken, but this fact probably saved his life when the Austrians became masters of the place. He was, however, exiled and took refuge at Constantinople. Here he improved his opportunities to become acquainted with the Asiatic languages, and finally he determined to visit the native land of the Huns. First he spent nearly two years in the Ottoman embassy at Teheran, then adopting the disguise of a dervish he joined a band of pilgrims on their way to Turkestan. He visited Khiva, Bokhara, and Samarcand without detection, and on his return to Europe brought with him a genuine dervish whom he had deceived by a pretence of visiting Mecca. His contributions to ethnographic and geographical science were warmly welcomed by the learned societies of Europe. His book, *Travels and Adventures in Central Asia* (London, 1864), was issued in several languages. His later books have regard to the same general theme. They include

Wanderings and Adventures in Persia (1867); *Sketches of Central Asia* (1868); *History of Bukhara* (1873); *Mohammedanism in the Nineteenth Century* (1875); *Manners and Customs in Oriental Countries* (1876); *Primitive Civilization of the Turco-Tartar Peoples* (1879). He has published a *Dictionary of the Turco-Tartar Languages* (1878) and an autobiography, *Life and Adventures* (1883). His recent works are *The Origin of the Magyars* (1882); *The Turkish Tribes* (1885); *The Coming Struggle for India* (1886). He has also translated *The Scheibaniade*, an epic poem of the Usbeks (1885).

VANDERBILT, CORNELIUS (1794-1877), capitalist, was born near the site of Stapleton, Staten Island, N. Y., May 27, 1794. His condition was humble, and education he neither possessed nor valued; but his financial talent has never been surpassed. At sixteen he bought a boat to carry farm products to New York; at twenty-three he had amassed \$10,000. Then he became captain of a steamboat plying between New York and New Brunswick, where his wife aided him by keeping a hotel. He remained in the service of Thomas Gibbons till 1829 on a salary of \$1000, and raised the business to \$40,000 a year; then, refusing his employer's offers, he embarked in the building of steamboats to run on the Hudson, Long Island Sound, and elsewhere; hence his title of "Commodore." His enterprise, daring, and persistence were rewarded by uniform success. He was unmerciful to competitors, but he was true to his word and had a rough sense of honor. About 1848 he began to extend his maritime operations. In 1851 he started a line of vessels to San Francisco by way of the Isthmus, with a branch to New Orleans in 1852. The next year he took his family abroad in one of his ships, and in his absence was dropped from the management of the California routes. For this, as in other cases, his vengeance was prompt and effective. He built a rival line, which compelled the other to come to terms. He also established a line to Havre, which was given up at the outbreak of the civil war. His first and chief act of generosity was in presenting to the government the "Vanderbilt," which had cost \$800,000. At seventy his gains amounted to forty millions, much of which was invested in railroads. On these he now concentrated his activities, acquiring control of the Harlem. His only mistake (which he ascribed to bad advice of others) lay in attempting to gain command of the Erie, of which Fisk and Gould were ready to issue as many shares as he chose to buy. He established the New York Central system, and by means of its additions was the originator of trunk lines in the United States. After 1873 he managed 2000 miles of track. His statue, with emblematic surroundings, was erected over the Hudson River Railroad station in New York, 1869. Fast horses and whist were his recreations, money-making his business and delight; but he helped those whom he liked, and in his later years gave \$700,000 to Vanderbilt University at Nashville and presented a church to Dr. C. F. Deems. He died at New York, Jan. 4, 1877, worth nearly a hundred millions. See *The Vanderbilts: the Story of their Fortune*, by W. A. Croffut (1886).

His son, WILLIAM HENRY VANDERBILT (1821-1885), was born at New Brunswick, N. J., May 8, 1821. His father, who had little faith in his abilities, left him to make his own way and gave him no assistance till satisfied that he could do it. This he proved as a bank clerk, and then on a farm in Staten Island, where also he was for a time receiver of a railroad. He was never permitted to take any part in the "Commodore's" vast enterprises till 1864, when he was associated in the management of the Harlem Railroad. He soon won the paternal confidence and showed himself entirely able to carry on what his father had begun, as well as to hold what he had acquired. He became vice-president of the Hudson River Railroad in 1872, and five years later was his father's chief heir and sole

successor in the railway management. Better educated and a less striking and original personality, he filled scarcely less space in the public eye by reason of his roads and his millions. He inherited the taste for horses and added one for collecting pictures. His only notable benefaction was the gift of \$500,000 to the New York College of Physicians and Surgeons in 1884. He died suddenly at home, Dec. 8, 1885, having doubled his father's huge accumulations. The stocks passed into the control and chiefly into the possession of his sons, Cornelius and William Kissam. The former, who had the early discipline of self-help, is the chief manager, and noted not only for business habits and capacity but for blameless life and active interest in religious and charitable work. He erected, 1887, in New York a fine building for the benefit and convenience of his railway employés. (F. M. B.)

VAN DYCK, CORNELIUS VAN ALEN, missionary, was born at Kinderhook, N. Y., Aug. 13, 1818. He graduated at Jefferson Medical College, Philadelphia, and was sent by the American Board of Foreign Missions to Syria in 1840. He was ordained by the members of the Syrian mission in 1846, and in 1848 was made principal of the missionary seminary. In 1857, on the death of Rev. Dr. Eli Smith, Dr. Van Dyck took charge of the mission press and also of the translation of the Bible into Arabic. On his visit to New York to superintend the printing of this work by the American Bible Society in 1866-67, Dr. Van Dyck taught Hebrew in the Union Theological Seminary. After his return to Beirut he resumed his duties in connection with the mission press and was also physician to St. John's Hospital and professor of pathology in the Syrian Protestant College until 1882. He has since been physician to St. George's hospital. He has edited in Arabic several mathematical and physical textbooks, and also translated the *Westminster Shorter Catechism*, *Schönberg-Cotta Family*, and treatises of various kinds.

VAN RENSSELAER, STEPHEN (1764-1839), the "Patroon," was born in New York, Nov. 1, 1764. He was fifth in descent from Kiliaen Van Rensselaer, a jewel merchant of Amsterdam, who under authority of the Dutch West India Company acquired in 1630-7 an estate of more than 700,000 acres on the Hudson: this was occupied by the family and by their numerous tenants under a peculiar feudal tenure, and confirmed by various orders during the Dutch possession, and by a grant of Gov. Dongan in 1685. Stephen inherited seigniorial rights over some 3060 farms in Albany and Rensselaer counties, including some 436,000 acres; these lands he did much to improve and settle, but would never sell. His mother was a Livingston; and after graduating at Harvard in 1782 he married a daughter of Gen. Philip Schuyler. Throughout life he was active in the service of the State, and held many offices, being in the Assembly 1789, in the New York Senate 1790-5, lieutenant-governor 1795-1801, president of the Constitutional Convention, regent of the State University from 1819, and for a time its chancellor, in Congress 1823-9. In the war of 1812 he commanded the State militia and directed the attack on Queenstown. He took an early and active interest in the Erie Canal, was one of the commissioners from 1816, and for several years president of the board. He directed Eaton's geological surveys, 1821-3, and bore the cost. He will be long remembered as the founder (1824) of the Rensselaer Polytechnic Institute at Troy. To have exercised equal public spirit concerning the disputed and undetermined rights of the tenants on his huge property would have saved the State much trouble and some bloodshed.

The "patroon" system, under which extensive portions of New York had been settled, in which his family had the largest interest, had been advantageous at first, but its evils had been pointed out in 1732, and it was ill adapted to the nineteenth century and to

republican institutions. The tenants through long occupancy had come to regard themselves as practically owners of the soil, and the antique though slight annual payments were felt as burdensome. In case of transfer, one-fourth of the price was claimed by the patron; special objection was made to these "quarter sales," and their legality questioned. The last possessor of these feudal rights had been careless or lenient in collecting his rents, often allowing them to run on from year to year, till a sum of about \$400,000 was due him. The tenants expected these amounts to be remitted, but he died at Albany, Jan. 26, 1839, without making any such provision. Then the trouble began. Mass-meetings were held in the country, and an accommodation sought in vain; the heirs resorted to writs of ejection, which were resisted. The sheriff with a large posse was confronted at Reidsville, Dec. 2, 1839, by a throng estimated at 1500. Gov. Seward in a message of Jan. 7, 1840, denounced the tenures as "odious," and in May a bill was passed to settle the difficulties, but without result. The agitation continued; anti-rent associations were formed, and outrages committed by bands of pretended "Indians." The trouble spread to other parts of the State, where the same system existed. Several lives were lost, disorder prevailed, and Delaware county was declared to be in insurrection; many persons were arrested and 22 sentenced to terms of imprisonment. The anti-renters became a strong political party, and contributed to the election of Gov. Young, after making Silas Wright's term a period of embarrassment and alarm. The disturbance lasted for seven years, and constitutional conventions, legislatures, and courts had much to do before the lease-hold system was finally abolished. Van Rensselaer's heirs modified their claims, and parted with much of their land. These events supplied a motive to three of Cooper's novels, *Satanstoe*, *The Chain-bearer*, and *The Redskins*, and to a satiric poem, *Hildenburger* (1855); all these take the side of conservatism and privilege. See E. P. Cheyney's *Anti-rent Agitation* (1887), in the publications of the University of Pennsylvania. Several of the patron's uncles and cousins rendered service and won military distinction in or since the Revolution; one of his sons attained note as a Presbyterian clergyman, and another as an officer in the civil war.

VASSAR COLLEGE, the first well-equipped institution for the higher education of women, is located 2 miles east of Poughkeepsie, N. Y. It was founded by Matthew Vassar, an Englishman, who came to America in 1796. Mr. Vassar's earnest desire to use his wealth for the public good led him to consider favorably the suggestion of his niece, Miss Booth, that a model school for young women should be established, and the bolder proposition of his friend, Milo P. Jewett, that he should found and endow a college for young women which should rank with the leading colleges for men. After about two years of preliminary work the college was incorporated Jan. 18, 1861, under the name of "Vassar Female College," which title was, in 1867, changed by the Legislature, in accordance with the request of the founder, to "Vassar College." The charter empowered the 29 trustees to have control of the property, to appoint the members of the faculty, and to confer degrees. At the first meeting of the board of trustees, Feb. 26, 1861, Mr. Vassar transferred to that body property valued at \$400,000, including a farm of 200 acres, on which the college was to be built. This gift was afterwards increased by large sums for various purposes during Mr. Vassar's lifetime. At his death he bequeathed more than \$250,000 for the establishing of four funds, viz.: auxiliary, library, art and cabinet, and general repair. At his first interview with the board Mr. Vassar showed keen foresight and great breadth of view in the remarkable speech in which he set forth his hopes concerning the college and his ideas in regard to the education of women. He also stamped the religious

character of the college in saying that all sectarian influences should be carefully excluded, but the "training of our students should never be entrusted to the skeptical, the irreligious, or the immoral."

In 1861 Milo P. Jewett was chosen as the first president. After his resignation in 1864 John H. Raymond was elected. He retained the position until his death in August, 1878. Samuel L. Caldwell, who succeeded him, resigned in 1885. After one year, during which James Ryland Kendrick served as acting president, James M. Taylor accepted the position, which he still holds (1889).

The main building and observatory were completed in June, and it was decided to open the college on Sept. 20, 1865. More than three hundred students presented themselves for admission, some of whom, in anticipation of this opening, had been carefully prepared for college work. The first faculty consisted of the president, lady principal, 8 professors, and 20 assistant teachers. In accordance with the wish of the founder, that men and women should co-operate in the instruction and discipline of the college, three of the professors and all of the assistants were women. In the present faculty six professors and all of the assistant teachers are women.

The college buildings are as follows: Main building (erected 1865), observatory (1865), museum (1866), laboratory (1886), conservatory (1886), gate-lodge, gas-works, boiler- and pump-houses, and farm-buildings. The main edifice was originally 500 feet long and 164 feet broad at the centre, but in 1872 this breadth was increased to 200 feet. The building is constructed of red brick with trimmings of blue free-stone. The central part and the wings are five stories in height (94 feet), while the connecting portions are four. This building contains apartments for the president and other resident officers and for 300 students, rooms for lectures and recitations, a chapel, library, reading-room, offices, parlors, dining-hall, and kitchen. There is a steam-elevator in the centre of the building. As protection against fire the partition walls are all made of brick and extend from the ground to the top of the house, and the long corridors may be quickly divided into five separate parts by means of sliding iron doors connected with fire-proof walls. Ample protection is further afforded by means of a steam-fire-engine and similar appliances.

The library contains about 16,000 volumes. It is a large, well-lighted room, which is open to the students during ten hours of each day. The library fund provides for an annual increase in the number of books. The observatory is located on a slight elevation, a short distance from the college building, and consists of a basement, principal story, and dome. The equatorial telescope has an object-glass 12½ inches in diameter. The observatory contains also a meridian circle with collimating telescopes, clock, and chronograph, portable telescopes, and apparatus for making solar photographs. The gymnasium contained originally rooms for calisthenics, the riding-school, and a bowling-alley; also a society hall and music rooms. In 1872 the riding-school was discontinued, and the gymnasium was remodelled so as to afford suitable accommodation for the departments of natural history and of art. The valuable collections belonging to these departments were then transferred from the main building to the larger rooms in the building now known as the museum. The gymnasium is well equipped with the apparatus used in the Sargent system, and the alumni have raised a fund for the immediate erection of a new building. The Vassar Brothers' Laboratory of Chemistry and Physics was the gift of Matthew Vassar, Jr., and John Guy Vassar, nephews of the founder. It was erected in 1880 and supplied with all modern appliances for the study of physics and chemistry. In 1886 the Eleanor Conservatory, a memorial gift, was added to the college buildings for the use of the botanical department.

The grounds embrace about 210 acres and form a beautiful park in which the students may indulge in various forms of recreation. A lake affords facilities for boating and skating.

A preparatory department, maintained from the opening of the college until 1888, was then discontinued by vote of the trustees. The departments of painting and music were in 1878 changed into schools of painting and music, which have their respective courses of study leading to diplomas. Resident pupils in music or painting are members of the college family and are required to give a portion of their time to collegiate study. Each school has a director, who, together with the president of the college, has entire control of his department.

In the regular course for the degree of A. B. the studies are all prescribed to the middle of the sophomore year and languages to the close of the same year. During the junior and senior years each student submits for the approval of the faculty an election of from 13 to 15 recitation hours per week. Special courses designed chiefly for teachers may be pursued. For admission to these courses the requirements are in general the same as for admission to the regular course, viz., examinations similar to those required for entrance to the leading colleges of the country. To obtain the degree of A. M. or of Ph. D. the candidate must pursue a course of non-professional study approved by the faculty, and must present a satisfactory thesis upon some topic of the work. Seven hundred and sixty-nine young women have received the degree of A. B. and 29 that of A. M. The first honorary degree, LL. D., was given in 1887.

The charge for one year, including tuition, board, and laundry work, is \$400. In addition to the \$100,000 given as an auxiliary fund, there are eight scholarships, yielding \$300 or \$400 annually. These funds are for students in the regular course.

(J. M. T.)

VAUGHAN, CHARLES JOHN, English clergyman, was born at Leicester, Aug. 6, 1816. He was educated at Trinity College, Cambridge, and graduated B. A. in 1838, and M. A. in 1841, and was fellow of his college from 1839 to 1842. Having taken orders he became vicar at Leicester in 1841, and in 1844 was made head master of Harrow School, which position he held fifteen years. In 1860 he was made vicar of Doncaster and rural dean and chancellor of York Cathedral. In 1869 he was made master of the Temple, London, and in 1879 dean of Llandaff. He was a member of the Cambridge University Commission 1858-62, and of the English New Testament Revision Company until the close of its labors in 1881. He has been noted as a preacher, and several volumes of his sermons have been published. Among these are *Memorials of Harrow Sundays* (1859); *Revelation of St. John* (1863); *Church of the First Days* (3 vols., 1863-65); *Authorized or Revised?* (1882); *Philippians* (1885).

VEDDER, ELIHU, artist, was born in New York, Feb. 26, 1836, and had his first art instruction in his native city. Later on he studied also with T. H. Matteson, and under Picot in Paris. For a time he had a studio in New York, but he subsequently removed to Italy, where he has since resided. His works are characterized by fertility of imagination, and broad and vigorous handling. Ideal in motive, they show the desire of the artist to give expression to his emotions and thoughts, and have given rise to much discussion as to their intent and meaning. His more important paintings include *The Lair of the Sea-Serpent*; *Arab Listening to the Great Sphinx*; *The Crucifixion*; *The Lost Mind*; *Roc's Egg*; *Young Marsyas*; and *Cumean Sibyl*. He has also designed a series of strong and original illustrations for Omar Khayyam's *Rubaiyat*. He was elected an associate of the National Academy, N. Y., in 1863, and an academican two years later.

VENTILATION AND WARMING.

Ventilation consists in changing the air any-
See Vol. XXIV, p. 157 (p. 165 Am. Rep.).
where, whether it be in an enclosed space or an open field, but is generally understood to mean the substitution

of pure air for foul air in dwellings, public buildings, hospitals, factories, ships, cars, mines, etc.; in short, wherever man or beast is liable to reinhale his own or others' breath. Formerly the openings of doors, windows, crevices, and chimneys were deemed sufficient (if the subject was thought of, which is doubtful), and it was also supposed that a cold room was a healthy one. In modern times mechanical ventilation by means of fan-wheels was first introduced in cotton-factories, and the improved health of the operatives drew attention to the necessity of pure air in the habitation of man. Although scientists and doctors had long believed and asserted that deleterious gases vitiated the air and made it injurious to human life, and fires were built in the public streets in those days for the purpose of destroying these gases, it is only within recent years that the scientific study of ventilation and its practical application have been deemed of sufficient importance to be incorporated in the plans and specifications of architects and builders. Without entering into the discussion of the chemical constituents of the atmosphere (see **ATMOSPHERE** in the **ENCYCLOPEDIA BRITANNICA**) it may be stated that one cubic foot of pure air per second is what should be allowed every individual, though half that amount is all that is absolutely necessary, and in order that he may not reinhale it a change of air is indispensable, and must be maintained without giving the sensation of an unpleasant draught—say at the rate of one and not to exceed three feet per second.

Warming is the twin problem with *Ventilation*, and the two will be considered together, as they are almost inseparable. In order to properly ventilate and warm a room in winter or keep it fresh or cool in summer, it is of course necessary to remove the vitiated or foul air in the same quantity as the pure air is introduced—they should be simultaneous and interdependent, otherwise there is imperfect ventilation. The problem is how to accomplish this double or reciprocal movement of air without creating unpleasant draughts, and at the same time securing an equable temperature (say, 70° more or less) throughout the room. It is a well-known fact that heated air rises to the ceiling, while cold air, the emanations from the breath and body, the products of combustion, bad odors, etc., are found near the floor; this being the case, it would seem the most natural thing in the world to withdraw the impure air at the point where it is found, the floor, and let the pure air in at or near the ceiling, as the vacuum created by withdrawing the foul air would cause the warm air to descend gradually to the floor.

Ventilation may be either *natural* or *artificial*; the former is divided into (1) Diffusion, (2) Action of the winds or perflation, and (3) Movements made by unequal weights of air. Every gas diffuses inversely as the square root of its density, and rooms are partially ventilated on this principle through crevices and imperfect carpentry, and even through brick and stone walls (Parke). The action of the winds or perflation is uncertain and difficult to regulate—opening windows at top and bottom, inserting slanting boards to direct the wind upward, or special openings made at various points, ventilating tubes with cowls, etc., have all been tried with indifferent success. Movements made by unequal weights of air are more satisfactory—the fire-place and chimney afford a good illustration of this kind of natural ventilation; also the furnace with registers and outlet tubes properly placed; but this partakes of *artificial ventilation*, which will now be considered. This may be divided into plenum or forced ventilation (propulsion) and vacuum or aspiration (extraction). There is much diversity of opinion as to the relative merits of these two kinds of

ventilation, and in some instances they are combined, hot (or cold) pure air being forced in and foul air extracted at the same time. Scientifically considered, one would think that the great elasticity of the air would be an objection to propulsion for the reason that a room could be surcharged with air without necessarily changing it as rapidly as it entered; while on the other hand, by aspiration, it would change at the same rate as it was extracted, on the principle that "nature abhors a vacuum." Theories in ventilation and warming are as numerous as trees in a forest, and it is only by practical tests and experiments that the question can be settled.

The question of "up-draft" or "down-draft" is equally disussed by engineers and sanitarians, and opinion is divided as to which of the two systems is the best. In the first, the extraction of foul air is made from the top of the room, and in the other from the bottom of the room. The former is the system that has been employed in the Halls of Congress for over a quarter of a century, while the latter is coming into more general use in public buildings in recent years.

The change of air necessary to constitute perfect ventilation and warming depends upon the size of the room and number of its occupants. As has already been stated, each individual should be supplied with fresh air at the rate of one cubic foot per second, and to prevent the unpleasant sensation of a draught the movement of air should not exceed 3 feet per second; better if but 1 or $1\frac{1}{2}$ per second. It will be observed that the inlets and exits to the room must bear a certain proportion to its size and the velocity of the air's movements; it then becomes a mere matter of mathematics to determine the question of how much air is needed and how frequently it must be changed. Parke says "it may be fairly assumed that the quantity of air supplied to every inhabited room should be great enough to remove all sensible impurity, so that a person coming in from the external air should perceive no trace of odor or difference between the room and the outside air in point of freshness. Taking the carbonic acid as the index of impurity it appears from experiments made by Dr. De Chaumont and myself that the organic impurity of the air is not perceptible to the senses until the carbonic acid (*i. e.*, the initial and respiratory carbonic acid) rises to the ratio of .6 per 1000 volumes, or .0006 to each cubic foot. Occasionally air may seem pure to the senses when the carbonic acid is .7 or even .8 per 1000 volumes, but the usual rule seems to be when it exceeds .6 the air commences to become perceptibly impure. When the carbonic acid reaches .9 or 1 per 1000 volumes, the air is what is called close and fusty; above this it becomes disagreeable."

How to warm as well as ventilate a room is a question of importance to a large section of our diversified country. Heating without ventilation is no longer deemed prudent, and the best means to accomplish this double purpose is one that is still *sub judice*. The fire-place or grate, the stove of many patterns, the furnaces without number, the steam-pipes or coils, hot-water pipes, radiators, and what not, are to be found everywhere, while the manner of introducing heated air into large rooms and public buildings, even after the kind of apparatus for heating them has been fixed upon, is no easy question to decide. Shall the heat be admitted at the floor and the foul air extracted at the ceiling, or *vice versa*? shall it be forced in (plenum), or shall it be drawn in (vacuum)?—if propulsion is used, a fan-wheel is necessary; if suction is preferred, a heated ventilating shaft, or a fan-wheel (perhaps both), will be required; while a combination of plenum and vacuum will certainly necessitate fan-wheels for each. Then the condition of the outside air has to be considered, whether cold or warm, moist or dry, high wind or moderate, and the point of the compass from which it comes; the

location of the building itself may influence the heating and ventilating of its rooms, while the light employed (candle, gas, or electric) must also receive attention, so that no system can be said to be perfect, however satisfactory it may be under favorable conditions.

The *open fire*, which most closely resembles the sun's heat by direct radiation (and is doubtless the most healthful), may answer for warming and ventilating small rooms, the demands for combustion preventing the air from becoming stagnant and keeping it in constant motion towards the fire-place; but this very movement of air creates a sensation of discomfort, as a draught from the colder portions of the room or from the cracks and crevices around the doors and windows chills the feet and backs of those sitting in front of the fire, for it must be remembered that the air itself is not warmed by the fire. By supplementing the open fire with warmed air from other sources (small furnaces, etc.), or admitting the cold air back of the fire-place, where it is warmed and delivered into the room (radiating grates), the discomfort spoken of may be in great measure obviated.

The *stove* is probably the most economical and most generally used means for warming small dwellings and, when properly made, and set with a view to ventilation, is, next to the fire-place, the most healthful. There are thousands of different patterns of stoves—from the "thermometer stove" of Dr. Arnott, invented in 1838, and the original "Franklin stove" of earlier date, to the styles of the present day. Whatever pattern is used the following points must be considered: The stove should have a large heating surface, and be encased, except at the top, to prevent direct radiation—the object being to heat the air coming into the room and not the persons immediately around it. A fresh air duct from the external atmosphere delivering the pure air inside the casing surrounding the stove will give an equal temperature throughout the room, while the under-draft to the stove will ordinarily remove the foul air by suction, though it is better to have an opening on a level with the floor, connecting with a heated ventilating shaft. An urn or other vessel filled with water should be kept on top of the stove. When the gas is lighted or the room becomes too warm another opening (fitted with a register) near the ceiling and connecting with the heated shaft may be opened occasionally. It must be remembered that the temperature of a room is no index to the purity of the air.

Steam heating is now largely used in public buildings, hotels, offices, and in not a few private residences, and if proper ventilation and indirect radiation is combined with it, no serious objection can be urged against it, or against *hot water heating* (meaning thereby the heat radiated by pipes or coils in the rooms and halls of buildings, and not heating from such pipes placed in basements and conducted through flues to the rooms above). In such cases fresh air from the outside may be delivered among the coils, thus securing indirect with direct radiation, or admitted at the top of the room, care being taken that foul air ducts from openings level with the floor be connected with a warm ventilating shaft. The disagreeable noises resulting from turning the steam into partially heated or cold coils is said to be now obviated by the use of but one set of pipes, the condensed steam (water) returning alongside the steam from the boiler; of course this also does away with the extra valve and drip-cock at the distal end of the set of coils.

Heated air supplied by either furnaces, steam-coils, or hot water pipes located in the basement, is a very common plan for heating fashionable dwellings, large buildings, churches, school-houses, theatres, etc., the heated air being conveyed through ducts built for that purpose, and delivered where wanted. The general plan of such furnaces, coils, and pipes may be briefly stated as follows: The object being to obtain as large

heating surface as possible in order that the cold air introduced may become sufficiently warmed before passing into the various parts of the building, a furnace should be built upon the same principle as a tubular boiler and enclosed to prevent the escape of the air which is being warmed and collected in the dome, sufficient space being allowed between the enclosing walls and the furnace to permit the warming of a certain amount of air introduced from without. Steam-coils and hot water pipes are also arranged to secure the greatest amount of heating surface possible, and similarly enclosed. Small portable furnaces, such as are found in ordinary dwelling-houses, are enclosed by sheet-iron instead of brick, the cold air entering from the bottom and becoming warmed as it passes upward into the drum.

The hot air is now ready to be conducted into the room or hall: the question is, where shall it enter? The consensus of opinion now is, that it should be admitted at or near the floor, for reasons already given. Shall it be drawn in by vacuum, or forced in by propulsion, or shall both aspiration and plenum be employed? If by vacuum, where shall that be applied, near the ceiling or at the floor? As before stated, the Halls of Congress are heated and ventilated by plenum, the heated air in winter and the fresh air in summer being forced in by means of a large fan-wheel, through numerous openings in the floors, carrying with it the dust and other impurities which naturally gather there, while louvers or ridge ventilators are placed at or near the roof. It is claimed, too, that the floor registers are used as cuspidors, and that the general sanitary conditions of the halls is detrimental to health on account of the system of heating and ventilation employed. The more recent and scientific application of the forces of nature as developed by the *vacuum* or *down-draft system* may be here explained: A vacuum is created in a heated shaft outside the building; the rooms or halls to be ventilated are connected with this shaft by numerous ducts opening upon the floor, the number and size of the openings depending on the air space to be ventilated; at or near the ceiling fresh air is admitted through numerous openings and in the same proportion as it is withdrawn below; this in summer or moderate weather. In winter the heated air is admitted near the floor, naturally ascends, and (the openings in the ceilings being closed) distributes itself equally throughout the room and finds its exit at last through the foul air duct openings at the floor. Objection is made that heated air will remain at the top of the room: theoretically it will; but experiments have proved that it does not, when a vacuum is created below; on the contrary it is discharged as rapidly as it enters, but not till after it has become equally diffused throughout the room, the thermometer marking but two or three degrees difference between the top and the bottom of the room. In fact, the expansion of air by heat is only $\frac{1}{100}$ of its volume for every degree (F.) of additional temperature; if it is zero outside and 70° inside, the air in the room will be only one-seventh lighter than the outside air. By placing the ventilating shaft and chimney side by side (carrying them both well up above the building) the former will be sufficiently heated for ventilating purposes in ordinary weather, but on damp mucky days, or in summer, when the chimney is not heated by fire, a small furnace is necessary to create a vacuum in the shaft. An exhaust-fan is substituted for the ventilating shaft, when desired, and acts on the same principle, by creating a vacuum upon the floor of the room which the warm air above at once fills. Both propulsion and vacuum are employed in mines, aboard ships, and for inaccessible spaces.

Pure Air.—The question of obtaining pure air for heating and ventilating purposes is much discussed, many believing that it cannot be had at the level of the lot or street upon which the house is built, and pure air shafts of various heights have been suggested.

Others claim that smoke, cinders, and the products of combustion in a large city would be drawn into shafts and that the air circulating upon the surface of the earth is best. All agree, however, that air from cellars, damp basements, newly made earth, foul streets, or marshy grounds is not fit to use. This question must be settled by the circumstances involved in each case.

The system of ventilating and warming introduced by Gouge of New York, based on the increased force air gains by being gathered into different sized tubes, partially inserted one into the other, and started by means of a gas jet or lamp, is novel and said to be very satisfactory, particularly in large buildings and railroad cars, where it has been pretty extensively adopted.

The Ruttan-Smead system is fast becoming very popular, many school-houses and public buildings being heated and ventilated by it. The principle is the down-draft or vacuum system, with the additional advantage of utilizing the heated air after it has left the rooms or halls by its passing through numerous openings under the floors, thus keeping them warm, and being again collected in a "gathering-room," where it is further used for ventilating the privies and urinals located in the basement, it thence passes into the heated ventilating shaft. The furnace is tubular, and so constructed as to not only secure a large heating surface but also obtain much heat from the gases and smoke before they escape into the chimney. The ventilating shaft and chimney are carried well above the building and are separated by a thin partition which keeps the shaft heated when the furnace is in use, and a small furnace supplies heat when it is not in use or on damp or rainy days. Each room is supplied with a separate fresh air duct entering near the floor, which is so arranged as to let in either warmed air or cold air, or a mixture of both, as may be desired. An examination by the writer of the "gathering-room" and the privies of a twelve-room school-house with 480 scholars demonstrated the practicability of thoroughly deodorizing and drying the deposits, an accumulation of two years from this number of pupils giving off no odor and appearing like a few barrows of dark dry earth, the urine and all moisture having evaporated. The down draft through the privy holes was very strong and constant, and no odors were perceptible.

No other new systems of ventilation and warming have been introduced in late years; perhaps there are none that do not embrace one or more of those already described. (P. II. B.)

VERDI, GIUSEPPE, the foremost of modern Italian composers, was born at Roncolo, near Parma, Italy, Oct. 9, 1814, his father being a poor inn-keeper. From his earliest years he manifested a talent for music, and at the age of eight began to receive lessons from the village organist, while also attending a day-school at Busseto. At his eleventh year a liberal amateur of that town received him into his house and put him under the organist of that place, where he already began to write little orchestra-pieces. In 1833, through the bounty of his patron, he was able to go to Milan, and received for three years instruction from Lavigna, maestro in the great theatre, La Scala. Thence he returned to Busseto, and in 1839 married the daughter of his benefactor. Then taking up his residence in Milan, he brought out his first opera, *Conte di San Bonifazio*, at La Scala. Such was its success that he forthwith received a commission from the director for three other operas, to be produced in two years. The first he presented was a comic opera, *Un giorno di regno*, which met with but a cool reception, and this, coupled with the death of his dearly loved wife, determined him to renounce comic opera forever. His next work, *Nabucodonosor*, was performed at La Scala with triumphant success during the carnival of 1842. From that hour the young master took rank among the first composers of the age. His *I Lombardi* appeared at the same theatre in 1843, and his *Ernani* at Venice,

1844. In the succeeding years he produced a series of operas in the same style: *I due Foscari*, *Giovanni d'Arco*, *Alzira*, *Attila*, *Macbeth*, *I Masnadieri*, *Jerusalem*, *Il Corsaro*, *La battaglia di Legnano* (interdicted at Rome after its first representation in 1848), *Luisa Miller*, *Stiffolia*. The *Macbeth* on its representation at Florence in 1847 was received with such enthusiasm that it led to his being called to London, where he presented his *Masnadieri*, of which the principal role was written for Jenny Lind. This year also his *Jerusalem* was performed with great success at Paris. Deeper yet in impressiveness and showing greater power in characterization are his *Rigoletto* (1851), *Il Trovatore*, his chief d'œuvre (1852), *La Traviata* (1853), *I Vespri Siciliani*, (1855) *Simone Boccanegra* (1857). His other works of this class are *Alerlo* (1857), *Un ballo in Maschera* (similar to Auber's *Masked Ball*), *La forza del Destino* (brought out at St. Petersburg in 1863 and held by some to be his highest achievement), *Don Carlos* (1866), *Aida* (1871), and *Montezuma* (1878). His last work, *Otello*, founded on Shakespeare's tragedy, was produced at La Scala, Milan, in February, 1887, with great enthusiasm. Besides operas Verdi wrote a series of church and chamber pieces, the best known of which probably are *Romanzi*, a hymn for the second London Exhibition in 1862, and a *Requiem Mass* for the funeral of Alessandro Manzoni in 1874. In place of the amorous, sentimental, and brilliant music of Bellini, Rossini, and others, Verdi has sought to substitute work of a manlier type, characterized by energy and grandeur. During the Austrian rule in Italy he responded to the aspirations of his compatriots after liberty and gave musical expression to them, so that his name ("Viva Verdi") became their rallying-cry. In his later years he has lived with his second wife, Giuseppina Strepponi, a noted singer, in Genoa, and at his villa near Busseto, where he occupies himself with agriculture. In 1859 he was elected a member of the national assembly of Parma; in 1861 he became a member of the Italian chamber of deputies; in 1874 he was named by Victor Emmanuel a member of the senate. In 1859 he was chosen a corresponding member of the Paris Academy of Fine Arts, and in 1864 succeeded Meyerbeer as associate.

VERE, AUBREY DE. See DE VERE.

VERGENNES, CHARLES GRAVIER, COMTE DE (1717-1787), a French statesman, born at Dijon, Dec. 28, 1717, being son of the president of the parliament of Dijon. He early entered the French diplomatic service, and in 1740 accompanied the diplomat, M. de Chavigny, as a member of his staff to the court of Lisbon. In 1750 he was appointed minister at the court of the Elector of Treves, and, from 1755 to 1768, was ambassador to the court of the Sublime Porte. In 1771 he was sent to Sweden and had no small share in the revolution that occurred under Gustavus III. When Louis XVI. came to the French throne in 1774, he immediately recalled Vergennes from service abroad and made him his minister of foreign affairs, which office he filled with all the tact and ability of a skilled diplomatist, having ever before his eyes as his supreme object the interests of his king and country. Among the leading acts of his ministry were the treaty of Soleure, concluded with the Swiss in 1777, the treaty of Teschen with the Emperor Joseph II. in 1779, and the treaty of commerce negotiated with England in 1783. But still more important to Americans was the steady and efficient support lent by him to the United States in their struggle for independence. When disasters befell their arms in 1776 and commissioners were sent to various countries in Europe to seek foreign recognition and aid, he granted, in December, a courteous audience to Franklin, Deane, and Lee, and counselled the king to grant them money from the royal exchequer and permit them to purchase military supplies. In December, 1777, he encouraged Louis to recognize the independence of the States and to enter into a

treaty with them (signed February, 1778), through which they secured the co-operation of French land-forces and war-ships, as well as aid in money and munitions. Later he openly and in defiance of England presented Franklin and his associates at the court of Versailles, shortly after which M. Gerard was sent as minister plenipotentiary to the United States, while Dr. Franklin was received in the same character at the French court. When John Adams arrived in Europe in July, 1781, asking a seat in the congress of ministers about to be held at Vienna to treat of peace between Great Britain and all her enemies, Vergennes insisted on this being conceded him, and on the British refusal to recognize Adams he was instrumental in having the congress abandoned. Finally Comte de Vergennes was a party to the treaty of peace signed at Paris, Sept. 3, 1783, by which American independence was definitively recognized, though in arranging the terms he showed himself fully as favorable to Spain as to the United States. He died at Versailles, Feb. 13, 1787.

VERNE, JULES, French author, was born at Nantes, Feb. 8, 1814. He received his literary education in his native city, had some experience as a sailor, and afterwards studied law in Paris. In 1858 he made his debut in literature with a versified comedy, *Les Pailles Rompues*, and followed it up with a comedy in three acts, *Onze Jours de Siège*, and several comic operas. In 1863 appeared his *Cinq Semaines en Ballon*, a romance in which he weaves the results of modern scientific research into a fantastically imaginative narrative, indulging, at the same time, in adventurous flights of fancy into the region of the possible future of science, especially as relating to geography and astronomy. The immediate success of this production encouraged its author to work this vein and he gave forth an astonishing number of works in which plausible science and romantic exploits were grotesquely blended. Among them are *Les Aventures du Capitaine Hatter*; *Le Voyageur au Centre de la Terre*; *De la Terre à la Lune*; *Les Enfants du Capitaine Grant*; *Vingt Mille Lieux sous les Mers*; *Une Ville Flottante*; *Le Tour du Monde en quatre-vingt Jours*; *Le Pays des Fourrures*; *Le Docteur Ox*; *Michel Stragoff*; *Hector Servadac*; *Les Indes Noires*; *Un Capitaine de Quinze Ans*; *Les Cinq Cent Millions de la Begum*; *Les Tribulations d'un Chinois en Chine*. Most of these have been translated into English and widely popularized in dramatic versions, to which they readily lend themselves. But Verne has not confined himself to romantic fiction. He has compiled and edited *Geographie Illustrée de la France*, and *Histoire générale des grands Voyages et des grand Voyageurs*, the latter being also translated into English.

VERPLANCK, GULIAN CROMMELIN (1786-1870), scholar and statesman, was born in New York, Aug. 6, 1786, of mingled Dutch and Connecticut stock. His father, Daniel C. Verplanck (1761-1834), was a member of Congress, 1803-9; his mother's father was Dr. W. S. Johnson, President of Columbia College. Graduating there in 1801, he studied law and travelled in Europe for several years. Returning, he engaged in State politics, was a candidate of the Malcontents for the Legislature, and entered that body in 1820. His anniversary discourse before the New York Historical Society in 1818 on *Early European Friends of America* attracted much attention. Some satires on DeWitt Clinton were credited to Verplanck. Though a layman he was professor of Christian evidences in the Episcopal General Seminary, and in 1824 published *Essays on the Various Evidences of Revealed Religion*, in which he laid chief stress on internal or moral evidence, rather than the external or historic. His *Doctrine of Contracts* (1825) was praised by Wheaton. From 1825 to 1833 Verplanck was in Congress, where he worked for the extension of copyright, and Poe says that "While in Congress he was noted as the most industrious man in that assembly, and acted as a

walking register or volume of reference, ever at the service of his colleagues." In 1834 he was Whig candidate for mayor and was narrowly defeated. After that he sat for some time in the State Senate, and was active in its judicial functions. In 1833 appeared his *Discourses and Addresses*, and three volumes of *Miscellanies* reprinted from *The Talisman*, which he had conducted with Bryant and R. C. Sands. His reputation was enhanced by college addresses on *The Right Moral Influence and Use of Liberal Studies* at Geneva, 1833, on *The Influence of Moral Causes on Opinion, Science, and Literature*, at Amherst, 1834, and on *The Advantages and Disadvantages of the American Scholar*, at Union, 1836. He issued an annotated edition of Shakespeare (3 vols., 1844-47), but the plates were destroyed in the fire at Harper's, 1851. Verplanck's position in New York may be compared to that of Ticknor in Boston. (See TICKNOR in the *ENCYCLOPEDIA BRITANNICA*.) From 1829 he was vice-chancellor of the University of New York, and from 1846 president of the commissioners of emigration, and writing most of their reports. Much of his later years was spent in his ancestral home at Fishkill. He died in New York March 18, 1870, and Bryant delivered a memorial address before the Historical Society in May following.

VERRAZANO, GIOVANNI (c. 1480-1527), Italian navigator and explorer, is supposed to have been born shortly after 1480 in Florence, Italy, where members of his family had attained high office. He is said to have travelled extensively, particularly in Egypt and Asia, and is even doubtfully reported to have commanded one of Aubert's ships in that mariner's expedition from Dieppe to America in 1508. In 1521 Verrazano appears in history as a French corsair under the name of Juan Florin or Florentin, preying on the commerce of Spain with her new possessions. In particular he is said to have captured in 1522 the rich treasure-ship in which Cortez was sending to Charles V. of Spain the spoils of Mexico, valued at \$1,500,000. While following this occupation he seems to have attracted the notice of Francis I., King of France, under whose auspices he started in 1523 with 4 ships, professedly to reach Cathay by a westward voyage, "expecting to penetrate any intervening land," although it may be questioned whether his real object was not piracy as well as a desire to reach the new regions discovered by Cabot and Cortez—that is, North America. His little fleet encountered violent storms and he was obliged to put back to some port in Brittany with only two vessels, in one of which, the *Dauphine*, he made a fresh start Jan. 17, 1524, from the Island of Madeira, with 50 men. In 50 days he made the land in N. lat. 34°, not far from Cape Fear in North Carolina, and began his search for a harbor by coasting 50 leagues to the south. Failing in this object, he turned along the shore northward, and while at anchor (perhaps near Raleigh Bay) sent a boat ashore for water and found the natives (whom he describes as black, of moderate stature and good proportions, and naked save for a breech-cloth) friendly and hospitable. Still following the shore, in fifty leagues he reached a pleasant place where he anchored, and found the natives fairer than those first seen and the country as fertile but colder. Hence his crew carried off a boy and brought him with them to France. After coursing a hundred leagues farther to the north-east, he arrived at a spot between small steep hills where a great stream poured its waters into the sea. Anchoring in the river, Verrazano sent his boat in, and this, after going half a league, found that the entrance widened into a lake of three leagues circuit, upon which at least 30 native boats were passing from shore to shore. A sudden squall frightened the boatmen and they returned to their ship without further exploring this pleasant harbor, which seems to have been that of New York. Sailing thence east, they then discovered about 10 leagues from the

mainland an island of triangular shape and "about the size of Rhodes," to which they gave the name of Louisa, mother of Francis I. From this island (supposed to be Block Island) Verrazano steered landward and in fifteen leagues came to a most beautiful harbor which he places in the parallel of Rome, 41° 40' N., when the natives in their boats crowded around the ship and showed themselves curious and friendly, being easily persuaded to come aboard. They are described as fine-looking, the handsomest seen on the voyage, of taller stature than Europeans, of light color, sharp faces with long black hair and black eyes, but with a mild expression. In this agreeable harbor, which has been identified as Newport, Verrazano tarried 15 days, and then, through the kindness of the inhabitants having supplied himself with all necessaries, he sailed for 150 leagues farther along the coast, the next landing being made in a country colder, full of thick woods, and where the natives were rude, shy of strangers, and clothed in skins. This landing has been placed not far from Portsmouth, N. H. Continuing the voyage hence, in a north-easterly direction, 52 islands were discovered, all near the shore, but without stopping to examine these Verrazano held on another 150 leagues, when he attained about latitude 50° N. Here, having reached the country already discovered by the adventurous fishermen of Brittany, and finding his stores almost exhausted, he decided to return to France, having, as he says, discovered more than 700 leagues of unknown territory. His arrival at Dieppe is placed early in July, 1524, for his letter to the king giving an account of his discoveries is dated from that port, July 8, 1524. We lose trace of Verrazano after his return from this voyage. It has been suggested that he went to England and offered his services to Henry VIII., and contemporary allusions give color to the suggestion. Biddle, in his *Memoirs of Sebastian Cabot*, suggests he was the Piedmontese pilot who was killed and eaten by the savages in Rut's expedition of 1527, which would harmonize Ramusio's statement that Verrazano made a second voyage to America and lost his life there. But Spanish official documents show that Juan Florin, with other French pirates, was captured at sea in 1527, and in November hanged at Colmenar, between Salamanea and Toledo. A letter is said to have been found, bearing date Paris, Nov. 14, 1527, which speaks of Verrazano as preparing an expedition of five ships for America. It is not possible, indeed, to reconcile the statements regarding him after his return from America. (J. H.)

VETO. During the colonial period in the history of this country, all legislative authority being ultimately in the crown and parliament of Great Britain, the veto power as now recognized had no existence; as all colonial legislation took effect under the assent of the British power, that specific limitation known as the veto power was merged in that which had a more universal nature. The people of the colonies naturally regarded with disfavor that which appeared to them to be an arbitrary interference with the right of popular government. With the assertion of the right of self-government by the colonies, the effect of this sentiment was not dissipated, and hence we find that the necessity for an executive veto was not readily recognized by them.

Massachusetts in her constitution of 1780 adopted the provisions that, with hardly any change of substance or form, have passed into the Constitution of the United States and of the States generally. These provisions required that the acts of legislation should be signed by the governor or that he should return them to the legislature with his objections, whereupon they could only take effect when passed by a two-thirds vote. Until the charter of 1726 the governor had an absolute veto upon the legislation.

Under the frame of government for Pennsylvania in

1682 and that of 1683 the governor had the initiation of measures of legislation, which was equivalent to an absolute veto, while under the charter of 1701 he had an absolute veto given in terms, of acts tending to change that organic law. By the constitution of 1790 the provision as to the veto was adopted in the form in which it had been adopted by Massachusetts in 1780, and this provision was continued in the constitution of 1838.

The Massachusetts clause was adopted in the constitution of New York in 1821, and was continued in the constitution of 1846. Connecticut adopted the provision in the same general form, but allowed a mere majority to overcome the veto in the constitution of 1818. Virginia did not embody such a clause in her constitution until 1870.

The executive veto of legislation may be regarded as a fixed part of our system of government, but reduced from an absolute negative of legislation to a check that may be overcome by the vote of a majority or a larger proportion of the legislative body. In most of the States two-thirds of the quorum is necessary, but in some a mere majority is sufficient.

At the present day the executive veto is recognized by the United States and all of the States except North Carolina, Ohio, Delaware, and Rhode Island. In every instance where the veto exists it may be overcome by a competent proportion of the legislative body. A vote of three-fifths is necessary for the purpose in Maryland and Nebraska. Two-thirds of the whole number elected is required for that purpose in Missouri. Two-thirds of a quorum is necessary in California, Colorado, Florida, Georgia, Illinois, Iowa, Kansas, Louisiana, Maine, Minnesota, Mississippi, Massachusetts, Nevada, New Hampshire, New York, Oregon, Pennsylvania, South Carolina, Texas, Virginia, and Wisconsin. A majority of all persons elected is required in Tennessee, West Virginia, Alabama, Arkansas, Indiana, Kentucky, and New Jersey. A majority of a quorum is required in Connecticut. In Vermont the vote is a merely suspensory act, subject to the action of the next session, and proceeds from the governor and council.

The Constitution of the United States provides that a bill presented to the President for his signature shall become a law unless returned in ten days, unless Congress by its adjournment prevents such return, and the States generally that have veto provisions have a similar clause varying as to the time within which the bill must be returned.

The Articles of Confederation did not provide for a veto, for that form of government did not admit of its application as an executive act, the States being represented in the system as sovereign communities. The Constitution of the United States followed the form originally adopted by Massachusetts requiring two-thirds to overcome the veto of the President. The discussion in the convention that framed the national Constitution exhibits differences of opinion on this subject, three plans being suggested—one for an absolute veto by the President, another proposed revision by the President and judiciary, and the third that which was finally adopted. The preponderating influence was in favor of a two-thirds vote. An attempt was made to confer a veto over laws of the States upon the Federal Government, but in its place power was conferred upon the federal judiciary to declare laws of States that were not in conformity with the Constitution of the United States of no effect. The question of vesting the veto power was discussed upon propositions to place the whole in the executive or partly in that officer and partly in the judiciary, but the final result was its being placed in the executive alone, qualified by the authority conferred on two-thirds of Congress to destroy its effect.

According to existing practice, the two-thirds of Congress competent to enact a law notwithstanding the President's veto is two-thirds of the number act-

ing as a quorum of the respective houses of Congress, and not two-thirds of the persons qualified to sit in those houses.

During the first half century under the Constitution the veto power was used for enforcing the executive views of the limitations of the Constitution upon the authority of Congress. The establishment of the Bank of the United States at the commencement of the government divided opinion on the question of its constitutionality, which culminated in the exercise of the veto power by Pres. Jackson to prevent the recharter of that institution. Another subject of grave differences was the constitutionality of any attempt on the part of Congress to create and maintain internal improvements within the territory of the States. Both Madison and Jackson applied the veto to prevent the exercise by Congress of such power, which they regarded as infringing upon the sovereignties of the States, neither, as they regarded the matter, expressly conferred upon Congress nor necessary for the exercise of such as had been expressly conferred.

The frequent use by Pres. Jackson of the veto power produced a political reaction against its employment in the manner that was by many regarded as tending to suppress efforts for the development of the material resources of the country. The creation of internal improvements to connect together the great water-ways of the country, the magnitude and interstate relationships of which were regarded as rendering the action of the general government essential to their institution, gave prominence to the discussion of the question of the veto power.

Another interest that gave animation to the dissension was the growing opinion that the revenues of the country should to the largest extent be obtained from imposts, duties upon imported goods, as means of developing the material resources of the country. The rigid construction of the powers of Congress that was insisted upon by those who adhered to the school of strict construction of the Federal Constitution had found expression in the exercise of the veto power professedly for the vindication of the limitations imposed by the Constitution upon the powers of Congress.

Another subject that has induced the active exercise of the veto power was the interests connected with the institution of slavery, that culminated in the rebellion of 1861. The period of reconstruction that followed the close of this rebellion brought into conflict local and general interests, and the veto power was used by Pres. Johnson to enforce his views of the constitutional relations of the States to the Federal Government. Prior to the close of the period of reconstruction the absorbing political topic in the United States was the balance of power between the general government and the States, and the form in which the veto power was placed by the Constitution, and the mode of its subsequent exercise may be regarded as largely influenced by the pendency of that fundamental question. To reach a balance between national and local sovereignties that should give efficiency and unity to the national government without suppressing or impairing the efficiency of the States in the exercise and development of their internal powers and resources, was a problem that had neither upon theoretical or practical grounds been solved in the experience of mankind, and if, while engaging the profound thought of statesmen, it should happen to excite jealousy among those favoring the one or the other source of public authority, it ought not to be regarded with surprise.

While the question of the balance of power between the States and the national government must remain indefinitely subject at any time to produce animated discussion and contrarities of opinion in the United States, still the occasion that gave the greatest interest to this discussion has passed with the abolition of slavery, which by dividing the country upon lines that expressed fundamental differences in their social and economic structure gave direct interest to every sug-

gestion that tended to weaken the national government as against the States.

The prominence of questions of constitutional authority in the vetoes that occurred in the early history of the country tended to associate that power specifically with questions of that character, and to create an opinion that it was improperly used where the occasion of its use was a difference between the executive and Congress as to the policy of public measures. The Constitution drew no such distinction, while it provided ample means for subjecting the action of Congress to the limitations imposed upon it by the Constitution, by conferring authority to uphold those limitations upon the national judiciary. The circumstance that the proper effect of the veto under the Constitution was to require Congress to act by a larger number than a mere majority in certain cases, points the conclusion that the object of the veto was to secure mature consideration in such cases, and that object would embrace questions of policy as well as those that involve constitutional powers. Viewed in this light, the constitutional veto may be regarded as a power placed in the hands of the executive, by which a more mature consideration may be required on the part of Congress than what is implied by its acting by a mere majority. Such executive authority does not contradict the principle of representative legislation, but only exacts a more full expression of the legislative mind in cases where differences exist between the opinions of the executive and the legislative departments of the government. The fact that the termination of a session of Congress before the expiration of the time allowed by the Constitution for the action of the President upon bills presented to him for his approval may, and often does, defeat legislative action, may be regarded as an accident of the system that is unavoidable, and not as impugning the principle that under no circumstances should the executive will prevail over that of the legislative body; although advantage may be taken of that fact to defeat legislative action, yet the result can only be ascribed to the abuse of a proper power which may not be dispensed with, although possible to be abused.

It is plainly inferrible from the nature of the executive office that the veto was not intended to interfere with matters of detail in legislation, for a minute inquiry on the part of the executive into the details of legislation would be inconsistent with the proper discharge of the executive duty that demands a general oversight of the interests of the government. As means of protecting the great interests of the country, its nature can be readily understood, for legislative bodies are likely, notwithstanding the checks and guards afforded by parliamentary organization, to act at times hastily and improvidently, especially under the influence of excitement arising from popular apprehensions of public evils, and for the vindication of the principles that sustain the administration of justice and a wise public policy, such means of securing deliberation can readily be understood. As parliamentary bodies are liable, notwithstanding the means of securing deliberation afforded by the experience of government, to act without due deliberation, it would seem necessary that some means should be devised for the protection of the important public interests in such an event, and the executive veto is the only means for that purpose that has been proved by the experience of government. (A. J. W.)

VICKSBURG, SIEGE OF. After the battle of Corinth, Oct. 3-4, 1862 (see **CORINTH**), Gen. Grant, in command of the department of the Tennessee, proposed to Gen. H. W. Halleck, then general-in-chief of all the national armies, a movement having as its objective the capture of Vicksburg. His views being approved, he, on Dec. 8, ordered Gen. Sherman to move down the Mississippi from Memphis with this ulterior object, while Grant himself should co-operate with him by land. The cap-

ture of his secondary base of supplies at Holly Springs, Dec. 20, and the difficulty of protecting the long line of communications, induced him to abandon the land expedition and take command in person of the movement down the Mississippi. On arriving at Milliken's Bend, 20 miles above Vicksburg, on the west side of the river, he found Sherman there, and directed him to attempt the capture of the strongly fortified position of Haines' Bluff, on the Yazoo River. Sherman crossed the Mississippi at the head of 32,000 troops, and ascended the Yazoo, landing immediately below the bluff. His assault was repulsed with severe loss, and Grant, establishing his head-quarters at Memphis, commenced preparations for co-operation with Sherman in a concentrated movement against Vicksburg. On Dec. 29, 1862, he arrived at the head of 50,000 men at Young's Point, nearly opposite the mouth of the Yazoo River, 3 miles above Vicksburg, Admiral Porter co-operating with a fleet of gun-boats carrying 280 guns and 800 men. Various modes presented themselves for reaching the high ground behind Vicksburg, whence only it could be assaulted. Three received especial consideration: (1) By crossing the river below Vicksburg and co-operating with Gen. Banks, who was ascending the river in command of an expedition from New Orleans; (2) By constructing a canal across the peninsula opposite Vicksburg for the passage of gun-boats and transports, and which would be kept open as a line of communication for supplies; (3) By turning the Mississippi out of its course and crossing its bed. Each of these plans, specious in theory, was found impracticable, mainly on account of the weather, the swollen condition of the river, and the state of the country. After spending about three months at Young's Point "trying," Gen. Grant says, "to get on high land and waiting for the river to recede," he determined to attempt a plan more hazardous than any of the others. This was to run the batteries of Vicksburg with his gun-boats and transports, march his troops down the west bank of the Mississippi from Milliken's Bend to a point in the neighborhood of New Carthage, and ferry them thence over to the east bank. The movement was begun March 29, when the troops set out on their march to New Carthage and Hard Times. On the night of April 16 the fleet ran the batteries of Vicksburg under a hot fire. On April 29 Gen. Grant reconnoitred Grand Gulf, and finding it too strong to promise success to an assault, ran its batteries with his gun-boats, etc., as he had done those of Vicksburg, to a point farther down the river. On the 30th the advance of his army was ferried across to the east bank at Brownsburg, 30 miles south of Vicksburg, and forthwith marched out in the direction of Port Gibson, near which, on May 1, it encountered Gen. Bowen at the head of some 7000 men, defeated him, and chased him for some miles. On May 3 the Big Black River was reached and also the Mississippi at Grand Gulf, at which place he made his head-quarters for a few days.

Grant now found himself between two hostile armies—one with head-quarters at Jackson, 45 miles east of Vicksburg (of which Gen. Joseph E. Johnston, sent as Confederate general-in-chief of the Vicksburg campaign, took the command on May 13), the other under Gen. J. C. Pemberton, with head-quarters at Vicksburg. With the view of relieving his front, Grant had ordered Sherman to make a feigned attack on Haines' Bluff, which compelled the Confederates to despatch troops to its relief. This feint had been successfully executed on April 30, whereupon Sherman marched to join the main army. Three days were spent in Grand Gulf in ferrying over Sherman's army and reconnoitring towards Vicksburg. By the evening of May 6 Sherman's corps had joined the main army in Grand Gulf, and it became Grant's policy to cut himself adrift from his base, and, by a rapid movement, to strike first the one and then the other of the hostile

armies ere they had time to unite. On May 7 the movement commenced, with the assault of Vicksburg from the rear as its ultimate object. On the 12th McPherson leading Grant's advance met at Raymond a force under Gen. Gregg from Jackson. This was defeated and driven back on that city. The next move was direct on Jackson, where Johnston now was at the head of 12,000 men, and on the 14th this place was taken, the supplies collected there destroyed, and the railroad bridge broken down. Johnston lost 845 men and 17 guns. Grant instantly faced to the west against Pemberton, met him on the 16th at Champion's Hill, and, after the hardest fought battle of the campaign, defeated him with a loss of 1400 put *hors de combat*, 2500 prisoners, and 24 guns. On the 17th the enemy was again encountered entrenched at Big Black River bridge, and, after a hard fight, driven across the river, with a heavy loss in killed and wounded, and of 1751 men captured as well as 18 guns. On May 18 the outworks of Vicksburg were reached, and the Confederates driven within the fortifications. The city was forthwith invested, and from this date the siege is to be reckoned.

Grant, believing Pemberton's troops demoralized by their defeats at Champion's Hill and Big Black, ordered a heavy assault on the 19th and another on the 22d. Both resulted in discomfiture, although some of the enemy's advanced positions were captured. On the 23d the siege was begun in regular form, and the troops set to work in fortifying the position and pushing it forward towards the enemy's parapets.

Vicksburg is situated on the east bank of the Mississippi, a mile below the junction of the Yazoo, and stands on an uneven bluff, much broken up on the land side with ravines, having an average height of from 200 to 250 feet above the river. Its defences commenced 3 miles below the town and followed the highest ridge in an east and north-east direction till they reached the Jackson Road, where they turned due north and then west for 2 miles till they reached the river at Fort Hill. The total length was about 7 miles. The line had been selected in the autumn of 1862, and most thoroughly fortified during the winter and spring. At an average distance of 200 yards batteries had been constructed, the parapets 25 feet thick, 10 feet high, and ditch 7 feet deep. The works were defended by 128 guns. In addition to land-defences, the circuit was made complete by a series of water-batteries stretching along the Mississippi from Fort Hill on the north to where they met the land-batteries on the south. These mounted 30 pieces siege artillery of the heaviest calibre and 13 pieces field artillery. The troops for the defence numbered over 20,000 effectives, in four divisions, under Gens. Stevenson, Forney, Smith, and Bowen, with the addition of Waul's legion. Stevenson held the right, Forney the centre, Smith the left. Bowen's division and Waul's legion were in reserve.

Grant had 71,000 troops to conduct the siege and defend his rear against Johnston, who had now been reinforced to over 30,000. By June 30 he had 220 military guns in position, all light field-pieces except 6 32-pounders, supplemented by a battery of heavy guns from the navy—in all 248 pieces. Sherman held the right of the besieging force, starting from the river; McPherson came next; McClelland stood left of him, holding the road south to Warrenton. Lanman's division, which arrived at this time, held the extreme left. Grant's head-quarters were at the north-east angle, where Sherman's and McPherson's corps touched. His whole line measured about 15 miles. A sap which had been run up to the enemy's parapet was exploded on the 25th June without any definite effect, and an attempt to charge after the explosion resulted in failure. On July 1 another mine was exploded, and destroyed a redan, killing and wounding a number of its occupants, but no attempt was made

to charge. From this time the work of mining and pushing the position nearer the enemy went on with renewed vigor. Already the approaches had reached the enemy's ditch, and orders were given to prepare for the assault on July 6. Meantime the garrison had begun to suffer from failure of supplies. An intercepted despatch had informed Grant that Johnston had planned an attack to relieve it, while Pemberton was to cut his way out. The line of defence which his reinforcements enabled Grant to make towards Jackson foiled this scheme, as the means taken by him in connection with Admiral Porter had on the 21st equally foiled a scheme of Pemberton's to leave the city for the Louisiana side by boats. When Pemberton saw that all hope of relief or escape had vanished, he, on July 1, addressed his four division commanders, asking whether they would counsel evacuation. Two directly counselled surrender; the other two did practically the same, saying that an attempt to evacuate would fail. Already Pemberton had received a message from Johnston suggesting he should negotiate for the release of the garrison with their arms.

On July 3 a white flag appeared on a portion of the works and hostilities along that line ceased. Shortly thereafter Gen. Bowen, and Pemberton's aide-de-camp, Col. Montgomery, appeared with a white flag and bearing a letter asking an armistice "for — hours" to allow commissioners to meet to arrange terms of capitulation. This Grant declined to accede to, but wrote, saying he would meet Pemberton to arrange for unconditional surrender of city and garrison, promising that the latter would be treated with all the respect due prisoners of war. At 3 p. m. Pemberton appeared with some of his officers and met Grant with some Union generals. Grant would accede to nothing but unconditional surrender, but agreed to send a letter embodying his final terms at 10 p. m. These terms—the surrender of the city and of the whole force, with their arms and munitions, as prisoners of war, not to serve again till properly exchanged—were accepted by Pemberton, and at 10 a. m., July 4, the Confederate troops marched out, each division taking position in front of its works, where it stacked arms, laying its colors upon them, and then marched back to the city. Logan's division marched in and took possession. Paroles were made out and signed as quickly as possible, the prisoners being meanwhile fed from the Union stores. On July 11 they marched out unarmed, and proceeded to the neighborhood of Enterprise, Miss., and Demopolis, Ala., where they remained till they were exchanged in the following September. The number of men actually paroled was 29,591, namely, 2166 officers and 27,425 men. There were also 790 who refused parole and were sent north as prisoners of war, so that the total force surrendered was, in round numbers, 30,400. The artillery found in the place numbered 172 pieces, 67 of which were siege-guns. Grant's total loss in the campaign (including expedition against Jackson) was a little under 10,000. Pemberton's loss, including men surrendered, has been estimated at 46,000. The total length of the siege, from May 18 to July 3, 1863, was 47 days.

The events of July 4, 1863, at Vicksburg and Gettysburg, sounded the death-knell of the Confederacy. The struggle was prolonged indeed, and maintained with the desperate resolution of brave men, but of men conscious that defeat awaited them in the end. Grant, for his brilliant services, was promoted to major-general in the regular army, and Congress, on its meeting, passed a vote of thanks to him and his army and voted him a gold medal.

(J. H.)

VICTORIA, Queen of Great Britain and Ireland, and Empress of India, daughter and only child of Edward, Duke of Kent, was born at Kensington Palace, London, May 24, 1819, her mother being Victoria Mary Louisa, daughter of Francis, Duke of Saxe-Coburg-Saalfeld, and widow of Prince Charles of Leiningen. The Duke of Kent died when his daughter, Alexandrina

Victoria, was only eight months old, but her mother fulfilled the important duties devolved on her with admirable care and judgment. On Victoria's accession to the throne, on the demise of her uncle, King William IV., June 20, 1837, she was accomplished not only in the continental languages, drawing, music, and some of the sciences, but she was thoroughly instructed in the principles of the British Constitution. Retaining the late king's ministers, her first public act was to dissolve Parliament in person on July 17, reading her speech from the throne. Next year her coronation was celebrated, June 28, amid general rejoicing. Although but eighteen years of age at her accession, the dignity with which she bore herself, her strict propriety of conduct, and amiability of character won the hearts of her subjects, and she has retained their love and respect to the present day. On Feb. 10, 1840, she married her cousin, Prince Albert of Saxe-Coburg-Gotha, who proved not only a husband devoted to herself, but able and ready to further the welfare of her people. By him she has had nine children—four sons and five daughters—of whom seven still live. Her offspring are, the Princess Royal, Victoria, now Empress-Dowager of Germany, born Nov. 21, 1840, married Jan. 25, 1858, to Frederick William, then Crown Prince of Prussia, and later Emperor of Germany; Albert Edward, Prince of Wales, heir-apparent to the throne, born Nov. 9, 1841, who married March 10, 1863, Princess Alexandra of Denmark; Princess Alice, born April 25, 1843, married in 1862 to Prince Frederick of Hesse, died Dec. 14, 1878; Prince Alfred, Duke of Edinburgh, born in 1844, married, 1874, Marie Alexandrovna, only daughter of the Czar of Russia; Princess Helena, born 1846, married, 1866, Prince Christian of Schleswig-Holstein; Princess Louise, born 1848, married, 1871, the Marquis of Lorne, eldest son of the Duke of Argyll (the only child of the Queen who married a subject); Prince Arthur, Duke of Connaught, born 1850, married, 1879, Princess Louise of Prussia, daughter of Frederick Charles, the "Red Prince," Leopold, Duke of Albany, born 1853, married, 1882, Princess Helen of Waldeck, died 1884; Princess Beatrice, born 1857, married, 1885, Prince Henry of Battenberg.

The leading events of Victoria's reign are here briefly noted. The year 1839 was marked by the turbulent proceedings of the Chartists. Their principles, which were embodied in "the five points of the charter," have since been largely recognized in legislation. In 1840 Sir Rowland Hill's penny-postage scheme was put in operation. The war against China, 1840-42, was closed by a peace, by which England secured a large war-indemnity, the island of Hong-Kong, and the opening of four ports in addition to Canton. In 1841 Sir Robert Peel came into power, and after great popular agitation, his administration repealed the corn-laws in 1846. Serious wars occurred in Afghanistan in 1842, and in the Scinde in 1843. In 1845 the great Sikh rising took place in India, which was not quelled till 1849. It resulted in the annexation of the Punjab. The famine in Ireland through the failure of the potato-crop in 1846 drove multitudes of its people from their homes to find an asylum in America. The widespread distress led to a revision of the poor-laws for the whole empire. In 1848, the year of European revolutions, the throne of Victoria alone stood secure, though there was an uprising in Ireland, and the Chartists gave some trouble in London. In 1849 Queen Victoria for the first time visited Ireland, and was received with demonstrations of loyal respect, while the name of the Cove of Cork, where she landed, was changed to Queenstown. On May 1, 1851, the World's Fair in Hyde Park, London, was opened by the Queen and Prince Albert, who had energetically promoted this industrial exhibition. In this year the first submarine telegraph cable was laid across the Straits of Dover. The close of 1852 was marked by the death of the Duke of Wellington, who had been the sponsor to Prince Arthur.

Ten years of peace were succeeded by new wars. In 1854 war with Russia led to the Crimean campaign by the united forces of England, France, Italy, and Turkey, and was closed by the capture of Sebastopol, Sept. 9, 1855. The formidable Indian mutiny burst forth in 1857 and was suppressed only after a long and desperate struggle. The great East India Company was abolished and its vast empire transferred to the crown of Britain. In this year the title of Prince Consort was conferred on the Queen's husband. A volunteer movement for the defence of England was inaugurated in 1859. The civil war in America caused much distress in England owing to the cotton famine. To Victoria the close of 1861 was darkened through the death of her devoted husband. Her grief was testified by many years of seclusion from the public. Besides architectural tributes to his memory, she caused the publication of his *Speeches and Addresses* (1862). Lieut.-Gen. Charles Grey prepared under her direction *The Early Years of H. R. H., the Prince Consort* (1867), and Sir Theodore Martin *The Life of H. R. H., the Prince Consort* (3 vols., 1875).

To resume our chronology: in 1866 telegraphic communication was established between Europe and America by the laying of the cable between Valentia, Ireland, and the coast of Newfoundland. Fenian troubles marked the year 1867. The same year was signalized by the passing of Disraeli's reform act, establishing household suffrage in boroughs and occupation franchise in counties, and by the formation of Canada into a dominion and the transference of the seat of government to Ottawa. In 1869 the Established Church of Ireland was disestablished and disendowed. This was followed, in 1870, by the passage of a land-act for Ireland, establishing courts for fixing reasonable rents. This has been the precursor of several kindred measures, down to the Ashbourne act of 1888, the general object being to restore peace to that unfortunate country. The purchase of commissions in the army was abolished in 1870. In this same year the elementary education act was passed for England and, in 1872, a kindred measure was passed for Scotland, education being now compulsory in both these countries.

At the close of 1871 the life of the Prince of Wales was for a time in imminent danger through typhoid fever. In 1871 the Emperor Napoleon III. found asylum with his wife and son at Chislehurst, Kent, where he died in 1873. In 1876 Parliament, at the instance of Disraeli, passed a royal title-bill, by which Victoria was made Empress of India. In 1877 that favorite minister of state was raised to the peerage with the title of Earl of Beaconsfield. In 1878, at the end of the war between Russia and Turkey, the island of Cyprus was ceded by the latter country to England. A war with the Zulus in South Africa, which broke out in 1879, was noted for the slaughter of the young Prince Napoleon, a volunteer with the British troops. Victoria erected a monument to his memory in Zululand.

Troubles in Ireland continued, and on May 6, 1882, Lord Frederick Cavendish and Mr. Burke were assassinated in the Phoenix Park, Dublin. Parliament then passed an Irish coercion bill of the most stringent nature, which still remains in force. For the war in Egypt in that year see ARABI PACHA. Lower Egypt was occupied by British troops and this led to complications with the fanatical Arab tribes of the Soudan, who, under the Mahdi, threatened Lower Egypt, slew Gen. Gordon, who had gone to Khartoum to pacify the region, and came in collision with the force which had been despatched too late for his relief. A bitter and undecided "little war" was the result. One of its most prominent events was the battle of Suakim, in December, 1888, which resulted in the decisive repulse of the Arabs from that town.

In the early spring of 1884 died the Duke of Albany, who of all the Queen's children was said, in point of

tastes and culture, most to resemble his father. In December of this year Parliament passed an act by which practically the whole adult male population of Britain is enfranchised. Since then Parliament has been mainly occupied with Irish questions, the central one being that of Home-Rule.

In the spring of 1888 Queen Victoria visited Italy for the sake of her health and on her return journey spent three days in the month of April at the Schloss Charlottenburg, near Berlin, where her son-in-law, the Emperor Frederick, was to die on June 15. In the fall the Dowager-Empress came to her mother at Windsor.

A marked peculiarity of Queen Victoria has been her predilection for Scotland and its people, her favorite personal attendants, notably John Brown, being mainly of this nation. In 1847 she took up her first residence in the Highlands at the old castle of Ardyvenkie, Invernesshire, and since then her visits here have been, at least, annually. In 1852 Prince Albert acquired the fee-simple of the castle of Balmoral on the Dee, Aberdeenshire, with a property of 40,000 acres, largely deer-forest, and built a new castle on the site of the old one. Here, more than elsewhere, the Queen has ever since made her home proper, spending generally two months in autumn. In its neighborhood some private family monuments have been erected, and her dearest associations seem to cluster. Her majesty's literary productions are all associated with her Highland life, and tell of excursions amid the mountains and glens, of Highland sports, of her own home life, and of Highland life and usages.

Finally, her reign has been one of great activity, scientific, literary, and artistic, and books have multiplied in an unprecedented degree. The great names in these departments will be found under their separate entries. Victoria's name, like those of her predecessors, Elizabeth and Anne, marks an illustrious era in literature. (J. H.)

VINCENT, JOHN HEYL, bishop in the Methodist Episcopal Church, was born at Tuscaloosa, Ala., Feb. 23, 1832. He received an academical training, and entered the Methodist ministry. He has had charge of churches in New Jersey, at Newark, Franklin, and Irvington, 1852 to 1856; in Illinois, at Joliet, Mt. Morris, Galena, Rockford, and Chicago, from 1857 to 1865. He was made Sunday-school agent in 1866, and corresponding secretary of the Methodist Sunday-school Union in 1868. While engaged in active promotion of the cause of Sunday-schools he became convinced of the need of popularizing higher instruction in this country. Young men and women eager to be taught lacked opportunities to procure the training to which they aspired. The problem then was to diffuse liberal culture above the range of the common schools. By the generous aid of Mr. Lewis Miller Dr. Vincent was enabled in 1874 to put in practice at Chautauqua certain ideas which had been developed in his mind. The result has been partly described under CHAUTAUQUA, but the work has advanced to greater perfection since that article was published. Dr. Vincent was the superintendent of instruction there until 1884, and has since been chancellor of Chautauqua University. In 1888 he was chosen bishop by the General Conference. He has published *The Chautauqua Movement* (1886), *The Home Book* (1886), and manuals relating to Sunday-schools.

VINTON, ALEXANDER HAMILTON (1807-1881), clergyman, was born at Providence, R. I., May 2, 1807. His father, David Vinton (1774-1830), was a prominent merchant. Alexander, after spending three years at Brown University, studied medicine, and practised at Pomfret, Conn., but in 1833 abandoned medicine for theology. After studying at the Episcopal General Seminary in New York, he was ordained deacon in 1835 and priest in 1836. He was successively rector of Grace Church, Providence, 1836-42, St. Paul's, Boston, 1842-58, Holy Trinity, Philadelphia,

1858-61, St. Mark's, New York, 1861-70, Emmanuel, Boston, 1870-77. He then retired to Pomfret, but afterwards was professor of systematic divinity in the theological school at Cambridge. He declined the bishopric of Texas in 1857, and was candidate in other dioceses, but was not elected. With a noble voice and presence, he was impressive alike as preacher and pastor, and has been pronounced one of the greatest men of the Episcopal Church. He died at Philadelphia, April 26, 1881. His only publications were *Sermons* (1855).

His brother, FRANCIS VINTON (1809-1872), was born Aug. 29, 1809, graduated at West Point in 1830, and published *Arthur Tremaine, or Cadet Life* (1830). He served on topographical and engineer duty till 1836, when he resigned, having managed to study law at Harvard and be admitted to the bar at Portsmouth, N. H. But like his brother he turned to theology, entered the same seminary, and was ordained deacon in 1838, and priest in 1839. He became rector of St. Stephen's, Providence; of Trinity, Newport, 1840; of Emmanuel, Brooklyn, 1844; of Grace, Brooklyn, 1847. He declined the bishopric of Indiana in 1849, and in 1855 became an assistant minister of Trinity, New York, with charge of St. Paul's. In 1869 he was made professor of ecclesiastical law and polity in the General Seminary. He published *Lectures on the Evidences of Christianity* (1865), and *Commentary on the Canon Laws* (1870). He was a leader of the High Church party, as his brother Alexander of the conservative evangelicals. He died in Brooklyn, Sept. 29, 1872.

VIOLET, the common name of the genus *Violet*, the type of the botanical order *Vio-*
See Vol. XXIV. *laceae*. The genus is a large one, p. 241 (p. 250 comprising about 200 recorded species of herbaceous, perennial (rarely annual) plants, the most of which are favorites of flower lovers. They possess short rhizomes or underground stems, alternate leaves, and solitary flowers, nodding or declined. The flowers have nearly equal sepals, produced at the base into a free appendage; the petals are unequal, the lower one produced into a sac or spur at the base.

Of the American species, *V. cucullata*, the common blue violet, is much the best known, and is found throughout the country. Other common species are *V. palmata*, the hand-leaf violet; and *V. pedata*, the birds-foot violet, a species with large and handsome flowers of blue or purple color, the two upper petals sometimes deep violet and velvety like the pansy. In addition to the blue, there are several species of white and yellow violets. Of the latter may be named *V. rotundifolia* and *V. pubescens*, the latter a fine, tall species, with an aerial stem 6 to 12 inches high. It bears yellow flowers, with striated petals, and thrives well under culture. Of the white species may be named *V. blanda*, the small scented violet, its flowers being white, small, and with a faint sweet perfume. It grows in wet meadows in company with another white-flowered species, *V. lanceolata*, the lance-leaved violet.

There are representatives of a second genus in the Northern United States, *Solea*, the green violet. *S. concolor* occurs from New York to Illinois and southward. It is a homely little plant, with small, greenish-white flowers, and has the power, in common with many other violets, of projecting its seeds to a considerable distance from the plant.

Europe possesses many beautiful species of violets, the favorite among them all being *V. odorata*, the sweet-scented violet. This is a low, creeping plant, the flower generally blue, but occasionally of other colors, and with a very delicate fragrance, much superior to that of any American violet. It has been naturalized here to some small extent. *V. tricolor*, a pretty little plant, is the source of all our cultivated varieties of pansies, heartsease, etc. Most of the cultivated vio-

lets are of Old World species, the American violets generally being not showy in culture, though *V. pedata* responds well to cultivation, and is becoming common in gardens. (C. M.)

VIOLLET LE DUC, EUGENE EMANUEL (1814-1878), a French architect and author, was born at Paris, Jan. 27, 1814. He studied architecture, at first under Leclerc, occupying himself specially with the Gothic architecture of the middle ages, and thereafter by observation in the course of tours of investigation in Italy, Sicily, and Southern France, wherein he paid attention chiefly to Greek and Roman remains. In 1840 he was made inspector of the restoration of the Sainte Chapelle, Paris, and was successively intrusted with the restoration of the ancient churches of Verzeilay, of Saint Père, Montreale (Yonne), Poissy, Carcasone, and Semur; and of the Hôtels de Ville of Saint Antoine and Narbonne; and in 1845 with the restoration of the Church of Notre Dame, Paris. His success here led to his appointment as architect of the Abbey of St. Denis. In 1849 he restored the fortifications of Carcasone and superintended the embellishment of the Cathedral of Amiens. In 1853 he was appointed one of the three government inspectors-generals of religious edifices, in which capacity he conducted the restoration, among others, of the Church of Notre Dame, Chalons sur Marne; of the Cathedral of Laon, and of the Chateau Pierrefonds. In 1863 he was named professor of art, history, and aesthetics in the reorganized School of Fine Arts, but soon resigned. During the siege of Paris, 1870-71, he aided as an architectural engineer in the defence of his native city, and was lieutenant-colonel. Meanwhile his republican and free-thinking views, expounded through the press, raised a clamor against him. He was, however, charged with the construction of the Protestant Cathedral of Lausanne, Switzerland, and the restoration, for the Comte de Paris, of the Chateau d'Eu. But, owing to clerical opposition in 1874, he resigned his position as inspector of diocesan edifices and ceased to be architect of the Cathedrals of Rheims, Amiens, Clermont, and Paris, though retaining the office of architect of St. Denis. In 1874 he was elected to the Chamber of Deputies as republican candidate for Montmartre. It was on his report as a member of the Commission on International Expositions that the project of the palace of the Champs de Mars and the Trocadero united by a gallery was adopted for the Paris exposition of 1878. He latterly occupied himself with questions of the fine arts, and, among other things, proposed to multiply the statues of great men in Paris, and advocated the use of the Phrygian bonnet for the statues of Liberty. He died suddenly at his country-house, near Lausanne, Sept. 17, 1879. Among his publications are *Dictionnaire raisonné de l'architecture française de XI.-XVI. Siècle* (Paris, 1854-1868, 10 vols; a twice-crowned *chef d'œuvre*); *Dictionnaire raisonné du mobilier Français de l'Époque carolingienne à la Renaissance* (1854-1875); *Lettres sur la Sicile* (1860); *Entretiens sur l'Architecture* (1858-1872); *Cités et ruines Américaines* (1862-63); *Chapelles de Notre Dame de Paris* (1869); *Habitations modernes* (1874-75); *Histoire de l'habitation humaine* (1875); *L'Art russe* (1877).

VIRCHOW, RUDOLF, German pathologist and publicist, was born Oct. 13, 1821, at Schivelbein, Pomerania. In 1843 he graduated in medicine from the University of Berlin, and began to lecture on anatomy, being also prosecutor of the Charité hospital. In 1847 he established in Berlin, in conjunction with Reinhardt, the *Archiv für pathologische Anatomie und Physiologie und für Klinische Medizin* (from vol. xxi. by Virchow alone). This periodical, now having over 80 volumes, is recognized as one of the most authoritative in the world. In 1847 Virchow, in connection with Leubuscher, founded also the *Medical Reform*. In 1848 he was deputed by the government to investigate the nature of the typhoid epidemic in upper

Silesia, and his report took high rank in sanitary science. Aroused by the Revolution of 1848 he entered the political arena as a liberal leader, and was elected to the Prussian House of Deputies, but was declared ineligible on account of his age. His liberal politics also served to deprive him in 1849 of his lectureship, whereupon he accepted a call to the chair of pathological anatomy in the University of Würzburg, where he obtained fame by his lectures on cellular pathology. In 1852 he investigated, by request of the Bavarian government, the famine in Spessart; and in 1859, at request of the Swedish government, he investigated in Sweden and Norway the causes of leprosy. In 1856 he was recalled by the University of Berlin to assume the chair of pathological anatomy and to become director of the Pathological Institute, which he soon raised to the first rank among such establishments. Since 1859 he has, as a member of the city council of Berlin, devoted great attention to matters of sanitary science. Since 1862, as member of the Prussian House of Deputies, he has consistently opposed Bismarck's arbitrary policy, the governmental centralization, and the military domination. Though he had objected to the constitutionality of the creation of the German Empire in 1880 he entered the Reichstag, where he soon became famous by his coinage of the watchword "*Kulturkampf*." In the wars of 1866 and 1870 Prof. Virchow was director of the German hospital service. In 1869 he helped to organize the German Archæological Society at Innsbruck, and became a leader in the Berlin Anthropological Society. In 1873 he was chosen a member of the Academy of Sciences. As one of the instructors to the Berlin Workingmen's Union he actively engaged in popularizing science. In 1872, a German society having requested his withdrawal from the French scientific societies, he declined, saying a rupture of the scientific relations between the two countries would be contrary to the interests of civilization, of science, and of humanity. In 1879 he rendered some assistance to Dr. Schliemann, in the Troad, and he contributed the *Preface* and some appendices to his *Ilios* (1881), and two appendices to his *Troja* (1884). The cancerous disease that carried off Frederick III. in 1888 brought Virchow prominently before the world as the ultimate authority on the pathological problem. It has become evident also that he exerted a great political influence (in conjunction with Geffken and others) upon the liberal-minded but unfortunate emperor.

In Germany, until the time of Virchow (1847), the basic principles of medicine were *a priori* assumptions. He claimed that facts and experiments were the only admissible foundations for that science, no matter how long it would take to collect them or establish them. "Observations and experimentation only have permanent value; they will prove the fortress of scientific medicine, the outworks of which are pathological anatomy and clinical research." Schleiden had discovered the cell to be the fundamental basis of the vegetable tissues, and Schwann had found it to be the basis also of the animal tissues. A few geniuses, from Vesalius and Paracelsus down to Virchow, had slowly and gradually shaped the theory of diseases as local anomalies. It remained for him, after a series of observations and experiments, to proclaim his cellular pathology as a consistent carrying out of the theory. He announced the necessity of localizing disease in the smallest composing element, or the cell. Therapeutics, under the guidance of experimental methods, have undergone important changes in the light of this theory, and have become vastly more efficient and local in application. Thus far every new discovery of pathological facts has found a ready explanation by the cellular theory and its methods, and the largest proportion of recent progress in pathology has been owing, directly or indirectly, to the adoption of his doctrine of cell-growth. Important in its influ-

ence on biology generally, it has little less than revolutionized pathological study. Under this view diseases of the different organs which, until their essential elements were demonstrated, appeared to have nothing in common, are now seen to be results of the same process. Thus a strong tendency may be observed at work toward the classification and unification of disease and the resolution of complex forms into the simplest elements. In other words, all the elementary processes of pathology may be seen in the different tissues and organs producing the same effects, though the effects are manifested in a manner peculiar to each part. With the same fundamental lesion the disease is the same essentially, although wholly distinct in appearance. Since the great bulk of disease can be resolved into these fundamental processes, a scientific and durable foundation for pathology is established which is of the highest value and significance for philosophic medicine. "The search," says Prof. Huxley, "for the explanation of diseased states in modified cell life; the discovery of the part played by parasitic organisms in the etiology of disease; the elucidation of the action of medicaments by the methods and the data of experimental physiology appear to be the greatest steps which have ever been made toward the establishment of medicine on a scientific basis." (See PATHOLOGY in the ENCYCLOPEDIA BRITANNICA.)

In the course (1854-56) of his researches on vegetable parasites as among the causes of disease, Virchow invented the term *mycosis*, which has since been generally adopted. In the "Movement in Favor of Unity in Scientific Medicine" (in *Collection of Contributions to Scientific Medicine*, 1849) he spoke of the origin of life as a mechanical necessity, and in his three orations on *Life and Disease* (1862) he pointed to the transmutability of species as a necessary basis for the mechanical theory of life. He opposed the idea of Haeckel, that theories of natural selection should be taught in the public elementary schools, on the ground that facts only, and not theories, should have place there. The burden of his lecture at Munich, Sept. 22, 1877, is throughout a caution against evading the distinction between the problematical and the proven; "they are not on the same evidential level." He would teach, he said, "evolution, if it were only proved; it is, as yet, in the hypothetical stage; the audience ought to be warned that the speculative is only possible, not actual truth; that it belongs to the region of belief, and not to that of demonstration. As long as a problem continues in the speculative stage it would be mischievous to teach it in our schools. We ought not to represent our conjecture as a certainty nor our hypothesis as a doctrine." His principal works are: *Cellular Pathology* (4th ed., 1871); *Handbuch der Speciellen Pathologie und Therapie* (3 vols., Erlangen, 1854-62); *Pathology of Tumors* (3 vols., 1863-67), the most exhaustive and comprehensive work on that subject; *Die Entwicklung der Schädel-grundes* (Berlin, 1857); *Darstellung von der Lehre der Trichinen* (1866); *Treatises connected with State Medicine* (2 vols., 1879). He has also published: *Popular Lectures: Archaeological, Ethnological, etc.* (1866, *sqq.*); *Goethe as a Naturalist* (1861); *Aufgabe der deutschen Turnerer* (1864); *National Development and the Importance of the Natural Sciences* (1865); *Education of Women for their Vocation* (1865); *Hunger Typhus* (1868); *Severage and Drainage* (1869); *Problems of the Natural Sciences in the New National Life of Germany* (1871); *Die alt-nordischen Schädel zu Kopenhagen* (1871); *Ueber die Chlorose, etc.* (1872); *Technique of Dissection* (1876); *Liberty of Science in the Modern State* (1877); *Ueber die Waddas von Ceylon* (1881). Those whose titles are given in English have been translated into that language. (J. W. W.)

VIRGINIA CREEPER, the common name of a favorite American climbing plant, of the *Vitaceæ* or vine family, genus *Ampelopsis*, species *A. quinquefolia*, which occurs abundantly throughout the Atlantic

States, and extends as far west as Colorado. It is distinguished by a slightly 5-toothed calyx; the petals concave, thick, and expanding before they fall; the flowers in cymose clusters; the leaves digitate, with 5 oblong, lanceolate leaflets; the climbing tendrils digitate at end, and fixing themselves by dilated sucker-like disks at the tips. This is a common vine, growing in low or rich grounds, and climbing extensively, similar in habit and locality to the poison ivy or sumach, but easily distinguishable by its five leaflets, the poison ivy having but three. It blossoms in July, and ripens its small, dark blue berries in October, these forming an open grape-like cluster. At all periods it is an attractive feature of our woodland scenery, but particularly so in the autumn, when the leaves turn a bright crimson, and it stands out in rich contrast to the darker foliage of the trees to whose summits it has climbed. (C. M.)

VITICULTURE. The culture of the vine, or grape plant *Vitis*, is one of the oldest of field industries, and may be traced back to a very remote period in the history of mankind. The use of wine as a beverage is mentioned in the earliest literature of China and India, Egypt and Palestine, and was very prevalent in the great kingdoms of later antiquity. It was eventually prohibited by law in China and the vines ordered to be torn up, while the precepts of Mohammed put an end to wine-drinking among the vast multitudes of his followers, but in Europe it has continued without intermission, and the culture of the vine is one of the most important agricultural industries of Southern Europe at the present day. All the varieties of the European vine are supposed to belong to a single species, *Vitis vinifera*. In American vine culture, on the contrary, this species is only generally grown in California, native species being the basis of the culture in the Eastern States.

The vine was early discovered to be a native of America, the Norse discoverers calling the country Vinland, from the abundance of grapes which they found. It was not, however, until recent years that any definite effort to cultivate the native grape was made. Wine is said to have been made from the European grape in Florida as early as 1564, while in 1602 it is stated that there were about 2,000,000 vines in Paraguay. Vines were planted in Virginia about 1620, at a later date in Delaware, and in 1683 by William Penn, in Pennsylvania. Many subsequent efforts to introduce the European vine were made, but were all unsuccessful, either the severity of the climate or the great susceptibility of this species to the attacks of insect enemies preventing its growth. Experiments with native species were not made until somewhat late in the present century. In 1835 Major Adlum, of Georgetown, D. C., brought the Catawba variety to notice. Its culture was ardently taken up by Nicholas Longworth, of Cincinnati, and with such success that by 1867 there were 2000 acres planted near that city. The lack of hardiness of the Catawba caused the development of other varieties—the Concord, Norton's Virginia, and others—and the total American acreage in vines in 1867 was about 2,000,000. (For the native species of American vines, and the principal varieties, see GRAPE.)

On the Pacific *Vitis vinifera* was introduced by Spanish Franciscans about 1771. After California became part of the United States and the gold fever had subsided, agriculturists began the culture of the mission grape, the vines which they found about the old mission stations, encouraged by the fact that these would grow without irrigation. But the wine made from their fruit proved of poor quality, and other varieties of the European grape, and recently of the American grape, were introduced, with much improvement to the wine product.

In Europe the cultivation of the vine, except under glass, has its extreme northern limit near Berlin, 52° 30' N. lat.; its southern limit at 26° S. Palatable wines,

however, can be made only in a much narrower district, the chief wine-producing countries being France, Spain, Portugal, Germany (valley of the Rhine), Austria, and Italy. In North America the hardy native vines thrive as far north as Massachusetts, but wine cannot be profitably made above Southern New York, Pennsylvania, and Northern Ohio. The culture of the vine has hitherto not been extensively prosecuted in the Southern States, though it is probable that good wines could be produced throughout that region.

In viticulture soil and location have a great influence on the quality of the product, often from causes that are not apparent. A southern slope is important for the profitable growth of the vine, and light soils are best, even sandy loams, but mineral food, especially potash, is necessary, and the best European soil seems to be that arising from the disintegration of felspathic and volcanic rocks. American vines, on the contrary, seem to prefer calcareous soils. The soil needs to be deep and well drained, "wet feet" being generally thought injurious to the vine. There are several methods of propagation, as cutting, layering, and grafting, and seed planting to produce new varieties. Grapes vary readily from seed growth. Seeds from black varieties like the Concord, for instance, will occasionally yield pure white or greenish varieties without cross fertilization, though the latter is considered the most advantageous process. The seeds need to be obtained from fully ripe fruit, mixed with sand and kept moist until spring, when they are sown in boxes under glass or in the open ground, being covered with a half inch of soil. The seeds of hardy varieties do best if kept where they will freeze during the winter. The seedlings are set out when a year old and trained to a single stake until they produce fruit. After the grapes appear the inferior vines are destroyed, and those worthy of preservation propagated in the usual methods. It is very rarely that an improved variety appears, the chance of success not being one in a thousand, though there is still much room for improvement in our native grapes.

The most common method of grape culture is by cuttings. These are taken from the previous year's growth, 3 buds being usually left, though single bud-cuttings with 1 or 2 inches of cane are used in propagating rare varieties. The latter need to be grown with great care, and are usually started under glass during the winter. Another common method is by layering. The layer is but a cutting left attached to the parent vine and fed by it until it has developed roots of its own. The principal advantage of this method is that certain varieties which are not readily propagated by cuttings may be made to produce roots on layers, the vitality of the planted canes being longer preserved. Grafting is a very ancient method. It was much practised in Roman times, and is frequently described in Latin treatises on agriculture. Its principal advantage is in giving hardy root stocks to delicate varieties. The most usual method is to insert the scion in the crown of the plant below the surface of the ground. It needs to be tied in and the earth banked around it, this serving instead of the wax employed in aerial grafting. It is necessary, however, to prevent the scion from sending out roots of its own, and its rootlets need to be removed several times during the season.

There are various ideas about the best methods of growing the grape. The open trellis and frame training is most common in the United States. In Europe, where wood is less abundant, single stakes are often used, the vine being pruned more severely than the American species will bear. The several diseases and insect enemies to which the vine is subject are described under GRAPE and PHYLOXERA. The products of the vine are six in number: the fruit, which is largely used in the fresh state as an article of food; the dried fruit, or raisin, for which the sweeter grapes are used; the currant, which is the dried product of a

small seedless grape cultivated in the Levant; wine, the fermented juice of the grape; brandy, the alcoholic spirit distilled from wine; and tartar (the acid tartrate of potassium), which is deposited as a solid incrustation on the interior of casks in which wine is stored, and which, in its purified state, forms the cream of tartar of commerce.

Of these several products the American industry is confined to three only: the fruit, wine, and raisins. Grapes are grown very largely for table use, and the methods by which they can be kept in a fresh state until far into the winter add considerably to their consumption. Of recent years raisins, which were formerly produced only in Calabria, Sicily, and Turkey, have been successfully dried in California. (See WINES.) (C. M.)

VOGÜÉ, CHARLES JEAN MELCHIOR, MARQUIS DE, French archaeologist and diplomatist, was born at Paris in 1829. His father, Léonce, Marquis de Vogüé (1805-1877), was in early life a lieutenant of cavalry, but after the revolution of 1830 devoted himself to agriculture and iron-works until 1848, when he took part in forming the republic and supported the presidency of Louis Napoleon. But when the latter declared himself emperor Marquis de Vogüé again withdrew from public life, until 1871, when he was elected to the National Assembly and supported the monarchists. In 1853 his son, then Comte de Vogüé, set out for the east, where he devoted two years to exploring in Syria and Palestine. After returning to Paris he published several works of so high value that he was named a free member of the Academy of Inscriptions and Belles Lettres to fill the place left vacant by the Duc de Luynes. In 1871 M. Thiers named him ambassador to Constantinople, which office he held till 1875, when he was called to the embassy at Vienna. These positions, however, he owed rather to his fame as a scholar than to diplomatic ability, and on the accession of Pres. Grévy, in 1879, De Vogüé returned to France. He is author of the following valuable and handsomely illustrated works: *Les Églises de la Terre Sainte*, with 59 engravings (1859); *Inscriptions hébraïques de Jerusalem* (1864); a monograph on *Le Temple de Jerusalem*, with 50 plates, followed by an *Essai sur la Topographie de la Ville Sainte* (1865); *L'Architecture civile et religieuse du Ier au VIIe Siècle dans la Syrie Centrale*, with plates (1865-77); *Mélanges d'Archéologie Orientale* (1869); *Inscriptions Sémitiques*, 43 plates (1869-77). De Vogüé also edited the Duc de Luynes' posthumous work on the exploration of the Dead Sea.

VOLAPÜK, the "world language," invented by Johann Martin Schleyer, a Catholic priest, who was born at Oberland, Baden, in 1831, and at present resides in Switzerland. He became an ardent student of philology, and gained some knowledge of about 50 languages and dialects. His studies in this direction were largely devoted to the formation of a language which would be suitable as a medium of international intercourse, and in 1878 he published an outline of such a language, of which he issued a grammar and dictionary in 1880. He has since published numerous works on the subject; his system has been warmly welcomed in Germany and has attracted so much attention elsewhere as to call for a descriptive mention.

The idea of a world language is not new. Efforts have been made from time to time in this direction, the earliest being that of John Wilkins, Bishop of Chester, in 1668. There have been many later schemes proposed, recent ones being the "Ideography" of Simbaldo de Mos in 1863, and the "Alevato" of Stephen Pearl Andrews in 1877. All these, however, were based on metaphysical or other impractical conceptions, and have no value other than as literary curiosities. Schleyer's scheme was the first of a practical character. Recognizing that all existing languages have irregularities of grammar, orthography,

etc., which render them troublesome even to natives and occasionally unlearnable to foreigners, it was his object to produce a language prepared solely with a view to its practical utility, in which the irregularities and complexities of existing languages should be avoided and complete simplicity and regularity be gained. Unfortunately his native language was German, and he has retained Germanisms of grammar and orthography which make his method difficult to other modern nations. Before giving the criticisms of linguists, however, we shall briefly describe the leading features of Volapük, this title signifying "world language" in the new method of speech.

Volapük possesses in all 37 letters. To the 5 pure vowels are added the German ä, ö, ü, sounds which very few persons of English, Spanish, or Italian birth are capable of properly making. The consonants, as he arranges them, are b, p; d, t; v, f; h, y, g, k; l, r, m, n; s, j, c, x, z. To these are added 10 new signs, invented or borrowed from existing alphabets, to supply deficient sounds. There are no diphthongs, the vowels have the Continental sounds, and certain of the consonants have arbitrary sounds, c being like j in joy, j like English sh. Thus *jip* is pronounced "sheep."

In forming the vocabulary a basic series of radicals or roots was chosen, these being mostly monosyllabic, with an internal vowel, and one, sometimes two, preliminary and final consonants. Dissyllabic roots are formed on the same principle. The root word is always a noun, concrete or abstract. English being recognized as the most important and widespread language of modern civilization, the roots are taken from it, wherever a suitable one can be found, other languages being used more sparingly. Thus English "man" forms an unobjectionable root. But English "house" is not in accordance with the rule of root formations. So Latin "dom" is chosen instead. "Sheep" is *jip*. Here the pronunciation is preserved, the spelling changed. It is necessary that all roots should begin and end with a consonant, in order that prefixes and suffixes can be readily added as grammatical inflections. The prefixes used are frequently ordinary or abbreviated prepositions. Some are adjectives or shortened nouns of quality. For suffixes *el*, *ik*, *om* are very commonly used. *El* forms nouns which indicate the doer. *Ik* is the termination of all adjectives but the numerals. *Am* corresponds to the English termination "ing" or "tion." *O*, *ü*, and *ö* are used as inflectional terminations. *O* forms adverbs; *ü*, prepositions; *ö*, interjections.

The grammar of Volapük has the modifications of Aryan grammar generally, and forms all these modifications by inflectional expedients. The plural is invariably formed by the addition of *s*, and tenses are formed from units in the same manner. The personal pronoun forms its genders in the third person by the addition of *om*, *of*, and *os*. *Os*, however, is not neuter; all things are masculine; *os* is used only impersonally and abstractly, as *totox*, "it thunders." In nouns denoting person the suffix *ji* makes the noun feminine. In animals *om* denotes the male, *ji* the female. The nominative case is the simple word form. To form the genitive, dative, and accusative *a*, *e*, and *i* are added; in the plural *as*, *es*, and *is*. The preposition governs the nominative except when it denotes motion, then the accusative. Adjectives and participles may be declined when separated from the nouns which they qualify, so that the relation can be shown. The personal pronouns are *oh*, "I"; *oh*, "thou"; *om*, *of*, *os*, "he, she, it"; *om*, "one," or "they," as in "they say." These are attached to the roots to form the person endings of verbs in the indicative, as *penoh*, "I write"; *penoh*, "thou writest"; *penon*, "one writes"; *penohs*, "we write," etc. The signs for the tenses are prefixed vowels, *a* for the present; *ä*, imperfect; *e*, perfect; *i*, pluperfect; *o*, future; *u*, future perfect. Example: *äpenoh*, "I wrote"; *epenoh*, "thou hast

written." The prefix *p* before the tense vowel makes the verb passive, as *patöhsf*, "I am loved." The conditional and subjunctive moods are indicated by the addition of a syllable, *öv* and *lu* respectively, after the person ending, thus: *ähinoböv labik*, if *ähinobla liegik*, signifies "I would be happy if I were rich." The imperative adds *ödl* to the person ending, as *golöloh*, "go thou." The infinitive ends in *ön*, the participle in *öl*, while other prefixes, suffixes, and infixes are employed to cover other exigencies of grammatical inflection.

In forming sentences the words are arranged in the following order: First, the subject; second, the predicate; third, the object. Each principal word is followed by its modifiers, except that adverbs, when modifying adjectives or other adverbs, precede. The negative *no* also precedes the negated verb. This arrangement is a radical departure from the German method, in which the verb is placed at the end of the sentence.

Volapük has grown with some rapidity into favor. It made some progress in Germany and Austria previous to 1884, in which year it was taken up in Holland and Belgium, and in France in 1885. It was introduced into the latter country by Dr. Kerekhoffs, who made several changes, the most of which were decided improvements. Other European nations became interested in it during 1885 and 1886, but little interest was shown in England and in the United States until 1887, since which time much has been written on the subject, text-books published, and classes formed in several cities, though principally among persons of German birth. A convention was held in Munich in August, 1887, the delegates being mostly Germans. At this several simplifications were adopted, a general society of Volapük clubs formed, and an academy established, which began its functions in 1888. Father Schleyer is at the head of both these organizations. Over 100 books on the subject were published in Europe up to July, 1887, and many more have been issued since. Several periodicals in Volapük are now published, and the number of persons who have studied it is given at 100,000. It has been brought into considerable use in commercial intercourse, and has in fact made a remarkable progress, indicating the need of some such international language.

The growing popularity of Volapük has aroused philological students, and several other systems have been proposed since its introduction. In 1885 P. Steiner, of Germany, published a system entitled "Pasilengua," and in 1888 Dr. L. Samenhof, of Warsaw, an "International Language." Both these endeavor to produce a simple, regular system, with a vocabulary formed from existing Aryan words. Dr. Samenhof is credited with excellent judgment in his selections, and the vocabulary of both can be acquired with great ease, yet both use diacritical marks, sounds not common to all Aryan tongues, and grammatical complexities. The method proposed by Dr. Samenhof closely resembles that in use in the "agglutinative family" of languages. More recently, A. Melville Bell, the author of the system of "visible speech" for deaf mutes, has proposed what he calls "World English," based on the fact of the wide employment of English. It is simply English written on a phonetic system, with certain new consonantal signs and a simplification of English grammar.

The advantages of Volapük are given by the *Saturday Review*, as the following. Its words present no accumulation of heaped-up consonants or vowels, and there are no long compound words. It has no arbitrary rules of orthography, sparingly uses difficult sounds, and greatly decreases the number of words by its free use of inflections. This renders it useful for telegraphy. It is marked by clearness and precision, and freedom from ambiguous forms, while its numerous rhymes adapt it well to versification. It is

richer in forms than almost any other living language, and allows greater latitude in the construction of sentences. Yet it is not free from exceptions, such as that in which the preposition governs *mostly* the nominative. Exceptions of accent are also allowed in poetry.

The advantages above named are correlated with faults which must stand in the way of its general acceptance by Aryan nations. These faults have been pointed out by a committee of the American Philosophical Society appointed in 1887 to consider and report upon the newly proposed language. The report of the committee is shrewd and sensible in its suggestions, and we give an abstract of it, as showing the views of many linguists as to what a world language should be. The committee had for its chairman Prof. D. G. Brinton, the distinguished archæologist, the other members being Henry Phillips, Jr., and Monroe B. Snyder. They expressed the opinion that a universal language is greatly needed for the use of scientists, and also for the commercial and travelling world, but much less so for general literature, and that if adopted it is likely to be used as an addition to the native language of each people. Their report contains the following suggestions: 1st, the orthography of such a language should be absolutely phonetic; 2d, every letter should have but one sound; 3d, this sound should be common to all the leading Aryan languages; 4th, diphthongs, double consonants, etc., should be omitted; 5th, the meaning should never depend on tone, accent, quantity, or inflection of the voice; 6th, the vowels should be limited to the five pure vowels a, e, i, o, u, with the Italian pronunciation (these being common to all Aryan tongues); 7th, in consonants, all gutturals, aspirates, lisps, and nasals should be omitted, and all double and complex consonantal sounds; 8th, diacritical marks, accents, and apostrophes should be omitted, and all signs that cannot be made without lifting the pen (as the crossing of the t and the dotting of the i) avoided; 9th, all sounds should be easy to make and agreeable to the ear; 10th, brevity should be sedulously sought.

The vocabulary should be based on that common to the leading Aryan tongues. There are 1500 words in German almost the same as in English, and more than this common to English, French, Spanish, and Italian. At least a thousand words are common to all these languages, their main difference lying in pronunciation. Commercial, business, and scientific terms have much in common, the chief differences occurring in literary and art terms. The most important differences, and the least easy to obviate, are those between the grammatical forms of the several languages. In respect to grammar, the simplest method is the best. In a simplification of grammatical forms the interjection and article might be dispensed with. Several languages find no need of the latter. The adjective has neither gender, number, nor case in English, yet no difficulty arises in consequence, and therefore these modifications could be dispensed with. The distinction of form between the adjective and adverb might be omitted, as it often is in the spoken language. This would reduce the present nine parts of speech to six.

The comparison of adjectives by "more" and "most" is now practically the rule in the Romance languages, and might be generally adopted. The noun has no gender in English and modern Persian, though useless and annoying gender inflections are retained in all other Aryan tongues. The adjective of sex serves all necessary purposes of indicating gender in English. Number also could be usually dropped, as is now occasionally done. Case might be omitted. English retains only the genitive. Case can be readily replaced by pronouns and prepositions, as the genitive by the old use of "his" as in "John his book." Relative, interrogative, and demonstrative pronouns could be blended without confusion. The reflexive form is unnecessary, as is shown by English usage. In verbs all inflections

can be avoided by the use of auxiliaries, and the modern development of language has tended strongly in this direction. Most prepositions could be omitted by the arrangement of the sentence into verb, direct object, and indirect object. This simplification would yield an equal simplification in syntax, but would be attended with a loss to the flexibility of language. The logical arrangement of the sentence should be: the subject before the predicate; the noun before the adjective; the verb before the adverb; the immediate before the remote object. Internal inflection, and the use of prefixes, infixes, and suffixes should be avoided.

These suggestions, which are based on the tendencies manifested in the evolution of languages, and particularly of modern English, which has divested itself of the old inflectional methods more fully than any other modern language, are applied to the system of Volapük, which, as weighed in this balance, is found seriously wanting. It is, in the opinion of the committee, in conflict with the development of the Teutonic and Romance tongues alike, and is full of difficulties to the learner. It retains the impure German modified vowels, the French j and the aspirate h, and has 8 vowels and 19 consonants, where 5 vowels and 16 consonants would suffice. It has various diacritical marks of accent, tones, inflection, and quantity (all needless obstructions). Double consonants are numerous, and vowels are printed and written with underscoring and Italic letters to facilitate the comprehension of words. Several of the sounds used could not be pronounced by an Aryan without special oral training. Many words are manufactured from entirely new radicals, capriciously formed. Nouns are inflected through four cases, prefixes and suffixes commonly used—all this being out of accordance with the tendency of Aryan speech development. There is an excessive multiplication of inflectional forms; verbs are modified by 14 prefixes and 16 suffixes, and the meaning of a word largely depends upon its place in a sentence. The system of Volapük, in short, is absolutely opposed to the evolutionary tendencies of Aryan speech; it being synthetic and complex, while all modern dialects are growing more and more analytic and simple. It proposes a distinct retrogression in linguistics, a step backward toward conditions from which we have been for centuries escaping.

The committee, in conclusion, recommended the calling of a congress of philologists, for the purpose of devising an international language of the simplest and most advanced character possible, not for the purpose of supplanting existing tongues, but to add to them a general medium of international intercourse, and a common scientific and commercial language. In compliance with this recommendation the American Philosophical Society has taken steps to call together such a congress, composed of the most capable philologists of Europe and America, and it seems very probable that the instigation of Volapük will lead to the formation of a world language in every respect in harmony with the present state of the science and fully adapted to the needs of international intercourse.

(C. M.)

VOWS AND OATHS. In our English versions of the Bible the phrase "God forbid" (as distinguished from "the Lord forbid," p. 309 (p. 320 or "my God forbid") occurs eight times in the Old Testament, and fifteen times in the New Testament. Neither the Hebrew nor the Greek phrase so translated contains the name of the Supreme Being, either expressly or by implication. The phrase "God save the king" occurs eight times; in each case the Hebrew is simply "Live the king." We are in these cases accustomed to translate the Hebrew or Greek phrases, not by English words that correspond with the words of the original, but by English idiomatic phrases that are conceived of as conveying, on the whole, the same meaning with the original, and these English phrases came into the language

from other than Biblical sources. These peculiarities of translation have something of a typical character. In the matter of appeals to the Supreme Being, either in oaths or vows, the ideas of Christian peoples are more or less colored by notions of heathen origin. This appears in our current religious phraseology, our hymnology, our interpretations of Scripture.

The fundamental law concerning vows is stated in Deut. xxiii. 21-23. They are often mentioned in connection with freewill offerings, with which they have this in common, that they are required from no one; the law simply regulates them, in case any one deems it a privilege to offer them. But the limits within which the vow is permitted are narrower than those of the freewill offering. For example, no vow to offer an animal in sacrifice is permitted, unless the animal is without blemish. When a vow has once been legally made the legal accomplishment of it is rigidly exacted. But it is evident that the vow was commonly thought of rather as a form of prayer, or of public confession and thanksgiving, than as a bond upon the person making it. This is strikingly illustrated by the fact that the current word for it in the Septuagint and the New Testament is *εὐχή*, prayer, while the most common variants are other forms of *εὐχόμεαι*, and the word *ὁμολογία*, signifying public confession. The interpretation thus given to the Old Testament word fits its use as far back as this can be traced. It follows from this that vows are not presented, in the Bible, as modes of bribing the Supreme Being for his interference, or of paying him for favors, but rather as a method of prayer and an expression of praise and gratitude.

The Biblical vow is ordinarily a promise to offer some sacrifice, or perform some ritual act, or render some other external service. The services vowed are always external, and ordinarily temporary, not spiritual or perpetual, though of course the spirit with which a vow was performed was regarded as all important. The law of the devoted things, Lev. xxvii. 21-29, Num. xviii. 14, cf. Josh. vi. vii., is not an exception to this statement, for the "herem" is a different thing from a vow. The case of the Nazirite for life is not an exception, as we shall presently see. The case of Jacob's accepted vow, Gen. xxviii. 20-22, xxxi. 13, is not an exception, for the words "Jehovah will be to me for God" properly close the protasis of the sentence, instead of beginning the apodosis. Jacob did not vow that if Jehovah would go with him and supply his wants and bring him back, then Jehovah should be his God, but that if Jehovah, fulfilling the promises he has just made to be with him and bring him back, would be his God (verses 13-15, cf. xvii. 7), then Jacob would make his memorial stone a house of God, and would give tithes.

The article in the ENCYCLOPEDIA BRITANNICA mentions the prominence given in the Roman Catholic Church to irrevocable vows of certain sorts. Solemn promises made to God, having something of the nature of vows, are quite common among Protestants. To say nothing of Brotherhoods and Sisterhoods, formed more or less upon the Roman model, we have the solemn promises made by ministers at licensure or ordination, those made by ministers and people at the institution of the pastoral office, those often made at the receiving of persons into covenant with the church, the pledges of the various Christian Associations, Christian Endeavor Societies, Temperance Societies, and many others of the same general character. As to all such matters, it should be remembered that while a pledge of this kind, used within Scriptural limits, may be a privilege and a help, there is great danger of our making it the contrary. If we permit vows of this kind to take the place in our lives that belongs to love or conscience or the grace of God, the vow will become a burden and a snare.

From the point of view of those who regard the Biblical account of the origin of the Mosaic legislation

as historical, the vow of Jephthah, Jud. xi., must be regarded as illegal. He had no right to vow a burnt-offering to Jehovah, except as he limited the vow to animals legally fit for that purpose. We have here an account of a rash man who had military gifts and who was used by Jehovah, but whose religious position by no means indicates the true character of the religion of Jehovah at that period. There is nothing to show that either Jephthah's vow or that of Hannah, 1 Sam. i. 11, were cases that would fall within the law of redemption given in Lev. xxvii., and there is therefore nothing in these cases to show that that law was then non-existent. Instead of saying "the principle that a vow once taken must be fulfilled at any cost was so far modified in later times in Israel that exceptional vows were by law redeemed at a valuation," it would doubtless be correct to say that from the times of Moses the law provided for a class of vows that might be so redeemed.

In the article NAZARITE or NAZIRITE, in the ENCYCLOPEDIA BRITANNICA, it is asserted that "the Hebrew root N-Z-R is only dialectically different from N-D-R, to vow." This is in one sense true, but not in the sense that would justify the inference "that the peculiar marks of the Nazirite are primarily no more than the usual sign that a man is under a vow of some kind." Any one will be convinced of this who will notice the distinctness with which the two words are used in Num. vi., and throughout the Old Testament. Whatever might supposedly be true of the two words, if they belonged to different dialects, it is a matter of fact that in Hebrew usage they are sharply differentiated.

The statement that the law of the Nazirite, as found in Num. vi., "is not pre-exilic," is, of course, contrary to the explicit testimony of Num. vi. 1, which attributes the law to Moses. Very likely it may be true that this law is "directed to the regulation of a known usage," but there were already such things as existing usages in the times of Moses. Further, the fact that the law contemplates one form of Nazirite usage does not render it incredible that other forms of it may have existed. The case presented in Num. vi. is that of a temporary Nazirite usage by vow; the case of Samson (perhaps that of Samuel also) is the different case of a person who is a Nazirite for life by divine appointment, independent of any vow made by himself. If we regard these cases as two species of a common genus, then the fact of the existence of one species in the times of the judges indicates the probable existence of the other species rather than proves it to be non-existent in those times. And in any case, the variations between the case of Samson and the description given in Num. vi. have no weight to prove that the law in Num. vi. had not then been given; for the variations may either be due to the difference between the condition of a Nazirite for life and a Nazirite for a limited period, or may be accounted for like the other prevalent negligences and irregularities in the observances of the national laws that were prevalent in the times of Manoah and Eli. (W. J. B.)

VULPIAN, EDMÉ FÉLIX ALFRED (1826-1887), French physiologist, was born at Paris, Jan. 5, 1826. In 1854 he graduated at the Medical School, and becoming assistant in the Museum of Natural History pursued researches on the nervous system. In 1867 he was, despite of the charges of materialism made against him by the bishop of Sura, called to the chair of pathological anatomy in the Medical School. In 1868 his teachings were attacked during the discussion of a petition against the instruction in that school, but Vulpian maintained an attitude of such dignity that he acquired the esteem of the scientific world, and in the next year was made member of the Academy of Medicine. In 1872 he passed to the chair of experimental and comparative pathology, and in 1875 was made dean of the faculty. In 1876 he was chosen member of the Academy of Sciences. By his

erudition and the strictly scientific methods evinced in his researches on the nervous system he attained to the first rank among physiologists. He died at Paris, May 18, 1887. His important works are *Des Pneumonies secondaires* (1860); *Leçons sur la Physiologie générale et comparée du Système nerveux* (1866), the

work which founded his reputation; *Leçons sur l'appareil vaso-moteur* (2 vols., 1875), in which he subjects previous works to the rigid tests of experimentation; *Clinique médicale de l'Hôpital de la Charité* (1878); *Maladies du Système nerveux* (1879).

(J. W. W.)

W.

WACE, HENRY, English clergyman and author, was born in London, Dec. 10, 1836. He was educated at Brasenose College, Oxford, and graduated B. A. in 1860. Having taken orders he was curate in London from 1861 to 1869, and chaplain of Lincoln's Inn from 1872 to 1880. He was also professor of ecclesiastical history in King's College, London, from 1875 to 1883, and since that date has been its principal. He has also been prebendary in St. Paul's Cathedral since 1881, and has been select preacher at the universities of Oxford and Cambridge. He has published *Christianity and Morality*, Boyle lectures (1876); *The Foundations of Faith*, Bampton lectures (1880); *The Gospel and its Witnesses* (1883); *Student's Manual of the Evidences of Christianity* (1886). With Dr. William Smith he edited the valuable *Dictionary of Christian Biography* (4 vols., 1880-86). This work treats with scholarly fulness and accuracy of the literature, sects, and doctrines, from the time of the apostles to the age of Charlemagne. Dr. Wace is the author of the *Commentary on the Apocrypha* (1886) in what is called the *Speaker's Commentary*. He has been associated with Prof. Buehheim in editing the *First Principles of the Reformation* (1884).

WADDINGTON, WILLIAM HENRY, French archæologist and statesman, was born of English parents, Dec. 11, 1826, at Saint-Remi (Eure-et-Loire). His education was commenced in Paris, and completed at the University of Cambridge. Thence he returned to France, and chose it for his nationality. Possessed of fortune, he gave himself to antiquarian and numismatic pursuits, and became member of the Society of Antiquaries. The results of a journey in 1850 in Asia Minor, which he published in two *Memoirs*, were crowned by the Academy of Inscriptions, of which institution he was chosen a member in 1865. Elected from the department of Aisné in 1871 to the national assembly, he soon obtained note by his report of the law for the organization of the councils general. At first he ranked himself with the right centre, but, after his brief occupancy of the post of minister of public instruction for five days in May, 1873, at the end of M. Thiers' presidency, Waddington generally voted with the left centre. He gave his vote for the law which restricted the right of suffrage till the age of twenty-five. In May, 1874, after the fall of the Duc de Broglie, he declined a portfolio in the new cabinet; voted against the law for freedom from state control in higher instruction, and supported the Republican constitution. He was elected senator from Aisné in 1876, but very soon in the Dufaure cabinet took the position of minister of public instruction, from which the department of public worship was then separated. He enforced compulsory primary education and the governmental control of all educational institutions. In the department of higher instruction he aimed at the grouping of the faculties in the powerful and complete universities, the establishment of private courses of study directed by the faculties, the development of libraries, laboratories, and collections, and urged the creation of scholarships for poor students. He changed some colleges into lycées, instituted faculties of law at Bordeaux and Douai. He retained his portfolio when Jules Simon became premier, but resigned

it five months afterward (May 16, 1877), and in the next month he voted in the senate against the dissolution of the chamber of deputies. In the following December he entered the new cabinet of Dufaure as minister of foreign affairs. He acted as the French plenipotentiary at the congress of Berlin (June, 1878), and claimed for Roumania and Servia freedom of religion and political equality, conformably to the law of modern civilization. He stoutly insisted on the rectification of the boundaries between Greece and Turkey. On his return to France he announced to his government its honorable re-entry in the councils of the great powers, and was complimented by M. Dufaure in a public letter. After Marshal MacMahon's resignation of the presidency and Dufaure's retirement, Waddington, under the presidency of M. Grévy, while retaining the ministry of foreign affairs, accepted in February, 1879, the presidency of the council. He was then antagonized by the senate as too republican, and by the chamber as too moderate. Notwithstanding, he protested against the prosecution of the late ministry of MacMahon on the one hand, and on the other against an entire amnesty. Despite the dissatisfaction of a portion of the Republicans of the chamber, he obtained a vote of confidence, Dec. 2, 1879. But four weeks later he resigned both his positions, whereupon he was offered the ambassadorship to England, which he declined. Besides the *Memoirs*, mentioned above, he has written *Mélanges de Numismatique et de Philologie* (1861); *Édit de Dioclétien* (1864); *Voyage archéologique en Grèce et en Asie Mineure* (1868-77).

WADE, BENJAMIN (1800-1878), senator, son of a soldier of the Revolution, was born near Springfield, Mass., Oct. 27, 1800. The family was in very humble circumstances, and what the boy learned was from his mother. In 1818 he migrated to Northern Ohio, and supported himself by farm-work, and driving cattle to New York, with intervals of teaching school and shovelling on the Erie Canal. He managed to study law, began practice in 1828, and after the usual waiting for clients was made prosecuting attorney of Ashtabula county in 1835. In 1837 he was sent to the State senate, where he was soon known as an outspoken opponent of the slave system and its concomitants in the North. Popular opinion on this subject in Ohio was not then what it afterward became, and Wade's hostility to the State "black laws" incurred such odium as relegated him to private life. After his re-election he had charge of the bill which incorporated Oberlin College. He became president judge of the Third Ohio district in 1847. The dignity of the bench did not repress his political activity; after the sessions of his court he made speeches in the campaign for Taylor, whom, though a slaveholder, he preferred to Van Buren. His reputation was no more than local when he was sent to the U. S. Senate as a Whig in 1851; but in the national arena he speedily made himself felt, and was a striking figure for eighteen years. A hearty hater, with the full courage of his convictions, untroubled by delicate scruples, consideration for opponents, or the philosophic habit of looking at both sides, he was in his element in the rude struggles which preceded the conflict of arms. His

rough and ready frankness and immovable determination were a set-off to "plantation manners," and he was of use in making felt the ripening Northern will and purpose, where more refined men and measures might have failed. When challenged by a Southern Senator, he so conducted himself as to bewilder and overawe his adversaries. His rebuke to Douglas, during the debate on the Kansas-Nebraska bill, however unparliamentary, was effective. He earned the respect of Toombs, who bore public witness to his manly sincerity and directness. With five others he voted in 1852 to repeal the Fugitive Slave law. He opposed the Leecompton constitution for Kansas, the proposed purchase of Cuba, and every measure in the interest of slavery. He advocated negro suffrage in the District of Columbia; and pushed the Homestead bill till it was passed in 1862. He earned the familiar appellations of "honest Ben Wade," "the old Roman," and the like. The war he may be said to have enjoyed, urging emancipation and confiscation from the start, and as chairman of the Joint Committee on its conduct rendering real service. To the era of reconstruction he was ill adapted, for moderation and mercy were neither in his views nor in his temper. He opposed a second term for Lincoln, and as president of the Senate vehemently urged the impeachment of Pres. Johnson. Counsels of this kind had not a happy effect when the war was over, a fact which he seemed unwilling to realize. By 1869 he was no longer needed in the Senate, nor was he invited to the Cabinet, but his retirement was softened by a commissionership on the Pacific Railroad. In 1871 he was on the Santo Domingo Commission, and favored annexation. He was last heard of in 1877 as violently opposing the mild policy of Pres. Hayes toward the South. An ardent reformer while the battle of principles was in progress, he could not accept results and be content when the victory was won. He died at Jefferson, Ohio, March 2, 1878. See his *Life*, by A. G. Riddle (1886.)

WAGES. See AGRICULTURE, Chap. X., LABOUR and STRIKES.

WAITE, MOURSON REMICK (1816-1888), chief-justice of the United States, was born at Lyme, Conn., Nov. 29, 1816. Having graduated at Yale College in 1837, he removed to Ohio, where he completed his legal studies and engaged in the practice of the law at Toledo. He filled no national office until selected by Pres. Grant in 1872 to represent the United States at Geneva before the tribunal of arbitration on the Alabama claims under the treaty of Washington with Great Britain. While presiding over a convention for the revision of the constitution of Ohio he was nominated by Pres. Grant to the office of Chief-Justice of the Supreme Court of the United States, and entered on its duties March 4, 1874. He held that office until his death, which occurred on March 23, 1888.

Prior to the sickness that terminated his life he had prepared an elaborate opinion in the telephone cases that had been for many months before the Supreme Court involving the validity of the Bell telephone patents. Before he had obtained entire relief from the indisposition which had affected him he took his place upon the bench, on March 19th, for the purpose of delivering the judgment of the court in the telephone cases. He remained in court while the opinion was read by another and then returned to his bed, from which he never arose.

Chief-Justice Waite was called to preside over the Supreme Court at a period that marks one of the great stages in the history of that court. The rebellion of 1860 had been suppressed and the period of reconstruction had passed, during which the powers of the government had been strained to meet the exigencies that threatened the national unity if not its existence, and it now devolved upon the court over which he presided to readjust the civil relations that had been disturbed during this exciting period in conformity with sound views of the nature and limitations of

the public authority. In a political sense the period under consideration was necessarily one of conservative reaction and it was to be anticipated that the action of the court would reflect that tendency. The vast increase of business transacted by the court was another peculiar feature of this period, and a relatively large proportion of that business related to public and corporate obligations. The war had given a great impetus to the extension of railways, connecting together all parts of the country from the Atlantic to the Pacific and from the Lakes to the Gulf, and the adjustment of the legal relations arising from such interests brought to the court an extended and complicated branch of business. The crowded state of the calendar of the court rendered the despatch of business the most pressing necessity of the conduct of its business.

In the early years of the Supreme Court, when the structural lines given by the Constitution were to be transferred to the institutions and habits of intercourse of a young and growing society, and that court was the organ of such adjustments, and when the national impulses and local predilections of men read the purposes of that Constitution in opposite senses, a mind comprehensive and exact, animated by the genius of our national institutions and sensitive to the balance of our complicated legal system, was needed in the chief seat of that court to inspire and mould its deliberations, and that mind was found in John Marshall (for whom see ENCYCLOPEDIA BRITANNICA). The occasion was great and the man was equal to the demand of its exigencies. Before that day nations had arisen and become great under the arbitrament of the sword, but the spectacle of a nation planned in council and habituated under the genial sway of judicial reason was new to the world.

As the first great period in the history of the court demanded an idealty that could grasp the possibilities of American civilization, so the second period demanded a robust administration to give fibre to that which had been fashioned by his great predecessor. The court over which Chief-Justice Taney (*q. v.*) presided did not fail to meet what was promised by its ability and demanded by the state of the country, until the dark shadow of the rebellion of 1860 disturbed its equanimity.

The third great period may be regarded as commencing at the accession of Chief-Justice Waite to its first office. The necessity for settling great fundamental political questions appeared to have passed, and the early doctrines of the court had passed into full acceptance and had been clearly illustrated and defined. The industrial development made the chief demand upon the attention of the court. Commercial enterprises embodying the national spirit that emerged with fresh animation from the unities of purpose and action brought about by the war passed from local to interstate relationships, thus widening the area of federal jurisdiction and crowding the court with a great volume of business that overtasked its means of discharging such grave public duties. Under such circumstances an able administrator was what was needed at the head of the court and such an officer was found in Chief-Justice Waite. With the depressing fact ever present in the mind of the court that its suitors must wait three years to be heard before it, it is not surprising that the adornments of oratory should largely disappear from the court, replaced by frictionless machinery without heat or scintillation. The mental constitution of Chief-Justice Waite was not at variance with the necessities that thus affected the court, for he regarded it as a place for the transaction of business and its chief duty beyond that of deciding properly to be the expedition of its business. If the overtasked powers of the bench did not admit of the realization of the forensic models of Rome and Greece that was on deprivation to the Chief-Justice, who entertained English ideas of methods of advocacy. A concise and

clear statement of facts and a skeleton of an argument emphasized at its salient points satisfied in his mind the demands of the duty of the advocate and the convenience of the court.

It often happens that the advocate in the course of examining a proposition of law under its limited application to a case under consideration sees it in its broad relations, and thus obtains a standpoint from which its specific applications can be most accurately judged. In such cases it is natural that he should endeavor to lead the court to the same standpoint, and if the prevailing methods of presentation and the state of business in the court do not admit of such an effort it is a grave misfortune. Whenever our jurisprudence reaches the last term of its development, it will be possible to administer it by mechanical methods, but so long as it is to meet new conditions and exhibit expansive qualities the required conditions must be found in the methods and mind of the court. A close adherence to English forensic methods is not practicable for the mind or conditions of America. The English jurists adhere to antecedent forms and draw their reasonings from limited authoritative sources, avoiding generalizations that embrace elements that have not this technical sanction; while the American jurist recognizes that the conditions of our national life demand progressive changes, and he seeks to conserve substance rather than form as derived from the past, and admits the principles of nature and social order into his generalizations although not recognized by his juridical predecessors. The English jurist aims to perpetuate existing forms of legal institutions, while his American brother looks to higher adaptations of existing methods than have yet been reached.

Under the tendency that has just been stated American constitutional law has sprung into existence, which owes its development to a breadth of generalization excluded from English forensic methods. It may be said that the stage of the expansive development of American jurisprudence has passed, and it may be true that the most active period in that respect has gone by, but there is nothing in retrospect or forecast to warrant the opinion that a stage of development has been reached that will impose on the jurists of this country no more arduous duty than that of conserving its forms and principles.

Chief-Justice Waite possessed that trained legal sense, by which conclusions are drawn before the reasons on which they rest are consciously recognized, and which is the first condition of a sound legal judgment. This quality apprehends the fitness of things in a legal sense before their details are examined, and is in fact a generalization based on broad legal experience without which legal inquiry is in danger of being lost in technicalities and minutiae. If confidence in the possession and value of this quality sometimes disinclines its possessor to painstaking efforts for the verification of his results, on the other hand its absence or weakness leaves opinion without anchorage in the sense in which the term opinion is put in contrast with that of conviction. In the scientific branch of legal work, which consists in testing the generalizations drawn in the manner just pointed out by the results of antecedent judicial decisions, many have surpassed Chief-Justice Waite, and the same may be said as to that rare quality by which legal principles are unfolded in their nature and applications.

In his personal bearing as a judicial officer Chief-Justice Waite was kind and considerate, and, although the flowers of rhetoric did not flourish under his touch, kindly feelings habitually remained with those who had judicial intercourse with him.

See "Memorial Proceedings in Supreme Court," *U. S. Reports*, Vol. 126, Appendix. (A. J. W.)

WALKER, AMASA (1799-1875), economist, was born at Woodstock, Conn., May 4, 1799; his ancestry settled at Charlestown, Mass., 1641. From 1825 to 1840 he was engaged in business in Boston, and active

in the temperance and anti-slavery movements. From 1843 his home was at North Brookfield, Mass., but for some years he visited Oberlin, Ohio, as professor of political economy. He was sent to the Massachusetts assembly 1848 and to the senate 1849, was secretary of state 1851-2, member of the Massachusetts Constitutional convention 1852-3, of Congress 1862-3, and lecturer on political economy at Amherst College from 1861. He died Oct. 29, 1875. He was one of three editors of the *Transactions* of the Massachusetts Agricultural Society, 1848-54. He wrote much on his favorite subject for periodicals, and published *Nature and Uses of Money* (1857), and *Science of Wealth* (1866). The latter was widely read, and gained much repute and influence.

His son, FRANCIS AMASA WALKER, statistician and educator, was born in Boston, July 2, 1840, and graduated at Amherst College in 1860. His legal studies were interrupted by the war, in which he became adjutant-general of Gen. D. N. Conch's division in 1862, and colonel in 1863. He was wounded at Chancellorsville, taken prisoner, and emerged from the strife with broken health and the brevet of brigadier-general. After teaching for two years at Williston Seminary, Easthampton, Mass., and editing the *Springfield Republican* for a year, he was appointed chief of the bureau of statistics at Washington 1869, superintendent of the Ninth Census 1870, and Indian commissioner 1871. He became professor of political economy and history in the Sheffield Scientific School of Yale College 1872, and president of the Massachusetts Institute of Technology in Boston 1881. Besides three volumes of census reports and a *Statistical Atlas of the United States* (1874), he has published *The Indian Question* (1873); *The Wages Question* (1876), *The World's Fair* (1876); *Money in its Relation to Trade and Industry* (1879); *Political Economy* (1882), in the "American Science Series"; *Land and its Rent* (1883), and *History of the Second Corps, Army of the Potomac* (1886).

WALKER, ROBERT-JAMES (1801-1869), statesman, was born at Northumberland, Pa., July 19, 1801, and graduated at the University of Pennsylvania 1819. He began to practise law at Pittsburg 1819, became an active Democrat, and removed in 1826 to Natchez, Miss., where he rose to prominence. Always a Unionist, he resisted the nullifiers in 1833. The next year he published *Reports of Cases in the Supreme Court of Mississippi* (1818-32). Elected to the U. S. Senate 1836, he introduced the earliest Homestead bill, supported Van Buren's measures, and urged the recognition of the independence of Texas in 1837, and afterwards its annexation. He had much influence with Pres. Tyler, and helped to effect the nomination of Polk, who made him secretary of state in 1845. In this office he actively favored free trade, procured a reciprocity treaty with Canada, and introduced the warehousing system. The Department of the Interior was established at his suggestion. His later posts were of less eminent rank, but afforded opportunities of honorable service. In 1853 he was a commissioner to open commercial relations with China and Japan. In 1857, as fourth governor of Kansas, he repeated the dolorful but enlightening experiences of his predecessors (Reeder, Shannon, and Geary), and declared himself "unwilling to aid in forcing slavery on Kansas by fraud and forgery." As in this case he broke with Buchanan's administration and the slave power, so in the war he would not go with his adopted section. As U. S. financial agent in Europe during most of 1863-4, he negotiated \$250,000,000 of the 5-20 bonds, and prevented the sale of the second Confederate loan of \$75,000,000. During these years he edited the *Continental Monthly*, and wrote for it some letters on American resources, which exerted an influence abroad and won high praise. He advocated the purchase of the Danish West Indies and Alaska, and the construction of the Pacific Railroad. As a friend of peace and of both sections, he

opposed the impeachment of Pres. Johnson, and the carrying out of the Congressional Reconstruction measures in Mississippi. He died Nov. 11, 1869, at Washington, where he was prominent at the bar.

WALKER, WILLIAM (1821-1860), filibuster, was born at Nashville, Tenn., May 8, 1824. After traveling abroad, studying medicine in Paris, and being admitted to the bar, he was connected for a time with the New Orleans *Crescent* and the San Francisco *Herald*, and practised law at Marysville, Cal. In October, 1853, he undertook a fantastic enterprise against the north-western states of Mexico. Landing with a few comrades at La Paz on the end of the Californian peninsula, he proclaimed himself president of the country, "annexed" Sonora, and marched northward, only to surrender at San Diego. In May, 1854, he was tried at San Francisco for a violation of the neutrality laws and acquitted. Invited to Nicaragua, he landed at Ruelijo in June, 1855, raised a force, won in a few actions, took Granada, Oct. 15, and executed a native general for "treason." In a war with Costa Rica he retrieved a defeat in March, 1856, by a victory in April. "Elected" president in June, he issued currency on a large scale, re-established slavery, and was recognized by Pres. Pierce. His intrusive tyranny provoked a revolt, and the opposition of the Vanderbilt Steamship Company, whose property he had confiscated, contributed to his downfall. After burning Granada, he surrendered May 1, 1857, to Commodore C. H. Davis, and was sent to New Orleans, whence he escaped to make another effort, but within two weeks was taken by another U. S. naval officer, and conveyed to New York. His madness was encouraged by sympathy at home, and Pres. Buchanan ordered his release in January, 1858. In the fall he started again, but was arrested, tried in New Orleans, and acquitted. His curiously unamiable fanaticism despised all lessons of experience, and in June, 1860, he landed at Truxillo, in Honduras. Two months later he was driven from the town by a British war-vessel; marching into the country with a small force, he was captured by the native authorities, and shot Sept. 8, at Truxillo. He represented no American or rational principle, and accomplished no good end: his reckless exploits belong rather to mediæval than modern manners, but he is unregretfully remembered as "the gray-eyed man of destiny," and the chief of "filibusters." His account of *The War in Nicaragua*, written before his last expedition, appeared at Mobile, 1862.

WALLACE, ALFRED RUSSET, an eminent English naturalist, was born at Usk, Monmouthshire, Jan. 8, 1822. He received his education at the grammar school of Hertford, and was articled to an elder brother who pursued the business of land surveyor and architect. Early in life, however, he gave up this pursuit in favor of the study of natural history, and in 1848 accompanied the naturalist Henry Walter Bates on a scientific expedition to Brazil. They made a long sojourn in Pará, engaged in a scientific exploration of the vicinity, and then started on a voyage of exploration of the forest region of the Amazon and Rio Negro rivers, from which they returned to England in 1852. During this journey Wallace obtained a somewhat extended vocabulary of the Indian languages of the Amazon valley, and a valuable collection of scientific material, which was very rich in the departments of botany and ornithology. Unfortunately, the greater part of this was lost in a shipwreck. In 1853 he published *Travels on the Amazon and Rio Negro, with Remarks on the Vocabulary of the Amazonian Languages*, which work was followed by *The Palm Trees of the Amazon, and their Uses*.

In 1854 he set out on a yet more important scientific journey, the field of his exploration being now the islands of the Malay Archipelago, in which region he remained for eight years, passing from island to island, and extending his expeditions to the island of

New Guinea, then almost unknown for scientific purposes. This long period Wallace occupied in the most ardent and enthusiastic natural history labors, resulting in the collection of an extraordinarily rich cabinet of zoological specimens, including more than 100,000 insects and over 8000 birds. Among his special studies were the habits of the orang utan, and, while in New Guinea, the birds of paradise, peculiar to that island. To him we owe the earliest satisfactory account of the habits and haunts of this most beautiful family of birds. He succeeded in adding to those already known a new species, the Standard Wing (*Semioptera Wallacei*), distinguished by a pair of long, narrow white feathers, springing from the bend of the wing, and capable of being erected at the bird's pleasure. While thus engaged his mind was also occupied with the study of the mystery of the origin of species which has during the present century exercised the intellects of so many able naturalists. The result of his thoughts was the conception of an idea of animal derivation remarkably similar to Darwin's celebrated theory of natural selection, and the parallel is the more interesting from the fact that the announcement of the results of Wallace's and Darwin's studies was made on the same day and before the same scientific body. Wallace embodied his theory in a paper entitled "On the Tendency of Varieties to depart indefinitely from the Original Type," which he sent to the Linnæan Society through Sir Charles Lyell. It was read on July 1, 1858; and at the same meeting was read Darwin's paper "On the Tendency of Species to Form Varieties, and on the Perpetuation of Species and Varieties by means of Natural Selection," which contained the first public statement of his celebrated theory. Wallace recognized natural selection as the agent in producing most of the changes pointed out by Darwin, but denied its sufficiency, without aid from some higher power, to explain the origin of the human species. Though the two naturalists arrived at this theory independently of each other, the priority has been given to Darwin, who had privately described his theory to scientific friends several years before, had conceived it many years previously, and published a detailed exposition of it immediately after the first public announcement, with a wealth of illustrations, the results of his own studies, far in excess of anything that Wallace had to offer.

In 1862 Wallace returned to England, where he spent several years in arranging and classifying his vast collection and in writing a popular account of his explorations, which was published under the title of *The Malay Archipelago, the Land of the Orang-utan and the Bird of Paradise* (1869), and ranks among the most entertaining and instructive narratives of scientific exploration. He also published many papers in the proceedings of the Linnæan, Zoological, Ethnological, Anthropological, and Entomological Societies, a collection of which was issued in 1870, entitled *Contributions to the Theory of Natural Selection*. In 1868 he received, in acknowledgment of the high value of his scientific labors, the gold medal of the Royal Society, and in 1870 the gold medal of the Geographical Society of Paris. The works above named were followed in 1876 by the most valuable of his scientific productions, an elaborate work *On the Geographical Distribution of Animals*, which was issued in English, French, and German, and yet remains the standard work on the subject. In the same year he was president of the Biological section of the British Association in its meeting at Glasgow. His other scientific works comprise *Tropical Nature* (1878), which contains his latest views on the colors of natural objects, sexual selection, geographical distribution, etc.; and *Island Life* (1880), in which he considers the phenomena presented by the faunas and floras of the principal islands of the globe and the problem of geological climates. He has also edited a work on *Australasia*, chiefly written by himself. In 1882 he

received from the University of Dublin the honorary degree of D. C. L.

Wallace's attention has not been confined to scientific subjects. After his return from the Pacific islands he gave much attention to the phenomena of spiritualism, into which he made close researches, with the result of becoming firmly convinced that they were actually the work of disembodied spirits. The results of his observations in this direction were published in 1874 in a series of essays in the *Fortnightly Review*, which were afterwards reprinted under the title, *Miracles and Modern Spiritualism* (1875). Since that date Wallace has written little upon the subject, but is said to be still a firm believer in the spirit origin of these phenomena. At a later date he became strongly interested in social and political problems, and published *Land Nationalization, its Necessity and Aims* (1882), in which he gave a sketch of the whole subject of the tenure of land, and proposed a scheme of occupancy under state control which he believed would remedy the numerous evils of the present system of land-holding. For the advocacy and promotion of this scheme a Land Nationalization Society has been formed, with Wallace as its presiding officer. A later economic publication is his *Bad Times, with Suggested Remedies* (1885).

As a scientific thinker and observer Wallace occupies a high position in the annals of modern science, yet in the former has not attained the standing to which his mental acumen seems to entitle him. Unlike his fellow-theorist, Charles Darwin, he has not devoted his life to the elucidation of a single problem, or attempted the exhaustive treatment of any topic, but has given his attention to subject after subject without an effort to probe any one to the bottom. While unusually quick in the appreciation of causes and principles, as evidenced in his theory of natural selection and many minor theoretical views, it is rather quickness than depth, his conceptions being reached at a leap, as it were, and never pursued to their ultimate with the hard and persistent labor of the great masters of thought. His scientific friends say that he is almost intuitive in his readiness in solving a problem in natural history, but his quickness does not seem combined with persistence, and, with all his fine powers of thought, he has failed to win the leading position in science which some of less native brilliancy of thought have attained. As a writer he is comprehensible and pleasing, his works being clearly and attractively written, and full of that enthusiasm in his subject which is needed to arouse the interest of the reader to its fullest extent. They have been widely read and have aided much in the popularization of science. (C. M.)

WALLACE, LEWIS, general and author, was born in Fountain co., Ind., in 1827, son of David Wallace (1799-1859), formerly governor of that State. He studied law and was admitted to the bar, but during the Mexican war threw up his practice and joined the army as second lieutenant of First Indiana Volunteers. After the war he returned to the practice of his profession in his native State, of whose senate he was member for a year. At the outbreak of the rebellion he was adjutant-general of Indiana, but in April, 1861, he was chosen to the command of the Eleventh Indiana Volunteers (three-months' men), and served with it in West Virginia, at the capture of Romney, and elsewhere. This regiment's term expired in August, 1861, but, mainly through his zeal and influence, it was forthwith reorganized under his command. In September he received his commission as brigadier-general of volunteers, and was for a time stationed in Kentucky. He commanded a division at the capture of Fort Donelson, occupying the centre of the National lines, and manifested such gallantry and skill that he was promoted major-general of volunteers, March 21, 1862. In the battle of Shiloh his division occupied Crump's Landing, on the Tennessee, some 8 miles lower down

than the field of battle, and was not engaged the first day. On the second day it rendered efficient service, as it did also in the subsequent advance on Corinth. In the court of inquiry, which sat in November to inquire into the conduct of Gen. Buell, Gen. Wallace was president. In 1863 he prevented the capture of Cincinnati by Gen. Kirby Smith, and was next year assigned to the command of the Middle Department and Eighth Army Corps, with which he met Early marching on Washington, but was defeated by him on the banks of the Monocacy, Maryland, July 9, 1864. On this Gen. Ord was directed by Halleck to supersede Wallace, but Grant promptly reinstated him. He had, in fact, succeeded in his main object, which was to give Grant time to reinforce Washington from City Point. He was a member of the commission which sat in 1865 for the trial of the persons implicated in the assassination of Pres. Lincoln and the attempt on the life of Sec. Seward, and was president of the court that tried Capt. Wirz, of Andersonville prison. After the war Gen. Wallace engaged in the practice of law at Crawfordsville, Ind. Here also he wrote his first work of fiction, *The Fair God* (1873), a story of Mexico. In 1881 he was sent as U. S. minister to Constantinople, and in next year was made envoy extraordinary and minister plenipotentiary at the same court. He returned to the United States in 1885.

Gen. Wallace has shown uncommon faculty of turning to new subjects of diverse kinds, and mastering them with the zeal and enjoyment of youth. He was distinguished as a soldier, a general, and a lawyer; he handles the brush with the facility of an artist. Few literary productions have so suddenly leapt into fame as his *Ben Hur* (1880, New York). The circulation of the latter work has been quite phenomenal, and an eminent critic has said, "*Ben Hur* is altogether the most noteworthy novel ever written by an American." In 1888 these were succeeded by another work, *The Boyhood of Christ*, in which he has made use of the stories in the Apocryphal Gospels. For the Presidential campaign of 1888 he wrote a biography of his friend, Gen. Benjamin Harrison. In *Harper's Magazine* for January, 1889, he published a tragedy in blank verse, entitled *Commodus*. Gen. Wallace resides in Crawfordsville, Ind., mainly occupied with literary work. His wife, Mrs. Susan E. Wallace, is a brilliant and picturesque writer of historical and descriptive sketches.

WALLACE, WILLIAM HARVEY LAMB (1821-1862), general, was born at Urbana, Ohio, July 8, 1821. In 1833 he removed with his father to Illinois, where he studied law in Springfield and Ottawa. On the occurrence of the Mexican war, he enlisted in Col. Hardin's regiment, the First Illinois Volunteers, rising to be lieutenant and adjutant and was engaged in the battle of Buena Vista. In 1853 he was elected State attorney for the 9th circuit of Illinois, and in May, 1861, he was commissioned colonel of the Eleventh Illinois regiment. At the capture of Fort Donelson in February, 1862, he commanded a brigade in McClelland's division and bore so conspicuous a part that on March 21 he was promoted brigadier-general. At the battle of Shiloh he commanded the division of Gen. C. F. Smith, absent on account of sickness. When the three other divisions were routed, Wallace, in conjunction with Gen. Hurlbut, for six hours held the field against the force of the enemy flushed with victory. At the end of the struggle Gen. Wallace fell mortally wounded, "closing in death," says Horace Greeley, "a day's work which had won for him the admiration of all beholders and the gratitude of his country." He died at Savannah, Tenn., April 8, 1862.

WALSH, ROBERT (1784-1859), author and journalist, was born in Baltimore in 1784, and was educated at the Catholic College there and Georgetown College, D. C. After completing his course he went to Europe, where he remained until his twenty-fifth

year. On his return he studied law but soon abandoned it for literature, beginning his career on *Demie's Portfolio*. His *Letter on the Genius and Disposition of the French Government* (1809) was received with favor and went through four editions in England. In 1811 he instituted the *American Review*, the first quarterly in America, carrying it on for two years. He next published his *Correspondence with R. G. Harper respecting Russia*, which was followed by an *Essay on the Future State of Europe*. From 1817 to 1819 he edited the *American Republic*, and in the latter year appeared his *Appeal from the Judgments of Great Britain respecting the United States*. In 1821 he founded, in conjunction with Mr. Frye, the *National Gazette*, which shortly became a daily, and was enriched for 15 years with his genial articles on books, art and science. He was at the same time associate editor of the *American Magazine of Foreign Literature* (the precursor of the *Museum* and *Littell's Living Age*), but resigned his connection with it to resuscitate the *American Review*, which he conducted from 1827 till 1837. His contributions to the *Gazette* were issued separately under the title of *Dialectics* (1837). In 1845 he was appointed U. S. consul at Paris, where he remained till his death on Feb. 7, 1859. While abroad he was a frequent correspondent to American periodicals, and contributed to *Lieber's Encyclopædia Americana* the articles on American biography.

His son, ROBERT MOYLAN WALSH (1811–1872), diplomat and litterateur, was born in Philadelphia, April 27, 1811, and was educated at William and Mary College. At the age of 19 he went to London as attaché to the American legation there, of which Washington Irving was secretary. He subsequently held various diplomatic appointments in different countries, and was for a long time a resident of Italy, where he held the positions of secretary of legation at Naples and U. S. consul at Leghorn. He returned to the United States in 1867, residing for a time in Philadelphia, and finally in Camden, N. J., where he died March 1, 1872. He inherited literary tastes from his father; contributed to the *Encyclopædia Americana*; translated some French books; and, in the intervals of his diplomatic engagements, assisted in editing the *National Gazette*. During his later years he contributed to *Lippincott's* and *Scribner's Magazines* and other periodicals.

His son, WILLIAM SHEPARD WALSH, litterateur, was born at Paris, Feb. 1, 1851. His boyhood was spent in Italy, but in 1867 he returned with his parents to the United States. He spent two years in Georgetown College, D. C., and thereafter studied law in Philadelphia, graduating in 1876 in the law department of the University of Pennsylvania. But his tastes, inherited from his father and grandfather, were essentially literary, and instead of entering on his profession he accepted the position of literary reader in the establishment of J. B. Lippincott Co., and in 1885 became editor of *Lippincott's Magazine*. Mr. Walsh, under the name of "William Shepard," has published several books, including *The Literary Life Series*, *Young Folk's History of the Roman Empire*, *Young Folk's Josephus*, and, under his own name, *Faust the Legend and Poem* (Phila., 1887), and *Paradoxes of a Philistine* (Phila., 1888). As a literary critic Mr. Walsh has few equals. His knowledge of books is exceptionally wide, his tastes catholic, and his judgment, matured by large experience, sound and unbiased.

WALTHER, CARL FERDINAND WILHELM, Lutheran theologian, was born at Langenschursdorf, Saxony, Oct. 25, 1811. He graduated at the University of Leipzig in 1833, and emigrated to the United States in 1838. He became in 1849 pastor of a Lutheran church in St. Louis and president of Concordia Seminary. By his ability and learning he took a prominent position among the Lutherans of the Western States. He endeavored to restore the confessional orthodoxy, and provoked a serious controversy as regards predestina-

tion. The Missouri Synod, under his direction, became a separate body, and it has been largely increased by immigration. Among his publications are *Die Evangelische Lutherische Kirche* (1867); *Amerikanisch-Lutherische Evangelien-Postille* (1871); *A.-L. Pastoral Theologie* (1872); *Der Concordienformel Kern und Stern* (1877); *A.-L. Epistel-Postille* (1882).

WALTON, GEORGE (1740-1804), a signer of the Declaration of Independence, was born in Frederick co., Va., about 1740. He was first apprenticed to the carpenter's trade, and during his term acquired a fair education by private study. Subsequently he studied law in Georgia and was admitted to the bar, settling in Savannah for the practice of his profession in 1774. Walton, a patriot from the first, was one of four persons who called the first public meeting at Savannah for the purpose of concerting measures for resisting the aggressions of the crown and the defence of Georgia, and the resolutions adopted on that occasion were drawn up and largely suggested by him. In February, 1776, he was appointed a delegate to the Continental Congress, and as such signed the Declaration of Independence. He was re-elected in 1777 and signed also the Articles of Confederation. Being commissioned colonel of militia in December, 1778, he took part in the defence of Savannah, where he was dangerously wounded, and remained a prisoner till September, 1779. Next month he was chosen governor of Georgia, and again attained that dignity in 1789. He was four times a judge of the Superior Court of Georgia; was appointed delegate to the Philadelphia Constitutional Convention of 1787, but declined the office. In 1795 he was chosen U. S. Senator for one year. He died at Augusta, Ga., Feb. 2, 1804.

WALWORTH, REUBEN HYDE (1789–1857), jurist, was born at Bozrah, Conn., Oct. 26, 1789, and taken at the age of four to Hoosick, N. Y. At 16 he began to teach, and obtained 3 months' tuition in Latin and mathematics. Disabled a year later by an accident, he became a clerk in a country store and studied law. He was admitted to the bar in 1809, and entered on a successful practice at Plattsburgh. In the war of 1812 he was a major of militia and acting adjutant-general, serving as judge-advocate in two military trials, and taking part in the local operations of 1814. After the war Gov. Clinton commissioned him division judge-advocate, with the rank of colonel. He removed to Saratoga, was sent to Congress 1821, made circuit judge 1823, and chancellor of New York 1828. This position he held with great credit for 20 years. Many of his decisions are included in *Paige's & Barbour's Reports*, 1830–49, and those delivered in the Court of Errors, wherein he sat *ex-officio*, in the *Reports of Wendell, Hill & Denio*, 1829–50. His adjudications in MS. fill 39 folio volumes. His predecessor, Chancellor Kent, testified to his merit, and Story called him the greatest equity jurist living. In 1844 he was strongly recommended for the U. S. Supreme Court, and Pres. Tyler sent his name to the Senate, but it was withheld in the judiciary committee till that of Judge Nelson was substituted. The Court of Chancery was abolished by the Constitution of 1846, but Walworth's office and salary were continued a year longer. After withdrawing from the bench he confined himself to chamber practice, declining in 1847, and again in 1849, the headship of a committee to codify the laws of New York. He was a Presbyterian elder, first president of the State Temperance Society, 1829–43, and then president of the American Temperance Union, vice-president of the Bible and Tract Societies, and a member of the American Board of Commissioners for Foreign Missions. In 1832 he, with Dr. Nott and B. F. Butler, of New York, settled a dispute between Georgia and the U. S. Supreme Court. Walworth published *Rules and Orders of the Court of Chancery* (1829), and prepared the *Hyde Genealogy* (2 vols., 1864), said to be the most elaborate work of its kind at that time. He died at Saratoga, Nov. 21, 1857.

WAR OF 1812. This second war between Great Britain and the United States was declared, pursuant to Act of Congress, June 19, 1812, and continued 2 years and 9 months, being nominally terminated by the treaty of Ghent, Dec. 24, 1813, but actually ended, owing to delay in transmitting news, March 23, 1815.

Causes.—1. The seizure of U. S. seamen on board of U. S. vessels; ostensibly a right to apprehend deserters; but, in enforcement, so many sailors were forcibly taken as to cripple U. S. commerce, treating it like that of an enemy. (See SEARCH, RIGHT OF.)

2. Continued efforts of the U. S. government to obtain redress and guarantees against the repeated acts of aggression were fruitless.

3. When at war with other powers Great Britain claimed a right to make an extensive blockade beyond the actual local enforcements. This led to the capture of U. S. neutral vessels and goods and to the practical destruction of American commerce.

4. In time of peace a British 50-gun ship attacked the U. S. frigate Chesapeake, and the British sloop-of-war Little Belt fired into the U. S. frigate President.

5. The main and repeated acts of violence were the impressing of seamen. Six thousand cases of alleged impressment of U. S. citizens into the British service were recorded at Washington. When the war began 2500 such citizens had been committed to British prisons.

First Conflict.—When it was proclaimed there was in America little or no preparation for war. The frontier military posts were not even apprised. Some British merchants of New York promptly sent an express to Sir Isaac Brock, then commanding the Canadian troops, and he immediately sent orders to Capt. Roberts, his post-commander at St. Joseph's, to move at once against the nearest U. S. garrison which was kept on the island named Michilimacinae (now Mackinac). Capt. Roberts, adding volunteers and Indians to his regulars, amounting to 900, with two field-guns, embarked in boats the very day he received the orders. At 3 A. M., July 17, 1812, he landed at Michilimacinae and without delay took possession of a neighboring hill which dominated the fort, and there planted his artillery. Lieut. Porter Hancks, with a battery of 57 men, including officers and a few cannon, was holding the fort. At 11.30 A. M. Roberts sent in his demand for an unconditional surrender, with a threat of extermination if resisted. This proceeding was Lieut. Hancks' first intimation of a declaration of war. Hence surprised, outnumbered, and his works already dominated, the lieutenant surrendered without firing a shot. Thus the war commenced.

Campaigns of 1812.

The North-west.—Gen. Wm. Hull, a veteran of the Revolution, with 3000 raw troops, had marched into Michigan, crossed the Detroit River, and occupied Sandwich. Gen. Brock sent a force to Malden, which disturbed Hull's line of supply. Hull, on Aug. 4, detached Major Van Horn with 200 men to go to Raisin River in order to strengthen Capt. Brush's company of Ohio volunteers and help bring up provisions. A British Capt. Tallon with a few regulars, and Indians led by the famous Tecumseh, ambushed Van Horn *en route* near Brownstown. Van Horn was defeated, and retreated with a loss of 7 officers and 19 men, and the mail for Hull's army passed into the hands of the British.

In view of this defeat, Hull, on Aug. 8, recrossed the river and occupied Detroit, and then again undertook to reopen his communications southward, sending out Lieut.-Col. Miller with 600 men. This force encountered at the Magnaga some 400 British, including Canadians and Indians, led by Capt. Muir and Tecumseh, and gained a victory, yet Gen. Hull for some reason recalled the troops and so the fruits of Miller's victory

were lost. Gen. Hull's army had an out-post, near the site of Chicago, Fort Dearborn, commanded by Capt. Heald and garrisoned by about 50 soldiers; besides, there were present several civilians. Hull ordered the captain to evacuate the fort and join him, and Heald, relying for support upon some Indians, apparently friendly, commenced the march. He soon met an Indian ambuscade, and, after a severe battle, was compelled to surrender with an aggregate loss of 66 soldiers and citizens. The captain and his wife, both wounded, were set at liberty, made their way to a near British garrison and gave themselves up. This Fort Dearborn affair has been named "the massacre of Chicago."

The able British Gen. Brock, with regulars, volunteers, and Indians, not much exceeding Hull's army in numbers, followed up Hull's retreat and hemmed him in at Detroit. Hull refused the first summons to surrender, made Aug. 15; but when the hostile forces had drawn in closer to the fort and the artillery was preparing to open fire, the beleaguered general sent out a flag of truce and surrendered not only his army present, and the fort, but absent detachments and substantially the whole territory of Michigan. Fourteen hundred men, much cannon and provisions, were given up, and thus ingloriously the first campaign was closed.

The British general sent Maj. Muir with a detachment of regulars to assist the Indians that were massed under Tecumseh, in attacking Fort Wayne. The assault was planned for Sept. 1, 1812. Gen. W. H. Harrison, then in Ohio, hearing of the hostile movement pushed forward with a strong force to strengthen the garrison. But the major and the Indians, quickly apprised of his march, retired northward without a blow. Harrison reached the place Sept. 12. On the 3d the threats against Fort Wayne had already passed to the next frontier post, Fort Harrison, on the Wabash, and two young men in its neighborhood were killed and scalped. The next evening a suspicious company of Indians begged for admission. Capt. Zachary Taylor (afterwards General and President) was in command. That night Indians swarmed about the garrison; and a blockhouse close to the fort was set on fire. Taylor had less than 50 men, most of whom were sick in hospital, yet inspired by their captain all went to work to check the fire which spread to other buildings, to raise a temporary breastwork, and for eight hours to resist repeated assaults. For more than two days the little garrison held its own against overwhelming numbers. The Indians angered by this unexpected resistance brought cattle, horses, and hogs from the neighboring farms and slew them within sight of the garrison. At last, Sept. 5, 1812, the savages abandoned their fruitless efforts and left. Capt. Taylor and his soldiers received abundant thanks for their gallant defence.

The Indians, who were greatly excited and stimulated by the promises of the wily Tecumseh, made another attack on Fort Madison, which was situated not far from St. Louis, Mo. Some 200 Winnebagoes crept up to the fort, on the evening of Sept. 5, and slew a number of the garrison, found outside the fort. Lieut. Hamilton, thus warned, having a detachment of regular infantry, defended his fort against every expedient of the enemy, who used flaming arrows, burning fagots, and other means of firing the wooden roofs. Hamilton invented on the spot effective fire-extinguishers, made from gun-barrels. The conflict was kept up till 10 P. M., Sept. 7, when the Indians, despairing of success, raised the siege and fled.

The Central Department.—Turning now from the North-west department to the Central, the next battle of importance was that of Queenstown, Oct. 13, 1812. Gen. Van Rensselaer, with about 1200 troops, crossed the Niagara River and engaged a British force of about the same numbers made up of regulars, volunteers, and Indians. His command were nearly all killed or captured. Capt. (afterwards General) J. E. Wool and

Lieut.-Col. Winfield Scott (for whom see ENCYCLOPEDIA BRITANNICA) greatly distinguished themselves during this conflict. The British commander, Gen. Brock, was here slain. It was a remarkable incident that a large force on the American shore beheld their comrades in peril but refused absolutely to render them any assistance. This wretched conduct doubtless arose from an absurd opposition to fighting beyond the boundaries of New York. The Queenstown battle was well planned, but the means were inadequate to its execution. Before this battle, on Oct. 4, a skirmish occurred which gave a little relief from the mistakes and disasters of this department. A British force, perhaps 800 strong, under Col. Lethbridge, in boats approached Ogdensburg, which was defended by Gen. Jacob Brown, of the New York militia. He had about 1000 men. The British were stoutly met, defeated, and forced to withdraw to the Canadian shore. But not long after this success a similar British detachment here defeated 300 militia, and took possession of the town and fort. The attacking party lost about 60 men killed and wounded—the militia much less.

Campaigns of 1813.

Battle of Frenchtown.—Meanwhile in the North Gen. Harrison had been pushing his operations, aiming to recover Michigan. A portion of his army, which had not yet joined the main body, was leading the way northward under Gen. Winchester's command. Not far from Maumee Rapids the general received a despatch from Harrison warning him that the Indians were gathering in his front. Other messages of like nature reached him; but on Jan. 16, 1813, messengers from the Raisin River country came in haste and begged for help in behalf of the threatened settlements. Winchester, leaning to humanity, detached Col. Lewis with 550 men, and a few hours later Col. Allen with 110 more. These two parties united at Presque Isle (now Erie, Pa.). Near the Raisin River 100 British and 400 Indians with one cannon were in waiting. During Jan. 18 Lewis attacked the main position of his enemy strongly posted in Frenchtown, and succeeded in defeating both the regulars and Indians and then slowly drove them back till darkness ended the battle.

Raisin River Massacre.—During Jan. 19, as soon as Gen. Winchester heard of Lewis' success he brought up to Frenchtown all his force, except a small guard. A French settler reported to him that a hostile movement from Malden was on foot; yet the weather being exceedingly cold proper precautions against attack were neglected. About sunrise on the 22d Proctor with some 500 whites and 600 Indians sprang upon the general's lines. Notwithstanding the surprise the patriot soldiers for a time fought desperately, but the angry missiles seemed to come from every direction, so that the men became discouraged and gave way. Then followed the massacre of many prisoners and the compulsion of Gen. Winchester after his own capture to surrender a gallant remnant. The wounded were seldom spared and the little town was burned by the savages. This affair equals the Wyoming murders. Proctor was promoted for his success, yet fair-minded Americans and English condemned him for violating every rule of honor. Out of 1000 men Winchester lost 397 killed and missing, and 537 as prisoners of war. Proctor's loss, surprisingly small, was but 24 killed and 158 wounded. The terrible news produced, especially in Kentucky, profound grief and soon the most vigorous action; so that Gen. Harrison was speedily reinforced.

Siege of Fort Meigs.—At the Rapids of the Maumee Harrison established Fort Meigs. This was strategically excellent; it protected the country below, and was a starting-point to recover Michigan. Proctor, seeing this, soon started from Malden purposing to capture this fort. He took by water over 2000 mixed troops, Tecumseh leading the Indians. A couple of gunboats and some artillery aided his attempt. He

opened fire May 1, 1813, carefully drawing his cordon around the fort; whilst Harrison strengthened his work by every available contrivance. Happily, on May 4, he was largely reinforced. The incoming dislodged the besiegers, but met with great losses at the hands of Tecumseh owing to their too eager pursuit of fleeing Indians. Yet Proctor was speedily compelled to abandon the siege and withdraw. Harrison's important victory here was dearly purchased, over 800 being put *hors de combat*, while Proctor claimed that his loss did not exceed 100.

Naval Battle on Lake Erie.—The British naval commander, Barclay, had already managed to get, on Lake Erie near Malden, 6 war vessels into working order. At the same time for the United States Lieut. Elliott and later Commodore Perry were gathering and constructing quite a squadron (8 or 9 vessels) in the harbor of Presque Isle. Early on Sept. 10 Perry's squadron was anchored in Put-in Bay. Barclay made his appearance and a battle ensued. Perry, after long fighting and heavy loss, gained a decisive victory which filled the country with joy and hope.

Battle of the Thames.—Lake Erie being thus regained, Gen. Harrison hastened to bring up abreast the land operations. With the help of the navy he transferred his troops northward to a small island named the Eastern Sister, about 12 miles from Malden, Proctor's stronghold. Getting fairly ready, on Sept. 27 he pushed for Malden. Proctor, having destroyed his stores, had already fled to Sandwich, having with him Tecumseh and an army of perhaps 1800 whites and Indians. Gen. Harrison, leaving a guard at Amherst, sped on after him with his 3500 men. Col. Lewis Cass and Commodore Perry were Harrison's volunteer aides. Proctor again escaped at Sandwich, but after a swift pursuit was at last brought to bay near the Moravian Town (Orford, Canada West). He took up a strong position by the River Thames and accepted battle Oct. 5, 1813; he was badly defeated, and Tecumseh, who held out the longest, was slain. For this Proctor was court-martialled and disgraced, for alleged want of generalship. This battle of the Thames, added to Perry's victory, gave back to the United States the entire North-West.

The North-East.—Farther east a singular campaign was inaugurated. The Northern army, commanded by Gen. Wilkinson, was much scattered, the right under Gen. Hammond, at Plattsburg, the left under Gen. Boyd, near Niagara River, while Wilkinson retained the centre at Sackett's Harbor. Fifteen thousand men comprised the whole. The British opposing forces, extending from Niagara Falls through Kingston to Montreal, numbered about 8000. There was a remarkable parade about the proposed Canadian expedition. The war department itself left the capital and went to Sackett's Harbor. Gen. Armstrong, secretary of war, had been a high officer in the Revolution, and must take an active part. Combined movements were concocted, but, as one might anticipate, there was a confusion of counsels and cross-purposes.

At last in Canada an American brigade-commander, Gen. Izard, preceding one of the columns with his brigade, came upon a British force under Lieut.-Col. De Salberg in position near the Chateauguay and Outarde confluence. There were breastworks manned by at least 1000 men, some of whom were Indians. Gen. Izard drove in the pickets of De Salberg and then engaged the main body. He was progressing finely, when scattered firing and blowing of bugles (sent out by De Salberg) were heard from the woods near at hand. This ruse had such an effect upon Wade Hampton, the column commander, that he ordered an instant retreat. A second showy attempt against Montreal under the immediate charge of Gen. Wilkinson proved equally futile. The entire campaign was a sorry failure.

During the early part of 1813 Fort George, and York, Canada, were taken by the Americans. Gens.

Chandler and Winder led from Fort George some 1500 men to farther invade Canada. These were defeated and largely captured, the remnant fleeing back to Fort George for refuge. Some 600 Americans under Col. Boerstler were captured by the smaller force and suffered disgrace. The successful attack by a British detachment on Black Rock had its reprisal in a subsequent defeat at the hands of the American militia.

An instance of wanton destruction by Gen. McClure (U. S. army), who burned Newark, Canada, and then escaped to New York State in terror, marred the American record. The capture of Fort Niagara with its 400 by a night surprise from 600 British soon followed McClure's folly. Another British attempt on Black Rock succeeded; 1500 American militia were put to flight and Buffalo taken. So this Northern frontier work ended the year 1813, a prey to many fruitless conflicts.

Campaigns of 1814.

This irregular, ill-planned campaign was opened by Capt. Holmes, with 160 men, defeating 300 British at Longwood, Canada. A little after this, crossing Lake Ontario, the British seized Oswego, but lost heavily in an encounter that soon followed. Meanwhile the U. S. Gens. Brown and Scott busied themselves in the drills and discipline of new troops. Early in July they captured Fort Erie, and on the 4th Gen. Brown, with whites and Indians 3000 strong, had a brisk engagement, defeating Gen. Rial, commanding 2500 British, at Chippewa. Here Gen. Winfield Scott won a victory in a bayonet charge against English regulars.

Again the battle of Lundy's Lane (July 25, 1814) brought 3000 Americans against 3500 British. Scott made a harder fight than before, and was badly wounded. His successor drew off his men in the ensuing night. So the British Gen. Drummond, though dislodged and put to flight, soon returned and always claimed the victory. Drummond, unduly encouraged, then undertook the recapture of Fort Erie, Gen. Gaines commanding, but failed. Another small affair

occurred at Black Rock, where Col. Tucker attacked Major Morgan's 300 Americans. Morgan repelled the assailants with loss. On Sept. 17, after Gen. Brown's return to Fort Erie, he made a sally against the besiegers, now 4000 strong. Each army claimed the victory in this conflict, but the British gave up the field. Yet the American troops, on Nov. 5, were withdrawn from Canada.

An invasion of the United States farther east, from Lake Champlain to Plattsburg, N. Y., by Sir George Prevost with over 12,000 men, proved abortive. As soon as Com. McDonough had defeated the British fleet on the lake, Sir George, with the land troops, fled in much haste. Small portions of Maine were conquered by the British and held till peace. So much for operations in the North-east.

The Capture of Washington, D. C.—In the South during August the British, about 5000 in number, under Gen. Ross, came boldly up the Chesapeake and the Patuxent, and landing, marched via Bladensburg on Washington itself. Near Bladensburg Gen. Winder had gathered a small opposing force, and after a skirmish was soon dislodged by a British bayonet charge, having lost 26 killed and 50 wounded. Washington was taken and the public buildings burned. Gen. Ross at once drew back, but made a similar expedition in September, against Baltimore. There was a sharp battle at North Point which seemed favorable to the British; but Ross was killed and his losses were 288 killed and wounded. The American Gen. Stryker had 113 killed, wounded, and missing. At Washington and Baltimore, on the part of the U. S. government, there had been a shameful want of preparation. But the British fortunately were content with the damage inflicted, and did not follow up their boldness with any permanent advantage.

Naval Battles of the War—Besides those already described the naval actions were mainly duels between American and British vessels. The table shows the principal. (The star indicates the victorious vessel.)

Naval Battles of 1812-15.

Date.	U. S. Vessel.	Commander.	British Vessel.	Commander.
Aug. 13, 1812.....	Essex *	Cap. Porter.....	Alert.....	Cap. Langhorne.
Aug. 19, 1812.....	Constitution *	Cap. Isaac Hull.....	Guerriere.....	Cap. Dacres.
Oct. 8, 1812.....	Wasp *	Cap. Jones.....	Frolic.....	Cap. Whinyates.
Oct. 25, 1812.....	United States *	Cap. Decatur.....	Macedonian.....	Cap. Curden.
Dec. 29, 1812.....	Constitution *	Cap. Bainbridge.....	Java.....	Cap. Lambert.
Feb. 24, 1813.....	Hornet *	Cap. Lawrence.....	Peacock.....	Cap. Wm. Peake.
June 1, 1813.....	Chesapeake.....	Cap. Lawrence.....	Shannon *	Cap. P. B. Vere Broke.
Aug. 5, 1813.....	Decatur *	Cap. Diron.....	Dominica.....	Cap. Barrette.
Aug. 15, 1813.....	Argus.....	Lt. Wm. H. Allen.....	Pelican *	Comdr. Maples.
Sept. 5, 1813.....	Enterprise *	Lt. Burrows.....	Boxer.....	Comdr. Sam. Blythe.
June 28, 1814.....	Wasp *	Cap. Blakely.....	Raindeer.....	Cap. Manners.
March 23, 1815.....	Hornet *	Cap. Riddle.....	Penguin.....	Cap. Dickinson.
June 23, 1815.....	President *	Com. Rodgers.....	Belvidere.....	Cap. Byron.

Jackson's Campaigns.—As a result of Tecumseh's influence among the Indians of the South-west, a large body went on the war-path and made a stand for battle at Tallushatchee settlement, situated on a branch of the Alabama River. Against them Gen. Andrew Jackson gathered a force of about 2500 men. He ordered his lieutenant, Gen. Coffee, to destroy the settlement. The latter, with 900 men, crossed the river, and having approached within 1½ mile of the village, organized his force into two columns and endeavored to encompass the enemy. Not succeeding in a surprise the expedient was tried of a small detachment retreating before the savages until the eager pursuers were brought under the fire of the main body: the Indians retreated to their families and are said to have "fought so long as they could stand or sit." One hundred and eighty-six Indians were killed in this engagement and 84 women and children taken

prisoners, while there were only 46 casualties in Coffee's command. This battle was fought Nov. 3, 1813. On Nov. 9, 1813, occurred the second battle, Talladega, under Gen. Jackson's direction. The loss of the Indians in this action was 299 killed, while the Americans' was but 15 killed and 80 wounded. On Nov. 18, while Gen. Jackson was negotiating with the Illinois Indians, by some misunderstanding, detachments under Gens. Cocke and White attacked the Indians' village near the Tallapoosa River. The Indians, having plighted their faith to Jackson, were attacked and slaughtered without making resistance; 60 were killed and 256 captured, the assailants not losing a man. On Nov. 29 occurred the battle of Antossee. A small force of irregular troops under the immediate leadership of Gen. Floyd, of Georgia, massacred some 200 Indians. There was but faint resistance, Floyd's men suffering but little loss, viz., 11 killed, 54 wounded.

On Dec. 23 the next battle, Ecanahaca, was fought by Gen. Claiborne, who had a mixed force of whites and friendly Indians. The hostiles suffered a complete route, losing about 30 killed and their two villages of more than 200 houses burned. Claiborne's loss in the engagement was 1 killed and 6 wounded. In the next battle, that of Emuckfau, Jan. 22, 1814, it is difficult to tell the numbers engaged. Gen. Jackson was present in person and fell back to Fort Strother the day after the engagement. The Indians regarded this action as a victory for them and greatly disturbed his retreat. A heavy skirmish at Enotochopeo was a part of this retreat, resulting in a great loss to the pursuers. Gen. Jackson was much incensed at his losses and at the appearance of defeat. He soon reorganized his force and set on foot another expedition of about 3000 whites, with a body of friendly Indian allies. On March 27, 1814, he fought the battles of Tohopaka or Horse-Shoe Bend, on the Tallapoosa.

Jackson's loss in the attack was 202 killed and wounded; the hostile Creeks lost 557 killed on the field and about 300 more killed while trying to cross the Tallapoosa; but few, if any, of those engaged in battle escaped death. It is said that there were about 300 women and children taken prisoners. Such is a specimen of Gen. Jackson's severe Indian warfare. This last terrible engagement broke the power of the Indians in the South and South-west.

The next time we meet Gen. Jackson is Dec. 2, 1814, at New Orleans. He gathered there such an army as he could, and made ready against a British force already reported approaching from the Gulf of Mexico. The latter was commanded by Sir Edward Pakenham, and numbered of all arms about 9500 men, including over 1000 seamen. Jackson's whole command did not exceed 3700 effectives, most of whom were raw levies. The entire conflict was embraced between Dec. 10, 1814, and Jan. 18, 1815. What is usually called the Battle of New Orleans took place on Jan. 8, being a British assault on Jackson's prepared lines, in which the assailants sacrificed nearly 3000 men and lost also their commander, Sir Edward Pakenham, and two other generals. Jackson's loss was very small, as he was fighting from behind breastworks. The treaty of peace between the United States and Great Britain had been agreed upon at Ghent, Belgium, nearly a month before this battle, but the fact was not known till long afterwards. (C. O. H.)

WARBLER. This name is given, with the necessary modifying terms, to a very great number of highly characteristic North American birds. In a wide sense all the great family of *Sylvioidae* may be called Warblers; but the name belongs specially to the sub-family *Sylviolinae*, which includes 10 recognized North American genera, namely: *Mniotilta*, the creeping warblers; *Parula*, with four or more beautiful species; *Protonotaria*, the swamp or prothonotary warblers; *Helminthorus* and *Helminthophila*, the latter with 8 or more good species; *Pencilvannus*, the olive warbler; the great genus *Dendroica*, the wood warblers of some 35 species, mostly North American and West Indian; *Sayornis*, the wag-tail warblers; *Oporornis*, the bush warblers, and *Geothlypis*, the ground warblers. To the sub-family *Setophaginae* belong a few North American and many South American forms. Many of the warblers are exceedingly beautiful little birds, and they are all of them, as active insect-feeders, valuable friends to the farmer. Notwithstanding their name, only a few are specially gifted in song. They are closely allied to the Tanagers, and have certain affinities with the honey-creepers. Some of them simulate the *Tyrannidae*, especially in their habits; others seem to approach the nuthatches, the titlarks, the wrens, the titmice. Most later systematists group the *Icteriinae* or chats with the warblers; but upon doubtfully sufficient grounds. (C. W. G.)

WARD, ARTEMAS (1727-1800), general in the Revolutionary war, was born at Shrewsbury, Mass., Nov. 27, 1727. He graduated at Harvard College in 1748, and in 1755 became major in the regiment of Col. E. Williams, rising in Abercrombie's campaign against the French near Lake Champlain to the rank of a colonel. In 1774 he was elected a delegate to the provincial council of Massachusetts, and his military experience and high reputation secured his appointment as a general officer in October of that year. In the following May, when the Revolutionary war had begun, he was commander-in-chief of the Massachusetts forces. During the battle of Bunker's Hill he remained at his head-quarters at Cambridge. In June, 1775, the Continental Congress placed him first on the list of major-generals, and, as such, he was commander-in-chief at the siege of Boston until the arrival of Washington, when he became his second, with head-quarters at Roxbury, and had command of the right wing. He resigned in consequence of ill health in April, 1776—a month after the capture of Boston. In this year he was chief-justice of common for Worcester co., and in 1777 president of the Massachusetts executive council. For 16 years he was a member of the State Legislature of Massachusetts and its speaker in 1785, and from 1791 to 1795 he was member of Congress. He died at Shrewsbury, Oct. 28, 1800.

WARD, FREDERICK TOWNSEND (1831-1862), a soldier of fortune who won distinction in China, was born at Salem, Mass., and received his education in the public schools. He early developed a roving, adventurous, and military disposition and after serving with the French army in the Crimea, (where by some means he obtained a commission) was connected with the filibustering schemes of William Walker, and then wandered to Mexico. Making his way to China, he obtained the confidence of the government and the title of "admiral general," and rendered very eminent services in putting down the Tae-ping rebellion. His first exploit was the taking of Sunkiang after one unavailing attack. He was singularly useful in drilling and organizing the native troops; out of this poor material, despised by foreigners, he managed to evolve "the ever-victorious army," which was able to hold its own in the field against ten times its number of Tae-ping rebels, whom they defeated in several engagements and drove from the Yung River valley. Ward was brave, honorable, energetic, and possessed of great executive and soldierly ability; his career is comparable to that by which "Chinese" Gordon won his earliest fame. He deserved and gained the confidence and respect of the mandarins, who reported in his favor at Peking. His brilliant successes were cut short at the early age of 31, in an action at Tyki near Ningpo, Oct. 7, 1862. At Sunkiang, where his remains were interred, a shrine was erected to him, and semi-divine honors were paid there by the grateful Chinese for some years, if not to the present day. (See S. Welles Williams' *Middle Kingdom*, 1883.)

WARD, MARY AUGUSTA, English novelist, was born at Hobart, Tasmania, June 11, 1851. She is the eldest daughter of Thomas Arnold, fellow of the Royal University of Ireland, and granddaughter of the famous Dr. Thomas Arnold of Rugby. She was married in 1872 to Thomas Humphry Ward, fellow of Brasenose College, Oxford, who has since edited a collection of *The English Poets* (4 vols.), and the twelfth edition of *Men of the Time* (1884). Mrs. Ward resides in Oxford. Her first publications were a story for children, *Milly and Olly* (1880), and *Miss Bretherton* (1884), in which one of the characters is said to be modelled from the actress, Miss Mary Anderson. Much of her literary work had regard to foreign languages, in which she is well versed, witness her translation of *Amiel's Journal* (1885), to which she prefixed an introduction, and her papers on Continental literature in the *Quarterly Review* and other periodicals. She also wrote, for Smith and Wace's

Dictionary of Christian Biography, lives of the early Spanish saints, kings, etc. But all her former work, however preparatory in its nature, was eclipsed by her powerful delineation of modern spiritual unrest in *Robert Elsmere* (1888). The work needed not the elaborate criticism and answer by Mr. Gladstone in the *Contemporary Review* (June, 1888) to obtain almost instantaneously a wide reading. The plot of the story is slight, but the dramatic power is unusually great, and some of the characters are remarkably lifelike, while against others the criticism is made that they are rather impersonations of certain tendencies of thought than actual persons. The popularity of the work, however, is not due merely to its literary and artistic excellence, but also to its bold attempt to tear aside the veil which covers much contemporary skepticism. Its admirers pronounce it a revelation of facts and opinions which need to be declared, while others who deny its truth as a complete picture acknowledge the author's genius in compelling doubters and disbelievers to recognize themselves. In faithfulness in recording states of mind with which she does not agree she is comparable to George Eliot, and the purity of her motives is equally conceded by all critics. But the ideal religion which the work seems intended to proclaim is a mere ignis fatuus.

WARD, JOHN QUINCY ADAMS, one of America's most noted sculptors, was born at Urbana, Champaign co., Ohio, June 29, 1830. He spent about seven years in the studio of Henry K. Brown, and in 1857-58 he found employment in Washington in modelling busts of various prominent men. Since 1861 he has resided in New York, where he was elected a national academician in 1863. A bronze statuette, The Freedman, his first full-length figure, was executed in 1861, and won the admiration of the critics. The Indian Hunter, one of his best works, was first sketched out about 1857-8, and the sculptor subsequently went west to make further studies for this subject. The statue is in New York, where are also his Shakespeare; a colossal statue of Washington (1882); The Pilgrim; and some other works. He has executed a number of portrait statues, among them Commodore Perry (Newport, R. I.); Gen. Reynolds; one of the few good statues of Washington that we have (Newburyport, Mass.); and Gen. Geo. H. Thomas (Washington, D.C.), which ranks with the best equestrian statues produced in this country. He is also engaged on a statue of Henry Ward Beecher to be erected in Prospect Park, Brooklyn. His work is vigorous, characteristic, and original; it is, moreover, distinctively American in subject and spirit. (F. L. W.)

WARD, NATHANIEL (c. 1578-1653), author, was born at Haverhill, Suffolk, England, and educated at Emmanuel College, Cambridge. He practised law for some years, travelled on the continent of Europe, and had "distinguished associations." After holding a preachiership in London, he became rector of Standon Massey, in Essex, and was silenced by Archbishop Laud in 1633. Emigrating to Massachusetts, he was pastor at Agawam or Ipswich 1634-7, and bore a leading part in founding Haverhill in 1640. The General Court appointed him in 1638 to draw up a code, which was adopted in substance as the "Body of Liberties" 1641. That year he preached the election sermon, which Winthrop found rather classical than Biblical. His *Simple Cobbler of Agawam* (1647), written in Massachusetts, but published after his return to England, retains some reputation, and is praised by Prof. Tyler as "a medley of wit and humor," "the most eccentric and amusing" American book of the colonial era. It bore the name of "Theodore de la Guard," and was a satire on the politics, fashions, religious and other opinions of the age, marked by sincere bigotry and punning whimsicality. One of its queer statements is that "polypiety is the greatest impiety." Ward also put forth several pamphlets, preached before the House of

Commons June 30, 1647, became minister of Shenfield in Essex, and died there in 1653. J. W. Dean wrote a *Memoir* of him (Albany, 1868).

WARD, WILLIAM HAYES, editor, was born at Abington, Mass., June 25, 1835. He was educated at Phillips Academy, Andover, and at Amherst College, graduating in 1856. He studied theology in Union Theological Seminary and at Andover, graduating from the latter in 1859, and having in the meantime been tutor in Beloit College, Wis., for a year. He was pastor of a church at Oskaloosa, Kan., from 1859 to 1861, then became a teacher, and in 1865 was made professor of Latin in Ripon College, Wis. In 1868 began his connection with the *New York Independent*, of which he became superintending editor in 1871. Under his direction that journal has sought to foster genuine progress in theology and Christian union among all Evangelical denominations. It has also opened its columns to the representatives of all prominent movements, social and political, as well as religious. Dr. Ward has given special attention to Assyrian and Babylonian archæological studies, and he was director of the expedition to Babylonia, which was sent in 1884 at the expense of Miss Catharine L. Wolfe of New York city. He has contributed to the *Bibliotheca Sacra* and to the *Proceedings* of Oriental societies. With Mrs. Lanier he edited Sidney Lanier's *Poems* (1884).

WARE, HENRY (1764-1845), Unitarian theologian and controversialist, was born of poor parents on a farm at Sherborne, Mass., April 1, 1764, and assisted through Harvard by his brothers. After graduating in 1785, he taught for a time, and was ordained pastor at Hingham 1787. His election as Hollis professor of divinity at Harvard in 1805 opened the Unitarian controversy in New England, and caused the college to be given over by the orthodox. In 1816 Dr. Ware was made professor of Systematic Theology in the newly formed Divinity School. In 1839 he resigned his former chair in the college. He published *Letters to Trinitarians* (1820), an *Answer* (1822); and a *Postscript* (1823), in controversy with Dr. Leonard Woods, of Andover; *Inquiry into the Foundation, Evidences, and Truths of Religion* (2 vols., 1842), and some sermons. He died at Cambridge, July 12, 1845.

His son, HENRY WARE, JR. (1794-1843), also a theologian, was born at Hingham, Mass., April 21, 1794, graduated at Harvard 1812, and taught for two years at Phillips Academy, Andover. He was pastor of the Second Church in Boston 1817-29, having R. W. Emerson as colleague for the last year, and professor of pulpit eloquence and pastoral care at Cambridge 1829-42. He edited *The Christian Disciple* for some years from 1819, and contributed largely to periodicals. His poetical talents were early shown; a few of his hymns have been widely used. He published *Hints on Extemporaneous Preaching* (1824); *On the Formation of the Christian Character* (1831); a *Life of the Saviour* (1832); and *Scenes and Characters Illustrating Christian Truth* (2 vols., 1837). He died at Framingham, Mass., Sept. 22, 1843. An edition of his works in 4 vols. appeared 1846-7, and his *Memoir* by his brother, in 2 vols., 1846; the latter was surpassed in popularity by that of his wife, *Mary Lovell Ware* (1798-1849), by E. B. Hall, 1852.

His brother, WILLIAM WARE (1797-1852), the most brilliant of the family, was a Unitarian pastor in New York 1821-36, and won much reputation by his classical novels, *Zenobia* and *Aurelium*; these first appeared as *Letters from Palmyra* (1836-7); and *Probus* (1838). He also published *Julian* (1841); *Sketches of European Capitals* (1851); *Works and Genius of Washington Allston* (1852), and some sermons. His later years were spent mostly at Cambridge, where he died Feb. 19, 1852.

WARMING. See VENTILATION.

WARNER, CHARLES DUDLEY, author, was born Sept. 12, 1829, at Plainfield, Mass. On his father's death, the boy, then only five years old, went to live

with a relative at Charlemont. Here he remained till he was 13, as he tells in his *Being a Boy*, living the life of a typical farmer's boy, while his toils were lightened by a warm love for nature. In 1842 his mother removed to Cazenovia, N. Y., where he attended the Oneida Conference Seminary and was prepared for Hamilton College, where he graduated in 1851, taking the prize for the best English essay. He began to contribute to the *Knickerbocker*, and, soon thereafter, to *Putnam's Magazine*. Two years later he edited a *Book of Elegance*, which was published at Cazenovia, and then formed a plan for publishing a monthly magazine in Detroit. This miscarried, and he joined a surveying party on the Missouri frontier. Returning to New York city, he studied law, mainly in the Astor library, and in 1856 was admitted to the bar in Philadelphia, and practised in Chicago till 1860. He then became assistant-editor, and subsequently editor, of the Hartford (Conn.) *Press*, and soon went with the *Press* to the *Courant*, becoming assistant editor and part-proprietor. In 1868-9 he spent 14 months in Europe, and his *Scatterings* is the outcome of his tours there. His reputation began with the republication of a series of papers called *My Summer in a Garden* (1871). His later writings include *My Winter on the Nile*; *In the Levant*; *Washington Irving*; *A Roundabout Journey*; *Life of Captain John Smith*; *The American Newspaper*; *Mummies and Moslems*; and *Their Pilgrimage* (1886). In conjunction with S. L. Clemens ("Mark Twain") he also produced *The Gilded Age* in 1873. He resides in Hartford, Conn., and is one of the editors of *Harper's Magazine*. Warner belongs to the meditative school of literature, with a seasoning of humor and quaintness. His philosophical playfulness reminds us of Holmes, his quaintness suggests Lamb, and the placidity and purity of his style recall Washington Irving. "His works have a surface of smiles," says William A. Rideing, "but under the smiles lie deep thoughts."

WARNER, SETU (1743-1784), colonel in the Revolutionary war, was born at Roxbury, Conn., May 17, 1743, son of Dr. Benjamin Warner. From his youth up he was distinguished for his sound judgment, energy, and courage—moral as well as physical. In 1765, with his father, he removed to Bennington in the New Hampshire Grants (now Vermont), the territory being in dispute between the States of New York and New Hampshire. During the contest Warner and Ethan Allen (*q. v.*) were the leaders of the settlers on the "grants" and the champions of their rights, for which they were outlawed by the State of New York and a reward offered for their arrest. On the outbreak of the Revolutionary war Warner and Allen led the "Green Mountain Boys" to the capture of Ticonderoga, May 10, 1775, and on the next day Warner captured the important post of Crown Point with 113 cannon. Both were made colonels by the settlers and recognized as such by the army in the invasion of Canada. In the siege of St. John's (where Allen was captured) Col. Warner took part under Montgomery, and defeated Gen. Carleton in the attempt for its relief. When Ticonderoga, on the approach of the English under Burgoyne, was evacuated on the night of July 6, 1777, the main body of the American army took the road through Hubbardton and Castleton, Warner's regiment and another constituting the rear guard. When attacked next day by Gen. Frazer with the *élite* of the British army, Warner maintained a stubborn resistance till overwhelmed by Hessian reinforcements. Few actions in the war were more obstinately fought, and for his gallantry here and other services Warner was offered the rank of brigadier-general by Washington, but declined acceptance on the ground that his education did not qualify him for the position. At the battle of Bennington Col. Warner arrived too late to take part in the successful assault upon *Baun's* defences, yet in

season to repel the enemy's reinforcements advancing under Breyman and to share in the glory of the exploit. During the remainder of the campaign till Burgoyne's surrender Warner was constantly on the alert. For seventeen days he never took off his boots, and, in consequence, a disorder settled in his feet which proved incurable and disabled him for further service. He transferred his residence from Vermont back to his native Roxbury, and died there, Dec. 26, 1784. Col. Warner was of noble appearance, being 6 feet 2 inches in stature. His features were regular and indicative of mental strength and fixedness of purpose, and his manners at once pleasing and dignified.

WARNER, SUSAN (1818-1885), novelist and religious writer, was the daughter of a lawyer, who wrote some books of a political or patriotic character. Her earlier works, published under the name of "Elizabeth Wetherill," were very extensively circulated. *The Wide, Wide World* (1849) and *Queechy* (1852) were translated into French and German; of the former, meant for young girls, as were most of her books, 500,000 copies are said to have been sold in ten years. The French critic, Taine, read it and in his *History of English Literature* refers to it as a striking example that English and American novelists are "not artists but moralists. It is only in a Protestant country," he says, "that you will find a novel entirely occupied in describing the progress of moral sentiment in a child of twelve." But Miss Warner wrote books of other kinds. *American Female Patriotism*, a prize essay, appeared in 1852, and *The Law and the Testimony*, a compilation from Scripture, in 1853. Among her later fictions were *The Hills of the Shatemuc* (1856), *The Golden Ladder* (1862), *The Old Helmet* (1863), *Milbourne House* (1864), and *Daivy* (1868).

Her sister, ANNA WARNER, born in New York city, wrote originally under the name of "Amy Isthrop." *Dollars and Cents* appeared 1852, *My Brother's Keeper* (1855), *Stories of Vinegar Hill* (6 vols., 1871), *The Fourth Watch* (1872), *The Other Shore* (1873), and a small volume of *Wayfaring Hymns* (1869). Some of her translations from the German appeared without name in *Hymns of the Church Militant* (1858), which she compiled. In conjunction with her sister Susan she produced *Ellen Montgomery's Book-Shelf* (5 vols., 1853-9), *Say and Seal* (1860), which had a large sale, and *Wych Hazel* (1876), besides the *Word Series* (3 vols., 1868), and others of a religious character or intended for juvenile readers. The publications of the sisters were often in two volumes; the character was rather edifying than intellectual, and the earlier ones had the larger share both of literary merit and popular success. From about 1860 the sisters lived on Constitution Island in the Hudson, near West Point.

WARREN, GOVERNMENT KEMBLE (1830-1882), general, was born at Cold Spring, N. Y., Jan. 8, 1830, and graduated at West Point in 1850. Assigned to the corps of topographical engineers, he was employed in surveys in the West, and was the first to explore the district of the Black Hills. For four years, 1854-58, he was engaged in the construction of a map of the trans-Mississippi region, and contributed to the *Pacific Railroad Reports, Explorations in the Dakota Country*, and other government publications. He was assistant professor of mathematics at West Point from 1859 to the beginning of the civil war, which he entered as lieutenant-colonel of a Zouave regiment, the Fifth N. Y. At Big Bethel he brought off the body of Lieut. Greble. Becoming colonel Aug. 31, he was for some time employed in the construction department at Washington. After serving before Yorktown, he was in May, 1862, placed in command of the Third brigade of Sykes' division of Porter's corps (the Fifth), at the extreme right of the forces. He was engaged in all the actions of that campaign, and at Gaines' Mill, where he was slightly wounded, earned the brevet of lieutenant-colonel in the regular army and the commission of brigadier-general of volunteers. He went safely

through the battles of Malvern Hill and the second Bull Run, and at Antietam half his regiment were killed or wounded. He bore a part at Fredericksburg, and on Feb. 2, 1863, he became chief of topographical engineers on Gen. Hooker's staff, and June 8, chief engineer of the Army of the Potomac. In the midst of the war, June 17, he was married. On July 2 he held and defended Little Round Top, the key of the Union army's position at Gettysburg, where he received a slight wound. This was followed Aug. 8 by the commission of major-general of volunteers, dating from the battle of Chancellorsville, May 3. In August he had temporary command of the Second Corps, and in October repelled an attack by A. P. Hill at Bristow Station and received the brevet of brigadier general, with special praise from Gen. Meade. At Mine Run, Nov. 30, a movement was ordered by Meade which the changing circumstances of the field made impossible of execution without useless sacrifice of life: Warren in the exercise of a reasonable discretion disobeyed the order, and was sustained and commended by his superior officer for so doing. On March 24, 1864, when the army was being reorganized, he was placed in command of the Fifth Corps, which he led gallantly in the battles of the Wilderness, Cold Harbor, Petersburg, and minor engagements. His men trusted and loved him. Gen. Grant in his *Personal Memoirs* pronounces him "an officer of superior ability, quick perceptions, and personal courage to accomplish anything that could be done with a small command," but declares that his constitutional defect was an endeavor to superintend in person the execution of all his orders, and to guard against remote contingencies which his superior officer had probably otherwise provided for. At the outset of the campaign Grant thought of Warren as Meade's possible successor, but early in the next year Grant was so much dissatisfied with Warren's dilatory movements that he called Sheridan's attention to his serious defects and authorized him if Warren's "removal were necessary to success not to hesitate." On April 1, 1865, at Five Forks, Gen. Warren unfortunately ventured to exercise discretion as he had successfully done sixteen months before, but Gen. Sheridan, who had been impatiently waiting for Warren's arrival, at last sought him out and relieved him of his command. Being sent to Gen. Grant, he was put in command at Petersburg. This disgrace wounded Warren's spirit deeply and permanently; he afterwards defended his conduct in a pamphlet, but a court of inquiry sustained Sheridan. The brevet of major-general, bestowed "for gallant and meritorious services in the field," failed to console Warren, and public opinion was not inclined to meddle in a painful controversy between two officers of such eminence. The war was nearly over. After two weeks' service in the South-west he resigned his volunteer commission. He remained in the regular army, employed upon forts, harbors, bridges, etc., as a major of engineers. He died at Newport, R. I., Aug. 8, 1882.

WARREN, JOSEPH (1741-1775), a patriot of the American Revolution, the son of a farmer and descendant of an early settler at Boston, was born at Roxbury, June 11, 1741. After graduating at Harvard 1759, he studied medicine, and began to practise 1762, but zeal in the cause of liberty soon rendered him indifferent to bright prospects of professional advancement. The Stamp Act set him thinking, and his evenings were given to the study of the great questions then rising into prominence. By 1766 his opinions were formed, and they thenceforth ruled his actions; he gave himself heart and soul to American freedom, and labored with tongue and pen to bring others to his mind. He had every quality of a leader—popular manners, sweetness of temper, ready and vivid eloquence, intense energy, fearless ardor, and exquisite prudence. The plan for town meetings was drawn up in September, 1768, by Warren, Otis, and Samuel Adams. He was

active in the caucus which at first met secretly in private houses, but after 1773 in a hall, inviting the attendance and co-operation of workmen. Dr. Warren and Samuel Adams, intimately associated throughout, were the brains and soul of the early movement in Massachusetts; of the two, Warren was the more conservative—the slower to abandon hope of a peaceful settlement which should secure colonial rights. Acting for the Committee of Correspondence, they drew up in November, 1772, the two statements of these rights and of the violations thereof a year later. Warren was one of the committee to prevent the landing of the tea. The "Solemn League and Covenant," to suspend commercial relations with England, sent to every town in the province in June, 1774, was reported by him to the Committee of Correspondence. The progress of events had by this time made him ready for extreme measures. He told the Suffolk County Convention in September that "a sovereign who breaks his compact with his people forfeits their allegiance," and wrote to Quincy in November that if recent acts were not repealed, the two countries had better separate. He personally handed to Gen. Gage papers protesting against the fortifications then being built around Boston. Toward the end of 1774 he was at the head both of the Provincial Congress and the Committee of Safety, and practically dictator, but for the British troops. His disinterestedness and wisdom made him the safest depository of power and executive of the popular will. He restrained the enthusiasts who would have precipitated a local conflict, and insisted that the colonies must act together through the Continental Congress. March 5, 1775, he was a second time the orator on the anniversary of the Boston massacre. The church was crowded, and he entered by a window. British officers sat on the pulpit stairs, and one of them, at some ringing sentence, displayed bullets in his open hand, which Warren at once covered with his handkerchief. This was improved into the story of a pistol levelled at the speaker's head. Soon after he, with Hancock and Samuel Adams, was, by order of the ministry, excluded from the pardon offered to other malecontents. His tireless vigilance penetrated the secret of the British movement on Lexington, and sent Paul Revere (*q. v.*) and Dana thither by different routes to warn Adams and Hancock, thus making possible the initial victory of the war. He was present at the fight, and was said to have had a lock of hair cut off by a bullet. He urged the appointment of Washington as commander-in-chief in place of Artemas Ward, whom some favored for local reasons. Declining the post of surgeon-general, he accepted from Massachusetts, June 14, that of major-general. The occupation of Bunker Hill, ordered by the Council of War, he thought unwise, but insisted on taking part in the action there. A colleague in the Committee of Safety strove to dissuade him from this step, saying it was death to go. He replied: "*Dulce et decorum est pro patria mori.*" Arrived at the hill, he refused to take command, saying he came as a volunteer to learn from older soldiers, and asked to be shown the place of greatest danger. He fell, "the last in the trenches," as the retreat began, June 17, 1775. His death was a awful loss to the colonies, but his example stimulated and cheered patriotic zeal everywhere. No American, from the founders to that date, had been more prominent or more useful than he; no life was ever more freely consecrated to liberty or more cheerfully laid down. In the presence of such a memory as Warren's, cold analysis gives way to grateful and reverent affection. At all points he was the model of a patriot hero. His zealous abilities would have taken high rank in the councils of the young republic; but the poetic beauty of his character seems fitly crowned by an early and glorious death. His body was not recovered for a year. Congress voted in September, 1777, to erect a monument, but the column raised by the Freemasons in 1794 was the first to mark the spot.

On June 17, 1857, the Bunker Hill Monument Association unveiled a statue of Warren with imposing ceremonies. See R. Frothingham's *Life and Times of Joseph Warren* (1865). (P. M. B.)

WASHBURN, ELIHU BENJAMIN (1816-1887), diplomatist, was born at Livermore, Maine, Sept. 23, 1816, and passed an apprenticeship in the office of the *Kennebunk Journal*. In 1840 he removed to Illinois, and began to practise law at Galena. He was in Congress 1853-69—first as a Whig, then as a Republican. Of the latter party he was one of the organizers and leaders. He was chairman of the Committee on Commerce 1857-65, and of other committees, and was called the watch-dog of the Treasury. Though not acquainted with U. S. Grant till after the outbreak of the civil war, Washburne obtained for him a commission of brigadier-general in September, 1861, and was thenceforth his firm friend and efficient helper. On Grant's accession to the Presidency in 1869, Washburne became his Secretary of State, but held the post only a week, when he was sent as U. S. Minister to France. Here he won the greatest distinction of his life, and rendered conspicuous services to the cause of humanity. At the outbreak of war with Prussia in 1870, that government sought his protection for its citizens residing in Paris. He accepted the trust, and discharged it with rare tact, ability, and success. Respected and even trusted by the successive French authorities, he occupied a position of singular influence, and used it for the benefit of distressed and endangered foreigners. During the siege and the Commune, he was the only representative of foreign countries remaining, and the only person in Paris permitted to receive and send letters. By his means many Germans were enabled to communicate with their homes, or to pass thither in safety through the French lines, and to many others the horrors of that period were mitigated, though his efforts to save Darboy, the Archbishop of Paris, were fruitless. The gratitude of Germany for his services was often and warmly expressed. On leaving his post after eight years' tenure he went to Berlin to receive the public thanks of the Emperor. His later years were spent in Chicago. His *Recollections of a Minister to France*, 1869-77, appeared just before his death, which occurred Oct. 22, 1887.

Two of his brothers (all of whom spelt their name without the final e) were in Congress at the same time with himself, and otherwise attained distinction. ISRAEL WASHBURN, JR. (1813-83), was a representative from Maine 1851-60, governor 1861-63, and then collector at Portland. CADWALLADER GOLDEN WASHBURN (1818-82) emigrated to Wisconsin in 1841, was in Congress 1855-61 and 1868-72, entered the civil war as colonel, was a major-general of volunteers from 1862, governor of Wisconsin 1872-74, and a leading merchant in flour and lumber. Another brother, CHARLES AMES WASHBURN, born 1822, was an editor at San Francisco. He was sent in 1861 minister to Paraguay, where he had an eventful career, wrote a *History of Paraguay*, 1871, and invented the typograph and other instruments.

WATER MELON. See MELON.

WATER SUPPLY. Ever since cities were built and inhabited the question of water supply has engaged the attention of their people, and in early times fountains and springs were dedicated to the gods, who were supposed to keep them pure and undefiled; in ancient Rome the "Festival of Fontanalia" was annually kept, when fountains and wells were crowned with flowers and wreaths were cast upon the running streams. Aqueducts of wonderful magnitude, supported in some instances by three ranges of arches superposed, were built many centuries before the Christian era, and even at this day there may be seen similar grand conduits supplying the cities of the Old World. (See AQUEDUCTS.) In modern times

aqueducts depending upon gravity for the delivery of water have been superseded almost entirely by iron pipes, and where gravity is insufficient steam-power has taken its place, so that now we have the precious fluid not only bubbling and sparkling in our parks and fountains, but also brought to our very doors and delivered inside our dwellings. While we may boast of these modern inventions which the discoveries of the capabilities of steam and of iron have made possible, we yet fail to vie with the ancients in the purity or abundance of the water supplied to our great cities—Rome with its nine aqueducts was lavish in serving its people at the rate of over 300 gallons per diem for each man, woman, and child, while we are supposed to be contented with fifty.

The original source of all waters is found in the vast seas and oceans of the world, from whence it is drawn in perfect purity by the sun, and as vapor is wafted to the ends of the earth where accumulating and condensing in clouds, it falls as rain or snow and finds its way back to the seas and oceans—thus completing its cycle after furnishing its life-giving properties to all living creatures and things. In the United States, as in other countries, it is collected, stored, and distributed by means of wells, cisterns, reservoirs, aqueducts, and pipes, the smaller cities depending upon wells and cisterns, and the more populous upon reservoirs which are supplied from rivers, streams, lakes, and springs. In some instances, as at Chicago, Ills., what is known as the "pump and stand-pipe" system is employed, and at others, as Kansas City, Mo., the "direct" or "Holly system" is in use—in these systems no storage or other reservoirs are required, as the water is pumped directly into the stand-pipe or into the mains and thence distributed through the city. "Driven-wells" are an American invention and consist in driving into the earth a hollow tube fitted with a strainer properly protected and shod with a wedge-shaped end; the tube is usually 1½ inches in diameter and of convenient lengths for driving; each length is screwed into its fellow as it descends, the thread of the screw being protected by a cap which receives the blows of the hammer. Successive lengths of tubing are added until satisfactory water is reached, which is discovered by means of a pump applied at the top from time to time. These tubes are driven to a surprising depth, 40 to 250 feet, and as they are virtually a continuous pipe reaching to the supply, no contamination from surface water is likely to occur if sunk deep enough. Of course they cannot penetrate rock, but where available are much thought of and are growing in favor. Brooklyn, N. Y., is probably the largest city in which they are extensively used.

It is now understood that water from shallow wells is wholly unfit for drink and should never be used for that purpose without boiling, filtering, and aerating. The water from deep wells depends for its purity upon the strata through which it percolates—chalk formations furnishing the best. Flowing artesian wells of great depth (one at St. Louis, Mo., is 3800 feet deep) are found in geological basins, and frequently furnish a wholesome water in large quantities which can be supplied without pumps or engines. (See ARTESIAN WELLS.) More than 2000 years ago the Chinese bored for water very much in the same manner that we do to-day, by percussive action. By the use of a tower or stand-pipe the water from wells may be utilized where the flow-pressure is not sufficient; but wells, like cisterns, cannot be depended upon to supply the growing needs of cities. A number of cities in the United States are supplied from springs, notably Huntsville, Ala., in the South, Salem, Mass., in the North, Grand Rapids, Mich., in the West, and in the far West quite a number are thus supplied; this is probably the purest source of supply, as springs are now regarded as furnishing more wholesome water than rain itself.

In order that the water supply may be constant and

See Vol. XXIV, p. 402 (p. 429 Am. Rep.).

to guard against accident, it has been found necessary to provide storage; this is accomplished by means of reservoirs. (See RESERVOIRS in ENCYCLOPEDIA BRITANNICA.) The capacity of these receptacles is determined by the needs of the city, and it is found best to provide a series of reservoirs, not only to meet any emergency that may arise but also for the purpose of permitting the water which has been pumped into the initial receptacle to settle in the additional ones before it is turned into the mains and pipes for distribution. Filtration is also employed to free the water of impurities, and many systems have been adopted for this purpose, one of the latest being a proposal by a New York company of a plan by which the filter beds are erected over the reservoir and the water is pumped into the beds, whence it percolates into the reservoir below. Another is known as the "Hyatt pure water filter," so arranged that the water is filtered after it leaves the reservoir and before its distribution. While the construction of reservoirs requires engineering skill, the location with reference to the surroundings is one that should engage the attention of the sanitarian. The water may become contaminated while stored from the proximity of the reservoir to the cultivated or inhabited lands which surround it, or from fungi or other foreign substances which may grow or be thrown or fall into it. The sides should be well protected, and if the ground rises above it, that should be sodded and kept free from everything contaminating and objectionable, such as swine, cattle, or other stock, etc. The rainfall is an important factor in deciding the quantity of water that may be obtained from whatever source; it is estimated that one-third of the rainfall disappears by evaporation and the absorption of vegetation, one-third descends into the earth to reappear as springs or remains as subterranean reservoirs that may be tapped by wells; and one-third flows as rivers and streams or forms lakes and pools.

While the question of cost ought not to have controlling weight where health is concerned, it is well in determining between different sources of supply to examine into the relative cost of subsidence, precipitation, filtration, etc., as applicable to the several sources under consideration, always bearing in mind that rivers or streams receiving sewage or refuse of manufactories within a limit of twelve miles are never a proper source of water supply whether chemical analysis or biological research develop the existence of impurities or not.

Referring to the question of a pure water supply and the difficulty of determining whether organic matter is present or not, Prof. J. W. Mallet, F. R. S., in an exhaustive paper upon water analysis prepared by him for the National Board of Health United States (see N. B. II. Report, 1882, p. 207), in which he takes the ground above indicated, sums up the result of different processes of water analysis conducted by himself and other experts in the following general conclusions:

1. It is not possible to decide absolutely upon the wholesomeness or unwholesomeness of drinking water by the mere use of any of the processes examined for the estimation of organic matter or its constituents.

2. I would even go further, and say that, in judging the sanitary character of a water, not only must such processes be used in connection with the investigation of other evidence of a more general sort, as to the source and history of the water, but should even be deemed of secondary importance in weighing the reasons for accepting or rejecting a water not manifestly unfit for drinking on other grounds.

3. There are no sound grounds on which to establish such general "standards of purity" as have been proposed, looking to exact amounts of organic carbon or nitrogen, "albuminoid ammonia," oxygen of permanganate consumed, etc., as permissible or not. Distinctions drawn by the application of such standards are arbitrary and may be misleading.

4. Two entirely legitimate directions seem to be open for the useful examination by chemical means of the organic constituents of drinking water, namely: first, the detection of very gross pollution, such as the contamination of the water of a well by accidental bursting or crushing of soil-

pipes, extensive leakage of drains, etc.; and secondly, the periodical examination of a water supply, as of a great city, in order that, the normal or usual character of the water having been previously ascertained, any suspicious changes which from time to time may occur shall be promptly detected and their causes investigated.

5. In connection with this latter application of water analysis, there seems to be no objection to the establishment of local "standards of purity" for drinking-water, based on sufficiently thorough examination of the water supply in its usual condition.

6. With the facts of this investigation before me, I am inclined to attach special and very great importance to a careful determination of the nitrites and nitrates in water to be used for drinking.

7. If I had intrusted to me the charge of watching a large city's water supply I should use all three of the principal processes for the examination of the organic matter present; each gives a certain amount of information which the others do not afford.

Under circumstances admitting only of the use of simpler means of investigation, the albuminoid-ammonia and permanganate processes might be employed together, but in no case should one only of these methods be resorted to, such a course entailing practically the neglect of carbon on the one hand or nitrogen on the other.

The Vienna Water Commissioners give the following rules for determining healthy water:

1. Water must be clear, sparkling, colorless.
2. It must contain but a small quantity of solid materials and be entirely free of organized matter (infusoria).
3. Of the alkaline earths (CaO, MgO) it must not contain more than 18 parts by weight in 100,000 parts by weight of water.
4. It must contain but a small fractional part by weight of soluble salts, particularly the sulphates and nitrates.
5. The solids held in solution and the temperature of the water must vary within very narrow limits during the year.
6. It must be protected from contamination.
7. The above requirements are fulfilled in many cases by soft spring water, which alone is suitable for drinking purposes.
8. The industries require water having nearly the same properties.
9. Filtered river water, if at all times free of turbidity, will answer for technical purposes, but on account of not fulfilling requirements 5 and 6, is not fit for drinking.
10. To sprinkle or clean streets any water is suitable provided it is odorless and does not contain a great amount of offensive material.

A survey of the water supply of the cities of the United States and the manner of securing it, etc., is too comprehensive to be given in detail here; for complete statistics upon this subject, embracing all necessary information and covering 1688 cities and towns, the reader is referred to the *Manual of American Water-Works* just published (1889) by the *Engineering News*, New York, to whose editors the writer is indebted for the table showing the supply, etc., of several of the principal cities. (See p. 762.)

The number of towns having a water-supply for domestic use in the United States and Canada up to Jan. 1, 1889, and their geographical distribution is here given:

New England—Maine, New Hampshire, Vermont, Massachusetts, Rhode Island, and Connecticut.....	290
Middle—New York, New Jersey, Delaware, Pennsylvania, Maryland, District of Columbia.....	456
South Atlantic—Virginia, West Virginia, North Carolina, South Carolina, Georgia, and Florida	73
South Central—Alabama, Mississippi, Louisiana, Tennessee, Kentucky	57
North Central—Ohio, Indiana, Michigan, Illinois, Wisconsin.....	330
North Western—Iowa, Minnesota, Kansas, Nebraska, Dakota, Montana, Wyoming.....	222
South Western—Missouri, Arkansas, Texas, Colorado, New Mexico.....	180
Pacific—Washington, Oregon, California, Arizona, Nevada, Utah, Idaho.....	130
United States, Total.....	1688
Canada.....	78

Abstracted from the "Manual of American Water-Works," published by the "Engineering News," New York.

Towns.	Population, 1880, est.	Constructive.	Capacity reser-voirs, gallons.	Daily consumption, gallons.	Source of supply.	Mode of supply.	Pipe miles.	Pipe material.	Service pipe.	Remarks.
New York city.	1,700,000	1744, 1799, 1841	18,385,000,000	110,000,000	Drainage areas of Croton and Bronx Rivers, Schuylkill and Delaware Rivers and springs, Surface-water from streams open and driven wells, Lake Michigan.	Gravity, with pumping to stand-pipe for high service, Pumping to reservoirs and direct, Pumping to reservoirs, Direct pumping, Pumping through stand-pipe and distribution system to reservoir.	620	Cast-iron.	Lead.	Wrought-iron and lead service.
Philadelphia, Pa.	1,000,000	1801	373,000,000	85,000,000			876	"	"	"
Brooklyn, N. Y.	770,000	1859	1,180,000,000	46,000,000			307	"	"	"
Chicago, Ill.	770,000	1854	None.	For 1886 91,000,000			638	"	"	"
St. Louis, Mo.	449,000	1867	60,000,000	31,000,000	Mississippi River.	Gravity, with pumping to high service.	314	"	"	Cast-iron, wrought-iron, and cement mains. Includes Chabon, Evered, and Bonerville.
Boston, Mass.	400,000	1632, 1796, 1845, 1894, 1878	5,373,000,000	37,000,000	Lake Cochichewick, Sudbury River, and Mytic Lake, Jones Falls and Gunpowder River.	Gravity, with pumping for high service.	664	"	"	"
Baltimore, Md.	400,000	1807, 1863	Estimated 1,000,000,000	34,000,000	Ohio River.	Pumping to reservoir and tank.	358	"	"	"
Cincinnati, Ohio.	275,000	1820	109,000,000	32,000,000	Ohio River.	Gravity, with a little pumping to reservoir.	217	"	"	"
San Francisco, Cal.	250,000	1839	At all 130,000,000	19,000,000	Mountain streams.	Pumping to reservoir, stand-pipe, and direct.	250	"	"	"
New Orleans, La.	240,000	1833	4,500,000	6,000,000	Mississippi River.	Pumping to reservoir.	72	"	"	"
Cleveland, Ohio.	220,000	1856, 1874	1210 0.0.0	22,000,000	Lake Erie.	Pumping to reservoir.	252	"	"	Galvanized-iron and lead service. Owned by U. S. government. Includes Georgetown, D. C.
Washington, D. C.	200,000	1839	About 63, 000,000	26,000,000	Potomac River.	Gravity, with pumping to reservoir and direct for high service.	128	"	Galv. iron.	"
Pittsburg, Pa.	215,000	1826, 1841, 1878	120,000,000	30,000,000	Allegheny River.	Pumping to reservoir.	175	"	Lead.	"
Buffalo, N. Y.	251,000	1812	14,000,000	38,000,000	Niagara River.	Pumping to reservoir and direct.	250	"	"	"
Newark, N. J.	160,000	1800, 1807	45,000,000	13,000,000	Passaic River.	Pumping to reservoir.	161	"	"	Galvanized-iron and lead service. Owned by city and a company.
Louisville, Ky.	165,000	1860	110,000,000	10,000,000	Ohio River.	Pumping to reservoir.	137	"	"	"

The largest system in the United States is in New York city, with an estimated population of 1,700,000 and daily consumption of 110,000,000 gallons, and with reservoir capacity of 18,385,000,000 gallons. With its new aqueduct it will have a daily supply of 500,000,000 gallons. The smallest system is at Drewsville, N. H., with a population of 90 souls. It has a gravity supply without reservoir, and

the daily consumption is unrestricted in amount. The great cities of New York, Brooklyn, Philadelphia, and Chicago are contemplating increasing their supply to meet their increasing wants. Philadelphia will more than double hers within a year, and when the third section of the East Park reservoir is completed the storage capacity will be 900,000,000 gallons. Chicago has Lake Michigan at its feet, and it is only a question of duplicating its present method or otherwise providing for furnishing an abundant supply. New York has sufficient water for the present in its supply from Croton and Bronx rivers, but its aqueducts are too small and are now being enlarged and increased. A proposition has been made by John R. Bartlett and associates of New York and New Jersey to furnish New York city, independent of the Croton water-shed, an ample quantity of pure and wholesome water from the lake regions of New Jersey. This proposition contemplates supplying Montclair, Newark, Jersey City, and surrounding towns in New Jersey, as well as New York city and Brooklyn, the plan being to collect all the available waters in the Passaic water-shed, including Greenwood Lake, and storing them in convenient reservoirs. These waters will then be conducted in pipes or in a permanently constructed aqueduct to the Jersey City shore of the Hudson River; tunnelling the river, the water will be delivered in the lower portion of New York city with a head-pressure of at least 300 ft. It will also be conducted across to Brooklyn in the same manner. It is claimed that by this combination plan all interstate questions can be avoided and riparian rights protected, and in addition there will be ample quantities provided for all the cities and towns of New Jersey that are dependent on the Passaic water-shed for their supply. The tunnel from Jersey City to New York is over one-third completed and can be finished in two years. The advantage of a double source of supply for New York city in case of war or serious accident to its present sources requires no argument.

The water supply of cities and towns, it is now generally believed by sanitarians, ought to be placed under the supervision of an intelligent board of health and furnished by a responsible company instead of owned and operated by the city. A properly constituted board to watch and investigate the condition of the water from time to time, and a company which could be held responsible for the quality and quantity of the water furnished, would be a great step in securing a wholesome and abundant supply of uncontaminated water. It is claimed that the system which prevails in many of our large cities, whereby the city water-works are made a means for political preferment instead of a source of comfort to its inhabitants, soon becomes a power for evil almost incalculable. (P. H. B.)

WATSON, EUKANAU (1758-1842), author and promoter of internal improvements, was born at Plymouth, Mass., Jan. 22, 1758, and apprenticed at 15 to a merchant of Providence, R. I. In 1779 he was sent to Southern ports to purchase cargoes for European shipment. His notes give historically valuable descriptions of Charleston and other towns. In 1779 he carried despatches to Franklin in France, engaged in business at Havre, and suffered reverses in 1782. His account of a *Tour in Holland in 1784* was published at Worcester, Mass., 1790. After 4 years in North Carolina, he settled at Albany in 1789, and soon after examined the Mohawk valley with reference to a canal, and urged the project upon Gen. Schuyler and the legislature. A *Vindication of Watson's claim to paternity for the idea*, by R. Troup, appeared at Geneva in 1821. A canal company was incorporated in 1792, though nothing was really done till much later. Watson showed equal energy and public spirit in furthering river navigation, routes of land travel, and public education. His home was at Albany till 1807, then at Pittsfield, Mass., till 1816, when he returned to Albany. At both places he founded agricultural

societies; of these he wrote a history, published 1820. His *History of the Western Canals* appeared the same year. After a journey to the lakes and down the St. Lawrence, in the interest of internal navigation, he removed to Port Kent, N. Y., in 1828, and died there Dec. 5, 1842. *Men and Times of the Revolution*, taken from his journals and correspondence, and edited by his son, appeared 1855. Both by his writings and by the enterprises which he forwarded, and for which he did much to prepare the way, Watson made contributions to American history. His remarkable predictions made in 1815 in regard to the increase of population in the United States down to 1900 are commented upon by Prof. Francis A. Walker in the article on the UNITED STATES in the ENCYCLOPÆDIA BRITANNICA.

WATSON, JAMES CRAIG (1838-1880), astronomer, was born in Elgin county, Ontario, Canada, Jan. 28, 1838. His parents, however, were citizens of the United States, and he was soon taken to Michigan. He graduated at the University of Michigan, Ann Arbor, in 1857, and for the next two years was assistant there in the Observatory. He acted as professor of astronomy during the absence of Prof. Brünnow till 1860, and then as professor of physics till 1863, when he took permanently the chair of astronomy in the University and directorship of the Observatory, which he relinquished 1879 to accept same positions in the University of Wisconsin. He died at Madison, Nov. 23, 1880. He was one of the most distinguished American astronomers. In his 19th year, on April 29, 1856, he discovered a comet, and his computation of the orbit of the comet of 1858 (Donati's) is considered authoritative. He was thrice deputed by the U. S. government to observe solar eclipses—in 1869 to Iowa, in 1870 to Sicily, and in 1878 to Wyoming—and in 1874 to Peking, China, to observe the transit of Venus. His original planetary discoveries amount to 23. He was a member of the National Academy of Science, and other learned bodies. He received the degree of Ph. D. from the University of Leipzig 1870 and from Yale College 1871, and the degree of LL. D. from Columbia College in 1877. The Lalande gold medal was awarded to him by the French Academy of Sciences in 1870 for the discovery of six new planets in one year. He was for some years actuary of Michigan Mutual Life Insurance Company. His considerable fortune he willed to the National Academy of Science. His genius was that of originality, though he claimed it not. His intuitions escaped "the ordinary processes of calculation, and gave him a masterly command of mathematical logic and formulæ." His work, *Theoretical Astronomy* (Phila., 1869), was at once accepted as a text-book at Leipzig, Paris, and Greenwich. His literary contributions are in *American Journal of Science*, Brünnow's *Astronomical Notices*, Gould's *Astronomical Journal*, and foreign astronomical periodicals. He published also *Popular Treatise on Comets* (Phila., 1860); *Report on Horological Instruments*, to the Centennial Exposition (1876), and *Tables for the Calculation of Simple and Compound Interest* (1878). (J. w. w.)

WATTERSON, HENRY, journalist, was born at Washington, D. C., Feb. 16, 1840, his father, the Hon. Harvey M. Watterson, being then a Democratic representative in Congress from Tennessee. On account of his defective eyesight young Watterson was educated chiefly by tutors at home. At a very early age he became dramatic and literary critic for the *States*, a Washington journal. At the age of 18 he became editor of the *Washington Democratic Review*, but in 1861 he returned to Tennessee to assume the editorship of *The Republican Banner* at Nashville. Shortly after the commencement of the civil war he entered the Confederate service, remaining in it till the close of the struggle with the exception of one year, during which he edited the *Chattanooga Rebel*. At the end of the war he returned to Nashville and revived *The Republican Banner*, and then removed to

Louisville to undertake the editorship of the *Louisville Journal*, in which he had purchased an interest. In 1868 this paper was consolidated with two others into the *Courier-Journal*, of which he continues to be editor. It has become one of the foremost organs of the Democratic party in the South. Mr. Watterson was temporary chairman of the National Democratic Convention of 1876, and he was a member of Congress from August, 1876, to March, 1877. He is an able political writer, a brilliant and incisive orator, and an uncompromising advocate of free trade.

WAYLAND, FRANCIS (1796-1865), president of Brown University, was born in New York city, March 11, 1796. His parents, who were of English birth, removed to Poughkeepsie, N. Y., in 1807. He graduated at Union College 1815, studied medicine and divinity, entered the Baptist ministry, and was a tutor at his *alma mater* 1817-21. For the next five years he held a charge in Boston, and there won great reputation by a sermon on *The Moral Dignity of the Missionary Enterprise* (1823), and two on *The Duties of an American Citizen*. In 1826 he returned to Union College as professor of mathematics and natural philosophy, but left it in February, 1827, for the presidency of Brown University, which he held for 28 years with distinguished success. He anticipated some of the chief educational reforms of our day in his *Thoughts on the Present Collegiate System in the United States* (1842), which favored a freer and more practical curriculum for students of non-professional aims. His *Report* for 1850 shows that these views had to some extent been embodied in changes of the course of studies at Brown the preceding year. As a maker of text-books (which embodied his class lectures) he stood in the front rank. Of his *Elements of Moral Science* (1835) 90,000 copies had been sold in 1868, besides sundry editions in England, and translations into foreign languages. His *Political Economy* (1837) attained a circulation about half as great. Both these were used in the Sandwich Islands in a native version. His *Intellectual Philosophy* (1854) was less successful but is still in the market. Dr. Wayland retained his eminence as a preacher and published *Sermons* (3 vols., 1833, 1849, and 1858), besides *Salvation by Christ* (1859), and *Notes on the Principles and Practices of the Baptist Churches* (1857), the last being reprinted from the *N. Y. Examiner*. He was easily the leader of his denomination in America. Among his other works are *Limitations of Human Responsibility* (1838); *Letters on the Ministry* (1863), and memoirs of Harriet Ware (1850), Dr. A. Judson (1853), and Dr. Chalmers (1864). He was very active in the cause of free libraries and public schools in and beyond his own State; he founded the American Institute of Instruction, and was long its president; and he did much for prison reform and other benevolent enterprises. Concerning slavery his position was early and clearly defined; a correspondence between him and Dr. Richard Fuller (q. v.), of Beaufort, S. C., appeared in 1845. He resigned the presidency of Brown in 1855, but continued to preach and write. He died at Providence, Sept. 30, 1865. See *Memoir* by his sons (2 vols., 1869).

WAYNE, ANTHONY (1745-1796), general, was born Jan. 1, 1745, in Chester co., Pa. His grandfather and father had seen service and his own youthful inclinations were strongly military. He was sent to school in Philadelphia, became a surveyor, and spent a year, 1765-66, in Nova Scotia. He was a member of the Pennsylvania provincial legislature in 1774 and of the Committee of Safety in 1775. Soon after he raised a regiment, was commissioned colonel in January, 1776, and sent in April to Canada. At Three Rivers, in June, he distinguished himself and was wounded. He had command at Ticonderoga for six months, was made brigadier-general May 21, 1777, and joined Washington in New Jersey. He rendered efficient service at the Brandywine, Sept. 11; having

command of the left wing, he opposed the passage of the British throughout the day, and led his men safely off at evening. On the 16th an action which he commenced was cut short by a storm. On the 20th he was surprised at Parker's Ferry and forced to retreat with some loss; he demanded a court-martial, which honorably acquitted him. In the battle of Germantown, Oct. 4, he commanded the right wing, but mistakes or accidents occurred, and he retreated with no new laurels. In the following months he was of much service in foraging, crossing into New Jersey and procuring cattle and provisions for the army. At Monmouth, June 28, 1778, he bore a prominent part and was praised by Washington. His most brilliant exploit was the storming of Stony Point, N. Y., July 15, at night, only bayonets being used; for this he received the thanks of Congress and a gold medal. His popular title was "mad Anthony." Fortune favored him with no more such opportunities as this. He suppressed a mutiny of Pennsylvania troops in New Jersey in January, 1781. At Green Spring, Va., July 6, he suddenly encountered the enemy and retired; accounts of this affair are conflicting. After Cornwallis' surrender he was sent to Georgia, where he cleared the State (except Savannah) of the enemy; the Legislature voted him thanks and a farm, on which he lived for some years. Whatever his degree of prudence, his gallantry had earned more than the brevet of major-general. He was a member of the Pennsylvania convention which ratified the constitution in 1789, and in 1791 claimed a seat in Congress from Georgia, but lost it. In April, 1792, he succeeded St. Clair in the command of the Western army in Ohio, which sadly needed recruits, supplies, organization, and discipline. After two years of preparation and negotiation he attacked the Indians at Maumee Rapids, Aug. 20, 1794, and won a brilliant victory; the treaty of Greenville was made the following year. Wayne was returning to the East when he died at Presque Isle, on Lake Erie, Dec. 15, 1796. His remains were interred at Radnor, Pa., and there a monument was erected by the Society of the Cincinnati, July 4, 1809. H. N. Moore published a memoir of him (1845). (F. M. B.)

WEED, THURLOW (1797-1882), journalist and politician, was born at Acra, Greene co., N. Y., Nov. 15, 1797. He had no early advantages but such as come from the discipline of hardship; he was a cabin boy on the Hudson at 10, and began to learn the printer's trade at 12. From one office he moved to another, and in the war of 1812 he served on the frontier. At 20 he was editing the *Agriculturalist* at Norwich, N. Y. From this time he was always connected with some newspaper. In 1826 he was sent to the Legislature, and as editor of the *Anti-Masonic Inquirer* at Rochester took part in the agitation of that time (stirred up by the Morgan murder), and helped to re-elect De Witt Clinton to the governorship. In 1830 he was again in the Legislature and placed in charge of the Albany *Evening Journal*, then started by the party opposed to "the Regency" and to Pres. Jackson. His life for the next 32 years was bound up with this paper and with New York politics, in which he became a mighty power. He was a master of the art of handling voters and managing conventions; he was said to have once turned a State election at the last moment by the dexterous use of a moderate sum. Yet he was personally incorruptible and disinterested; he neither sought nor accepted office for himself; he was loyal to his party and his country and so indifferent to his own fortunes that friends looked after his financial affairs with eminent success. With Seward and Greeley he constituted a State triumvirate. While the former was governor, 1839-43, Weed was considered by many a power behind the throne. Though New York was especially his province, he did not neglect national affairs, but assisted in nominating successively Harrison, Taylor, and Scott. His zeal for the Whig party was transferred to the Republican; he strove to make

Seward a presidential candidate in 1856 and 1860, but, mastering his disappointment, earnestly supported Fremont and Lincoln. The latter sent him to Europe on an unacknowledged mission in the autumn of 1861, and the next year he ceased to conduct the *Journal*. Removing to New York in 1865, he edited the *Commercial Advertiser* for three years. After that, his activity, though continued, was concealed: a new race of managers had arisen, and at Saratoga in 1876 he was warned to abstain from interference. He published *Letters from Europe and the West Indies* (1866), and contributed some *Reminiscences* to the *Atlantic Monthly* in 1870. In his old age his sight almost totally failed. He died in New York, Nov. 22, 1882, leaving an *Autobiography*, which was edited by his daughter, and appeared at Boston 1883 (2 vols.). To this was added in 1884 a *Memoir* by his grandson, T. W. Barnes. (F. M. B.)

WEEVL. See AGRICULTURE, Chap. IX.

WEIR, ROBERT WALTER, artist, was born at New Rochelle, N. Y., June 18, 1803. He was engaged in mercantile pursuits until nearly twenty years of age, and then adopted art as a profession, studying under Jarvis, and painting for some time in New York. About 1824 he went to Italy, where he remained for several years. In 1828 he became an associate of the National Academy, and in 1829 he was elected an academician. Three years later he was appointed professor of drawing in the West Point Military Academy, a position which he held for 42 years. His works include portraits, genre pictures, and historical compositions, and he is noted especially for the faithful rendering of the accessories, the still-life in his pictures. Among his best-known paintings are *The Belle of the Carnival* (1836); *Landing of Henry Hudson* (1842); *Embarkation of the Pilgrims* (1845), in the rotunda of the Capitol, Washington; *The Evening of the Crucifixion* (1867); *Christ in the Garden* (1873); *Our Lord on the Mount of Olives* (1877); *Columbus before the Council of Salamanca* (1884), and various portraits, including one of Red Jacket, painted for Dr. J. W. Francis.

His sons have also gained an honorable position among our artists. JOHN FERGUSON WEIR, born at West Point, N. Y., Aug. 28, 1841, studied under his father. In 1861 he opened a studio in New York, where he became a National Academician in 1866. After spending a year in Europe he was, in 1869, appointed director of the Yale School of Fine Arts. He was also appointed judge of the fine arts at the Philadelphia Exhibition in 1876. His vigorous style is perhaps best shown by such strong work as *Forging the Shaft* (1868), which was burned, but of which a replica was exhibited at Paris in 1878. He has painted also portraits of S. Wells Williams and others, and in 1834 executed a statue of Benjamin Silliman.

JULIAN ALDEN WEIR, born Aug. 30, 1852, at West Point, N. Y., also studied under his father, and later (1872-76), under Gérôme, in Paris. He was elected a National Academician in 1886, was one of the founders of the Society of American Artists, and is also a member of various other societies. His works include *Breton Interior* and various other Breton subjects; *The Good Samaritan* (1881); and portraits of R. W. Weir (1880); Olin L. Warner (1881); Richard Grant White (1883); Peter Cooper (1884); and John Gilbert (1888). He has been the recipient of various honors at home and abroad, notably honorable mention at the Salon of 1881 for his portrait of Warren Delano, and the prize at the 4th Prize Fund Exhibition of the American Art Association, New York, for his *Idle Hours*. (F. L. W.)

WELLES, GIDEON (1802-1878), statesman, was born at Glastonbury, Conn., July 1, 1802, being descended from Thomas Welles, a colonial governor. He was educated at Norwich University, studied law and in 1826 became editor and proprietor of the *Hartford Times*, in which he advocated the election of

Gen. Jackson to the Presidency. He entered the State Legislature in 1827 and served there for eight years. In 1836 he was made postmaster of Hartford and soon after gave up the management of his newspaper, though he continued to be an active contributor to the press. In 1842 he was made State comptroller. From 1846 to 1849 he was in Washington as chief of a bureau in the navy department. During the Kansas-Nebraska troubles Welles, who had heretofore been an ardent Democrat, opposed the extension of slavery and when the Republican party was formed was one of its earliest adherents. As chairman of the Connecticut delegation to the Chicago convention, in 1860, he contributed to the nomination of Lincoln to the Presidency and was called by the latter to be his secretary of the navy. The civil war greatly enlarged the scope and duties of this department, but Secretary Welles conducted it with unflinching zeal, industry, and efficiency. He maintained along 2000 miles of coast a blockade as effective as the circumstances would permit, organized on the Mississippi River a fleet of ironclads and transports, sent out well-equipped expeditions to various points, and in various ways contributed to the numerous victories which added to the renown of the American navy. After the war was over, Welles remained in Pres. Johnson's cabinet, and supported his policy of reconstructing the Southern States, thereby losing favor with the Republican party. After his retirement he published "Memoirs of the War" in the *Galaxy*. He died at Hartford, Feb. 11, 1878.

WELLESLEY COLLEGE, a noted institution for the higher education of women, is in the beautiful village of Wellesley, Norfolk co., Mass., about 15 miles west of Boston. It was founded by Mr. Henry F. Durant, who in 1855 purchased here 300 acres of land, which he improved as a park. In 1875 the college hall, which had been carefully built under his supervision, was opened. It is 475 feet long and 150 feet wide at the wings. It is built of brick with free-stone trimmings, and is four stories high, but in some parts a fifth story is added, which serves as a studio and museum. Besides this building there are now a College of Music, Waban Cottage, Simpson Cottage, Stone Hall, Norumbega, Freeman Cottage. Wellesley has valuable collections of paintings and statuary, which are distributed through the rooms and halls. The library has 25,000 volumes. There are chemical, physical, biological and botanical laboratories, and the rooms used for scientific work have their appropriate collections of books. The college gymnasium was fitted up under the direction of Dr. Dudley A. Sargent, of Harvard University. Adjoining the college grounds is Lake Waban, on which 14 boats are used in summer. Entertainment in winter is furnished by concerts and lectures. The course of study is similar to that pursued in American colleges, but special opportunity is given for the study of art and music. Care of the rooms and halls is required of the students, who thus are taught the art of housekeeping, though they do not perform heavy work. At the opening of the college in 1875, provision had been made for 300 students, but 314 were enrolled in the first year. There were then 28 instructors and officers, Miss Alice E. Freeman being the president. She retired from this position in 1888 on her marriage to Prof. F. Palmer, of Harvard University. There are now 75 instructors. The first graduating class numbered 18 and that of 1888 numbered 60. The total number of students enrolled exceeds 2300, and the graduates 300. Besides Mr. and Mrs. Henry F. Durant, the principal benefactors of the college have been Mr. M. H. Simpson, Mrs. Valeria G. Stone, and George Smith.

WELLSHAUSEN, JULIUS, German theologian, was born at Hameln-on-the-Weser, May 14, 1844. He was educated at Göttingen under Ewald, and there began to lecture on theology in 1870. He was made ordinary professor at Greifswald in 1872, but resigned in 1882 on account of his divergence from Protestant

theology. He then entered the philosophical faculty at Halle, and in 1885 accepted a similar position at Marburg. Among his publications are *Tect der Bücher Samuels* (1871); *Plurivser und Sadduceer* (1874); *Prolegomena zur Geschichte Israels* (1878); *Skizzen und Vorarbeiten* (2 vols., 1884-85). Wellshausen has been the most prominent advocate and exponent of the reconstruction of the history of Israel by higher criticism of the Old Testament. He wrote the article on "Israel" and other articles in the *ENCYCLOPÆDIA BRITANNICA*.

WELLS. See ARTESIAN WELLS and WATER SUPPLY.

WELLS, DAVID AMES, economist, was born at Springfield, Mass., June 27, 1827. He graduated at Williams College in 1846, and at the Lawrence Scientific School, Cambridge, in 1851, where he was immediately made assistant professor. In 1853 he was engaged with Dr. A. A. Hayes, in Boston, in practical chemistry, and in 1856 he obtained patents for improvements in bleaching. He was afterwards connected with a publishing firm in New York, and edited the *Springfield Republican* for a year. In 1862 he was sent to Europe on a special commission, and from 1866 to 1870 he was a commissioner of the revenue, and produced several very valuable reports. He had now become one of the most pronounced advocates of free trade, and as such received high honor in Europe, being made D. C. L. by the University of Oxford in 1874 and foreign associate of the French Academy of Political Sciences. He has also been prominent in the movement for civil service reform. He assisted in preparing a *History of Williams College* (1847); and edited the *Annual of Scientific Discovery* from 1850 to 1865. He also published *Familiar Science* (1856); *Science of Common Things* (1856), and other popular manuals on natural philosophy, chemistry, and geology; *Practical Economics* (1885); *A Study of Mexico* (1887); and treatises on tariffs and money.

WELLS, HORACE (1815-1848), one of the discoverers of anæsthesia, was born at Hartford, Windsor co., Vt., Jan. 21, 1815. He studied dentistry at Boston and began to practise it at Hartford, Conn., 1836. Moved by the suffering attending some dental operations, he expressed in 1840 the idea that they might be rendered painless by inhaling nitrous oxide gas. In December, 1844, he attended a lecture on "laughing gas," and noticed that a person to whom the gas was administered, meeting with an accident while under its influence, was unconscious of his hurts. Next day he put this discovery to personal proof by having a molar drawn while under the influence of that gas. From that time he used it in his practice and other Hartford dentists followed his example. Early in 1845 he went to Boston, explained his discovery to Dr. J. C. Warren's class and attempted to demonstrate, but unluckily removed the gas too soon and the experiment failed and he, discomfited, was ill for weeks. W. T. G. Morton, formerly his pupil and partner, got the idea from him but was persuaded by Dr. C. T. Jackson to use sulphuric ether instead of nitrous oxide, and applied it in October, 1846, in surgical as well as dental operations. He and Jackson then published and patented their discovery of "letheon" as an anæsthetic and presently quarrelled, each claiming the sole honor from the French Institute. Wells sailed for France in December and his claims were recognized by resolutions of the Medical Society of Paris after three days' discussion. On his return in March, 1847, he put forth a *History of the Discovery*, but the embittered controversy and experiments with chloroform were too much for his bodily and mental health. He went to New York, but became insane and committed suicide Jan. 24, 1848. Hartford erected a statue of Wells in its park and saluted him as the discoverer of anæsthesia, but this honor must be divided. Priestley discovered nitrous oxide gas in 1790, and Sir H. Davy in his *Researches* (1800) proclaimed a belief that it could be

used in surgery. The properties of sulphuric ether were known for the same period and played with by college boys. Dr. Crawford W. Long, of Georgia, used it in his practice in 1842, but never published this application till after it was made and announced by others. Dr. Marey, of Hartford, a friend of Wells, in January, 1845, performed a successful operation by its aid; but Dr. Morton appears to have been the first to realize its importance for this use, and to seek and gain the credit of its introduction. Flourens, of Paris, showed the anæsthetic effect of chloroform on animals in January, 1847, and in November following, Sir James Y. Simpson, of Edinburgh, introduced it in surgical operations. Of all these contributors to the greatest alleviation yet found for physical suffering, perhaps the most memorable was the unhappy dentist of Hartford.

WESTCOTT, BROOKE FOSS, English clergyman, was born near Birmingham, Jan. 12, 1825. He was educated at Trinity College, Cambridge, graduating in 1848, and being chosen fellow of his college. He was ordained priest in 1851 and became assistant master at Harrow School, holding the position seventeen years. He became canon residentiary of Peterborough in 1869, and regius professor of divinity at Cambridge in 1870. He was also rector of Somersham from 1870 till 1882, and held various positions of honor. In 1884 he was made canon of Westminster. He has given special attention to the history of the English Bible, and from 1870 to 1881 he was a member of the New Testament Revision Company. Among his publications are *History of the Canon of the New Testament* (1855); *Introduction to the Study of the Gospels* (1860); *The Bible in the Church* (1864); *The Gospel of the Resurrection* (1866); *History of the English Bible* (1868); *Revelation of the Risen Lord* (1882); *Revelation of the Father* (1884). He has published commentaries on the Gospel and Epistles of St. John, and has contributed to *Smith's Bible Dictionary* and *Dictionary of Christian Biography*. In company with Dr. Hart he edited the *New Testament in the Original Greek* (2 vols., 1881). Their labors were in great measure the basis of the revision of the English version.

WEST POINT. See **MILITARY ACADEMIES**.

WHEAT. See **AGRICULTURE**, Chap. V. 1.

WHEDON, DANIEL DENISON (1808-1885), theologian, was born at Onondaga, N. Y., March 20, 1808. He graduated at Hamilton College in 1828, studied law at Rochester, and was engaged in teaching. In 1833 he was made professor of ancient languages in Wesleyan University, Middletown, Conn. In 1843 he engaged in pastoral work, but in 1845 he was made professor of rhetoric and history in the University of Michigan. After ten years of service he returned to the pastorate at Jamaica, L. I., but in 1856 he was elected by the M. E. General Conference to be editor of the *Methodist Quarterly Review*. This position he retained by successive re-elections until 1884, when failing strength compelled him to abstain from work. He died at Atlantic Highlands, N. J., June 8, 1885. Besides his editorial work he published many addresses and sermons and contributed to various periodicals. His chief works were *The Freedom of the Will, as the Basis of Human Responsibility* (1864); *Commentary on the New Testament* (5 vols., 1860-75) and *Commentary on the Old Testament* (7 vols., 1880-86), the latter being left incomplete. Dr. Whedon was the ablest exponent of Arminian theology in the United States.

WHEELER, WILLIAM ALMON (1819-1887), nineteenth Vice-President of the United States, was born at Malone, N. Y., June 30, 1819. Early left an orphan, he taught school, spent two years at the University of Vermont, studied and practised law. He became superintendent of schools, district attorney of Franklin co., and Whig member of the Legislature in 1850. For fourteen years he was cashier of the Malone Bank, and for eleven president of the Ogdensburg

and Rouse's Point Railroad. In 1858-59 he was in the State Senate, and in Congress 1861-63 and 1869-77. His most conspicuous service was in adjusting political complications in Louisiana by the "Wheeler compromise" in 1874. In 1867 he was president of the State constitutional convention, in 1873 a commissioner of the State parks, and in 1876 of the State survey. In the latter year he was a candidate for the Republican nomination for President, but accepted the second place on the ticket with R. B. Hayes, and occupied the Vice-President's chair till 1881. Then he retired to Malone, and died there June 4, 1887.

WHEELOCK, ELEAZAR. See **DARTMOUTH COLLEGE**.

WHIG PARTY. This American political organization was the leading rival of the Democratic party (*q. v.*) during the second quarter of this century. In a measure it was the successor of the old Federalist party, which had been first defeated at the election of Jefferson to the Presidency, and finally destroyed by the victorious close of the war of 1812, which it had opposed. After the war, economic questions came to the front. The war had united the people of the seaboard and of the interior more closely in spirit; but the great natural barriers still obstructed their intercourse. The former Republican party, as directed by Jefferson, wished to refer all questions of internal interest to local legislation, as more directly representing the people affected by them. But the vast extent of roads and canals required to overcome the natural obstacles required larger plans and more liberal aid than the States severally could furnish. Popular leaders who saw the necessity called upon the national government to exert its power for the general welfare. Jefferson himself had waived his theory of government in his purchase of Louisiana; and his successor, Madison, had done the same in chartering the U. S. Bank. National aid to internal improvements had also received favor during the administration of these Presidents. Monroe's administration also wavered in regard to the theory of the strictly limited power of the Federal Government, and in that of John Quincy Adams the liberal view prevailed. This was seen not only in the promotion of internal improvements, but especially in the passage of the protective tariff of 1828. Henry Clay was the leading exponent of this view, but was still classed as a Republican, until the partisans of his jealous rival, Andrew Jackson, succeeded in thrusting him from its councils on account of his aiding the accession of Adams and then entering the cabinet as secretary of state. In succeeding contests, Jackson, who had roused the mass of the people to a sense of their political power, carried with him the great bulk of the Republican party, which now assumed the appropriate title, Democratic.

Clay's adherents, when forming a separate organization, called themselves at first "National Republicans," but soon adopted the briefer title, "Whigs." This name had been used first in Great Britain at the close of the seventeenth century to denote those who favored the authority of Parliament and advocated constitutional limitations of the royal power. Before the American Revolution it had been transferred to this country to indicate in like manner those supporting the rights of the colonies against the encroachments of King and Parliament; and it was, therefore, still highly popular. The Whigs not only favored the tariff of 1828 but also the U. S. Bank and certain internal improvements, which they declared were necessary.

The Whigs held their first national convention in Baltimore in 1831, and nominated Henry Clay for President. But Jackson won the day, with 219 electoral votes against 49 for Clay. In 1832 Clay, in view of the troubles with South Carolina, proposed a compromise granting a reduction of the tariff; but making the change gradual, that the manufacturers might adapt themselves to it. To that end it was pro-

posed to aim at reducing all duties above 20 per cent. ad valorem, to that figure as a uniform rate, but to provide that only one-tenth of the excess should be deducted annually—thus making the last reduction take effect in 1842. Although this measure passed both Houses, yet it was not favored, either by Jackson or Webster.

The steadily increasing pressure of the slavery question tended to divide and demoralize the Whig party. When the House of Representatives in 1838 passed the Twenty-first rule, which declared that every petition, etc., relating to slavery or the abolition thereof should be laid upon the table without being debated, printed, or referred, the Northern Whigs voted against this rule, which became known as the "Atherton Gag;" but the Southern Whigs joined with Northern and Southern Democrats to sustain it. The Whigs were apparently in favor of allowing the Abolitionists the right of petition, yet they were ready to fight them if they used it. They were jealous of the increasing power of the Abolitionists, nearly every vote of whose strength they saw would be taken from their own party. The Whigs were again defeated at the Presidential election of 1836 when William H. Harrison was their candidate. Van Buren had 170 electoral votes, and 114 were distributed among four Whig candidates—Harrison having 73. While the victory of Van Buren was pronounced, he was considered the political legatee of Jackson, and, therefore, all the bitter conflicts of the preceding administration were continued in that of Van Buren. The commercial crisis of 1837, which was undoubtedly due to Jackson's policy, gave an opportunity to the Whigs which was improved to the utmost. The nomination for the Presidency in 1840 should have been given by the Whigs to either Daniel Webster or Henry Clay, had it been decided by the real value of their services, but the working politicians considered that Gen. William H. Harrison was more "available," and he was nominated. The ensuing campaign was probably the most stirring and personal that has ever been waged in the United States. Harrison received 234 electoral votes; and Van Buren, who had been renominated unanimously in his party's convention, had but 60. Tyler, succeeding to the Presidency after Harrison's death, soon proved himself not to be in sympathy with the Whigs, and those of them who had been chosen by Harrison to form his cabinet resigned shortly afterward. Daniel Webster, however, remained secretary of state for some months, in order to complete the negotiations with Great Britain about the boundary line between Maine and Canada.

Meantime the Whigs, under the leadership of Clay in the Senate, succeeded, before a really open rupture with the President came, in repealing the Sub-treasury Act; in enacting a national bankrupt law; distributing prospectively among the States the proceeds of the public lands; and also in enacting the tariff of 1842. The movement to annex the republic of Texas was favored throughout the South, but was opposed by the Whigs in the Northern States. Clay favored the annexation of Texas as soon as that republic ceased its war with Mexico; but the more aggressive policy of the Democrats for such annexation and for the occupation of the Territory of Oregon to the limit of 54° 40' N. gave them a stronger hold upon the popular vote. Clay, in accepting the nomination for President in 1844, expected Van Buren to be his rival, and that the issues would be simply those of internal improvements, the national bank, and a protective tariff. Had the campaign been fought upon these issues it is likely that he would have been elected. As it was, he received only 105 votes as against 170 for Polk, another "available" candidate. To gain support in the South, Clay had written a letter on the annexation of Texas, declaring that he would be glad to see it annexed "without dissension, without war, with the common consent of the nation,

and upon just and fair terms." The effect of this letter was greater in the North than in the South; it carried many Northern Whigs over to the Free Soil party. This defection, more than any other cause, gave the State of New York to Polk by only 5106 votes. The Democrats, being thus thoroughly entrenched in power, repealed the tariff of 1842 and enacted in 1846 a tariff for revenue only. The election of Polk was also interpreted to mean the national approval of the annexation of Texas, and that step involved a war with Mexico. The Northern Whigs then began to recruit the ranks of the Free Soil party. The Whigs of the South, along with Clay, regarded slavery as a legitimate institution not to be hastily interfered with. Both of the parties in the North were also divided upon the question; each had its faction in favor of slavery and another against it. Thus the Mexican war opened with the two political parties divided almost upon Mason and Dixon's line, for the annexation of Texas was an extension of the domain of slavery, and the Mexican war opened up a long vista of such extensions. Then followed a curious phase of political history. Although the war commenced by a Democratic administration was successful from the outset, yet the House of Representatives elected in 1846 had a large Whig majority. The defeat of the Democrats was owing to the tariff of 1846, the failure of the administration to sustain the advanced boundary of Oregon, and, more than all, because the war had been undertaken for the sake of extending the area of the slave States. The Whigs, having control of the popular branch of Congress, attempted to pass the famous Wilmot proviso that slavery should not exist in any territory acquired from Mexico. The administration was strong enough to defeat the proviso; but it was not strong enough to bear down the returning tide of Whig power. The glory which was acquired by Gen. Taylor led to his nomination for President by the Whigs in 1848. Once more Clay and Webster were rejected as the standard-bearers of their party. The managers of the Whigs planned and executed a campaign which avoided the issue upon the slavery question. Their non-committal course alienated some of their party in New England who refused to support Taylor and became known as "conscience Whigs." William H. Seward prevented a similar defection among the Whigs of the State of New York, and Pres. Polk had alienated many Democrats in that State by failing to recognize Van Buren and Silas Wright, whom he distrusted as rivals. The vote of New York went to Taylor and elected him President. His electoral votes were 163, as against 127 for Cass, the Democratic candidate, and none for Van Buren, now the Free Soil candidate. The latter days of that campaign will be ever memorable in the annals of American political history for the combined efforts of William H. Seward, Thurlow Weed, and Horace Greeley to carry the State of New York. Pres. Taylor formed his cabinet in accordance with the non-committal lines upon which the campaign had been fought. The members were drawn in about equal numbers from the North and the South, but the more influential of them were from the North. The re-entry of Calhoun into the Senate and the prodigious efforts of Clay and Webster in that body showed that slavery was still the burning question. It was now 43 years since Clay had first appeared in the Senate, and he was still in full vigor. His resolutions, which were afterward put in the shape of a general measure known as the "Omnibus bill," were to the effect that Congress should not restrict slavery in the Territories; that California should be admitted without restrictions; that Congress had no power to obstruct the slave-trade between the slave States; and that a more effective fugitive slave law should be enacted. The Omnibus bill, though granting largely the demands of the South, was opposed by Pres. Taylor. Had he lived to finish his term it is probable

that the Compromise measures would have been defeated because, as a Southern man, he was enabled to take ground which a President from the North could never have suggested or held. Millard Fillmore, of New York, succeeded to the Presidency, and it was well known that he did not sympathize with Taylor's attitude. He openly used his influence in favor of the Clay Compromise. The Southern Whigs, under the lead of Clay, favored the compromise, but there was earnest opposition from Northern Whigs, who followed William H. Seward. The President approved separately all the bills which had formed the compromise. These were the Fugitive Slave law, the admission of California, the organization of New Mexico and Utah without restrictions as to slavery, and the prohibition of the slave-trade in the District of Columbia. The wedge which had been inserted into the Whig party upon the question of slavery was gradually driven home. In 1852 the Whig Convention met in Baltimore. The Southern members of the party were in favor of Fillmore. Webster was a candidate; but in spite of his famous speech of March 7, 1850, in advocacy of the compromise, he obtained little support among the Southerners. Gen. Winfield Scott was supported by the anti-slavery Whigs, for although he was a Virginian, he had an established military reputation. The votes were strictly upon geographical lines. Fillmore having almost every Southern vote and Scott every Northern vote, except 16 for Fillmore and 29 for Webster. Clay, from his death-bed in Washington, asked his friends to support Fillmore. After a long contest some of the Fillmore delegates went over to Scott and nominated him. The platform, however, was designed to conciliate Southern voters; it accepted the Fugitive Slave law and other kindred enactments as a finality on the questions of the day. In the earlier part of the campaign the Whigs had apparently a very fair show of success; there was much enthusiasm over Scott on account of his war record. But the rival factions of the Democrats in the State of New York came together. Van Buren returned to them and their prospects brightened. The Whigs found that although their platform was acceptable to the Southerners, yet their candidate was not acceptable because of his support by such anti-slavery men at the North as Seward and Greeley. Thus the Whig party lost day by day, and finally Pierce received 254 electoral votes and Scott but 42. This was the last contest in which the Whigs took an active part. All subsequent efforts for the revival of the party were without avail because of the ever-increasing importance of the discussion upon slavery bore down everything before it. The newly-formed Republican party, organized in opposition to the extension of slavery, soon absorbed the anti-slavery Whigs, while the pro-slavery Whigs, after some dallying with the Native American party (*q. v.*) and a futile attempt to organize a Constitutional Union party, found a more congenial home among the Democrats.

Hildreth's *History of the United States* presents a fair view of the Whig party. See also the *Speeches of Clay and Webster*, and Carl Schurz's *Henry Clay* (1887). See in this work REPUBLICAN PARTY.

(F. G. M.)

WHIPPLE, EDWIN PERCY (1819-1886), essayist and critic, was born at Gloucester, Mass., March 8, 1819. Soon taken by his widowed mother to Salem, he attended the public schools. His education, except as it was conducted by himself, ended at 15, when he became a bank clerk; but he had written for the press a year before this. In 1837 he was transferred to a bank in Boston, and thence to the Merchants' Exchange, as secretary and superintendent of the reading-room. This position, while securing him from want, gave him leisure to follow his bent, which was strongly literary, though his training had been much more financial and practical than scholastic. In 1840 he read a poem with eminent success before the Mer-

cantile Association, but all his later work was done in prose. His essay on Macaulay, printed in 1843, won acknowledgment from that author, who became one of Whipple's chief models in style. He soon became a contributor to the *North American Review* and other periodicals, wherein his writings attracted much attention, and were supposed to mark a point midway between the old manner and the new, as typified at the two extremes by Channing and Emerson. Another audience was brought within his reach by the lecture-platform, on which he is said to have appeared a thousand times, though rarely or never going farther than the Middle States. He was never an agitator—a pleader; but many welcomed his frank, dispassionate, and kindly discussion of men and things, and chiefly of ideas and books. His abundant material, always carefully prepared with reference to the requirements of the lyceum or magazine, was but sparingly gathered into volumes. *Essays and Reviews* appeared in 2 vols., 1848, and *Lectures on Subjects Connected with Literature and Life* the next year. A judicious distrust of the patience of audiences appeared in his terse, pithy sentences, neither overloaded with ornament nor burdened with unduly profound thought, but full of sensible observations, fitted to make the every-day reader somewhat wiser. These early books of his were fully up to the requirements of their time, and met unfriendly handling only from Poe, who found the author too genial. Of Poe's acerbity Whipple was incapable; his happy, even, amiable, and manly spirit made no enemies, and had nothing in common with the supposed malignity of critics. He and R. G. White, long the only Americans of established repute in this profession, always wrote of each other in kindly terms; their spheres were so different that they never clashed. In 1850 Whipple was the Boston orator; his subject, suited to July 4th, was *Washington and the Principles of the American Revolution*. In 1860 he resigned his post at the Merchants' Exchange, and gave himself up to a purely literary life, for lecturing with him was merely a convenient method of expression. He was no eager bookmaker, for 17 years elapsed before the appearance of *Character and Characteristic Men* (1866). His lectures at the Lowell Institute, published in 1869 as *Literature of the Age of Elizabeth*, won high praise. *Success and its Conditions* followed in 1871; his *Essays* were collected in six volumes the same year. After his death at Boston, June 6, 1886, two later books were published, with introductions by Whittier and Dr. Bartol, *American Literature and Other Papers and Recollections of Eminent Men*, both in 1887. Whipple was not a man of originality and genius, but he had the respect and fellowship of those who were. He was a figure in the literary life of Boston at its best, and filled a place of his own—the self-taught man who prefers truth by the way of literature to worldly affairs, and reads and thinks that he may write, caring chiefly to sift intellectual and moral values, and get facts and ideas into their true light and relations. The choice was worthy, and nothing in his career belied it. His fame and works are unlikely to live forever, but he was for years a civilizing influence, and to some the best teacher of the matters he took in hand.

(F. M. B.)

WHIPPOORWILL, the common name of the *Antrostomus vociferus*, one of the most common and interesting of the North American birds, of the goat-sucker or night-jar family. To an untrained observer this bird bears a great resemblance to the common night-hawk (*Chordeiles or Chordeiles popetue*), but its voice and its more strictly nocturnal habits separate the species very clearly; and, on close observation, quite a number of small but important physical marks of distinction are perceptible. Its generic name, *Antrostomus*, or cave-mouth, is an appropriate one; but the latest systematists limit its application by reserving it for the chuck-will's-widow (*A. coroli-*

nenis), and by putting its near relative, the whippoorwill, back into the old European genus *Caprimulgus*, or with the goat-suckers proper. The name "Poorwill" is given to several Western North American species of *Nyctidromus* and *Phalacroptilus*. The whippoorwill takes its name from its loud and plaintive nocturnal cry. Country people consider it a bird of ill omen, portending death, and especially the death of young children. Its noiseless flight, strictly nocturnal habits, and its loud cry are doubtless the causes of the dread with which the ignorant rustics regard it. The mother-bird lays her eggs generally on a stump or on the bare ground, and makes little or no nest. The bird is not often seen near by. Occasionally the bird may be seen carrying one of its own eggs or one of its unfledged young in its huge mouth. The novelist Cooper calls this bird by the name "Wish-ton-wish," which is not an unapt imitation of its call; but that name properly belongs to the prairie-dog, being its name in the language of the Osage Indians.

(C. W. A.)

WHISTLER, JAMES ABBOTT McNEILL, artist, was born at Lowell, Mass., in 1834, and educated at West Point. For two years he was a pupil of Charles Gabriel Gleyre in Paris, and in 1863 settled in London. His peculiar and original theories on art have been the subject of much criticism, but he is an artist of strong originality and undoubtedly great talent. In some of his paintings he has succeeded in producing extraordinary and striking effects with but few and quite subdued colors. Among his more important works are *White Girl*, *Gold Girl*, *Blue Girl*, portraits of his mother and Thomas Carlyle, *Princesse des Pays de la Porcelaine*, and *At the Piano*. To many of his later paintings he has given names defining more closely his color-experiments, such as *Nocturnes in Blue and Silver*, *Blue and Gold*, *Blue and Green*, etc.; *Harmonies in Brown and Black*, *in Gray and Green*; *Arrangements in Black*, *in Gray and Green*, *in Gray and Black*, etc. He holds high rank as an etcher, and has executed series of plates on several European cities.

(F. L. W.)

WHITE, ANDREW DICKSON, educator, was born in Cortlandt co., N. Y., Nov. 7, 1832, and in childhood was taken to Syracuse, N. Y. He graduated at Yale College in 1853, having been while an undergraduate an editor of *Yale Literary Magazine*. He then went to Europe and for a time was an attaché of the U. S. Legation at St. Petersburg. He also studied at the University of Berlin and a year after his return to America in 1856 became professor of history and English literature in the University of Michigan. He resigned in 1862 and in 1863 he was elected to the State Senate of New York where he at once took a prominent part in legislation relating to education. He introduced bills codifying the school laws and making a new system of normal schools, and especially aided Ezra Cornell in organizing the Cornell University (*q. v.*). He was then induced to accept the presidency of this institution in 1867, and visited Europe to obtain for it the necessary apparatus. In 1871 he was one of the commissioners sent by Pres. Grant to Santo Domingo and assisted in preparing the report. In the same year he presided over the Republican State Convention of New York. In 1879 he was sent as U. S. minister to Germany, and on his return in 1881 resumed his duties as president of Cornell University. President White has published *Lectures on Mediæval and Modern History* (1861), several pamphlets and lectures relating to Cornell University, including one on the *Co-Education of the Sexes* (1871); *Warfare of Science* (1876); *The New Germany* (1882).

WHITE, RICHARD GRANT (1822-85), critic, philologist, and Shakespearean scholar, was descended from one of the first settlers of Cambridge, Mass., and was born in New York city, May 23, 1822. After graduating at the University of New York, 1839, he studied medicine and law, and was admitted to the bar in 1845, but

did very little practice. Either professionally or personally he was interested in the case of Bishop B. T. Onderdonk, and published an *Appeal from the Sentence* (1845); after the ecclesiastical trial. His newspaper career began the same year as editor of the short-lived *Alleghanian* and contributor to the *Courier and Enquirer*, of which he was associate editor 1851-58. He had been connected with *Yankee Doodle* in 1846, and later wrote for the *World*. His great versatility was early and eminently shown in his writings on music and art—topics which he never entirely abandoned, and on which he was an authority. In 1853 appeared his first volumes, one of them a *Handbook of Christian Art*, and his first magazine article on Beethoven. The civil war turned his literary activity into a new channel; *National Hymns* (1861), was followed anonymously by *The New Gospel of Peace*, in four parts, a pungent and effective satire on Northern sympathizers with the South. A series of letters to the *London Spectator*, from 1863 to 1867, showed no less strong loyal feeling. He edited *Burton's Book Hunter* (1863), the *Record of the New York Exhibition*, and *Poetry of the Civil War* (1866). He was for thirty years a constant contributor to *Putnam's Magazine*, *The Galaxy*, and *The Atlantic*. In the first of these he began to write upon his favorite subject, Shakespeare, or rather the plays, for of their author he professed the lowest opinion ever put forth. *Shakspeare's Scholar* appeared 1853. A variorum edition of the plays in 12 vols. (1857-65) included a memoir and essay separately published in 1865. In the same category belong his *Authorship of the Three Parts of Henry VI.* (1859), and in his last days *Studies of Shakspeare* (1886), previously printed in the *Atlantic* under the more vigorous title of *The Anatomizing of William Shakspeare*. These essays are models of vigor and suggestiveness, though their extreme position repels the sympathy of most readers. White pushes the "no nonsense theory" to all lengths, and berates numerically the German and other philosophizers, who insist on judging the man by his writings, and finding a human being with a great soul behind so much immortal poetry. His own view, however it may seem to fit with some of the facts, ignores others, and is less probable as well as less creditable to human nature. According to White, the man and his genius were apart and out of harmony; the man used his genius blindly and basely, caring nothing for what he wrote, reckless of fame and literary values, aiming only to fill his theatre and grow rich. Barely stated, this theory defeats itself and leaves the *Sonnets* unaccounted for; but White urged it with great boldness, tenacity, force, and plausibility, and his essays as well as his editorial labors on the text have an important place in Shakespearean literature. The same dogmatic and pugnacious positiveness, with the same industry, ability, and wide reading, appear in his philological books, *Words and their Uses* (1870; 3d ed., revised, 1880) and *Every Day English* (1879). In a field where every point is hotly and rancorously contested, White is thoroughly at home; had he lived a few centuries earlier he would have been equally zealous as a theologian. In his later years he was much abroad. His *England Without and Within* (1881), like most of his books, was a reprint of magazine articles; E. P. Whipple considered it the best account of the mother country since those of Emerson and Hawthorne. He attempted the international novel with less success in *Adventures of Sir Lyon Bruce in America* (1867) and *The Fate of Mansfield Humphrey* (1884). Mr. White is entitled to a high place in American literature; but his great ability and extensive product have not met adequate popular appreciation, though his record as a magazinist has scarcely been excelled. He had the virtues and some of the vices of a special pleader: he has been accused of hard egotism, narrowness, unfairness to opponents; but he was patient in investigation, honest in his

opinions, and fearless in stating them. His habits were studious and retiring rather than social. With all the enormous literary work that he accomplished, he held the chief clerkship in the revenue bureau of the New York Custom House from 1861 to 1878. He died in New York, April 8, 1885. (F. M. B.)

WHITE, WILLIAM (1748-1836), first bishop of the Protestant Episcopal Church in Pennsylvania, was born in Philadelphia, April 4, 1748 (March 24, O. S.). His father, Col. Thomas White, had emigrated from London 1720, settling in Maryland, whence he removed a year before the birth of his distinguished son. The boy's grave, devout, and blameless character seemed from earliest years to predict his future, and a friend declared that he was "born to be a bishop." From the age of seven he attended the College of Philadelphia, beginning with its English school, and graduated 1765. After a long course of theological study under the local clergy, Drs. Richard Peters and Jacob Duché, he went to England for orders in the fall of 1770 and passed his examination with great credit. He was ordained deacon in December, 1770, and priest in June, 1772. Soon after his return in September, 1772, he became assistant minister of Christ Church and St. Peter's (then and long after united), and married in February, 1773. His calm and gentle wisdom was exhibited on the outbreak of hostilities; he would not preach politics or make the church a recruiting station, but promptly took the oath of allegiance to the United States, retired to Maryland when the British approached the city, and on his appointment as one of the two chaplains of Congress at once proceeded to York and entered on the duties of this office, which he retained as long as Congress met in Philadelphia. On returning thither after the evacuation he was the only Episcopal clergyman in the State; but for his presence and example the prospects of his church would have been much darker even than they were. He became rector of the united parishes in April, 1779, stipulating for his resignation in case of the return of his predecessor, Dr. Duché (*q. v.*).

After the war had secured the independence of the United States, Dr. White did far more than any other to uplift the church from the confusion, depression, and unpopularity into which she had fallen. Without waiting for peace to be formally declared, he published in August, 1782, a weighty and memorable pamphlet, *The Case of the Episcopal Churches Considered*. Its proposals, that in the councils and government of the church all parishes should be equal and laymen admitted to a share with the clergy, were soon adopted; another suggestion, born of the crying needs of the times, that a superior order of clergy be temporarily provided to take as far as they could the duties of the episcopate till the succession could be procured, was presently invalidated by the conclusion of peace with England, which involved the possibility if not the near prospect of obtaining consecration there. Though few Episcopal ministers remained in America, White did not despair but opened a correspondence with them and with laymen of influence looking to measures of organization. He presided at meetings held in 1784 in his own city and at New Brunswick, N. J., and at the first General Convention in Philadelphia, September, 1785. Here he drafted an address to the English Bishops, which was sent through the U. S. minister, John Adams. At length Parliament authorized these prelates to consecrate Americans: conventions of the diocese of Pennsylvania had met in May, 1785, and June, 1786, and White was elected bishop Sept. 14, 1786. On Nov. 2 he sailed with Dr. S. Provoost, who had been likewise chosen in New York. They were consecrated in Lambeth Chapel, Feb. 4, 1787, and landed in New York two months later. Dr. Seabury had been consecrated in Scotland, 1784, as Bishop of Connecticut; he joined his brethren in the convention of 1789 at which the P. E. Church in America was duly organized, Bishop White drawing up its constitution, and with Bishop

Seabury taking the chief part in the revision of the Prayer-Book.

As in forming, so in guiding, Bishop White was the father of his church: his kindly serenity, his wise tolerance, his dislike of extremes, the lofty purity of his character, his lack of narrow and self-seeking views, adapted him to the part alike of leader and peacemaker; his was the directing mind which shaped the church's early course; he was to it "what Washington was to the country," and his writings were its *Federalist*. His *Lectures on the Catechism* appeared in 1813, his *Comparative View of the Controversy between Calvinists and Arminians* in 1817, his *Memoirs of the P. E. Church in the United States*, 1820 (enlarged 1836). The latter has been criticised only as minimizing, if not concealing, his own great services. For forty years he was senior and presiding bishop, active in and beyond his own diocese which under him grew to 86 ministers and 91 congregations. He consecrated 26 bishops. A society which he founded in 1816 was the beginning of Episcopal home missions in the West. A third parish, St. James, was organized in Philadelphia in 1809, and he was rector of the three till his death. With hardly any stipend as bishop, he travelled over the State till 1827, when an assistant was provided. Meticulously faithful to every duty, he never left his post, but ministered alike to the sufferers from yellow fever in 1793 and from cholera in 1832. From 1787 he occupied one house in Walnut street above Third. His views were moderately "Low Church," but he was the correspondent of Priestley, the friend of all good men and useful measures. He died July 17, 1836, universally honored and beloved. His *Memoir*, by Dr. Bird Wilson, appeared in 1836; his fittest epitaph is Wordsworth's line, "Saintly White, patriarch of a wide-spreading family." (F. M. B.)

WHITEFISH, the common name of all the species of the genus *Coregonus*, family *Salmonidae*, which are abundant in the Great Lakes and in all the British American Lakes perhaps as far north as the Arctic Ocean. In this section of the Salmon family the body is covered with scales of moderate size, the cleft of the mouth is small, the teeth, if present, are extremely minute and deciduous, the dorsal fin is of moderate length, the caudal deeply forked. The body is elongated but thick, the head small and pointed, the general appearance being like that of the shad. There are in all about two American species, all lacustrine in habitat, each species being localized, though in some cases three or more are found in the same lake. They vary in size from the large lake whitefish, averaging 3 to 5 pounds in weight, to the little "lake herring" of the Saranac Lakes. The whitefish are the most important food-fishes of the Great Lake region, and are of vital importance to some northern tribes of Indians. In quality of flesh they have no superior among our food-fishes, the flesh being white, tender, juicy, and of delicate flavor, and never producing a feeling of satiety like the salmon.

The most important species is *C. clupeiformis*, the large lake whitefish, which is found in all the Great Lakes, attaining its largest size in Lake Superior, where it averages over 5 pounds in weight, though a specimen has been taken of 23 pounds. In the other lakes it is smaller, the usual size brought to market being about 2 pounds. It is in color bluish-gray on the back, lighter on the sides, and white below. This species is supposed to feed on the small crustacea and other small animal forms of the lake waters. It comes in vast shoals into the shallow waters of the lakes to spawn and is then caught in large quantities in nets. Like the shad, it apparently eats nothing during the spawning season.

The species next in importance to the above is *C. artedii*, the "lake herring," of smaller size but one of the most abundant of the great lake fishes. It is a valuable food-fish though considerably inferior in quality to *C. clupeiformis*. In the lakes of the Rocky

Mountain region occurs *C. Williamsoni*, a fish of about a pound weight which ranks high as a food-fish. Another species, *C. Otsego*, known as the "Otsego bass," has as yet been found nowhere but in Otsego Lake. It is about half the weight of the lake whitefish and is said to surpass even this fine fish in excellence. The whitefish were among the first which were subjected to experiments in artificial reproduction. The efforts in this direction were very successful and there is good promise of keeping up a full supply in the lakes by this means.

Many other fish are known as whitefish in certain localities. This title has been given to the bluefish, the menhaden, the tile fish, and the silver salmon, and in Europe is applied to the numerous species of the genus *Leuciscus*, a genus which includes the roach, the chub, the dace, the smelt, the minnow, and other fish of well-known common names. (C. M.)

WHITEHOUSE, FREDERICK COPE, son of Bishop H. J. Whitehouse (1803-1874), of the Episcopal Diocese of Illinois, was graduated with honor from Columbia College in 1861. Possessed of abundant means, he has devoted his life to explorations in many fields of learning and has especially distinguished himself by his examination of Egyptian problems, chief of which is the siting of Lake Moeris. He has by personal and repeated visits and surveys assured himself of the identity of the Fayoum, including the deep depression of Raiyan, with the ancient lake and has suggested to the Egyptian government the expedient of again filling this region with the Nile through the Bahr Yusef and thus greatly enriching the land. His view sustains the truth of Herodotus, and, although many regard it as visionary, it has excited the interest of Egyptologists and the government of Egypt and has many supporters.

WHITE LEAD. In the latter part of the last century the first white lead manufactory was established in the city of Philadelphia, and the success of this establishment soon induced others to engage in the business of corrodng lead for the production of the pigment. The growth of this industry was rapid, and early in the present century corrodng works were established in the cities of Pittsburg and New York, in the former of which the manufacture of red lead was one of the principal articles produced. The quality of the pigment produced by these pioneers in the business was equal to the imported and the consumption of the home product increased rapidly. The process employed by these corrodngs was what is known as the old "Dutch process," and it was not until later years that new processes were employed, but the product of these have never met with popular favor, although the price of what was known as "new process" and "patent process" white lead was lower than the lead made by the older method. At the present time there are thirty-six corrodng works in the United States, located in the States of Pennsylvania, New York, Massachusetts, Maryland, Missouri, Kentucky, Ohio, Illinois, California, and Nebraska. Those located in the city of Brooklyn are the largest. Many of these have also added the manufacture of red lead and litharge, while several produce orange mineral superior to the imported.

The products of the corrodng works in this country are almost exclusively from the native mineral, and that from the Rocky Mountain district is ordinarily preferred. It is only during seasons of unusual high cost of the native mineral and depressed value of Spanish lead that the crude mineral from the latter country is imported for corrodng purposes. The annual consumption of white lead in the United States is about 65,000 tons and is growing rapidly, the average annual increase being about 10 per cent. The capacity of the several corrodng works is largely in excess of the production, and for this reason the competition between the corrodngs is keen and tends to keep the price of their product so low that the busi-

ness is not at all times profitable. Associations of manufacturers have at different periods been formed for the purpose of regulating the price, but they have been only temporarily successful. A "white lead trust" has recently been formed which embraces a majority of the corrodng works in the country. The product of the American works compares favorably with that of the foreign. In former years adulteration was almost universal; later the manufacturers produced several grades with varying proportions of barytes, but now nearly all the corrodngs sell the pure pigment only, leaving the adulteration to others. The reliability of the American brands has become so well known that white lead of foreign manufacture is being imported in yearly decreasing quantities. In 1871 the imports of white lead, mostly of English manufacture, reached a total of over 8,300,000 lbs., since which there has been a decline in the imports until for the past few years they have not averaged above 1,000,000 lbs.

The average price of white lead in 1850 was 7 cents per lb. During the late war, in common with all other manufactures, the price advanced rapidly, reaching the highest point in July, 1864, when 21 cents was paid in the New York market. In 1865 the highest price was 18 cents and the lowest price 13 cents per lb. Not until 1870 did the price go below 10 cents, and the average price remained under 10 cents only 3 years. In 1873 the average price was over 10 cents, as also during the succeeding 3 years. In 1879 the average price had dropped to 9½ cents per lb., since which year there have been only moderate fluctuations, with the average price gradually declining until 6 cents was reached, from which the variations have not been important, although the lowest price reached was 5½ cents in 1887.

Most of the red lead now manufactured in this country, owing to the exacting requirements of manufacturers of glass, is made from refined lead, the silver, copper, antimony, bismuth, arsenic, and other foreign metals being removed, so that the oxide produced is in a state of purity not equalled by the older processes. There is also considerable red lead of the very best quality made from the "scraps" produced in the process of corrodng white lead. These scraps are the hard lumps of the imperfectly corrodng white lead, and are simply oxidized in a reverberatory furnace. As the lead used in the manufacture of white lead must be quite pure, the red lead made from these imperfectly corrodng scraps is also very pure and particularly well adapted for glass-making. No estimate of the amount of red lead produced in the United States can be given, as the manufacturers decline to state their output. The imports during the year 1875 exceeded 1,000,000 lbs., but since then there has been a gradual decline, the amount of late years averaging about 250,000 lbs. The price varies with the price of pig lead, while competition has always prevented excessive fluctuations.

The manufacture of litharge in this country has almost entirely excluded that of foreign manufacture, the imports now averaging barely 50,000 lbs. annually, while in 1868 the amount imported was 250,000 lbs. This is due to the quality of the domestic product, it being in every respect equal to the best imported, whereas the latter is of higher cost to the consumer. In the manufacture of glass litharge is not used to the same extent as formerly, red lead taking its place, but for other uses the consumption has increased, and the consumption is of steady growth. The amount produced is not available, as the manufacturers decline to give the desired statistics, although stating "capacity" of their works. The price varies with the cost of pig lead. (H. G. A.)

WHITE PLAINS. See REVOLUTIONARY WAR.

WHITING, WILLIAM (1813-1873), lawyer, was born at Concord, Mass., March 3, 1813. His ancestor came to Boston in 1636, and was the first minister of

Lynn. After graduating at Harvard, 1833, he studied law, was admitted to the bar, 1838, and entered upon successful practice at Boston. His reputation as an authority on the peculiar legal questions arising from the outbreak of the rebellion and civil war attracted the attention of the government and caused his appointment as solicitor of the war department in 1862. Here he wielded great influence in a quiet way on the counsels and activities of Lincoln's administration. His publications were confined to pamphlets, but one of these attracted no little attention at home, and was extensively sold in Europe. *The War Powers of the President, and the Legislative Powers of Congress, in Relation to Treason, Rebellion, and Slavery* (1862) opened and fully occupied a new field. This treatise passed through twenty-seven editions within a few years. In Carpenter's painting of Lincoln and his Cabinet the President directed that this book should have a prominent place. To its original chapters were added in the later editions others on Military Arrests, Military Government, and Reconstruction. Whiting was for some time president of the New England Historical-Genecological Society, and in his last year was elected to Congress. He died in Boston, June 29, 1873.

WHITMAN, WALT, poet, was born May 31, 1819, at his parents' farm-house, West Hills, western Suffolk co., L. I.; of English stock from the father's side and of Holland Dutch from that of the mother, Louisa Van Velsor. The family moved to Brooklyn early, and in that place and New York city Whitman's boyhood and early manhood passed. He went to the public schools, and in due time learned the printer's trade and worked at it. He also lived in the country on Long Island, taught school, labored at farm toil and house-building, and published a weekly newspaper. New York and Brooklyn, however, were his principal head-quarters till he was nearly 30 years of age, when he started travelling, first to Louisiana, passing a year there, and then to leisurely visits and occupation, in nearly all the Southern and Western States, one after the other. Then, returning to Brooklyn, he put in shape and issued (1855) the first portion of *Leaves of Grass*, which has been fashioned and increased until now (1889) it is considered finished by the author's last pieces, *Sands at Seventy*, as annex to the previous ones.

During 1862 to 1865, inclusive, Whitman was arduously occupied in the area of the civil war in Maryland and Virginia and in and around Washington City, with the wounded and sick of the armies, both Northern and Southern, giving fully three years to those special ministrings. He had always possessed the best health and strength, but about the close of the contest he was prostrated by a severe stroke of paralysis. Though he surmounted it, a broken physique resulted, and some six attacks have at times followed from it since.

His literary works are comprehended under three titles, the *Leaves of Grass*, his main work and form of poetic expression, passing through five stages or increments, beginning in 1855 and completed in 1888; his prose book, *Specimen Days and Collect* (1883), forming biographical notes, personal memoranda during the civil war, with various essays, including "Democratic Vistas." He has never recovered from the physical paralysis of the war period and agitation of 1860 to 1865; but, his mental powers remaining unaffected, he has worked steadily at his literary plans, and during 1888, in his seventieth year, finished the booklet of *November Boughs*, his last work, containing both poems and prose.

The time has probably not yet come for pronouncing definitely on Walt Whitman's place in literature. His main characteristics may safely be said to be daring originality in thought as well as in form, contempt for conventionalities, marvellous fecundity and felicity of expression, and boundless admiration for democracy as developed in the America of to-day, or

rather, it may be, in that ideal America that looms up before his poetic eye. By not a few he is held to stand side by side with Emerson as one of America's truly representative geniuses. Others, startled by the outré appearance of his rhymeless verses, his defiance of conventionalities and his frequent mysticism, see little to admire in him. He is highly appreciated in England, and his pieces have been translated into several modern languages.

His tender care for the wounded and sick during our civil war have endeared him personally to every true American. Nothing can be more touchingly eloquent than some of his letters to his mother descriptive of the scenes he witnessed in the hospitals. He resides on Mickle street, Camden, in a plain frame dwelling which has become a shrine where he receives the homage of numerous devoted admirers, not a few from foreign lands. He is a bachelor, and his real amiability and charm of character endear him to all who know him.

WHITNEY, ELI (1765-1825), the inventor of the cotton-gin, was a farmer's son, born at Westborough, Worcester co., Mass., Dec. 8, 1765. His early advantages were limited, but his mechanical gifts were shown and utilized in childhood. At 16 he began to manufacture nails, and followed with pins and canes. Entering Yale College at 24, he worked his way through the course, and after graduating, in 1792, accepted a private tutorship in Georgia, but on arriving found the place given to another. The widow of Gen. Greene took pity on his necessitous condition, entertained him at her house near Savannah, and, finding him useful in making or mending any sort of implement, referred to him some neighbors who were troubled by the slow and laborious process of separating cotton from its seed. Whitney had then no acquaintance with the plant, but found specimens of its seed and went to work. Full of inward resources, though sadly lacking in external facilities, he made his own tools and wire, and had success in view when the eager impatience and selfish greed of unknown persons delayed the execution of his plans and opened the way to innumerable vexations and disappointments. His first machine, kept secret and under lock, was stolen when yet incomplete, copied, and put in operation before he was able to produce another and secure a patent. He would now have been helpless, but that Miller, tutor to Mrs. Greene's children and afterward her husband, entered into partnership with Whitney in May, 1793, and supplied funds till his death in 1803. Whitney went North to construct the gins and obtained a patent March 14, 1794, which was contested in Georgia. His history embraces all the proverbial trials of inventors, which he met with indomitable patience, resolution, and tenacity. One difficulty after another arose in his path. He could not manufacture enough machines to supply the demand of an increased crop of cotton, planted in reliance on the invention, and the stolen gins, however inferior to his, were eagerly purchased. Obligated to borrow money at high rates, the burning of his shop with all its contents made him a bankrupt. The gins were brought into discredit for a time by an unfounded idea in England that they weakened the cotton in cleaning it. When this prejudice subsided, the market was stocked with pirated machines, which became yet more abundant when the first suit brought for violation of patent was decided against the inventor. Worn out with the injustice of Georgia, he sought relief in other States. The Legislature of South Carolina in 1801 voted him \$50,000 for the State right to his gin, but many delays, annoyances, insults, and expenses ensued before the sum was paid. In Tennessee he received fair promises, which were soon disowned. In North Carolina alone was he fairly treated; a tax imposed in 1802 for five years on every saw employed in ginning supplied him with means to prosecute his suits in Georgia. There in 1807 he obtained a tardy injunction on infringe-

ments of his patent. Under the urgency of the Southern members, Congress in 1812 declined to renew this patent; though its inventor had doubled the wealth of the cotton States by developing their chief industry, he was not entitled to a continued reward. His chief means were drawn, not from the cotton-gin, but from the manufacture of implements of destruction. Seeing the need of another resource, he had begun to make arms in 1798, and obtained a large contract from Oliver Wolcott, secretary of the treasury. Obligated to do everything from the first steps on, he was unable to furnish 10,000 muskets in 2 years, as he had agreed; but the time was extended to 10 years and the funds advanced as he needed them. The treatment he received from government in this case was in happy contrast to the ingratitude and injustice which repaid his far more useful and important services. By degrees he built up a great arsenal at Whitneyville, Conn., filled large orders for the United States and New York, introduced improvements in firearms and other iron commodities, and realized a fortune. Yet it was the cotton-gin alone which, in Fulton's opinion, placed him with Watt and Arkwright among the greatest recent benefactors of mankind. He married a descendant of Jonathan Edwards in 1817, and his later years were passed in peace and comfort. He died at New Haven, June 8, 1825. (F. M. B.)

WHITNEY, JOSIAH DWIGHT, geologist, was born at Northampton, Mass., Nov. 23, 1819. He graduated at Yale College in 1839, and spent five years in scientific studies in Europe. He has been engaged on the geological surveys of Ohio, Mississippi, Michigan, and California, beside the U. S. government surveys of the Territories. In 1865 he was made professor of geology in Harvard University. He is a member of the American Association for the Advancement of Science and of other scientific bodies. His publications include *The Metallic Wealth of the United States* (1854), and *Reports on the Lake Superior region, the upper Mississippi lead region, and the Geological Survey of California* (1864-70). He contributed to the *ENCYCLOPEDIA BRITANNICA* that part of the article UNITED STATES which relates to physical geography.

His brother, WILLIAM DWIGHT WHITNEY, philologist, was born at Northampton, Mass., Feb. 9, 1827, and graduated at Williams College in 1845. After three years spent as a bank-clerk, he began the study of Sanskrit at New Haven, 1850, and went abroad the next year to pursue it more fully. For three years he labored at Berlin and Tübingen, and planned with Prof. Roth an edition of the *Atharva-Veda-Samhitā*, which appeared in 1856. For this he made copies and collations of all the MSS. in Europe. In 1854 he was appointed to the chair of Sanskrit in Yale College, founded for him by Prof. E. E. Salisbury (q. v.); to this was added comparative philology in 1870. Besides these he has long held an instructorship in modern languages. He joined the American Oriental Society 1849, was its librarian 1855-73, and its corresponding secretary from 1857, spending much time in its service, and contributing largely to its *Journal*, of which he was long the chief editor; the greater part of vols. v.-ix. is from his pen. His edition of the translation by E. Burgess and others of the *Sūrya-Siddhānta*, or text-book of Hindu astronomy, appeared at New Haven 1860. Two years later he published the *Atharva-Veda-Prātiçākhyā*, text, translation, and notes, and in 1871 another Hindu grammatical book, *Taittirīya-Prātiçākhyā*, which received a prize from the Royal Academy of Berlin. His lectures on *Language and the Study of Language*, delivered at the Smithsonian Institution 1864, and later at the Lowell Institute in Boston, appeared in 1867, and a German translation by Dr. J. Jolly, 1874. His labors have not been confined to Sanskrit; his *German Grammar* (1869) and *German Reader* (1873) have been much praised and used, and he has prepared similar works in French and English. His

Oriental and Linguistic Studies appeared 1872, and a second series 1874. His *Life and Growth of Languages* (1875) formed part of the "International Scientific Series," and was translated into French and German 1876. His *Sanskrit Grammar* was published at Leipsic, 1879. He aided in the preparation of the *Sanskrit Lexicon* at St. Petersburg (1872-5), and has written for several German publications, and at home for Appleton's *Cyclopædia*, the *Bibliotheca Sacra*, the *New Englander*, etc. He was the first president of the American Philological Association. He is chief editor of the *Century Dictionary of the English Language* (1889). He has a European no less than a national fame, and is considered by many the foremost expositor of the science of language.

WHITTIER, JOHN GREENLEAF, one of the most popular and representative of American poets, was born at Haverhill, Mass., Dec. 17, 1807, in the farmhouse built by his ancestor, Thomas Whittier (1620-96), who came from Southampton, England, to Boston in 1638, and settled at Salisbury on the Merrimac and 10 years later at Haverhill. The family, for a generation or more before the poet's time, were Quakers, and to that connection he has adhered. On his mother's side he had in Stephen Bachiler, first minister of Hampton, N. H., a common ancestor with Daniel Webster. His early life on the farm, and the various members of the family, are described in his poem *Snow-Bound*, and other of his writings record his childish experiences. He was fond of reading, and began to rhyme at fourteen, stimulated by the loan of a volume of Burns. His first printed verses appeared in a local paper in 1826, and W. L. Garrison, then editing the Newburyport *Free Press*, called at the farm-house, encouraged and praised the young poet, and urged him to seek further educational advantages than the district school had afforded. By making shoes during the winter he earned enough to cover his expenses for six months at the Haverhill Academy, which he entered in April, 1827. In the winter following he taught school at West Amesbury, now Merrimac. He began to write verses for the *Haverhill Gazette* 1828, and continued these contributions nearly forty years. In the fall of 1828 Garrison, then in Boston, found him a place as writer on the *American Manufacturer*. This sheet he practically edited for some months, receiving \$9 a week, and meanwhile he wrote some verse for John Neal's *Yankee*. From June, 1829, to July, 1830, he was at home, working on the farm, the latter months editing the *Gazette*, and writing for the Hartford *New England Weekly Review*. He assumed the editorial chair of this paper in July, 1830, succeeding G. D. Prentice, and retained it eighteen months; during that time, besides many prose sketches and tales from his pen, it contained 42 poems of his, among them *The Vaudois Teacher*, which in a French version was greatly valued in the lower Alps, long before its authorship was known. His first volume, *New England Legends in Prose and Verse*, appeared at Hartford in February, 1831. Most of these early efforts were lightly regarded and suppressed by their author in after years, but they gave him a certain repute at the time. Before leaving Hartford he edited Brainard's *Poems*, and prefixed a sketch of that writer's life; the book was published early in 1832. That year Mr. Whittier was at home writing for Buckingham's *New England Magazine*, in which appeared *Mogg Megone* (in a volume, 1836). *Moll Pitcher* was published at Boston 1832. Garrison's *Liberator*, begun 1831, much influenced Whittier, who printed at his own expense a well-reasoned pamphlet of 23 pages, *Justice and Expediency, or Slavery Considered with a View to its Rightful and Effectual Remedy, Abolition* (Haverhill, 1833). Of this Arthur Tappan (q. v.), of New York, soon had 10,000 copies struck off for gratuitous distribution. This was the beginning of the poet's long and active share in the anti-slavery agitation. He handled the same topic in

five pages of the *Providence Journal*, July, 1833, and again in the *Essex Transcript*. He was a delegate to the National Anti-slavery Convention at Philadelphia, Dec. 4-6, 1833, and as one of the secretaries signed its *Declaration of Sentiments*. An anti-slavery society was formed at Haverhill, April 3, 1834, of which he was an officer and doubtless a leading spirit. The unpopularity of the cause did not prevent his being sent to the Legislature in 1835. The same year he had several experiences with mobs. He concealed George Thompson for two weeks, and soon after, with that English leader, narrowly escaped ill treatment at Concord. Meantime he continued to write prose and verse, largely on this subject. His spirited attacks on the clergy of Southern opinions and sympathies, as a *Pastoral Letter* (in the *Liberator*, October, 1837), called forth by a Congregational council at Brookfield, which tried to silence the Grimké sisters, *Clerical Oppressors*, etc., won the honor of liberal denunciation. His *Poems chiefly relating to Slavery* were published by Isaac Knapp, of the *Liberator*, Boston, 1838. The poets were generally for freedom, but S. J. May with abundant truth called Whittier "our laureate," and testified that "from 1832 to 1865 his harp of liberty was never hung up." The effect of these fiery strains in moulding the slow-growing popular sentiment which at last swept the land was inestimable. From his father's death in 1832 to 1837 the poet managed the farm, just making ends meet for the family. From May to December, 1836, he again edited the *Haverhill Gazette*. In the summer of 1837 he spent three months in New York as a secretary of the National Anti-slavery Society. At the end of that year he went to Philadelphia to write for the *Pennsylvania Freeman*, and was its editor from March 15, 1838, to Feb. 20, 1840. Nearly a third of this time he was at home in Massachusetts, or travelling for the society in Western Pennsylvania. His *Ballads* (180 pp.) were published in Philadelphia by the society, November, 1838. In May, 1838, the office of his paper was in the new Pennsylvania Hall, which was promptly sacked and burned by a mob. In May, 1840, he left Philadelphia for Amesbury, Mass., whither his family had removed (partly to be nearer their meeting-house) after selling the farm. Here he lived by his pen, and continued his anti-slavery labors, travelling much with H. B. Stanton in the interest of the cause; Wendell Phillips called him "a superb hand" at lobbying. *Lays of my Home*, etc., appeared in 1843. In 1844 he spent six months at Lowell, Mass., writing for the *Middlesex Standard*; some of these articles were reprinted in Boston as *The Stranger in Lowell* (1845). The Mexican war called out his active opposition. *Voices of Freedom* appeared at Philadelphia in 1849, and added much to his reputation. From 1837 to 1846 he wrote much for the *Democratic Review*; in this some of his best poems appeared, as *The Bridal of Pennacook* (1844-5). *The Supernaturalism of New England* was published in New York and London in 1847. The *National Era* was established at Washington in January, 1847, and Whittier was its assistant and corresponding editor till September, 1859. During these years he contributed to its columns more than eighty poems and a great quantity of prose, including *Old Portraits and Modern Sketches* (collected, 1850), *Literary Recreations* (1854), and *Margaret Smith's Journal*, 1678-99, a historical novel reprinted in Boston in 1849, and called by Miss Mitford a clever mystification. An illustrated collection of his poems in octavo was brought out 1849 by B. B. Mussey & Co.; the plates were afterward bought by his later publishers, Ticknor and Fields. *Songs of Labor* (1850) were gathered from the *Review* and *Era*. A selection from his poems was published in London, 1852, by Routledge. *The Chapel of the Hermits* and *A Sabbath Scene* appeared in 1853. *The Panorama*, etc., 1856, and a complete edition of his poems to date, 1857. Of his more notable short

pieces, *Ichabod* (on Webster) was first printed in the *Era*, May 2, 1850, to C. S. (Sumner) and *Maud Muller* in December, 1854. But many of his lyrics cannot be traced thus. He bore a part in founding the *Atlantic Monthly*, and was one of its writers from the start. Of his *Home Ballads*, etc. (1860), the *London Athenæum* said, "Here is poetry worth waiting for, and a poet worth listening to." In *War Time*, etc. (1863), contained some of his most fiery deliverances. *National Lyrics* (1865) was a small volume of selections. His *Prose Works* were collected in two volumes in 1866. With the abolition of slavery and the restoration of the Union, the great cause he had championed so earnestly was won, and the fighter could lay aside his weapons and turn gladly to congenial themes of peace. After the tremendous war-song, "We wait beneath the furnace blast," came the triumphant *Laus Deo*. His muse, always pious, now became eminently sweet and saintly. *My Psalm* (1859) was a forerunner of *The Eternal Goodness* and *Our Master* (1867). From the last several hymns have been extracted, to be used and greatly valued both in England and in America; nowhere has the inmost spirit of Christianity been more exquisitely portrayed. *Snow-Bound* appeared 1866. *The Tent on the Beach*, etc. (1867), records a camping experience with Bayard Taylor and J. T. Fields. Several of the lyrics are among his strongest and loveliest. It was followed by *Among the Hills*, etc. (1868), *Miriam*, etc. (1870), *The Pennsylvania Pilgrim*, etc. (1872), *Mabel Martin* (1874), and *Hazel Blossoms* (1875); the last includes a few poems by his sister, Elizabeth Hussey Whittier (1816-64). On the poet's seventieth birthday, Dec. 17, 1877, the publishers of the *Atlantic* gave a memorable dinner in his honor: the *Literary World* issued a special Whittier number, with tributes in verse and prose from many eminent writers. Before this a college at Salem, Iowa, had been named from him. His later books are *The Vision of Echard*, etc. (1878), *The King's Missive*, etc. (1881), *The Bay of Seven Islands* (1885), and *St. Gregory's Guest*, etc. (1886). A complete edition of his *Works*, including both poetry and prose, has been supervised by himself (7 vols., 1888-89).

The poet and the man are not easily separable in Whittier. Vice-President Wilson said on his death-bed, "I believe him the purest man living on earth." Channing saw in him "noble simplicity of character, and the fire and energy of an ancient prophet." Whipple bore witness in 1844 to his "vehement sensibility, the stormy qualities of his mind," and "the soul of a great poet." H. T. Tuckerman in 1852 saw in him "the imaginative fervor of a devotee, both of nature and of humanity," as well as "a prophetic anathema and a bardlike invocation." Vapereau (1858) called him "full of élan and vigor." These great qualities have their defects. His task is not always perfect; his "fiery protesting spirit" is sometimes indifferent to literary detail and finish. Lowell wrote in 1864, "If the most fervid of our poets, he is sometimes hurried away by this very quality into being the most careless. His rhymes are often faulty beyond the most provincial license of Burns." That was in his polemic time, when his loveliest lyrics were not yet written. So *Fraser's Magazine* in 1859 pointed out "his faults, harshness, and want of polish," but recognized "more life and spirit and soul in his verses" than is apt to be found in those of more patient and elaborate workmen. Mr. Whittier, in a green old age spent between Amesbury and Danvers, Mass., enjoys the fruit of his faithful planting, in "love, honor, troops of friends." His life has already been written by W. S. Kennedy (1882) and by F. H. Underwood (1884). (F. M. H.)

WILDERNESS CAMPAIGN, TITE. This title is intended to include the series of engagements in the American civil war fought during Grant's overland march to Richmond, embracing the battles of the

Wilderness, Spottsylvania Court-House, down to COLD HARBOR, already described in this work. It comprises a succession of great conflicts and skilful marches, occupying a single month of time (from May 3 to June 3, 1864), which radically changed the aspect of the war and placed the army of the North in position to successfully terminate the long-continued struggle. The whole campaign demands to be dealt with as but a single event of the war, its several incidents being parts of one great whole.

From the battle of Gettysburg, in July, 1863, to the beginning of May, 1864, no important military events had taken place in Virginia, the operations of the armies being confined to inconsequent marches in unsuccessful efforts to obtain advantages of position. On March 9, 1864, Gen. Ulysses S. Grant was made commander-in-chief of all the United States armies with the rank of lieutenant-general. He at once placed Sherman in command of the Western armies and took the field in person with the Army of the Potomac, though Meade still retained its immediate command. Grant's plan embraced a movement in concert of all the armies of the Union. The Army of the Potomac at that time lay just north of the Rapidan, a branch of the Rappahannock River, facing the Confederate Army of Northern Virginia, under Gen. Robert E. Lee, which lay south of the Rapidan with a strongly-intrenched position at Mine Run. The force under Gen. Grant is stated by himself to have been about 116,000 men; that under Lee is claimed by Confederate historians to have been only 64,000 men, but is estimated by Grant at 80,000. Such discrepancy in numbers as existed was negated in the succeeding engagements by the reversed relations of the two armies, Grant constantly fighting on the offensive, Lee usually on the defensive and behind intrenchments.

Shortly after midnight, on the morning of May 4, 1864, the movement of Grant's army toward the Rapidan began. At the same time Butler with 20,000 men moved from Fortress Monroe up the south side of the James River, and two days afterwards Sherman advanced from Chattanooga on his march towards Atlanta. The grand movement of all the armies had simultaneously begun. On the morning of the 4th the right wing crossed the Rapidan, followed during the day by the remainder of the army. Grant states in his *Memoirs* that he expected severe opposition in crossing the river, and considered that he had gained a great advantage in being suffered to cross unopposed. He believed that his success was due to Lee being taken by surprise by the suddenness of the advance movement.

The army now pushed immediately into that difficult country known as The Wilderness, in whose wilds Hooker had received so severe a repulse just a year before at Chancellorsville (*q. v.*). The region thus named was an exceedingly difficult one for military operations, being covered by a dense thicket of second growth, replacing the primeval forest which had been cut to supply fuel to neighboring smelting furnaces. This thicket extended for miles but was intersected by several roads, by which alone could troops be moved. The right column pushed directly into the Wilderness, the left to Chancellorsville, where it bivouacked for the night. Grant hoped that another day's march would take him through this region and that by a rapid advance on Gordonsville he might place himself in the rear of Lee's army. In consequence, early on the morning of the 5th, the whole army was put in motion for this purpose.

Lee, meanwhile, was well aware of the advantages of the Wilderness as a battle-ground, its intricacies being familiar to him and his generals while unknown to his opponents. He had already gained a victory over a superior force there and hoped to do so again. He therefore resolved to give Grant battle in those wilds. The thicket was traversed by a turnpike and a

plank road which ran eastwardly, nearly parallel to each other, from Lee's head-quarters near Orange Court-House. Along these roads Lee's army advanced on the morning of the 5th, Ewell's columns following the turnpike, the more northerly road, and Hill's the plank road. Longstreet's division, which had been stationed at Gordonsville, 20 miles off, did not arrive in time to take part in the battle of that day. This was the case also with Burnside's division of Grant's army, which had been lying on the Rappahannock.

Grant's army had not advanced far before the heads of the enemy's columns were felt. It was at first supposed that this was but a strong rear-guard to cover Lee's retreat, and dispositions were made to sweep it away and seize the intrenchments on Mine Run, the day being well advanced before it was clearly perceived that Lee's army was there with the intention of fighting. The affray opened with a struggle of skirmishers and of small parties of cavalry and infantry sent to their support, but action in force did not begin till about noon, when Ayres's and Bartlett's brigades of Griffin's division were sent through the thicket to the right and left of the turnpike to disperse the force in front. The Confederates were driven in, not being prepared for this onset, and a larger force might have crushed Ewell's corps had the true state of the case been known to the Union commanders. But the danger to the Confederates was averted by the quick advance of Stewart's brigade and the timely arrival of Rodes's division, these new troops at once attacking vigorously. Orders had been issued to support Warren's advanced brigades by the left of Sedgwick's corps, but the passage through the thicket proved so difficult that Ayres and Bartlett were hurled back before support could reach them. The fighting was desperate and ended in a decided advantage to the Confederates, who captured two guns and a number of prisoners and won the contested ground. Gen. Wadsworth, who had advanced to co-operate with Griffin, went somewhat astray in the woods and was met by a flank fire which drove him back in some confusion. On the left of Wadsworth the brigade of McCandless found itself isolated and nearly surrounded, and lost two full regiments in the effort to escape from its dangerous position. The result of the engagement was a loss of about 3000 men to Warren's corps and the possession of the contested ground by the enemy, Warren retiring to form a new line a little in the rear. Shortly after 1 p. m. the head of the Sixth corps, which was advancing to support the Fifth, was attacked by Ewell. In the conflict that ensued the Confederates were at first repulsed, then the Sixth was driven back by a furious charge of Rodes's division, and finally the Confederates were again driven, the Union forces holding the ground. This ended the fight for the day in that quarter.

Two hours before Griffin's advance Grant had fathomed Lee's intention to give battle in the Wilderness and made the necessary preparations. To Hancock, who was advancing with the Second corps, he sent word to march with all haste by the Brock Road which crosses the plank road nearly at right angles, while Gen. Getty, of the Sixth corps, was ordered to hold the junction of these roads with his division until joined by Hancock. He did so, though pressed severely by Hill, who was seeking to gain possession of the same strategic point. Hancock's advance reached Getty's position about 3 p. m., and soon the whole Second corps was there and the junction secured. Shortly afterward Hancock, who had begun to throw up breastworks, was ordered to advance on Hill and drive him back. A sanguinary battle ensued at close quarters, but Hill maintained his ground firmly until after nightfall, when the fighting ceased, the combatants resting for the night so near each other that both drew water from the same brook. Thus ended the first day's battle in the Wilderness.

The battle was resumed early in the morning of the

6th. During the night Longstreet had bivouacked near the intrenchments on Mine Run, and was ordered to take position on Hill's right; while Burnside arrived before daybreak and marched to occupy the position between Warren and Hancock. Grant's line of battle, now fully formed, extended from Todd's Tavern on the Brock road to near Germanna Ford, crossing the turnpike and plank road nearly at right angles and presenting a front of about five miles. Sedgwick occupied the right; Warren joined him on the left, his line crossing the turnpike; Burnside took position on Warren's left, and Hancock lay on the extreme left, occupying the Brock road and its junction with the plank road. Lee's army remained as on the day before, Ewell on the turnpike, facing Sedgwick and Warren; Hill on the right, across the plank road; while Longstreet was advancing towards his position on Hill's right, facing Hancock.

So stood the opposing armies on the morning of May 6, ready to engage in one of the most singular and desperate conflicts the world had ever known. Swinton well states the case: "Manœuvring here was necessarily out of the question, and only Indian tactics told. The troops could only receive direction by a point of the compass, for not only were the lines of battle entirely hidden from the sight of the commander, but no officer could see ten files on each side of him. Artillery was wholly ruled out of use; the massive concentration of 300 guns stood silent, and only an occasional piece or section could be brought into play in the roadsides. Cavalry was still more useless. But in that horrid thicket there lurked 200,000 men, and through it lurid fires played, and, though no array of battle could be seen, there came out of its depths the roll and crackle of musketry like the noisy boiling of some hell-caldron that told the dread story of death."

Grant recognized the difficulty of the situation and gave but a single general order: "Attack along the whole line at five o'clock." Lee, however, began the battle, by an assault a little before this hour, with the purpose, as is asserted, of occupying the Union lines till Longstreet could get into position, when he hoped by a sudden and vigorous attack on Hancock's flank to drive his antagonist back to the Rapidan. If such was his design it was defeated, Longstreet not reaching his position as early as hoped for. The battle began in a fierce musketry assault on the extreme right of Sedgwick's corps and a desperate effort to break through his lines. This was easily repelled, and Sedgwick made a partial advance, while at the same time Warren and Hancock attacked the foe in their front. Hancock's movement was at first successful. The Confederates were forced out of their rifle-pits, many prisoners with five battle-flags were captured, and Hill's troops driven back in confusion. At this critical juncture Anderson's division of Hill's corps came up and checked the retreat, and the head of Longstreet's column, which had been marching to flank Hancock, made its appearance in front.

It was now 9 A. M. Hancock reformed his lines, which had received reinforcements from Burnside, and resumed his advance, but found himself speedily checked by a large force. Longstreet had been recalled from his flanking march and ordered to Hill's assistance, and Hancock had the greater portion of the Confederate army before him. The battle that ensued was fierce and sanguinary, Hancock making vigorous efforts to break the strong lines in his front, and losing heavily in the effort. About 11 A. M. a fierce assault was made on his left, by a strong force which Lee had sent to carry out his original plan of flanking the Union line with the hope of doubling it up, and driving the whole army back to the Rapidan. Hancock was forced to fall back before this overwhelming charge, Gen. Wadsworth falling with a bullet through his brain as his line was forced to retreat.

At this point in the contest a serious misfortune befell the Confederate cause. Longstreet was pressing

forward with the vigor which he had shown since his first arrival on the field, pushing back Hancock in front and endeavoring to seize the Brock road on his flank, where he himself fell by a bullet from one of his own men. He was riding, with his staff, in front of his column, when he came upon the van of his flanking force. His men, mistaking the group of officers for Union cavalry, fired, and Longstreet fell with a severe wound, which disabled him for months. This accident seriously deranged the Confederate plans. The lines were thrown into confusion and the advance ceased, while Lee, as soon as he heard of the misfortune, hurried to the spot to take charge in person of the important movement he had ordered. This check was of vital importance to Hancock. While Lee was rallying and reforming the troops and preparing for a fresh advance, a labor which consumed four hours, Hancock had reoccupied his intrenchments on the Brock road and made preparations for the threatened attack.

At 4 P. M. the columns of Longstreet and Hill, led by Lee in person, advanced in serried masses upon Hancock's position, and vigorously assailed the line, which lay behind a strongly built breastwork of logs. The contest soon became hot and furious. The incessant volleys of musketry set fire to the woods, which quickly became filled with flame and smoke. Soon the Union breastworks were on fire, and ere long the whole line of logs was a mass of seething flames, the smoke and ashes being driven by the wind in the face of the Union troops. The battle went on through smoke and flame, a portion of the breastworks not yet on fire being taken by a fierce Confederate charge. The moment was a critical one, but Col. J. W. Hoffman rushed forward with a small body of men, drove the assailants out, and retook the works. This, as Hancock declared, saved the day on the left. The intrenchments had proved too strong to carry, and no further effort was made.

On the right the fighting was less severe. Sedgwick had made a strong effort to carry Ewell's intrenched lines, and had lost heavily in doing so. Warren had remained mostly on the defensive. As night approached it was supposed the battle was at an end, but Lee had another surprise in store. Just at sunset a heavy column, led by Gen. Gordon, advanced from Ewell's extreme left, and fell heavily and unexpectedly on Sedgwick's wearied troops, who were utterly unprepared for such an assault. It was a moment of peril. The right wing of the army seemed in imminent danger. The charging column fell first on the brigades of Seymour and Shaler, of Rickett's division, drove them back confusedly, and captured several hundred prisoners, including both commanders. But Sedgwick swiftly hurried men to the defence, the Confederate advance was checked, and the darkness of night soon put an end to the violently contested battle. During the day the cavalry had taken no part, except a brief contest between Sheridan and Stuart in the open country far to the left of Hancock's lines.

The losses were severe. Careful estimates place the Union loss during the two days' battle at nearly 18,000 men, of whom 6000 were made prisoners. The Confederate loss was probably about 11,000. Fierce as the battle had been no advantage in position was gained by either party. The Union army rested during the night on precisely the grounds it had occupied in the morning. With the dawn of the 7th the men rose ready to renew the battle, if necessary. But Lee had evidently had enough of offensive fighting, great as was the advantage to him of his knowledge of the ground. The skirmish line sent out at daybreak found the Confederates behind intrenchments, to attack which, in that impracticable wilderness, would have been a desperate and dangerous attempt for the Union army. Grant at once decided not to do so, but to get out of the wilderness and into more open country without delay. Thus ended the first act of the Wilderness campaign.

At 9 P. M. on the 7th Warren moved from his lines

and began a march along the Brock road, towards Spottsylvania Court-House, 13 miles distant. Hancock was to follow him, and Sedgwick and Burnside to march by way of Chancellorsville. The hope was entertained that the point in question could be reached before Lee became aware of the movement. Warren, however, met with obstructions, first from Union cavalry which occupied the road, and afterward from barricades of heavy trees which had been felled across it. Hours were lost in consequence, and it was 8 A. M. before the head of the column reached a point 2 or 3 miles from the Court-House. No opposition had been met except from dismounted cavalry, but at this point an unexpected and severe check was received, in a murderous fire of musketry which hurled the leading brigades backward, until met by Warren, who rallied and reformed them. Griffin's division was similarly received, and Warren's corps, as its divisions successively came up, formed into line of battle, and at once began to intrench.

This check was due to the head of Longstreet's column, then commanded by Gen. Anderson, which was already on the ground. The attempt to surprise Lee by a flank movement had, in fact, failed. He had been apprised by Gen. Stuart that the Federal wagon trains were moving southward. At once conceiving of Grant's design, though ignorant of the threatened point, he ordered Anderson to move from the breastworks, and encamp at a point where he would be in position for a march on Spottsylvania in the morning. The burning woods, however, rendered bivouacking impracticable, and Anderson marched on through the night, so that it was rather by accident than design that he reached Spottsylvania in the early morning, in time to throw the head of his column across Warren's line of march. Mingled accident and design had foiled the attempt to flank Lee's army.

The remainder of the day was consumed in the march of the two armies, and night found them both in place, Lee's veterans planted directly across the southward course of the Army of the Potomac. There had been several collisions during the day, but no events of importance. Anderson had occupied a range of hills about a mile north and north-east of the Court-House, where he hastily intrenched, the remaining corps of the army, as they came up, falling into line with him and throwing up defensive works. This process continued during the 9th, the Union forces similarly intrenching, so that by nightfall each army was covered by a continuous line of formidable breastworks.

Grant had decided to attack on the 10th. On the preceding evening Hancock had crossed with three of his divisions the Po River, a small affluent of the Mattaponi. Two of these divisions were ordered to be recalled to take part in the designed attack. The third, Barlow's, soon found itself in a perilous position. While it was repelling a sharp attack, the woods between it and the river burst into flames, and it became necessary to fight the Confederates and the fire at the same time. The stream was recrossed, but not without heavy loss, the assailants also losing heavily. During the day two assaults were made on Lee's lines, one at 10 A. M., the other at 3 P. M. The point assailed was a thickly wooded eminence known as Laurel Hill, which was crowned with earthworks. Both attacks were repulsed with heavy loss to the assailants. At 5 o'clock the main assault began. The Second corps had now joined the Fifth, and Hancock and Warren led their men against the position which had already been twice attacked. A desperate struggle ensued. The Union lines advanced with great intrepidity, and penetrated the breastworks at one or two points. But they were met with a storm of shot and shell that flesh and blood could not withstand, and were driven back with fearful slaughter. An hour later they marched to the assault again, and were again repulsed with heavy loss. The attempt was attended with far more serious consequences to the Union than to the Confederate troops.

Nearly 6000 of the former had fallen, while the latter had lost not more than 600. The losses of the whole day's dreadful work, however, were more evenly distributed. It is stated that the total losses by death, wounds, and captivity were 9000 Union and 8000 Confederate troops.

Thus ended the first day of the battle of Spottsylvania Court-House. Great as were the difficulties he had met and the losses he had sustained the determination of Gen. Grant was not weakened. On the morning of the 11th he sent to the secretary of war a despatch whose closing words have become historical: "I propose to fight it out on this line, if it takes all summer."

The 11th passed in preparations for another battle. Grant had determined to attack Lee's line at its right centre, which seemed a vulnerable point. We are told by Southern historians that Lee had weakened this point by the withdrawal of artillery, having reason to believe that Grant was contemplating another flanking march, and that a deserter had conveyed information of this fact across the lines. Hancock's corps was designated for the assault, and moved into the requisite position during the night. In the early morning, under cover of a dense fog, the attacking column swiftly and silently advanced towards the weakened salient, held by Johnson's division of Ewell's corps. The Confederates first knew of their danger by a sudden outburst of cheers, as Barlow's and Birney's brigades dashed upon and across the works, breaking down all opposition, and capturing Johnson and almost his entire division while unsuspectingly at breakfast. In addition two brigades under Gen. Stewart were taken, with nearly 30 guns and many colors. More than 3000 prisoners were captured. Lee's army was cut in two, and the most desperate efforts were necessary to avert irretrievable disaster.

One of the most terrible conflicts of the war ensued. Lee hurried up troops from both directions, while the flying Confederates, who had been pursued through the woods for about a mile, rallied behind a second line of breastworks and turned on their pursuers. The reinforcements from Hill's and Longstreet's corps drove back Hancock's men to the position they had captured, and heavy masses of troops pouring upon them confined them within the triangular area of the salient. On the other hand the Sixth corps was sent to the assistance of Hancock, while Warren and Burnside attacked the Confederate lines along their whole front. These lines, however, were so strong that, despite the attack, their defenders could spare men for the central struggle. Here the fight was furious and sanguinary. Lee was determined to retake the lost portion of his works, and hurled all the force he could gather on Hancock. The battle was hand-to-hand; both parties at times planted their flags on the breastworks within a few feet of each other. The carnage on both sides was dreadful, but despite Lee's persistence all his efforts were in vain. He continued to fight till after night had fallen, when he withdrew his shattered columns, leaving Hancock in possession of the works he had captured.

Thus ended the battle of Spottsylvania Court-House, one of the most desperately contested and sanguinary of the war. The losses during the campaign, from the crossing of the Rapidan to the close of the battle just described, were, according to the official report, 29,410 men killed, wounded, and missing. The Confederate loss is not known. It was less severe than the Union, in consequence of their defensive attitude and the strength of their intrenchments, but was severe, and probably greater in proportion to the disparity of forces than the Union loss. Lee could not as well as Grant afford to have his army depleted. On the morning of the 13th he withdrew his troops behind an inner and shorter line of intrenchments. His position seemed as strong as ever, and Grant hesitated to attack, confronting the enemy till the 15th, on which day an unsuccessful

ful attempt was made to carry a portion of the Confederate works. The repulse of this column was avenged on the succeeding day by a similar repulse of Ewell, who had been sent by Lee to demonstrate against the Union right, under the belief that another flanking movement was in progress. Ewell was repulsed, with a loss of about 900 men.

During these events the cavalry, under Gen. Sheridan, had made a dash on Richmond. The North Anna was crossed on the 9th, much railroad property and military stores destroyed, and on the 11th some Confederate cavalry under Gen. Stuart was encountered a few miles north of Richmond. A sharp fight ensued, in which the Confederates were routed and their general mortally wounded, the latter a severe loss to their cause, since Stuart had proved himself one of the ablest cavalry leaders of the war. Sheridan pushed on and attacked the defensive works of Richmond, but found them too strong and too well defended for success in a cavalry charge. He leisurely returned and rejoined the army on May 25.

Meanwhile the army was in motion. On the 20th it disappeared from the front of Lee's army, and began a flank march to turn the position of Spottsylvania. It had sent its sick and wounded men and its prisoners to the rear, received abundant reinforcements and supplies, and moved jubilantly forward, restored to its original strength. The movement was hardly begun before Lee was aware of it and had put his own army in motion. Once more a race between the two armies began, in which Lee, having the shorter line, had the advantage. The point aimed for was Hanover Junction, an important railroad intersection, on the south side of the North Anna River. Lee occupied this position on the 22d, immediately threw up defensive works, and when Grant arrived on the 23d, it was to find his antagonist again in his front, strongly entrenched, and with a river as part of his line of defence. Lee's army occupied a singular position. Its centre touched the stream while both wings were thrown back at an obtuse angle, facing the corps of Warren and Hancock respectively. This put Grant at a decided disadvantage, for after his two wings had crossed the stream they were isolated from each other, and to reinforce either wing from the other it was necessary to make a double passage of the river. Lee's army, on the contrary, lay compactly behind its intrenchments. Despite this disadvantage Grant at once attempted to force his antagonist from his path. Warren, on the right, reached the river at an unguarded ford, and crossed without opposition. Ere he had advanced far, however, he was attacked by a strong Confederate force, and a severe conflict ensued, which ended in the repulse of the Confederates with the loss of nearly a thousand prisoners. Warren at once proceeded to intrench his chosen line without further opposition.

Hancock crossed on the left, but not with the same ease. A division of Longstreet's corps held the river at this point, occupying the bridge and a redan-shaped battery in front of it. This battery was stormed and taken, and during the night the Confederates attempted to burn the bridge. Failing in this, they withdrew from their advanced works to a stronger position in the rear, and Hancock crossed in the morning without opposition. At the same time Wright crossed above and joined Warren's corps. Burnside, in the centre, endeavored to cross, but without success.

The position of the Army of the Potomac was a perilous one. Its two wings were on the south side of a river difficult to cross and liable at any moment to a sudden swelling by rains, while the weaker centre lay north of the river. Lee's army lay between the two wings, isolating them from each other, and holding the river so strongly in front of Burnside that he was unable to cross. For two days the armies lay thus facing each other, when Grant, evidently considering that it would be madness to risk a battle under such disadvantages of position, secretly withdrew his forces to the

north of the river on the night of the 26th, and put his army in motion on another flanking movement. This march was made well to the eastward, so as to avoid a blow on the flank, its objective point being the passage of the Pamunkey, an affluent of the York formed by the junction of the North and South Anna Rivers. Possession of this point would give Grant an excellent water base of supplies at Whitto House, while forcing Lee to abandon the line of the rivers named.

Sheridan led the way with the cavalry in this movement, and was rapidly followed by the infantry, the Pamunkey being reached and crossed on the 28th, at Hanover town, about 15 miles from Richmond. Lee had at the same time abandoned his works on the North Anna, and marched quickly southward by the shorter line, and awaited Grant on the Totopotomoy, near Mechanicsville. There had been a cavalry struggle in this vicinity on the 28th, Sheridan driving back Hampton and Fitzhugh Lee, who lost nearly 800 men, his loss not being more than half that number. On the 30th the advancing infantry came into contact with Lee's forces, and some sharp fighting took place, with no decisive advantage on either side. Grant, deeming it injudicious to make a direct attack on Lee's front, moved slowly by his left flank towards the Chickahominy, while Lee kept pace with him by a similar movement to his right, confronting him at every stage. This movement continued till a flank of each army rested upon the Chickahominy, both armies protecting themselves with breastworks at every point of the movement. They were now on the old battle-field of Gaines' Mill, where so fierce a struggle had taken place in 1862. (See PENINSULAR CAMPAIGN.) For the details of the battle which succeeded, and the conclusion of Grant's overland march to Richmond, see COLD HARBOR. (C. M.)

WILKES, CHARLES (1801-1877), naval officer and explorer, was a nephew of the celebrated John Wilkes, of England, and was born in New York city. He entered the U. S. navy as a midshipman in 1818, and served five years on the Mediterranean and Pacific squadrons. In 1826 he became a lieutenant, and in 1830 was assigned to the department of charts and instruments, where his bent for science was exercised. In 1838 he received the important appointment of commander of the U. S. Exploring Expedition, for which great preparations were made. With six vessels well equipped and an able staff of officers (Prof. J. D. Dana being the geologist and mineralogist) he sailed from Norfolk, Va., Aug. 18, and visited Madeira and the Cape Verde Islands. Touching South America at Rio de Janeiro, he coasted down the Atlantic and up the Pacific as far as Callao, and thence crossed the ocean to Australia, stopping at the Samoan Islands and sundry other groups. In December, 1839, he started from Sydney on a voyage of discovery along the Antarctic Continent, as far as latitude 101 E. The Fiji and Sandwich Islands were next visited and observations taken on the summit of Mauna Loa. After examining the Californian and Mexican coasts in 1841, the expedition sailed for Borneo and the Cape of Good Hope and returned to New York June 10, 1842, after nearly four years at sea. Charges were soon preferred against Wilkes by some of his subordinates; he was court-martialled, acquitted, and promoted to commander the next year. His memorable *Narrative* of the expedition, one of the most notable of government publications, came out in six quarto volumes in 1845, yet material remained for more. An abridgment appeared in 1851, a volume on *Western America* in 1849, and one on the meteorological observations of the expedition in 1851. The London Geographical Society honored Wilkes with a gold medal in 1848, in recognition of the gains to science through his labors; of these there was in general but one opinion, though some of his observations on the Antarctic Continent were afterwards contested by those of H. M. S. *Chal-*

lenger. He was made captain in 1855, and the next year published *Theory of the Winds*. After many years of special duty at home the outbreak of the rebellion brought him again to the front, and afforded an opportunity of supposed service and abundant distinction of which he was just the man to avail himself. He was in the West Indian waters in search of the Confederate cruiser *Sunter*, when, in the Bahama Channel, he came upon the British steamer *Trent*, carrying the mails and having on board as passengers two commissioners of the Confederate States, Mason and Slidell, accredited respectively to France and England. Valuing the end far above the means, and taking the law into his own hands, he promptly overhauled the vessel, Nov. 8, 1861, disregarding all protests, took from her the Confederate officials and conveyed them to the North as prisoners of war. No early event of the conflict caused greater sensation. In the fervor of patriotic feeling legal questions were apt to be overlooked. Wilkes was loaded with demonstrations of popular applause and received the thanks of Congress. But in England his action was regarded in a very different light; the British ministry inclined to make a declaration of war for the outrage on its flag, but Prince Albert is said to have caused the way to be left open for reconsideration by the American government. It was plain on reflection that international law had been violated with however praiseworthy intentions. The U. S. government bowed to necessity and released the commissioners, and Secretary Seward, by an adroit stroke of diplomacy, represented Great Britain as having acceded to the application of international law long insisted upon by America. Yet Wilkes did not suffer, but was presently made a commodore in 1862. Placed in command of a flotilla on the Potomac, he destroyed City Point, Aug. 28. In 1863 he was busy along the Southern coast in enforcing the blockade and capturing blockade-runners. He was retired July 25, 1866, with the rank of rear-admiral. He died at Washington, Feb. 8, 1877. A hero is nearer to the public heart than a scientist, and Wilkes' great services to geographical and other knowledge hardly made him so famous as the momentary deed of a patriotic but reckless impulse, which might have involved ruinous consequences to his country had it not been quietly but practically disavowed by the cooler heads of his superiors. (F. M. B.)

WILKINSON, JAMES (1757-1825), for some years commander-in-chief of the U. S. army, was born in Charles co., Md., and at 18 was a captain in the Revolutionary war. He served under Arnold and Gates, became adjutant-general to the latter, and carried to Congress the tidings of Burgoyne's surrender. He was to some extent involved in the Conway cabal, and left the army as a colonel in 1778, but the next year was appointed clothier-general to it. Going into business in Kentucky, he rendered great service to that region by opening the Mississippi to its trade; having gone to New Orleans in 1787 with a flat-boat, he managed not only to sell his cargo, but to obtain free entrance for others and for himself a contract to supply tobacco. This won him great local repute and popularity, and in 1789 Louisville sent 25 flat-boats loaded with provisions to New Orleans. His adventurous and speculative character was never above reproach; he was soon accused of complicity with Spanish intrigues in Kentucky, then disaffected. He took part as lieutenant-colonel in the expedition against the Indians on the Wabash, was commissioned brigadier-general in March, 1792, and commanded the right wing of Wayne's army at the Maumee, Aug. 20, 1794. He was commander-in-chief, 1796-98, and again, 1800-12, though laboring under constant suspicions and accusations of the gravest nature. He was one of the two commissioners who received the cession of Louisiana from the French in 1803, and in 1805-6 was its territorial governor. At this time he was charged, not without apparent reason, with corruption and

complicity with the treasonable plans of Burr, with whom he had sustained close relations and conducted a correspondence in cipher. The charges were embodied by Daniel Clark, of New Orleans, in an octavo volume of 349 pages (1809). The inmost facts of this connection and the general's real motives are matters of conjecture; but he suddenly assumed an attitude of vehement and energetic loyalty, put Burr's agents to the question, arrested certain persons as conspirators, sent a report to Pres. Jefferson in October, 1806, and made vigorous preparations to repel any hostile or insidious attack. The affair made a great stir, not only on the spot, but throughout the country and at the seat of government, where it presently became a party issue. Jefferson and his followers defended Wilkinson, while the Federalists accused him of illegality and abuse of power in the arrests. Randolph denounced him in Congress, and was challenged to a duel in 1808. Wilkinson's conduct was a burning question for four years; he was indicted by the grand-jury, investigated by two committees of Congress, and tried by a court-martial, in which Tancy pleaded his cause and procured an acquittal in 1811. After this he went back to New Orleans, improved the defences of the city, and came into collision with Jackson. He received a major-general's commission in March, 1813, reduced Mobile the next month, and in May went to the Canada border, where he accomplished nothing. His movement on Lake Champlain in 1814, through lack of co-operation between himself and Wade Hampton, was such a fiasco that he laid down his command and asked for a court-martial, by which he was again acquitted. At the reorganization of the army in 1815 he was not included, but received a pension from Maryland, which adhered to him as a favorite son. Disgusted with the ingratitude of republics, he put forth his own side of the story in *Memoirs of My Own Times* (3 vols., 1816), purchased an estate near the city of Mexico and spent his latter years in self-imposed exile, dying there Dec. 28, 1825. His large volumes are vigorously written and show no mercy to his numerous enemies, but documentary evidence has been published which establishes his guilt. See Gayarré's *History of Louisiana: Spanish Domination* (1854).

(F. M. B.)

WILL in law denotes the disposition of one's property to take effect after death. Wills See Vol. XXIV. are usually written, yet they may be p. 570 (p. 600) unwritten or nuncupative. To make Am. Rep.) a valid nuncupative will, the person must be *in extremis* and in immediate prospect of death. In England the power of making such a will is restricted by statute to soldiers in military service, *i. e.* on an expedition, and sailors at sea. In some of the United States these wills are specially restricted by statute, while in others they exist as they did in England previous to the limiting statute, *i. e.*, confined to a small amount of personal estate. Wills written in pencil have been held valid.

The Testator's Capacity.—He must be of the age of discretion, which is fixed by statute in England and in most of the United States at twenty-one years. Under the common law in England aliens could not devise real estate, but in the several States this has been altered by statutes. Formerly married women did not have testamentary capacity, but, together with most other of their disabilities, this has very generally been removed by statutes. In the case of wills of persons who are blind or deaf and dumb, there must be proof that the testator understood the contents of the will and communicated with the witnesses. Idiots are wholly incapable of executing a will; so also are lunatics, except during a lucid interval allowing the exercise of memory and judgment. It has been held that mere weakness of understanding will not invalidate a will, if the testator were capable of comprehending the object in view. Delirium, whether from disease or stimulus, while the paroxysm continues to

such an extent as to deprive a person of the right exercise of reason, is a sufficient impediment to the execution of a will. It differs from ordinary insanity, however, in that there is no presumption of its continuance. Senile dementia, or loss of mental faculties through old age, if shown, will also invalidate a will. If, however, the testator has sufficient memory left to collect the elements of the transaction, i. e., the amount and kinds of his property, the number of his children, etc., and to form an understanding judgment concerning them, he has proper testamentary capacity, though his mind be not so strong as it once was. Fraud or undue influence, by which a person is induced to make a will, will invalidate it.

The Mode of Execution.—The statutes of the States differ as to the number of witnesses required. In Connecticut, Florida, Georgia, Maine, Maryland, Massachusetts, Mississippi, New Hampshire, South Carolina, and Vermont, three witnesses are required. In most of the other States two are sufficient, though in some the number is not specified. As a general thing the witnesses must sign in presence of the testator, and should not be interested parties. The testator may sign in their presence or may produce the instrument already signed, and acknowledge his signature in their presence.

Revocation.—A will may be revoked by the testator effacing his signature thereto, or by an evident attempt on his part to destroy it. The same capacity is requisite to revoke as to make a will. Moreover, the making of a new will purporting to be testator's last will, and containing no reference to any other paper, and being a disposition of all the testator's property, and so executed as to be operative, will be a revocation of all former wills, notwithstanding that it contains no express words of revocation. A will is revoked by the subsequent marriage of the testator and the birth of issue. This is generally regulated in the different States by statute.

Republication.—As a general rule a will revoked can only be republished by an instrument of as high a nature as that which revoked it, e. g., a will revoked by written declaration cannot be republished by parol; such a republication has, however, been allowed in Pennsylvania.

Probate.—A will must be proved in the probate court. In England the probate of a will is not evidence in regard to real estate, but in the United States the probate courts have, as a general thing, exclusive jurisdiction of wills and estates, whether the property be real or personal. The probate of wills passing realty is governed by the law of the place where it is situated; of personalty by the law of the testator's domicile. Any one interested in a will may compel probate of it by application to the probate court, who will summon the executor or person having the custody of it. The witnesses must appear and prove the authenticity and execution of the will and the competency of the testator. If, however, they are absent from the State, deceased, or disqualified, their handwriting must be verified. Wills more than thirty years old, appearing regular and perfect and coming from proper custody, are said to prove themselves. Wills lost, mislaid, or stolen at the time of the testator's death may be admitted to probate upon proper proof of the loss and execution. In most of the United States there are statutes providing for the probate of foreign wills by exemplified copy.

As a general rule a will is said to speak from the death of the testator, unless a contrary intention be very plainly indicated.

Parol evidence is admissible to show the state of the testator, the nature and condition of his property, his relation to the contestants, and all the surrounding circumstances. It is inadmissible to supply any word or defect in the will or to indicate the testator's intention, which is to be gathered from the language of the instrument alone. As a general rule where a

wrong name has been inserted by the scrivener, parol evidence is not admissible to carry into effect the testator's intention, though the contrary has been held in some instances. Where there are portions of a will wholly incapable of standing with other portions, generally speaking the later provision will control, as being the latest declaration of the testator's intention.

(T. R.)

WILLARD, EMMA HART (1787-1870), educator, was born at Berlin, Conn., Feb. 23, 1787, the youngest but one of seventeen children. She entered upon her vocation at seventeen, was invited to Westfield, Mass., in 1807, soon removed to Middlebury, Vt., and there was married in 1809 to Dr. John Willard, State marshal. His fortune becoming impaired five years later, she reopened her school and by degrees introduced new studies. Her plans for the higher education of girls, previously little thought of, were so extensive as to require State aid and practically to aim at a college. They were laid before Pres. Monroe, and, in an *Address to the Public*, 1819, before the New York Legislature. In that year her school was removed to Waterford, N. Y., chartered, and promised public help, of which little came. She was induced to remove to Troy in 1821 by the offer of a large building and other facilities. Over 300 pupils entered at once, and the seminary became famous. For 17 years she conducted it with eminent success, aided by able teachers, especially her younger sister, Mrs. Almira Lincoln (afterwards Mrs. Phelps), who was with her 1823-32. Her series of text-books began in 1822 with a *Geography*, and was continued in sundry publications of which over a million had been sold at her death. Her *History of the United States*, called by another name in its first edition 1828, was translated into German and Spanish and much used by Daniel Webster. Her *Universal History* was very widely circulated. Her *Poems* (1830), suppressed by her, contained the familiar lyric "Rocked in the Cradle of the Deep;" Lafayette shed tears at another in his honor, 1825. A foreign trip in 1830-31 furnished material for a *Journal and Letters* (1833), the profits of which went to found a missionary school at Athens. Dr. Willard died 1825, and in 1838 his widow gave up her school and contracted an unfortunate marriage from which she was released by a divorce. After this she travelled much, took part in educational conventions and the like, and published treatises on *The Circulation of the Blood* (1846), and on *Respiration* (1849); *Last Leaves of American History* (1849); an *Autobiography* (1853); *Morals for the Young* (1857); and *Tu Media* (1862). The last followed sundry efforts to avert the civil war, wherein she overrated her influence. She died at Troy, N. Y., April 15, 1870. Her *Life* was written by Dr. John Lord (1874).

WILLARD, FRANCES ELIZABETH, noted for her temperance work, was born near Rochester, N. Y., Sept. 28, 1839. Her parents removed to Wisconsin and she was educated at the Milwaukee and Northwestern Female Colleges. She taught in several schools and academies and contributed to various journals. While teaching in the Pittsburg Female College in 1863 she wrote a memoir of her sister under the title, *Nine Beautiful Years*. In 1868 she went to Europe and spent eighteen months there. On her return she began lecturing on reform in women's education, and in 1871 she was made president of the Women's College at Evanston, Ill. In 1874 she was made secretary of the Women's Christian Temperance Union, and in 1876 she assisted Mr. Dwight L. Moody in his evangelistic work. In 1878 she became chief editor of the Chicago *Evening Post*, but afterwards resigned to devote all her time to temperance work. As president of the Women's Christian Temperance Union she has travelled through the country addressing legislatures and people in behalf of temperance and prohibition.

WILLIAM II., emperor of Germany and king of

Prussia, eldest son of the crown-prince of Prussia (afterwards Emperor Frederick III. of Germany) and Victoria, princess-royal of England, was born Jan. 27, 1859, and succeeded to the throne June 15, 1888, on the lauded death of his father after his brief reign of 99 days. His full name is in German Friedrich Wilhelm Victor Albert. He received his early education, military as well as literary, from tutors at home, and in 1874 entered the gymnasium of Cassel, where he studied till his graduation in 1877. He was then assigned to the 1st regiment of foot-guards, in which he completed his military training under the professors of the Potsdam military academy, and was soon made colonel of the hussars of the guard, of the 1st Pomeranian regiment of grenadiers, and of the 2d Landwehr regiment of grenadiers. On Feb. 27, 1881, he married the Princess Augusta Victoria, daughter of the deceased Duke Frederick VIII. of Schleswig-Holstein, by whom he has four sons, the eldest, the present crown-prince, having been born May 6, 1882. During the last illness of his grandfather, Emperor William I., the present emperor (in the absence of his father in consequence of the malady of which he died) acted as the aged monarch's representative, and at his obsequies again took the place of his father, of whom he afterwards continued to be the representative on important occasions.

On the present emperor's accession the political sky of Europe was much overcast. Both France and Russia seemed to be preparing for war, and Germany responded in the end of 1887 by an augmentation of the Landwehr and other reserve classes of her army through extending the age of service, so that she was in a condition to place 3,850,000 men in the field, while in February, 1888, a further warning was given to the suspected powers by the simultaneous publication of the Germano-Austrian treaty—defensive and offensive—to which Italy shortly after gave in her adhesion. In such conditions the military predilections of the emperor and his supposed strongly pronounced character were regarded with widespread anxiety. His first public act was an energetic address to his army and navy. This was followed by an address to his people in which he pledged himself to walk in the paths of his just and peace-loving father. The Reichstag met on June 25, and was opened by William with much pomp. In his speech from the throne he declared himself resolved "to live at peace with all men so far as in him lay." On June 27 the new king took the oath to the constitution before the Prussian Landtag and again declared for a pacific policy. In July and August he paid visits to the northern courts of Europe—Russia, Sweden, and Denmark. In the beginning of October he visited the court of Vienna, whence he proceeded to Rome on a visit to King Humbert of Italy. Before going to the Quirenal he waited on the pope, and his Catholic subjects drew good auguries from this. In September there appeared in the *Deutsche Rundschau*, excerpts from the diary kept by his late father during the eventful epoch of 1870-71, by which it was made to appear that the consolidation of Germany into an empire was due in a much higher degree to the late emperor than to Prince Bismarck, to whom the original conception had been accredited. These extracts are said to have been given by a confidant of Emperor Frederick to Professor Geffcken, who communicated them to the *Rundschau*. The emperor, and Prince Bismarck especially, were seriously offended by the publication. Prof. Geffcken was cast into prison but was finally released, though he had been threatened with trial for high treason, the revelation of state-secrets being a treasonable offence in Germany. Even the ex-empress became the object of obloquy as having connived at the publication. She had returned to her mother in England in November, 1888, and her son appears estranged from her and full of antipathy to England and English customs. In Germany this is

popularly accounted for by saying that he attributes the malformation of his left arm, which is shorter than the other and hangs listlessly by his side, to his having been brought unskilfully into the world by an English accoucheur recommended by Queen Victoria.

It is yet too early to speak with confidence of William II.'s policy and character as a ruler. From measures announced as about to be submitted to the diet in behalf of industry and of the working classes, it is inferred that he is opposed to socialistic schemes. His foreign policy is indicated by his choosing for his special confidant his war-minister, Count Herbert Bismarck, son of his great chancellor, Prince Bismarck.

A somewhat severe ear trouble prevented him from appearing much in public during the latter part of 1888. The emperor's personal appearance is in his favor. He stands nearly six feet high and is well built, though inclined to stoutness. In complexion he is a fair blonde, though his hair inclines to a darkish brown. His features are regular and prepossessing, the eyes blue and honest and capable of smiling when he is pleased, his mouth small, and nose demi-Roman. When he stands, his left hand rests quite naturally on the hilt of his sword, so that an onlooker would not readily detect the deformity; when he sits, it hangs in seemingly soldierly fashion by his left side. Some critics accuse him of coldness and unattractiveness of manner and an aggressive bluntness in speech and action with little regard to the feelings of others.

WILLIAMS, SAMUEL WELLS (1812-1884), sinologue, was born at Utica, September, 1812. He was educated at the Reusselaer Institute, Troy, N. Y., and went to China in 1833 as a printer for the American Board of Commissioners of Foreign Missions. He was engaged at Canton in printing and editing, and also visited Japan for the same purpose. From 1845 to 1848 he resided in the United States teaching. In 1853 he was made interpreter to Commodore M. C. Perry's expedition to Japan, and rendered most valuable service. In 1855 he became secretary and interpreter of the American Legation at Peking, where he assisted U. S. Minister W. B. Reed in negotiating the treaty of 1856. Returning to the United States finally in 1876, he was appointed lecturer on Chinese at Yale College, and became president of the American Bible Society in 1881. He died at New Haven, Feb. 17, 1884. Of his various text-books and dictionaries, published in China, the most important is the *Syllabic Dictionary of the Chinese Language* (1874). He is best known by *The Middle Kingdom* (1848; but greatly improved, 2 vols., 1883). He also published *Chinese Immigration* (1879). See his *Life* by his son, F. W. Williams (1889).

WILLIAMSON, HUGH (1735-1819), scholar and statesman, was born in West Nottingham, Pa., Dec. 5, 1735. His parents were Irish. After graduating at the College of Philadelphia 1757, he studied theology, was licensed to preach and admitted into the Philadelphia Presbytery, but was never ordained, and soon turned to secular pursuits. His abilities and tastes were of such varied character that he found it difficult, if not impossible, to concentrate on any one field of activity; and, indeed, he attained distinction in several which had little natural connection. He was professor of mathematics in the College of Philadelphia 1760-3, then turned to medicine, and went abroad in 1764 to study at Edinburgh, London, and Utrecht. Returning to Philadelphia, he entered upon successful practice, but his own health became impaired. Cultivating astronomy and other sciences, he made observations on the transits of Venus and Mercury in 1769, and studies of climate in 1770: these were inserted in the *Transactions* of the Philosophical Society. He went to the West Indies in 1772, and the next year to England to solicit funds for an academy at Newark, Del. The political feeling against the colonies prevented success for such a mission. Questioned before the Privy Council in February,

1774, as to the state of things in America, he told the story of the destruction of the tea at Boston, and frankly said that war was probable if the policy of coercion were not abandoned, at which Lord North expressed much surprise. The tale of his obtaining the Hutchinson letters, though long believed and often repeated, has been disproved. After his return he entered into business, removed to Edenton, N. C., and during the war served as an army surgeon, and was sent to the legislature. He was a member of Congress 1782-5 and 1787-8, and of the Constitutional Convention in 1787: at home he pleaded the cause of the Constitution, and bore a part in bringing North Carolina into the federal Union. In 1793 he removed to New York, where he attained a conspicuous place as a citizen and scholar. He contributed to the *American Museum* and to the *Transactions* of several learned bodies, wrote upon comets and canals, and delivered an address before the New York Historical Society in 1810 on *The Benefits of Civil History*. His *Observations on Climate* (1811) had a patriotic object—to defend America from the aspersions of certain foreigners in this respect—and received praise from Jefferson. His *History of North Carolina* (2 vols., 1812) added less to his reputation. He died in New York, May 22, 1819. A *Memoir* of him by Dr. Hosack is preserved in the *Collections* of the New York Historical Society.

WILSON, DANIEL, Canadian scientist and archaeologist, was born in Edinburgh, Scotland, in 1816. After a full course of study in its High School and University, he went to London to engage in literary work, but soon returned to his native city. Here his devotion to archaeology procured for him the appointment of secretary of the Scottish Antiquarian Society. In 1843 he removed to Canada, where he was made professor of history and English literature in University College, Toronto. In Canada Dr. Wilson found a wide field for his favorite researches, while he also devoted himself assiduously to his academic duties. In 1881 he was chosen to be executive head of the college. His first publication was *Memorials of Edinburgh in the Olden Time* (2 vols., 1847), and, after an interval of thirty years, he produced a similar work, *Reminiscences of Old Edinburgh* (1878). His more ambitious work, *The Archaeology and Prehistoric Annals of Scotland* (1851; 2d ed., 1863), won the praise of Hallam as the most scientific treatment of the archaeological evidences of primitive history ever written. Yet this work was only preparatory to his greater achievement, *Prehistoric Man: Researches into the Origin of Civilization in the Old and the New Worlds* (1863). Its later editions have been considerably rewritten, but it still stands conspicuous not only for scientific value but for grace of literary style. Besides these archaeological works, Dr. Wilson has published *Chatterton: a Biographical Sketch* (1869); *Caliban, the Missing Link* (1873), and *Spring Wild Flowers*, a volume of verse. He has also contributed to the *Proceedings* of antiquarian, anthropological, and other scientific societies. The Marquis of Lorne, in instituting the Royal Society of Canada, nominated Dr. Wilson its vice-president. To the ninth edition of the ENCYCLOPEDIA BRITANNICA he has contributed not only the articles on "Canada" and "Toronto," but even that on "Edinburgh," besides biographical notices of "Ferguson" and "Chatterton." Dr. Wilson still lives in the city of his adoption and discharges the duties of his professorship.

WILSON, JAMES (1742-1798), signer of the Declaration of Independence, was born near St. Andrew's, Scotland, and passed from the University of that place to those of Glasgow and Edinburgh. Having finished his studies, he crossed the sea about 1763, and taught for a time in the college at Philadelphia. He and William White, afterwards bishop, became friends, and wrote in company some essays called *The Visitant* (1767-9). After studying law under Dickinson (q. v.),

and practising for a few years at Carlisle and elsewhere, he returned to Philadelphia, and soon attained very high rank in his profession. His pamphlet on *The Authority of the British Parliament* (1774) was much praised. By this time he was a colonel of militia and member of the convention of the province. Sent in 1775 to the Continental Congress, he won repute as a scholar and debater, but did not favor independence. In February, 1776, he sought to open the ports, and offered an address to the country, which, being highly conservative in substance and spirit, met with no favor, and was not even voted on. He continued to oppose all measures of separation until the will of his constituents was declared for independence; then, July 4, he signed the Declaration with his colleagues. In the same month he proposed a tax upon slaves. The next year he was made a commissioner to treat with Indiana. He defended certain Tories and merchants who refused to lower their prices to a scale proposed in popular resolutions, and by these and similar acts incurred much odium. A mob attacked his house with cannon Oct. 4, 1779; he and his friends defended it; the City Troop came to his aid, and blood was shed. He acted as advocate-general of France in the United States 1779-81, and continued to give advice for some time after; the post was more laborious and honorable than lucrative. But his gains at the bar, of which he was long the acknowledged head in his city and State, were large. He was a director of the Bank of North America from 1781, and its counsel 1785; agent for his State in 1782 in the controversy with Connecticut concerning the Wyoming tract on the Susquehanna; again a leading member in Congress in 1782 and 1786. In the Convention of 1787 he was "the best-read lawyer," and chairman of the committee which reported the draft of a constitution, August 6. His services here and afterward were perhaps more illustrious than in Congress. At the State Convention which followed he lauded the Constitution as "the best form of government ever offered to the world," and in the ceremonies which celebrated its adoption, delivered at the State House, July 4, 1788, a weighty and memorable oration. Yet as a member of a committee to harmonize the State constitution with that of the United States, he took the other side in objecting to the choice of senators by electors. Washington appointed him in October, 1789, one of the first judges of the U. S. Supreme Court. This post he retained till his death, though his talents were thought to shine more brilliantly at the bar than on the bench. One of his decisions, in a case concerning Georgia, asserted the sovereignty of the nation; in this Chief-Justice Jay and two others concurred. He received in 1790 the first appointment as professor of law at the City College, which was united with the University of Pennsylvania in 1792. Here he delivered but three courses of lectures. Appointed in March, 1791, to revise and digest the laws of Pennsylvania, he submitted in August an elaborate plan. The Senate did not concur, and he carried on the task for his own satisfaction, without authority or compensation. His later practice was chiefly in the admiralty courts. Large as were his gains, they were swallowed by the land speculations then so disastrously rife; he became involved, and to avoid arrest for debt, exchanged circuits with a Southern colleague. He died at Edenton, N. C., Aug. 28, 1798, of strangury, according to the older accounts. Prof. McMaster goes so far as to say that he "died a broken-hearted fugitive from justice." His *Works*, including his law-lectures, were edited by his son, Rev. Bird Wilson (3 vols., 1803-4).

(F. M. B.)

WINCHELL, ALEXANDER, geologist, was born at North East, Dutchess co., N. Y., Dec. 31, 1824. While still young he evinced a strong inclination towards what has been the pursuit of his life, and began teaching at the early age of 15. After several years thus engaged, he entered Wesleyan University, Middletown, Conn., from which he graduated in 1847.

During the two or three succeeding years he taught the natural sciences in New York seminaries, engaged in the study of botany, and in 1849 married Miss Julia Frances Lines, of Utica, N. Y. In 1850 he removed to Alabama, where for several years he had charge of institutions of learning, and continued actively his natural history studies, sending a valuable collection of plants, animals, and fossils to the Smithsonian Institution in 1853. In the same year, on the recommendation of Prof. Louis Agassiz, he was nominated professor of physics and civil engineering in the University of Michigan, and early in 1854 entered upon his duties in this institution, with which he has been so long connected. In 1855 he was made professor of geology, zoölogy, and botany, which chair he continued to fill until June, 1873.

During this period he performed other labors of importance. In 1859 he served as President of the State Teachers' Association, and edited and published the *Michigan Journal of Education*, and about the same time began that system of popular writing and lecturing on science which he has diligently kept up since. From 1859 to 1861 he occupied the position of State geologist of Michigan, and again from 1869 to 1871, acting also as director of the geological survey of Minnesota in 1870. The results of his labors in this field of duty were embodied in several volumes of reports of the surveys. They include *The Grand Traverse Region of Michigan*; a *Geological Map of Michigan*; and an *Official Geological Survey of the Salt Lands of Minnesota*, with numerous papers in scientific journals. His study of the zoölogical and paleontological material collected during the survey yielded seven new genera and 304 new species of animals, mostly fossil. During this period also he filled from 1866 to 1869 a chair in the Kentucky University similar to that occupied in the University of Michigan.

In 1872 he accepted the position of chancellor of Syracuse University, N. Y., but resigned in 1874, and during several successive years held the chair of geology and zoölogy in that institution, while lecturing on the same subject at Vanderbilt University, Tenn. In 1879 he was recalled to the University of Michigan and assumed the chair of geology and paleontology, which he still holds.

While thus actively engaged as a geologist and educator, Prof. Winchell has been an industrious writer, and, in addition to the works named, has produced a considerable number of works of popular science. His first production of this kind was *Sketches of Creation* (1870). About the same time appeared a work on *The Genealogy of the Winchell Family in America*. Later works comprise *Geology of the Stars* (1872); *The Doctrine of Evolution* (1874); *Reconciliation of Science and Religion* (1877); *Pseudomites* (1880); *Sparks from a Geologist's Hammer* (1881); *World Life* (1883); *Geological Excursions* (1884); *Geological Studies* (1886), and *Shall we Teach Geology?* (1889). In addition to the foregoing, *Walks and Talks in the Geological Field* (1886) was written for the "Chautauqua Literary and Scientific Circle."

Within recent years Prof. Winchell has been engaged on geological work under the auspices of the U. S. Geological Survey, and in the summers of 1886 and 1887 served on the Minnesota Geological Survey in the region north of Lake Superior, publishing extended reports of each year's explorations. In 1888 he was chairman of a committee to organize the American Geological Society, and became vice-president of the society when organized. Early in 1888, he, with six others, established the *American Geologist*, to whose pages he has since been an active contributor. In 1867 he received the degree of Doctor of Laws from the Wesleyan University. He has been a member of the American Association for the Advancement of Science since 1850, and is a corresponding or honorary member of most of the scientific societies in the United States and of many in Europe.

Prof. Winchell occupies a high rank among American scientists. His long continued services as an educator in advanced institutions of learning, his labors in the field as a practical geologist, the valuable reports in which his geological observations are embodied, the collections he has made and the new genera and species described, and his many works devoted to the popularization of science, constitute a vast amount of important labors, indicative of unusual industry in the field of scientific study. His works of popular science are written in a clear and interesting manner which goes far to explain their popularity, while at the same time they are of a fulness and accuracy and possess an abundant reference to authorities which are indicative of the carefulness and very wide reading of the author, and make them of value to learned as well as unlearned readers. He is a Christian scientist. While a believer in the theory of evolution, he does not consider that this is irreconcilable with the teachings of Christianity. He has done important work in the direction of harmonizing the doctrines of religion and science. Prof. Winchell contributed to this work the article on DARWINISM. (C. M.)

WINDMILLS. See AGRICULTURE, Chap. III.

WINEBRENNER, JOHN. See CHURCH OF GOD.

WINES, ENOCH COBB (1806-1879), prison reformer, was born at Hanover, N. J., Feb. 17, 1806. After graduating at Middlebury College, Vt., 1827, and teaching for two years in Vermont, Virginia, and Washington, he was attached to the U. S. ship Constitution, 1829-31, and described the Mediterranean and other experiences in *Two Years and a Half in the American Navy*, 1832. He taught in a Princeton school, 1833-38, in the Philadelphia high-school, 1838-44, and at Burlington, N. J., 1844-48. After entering the Congregational ministry 1849 and holding charges in Vermont and Long Island, he was appointed classical professor in Washington College, Pa., 1853, and was president of the City University of St. Louis, 1859. His specialty was not discovered till 1862, when he became secretary of the New York Prison Association, and gave himself to its line of work. In 1870 he was transferred to a similar position in the National Prison Association, then organized at Cincinnati, chiefly by his means. In 1871 he was sent to Europe by the U. S. government to bring about an international penitentiary congress. At its meeting in London, July 4, 1872, twenty-six countries were represented, and Wines was made chairman of a permanent international committee, which after several meetings called together a second congress at Stockholm in 1877. Of this he was as before the directing and inspiring mind. His work in these later years is shown by his various reports, and in *The State Prisons and Child-saving Institutions throughout the World* (1880), which he did not live to see in print. Of his earlier books the more notable are *How shall I Govern My School?* (1838) and *Commentaries on the Laws of the Ancient Hebrews* (1853); the latter received much praise. He died at Cambridge, Mass., Dec. 10, 1879. His work in gathering the statistics of prisons, etc., has been carried on by his son, F. H. Wines.

WINLOCK, JOSEPH (1826-1875), astronomer and mathematician, was born in Shelby county, Ky., Feb. 6, 1826, and died suddenly in Cambridge, Mass., June 11, 1875. His father, Fielding Winlock, was a lawyer, and his grandfather, Gen. Joseph Winlock, a Virginian by birth, was one of the early settlers of Kentucky, and for some years a member of the State Senate. The latter having joined the American army at the outbreak of the Revolutionary war, when he was only eighteen years old, was promoted to the rank of ensign, lieutenant, and captain, and in the war of 1812 held the commission of brigadier-general. His grandson was graduated with distinction from Shelby College in 1845, and was immediately appointed professor of mathematics and astronomy in that institution. He held this position till 1852, when he went to

Cambridge to take part in the computations for the newly established *American Ephemeris and Nautical Almanac*, and remained in this service till 1856, when he was appointed professor of mathematics in the U. S. Navy. He was first assigned to duty at the Naval Observatory in Washington, but in September, 1856, was placed in charge of the *Nautical Almanac* office, in Cambridge. In 1859 he was ordered to the Naval Academy, Annapolis, as head of the department of mathematics. At the outbreak of the war in 1861 he was again appointed superintendent of the *Nautical Almanac* and held this post till he resigned from the navy in 1866 to accept the position of Phillips professor of astronomy in Harvard College and director of the observatory. Up to this time his work had been almost entirely in theoretical astronomy and in class instruction, but upon assuming the directorship of the observatory, he devoted himself to practical astronomy, to the improvement of the instrumental equipment of the observatory, and to the establishment of its time-service upon a very effective and simple plan. In the new meridian circle mounted at the observatory in 1870, he introduced a number of modifications which have been generally adopted in the large meridian circles constructed since that time. In 1869 Prof. Winlock was chief of the party organized under the U. S. Coast Survey (of which he was consulting astronomer), for observing the eclipse of the sun of Aug. 7, and he was here the first to obtain a direct photograph of the corona. In 1870 he had charge of a similar party to observe the solar eclipse of Dec. 22 at Xerez de la Frontera in Spain, numbering among his colleagues Profs. Young, Langley, and Pickering. While preparing for this second eclipse he devised the form of "photoheliograph" (see TELESCOPE) used by the American parties in observing the transits of Venus in 1874 and 1882. In August, 1874, he was appointed by Pres. Grant chief of the commission established by act of Congress for the purpose of inquiring into the causes of steam-boiler explosions, and his preparations for preliminary experiments were nearly completed at the time of his death.

Professor Winlock wrote but little. His published work is found chiefly in the *Annals of the Harvard Observatory* and among the official publications of the Almanac office and the eclipse *Reports of the Coast Survey*. He was a Fellow of the American Association for the Advancement of Science and of the American Academy of Arts and Sciences, a member of the Astronomische Gesellschaft, and a corporate member of the National Academy of Sciences. (w. c. w.)

WINSOR, JUSTIN, librarian, was born in Boston, Jan. 2, 1831, and received his education at Harvard and Heidelberg. He was superintendent of the Boston Public Library during 1868-77, and then became librarian of the Harvard University Library. From 1876 to 1886 he was president of the American Library Association, being the first to hold that office. Widely known as a librarian, he has also gained an enviable position as an author. His writings include *History of Duxbury, Mass.* (1849); *Reader's Hand Book of the American Revolution, 1761-83* (Boston, 1880); *Was Shakespeare Shapleigh?* (Boston, 1887); and various pamphlets on historical subjects. He has also edited the *Memorial History of Boston* (4 vols., 1880-81), the valuable *Narrative and Critical History of America*, the *Harvard University Bulletin* (since 1877); *Bibliographical Contributions*, for which he has himself furnished several valuable bibliographies of Ptolemy's Geography, J. O. Halliwell Phillips, etc.; and the *Record of the Commemoration 5-8 Nov., 1886, on the 250th Anniversary of the Founding of Harvard College* (Cambridge, 1887). He received the degree of LL. D. from the University of Michigan.

(F. L. W.)

WIRE. See ROLLING-MILLS.

WISE, HENRY ALEXANDER (1806-1876), Governor of Virginia, was born at Drummondtown, Va.,

Dec. 3, 1806. He graduated at Washington College, Pa., 1825, was admitted to the bar in 1828, and after a year or two of practice at Nashville, returned to Virginia in 1830. In the national Democratic convention of 1832 he supported the nomination of Jackson, but opposed that of Van Buren. Steering a middle course, he approved neither the doctrines of nullification nor the stern repression of them by the government. In Congress, 1833-44, he won considerable reputation as a speaker, opposed Jackson's removal of the deposits, favored Clay's nomination in 1840, and urged that of Tyler as Vice-President. After Tyler's accession to the Presidency, Wise was one of his chief friends and counsellors. Named in 1843 as minister to France, but not confirmed by the Senate, he was appointed to Brazil in 1844, and remained there three years. He was a member of the Virginia Constitutional Convention of 1850. In 1855 he was an Anti-Know-Nothing candidate for Governor, and was elected. His four years in this office, 1856-60, cover a period of great historical importance. In September, 1856, he called upon the governors of other Southern States to meet in October for consultation as to the steps to be taken in the event of Fremont's election. In 1858, as a Douglas Democrat, he sketched and attacked, in a letter to W. Sargent, the scheme of the disunionist intrigues, as carried out two years later. In February, 1861, he urged pacific measures of compromise; these failing, he soon went with his State. His career as a Confederate brigadier was a succession of disasters, ending with the capture of his forces and the death of a son at Roanoke Island, Feb. 7, 1862. His later years were spent in the practice of law at Richmond. He died Sept. 12, 1876.

WITHERSPOON, JOHN (1722-1794), president of Princeton College and signer of the Declaration of Independence, was the son of a Scotch minister at Yester, near Edinburgh, and descended on his mother's side from John Knox, whose vigor, tenacity, and combativeness he in some degree inherited. Born Feb. 5, 1722, he was educated at the University of Edinburgh, licensed to preach in 1743, and ordained minister of Both 1745. The next year he witnessed the battle of Falkirk, was arrested with other spectators by the victors, and imprisoned in Doune Castle. His earliest honors were won in the controversies of the time, wherein he warmly espoused the stricter side against Robertson and the Moderates. His first book, *Ecclesiastical Characteristics* (1753), an anonymous satire, made much stir, and was followed by a *Serious Apology*, which bore his name. An *Essay on Justification* (1756) retains fame among treatises of the high Calvinistic order. An *Inquiry into the Nature and Effects of the Stage* (1757) was aimed at Home and his tragedy of *Douglas*; the guilty author soon left the ministry. The Moderate faction in Presbytery opposed Witherspoon's preferment to the Low Church at Paisley, but he was installed in January, 1757, and shortly became moderator of the Synod of Glasgow and Ayr. Here he was prosecuted and fined for preaching against certain sinners by name. His literary career, arrested for a time, was resumed by the publication in London of his *Essays* (3 vols., 1764). He now received the degree of D. D. from Aberdeen, and invitations from Dublin, Dundee, and Rotterdam. These he declined, as also a first call in November, 1766, from the College of New Jersey (*q. v.*), but when this call was renewed he bade farewell to Scotland in the spring of 1768 in a volume of *Practical Discourses*. He was inaugurated as president at Princeton College Aug. 17, and began an active and fruitful administration, introducing lectures—then a new experiment in American colleges—and the study of French and Hebrew. The latter he taught himself, besides divinity, moral philosophy, and rhetoric; in addition to all this he was pastor and preacher to the town. These labors did not prevent his travelling in New England in search of funds, and seeking them in Virginia and

South Carolina, and even Jamaica, the hearts of whose inhabitants he strove to win by a published *Address*. He obtained books and apparatus, with an orrery said to be the first made by Rittenhouse. He promptly took a leading place in Presbyterian councils, and had a hand in training many of the chief ministers and laymen of that church.

Dr. Witherspoon's expansive energies found even a larger field in the American struggle for independence, in which he was as warm as any; he said he had "become an American the moment he landed." His fast-day sermon, May 17, 1776, on the *Domination of Providence over the Passions of Men*, was dedicated to John Hancock as president of the Continental Congress, and reprinted with notes in Glasgow to show the wickedness of rebels. The war, which closed the college for a time, enabled him to devote himself to the service of the State. He was a member of the New Jersey convention called to frame a constitution for the State, and of its first Congress, which he opened with prayer. Here his gift of sarcasm was exercised upon William Franklin, son of Benjamin and royalist governor, who when arrested by the Congress strove to treat it with supercilious contempt. Witherspoon was sent to the Continental Congress June 21, and almost his first act in Philadelphia was to sign the Declaration. "The Colonies," he said, "were not only ripe for independence, but rotting for want of it." His patriotism was as solid and consistent as it was ready and outspoken. Except in 1780, when he made an effort to revive the college, he sat in Congress till November, 1782, always in clerical attire, and accounting himself "God's minister both in a sacred and in a civil sense." Already noted as a theologian, he took equal rank as a civilian, drew up many of the papers of Congress, and did his full share of work in its committees and on the floor. He was a member of the Board of War in 1777, and in February, 1781, proposed to give Congress power to regulate trade. He supported the financial measures of Robert Morris, and opposed paper issues after the second; his *Essay on Money* had solid value. His last work was *The Druid* (1781). Few civilians of the revolutionary period occupied a more prominent place in the public eye; of all the leaders of that time, after Washington, he was thought to have the most impressive presence. His important work seemed to be ended with the war. Against the advice of Franklin and Jay, he unwisely undertook in 1783-84 to solicit aid for the college in Great Britain, where popular irritation against America made the attempt useless. He yielded to the mania for land speculation, and had trouble thereby. At the age of 69 he married a lady of 23. The chief duties at Princeton in these later years were assumed by his son-in-law, the vice-president, for Dr. Witherspoon was afflicted by failing health and sight. He died at his house, "Tusculum," near Princeton, Nov. 15, 1794. His *Works* were collected in 4 vols., N. Y., 1800-1 (reprinted in 3 vols., Phila., 1803, and in 9 vols., Edinburgh, 1804). A *Life* of him by Dr. Ashbel Green remains in MS. in the library of the N. J. Historical Society. His statue was unveiled in Fairmount Park, Philadelphia, Oct. 20, 1876; the *Proceedings and Addresses* on that occasion were published in 1877.

WOLSELEY, SIR GARNET JOSEPH, VISCOUNT, an eminent British general, son of a major of the same name, was born at Golden Bridge House, County Dublin, Ireland, June 4, 1833. Educated at a private school and by tutors at home he early showed a fondness for military studies, especially engineering. He entered the army on March 12, 1852, as ensign, and went to Burmah, arriving in March, 1853. He led an attack on the works of the insurgent Mynbtoon, was dangerously wounded, and lay six months in a critical condition. In the Crimean war he arrived before Sebastopol Dec. 5, 1854, and was under fire the next day; was actively engaged in repulsing the Russian sorties, and was posted at the right in the attack of Dec.

30. He soon volunteered as an assistant engineer, was made a captain in January, 1855, took a prominent part in the siege, serving often in the trenches, and receiving several wounds, one of which gave him trouble years after. On Dec. 30 he lost an eye and was disabled by numerous wounds, through a round shot striking a gabion close to him. Recovering he was appointed on the staff of the quartermaster-general. Of twelve officers in three messes he was the only one not killed or sent home wounded. He remained in the Crimea till the last soldier had left it. After brief service at Aldershot he was sent to India and wrecked in the *Transit*, July 10, 1857, on the island of Banca. He marched under Sir Colin Campbell to the relief of Lucknow, commanded the storming party which carried the mess-house and drove the enemy from the Motu Maheel palace, took part in the later actions with the rebels, and had charge of the quartermaster-general's department of Sir Hope Grant's division during the operations in Oude and on the Nepaul frontier. Made lieutenant-colonel in April, 1859, he went to China with the same commander, reaching Hong-Kong March 13, 1860, and took part in the expedition to the island of Chusan, which surrendered. In June he went with Grant to the north of China, and in the movement toward Peking he had charge of the topographical department, surveying the country in advance of the troops, carrying his life in his hand and twice narrowly escaping capture. He witnessed the sacking of the Summer Palace and the surrender of Peking, Oct. 15. After the embarkation of the troops he made a trip to Japan, went on a confidential mission to Nankin to inquire into the condition and prospects of the Taeping rebels, and reached England in May, 1861. He sailed in December as assistant quartermaster-general to an army of 10,000 ordered to Canada. Disregarding the orders of his government he visited in August the Confederate armies in Virginia, meeting Lee and Jackson. The succeeding years were uneventful; he became colonel in 1865. The breaking out of an old Crimean wound in the leg sent him back to England, whence he returned to command a camp of exercise in Canada, and took the field against the Fenian invasion near Niagara, 1866. In 1870 he commanded the expedition which put down Riel's rebellion on the Red River. Leaving Toronto May 21 with 1200 men, he made a road from Thunder Bay, on Lake Superior, took Fort Garry in August, restored order, installed a new governor of Manitoba, started eastward Sept. 10, and returned to England to be knighted and placed on half-pay.

Six months later he was appointed assistant adjutant-general of the Horse Guards, and was a member of Cardwell's commission for the reorganization of the army. In August, 1873, he was ordered to the Gold Coast of Africa as governor and major-general to conduct the Ashantee war. Embarking at Liverpool Sept. 12 he arrived at Cape Coast Castle Oct. 2 with 27 selected officers, and twelve days later attacked Essaman with success. After a dangerous attack of fever he received reinforcements, instructed them in bush-fighting, and marched into the interior. With 1500 English and 500 natives he defeated King Coffee Caluelli at Amsapel, Jan. 31, 1874. He entered Coomassie Feb. 4, and burned and left it three days later. The king now submitted, and the treaty of Pommanah was concluded, Feb. 13. Sir Garnet sailed for England March 4, having rapidly and successfully finished this war at a cost of £900,000. At home he received the thanks of Parliament, the permanent rank of major-general, a grant of £25,000, the ribbon of the Bath, and various other honors.

He was presently made inspector-general of the auxiliary forces, and sent, February, 1875, to Natal to reform the administration and secure the defences of the colony. After acting as governor five months, instituting many reforms, he returned to England in October and assumed his duties at the war office. In

November, 1876, he accepted a seat in the Council of India. While war with Russia threatened, 1877-78, he was chief of staff to Lord Napier of Magdala, who was in command of the expeditionary army. Cyprus having been ceded by Turkey to Great Britain, he sailed July 15, 1878, as high commissioner and commander-in-chief of that island, where he reformed the administration. He predicted the Zulu war, and in June, 1879, was sent to South Africa as governor and high commissioner of Natal and the Transvaal to reorganize Zulu affairs. The natives had been subdued at Ulundi before his arrival, but he settled the country by dividing it under a number of petty chiefs. Returning to England May, 1880, he was quartermaster-general at army head-quarters till April, 1882, when he succeeded Sir Charles Elliot as adjutant-general.

Placed in command of the expeditionary force sent to Egypt in 1882 to crush Arabi, he landed at Alexandria on Aug. 15, stormed Arabi's lines at Tel-el-Kebir Sept. 13, received his surrender, and finished the campaign without much loss, leaving Egypt Oct. 14. He again received the thanks of Parliament, was gazetted Baron Wolseley of Cairo and of Wolseley in county Stafford, and raised to the rank of general. In 1883 he received the degree of D. C. L. from Oxford, and that of LL.D. from Cambridge and Dublin. In 1884 he was again sent to Egypt as commander-in-chief to direct the expedition for the relief of Khartoum and Gen. Gordon. This was a task greater than had previously been laid upon him, and perhaps beyond human skill; at any rate his previous successes were not now repeated. Leaving England Aug. 30 he went up the Nile, and by Dec. 31 had a large force at Korti. Sir H. Stewart was sent across the desert to Metemuch, which he found too strong to be attacked. Sir Charles Wilson went up the Nile by steamer, but learned of the fall of Khartoum and the death of Gordon, Jan. 28, 1885. This disaster changed the aspect of affairs. Lord Wolseley, feeling that Khartoum should be retaken, but unwilling to exceed his limits of responsibility, sent to England for instructions, and received orders to retire upon Korti. Gen. Barle had meantime advanced up the Nile, but was killed, and Col. Brackenbury withdrew his troops. By the end of May the British forces had retired to the frontier of Upper Egypt. This somewhat inglorious campaign appeared to demonstrate the inability of European armies to cope with a large and organized force of Arabs on their native sands of the remote Soudan. The Mahdi has never been overthrown, and Gordon is still unavenged. The commander, though much criticised, was sustained by the government and by general opinion. Returning home he was a third time thanked by Parliament, and made K. P. and Viscount Wolseley of Wolseley, county Stafford.

He is still adjutant-general to the forces, and represents the modern school of the British army. His many accomplishments and honors afford a natural mark for detraction; he has been sneered at as a skillful concocter of despatches, a courtier, politician, and carpet-knight. To such accusations the facts of his life are a sufficient answer. He has published *A Narrative of the War in China in 1860* (1862); *Soldier's Pocket Book for Field Service* (1869), which has been called "invaluable" and has reached a fourth edition (1882); *System of Field Manœuvres, in Essays for the Wellington Prize* (1872); *Field Pocket-Book for the Auxiliary Forces* (1873); and various contributions to periodicals, among them *France as a Military Power in 1870 and 1878* in the *Nineteenth Century* for January, 1878. His *Life* was written by Charles Rathbone Low (1878).

WOMEN, LAW RELATING TO. In the United

States the national government, being a government of ceded powers, has no power by legislation to determine the status of the citizens of the several States or of its own citizens resident within the

States, or to make laws governing the rights of real or personal property situate within the States; hence there can be but little national legislation in regard to women. Each State makes laws governing the status of its own citizens and of the United States citizens resident therein, also of property located within its borders, the only restrictions upon State legislation upon this or any other subject exclusively within the jurisdiction of the State governments being that it shall not be in conflict with the United States Constitution and the laws made in pursuance thereof. From this peculiar construction of the United States government the laws in regard to women, their personal and property rights, are not uniform throughout the United States.

1. *Law of the United States.*—Amendment XIV., Section 1, of the United States Constitution declares that "All persons born or naturalized in the United States and subject to the jurisdiction thereof are citizens of the United States and of the State in which they reside. No State shall make or enforce any law which shall abridge the privileges or immunities of citizens of the United States; nor shall any State deprive any person of life, liberty, or property without due process of law; nor deny to any person within its jurisdiction the equal protection of the laws." Amendment XV. declares that "The right of citizens of the United States to vote shall not be denied or abridged by the United States or any State on account of race, color, or previous condition of servitude," and Section 2 of Amendment IV. provides that "The citizens of each State shall be entitled to all privileges and immunities of citizens in the several States."

Under these provisions of the United States Constitution no State can, by its legislation or by constitutional amendment, deprive women resident within its borders, either native-born or naturalized by the naturalization laws of the United States, of citizenship of the United States and of the individual State in which they reside nor of the "essentials" of such citizenship.

But what are the essentials and rights of citizenship has been the subject of judicial construction in both the Federal and State courts, and notwithstanding the express recognition of the "right to vote" as a right of the United States citizens, given in Amendment XV. of the national Constitution, it has been held that although all United States citizens are capable of becoming voters, the right to vote is not a right, immunity or essential of citizenship, and that the States may so regulate its exercise as to determine what class of inhabitants may vote, and may deny this right on account of sex and upon all grounds except race, color, or previous condition of servitude, an anomalous construction of the fundamental law of a government whose existence depends upon the exercise of the elective franchise by its citizens.

A similar construction has been given as to the civil rights apparently guaranteed to all citizens of the United States by these constitutional provisions; hence in general terms it may be stated that the political and civil rights of women citizens of the United States are determined not by the Constitution and law of the United States, but by the constitution and law of the State in which they reside, and are indices of the progressive intelligence of the States. The subject of naturalization being exclusively within the jurisdiction of the general government, the naturalization laws are national and provide for the naturalization of women aliens, either upon direct application or as wives and children of naturalized citizens; also as children of native-born citizens resident abroad, that is, outside of the jurisdiction of the United States, at the time of their birth.

As citizens of the United States women may be commissioned by the general government as post-mistresses, U. S. marshals, captains of steamboats, surgeons in the army, nurses and matrons in governmental

See Vol. XXIV, p. 633 (p. 673 Am. Rep.).

hospitals, clerks in the several departments of government, and by special act of Congress women may be commissioned as attorneys-at-law of the Supreme Court of the United States. Her right to a commission as an attorney-at-law of the Circuit and District Courts of the United States depends upon the provisions of the law of the State in which such court holds its sessions. Women citizens of the United States may also pre-empt lands under the laws of the general government. They are counted in the basis of representation, both in the State and national governments, and are subject to the general laws governing taxation; are capable of committing treason and for treasonable acts are held responsible to the general government.

2. *The State Law.*—The characteristic difference in the personal rights of men and women in the United States consists in the enjoyment of political rights by the former. In every State and Territory of the United States every man not convicted of an ignominious crime is a voter or capable of becoming a voter, clothed with all political rights, and eligible to the highest office in the government, if he be native-born, although in many instances exempt from many of the corresponding political duties of citizenship, while women are very generally deprived of political rights. From this deprivation of political rights arise all the legal disabilities of women in the United States which are not incident to the marriage relation under the common law of England. Each State has the power to extend the right of suffrage to its women citizens, either by constitutional amendment or by virtue of a constitutional provision already existing—as in Wisconsin and Colorado—by a majority vote of its qualified electors at any general election; also by a three-fourths vote of the States the national Constitution may be amended so as to secure to women throughout the United States the right to vote. Strenuous and continued efforts have been made to secure these constitutional amendments, and it is believed that soon women in the United States will be very generally clothed with political power.

Already in the Territories of Wyoming, Washington, and Utah women vote, serve upon juries, and are eligible to office; in short, are clothed equally with men with full political rights, and are subject to the corresponding political duties of citizenship.

In Kansas women have equal suffrage upon all municipal questions and at all municipal elections, and are eligible to all municipal offices—absolutely filling the office of mayor of the municipality in several instances, but may not vote at Presidential and Congressional elections.

Since the adoption of Amendments XIV. and XV. to the national Constitution, the right of women citizens of the United States to vote at Presidential and Congressional elections has been tested in New York, Illinois, Missouri, California, Connecticut, and Pennsylvania. In Pennsylvania, in 1872, the right of women to vote at the State elections under the word "freemen" in the State Constitution describing the qualifications of voters in that State was claimed and resulted in a change in the State Constitution, by which the words "male citizens" were substituted for the word "freemen," thus confining suffrage to men.

Pennsylvania recognizes the right of women to direct representation upon the public school question, by making her eligible to an elective office upon the school board, thus indirectly recognizing the correlative right of suffrage. At the present time more than half of the States recognize the right of married and unmarried women to the school franchise; noted among which in the East are Massachusetts and New York.

In several instances married women have been called upon to serve upon the school board—always an elective office—and in one instance to fill the office of State school superintendent.

In a number of the States strenuous efforts have

been made by those opposed to woman suffrage to have the right to vote upon the question of "license or prohibition" generally extended to woman. No State has as yet extended equal suffrage to women, nor has any woman yet been called upon to fill the higher political and judicial offices of the State or nation. England, accustomed to women occupying the highest office in the kingdom, more easily extends the franchise, subject to a property qualification, to unmarried women and widows.

Professional Rights.—The civil right of choosing one's profession or trade apparently guaranteed to all citizens by the Declaration of Rights, adopted as a constitutional provision in all of the States and in Amendment XIV. of the U. S. Constitution—has not until recently been practically recognized as a right of women in any of the States, and now but partially prevails throughout the United States.

The profession of medicine is open to women in all of the States, and thousands of women in the United States are successfully engaged in this profession. Women are admitted upon equal terms with men into the medical department of many American colleges and universities. There are also numerous medical colleges—chartered and well-endowed—for women exclusively, and medical societies, both State and national, are gradually recognizing their right as medical practitioners to become members thereof, in full fellowship.

All of the States in which the question has been raised have either by direct legislation or by a generic interpretation of the existing law recognized women's right to enter the legal profession—Pennsylvania being one of the first in which application was made, and one of the last to extend this recognition to women. In Pennsylvania a woman attorney-at-law may, as an officer and appointee of the court, serve as master and examiner in equity cases, in which office she is clothed with the power of the court to subpoena witnesses and to administer the oath, but may not be appointed by the governor as a notary public. In Connecticut, Massachusetts, New York, and generally in the Western States woman may act as notary public, United States and State commissioner of deeds, and very generally as administratrix and executrix. The University of Pennsylvania in Philadelphia, Howard University in Washington, Washington University in St. Louis, Columbia Law College of New York, also many other law colleges east and west, afford women equal opportunity with men to become qualified as legal practitioners and confer upon them the degree of Bachelor of Law. Probably not more than one hundred women in the United States are actually engaged in the legal profession.

The government neither recognizes nor denies woman's right to enter the clerical profession. The orthodox religious denominations very generally refuse to ordain her as a minister, but the Society of Friends and the most liberal religious sects give her official recognition. Women occupy high and responsible positions as educators, public and private, authors, editors, artists, and musicians, and in commercial life, and although they may receive the well-earned degree of Doctor of Medicine, Doctor of Dental Surgery, Doctor of Philosophy, Bachelor of Laws, Bachelor of Arts, Bachelor of Music, and Master of Arts—no theological school is yet open to them, and as yet they are ineligible for the degree of Doctor of Divinity.

Neither do the oldest colleges and universities admit women in all departments to a full course of instruction. Harvard, to meet the demand for their higher education, has created a department known as the Harvard Annex, in which they may study and receive a certificate of proficiency. Manual schools of training are now being established in connection with schools for girls, and normal and art schools, also business and commercial colleges very generally afford educational opportunities to women and girls.

Women and girls are generally admitted into all

trades, subject to the laws prohibiting child labor, and are very generally admitted into labor organizations, but are not found at the stock exchange. Female children may be bound out or apprenticed to learn a trade or as domestic servants by their guardians, parents, or if paupers by the town or municipal authorities.

Family Rights.—A girl generally becomes of age at twenty-one; but in some of the States, as in Vermont, she is of age at eighteen, or, as in some parts of the United States, at the time of marriage, provided the marriage takes place before she arrives at the regularly prescribed age of legal majority. She, however, arrives at the age of consent so as to be capable of committing crime at from twelve to sixteen years, and may at this age generally contract a valid marriage—although in many of the States to marry a girl who is a minor without the consent of her parents or guardians is a misdemeanor punishable with fine and imprisonment. In Louisiana marriage is a partnership in which there is community of interests. In all the other States marriage is a civil contract, regulated and controlled by the law of the State in which the parties reside, and may generally be solemnized by a clergyman or by a justice of the peace, or other civil magistrate. In New York, Pennsylvania, and some other States this contract may become completed by any sufficient words or form chosen by the parties in the present tense.

The legal disabilities of married women, arising under the common law legal merger of the wife's individuality in that of her husband, who thereby becomes the head of the house and family, obtains in some of the States so that a married woman may not make a valid contract except as to her own estate. In Ohio, New York, Georgia, Nebraska, and Wyoming, in consequence of this inability to contract, a married woman may not act as an administratrix. These disabilities are gradually being superseded by a general recognition of a reciprocity of duties and a joint tenancy in rights and responsibilities in the married relation, so that in many States married women may make contracts and enforce them by legal action; also are liable on their ante- and post-nuptial contracts.

In the Eastern States a married woman is entitled to respect and honor from her children, but generally is not entitled to their custody nor bound for their maintenance and education, unless she has a separate estate and the father is unable to support them. On becoming a widow the mother is invested with full parental authority, is bound for their support and entitled to their earnings.

In the newer Western States the more liberal law is that the father and mother have equal parental rights, duties, control, and custody of their legitimate children, and in all of the States, in case of a separation of the parents, the custody of their children is determined by the court, having reference only to the welfare of the child and the ability of the parents, which provision may be inserted, in case there is a judicial separation, in the deed of separation.

An unmarried woman has all the rights and duties of parental control of an illegitimate child, and may inherit from and transmit property by the laws of descent through said child. Female heirs in the United States are under no disability as to their intestate succession to real estate, as in England, but their right to administration is in some States postponed in favor of an older male heir.

Marriage may be dissolved by the law of the State in which the parties reside, or by the law of the State in which the husband has his domicile, or in that where the wife has acquired a legitimate residence and citizenship, and is the libellant in the case, for causes specified by the laws of the several States. But very generally desertion, cruel and barbarous treatment, wanton indignities to the person too great to be endured, adultery, imprisonment for three years, and conviction of an ignominious crime are grounds upon which to found a proceeding in divorce, subject to the

rules of practice in the State in which the action is brought. In this proceeding the husband and wife stand upon an equality, the husband being compelled to furnish the wife with counsel fees and alimony during the pendency of the suit if she has not a sufficient separate estate. A woman may not testify to any confidential communications of her husband, nor against her husband, nor the husband against his wife, unless in case of a proceeding in divorce. Neither can a wife be sued by her husband for her tort committed during coverture unless in a proceeding in the nature of a divorce.

Married women may maintain an action of slander against their husbands. They may also maintain an action against their husbands upon an ante-nuptial contract, in which the husband abrogated his marital rights under the statute law in consideration of marriage, such contract being good as between the parties.

Married women may not be arrested or imprisoned for debt in any State, but may be imprisoned for contempt of court. They are generally liable for their torts, and all women, married or single, are liable to the criminal law of the State to the full penalty of the law, even though that be death. Women may maintain an action in damages for breach of promise and for seduction in their own right.

Property Rights.—The laws governing the rights of property of married women form a large part of the laws of the several States in regard to women. There is nothing peculiar in the law governing the property rights of unmarried women and widows, except in those States in which there is a property qualification of suffrage, the rights of unmarried women and widows arising from the ownership of property are not the same as those of men.

Prior to 1848 the common law of England, as to the property rights of married women, prevailed very generally throughout the United States. In the years 1848 and 1850 several of these existing States passed a Married Woman's Property Act, securing to a married woman all legal and equitable estates owned by her at the time of her marriage or acquired by her during coverture by gift, devise, or purchase, other than from or through her husband, for her sole and separate use, to be hers absolutely, and not liable to be taken in execution for her husband's debts.

These acts very generally empowered her to dispose of her separate estate by sale, her husband giving his consent thereto and joining in the deed of conveyance, also by last will and testament (her husband having first given his written consent thereto), subject to the husband's right of curtesy, or otherwise to dispose of it according to the terms of the articles of settlement by which her separate estate was created.

These acts, designed only to protect the separate estate of the wife from execution for the husband's debts, were so construed as to give to the husband, as the natural guardian of the wife, the exclusive right of control and management, also the rents and profits of her separate estate, thus depriving her entirely of the rights of ownership—so "jealous" was the law for the "protection of the rights of the wife." These laws all failed to emancipate her person from the common law control of the husband, so as to recognize her right to her earnings after marriage, or to any interest in their joint earnings other than her dower, which, as at common law, she had in all lands possessed by the husband during coverture. Many of these older States have since so modified their laws as to give to married women absolute power to dispose of their separate estate by will, subject only to the husband's right of statute or common law curtesy, and to secure to a married woman her own earnings, either as a *feme sole* trader, or by petition filed declaring her intention to claim her earnings subsequent to the date of the petition, the effort being to gradually remove the legal disabilities of married women as to property, and to secure to them all the rights of ownership consistent

with the common law idea of marriage. The newer States erected since that period have very generally made more liberal laws, equalizing the property rights of the husband and wife in the separate estate of the other, making a statutory dower and curtesy which shall be equal, or abolishing all dower and curtesy and giving widow and widower equal rights under the intestate laws, both in their separate and joint estates; in short, recognizing the legal individuality of the wife, and giving a community of interests with equal rights of control over the property secured by their joint earnings after marriage.

Some of the States, as Mississippi, Delaware, and Indiana, have also abolished all dower and curtesy, and given instead statutory rights under the intestate laws, while Florida, West Virginia, and Louisiana have created a statutory dower of a life-interest in all of the estates of the husband and in their joint earnings. In general both the husband and wife must join in the deed of conveyance of the joint property, and of the property acquired by either before marriage; but in many of the States the husband may yet mortgage his property and the property secured by their joint earnings, such property standing in his name, without the wife joining in the deed of conveyance. Massachusetts gives all the property to the widow if there are no children, if the property does not exceed in value \$5000. Some other States make the limited value which the childless widow may take \$20,000, the surplus being divided among the relatives of the husband; but if there are no kindred of his living, then the widow may take the entire estate. Pennsylvania gives the widow and widower equal shares in the separate estates of husband and wife; if there are no children, the husband and widower possesses absolutely the joint property secured and acquired by their joint earnings after marriage, unless during the lifetime of the wife she is recognized as a business partner, while the widow, if there are no children, has one-half of the personalty absolutely, and but a life-interest in one-third of the realty, the remaining portion being given to the relatives of the husband; but in case there are no kindred of the husband living, she takes, under the intestate laws, the entire property, as does the widower, without regard to her kindred, if there are no children.

In New Jersey, Maryland, and South Carolina the common law rights of the husband and widower still prevail as to the property acquired after marriage and the separate property of the wife, while the widow takes but the common law portion in the husband's estate.

A very general provision is made for the exemption of certain property from execution for the benefit of the family, ranging from the sum of \$300 to a homestead of 160 acres of land; or if located within a town or city, a homestead of the value of \$5000, which homestead can neither be mortgaged nor sold unless the wife joins in the deed of conveyance and a separate acknowledgment is taken from her. These homestead laws are for the benefit of the wife and children. To understand the laws governing the rights of property of married women accurately it is necessary to become familiar with the statutes of each State, but in general it may be stated that the wife has the absolute control and management of her separate estate, and is entitled to receive therefrom the rents and profits, and appropriate the same to her own use, and may make valid contracts for the benefit of her own separate estate, upon which she may sue and be sued; and while the tendency is uniform and steady throughout the United States to equalize the property rights of married men and women, and while married women may very generally have the rights of ownership over their own separate earnings after marriage secured to them, the husband has generally the superior right of control and ownership of the property acquired by their joint efforts after marriage—a vestige of the common law merger of the legal individuality of the wife in that of

the husband destined soon to be relegated like its other provisions to the past. (See DIVORCE, HUSBAND AND WIFE, INTERNATIONAL LAW, etc.) (C. B. K.)

WOOD, GEORGE B. (1797–1879), physician and medical author, was born in Greenwich, Cumberland co., N. J., March 13, 1797. He began his education in New York but afterwards entered the University of Pennsylvania where he graduated in 1815, and received his degree of M. D. in 1818. In 1820 he delivered a course of lectures on chemistry, and in 1822 was appointed to the chair of chemistry in the Philadelphia College of Pharmacy, and in 1831 to that of materia medica in the same school. In 1835 he was appointed professor of chemistry and pharmacy in the University of Pennsylvania, which position he filled for 15 years, with eminent distinction. In 1850 he was transferred to the chair of the theory and practice of medicine, which he continued to fill till 1860, when he resigned and was appointed *professor emeritus*. Dr. Wood had devoted himself earnestly to the advancement of his students and had promoted the interests and enhanced the reputation of the University of Pennsylvania. He procured at great expense living specimens of exotic plants for exhibition to his students. In 1865 he endowed, in connection with the university, an auxiliary faculty of medicine consisting of five chairs: zoölogy and comparative anatomy, botany, geology and mineralogy, hygiene, medical jurisprudence and toxicology. In 1859 Dr. Wood was elected president of the American Philosophical Society. He died March 30, 1879. Besides preparing a *History of the University of Pennsylvania* (1827), Dr. Wood was author of a number of works which rank high in medical literature. Among these were *Treatise on the Practice of Medicine* (2 vols., 1847), which passed through several editions and was adopted as a text-book by the University of Edinburgh; and *A Treatise on Therapeutics and Pharmacology* (2 vols., 1856). *Pharmacopœia* (1850), prepared with the aid of Dr. Bache, was adopted by the national convention of physicians, and became the basis of the present *United States Pharmacopœia*. His *Dispensatory of the United States* (1st ed., 1833), a work thoroughly exhaustive in its description of many medical agents peculiar to the American practice, has gone through 16 editions, the later editions having been revised by his son, Dr. Horatio C. Wood, and others.

WOOL. See SHEEP.

WOOLSEY, THEODORE DWIGHT, president of Yale College, was born in New York city, Oct. 31, 1801. He graduated at Yale in 1820, studied law and theology at Princeton, and was a tutor at Yale for two years. He then spent three years in Germany, studying Greek at Leipzig, Bonn, and Berlin. On his return in 1831 he was made professor of Greek at Yale College. In 1843 he assisted in founding the *New Englander*, and was one of its editors. In 1846 he was chosen president of Yale College, and held this office for 25 years, during which the institution was enlarged and improved in many ways. Since 1871 he has retired from public duties, but was president of the American Company of revisers of the English New Testament from 1871 to 1881, and has been engaged in a variety of literary work. He edited as college text-books, Euripides' *Alceste* (1834); Sophocles' *Antigone* (1835) and *Electra* (1837); Æschylus' *Prometheus* (1837) and Plato's *Gorgias* (1843). He also published *Introduction to the Study of International Law* (1860; 5th ed., 1879); *Divorce and Divorce Legislation* (1869; 2d ed., 1882); *Religion of the Present and the Future* (1871); *Political Science* (2 vols., 1877); *Communism and Socialism* (1880). He has also contributed to the leading reviews.

WORM. See EARTH-WORM.

WRIGHT, SILAS (1795–1847), statesman, was born at Amherst, Mass., May 24, 1795; removed in infancy to Addison co., Vt. His father was a farmer in moderate circumstances; his ancestor had been one of the

first settlers of Springfield and Northampton. He graduated at Middlebury College, Vt., 1815, and after admission to the bar in 1819 settled at Canton, St. Lawrence co. Here he became an active member and officer of militia, and rapidly rose to prominence in State affairs, opposing Clinton and espousing the cause of Van Buren. He was sent to the State Senate in 1823, and to Congress in 1827, where he helped to frame the tariff of 1828, which he afterwards considered "a great error." Re-elected 1829 his seat was disputed, and he resigned it to succeed Marcy as comptroller of New York. This post he held four years, and during that time was a member of the Democratic State and national conventions. He was sent to the U. S. Senate 1833 for an unexpired term, and re-elected 1837 and 1843. In this body he won a high reputation and the compliments of Webster. Benton entitled him "the Cato of the Senate." He supported Pres. Jackson's measures, opposed the U. S. Bank, and voted for Clay's compromise bill. He was a delegate to the convention which nominated his friend, Van Buren, and strove to prepare the public mind for the independent treasury plan. The bill, after three failures, was passed July 1, 1840. He favored Van Buren's bankrupt bill, and labored for his re-election in 1840; supported the tariff bill of 1842, and the bank vetoes of Tyler, but opposed the other measures of that President. On the slavery question he occupied a middle ground, favorable neither to the meddling with the institution as it stood nor to the extension of its area; he resisted the extreme proposals of Calhoun, and approved measures looking towards abolition of slavery in the District of Columbia. A speech at Canton, July 4, 1839, promulgated his opinions on this topic. He declined the Chief-Justiceship, offered by Tyler in 1844, and in that year he defeated Fillmore in the contest for the governorship of New York, and resigned his seat in the Senate. This, as the issue proved, was a mistake, for he was better fitted to the national arena than to a smaller one, and to a legislative than to an executive office. Long practice had made him more familiar with measures than with men, a statesman rather than a politician. His term was troubled by the agitations of the Anti-renters and outrages of the "Indians;" these he suppressed with a strong hand, putting down an insurrection in Delaware co., and declining to pardon persons sentenced to terms of imprisonment, though he advised the mitigation of future laws by abolishing distress for rent, and other measures to modify a system which had become oppressive. His party was then divided into "Hunkers" and "Barnburners" (*q. v.*); he would lead neither, but followed a middle course, first opposing revision of the State constitution and then approving the bill for a convention after it had passed. He was renominated and defeated in 1846, and died at Canton, Aug. 27, 1847. In manners he was always a plain countryman, and this failure at home may have gone to his heart. See his *Life* by J. S. Jenkins (1847) and by J. D. Hammond (1848).

WYMAN, JEFFRIES (1814-1874), comparative anatomist, was born in Chelmsford, Mass., Aug. 11, 1814, his father, Dr. Rufus Wyman, being the first physician of the Maclean Insane Asylum, the earliest institution of its kind in New England. Young Wyman was prepared for college at Phillips Academy, Exeter, entered Harvard in 1829 and graduated in 1833. He studied medicine with his father and Dr. Dalton and took the degree of M. D. in 1837. His first appointment after graduation was as demonstrator to Dr. J. C. Warren, professor in Harvard University. Soon afterward he received the appointment of curator of the Lowell Institute, and in 1841 delivered a course of lectures before the Institute. He used the money earned by this for a voyage to Europe and attended the lec-

tures of the most noted anatomists, physiologists, and natural historians in France and England. In 1843 he was appointed professor of anatomy and physiology in Hampden College, Richmond, Va., and in 1847, Hersey professor of anatomy in Harvard; and began the formation of the museum of comparative anatomy with which his name is associated. In its behalf he was wont to make long voyages in America, Europe, and Asia. In 1856 he was made president of the Boston Natural History Society, filling this position till 1870, and in 1857 was chosen president of the American Association for the Advancement of Science. On the foundation of the archæological museum by Mr. Peabody of London in 1866, he was appointed its curator, an office which, as well as the Hersey professorship, he held till his death. Prof. Wyman was one of the four members in addition to Prof. Agassiz who constituted the faculty of the Museum of Comparative Zoölogy, and entered with unflagging interest into all the large designs of his illustrious colleagues, who regarded him as ranking among the greatest comparative anatomists. A threatened attack of periodical catarrh compelled him in August, 1874, to leave Cambridge for the White Mountains, but before doing so he put both his museums into the most perfect order. On Sept. 4, 1874, he succumbed to a sudden hemorrhage which proved almost immediately fatal, the place of his death being Bethlehem, N. H. Prof. Wyman was the author of numerous scientific papers on anatomical and physiological subjects, the titles of 64 of which appear in the *Catalogue of Scientific Papers*, published by the Royal Society of London.

WYTHE, GEORGE (1726-1806), statesman, jurist, and signer of the Declaration of Independence, was born in Elizabeth City co., Va., of a wealthy family. His education was mostly private, and largely his own work in later years: his youth was spent in reckless dissipation. At thirty he altered his course, was admitted to the bar 1757, and the next year entered the House of Burgesses, where he acquired the greatest consideration and influence. He was one of the earliest and most ardent of patriots, and near the end of 1764 was a member of the committee appointed to draw up a petition to the king and addresses to Parliament. The remonstrance to the Commons on the proposed Stamp Act was written by Wythe, and his colleagues found it much too outspoken for prudence or propriety. As a member of the Continental Congress, 1775-7, he held the same views, and was ripe for independence. With Mason and R. H. Lee he framed the Virginia constitution in 1776; some months later, with Pendleton and his pupil Jefferson, he was set at a revision of the State laws. The next year he was Speaker of the House of Delegates and one of the three judges of Chancery; in this court he disregarded his popularity in maintaining the rights of British creditors. The war, which he so strongly favored, caused the loss of much of his property. He was professor of law at William and Mary College 1779-89. In the Constitutional Convention, and in that of Virginia, which ratified the document, he was active and prominent on the side of union. The court was reorganized in 1786 and he made sole chancellor. He was "singularly able to foresee the latent powers of great men, and help them to great careers." One of the most determined of the Virginia abolitionists, his will freed his slaves and made provision for them. To legal abilities and acquisitions of a high order he united a liberal taste for letters, eminent social gifts, and a fondness for instructing and influencing the young. He lived at Richmond from 1789, and there died by poison, June 8, 1806; judicial proceedings failed to bring the supposed murderer to punishment. Jefferson, to whom his library and instruments were bequeathed, said that "no man ever left a character more venerated."

Y.

YALE UNIVERSITY. This famous institution of learning at New Haven, Conn., was named from an early benefactor, Elihu Yale, F.R.S. (1648-1721), born at New Haven, to which his father Thomas had emigrated 1738. The family returned to England 1658, and he never revisited America, but went about 1678 to India, where he acquired wealth, married a native lady, and was governor of Fort St. George, at Madras, 1687-92. Taking home a quantity of Eastern products about 1700, he had them sold at the first auction known in England. He became governor of the East India Company. But his name is preserved by his gifts of books and money, amounting in all to nearly £500, to the nascent school at his birthplace. In 1717 Cotton Mather had advised these donations, and on their account the collegiate house, erected in 1718, received his name, which in the charter of 1745 was extended to the institution. He died in London, July 22, 1721. A college had been in view from the settlement of New Haven in 1638, but Massachusetts urged that Harvard was enough for all New England. The project was revived by a few ministers and on Oct. 9, 1701, a charter was granted for a "collegiate school," and the government vested in a rector and ten fellows, all clerical. Saybrook was chosen as "the most convenient place at present," and Pierson, pastor of Killingworth, put in charge. For six months he taught a solitary student at home; in September, 1702, seven more came, a tutor was chosen, and a commencement held. The transfer to New Haven in 1716 was vehemently opposed, and most of the library lost in the process. For many years the rector was assisted only by two or three tutors; the charter of 1745 changed his title to president. A professor of divinity was added in 1755, and in 1771 one of mathematics, physics, and astronomy, though this chair was not permanently filled till 1794. Before the Revolution occasional grants were made by the legislature; in 1792, the State gave some \$30,000, and added to the Board of Fellows the governor, lieutenant-governor and the six senior assistants in the Council. For the last senators were substituted from 1818, and these by request of the corporation were in 1872 displaced by graduates, one to be chosen annually, to serve six years. These have been the only changes in the government.

The presidents have been Abraham Pierson, 1701-7; Samuel Andrew, *pro tem.*, 1707-19 and 1722-5; Timothy Cutler, 1719-22; Elisha Williams, 1725-39; Thomas Clap, 1739-66; Naphtali Daggett, 1766-77; Ezra Stiles, 1777-95; Timothy Dwight, 1795-1817; Jeremiah Day, 1817-46; Theodore D. Woolsey, 1846-71; Noah Porter, 1871-86; Timothy Dwight (a grandson of his namesake), 1886. The growth of the institution has been chiefly within the present century. Under the vigorous administration of the first Dr. Dwight the faculty was strengthened in 1802 by the acceptance of Benjamin Silliman (for whom see *ENCYCLOPÆDIA BRITANNICA*), as professor of chemistry; in 1805 J. L. Kingsley was made professor of Hebrew, Greek, and Latin. A department of medicine was established in 1812, of theology in 1822, of law in 1824. As reorganized in 1871, the college has also departments of philosophy and the arts. The last now includes the academical department or "Yale College," the Sheffield Scientific School, begun 1847 and endowed 1869, the courses for graduates first arranged in 1847, and the School of the Fine Arts, founded in 1861 by A. R. Street.

Degrees were first given in law in 1843, in philosophy in 1852, in theology in 1867. The present number of graduates is about 13,000. There are some 72 professors, 50 or more tutors, instructors, lecturers, etc.; 117 students in divinity, 26 in medicine, 94 in law, 58 in fine arts, 291 in the scientific school, 69 in the graduate courses, and 614 in the college proper, making a net total of 1245. The annual cost of tuition in the college and scientific school is \$150, and in the other departments somewhat less; in that of theology it is free. Beneficiary aid is given to students needing it, and there are sundry fellowships, scholarships and prizes. Changes have recently been made in the direction of greater freedom of study, though to a less extent than at Harvard; in 1885 four-fifths of the work of the seniors, and over half that of the juniors, was made elective. Over ninety elective studies are now open, besides several courses of lectures. The Sheffield Scientific School received in 1863 through the legislature the national appropriation under the law of July, 1862, for agriculture and the mechanic arts, yielding some \$8000 per annum; it gives the degree of Ph.B. and of Civil and Mechanical (or Dynamic) Engineer.

The University buildings occupy a square of some nine acres in the midst of New Haven, adjoining the public green. They are numerous and of various dates; the most recent are the Sloane Memorial laboratory for physics, opened 1884; Lawrence and Dwight halls, 1886; and the Kent chemical laboratory. The handsomest is that of the School of Fine Arts, which cost \$175,000; to this the Trumbull paintings were removed in 1868. The Peabody Museum of National History was erected 1876, at a similar cost, from the proceeds of a gift made in 1866; it has geological, zoological and mineralogical collections, with a curator for each. The observatory was built from a bequest of O. F. Winchester. The University Library contains about 135,000 volumes, the Linonian and Brothers' Library 29,500, and those of various departments bring the sum total up to 188,000. The invested funds amount to \$2,000,000, and the annual income from tuition over \$100,000. *The Annals of Yale* were written to 1766 by President T. Clap, and to 1831 by E. Baldwin. Prof. W. L. Kingsley prepared its *History* (2 vols., 1879), and Prof. Franklin B. Dexter is engaged on a still more elaborate one, of which one volume has appeared. He has also published a neat *Handbook of the College*.

YANCEY, WILLIAM LOWNDES (1814-1863), proslavery politician, was born at Ogeechee Shoals, Ga., Aug. 10, 1814. After admission to the bar and a brief sojourn in South Carolina, he removed to Alabama, 1837, became an editor, was sent to the State Assembly and Senate, and to Congress 1844-7. For the next ten years he was little known to the country at large, but was gathering reputation and influence in what he considered his country. His whole mind and heart were given to the South and to her "peculiar institution," and of that cause he was the most adroit, brilliant and indefatigable champion, though he long labored, conspirator-like, in the dark. General attention was first drawn to him by the unauthorized publication of his so-called "Scarlet Letter," dated June 15, 1858, to James Slaughter; in this he assumed for the South a revolutionary attitude, urged the formation of committees of safety, and organization in the Cotton States to resist Northern aggression. Undaunted by this premature exposure of his plans, he continued his

crusade with almost unexampled energy and activity, laboring with tongue and pen throughout his section to bring Southern sentiment to a point at which continued union with the North would be no longer possible. He wrote, Sept. 4, 1858: "I am a secessionist and not a revolutionist, and would not precipitate, but carefully prepare to meet an inevitable dissolution," which became inevitable largely through his efforts. The biographers of Lincoln call him "the Wendell Phillips of the South, a born agitator, the brain and soul of the proslavery reaction." The course of the National Democratic Convention of 1860 was outlined and almost dictated by him three months before it met; at the Alabama Convention in January, he said: "The States' Rights men should present their demands. It denied, they should secede from the convention, appeal to the whole people of the South, and organize another." In the event of the election of a Republican to the presidency, he provided a plan for State conventions, whereby "the South should seek her independence out of the Union." As he said, so it was done. At the Charleston Convention in April, he was the leading spirit and (to Southern ears) the most welcome and persuasive orator. He showed the Southern members their mistake in admitting theoretical objections to slavery, and assured them that the only logical Democratic position was one of reverence for the institution as essentially good and holy. A majority having accepted Douglas's platform, the Alabama delegate set the example of withdrawal from the Convention, April 30, and were followed by those of the other Cotton States. At the Baltimore Convention in June, Yancey and his co-workers were present, and effected (if they had not done it before) a complete severance of the party, passing to a convention of their own at Richmond. These schemes of disunion had already been explained and denounced in the Senate (May 16) by Douglas, who bore witness to the "ability, courage and sincerity" of Yancey. He was in his element for the last time at the Convention of his State in January, 1861, requiring submissive reverence to the ordinance of secession from the Union, and urging "the penalties of treason" for those who disobeyed it, the members from the Northern counties, not then prepared to go all lengths at once, scoffed at his position, and burned him in effigy. He went abroad in March as a Confederate Commissioner to seek for recognition in Europe, but was unsuccessful; he was an agitator rather than a diplomatist, and could better kindle a fire than support or direct the flame. Returning in February, 1862, he was sent to the Confederate Senate, but died near Montgomery, Ala., July 28, 1863.

YELLOW FEVER. See FEVER.

YELLOWSTONE NATIONAL PARK. Of

the many striking examples of natural phenomena in America there are none to surpass those included within the limits of the government reservation known by the above title, which, by Act

of Congress of March 1, 1872, was "dedicated and set apart as a public park or pleasuring ground for the benefit and enjoyment of the people." The marvels of this locality, of which rumors had for some years been afloat, were first made known in 1869 by a party of surveyors who visited the Yellowstone region, and who were followed in 1870 by an expedition under Gen. Washburn, surveyor-general of Wyoming Territory. The report of its wonders excited much interest, and in 1871 a government exploring party under Professor F. V. Hayden visited, explored, and mapped the district, and gave the first detailed report of its striking features of natural scenery and phenomena. Congress at once took measures to preserve it from spoliation or speculative occupation, by setting it aside as a national park for

the permanent use of the people. It was well worthy of this prompt action, for in its special range of phenomena it has no rival upon the earth, and is well worthy the name of "The Northern Wonderland," which Professor Hayden gave it, in distinction from "The Southern Wonderland" of New Zealand.

The Yellowstone Park is situated in the extreme north-western portion of Wyoming Territory, extending slightly beyond its boundaries into Idaho and Montana, and embraces an oblong tract 55 miles east and west, and 65 miles north and south. Its area is 3575 square miles, the whole of which is at an altitude of more than 6000 feet above sea level. The Yellowstone Lake, which is included within its borders, has an altitude of 7788 feet, while its bordering mountain ranges are from 10,000 to 12,000 feet high, and covered with perpetual snow. This region, while containing varied examples of striking natural scenery, is specially notable for the hot springs and geysers which it possesses in extraordinary abundance, they being without parallel in the world in number and magnificence. These are the final stages of a great volcanic activity which seems to have affected the whole region in recent geological times, and whose temperature conditions still exist at no great distance below the surface. Outside this region, geysers (periodical eruptive springs) are found only in Iceland and New Zealand, the so-called geysers of California being rather fumaroles, or vapor vents. In magnificence of display, however, the great geysers of Iceland are far surpassed by those of the geyser basin of Firehole River, in Yellowstone Park.

The Yellowstone region is, in its geographical features, one of the most interesting of North America. Within its limits or in its vicinity are the sources of several of the great rivers of the continent, which flow from that centre to the east, west, and south.

On the north are the head waters of the Yellowstone; on the west those of the principal forks of the Missouri; on the south and southwest those of the Snake, an affluent of the Columbia, and of the Green, a branch of the Colorado; and on the southeast, those of the Wind River. The Yellowstone, a tributary of the Missouri, is, with the exception of the Colorado, the most remarkable river on the continent. It has its source in Yellowstone Lake, near the southeast corner of the park. This lake, 22 miles long by 10 to 15 wide, is nearly surrounded by snow-clad mountains, its waters are exquisitely clear, its shores rugged but picturesque. The lake is fed by the Upper Yellowstone, after a run of 25 miles from its sources. From its north end flows the main stream of the Yellowstone, with a course of 1300 miles to the Missouri. Near its point of exit from the lake is a belt of hot springs 3 miles long by $\frac{1}{2}$ mile wide, some of them extending into the lake. About 15 miles below the lake the river descends to the lower level in two magnificent cataracts, that known as the Upper Falls being 140 feet in vertical height. About a quarter of a mile below this are the majestic Lower Falls, one of the principal attractions of the park. There the stream falls down a declivity of about 330 feet in height, forming a cataract which far surpasses that of Niagara in beauty, though not its equal in grandeur. Below this the river enters the Grand Cañon, a mighty cleft in the volcanic rocks, 20 miles long, with perpendicular sides from 200 to 500 feet high. There is no scenery of the kind in the world that surpasses this cañon in sublimity, even the Grand Cañon of the Colorado, though exceeding it in dimensions, not surpassing it in grandeur of effect, while its many colored walls give it a magnificence of aspect not to be indicated by any description. Just below the cañon the main stream is joined by Tower Creek, which flows for 10 miles through a

deep and gloomy cañon known as Devil's Den, in which the basaltic rock is evolved into multitudes of tower-like pinnacles and columns, just above its mouth the creek breaks into a highly picturesque and beautiful fall of 156 feet in vertical height, which constitutes one of the chief attractions of the locality. Below this point the Yellowstone flows through an open country, bounded by lofty hills.

The Yellowstone, though not the region of the great geysers, possesses a remarkable abundance of hot springs, significant of excessive volcanic activity in past times. Some of these are dead, their former existence being indicated by calcareous deposits; others are evidently failing; but many are still in full activity. There is an interesting group of these springs on the east side of Mount Washburn, extending over an area of 10 to 15 square miles. But the most remarkable group, not merely in that locality but in the world, is that of the Mammoth, or the White Mountain Hot Springs, near the northern boundary of the Park. These extend from the margin of Gardiner's River, up the sloping side of White Mountain, to an elevation of nearly 1000 feet above the river level. As springs they are less remarkable at present than some of those in other regions of the Park, but the conditions produced by their former history give them peculiar value. An area of about two square miles is covered by snow-white calcareous deposits, which extend over the entire side of the mountain, and present the appearance of a series of frozen cascades.

The steep mountain sides are ornamented with a succession of semi-circular basins, with margins from a few inches to 6 or 8 feet in height, which are scalloped and adorned with bead-like tracery in every shade of scarlet, green, and yellow, on a white ground-work. The water from the active springs gathers in pools in these basins, and flows over their margins in cascades, gradually losing its heat as it descends the mountain slope. On the summit of the hill is a large spring, whose dimensions are 25 by 43 feet. Its water is perfectly transparent, while the sides and rim of basin are beautifully ornamented with coral-like and other forms of calcareous deposits, of many shades of color. The overflowing water of this basin makes its way down the hill in the cascades described, while the whole scene, with the delicate fretwork of its terraces and its exquisitely soft shades of color, is of a beauty seldom equalled. The branch of the Northern Pacific Railroad which enters the Park from Livingston, ends near this locality at Cinnabar, whence coaches convey tourists six miles further to the Mammoth Hot Springs Hotel, which is the initial point of the usual Park tours.

Another interesting locality on the Yellowstone, about ten miles below the falls, is Sulphur Mountain, which rises on the west side of the river to a height of 150 feet from a nearly level plain. This hill is perforated by numerous fissures and craters, from which sulphurous vapors issue in profusion, while the sides of the fissures are lined with crystals of sulphur, and the ground is hot from internal fires. Near by are some springs of boiling mud. Two miles to the east of this locality is another remarkable group of mud springs, and a few miles above Sulphur Mountain occurs what is known as Mud

Volcano, a crater of boiling mud 25 feet across. The surface of the mud is about 30 feet below the crater level, and is in constant ebullition, while dense clouds of steam rise to a height of several hundred feet. By the occasional explosive outbursts masses of mud are hurled to great distances. There are three large hot springs in the vicinity, one of them a geyser, with a period of activity about every six hours.

The whole region of the Yellowstone Park contains from 5000 to 10,000 hot springs. These are chiefly of two kinds, calcareous and silicated, and deposit lime or silica around their borders, often in elaborate and elegantly ornamented forms, whose colors vary almost as greatly as their shapes. The temperature of the calcareous springs range from 160 to 170 degrees or over, the boiling point of the region being from 198 to 199 degrees. The Gardiner River hot springs are principally calcareous; in other places, as on Firehole River, the springs are silicated.

The most surprising phenomena of the Park, its geysers, are principally found on the stream just named, and near Shoshone Lake, at the head of Lake Fork of the Snake River. Firehole River is a fork of the Madison, which in its turn is a tributary of the Missouri. Within the locality here indicated there are probably 50 geysers which throw columns of water to a height of from 50 to 200 feet, while the vents of all kinds number thousands. On every side is seen evidence of volcanic activity on

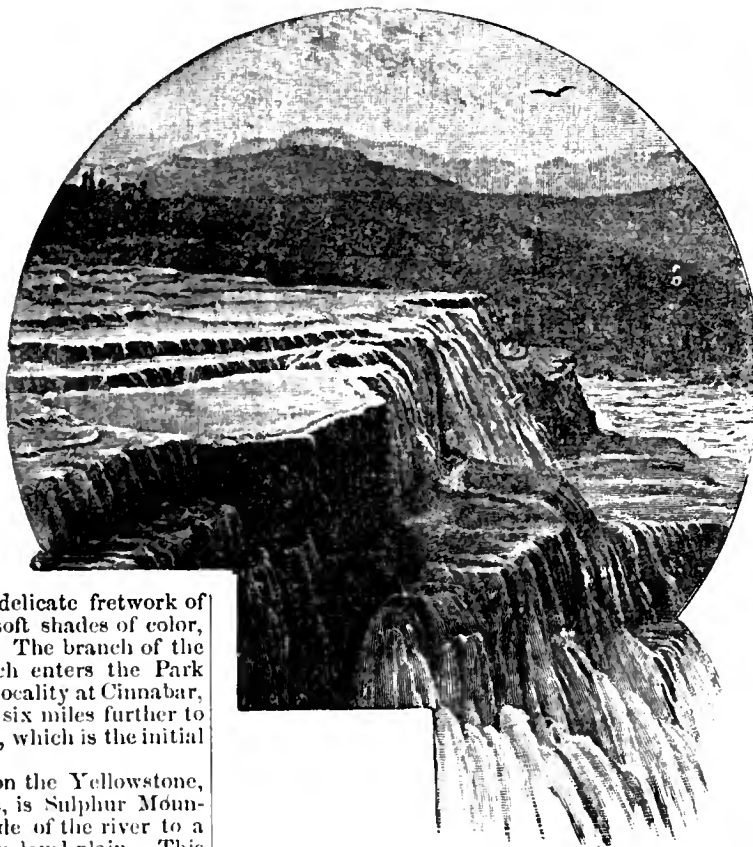

Pulpit Terrace.

a stupendous scale in past ages, of which the geysers and hot springs form the slowly subsiding remnant throughout the Park, indeed, the work of ancient lava outflows is visible in broad sheets of basalt, which form mesas or table lands in the valley, while on the hills volcanic breccias are weathered

into varied and fantastic forms. On the Firehole River the geysers compose two large groups, included within an area of about 30 square miles. Here much of the ground is covered with a snowy



Mud Volcano.

deposit from the geyser waters, while the surface of the variously shaped mounds from which the waters spring is in some cases exquisitely ornamented by deposits like "scalloped embroidering set with pearly tubercles." In other cases the deposit of silica assumes the most fantastic forms. Occasionally it is deposited in a gelatinous condition to a depth of 3 or 4 inches, resembling starch paste. Trunks and branches of trees immersed in these waters quickly become covered with a stone-like deposit of silica; or are petrified, in popular language.

Of the two geyser basins on the Firehole, the Lower Basin contains a number of interesting geysers, about half a dozen in all, one of which throws a column of water to the height of 60 feet and another to half this height. Its boiling springs number 63 in all. Between the two basins are the Half-way Springs, the principal one of which is a large cauldron of 250 feet diameter, with walls of about 20 feet high. From it rise constant clouds of steam, while its overflowing waters make their way to the river over a snowy platform of their own deposits. In this locality is the great Excelsior Geyser, whose eruptions are very irregular, but whose great power is attested by the roar which accompanies its outbursts, and the dense volume of steam which it emits.

The Upper or Great Geyser Basin is far more wonderful than the lower in its manifestations of subterranean activity, and as a geyser group has no parallel in the world. It covers an area of about three square miles, extending for several miles along the river, with a width from half a mile to a mile. The river banks here are composed of silicious deposits of the springs, and, in the words of Professor Hayden, are "literally honey-combed with springs, pools and geysers that are constantly gurgling, spitting, steaming, roaring and exploding." Most of the springs and geysers are near the river. The springs are very numerous, there being 414 boiling springs, and many others of lower temperature and tranquil. The average temperature is about 170°. The large geysers number 26 in all. At the head of the valley, near its southern extremity, appears the remarkable geyser, known as Old Faithful, from the frequency and regularity of its discharges. At intervals of about an hour it shoots up a column of water 6 feet in diameter to a height of from 100 to 150 feet, continuing to play for about 6 minutes. When it ceases the water disappears, but an underground hiss of steam indicates the continued activity of the eruptive forces.

On the other side of the river from Old Faithful is the Beehive, so called from the shape of its mound. It throws a column of 2 or 3 feet diameter to a height of from 100 to 220 feet, and continues to play from 5 to 15 minutes. About 200 yards distant is the Giantess, one of the largest of the geysers. This has an oval aperture of 18 by 25 feet, down which one can look for a hundred feet without seeing water, though it can be heard gurgling below. At intervals of about 11 hours, however, the water is hurled upwards in a grand column of 20 feet diameter, to a height of 60 feet, while several smaller jets rising through this carry the discharge occasionally to the extreme height of 250 feet. The eruption continues for about 20 minutes. At a short distance, Sawmill Geyser throws an almost continuous steam to a height of 10 or 15 feet; while near by is Grand Geyser, one of the most powerful, its column of 6 feet diameter at bottom being thrown in a succession of jets to a height of 175 to 200 feet, and continuing for 20 minutes. Its period of eruption is irregular, and is preceded by rumbling noises and shaking of the ground, while the cloud of steam which accompanies the eruption ascends to a height of more than 1000 feet.

Near Grand is a small geyser, known as the Turban, from the peculiar shape of its mound, and beyond this is Giant Geyser, whose water is thrown from a cone 10 feet high and 25 feet diameter at base, diminishing to 8 feet at top. This throws a column of 6 feet diameter, and plays for hours. In 1871 Dr. Hayden found it to play 1 hour and 20 minutes, the water being thrown to a height of 140 feet, but Lieut. Doane, who visited the locality in the preceding year, describes it as playing 3½ hours at times, and throwing its column from 90 to 200 feet. In addition to the geysers described may be named the Castle, which in 1870 threw a column 3 feet in diameter to a height of 140 feet for 3 hours together, and in 1874 played for 40 minutes to a height of 250 feet; the Grotto, throwing its stream from 25 to 60 feet; the Punch Bowl, the Soda, the Pyramid, the Bath, etc., all named from certain peculiarities of form or character, while others worthy of notice are yet unnamed.

Another geyser basin exists at the west end of the western arm of Shoshone Lake, its springs and geysers being said by Prof. Hayden to be not surpassed in beauty and hardly less active than those of Firehole Creek. North of the Firehole geyser basin is the Norris Basin, which contains two important geysers, the Monarch and the Hurricane, the latter a recent outburst, and one of the most

vigorous displays of subterranean energy to be seen in the Park. Between this and the Firehole basin is the Gibbon Paint Pot basin, with 500 springs of boiling mud, of every shade of color, and the Gib-

gers within the northern boundary of the Park. Hotels have been built, and several others are to be erected, so that ere long the whole Park promises to be well provided with accommodation for travellers.

Then, too, excursion arrangements are so shaped, that tourists can enjoy the pleasures of the Park in complete safety and at greatly reduced cost. The way to see the wonders of the Park to best advantage, is, at present, by camping out, while all its important localities can be readily visited on horseback. In addition to the marvels of scenery there is excellent hunting and fishing, the Park being full of large and small game, while the rivers and lakes afford excellent sport to the angler. The Act of Congress forming the Park, however, provides that the Secretary of the Interior shall take steps to prevent a wanton destruction of fish and game within its boundaries, and against their capture or destruction for merchandise or profit.

This provision is destined to prove of great advantage in the preservation of the heritors of the West, the bison, elk, antelope, Rocky Mountain sheep, etc., which have of late years been so recklessly slaughtered, and which are threatened with speedy extinction. It is reported that of those animals a few hundred bisons, and several thousand elk, deer, antelopes, and mountain sheep have found a place of refuge within the limits of the Park, and with proper protection, which will no doubt be accorded, there need be no need of these interesting species becoming extinct. Their presence here, if they become

extinct elsewhere, will in the future add another to the many attractive features of the Yellowstone National Park. (C. M.)

YOSEMITE VALLEY. The remarkable and famous mountain cleft or valley known under this title (which is of Indian origin and signifies "large grizzly bear") is situated on the course of the Merced River, in Mariposa County, California, on the western slope of the Sierra Nevada Mountains, and nearly midway between the northern and southern extremities of the State. It is distant 140 miles from San Francisco, in a line nearly due east, but over 220 miles by the usually travelled routes. The valley through which flows the Merced is nearly level, its length being about 6 miles, its width varying from $\frac{1}{2}$ mile to nearly 2 miles, but in that small space is found some of the most magnificent natural scenery in the world. The valley, in fact, is inclosed between lofty granite walls, which rise almost vertically, and are from 3000 to 6000 feet in height; this height being rendered more impressive by the absence of a talus, or sloping heap of debris, at their feet. At several points over these precipitous walls flow streams, which in the season of rains and melting snows form cataracts of unrivalled beauty and magnificence. In the early spring, indeed, to the larger waterfalls are added numerous cascades, as the minor streams and rivulets made by the rains flow over the edge of the mountain walls, and dart downward in lines of glancing light to the valley below. At this season the combined effects of cascades and cataracts give an indescribable beauty and grandeur to the scene. The nearly vertical walls of the valley and their great height, both absolutely and as compared with the width of the space between them, with the added charms of the waterfalls, form features of unusual attractiveness, to which may be added the fact that during the proper season the valley is one vast flower bed, the ground being carpeted thickly with plants of great variety, which bear flowers of every hue and of great brilliancy of color, while the air is filled with their fragrance. Trees also in great variety adorn the val-

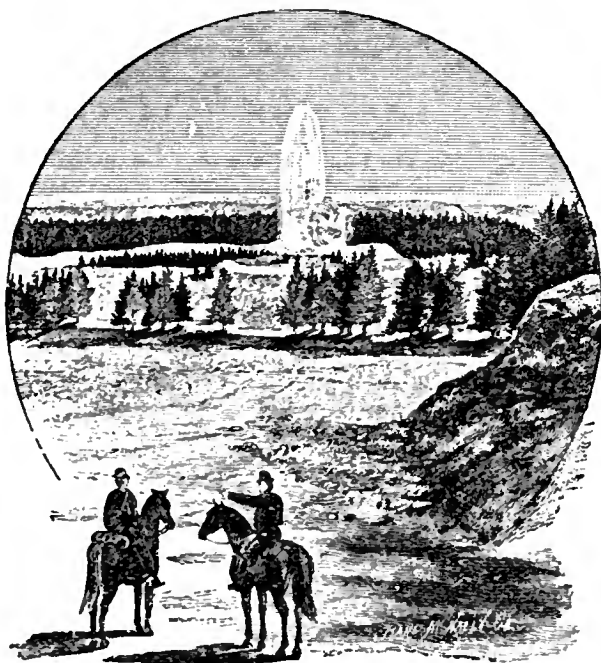

"Old Faithful" Geyser.

bon Cañon and Falls, the latter a beautiful cascade of 160 feet height.

The curiosities here named are by no means all the marvels of the Park; there are hot springs

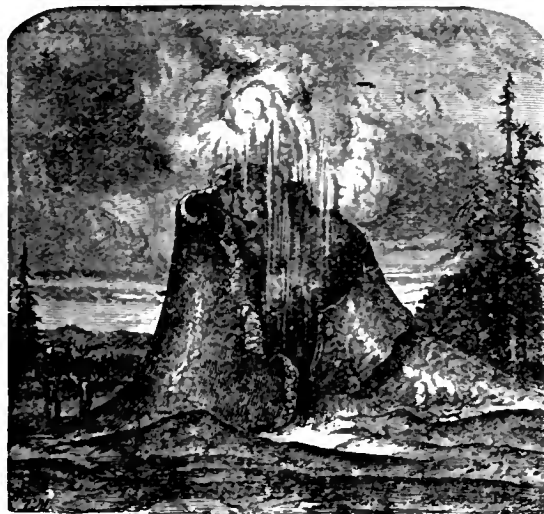

Crater of Giant Geyser.

falls, and other attractions in several other localities, and there is scarcely a portion of the Park without its objects of interest. It is doubtful if there is any locality on the face of the globe that contains so much of the attractive and wonderful, while it is said to surpass in the number of its hot springs and geysers all the remainder of the earth.

The Park was formerly difficult of access, but the railroad extension of recent years has overcome this difficulty, there being a Yellowstone Park branch of the Northern Pacific Railroad which lands passen-

ley level, some of them of centuries' growth and great loftiness, though they are dwarfed by the towering cliffs against which they measure their height. To these varied elements of beauty must be added the stream which wanders down the centre of the valley. It is of mountain origin and icy cold, while its water is so clear that every detail of its bottom can be seen, the mountain trout which haunt its depths being revealed in all their graceful charms to the eye of the eager angler.

The Yosemite was discovered in the spring of 1851 by a party of soldiers in pursuit of a band of predatory Indians, who made this valley their stronghold, considering it inaccessible to the whites. The report of its great beauty quickly brought tourists thither, and has spread until the Yosemite Valley has become one of the places of pilgrimage of the sight-seers of the world. In 1864 Congress took measures to preserve this remarkable locality from the greed of speculation by setting it aside as a permanent national park. The Yosemite Valley and the Mariposa grove of big trees were granted to California on the express conditions that they should be kept "for public use, resort, and recreation," and "be inalienable for all time." They were placed under the care of guardians appointed by the government, the guardian of the Yosemite residing in the valley during the season in which it is accessible to visitors, and having under his direction a small army of guides, drivers, care-takers, and others who make up the resident population. In addition to the residence of the guardian, the valley contains three well-kept hotels, a post-office, a small chapel, in which religious services are held, and various minor buildings, such as stables, guides' cottages, etc., these being all so situated as to detract in no sense from the attractions of the natural scenery.

In passing up the valley from its outlet the first grand feature that meets the eye is the huge and lofty cliff known as "El Capitan." This is not so high by several thousand feet as some of the others, yet rises so vertically from base to summit, and stands out so prominently from the general line of the mountain wall as to make it the most striking feature of the valley, and the chief of its lofty cliffs. "El Capitan" is 3300 feet high, its sides are bare and smooth, and, in the words of Prof. J. D. Whitney, "it is doubtful if anywhere in the world there is presented so squarely cut, so lofty, and so imposing a face of rock."

As if to soften the grandeur of this great cliff, on the opposite side of the valley there descends in indescribable charm one of the most beautiful of its many cascades, the celebrated Bridal Veil Fall. In this fall the stream leaps from the brow of a cliff 900 feet high, and comes down in a broad sheet of tremendous white spray, which is converted into mist by the depth of the descent. As it is swayed by the wind in ever-changing yet ever-pleasing outlines, the title given it seems most appropriate to its fleecy beauty. Opposite this fall, down a deep recess of rock near the lower corner of El Capitan, the Virgin's Tears Fall flows over the cliff and descends 1000 feet, in a beautiful cascade, which, however, is only visible during the early spring, the stream completely disappearing during the dry season. In fact a visit in the season of rains and of melting snows is necessary to see any of the falls in their perfection, the largest of them losing much of its beauty in the period of drought.

A short distance above the Bridal Veil Fall appears Cathedral Rock, a nearly vertical cliff, 2660 feet high; and just beyond it tower The Spires, two graceful columns of granite which are in part isolated from the valley walls, and rise above the edge of the cliff like the towers of a Gothic cathedral. From one point of view they appear of equal height and

symmetrical form, and add much to the charm of this portion of the valley. Further up, and on the opposite side, rises a triple group known as the Three Brothers, or, as named by the Indians, the Pompompasus or Leaping Frog Rocks. They seem, indeed, from below, like three huge frogs sitting with their heads all turned in the same direction. The highest of them is 3830 feet in altitude, and affords from its summit a superb view of the valley and its surroundings. Nearly opposite these projects a cliff which terminates with a slender obelisk of granite. The total height is 3043 feet, and its resemblance to a gigantic watch tower has gained it the name of Sentinel Rock.

Directly opposite Sentinel Rock appears what is justly regarded as the most wonderful feature of the valley scenery, the grand and lofty Yosemite Falls, which descends in all 2660 feet in two cataracts and a series of cascades. The first of these is a sheer fall of 1500 feet. Then the stream descends 626 feet in a series of cascades, and makes a final plunge of 400 feet to the bottom, seeming to shake the earth as it strikes the ground, while its roar can be heard far away. The stream is about 25 feet in width at the crest, while the total depth of the descent is more than a half mile. No other cataract in the world can compare with this in height and romantic beauty, the celebrated Stubbach of Switzerland being greatly its inferior both in height and volume. It is seen at its best from May to July. In August and September both this and the Bridal Veil Fall shrink almost to nothing from decrease in volume of their feeding streams. East of the fall is a cliff 3030 feet high whose summit is easily reached by a trail up Indian Cañon and affords a magnificent view of the whole region.

At a short distance above the Yosemite Falls an affluent flows into the Merced, making its way to the level below, not by a cataract but down a deep gorge known as Teneya Cañon. At this point are some of the most remarkable cliff effects of the whole valley. From the northern wall rises a lofty columnar mass known as Washington Column, immediately to the left of which is a series of immense arches in the rock strata named The Royal Arches. Above these towers the symmetrical North Dome to the height of 3568 feet. Opposite to this, on the other side of Teneya Cañon, rises the loftiest and most imposing of all the cliffs of the valley, the vast granite crest known as the Half Dome, which ascends to a height of 4737 feet. This mighty cliff, nearly a mile in vertical height, was long considered inaccessible, but in 1879 improvements were made by which tourists can now reach its summit, though not without a long and weary climb. Between these domes lies in the bed of the cañon the exquisite little Mirror Lake, formed by an expansion of Teneya Fork, while beautifully reflect in its sparklingly clear surface the surrounding cliff and the overhanging mass further up the cañon called Mount Watkins.

The main valley ends about two miles above Yosemite Falls. Here it branches into two cañons, one traversed by the main stream of the Merced, the other, or South Fork Cañon, traversed by a stream of minor size, yet which, at some distance up the rough and difficult cleft, descends in a fine fall estimated at 600 feet in height, which has received the soft sounding name of Illinoet Fall. Down the main cañon flows the Merced River, its waters making their way from the upper level in two grand cataracts and a series of rapids and cascades which are among the most attractive features of the valley scenery. The first fall reached in ascending the cañon has been named Vernal Fall. Here the whole stream, of perhaps 100 feet in width and of considerable depth, plunges vertically downward about 400 feet in a cataract of great grandeur.

A steep path, whose difficult portions have been made easy of ascent by a stairway, lead to the summit of this ledge, from which a line view down the cañon can be had. For a mile beyond this point the river flows in a series of cascades and rapids of striking character, the water rushing with a force approaching that of the rapids at Niagara, while on the north side of the cañon appears a huge isolated, and nearly perpendicular mass, known as the Cap of Liberty, 2000 feet high, and little inferior to the Half Dome in grandeur. Beyond this is seen the second fall of the Merced, Nevada Fall, which in height, volume, and impressive character of the surrounding scenery, ranks with the grandest waterfalls of the world. The height is about 600 feet, but the descent is not quite vertical, there being a rocky ledge near the summit which throws a part of the water aside with a peculiar twist which gives the fall a character of its own and adds greatly to its scenic effect.

Such are the principal features of this remarkable valley, which, taken as a whole, with its great variety and profusion of grand and beautiful scenery, is matchless among the valleys of the world. In the vicinity of the Yosemite are waterfalls which elsewhere would be considered as marvels of scenery, but which are left unnoticed by travellers in consequence of the much greater attractiveness of those of the valley. The cañon of the Tuolumne River, parallel with and a few miles north of the Merced, is full of attractive scenery, the stream descending 4650 feet in a flow of 22 miles, and presenting at short intervals cascades of great beauty and variety. At its mouth the gorge opens into a valley resembling the Yosemite in its general features, yet inferior to it in grandeur, and lost sight of in the superior charm of its neighboring rival.

Of the several localities from which a general view of the valley may be had, three deserve special mention. One of these, well named Inspiration Point, is situated at the entrance of the valley. Here the Merced flows through a deep and narrow gorge, and entrance can be effected only by a climb over the lofty cliffs at one side or other of the river. In this climb the tourist suddenly finds himself on Inspiration Point, and the whole valley laid out before him in one grand bird's-eye view, in which its looming cliffs and gleaming falls are all visible up to the point where the Merced flows out from its cañon to the broad level of the valley. The first view but adds zest to the delight with which the marvels revealed are afterwards to be seen near at hand. Up the valley nearly opposite the mouth of Tenaya Cañon is another outlook, known as Moran's Point, being the point of view from which the artist, Thomas Moran, sketched his celebrated picture of the Yosemite Valley. This point of view is 2000 feet high, and brings under the eye most of the scenic effects of the valley. A yet more embracing view can be had from Glacier Point, just east of Moran's Point, and about 3000 feet high. From this height the tourist can look over the obstructions to view at lower altitudes, and take in almost the entire valley at a glance.

As to the formative agencies of this noble production of nature scientists somewhat disagree, though the balance of evidence seems in favor of the active agency of glaciers in scooping out the valley. Abundant traces of glacial action can yet be seen, some of the cliff sides being polished to a slippery smoothness by the action of the ice. Earthquakes also seem to have had their share in the work, and huge fragments of rock now lie on the valley level, which have evidently been torn from the summits of the cliffs above. Probably still other agencies were at work, for nature seldom performs such mighty labors with a single tool. The whole surrounding scenery is full of evidence of titanic forces, and from the

summit level above the valley the Sierras present a magnificent panorama of mountain and valley scenery, unsurpassed even in Switzerland. (C. M.)

YOUMANS, EDWARD LIVINGSTON, editor of scientific publications, was born of poor parents, June 3, 1821, in Albany co., N. Y. Assisting his father in the work of the farm, the want of means, and also an affection of the eyes, that adhered to him throughout life, prevented him from entering college. Later he studied medicine, and devoted himself to popularizing the sciences, in which he discovered a remarkable aptitude, both as a lecturer and as a compiler. He avoided technicalities, and his style was distinguished by a clearness of phrase and elegance of diction little known till then in the scientific domain. It was doubtless owing to the reputation he had acquired, in these respects, as well as to his powers of broad, though strictly scientific generalization, that he was named, though himself a non-collegian, for the presidency of Antioch College, which he declined. However, he accepted there, in 1866, the chair of chemistry, as non-resident professor, and delivered a course of lectures. In 1856 the writings of Herbert Spencer attracted his attention, and thereupon a correspondence ensued which led to a life-long friendship, which brought about the publication of Spencer's works in America. In 1872 Prof. Youmans induced Messrs. Appleton & Co., of New York, to start the *Popular Scientific Monthly*, which, under his editorship, attained deservedly high position among the scientific periodicals of the world. He also planned the "International Scientific Series," comprising works by the ablest European and American authorities, and went to Europe to perfect the scheme by which the simultaneous publication in London, Paris, New York, Leipsic, Milan, and St. Petersburg was inaugurated. Besides his contributions to the two works, *Correlation and Conservation of Forces* (1864) and the *Culture demanded by Modern Life* (1867), Youmans prepared the "*Class-book of Chemistry*" (1851), the "*Hand-book of Household Science*" (1857), and other manuals. In his editorial labors he was constantly and ably assisted by his sister, Miss Elizabeth L. Youmans. He died at New York, Jan. 18, 1887. (J. W. W.)

YOUNG, CHARLES AUGUSTUS, astronomer, was born at Hanover, N. H., Dec. 15, 1834. He graduated at head of his class at Dartmouth College, in 1853, then taught classics at Phillips Academy, Andover, Mass., until 1856, when he accepted chair of mathematics, natural philosophy, and astronomy in Western Reserve College, at Hudson, Ohio. He was called thence in 1865 to Dartmouth College to assume the same chair, in which he had been preceded by his father and grandfather. In 1877 he removed to Princeton College, N. J., to take the chair of astronomy. He was entrusted with an expedition to Denver, Col., to observe the eclipse of the sun on July 29, 1878. As member of the observing party at Burlington, Iowa, of another eclipse, Aug. 7, 1869, he discovered the green line of the corona spectrum, and identified it with line 1.474 of the solar spectrum. As member of the Coast Survey observing party, on Dec. 22, 1870, at Jerez, Spain, he discovered what is called the "reversing layer" of solar atmosphere, giving a bright-line spectrum correlative to the ordinary dark-line spectrum of sunlight. As member of the Coast Survey party at Sherman, Wyoming Territory (summit of the Pacific Railroad), he made solar spectroscopic observations. In 1874 he was assistant astronomer in Prof. Watson's party to Peking, to observe the transit of Venus. He devised a form of automatic spectroscopic; established what is known as Doppler's principle applied to light experimentally, and measured the sun's rotation by the displacement of the lines in the spectrum. Prof. Young is a member of the National Academy of

Science, and other prominent learned societies. He holds high rank as a writer of scientific papers. He has lectured in various cities, and by his treatise *The Sun* (International Science Series) (1881), he has popularized the topics of solar physics and spectroscopy. His latest publication is a *Manual of Astronomy* (1888). (J. W. W.)

YOUNG, EDWARD, statistician, was born Dec. 11, 1814, at Falmouth, Nova Scotia. After receiving academic education, and spending some years in Windsor, N. Y., in mercantile affairs, he emigrated in 1835 to Indiana, where he engaged in business. In 1840 he returned to his native province, married and settled in Halifax, N. Y., where besides his commercial pursuits he edited the *Olive Branch*, a pioneer temperance publication. After sustaining losses in shipping, he removed in 1849 to Boston, and, in 1851, to Philadelphia where in partnership with E. T. Freedley, he published books and a weekly newspaper devoted to American industries. Their most important publication was *A History of American Manufactures from 1608 to 1846* (3 vols.), edited by Dr. J. L. Bishop, his wife's brother. A statistical work compiled by Mr. Young having attracted attention he was offered and accepted a place in the U. S. treasury department, removing to Washington in 1861. Here, as chief of division, he superintended the compilation of the statistics of industry and prepared for publication a voluminous report on the *Manufactures of the United States*, the precursor of all such reports. In 1865 he accepted a place on the revenue commission tendered by its chairman, Hon. D. A. Wells, but soon resigned. On Mr. Wells' recommendation Congress authorized the establishment of a bureau of statistics, and when this was organized in 1866 Mr. Young was made its chief clerk. After a few months, he was promoted to be chief of the bureau, which under his management became the peer of the older similar institutions in Europe. In addition to the official reports, Mr. Young published a *Special Report on Immigration* (1871), which was translated into German, French, and Swedish, and circulated by tens of thousands throughout Europe, the result being a great annual increase in the influx of immigrants. In the same year he published a *Special Report on the Customs—Tariff Legislation of the United States*. For these two works the Columbian University conferred on him the degree of Ph.D. His most important work is *Labor in Europe and America* (1875), which gives the results of personal investigation of the condition of the working classes. Dr. Young withdrew from the bureau of statistics in 1878, and lent his services for a few months to the Canadian government in the construction of tariff-tables, etc. He has since been U. S. Consul at Windsor. (J. H.)

YOUNG, ROBERT (1822-1888), author of the *Analytical Concordance*, was born at Edinburgh, Scotland, Sept. 10, 1822. He became a printer, then a bookseller, editor and publisher of many works in Hebrew and other Oriental languages. In 1856 he went to India to superintend the Mission press at Surat. After his return in 1861, he conducted for some years a missionary institute, and in 1867 visited the United States. He was still diligent in labors connected with the Bible, its original languages, and its interpretation. In his well-known *Analytical Concordance* he gives 311,000 references, and furnishes various means of comparing the English text of any passage with the original. He afterwards prepared *Contributions to a New Revision; Concordance to 8000 chapters of the Revised New Testament; Dictionary and Concordance of Bible Words and Synonyms; Twofold Concordance to the New Testament*, and other helps to the study of the Scriptures, besides an excellent translation of the New Testament. He died Oct. 14, 1888.

YOUNG MEN'S CHRISTIAN ASSOCIATION.

Within the past half century organizations of men have been formed under this name for the purpose of carrying on evangelical work in addition to that commonly performed by the system of Protestant churches. In 1845 the first Association of this kind was formed in London, and in 1851 the first one in America was organized in Boston. The second Association was formed in Montreal; the third in Buffalo; and the fourth in New York city. The general American Association, in its early days, met in annual conference; but latterly has convened once in two years. It was at the instance of the American Association that the first International Conference was held in Paris in 1855. At that conference the "Evangelical Test" was adopted, which limits the active membership to members of Evangelical churches. Every association admits others as associate members, but they are not allowed to vote upon amendments to the constitution, or to hold offices.

The latest reports (1888) of the condition of the organization show that there were 3804 associations in the world at the time when the tabular statements were prepared, of which 1240 were in the United States and Canada. Great Britain has 624, Germany 673, and the rest of Europe 1171. The remaining associations are scattered through Asia, Australasia, South Africa, South America, Mexico, and other countries. The island of Ceylon has 15. Full statistics of membership, property owned, and like details are available only in regard to the American associations, but the strength of the Y. M. C. A. in the world may be inferred from the fact that in 1888 the American associations, one-third of the total number, have 175,811 members, showing an increase of about 29,000 or 13 per cent. in one year. These American associations have real estate to the value of \$6,708,230, showing an increase of about \$1,100,000, or nearly 20 per cent. in a year. The total value of the property owned is put at \$7,261,628, and there are pledges for building funds to the amount of \$1,325,000. In 1887 about \$1,200,000 was spent to carry on the associations in the United States and British America, or \$200,000 more than in 1886. The buildings erected for the several associations in the cities of New York, Philadelphia, Boston, Buffalo, Cleveland, and Albany are of a most beautiful and substantial character.

Briefly stated, the work accomplished by the associations may be given as follows:—1. They have founded such historic union prayer meetings as those in Fulton Street, New York, from 1856 to the present time, and in Jayne's Hall, Philadelphia, from 1857 to 1863. 2. They have acted the part of Howard societies in seasons of devastating epidemics. 3. During the civil war they organized and supported the U. S. Christian Commission, which followed the armies with beneficent ministrations to the bodily and spiritual wants of the soldiers. (See CHRISTIAN COMMISSION.) 4. The American associations originated and secured stringent legislation in the United States for the suppression of obscene literature, and began the vigorous efforts still continued for the thorough enforcement of this legislation. 5. They have stimulated a taste for the best reading by carefully selected libraries. 6. They have encouraged the most instructive class of lectures. 7. They have been foremost in evangelistic services in their home fields and throughout entire states and provinces. 8. In times of sudden calamity to any community by fire, storm or flood, they are ever ready as almoners of the benevolent to distribute wisely their contributions in aid of sufferers, and in scores of cities and towns during the trying season of the year they secure and discriminatingly use funds for the

relief of the deserving destitute poor of the community.

In reviewing the work of the American associations since the close of the civil war, the following points seem worthy of special notice: 1. The American associations have sought to give rightful prominence to specific work for the improvement of young men. 2. They have maintained their organizations for the purpose of associating Christian young men in this work for their fellows. 3. They have insisted that this improvement is to be sought primarily by the conversion of the soul and the consecration of the life to the love and service of Jesus Christ. 4. They have united Christians of the various churches in this work and in other work that can best be performed by united effort. 5. In summer they hold hundreds of open-air services every week. 6. In thinly settled districts they have united the active members of various churches in holding meetings in homes and school-houses. 7. They carry the gospel among the 800,000 railroad employes of the country. 8. They organize the young men in colleges for Christian work. 9. They co-operate with German-speaking Christian young men for the salvation of their fellows. 10. They bring together into Christian sympathy and companionship the young men of Canada and the United States, the young men of the North and the South, so promoting peace upon earth, good will to men. 11. This broad, deep work they accomplish by insisting that Christian laymen are called of God to give time and effort as well as money to active service in winning souls and leading them to Christ. 12. While these associations are each individually active in carrying on this varied and useful work, they also meet yearly in international, state and provincial conventions, and by means of deliberative action and efficient committees promote the common cause.

The several states have passed laws incorporating nearly all of these associations within their borders. A state executive committee of the Young Men's Christian associations of the State of New York was incorporated in 1886. The same state, in 1883, passed a law incorporating the International Committee of Young Men's Christian Associations. This committee is to be composed of not less than 27 members, one-third of whom are to be elected at each of the international conventions.

As a consequence of the great and good work accomplished by the Young Men's Christian Association, Women's Christian Associations have also been organized to carry on a similar work among females.

(F. G. M.)

YUCCA, a peculiar genus of the family of *Liliaceae*, which is a native of North America, from New Jersey and Iowa to Yucatan, and is most abundant between 25° and 35° N. lat. There are about a dozen well characterized species and many varieties, the stems of the more northerly species being under-

ground, and sending up a tuft of bayonet or dagger-shaped leaves; while the more southerly have an aerial stem, palm-like in some species, the trunk, which reaches 10 to 20 feet in height, being crowned with a dense tuft of leaves. The yucca is known by various common names, as bear-grass, Adam's needle, and Spanish bayonet. *Y. filamentosa*, to which the first two of these names are given, is found in sandy soil from Florida to Virginia and westward. The trunk rises to a foot or less above the ground, and is crowned with the lance-shaped, unarmed, coriaceous leaves, which bear delicate filaments on the margins. It is from these threads and the sharp-pointed leaves that the name Adam's needle is derived. *Y. angustifolia*, which is abundant between the Mississippi and the Rocky Mountains, is known as the soap plant, the root stocks of this as of other species being full of mucilaginous and saponaceous material, which, under the name of amole, is used as a substitute for soap in many Mexican houses, and also by the negroes of the South. Its leaves are from 1 to 3 feet long, and very stiff and pointed.

Two other United States species, *Y. aloifolia*, the Spanish bayonet, and *Y. gloriosa*, occur from North Carolina southward. The latter gets its title from its magnificent inflorescence. The flowers of the yucca are borne on a flower stem, which rises from the centre of the leaves, and bears a large panicle of snowy white, lily-like blossoms, which are attractive at all hours, but particularly so in the evening, when the flowers are fully expanded. The fruit of the yucca is dry in some species, fleshy in others, and in the latter cases is edible and savory. It is eaten by the negroes of the coast regions of South Carolina and Georgia under the name of banana, which it somewhat resembles. The fruit of *Y. baccata*, a species of Arizona and the neighboring States, is largely eaten in the fresh state by whites and Indians, and is cured by the Indians for winter use. The roots of some species abound in farina, and are used by the Indians as food. Another species is *Y. recurvifolia*, of the sea-coast of Georgia, whose white flowers are occasionally tinged with green and purple.

Several species of yucca are planted for ornament in landscape gardening, while all the plants of the genus have an important economical use, as they yield a fibre of great strength and value. Sisal hemp comes from a member of this genus, and from the leaves of every species may be obtained a long staple. *Y. gloriosa* furnishes a fibre of extreme durability, which is used for cordage, rope, and packing cloth. *Y. filamentosa* also yields a strong fibre, from which ropes have been made of unsurpassed strength. As these plants grow spontaneously on light sandy soils, often of the poorest character, from Virginia to Florida, and are very hardy, they may become of considerable economic value as fibre-yielding plants.

(C. M.)

Z.

ZECHARIAH. See PROPHETS.

ZEISBERGER, DAVID (1721-1808), missionary to the American Indians, was born April 11, 1821, at Zauchenthal, Moravia, and educated at Herrnhut. In 1738 he followed his parents, who were descended from the Bohemian Brethren, to Georgia and two years later removed with them to Pennsylvania, and had a share in founding Bethlehem and Nazareth. In 1743 he narrowly escaped being sent back to Germany with Zinzendorf. In 1745 he began to preach and labor among the Delawares at Shamongkin, and soon transferred his efforts to the Iroquois

at Onandaga, N. Y. For 63 years he lived in the woods, devoted to his pious calling, in which he displayed zeal and fortitude not surpassed by any of the Canadian Jesuits, taking long journeys on foot and by canoe, indifferent to hardships and perils. At first he met a good degree of apparent success; the Six Nations adopted him (as did afterwards the Monseys), made him a sachem, and entrusted him with their records. The commotions of those times sadly disturbed and interrupted his peaceful work, and between contending parties or armies, he was exposed to troubles and suspicions, as in the French

war. He settled with his converts at Wyalusing, on the Susquehanna, after the conspiracy of Pontiac, and in 1767 started a mission on the Alleghany. In 1772 he founded Schoenbrunn on the Tuscarawas, in Ohio. After nine years of increasing prosperity and influence, his loyal service to the American government, in preventing the Delawares from taking the field against it, was punished by the British authorities at Detroit, who instigated the Wyandots to destroy his settlements, and had Zeisberger and his assistants tried as spies. What was left of his work was ruined in 1782 by the massacre at Gnadenhütten, in which ninety-six Christian Indians, peacefully returning to their fields, fell at the hands of settlers. Zeisberger, with such of his converts as remained faithful, sought refuge in Michigan, then at New Salem, Ohio, and in 1791 at Fairfield, in Canada. In 1798 they were allowed to repossess their old lands in the Tuscarawas valley. Here, at Goshen, he spent his last years among a few forlorn and drunken Indians, to whom he preached industry and sobriety in vain. He died Nov. 19, 1808, leaving the memory of a devoted if defeated life, and some valuable contributions to philological lore. His *Delaware Spelling-book* (1776; and again 1806 and 1816), *Hymn-book* (1805; reprinted 1847), *Sermons to Children* (1813) and *Harmony of the Gospels* (1821), are all in the Delaware tongue. His *German and Onondaga Lexicon* (7 vols. 4to.), two *Onondaga Grammars*, a *Delaware Grammar and Dictionary*, and some vocabularies, are preserved in MS. in Philadelphia, or at Cambridge, Mass. His *Life and Times* was written by E. De Schweinitz (1870; 2d ed. 1886); his *Diary*, translated by E. F. Bliss, was published in 2 vols. 1885, by the Ohio Historical and Philosophical Society.

ZEPHANIAH. See PROPHEETS.

ZOECKLER, OTTO, German theologian, was born at Grünberg, Hesse, May 27, 1833. He was educated at Giessen, Erlangen, and Berlin Universities,

graduating in 1856. He began to teach at Giessen, and in 1863 was made professor extraordinary. In 1866 he became ordinary professor at Greifswald, and in the next year began to edit the *Allgemeine literarische Anzeiger* which he conducted for seven years. In 1882 he was made editor of the *Evangelische Kirchenzeitung*. Among his works are *Theologia Naturalis* (1860); *Kritische Geschichte der Askese* (1863); *Hieronymus* (1864); *Die Urgeschichte der Erde und des Menschen* (1868); *Das Kreuz Christi* (1875); *Geschichte der Beziehungen zwischen Theologie und Naturwissenschaft* (2 vols. 1877-79); *Die Lehre vom Urstand des Menschen* (1879); *Gottes Zeugen im Reich der Natur* (2 vols. 1881); *Hand-buch der theologischen Wissenschaften* (3 vols. 1833-84), in which he was assisted by others.

ZUNZ, LEOPOLD (1794-1886), Jewish author, was born at Detmold, Lippe, Germany, Aug. 10, 1794. He was a teacher for some years before he went to Berlin to study philology. There he became preacher to the Jewish congregation in 1820, editor of a newspaper in 1824, and principal of a Jewish school in 1825. In 1835 he was called to Prague as a preacher, but in 1839 returned to Berlin to take charge of a normal school. In 1845 he was appointed member of a government commission to devise measures for the educational improvement of the Jews in Prussia. In 1850 he resigned his position in the normal school, and was afterwards chiefly engaged in literary labor. His researches shed much light on Hebrew literature. He died at Berlin March 17, 1886. As early as 1818 he had published *Etwas über die rabbinische Literatur*, but his chief works were *Die gottesdienstlichen Vorträge der Juden* (1832); *Die synagogale Poesie des Mittelalters* (1855); *Die Ritus des synagogalen Gottesdienstes geschichtlich entwickelt* (1859); and *Litteraturgeschichte der synagogalen Poesie* (1865). His collected works appeared in three volumes (1875-76). He was also engaged with other Jewish scholars on a German translation of the Bible.

58

Encyclopaedia Britannica.

S.D
E568.2

American supplement to Encyclopaedia
Britannica. Ed.9. Vol.4

NAME OF BORROWER.

**University of Toronto
Library**

**DO NOT
REMOVE
THE
CARD
FROM
THIS
POCKET**

Acme Library Card Pocket
LOWE-MARTIN CO. LIMITED

